

NATIONAL ADVISORY COMMITTEE FOR AERONAUTICS

WARTIME REPORT

ORIGINALLY ISSUED

June 1943 as
Advance ~~Restricted~~ Report 3F07

FLIGHT TESTS OF VARIOUS TAIL MODIFICATIONS

ON THE BREWSTER XSBA-1 AIRPLANE

I - MEASUREMENTS OF FLYING QUALITIES

WITH ORIGINAL TAIL SURFACES

By W. H. Phillips and J. M. Nissen

Langley Memorial Aeronautical Laboratory
Langley Field, Va.



WASHINGTON

NACA WARTIME REPORTS are reprints of papers originally issued to provide rapid distribution of advance research results to an authorized group requiring them for the war effort. They were previously held under a security status but are now unclassified. Some of these reports were not technically edited. All have been reproduced without change in order to expedite general distribution.

L-412

NATIONAL ADVISORY COMMITTEE FOR AERONAUTICS

ADVANCE ██████████ REPORT

FLIGHT TESTS OF VARIOUS TAIL MODIFICATIONS
ON THE BREWSTER XSBA-1 AIRPLANE
I - MEASUREMENTS OF FLYING
QUALITIES WITH ORIGINAL
TAIL SURFACES¹

By W. H. Phillips and J. M. Nissen

SUMMARY

A series of tests of the Brewster XSBA-1 airplane is being conducted to determine the effect of various tail modifications. The present report describes an investigation of flying qualities of the airplane with its original tail surfaces. The results may be summarized as follows:

1. The static longitudinal stability with stick fixed or free was positive in all conditions tested.
2. The average elevator force required in highly accelerated maneuvers was 30 pounds per g normal acceleration. This value was considered undesirably large.
3. The stick travel required to stall in maneuvers was about 4.6 inches.
4. Trim changes caused by depressing the flaps or by application of power were in the direction causing the nose to rise. The stick forces to maintain trim were considered excessive.
5. Lateral oscillations of the airplane with controls free damped to $\frac{1}{2}$ amplitude in less than 2 cycles. No undamped short-period oscillations of the controls themselves existed.
6. The aileron effectiveness was sufficient to give a value of the helix angle $\text{pb}/2V$ of 0.075 radian in right

¹The tail surfaces referred to in this report as "original tail surfaces" were different from those used on earlier models of the XSBA-1 airplane. This tail design was developed by the Naval Aircraft Factory as a prototype for the tail surfaces later used in production models of the SBN-1 airplane.

rolls, 0.085 radian in left rolls. Aileron control forces were considered excessive.

7. The directional stability and dihedral effect were satisfactory. The pitching moment due to sideslip was desirably small.

8. The rudder control was sufficiently effective for all flight conditions, but the rudder forces were considered excessive.

9. The stalling characteristics were satisfactory.

INTRODUCTION

At the request of the Bureau of Aeronautics, Navy Department, a series of tests of the Brewster XSBA-1 airplane is being conducted to determine the effects of various tail modifications. The modifications are to include (1) variation of the chord of the elevators and rudder while the total area of the surfaces is kept constant and (2) variations of the total area of the vertical tail surface. This report presents the results of tests to determine the flying qualities of the airplane with its original tail surfaces. The tests were conducted at the Langley Memorial Aeronautical Laboratory.

DESCRIPTION OF BREWSTER XSBA-1 AIRPLANE

The XSBA-1 airplane is a two-place, single-engine, mid-wing, cantilever monoplane with retractable landing gear. For the investigations described in this report, the cut-outs in the flap were sealed to give a conventional partial-span split flap. (See figs. 1 to 4.) The general specifications of the airplane follow:

| | |
|---|---|
| Name and type | Brewster XSBA-1 |
| Engine | Wright Cyclone R-1820-38 |
| Rated: | |
| Take-off | 950 hp at 2200 rpm and 41.0 in. Hg manifold pressure |
| Maximum continuous (sea level) | 850 hp at 2100 rpm and 35.7 in. Hg manifold pressure |
| Cruising | 600 hp at 1900 rpm and 30 in. Hg manifold pressure |

L-412

Gear ratio (ungeared) 1:1
 Propeller Hamilton Standard constant speed
 Diameter 9 ft
 Number of blades 3
 Fuel capacity 136 gal
 Oil capacity 10 gal
 Empty weight 3620 lb
 Normal gross weight (Scout) 5276 lb
 Wing loading (normal gross weight) 20.4 lb/sq ft
 Power loading (normal gross weight) 6.6 lb/hp
 Over-all height (thrust-axis level) 12 ft, 2 $\frac{3}{4}$ in.
 Over-all height (three-point
 position to propeller tips) 9 ft, 3 $\frac{1}{4}$ in.
 Over-all length 27 ft, 11 $\frac{1}{8}$ in.
 Wing:
 Span 39 ft, 0 in.
 Area (including ailerons
 and 29 $\frac{1}{2}$ sq ft fuselage) 258 sq ft
 Airfoil section NACA CYH tapered 18 percent to
 11.8 percent thick
 Aspect ratio 5.9
 Mean aerodynamic chord 83.3 in.
 Distance behind leading edge of
 wing at root 2.39 in.
 Taper ratio 1.5:1
 Dihedral:
 Leading edge of center section 1.7 $^{\circ}$
 Leading edge of outer panel 4.5 $^{\circ}$
 Incidence 0 $^{\circ}$
 Sweepback (L.E. of wing) 1.6 $^{\circ}$
 Wing flaps:
 Area 20.4 sq ft
 Maximum deflection 67 $^{\circ}$
 Ailerons:
 Length 7 ft, 2 in.
 Area, behind hinge line (each) 9.7 sq ft
 Trimming-tab area,
 behind hinge line (each) 0.63 sq ft
 Fin area (above fuselage, ahead of
 hinge line, not including balance area) 12.1 sq ft
 Rudder:
 Vertical span (from center line
 of fuselage) 6 ft, 6 $\frac{3}{4}$ in.
 Area (behind hinge line but
 including horn-balance area) 13.9 sq ft
 Horn-balance area 1.5 sq ft
 Trimming-tab area None

| | |
|--|-----------------------------------|
| Stabilizer area (ahead of hinge line, not including horn-balance area but including contained fuselage area) | 30.6 sq ft |
| Elevator: | |
| Span | 14 ft, 10 in. |
| Area (behind hinge line including horn-balance area) | 30.6 sq ft |
| Trimming-tab area | 1.7 sq ft |
| Trimming-tab travel | 9.0° tail heavy, 15.5° nose heavy |
| Distance from elevator and rudder hinge lines to leading edge of wing | 18 ft, 11 $\frac{1}{2}$ in. |
| Maximum fuselage cross-sectional area (at cowling) | 18.3 sq ft |

The original horizontal and vertical tail surfaces are shown in figures 5 and 6.

The relation between the control-stick position and the elevator and aileron angles is shown in figures 7 and 8.

INSTRUMENT INSTALLATION

| Item | NACA instrument |
|---|------------------------------------|
| Time | Timer |
| Airspeed | Airspeed recorder |
| Elevator, aileron, and rudder control forces | Control-force recorders |
| Angular velocity about the three airplane axes | Angular-velocity recorders |
| Normal, longitudinal, and lateral acceleration | Three-component accelero- meter |
| Angle of sideslip | Recording yaw vane |
| Inclination of thrust axis or angle of bank | Recording inclinometer |

The airspeed recorder was connected to a pitot-static head attached to a boom extending 1 chord length ahead of the right wing tip. This instrument was free to swivel in pitch but not in yaw. The yaw vane was connected to a similar boom on the left wing tip. For measurements of rudder and elevator angles in cases in which the control forces were large, control-position recorders attached

L-412

directly to the elevator and rudder were used. Errors due to cable stretch were thereby eliminated. In addition, the rudder, elevator, and aileron angles were measured by a three-component control-position recorder attached to the control cables near the rear cockpit. In cases in which the recorders attached directly to the rudder and elevator were not used, the angles recorded by this instrument were corrected for stretch in the control cables. No attempt was made, however, to correct the recorded aileron angles for stretch in the aileron linkage.

AIRSPPEED CALIBRATION

The calibration of the airspeed recorder was made by the use of a trailing airspeed head.

TESTS, RESULTS, AND DISCUSSION

All the measurements of flying qualities were made with the center of gravity located at 25.5 percent of the mean aerodynamic chord with full service load. In this condition, the airplane weighed 5770 pounds. Retracting the landing gear had no effect on the horizontal location of the center of gravity. When all the gas and oil were used, the center of gravity was moved forward to 23.8 percent of the mean aerodynamic chord. The vertical location of the center of gravity was at 3.0 percent of the mean aerodynamic chord above the thrust axis with landing gear retracted, or at 1.2 percent of the mean aerodynamic chord above the thrust axis with landing gear extended.

Longitudinal Stability and Control

Characteristics of uncontrolled longitudinal motion. - Of the two types of control-free longitudinal oscillation, only the short-period oscillation was investigated with the XSBA-1 airplane because previous research has shown that the well-known long-period (phugoid) oscillation has little or no correlation with the ability of pilots to fly an airplane efficiently.

The degree of damping of the short-period oscillation was determined by deflecting the elevator and quickly

releasing it at high speed. In all cases, the subsequent variation of normal acceleration and elevator angle had completely disappeared after one cycle, thereby satisfying the requirement for this condition suggested in reference 1.

Characteristics of elevator control in steady flight. - The characteristics of the elevator control of the XSBA-1 airplane in steady flight were measured by recording the elevator positions and forces required for trim at various airspeeds and trimming-tab settings. The measurements were made in the following conditions of flight:

| Flight condition | Manifold pressure at 6000 ft (in. Hg) | Engine speed (rpm) | Flap position | Landing-gear position |
|------------------|---------------------------------------|--------------------|---------------|-----------------------|
| Cruising | 25 | 1800 | Up | Up |
| Climbing | 32 | 1800 | ---do--- | Do. |
| Gliding | Throttle closed | ---- | ---do--- | Do. |
| Landing | -----do----- | ---- | Down | Down |
| Approach | 18 | 1900 | Half down | Do. |
| Wave-off | 34 | 2100 | Down | Do. |

Conclusions reached regarding the elevator control characteristics may be summarized as follows:

(1) In all the flight conditions tested, stick-fixed static stability existed, as shown by the negative slopes of the curves of elevator angle against airspeed (figs. 9 to 12). The stability was greatest in the landing condition (flaps and landing gear down, power off). It was also relatively large in the gliding condition (flaps and landing gear up, power off). The large increase in up elevator angle at low speeds in the gliding condition was believed to be caused by separation of the flow at the wing root as the stall was approached. The static stability possessed by this airplane in the flaps-down, power-on conditions of flight was unusually large, inasmuch as static instability is often encountered in these conditions.

(2) The slope of the stick-force curves is negative at the speeds at which the airplane is trimmed in all conditions of flight. This characteristic assures stick-free static stability of the airplane in all flight conditions. The variations of stick force with airspeed in the flaps-up conditions have a characteristic shape that is believed to be

caused by nonlinear hinge-moment properties of the elevator and by the influence of the wing wake at the tail.

(3) The gradient of elevator control force was sufficiently large and the friction sufficiently small in all conditions to return the control to its trim position.

(4) The elevator angles required for trim were well within the available range in all conditions.

Characteristics of the elevator control in accelerated flight. - The characteristics of the elevator control in accelerated flight were determined from measurements taken in abrupt pull-ups and push-downs from level flight and in rapid 180° turns. The results of the pull-ups and push-downs are presented in figure 13. Time histories of representative turns are presented in figures 14 to 17. The results of the tests pertaining to the elevator control may be summarized as follows:

(1) The elevator control was sufficiently powerful to develop either the maximum lift coefficient or the allowable load factor at every speed. This fact was evident in pull-ups made at various speeds.

(2) The normal acceleration was observed to increase progressively with the elevator angle at any given speed.

(3) Figure 15 shows a time history of a turn in which the stick was pulled back until a stall occurred; an elevator deflection of 12° from the trim position was required to reach the maximum lift coefficient. This deflection corresponds to a stick movement of 4.6 inches, which satisfies the requirements of reference 1.

(4) The variation of stick force with normal acceleration in 180° turns is plotted in figure 18. A large increase in stick force and elevator angle occurred as the stall was approached. For this reason, turns made at lift coefficients near the stall required a greater force per g acceleration than turns made at low lift coefficients.

(5) On the basis of the force required to make a $4g$ turn, it is seen that about 30 pounds per g was required to make highly accelerated turns. This value is considered excessive. For scout-bomber airplanes, such as the XSBA-1, a value of 15 pounds per g seems reasonable as an acceptable upper limit of stick forces.

Characteristics of the elevator control in landing. -

The elevator control was sufficiently powerful to hold the airplane off the ground until three-point contact was made. The average of records taken of several landings shows that 21° up elevator deflection was required to make a three-point landing. In the cases of several low-wing airplanes that have been tested, about 10° more up elevator deflection was required to land than to reach the stall in the landing condition at altitude. In the case of the XSBA-1 airplane, however, the up elevator deflection required to land was about the same as that needed to stall. The reason for this condition is believed to be that separation of the flow from the wing root reduced the downwash at the tail as the stall was approached, just as the ground effect reduces the downwash at the tail when the airplane is landing. The elevator control force required to make a three-point landing was about 41 pounds. This force is considered excessive and is larger than the upper limit of 35 pounds recommended in reference 1.

Characteristics of the elevator control in take-off. -

The elevator was adequate to raise the tail or to adjust the attitude angle as desired during take-off. Figure 19 shows a time history of a take-off in which the tail was raised fairly early in the run.

Trim changes due to power and flaps. - The trim change caused by lowering the flaps was in the direction tending to cause the airplane to nose up. Lowering the landing gear caused the airplane to nose down. A push force of about 16 pounds was required to maintain trim if the flaps and the landing gear were lowered with power on at 120 miles per hour. This trim change is in the opposite direction to that usually considered desirable. Application of power with flaps and landing gear up had a slight tendency to nose the airplane up. With flaps and landing gear down, this tendency was increased. A push force of about 18 pounds was required to maintain trim at 120 miles per hour if full power was applied when flaps and landing gear were down. The stick-force change at 120 miles per hour in going from the flaps-up, power-off condition to the flaps-down, full-power condition was about 38 pounds, which exceeds the upper limit of 35 pounds recommended in reference 1.

Characteristics of the longitudinal trimming device. -

The stick force per degree trimming-tab change as a function of indicated airspeed in various flight conditions is shown in figure 20. The trimming-tab setting required to trim at zero stick force in these conditions is plotted in figures 9 to 11. The trimming tabs were sufficiently powerful to

reduce the stick force to zero at any point in the speed range in the power-on flight condition. In the power-off conditions, the airplane could be trimmed at all speeds in the speed range greater than 10 miles per hour above the stall. Unless changed manually, the trimming device retained a given setting indefinitely.

Characteristics of uncontrolled lateral and directional motion. - The lateral motion of the Brewster XSBA-1 airplane with controls free following a disturbance was measured in the cruising, gliding, and landing flight conditions at various speeds. The period and damping of these lateral oscillations as functions of airspeed are shown in figure 21. The conclusions reached with regard to the uncontrolled lateral and directional motion are as follows:

- (1) In all cases, the lateral oscillations were well damped and met the requirements of reference 1.
- (2) When the ailerons were deflected and released quickly, they returned to their trim position. No oscillation of the ailerons themselves was noted.
- (3) When the rudder was deflected and released quickly, it returned to its trim position. No oscillation of the rudder itself was noted.

Aileron control characteristics. - The effectiveness of the ailerons of the Brewster XSBA-1 airplane was determined by recording the rolling and yawing velocities produced by abruptly deflecting the ailerons at various speeds while the rudder was held fixed. The rolling acceleration was obtained by differentiating the angular-velocity record. The aileron angles and forces and the angle of sideslip were also measured.

The results of the aileron tests are presented in figures 22 to 24. Figures 22 and 23 show the variation of the maximum values of sideslip angle, aileron force, rolling velocity, and rolling acceleration reached in aileron rolls with various aileron deflections in the cruising and landing conditions at low speeds. The quantities are plotted against total aileron deflection, which is the sum of the deflections of the right and left ailerons from their trim positions.

The results may be summarized as follows:

- (1) The rolling velocity varied linearly with total aileron deflection. At a given speed, the rolling velocity was practically unaffected by flap or power condition.

(2) The variation of rolling acceleration with time following an abrupt control deflection was always in the correct direction and reached a maximum value in less than 0.2 second after the controls reached their given deflection.

(3) The XSBA-1 ailerons gave a maximum value of helix angle $\text{pb}/2V$ of 0.075 in right rolls and 0.085 in left rolls. This value was practically constant over the entire speed range.

(4) The variation of aileron force with deflection was approximately linear for about three-quarters of the maximum aileron deflection. From this point, the force increased rapidly to much larger values. This rapid increase of force was probably caused by separation of the flow from the lower surface of the aileron deflected upward. The balancing action of the projection on the Frise aileron was thereby reduced. The increase of force with deflection was so rapid that the force required to reach full deflection varied greatly with the setting of the stop in the aileron linkage. Evidence of the separation of flow from the lower surface of the aileron deflected upward is found in the curves of maximum sideslip angle against aileron deflection. The sideslip angle increases up to the point where the separation sets in. At higher deflections, it is reduced by the favorable yawing moment caused by the drag on the aileron deflected upward.

Because of the flexibility of the aileron linkage, the total aileron angle reached was probably less than that recorded in the rear cockpit. The flexibility of the system, combined with the flow separation on the aileron deflected upward, caused a violent shaking of the up aileron when it was fully deflected at speeds above 120 miles per hour.

The aileron forces for maximum deflection were considered excessive. From figure 24, it is seen that a force greater than 20 pounds was required to obtain full aileron deflection even at the minimum flying speed and that, at 175 miles per hour, which was about 80 percent of the maximum indicated speed, a force of about 42 pounds was required. This force exceeds the upper limit of 30 pounds at 80 percent of the maximum indicated speed given in reference 1.

Yaw due to ailerons. - With rudder locked at 110 percent of the minimum speed, the maximum change in sideslip developed as a result of full aileron deflection was about 20° , which is the maximum allowable sideslip angle recommended in reference 1.

Rolling moment due to sideslip. - The rolling moment due to sideslip was measured by recording the aileron angles required in steady sideslips. These measurements were made at various speeds in the climbing, gliding, and landing conditions. The results are presented in figures 25 to 30, in which the rudder, elevator, and aileron angles, the angle of bank, and the rudder force are plotted as functions of the sideslip angle. The sideslip angle plotted is simply that recorded by the yaw vane. The recorded angles of sideslip may have differed as much as 3° or 4° from the actual sideslip angles. This error would be simply a shift of the zero setting. The slopes of the curves of the plotted quantities may therefore be considered correct. The conclusions reached are as follows:

- (1) The dihedral effect was stable in all conditions tested as shown by the curves of aileron position against sideslip.
- (2) The aileron forces were not measured in sideslips; however, it was noted that the aileron always tended to return to a trim position when released.
- (3) The rolling moment due to sideslip was never so great that a reversal of rolling velocity occurred as a result of yaw due to ailerons.

Rudder control characteristics. - The rudder control characteristics were investigated in steady flight, in sideslips, in abrupt rudder kicks, and in rolls in which the rudder was used to maintain zero sideslip. In the rudder-kick maneuvers, records were taken of rudder position, of rolling, pitching, and yawing velocity, and of sideslip angle resulting from abrupt deflections of the rudder in steady flight while the other controls were held fixed. The results of the rudder kicks are shown in figures 31 to 33. The results of the sideslips are shown in figures 25 to 30. The variation of rudder angle required for trim in steady flight with indicated airspeed is shown in figure 34. Time histories of aileron rolls in which the rudder was used to hold zero sideslip are shown in figures 35 and 36.

The results may be summarized as follows:

- (1) The rudder control was sufficiently powerful to overcome the adverse aileron yawing moment in all conditions tested. This fact is shown by the time histories of aileron rolls (figs. 35 and 36), in which the rudder was used to

overcome the adverse yaw. In right rolls, nearly full rudder was required to overcome aileron yaw in the landing condition.

(2) The rudder was sufficiently powerful to maintain directional control during take-off and landing.

(3) Figure 34 shows that, for each condition tested, the rudder was sufficiently powerful to trim the airplane at all speeds greater than the minimum speed of the airplane.

(4) The effectiveness of the rudder in recovering from spins was not investigated.

(5) The rudder control force was proportional to the rudder deflection. Right rudder force was required to hold right rudder deflections and left rudder force was required to hold left rudder deflections.

(6) The curves of rudder force against angle of sideslip show that the rudder was uncomfortably heavy. The heavy rudder forces require considerable exertion on the part of the pilot in maneuvering and also have the disadvantage that they reduce the maximum rudder deflection that can be attained because of stretch in the rudder cables.

Yawing moment due to sideslip. - Characteristics of the yawing moment due to sideslip were found to be as follows:

(1) As has been previously stated, the directional stability was sufficient to restrict the yaw due to ailerons to the specified value.

(2) The yawing moment due to sideslip was such that the rudder always moved in the correct direction from the trim position; that is, right rudder produced left sideslip and left rudder produced right sideslip. For angles of sideslip between $\pm 15^\circ$, the angle of sideslip was substantially proportional to the rudder deflection.

(3) The yawing moment due to sideslip (rudder free) was such that the airplane always tended to return to the trim condition regardless of the angle of sideslip to which it was forced.

Cross-wind-force characteristics. - The variation of cross-wind force with sideslip angle, as measured in steady sideslips was everywhere such that right bank accompanied right sideslip and left bank accompanied left sideslip. The

angle of bank reached with maximum sideslip was comparatively small, especially at low speeds with power off.

Pitching moment due to sideslip. - The curves of elevator angle against angle of sideslip show that the pitching moment due to sideslip was very small. In sideslips to the left at 85 miles per hour in the gliding condition, about $1\frac{10}{2}$ ° of up elevator deflection was required to maintain longitudinal trim when the sideslip was produced by a right rudder deflection of 5°. In all other cases, the amount of elevator deflection required for a rudder deflection of 5° was less than 1°. It should be noted, in interpreting the curves of angle of sideslip for a given airspeed, that there may be some error in the indicated airspeed due to the angle of yaw of the pitot-static head.

Power of rudder and aileron trimming devices. - No trimming tab was provided on the rudder on the XSBA-1 airplane; however, the rudder is equipped with a trimming tab on the production models of this airplane.

The aileron trimming tab was sufficiently powerful to reduce the aileron forces to zero in all conditions of level flight. Unless changed manually, the trimming tab would retain a given setting indefinitely.

STALLING CHARACTERISTICS

The stalling characteristics of the Brewster XSBA-1 airplane were determined by recording the motion of the airplane and the control positions and forces during stalls made from various conditions of flight. In each condition, a stall was made with the controls held fixed in their trim positions. Stalls were then made in which control was attempted with the ailerons alone and with the rudder alone.

The results of these tests are presented in the form of time histories (figs. 37 to 48). The conclusions reached are as follows:

(1) In the gliding condition (flaps up, landing gear up, power off), the uncontrolled stall resulted in a rolling and pitching oscillation. The airplane did not tend to roll off. The stall apparently occurred at the wing root and spread gradually to the tips. This gradual stalling makes it difficult to assign a definite value to the stalling

speed. The amplitude of the oscillation could be reduced considerably by use of the ailerons alone, whereas control with the rudder alone only slightly reduced the amplitude.

(2) In the cruising condition (flaps up, landing gear up, cruising power), the stall was somewhat more violent. The airplane would roll off, usually to the left, if the stall was not controlled. The roll-off was preceded by rolling and pitching oscillations that served as a warning. It was found possible to prevent the roll-off by use of the ailerons but not by use of the rudder.

(3) The stall in the landing condition (flaps down, landing gear down, power off) resulted in a roll to the left that was preceded by some warning in the form of buffeting and pitching and rolling motions of the airplane. In no case was it possible to prevent the roll by use of the controls, though it could be delayed somewhat by means of the rudder.

(4) The stall in the take-off condition (flaps up, landing gear down, full throttle) resulted in a rather mild roll in either direction if the controls were held fixed. The airplane could be controlled beyond the stall by either the ailerons or the rudder, though the response to the controls was sluggish.

(5) No time histories were prepared of stalls in the approach condition (flaps half down, landing gear down, partial power). This stall, however, was extremely mild. If no attempt at control was made, the airplane would roll slowly from its level attitude. Good control could be maintained with either the ailerons or the rudder.

The following table gives the stalling speeds recorded in the various flight conditions:

| Condition | Manifold pressure at 6000 ft (in. Hg) | Engine speed (rpm) | Flap position | Landing-gear position | Indicated stalling speed (mph) |
|-----------|---------------------------------------|--------------------|---------------|-----------------------|--------------------------------|
| Gliding | Throttle closed | ----- | Up | Up | 80 |
| Cruising | 25 | 1800 | ---do--- | -----do----- | 66 |
| Climbing | 32 | 1800 | ---do--- | -----do----- | 68.5 |
| Take-off | 34 | 2100 | ---do--- | Down | 65 |
| Approach | 18 | 1900 | Half down | -----do----- | 58 |
| Landing | Throttle closed | ----- | Down | -----do----- | 70 |
| Wave-off | 34 | 2100 | ---do--- | -----do----- | 44 |

The stalling characteristics of the Brewster XSBA-1 airplane were considered to be unusually good. The stall was always preceded by adequate warning in the form of rolling and pitching motions of the airplane. Flight could be maintained beyond the stall in all except the landing condition.

CONCLUSIONS

The flying qualities of the Brewster XSBA-1 airplane with original tail surfaces were determined from flight measurements. The following conclusions apply for a center-of-gravity location at 25.5 percent of the mean aerodynamic chord:

1. The variation of elevator angle with airspeed indicated positive stick-fixed static longitudinal stability in all conditions tested.

2. The variation of elevator control force with airspeed indicated positive stick-free static longitudinal stability in all conditions tested.

3. The average elevator control force required in highly accelerated maneuvers amounted to 30 pounds per g normal acceleration. This value was considered undesirably large. It far exceeds the gradient of 15 pounds per g that seems reasonable as an upper limit for scout-bomber airplanes.

4. The stick travel required to stall in maneuvers was about 4.6 inches. This value was desirably large.

5. Trim changes caused by depressing the flaps were rather large and were in the direction causing the nose to rise. Application of power with flaps down likewise caused a nosing-up tendency. The stick-force change at 120 miles per hour in going from the flaps-up, power-off condition to the flaps-down, full-power condition was about 38 pounds, which exceeds the recommended upper limit of 35 pounds.

6. The motion of the airplane with controls free was normal. Lateral oscillations damped to $\frac{1}{2}$ amplitude in less than 2 cycles. No undamped short-period oscillations of the controls themselves existed.

7. The aileron effectiveness was sufficient to give a value of the helix angle $pb/2V$ of 0.075 radian in right rolls, 0.085 radian in left rolls. The aileron effectiveness was considered satisfactory.

8. The aileron forces were considered undesirably large. A stick force of about 42 pounds was required for full deflection of the aileron control stick at 175 miles per hour; this value exceeds the recommended limit of 30 pounds. A violent shaking of the aileron deflected upward occurred at full deflection of the controls.

9. The directional stability was sufficiently large to limit the yaw caused by full deflection of the ailerons with rudder fixed to about 20° at low flying speeds. The rolling moment due to sideslip was always positive. The pitching moment due to sideslip was desirably small in all flight conditions.

10. The rudder control was sufficiently effective to maintain straight flight at minimum speed in all flight conditions. It was also powerful enough to overcome aileron yaw in all conditions, though almost full deflection of the rudder was required for this purpose in right rolls at low speed in the landing condition (flaps down, power off). The forces required to deflect the rudder both in maneuvering and in counteracting trim changes were considered excessive.

11. The stalling characteristics were good. Adequate stall warning existed in all conditions of flight in the form of pitching and rolling motions of the airplane. Control of the airplane in a partly stalled condition could be

maintained in all except the landing condition. Recovery from the stall was prompt in all conditions.

Langley Memorial Aeronautical Laboratory,
National Advisory Committee for Aeronautics,
Langley Field, Va.

REFERENCE

1. Gilruth, R. R.: Requirements for Satisfactory Flying Qualities of Airplanes. NACA A.C.R., April 1941.

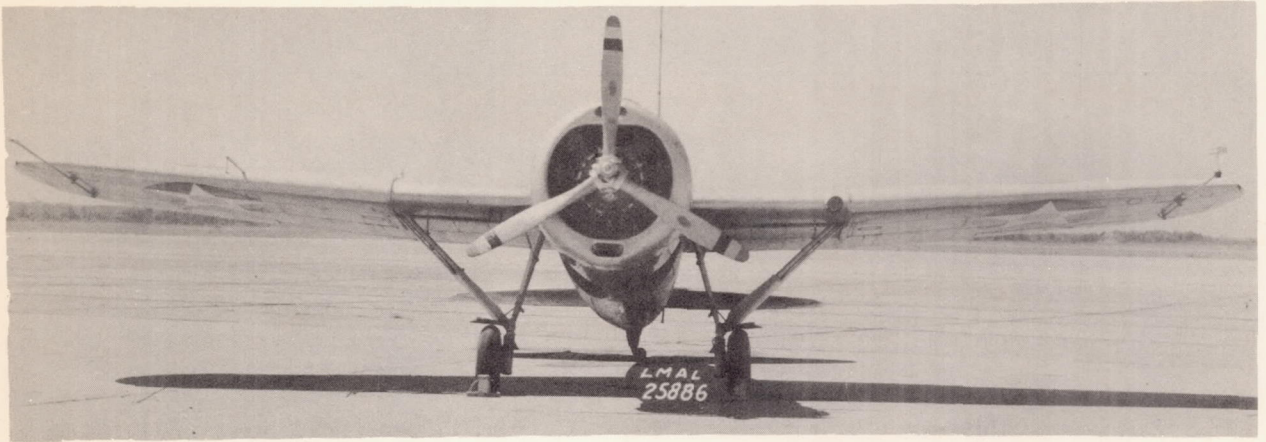

Figure 1.- Front view of Brewster XSBA-1 airplane.



Figure 2.- Three-quarter front view of Brewster XSBA-1 airplane.



Figure 3.- Side-view of Brewster XSBA-1 airplane.

L-412

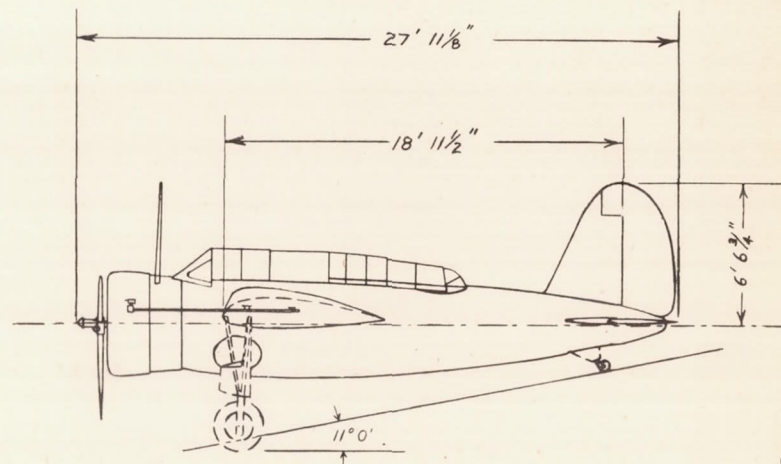
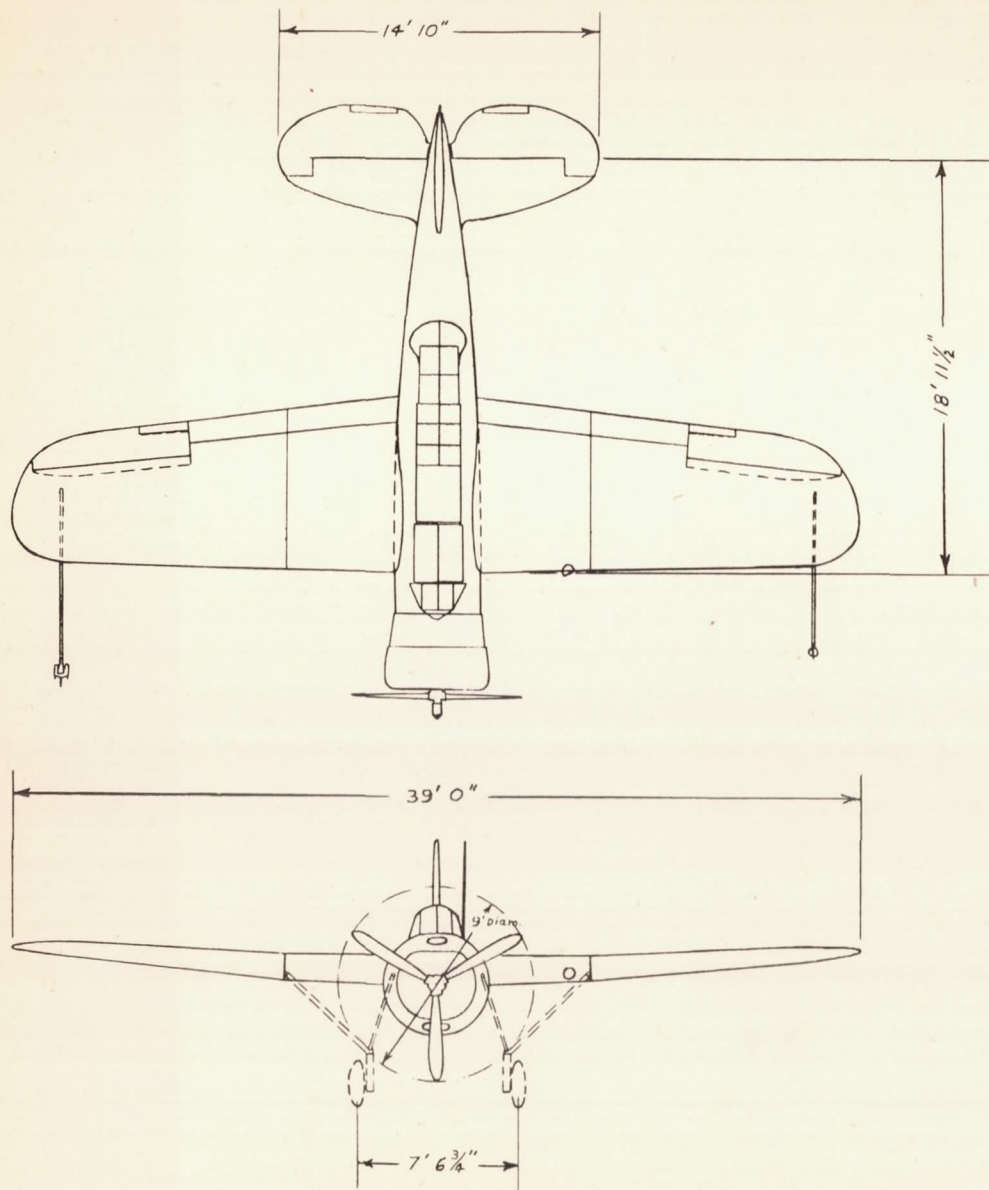

Figure 4. - Three-view drawing of the Brewster XSBA-1 airplane.

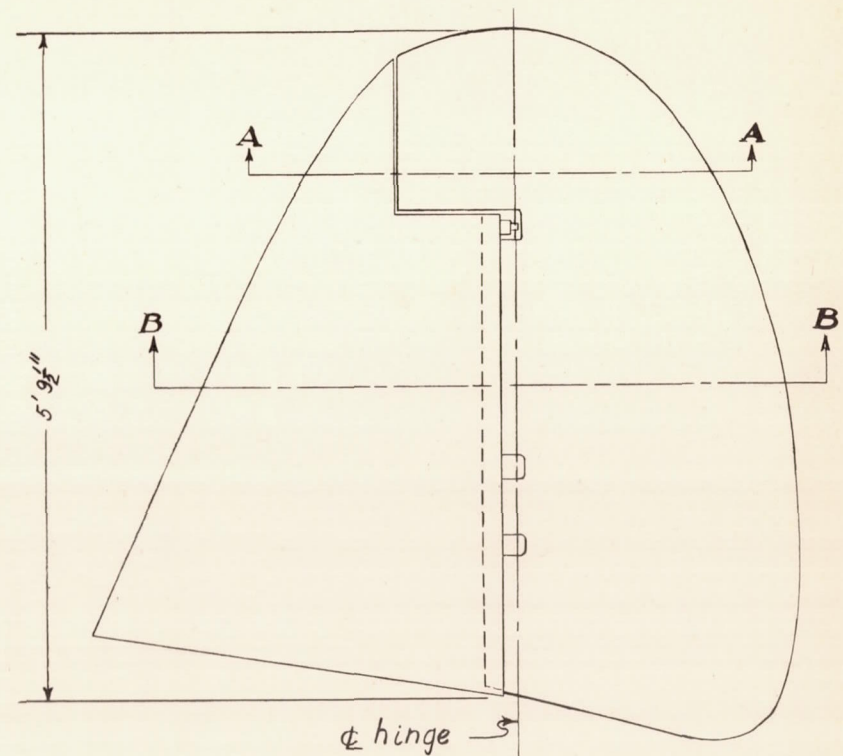
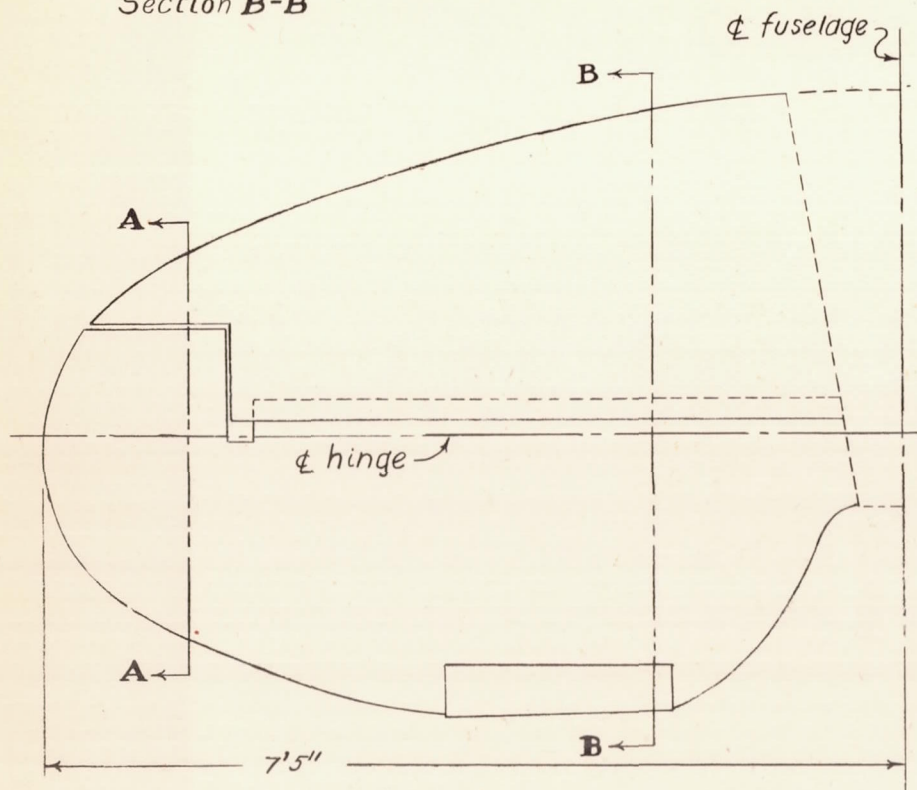
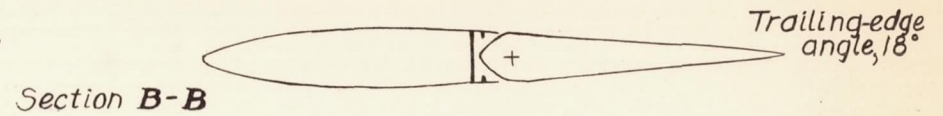
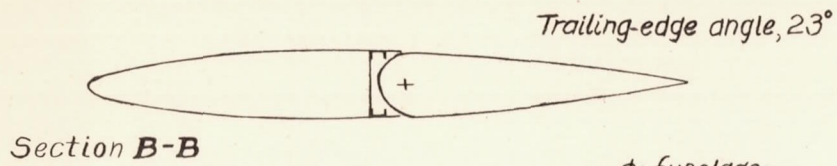
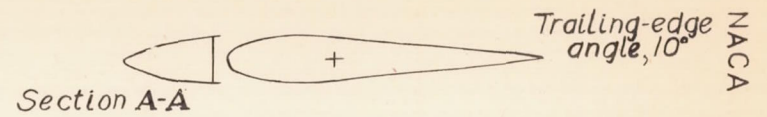
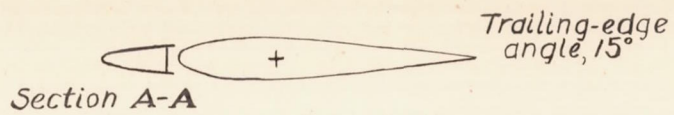

Figure 5. - Original horizontal tail surfaces of Brewster XSBA-1 airplane.

Figure 6. - Original vertical tail surface of the Brewster XSBA-1 airplane.

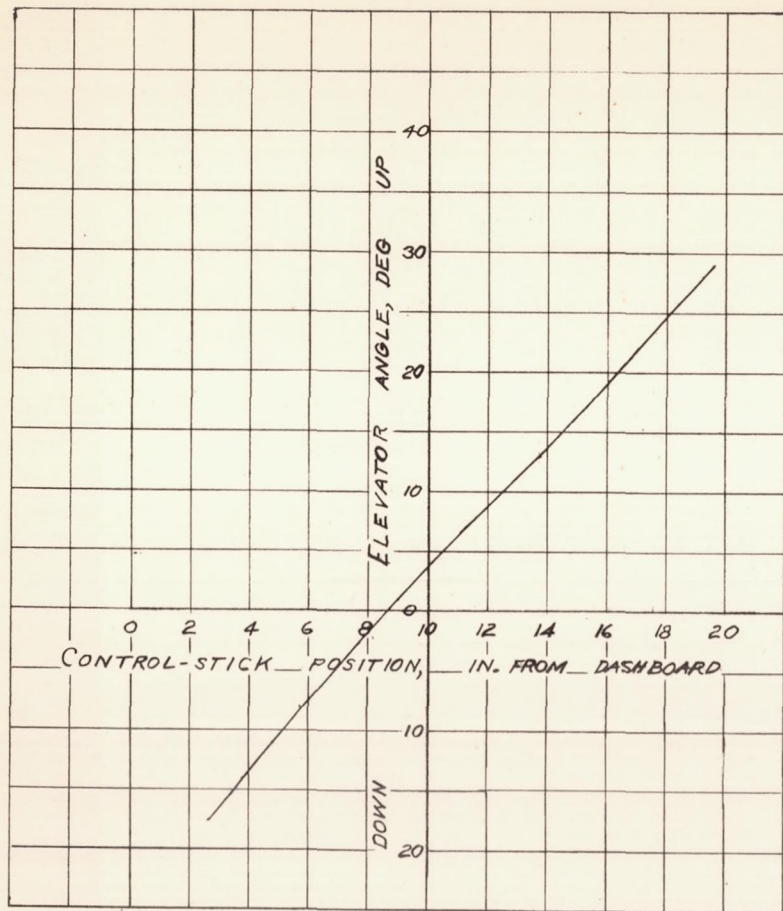

Figure 7. - Variation of elevator angle with position of the top of the control stick in front cockpit, Brewster XSBA-1 airplane.

(1 block = 10 divisions on 1/32" Arch. scale)

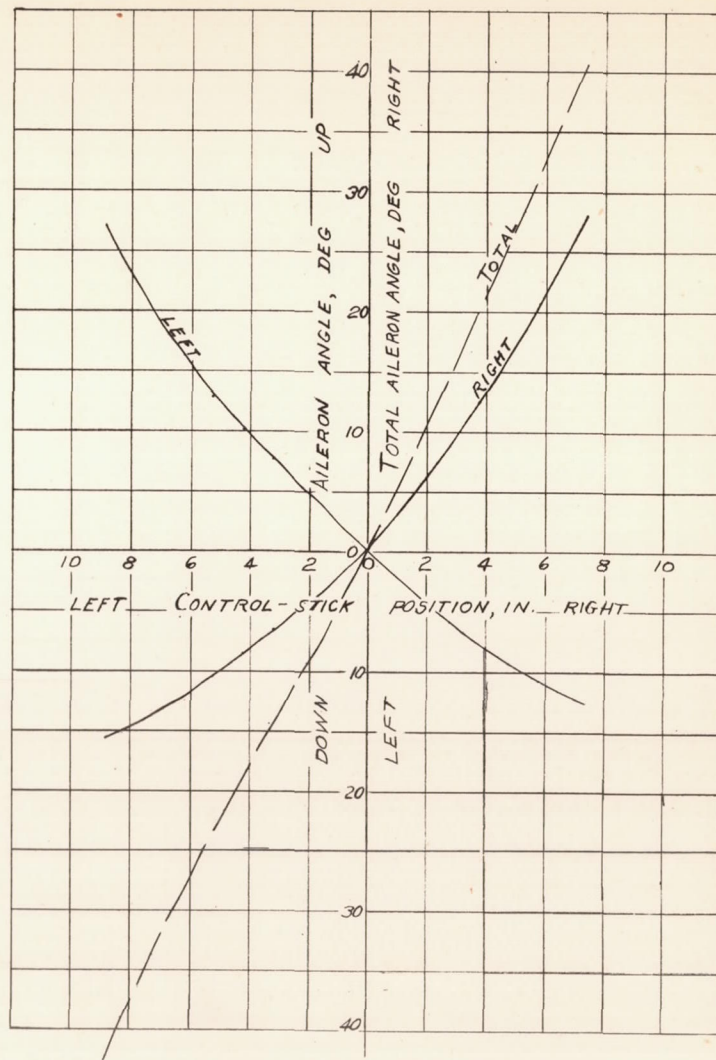

Figure 8. - Variation of angles of left and right ailerons and total aileron deflection with position of top of control stick. Brewster XSBA-1 airplane.

L-412

NACA

Fig. 9

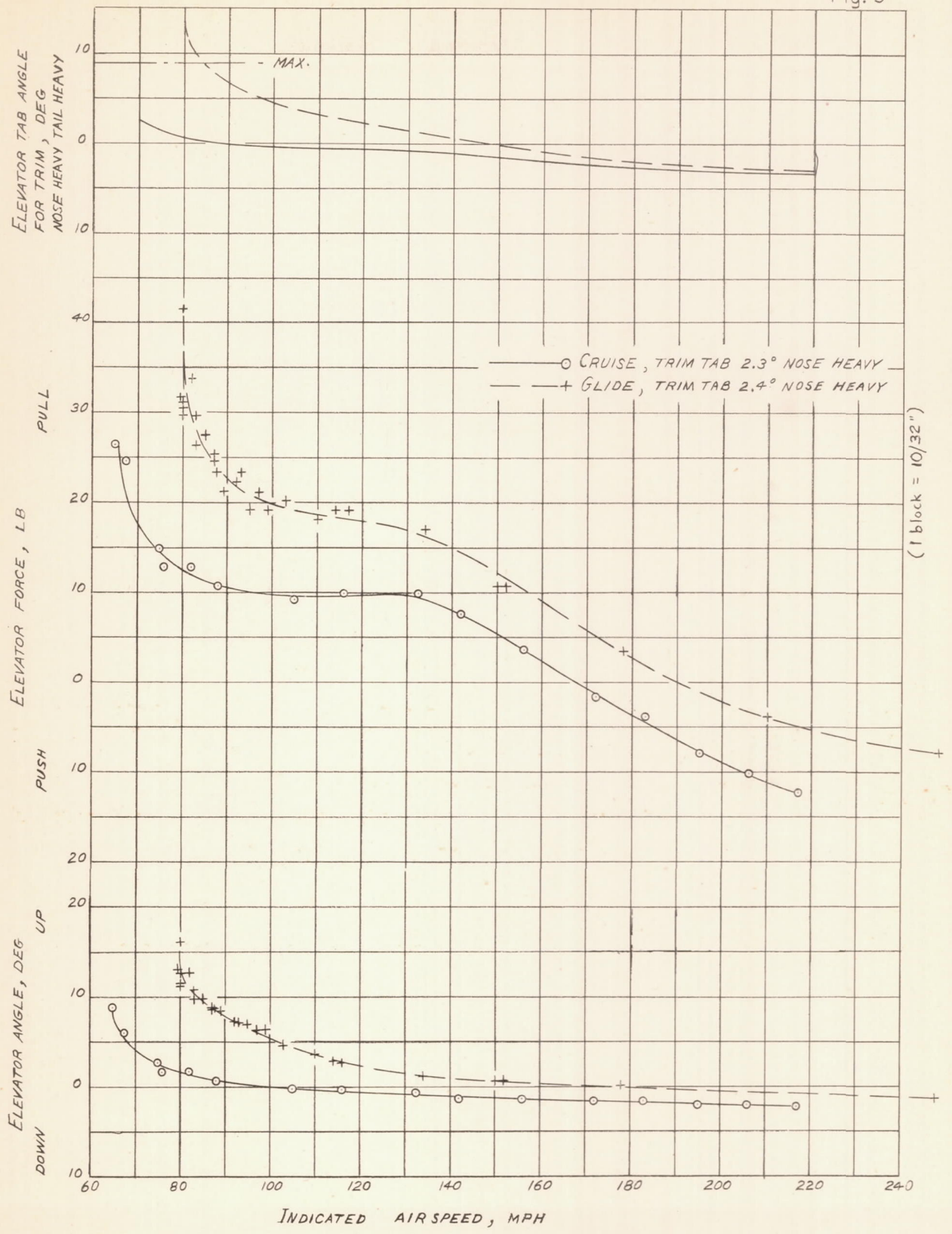

Figure 9. - Variation of elevator angle, elevator force, and elevator tab angle required for trim with indicated airspeed in the gliding and cruising conditions; Brewster XSBA-1 airplane.

1-4122

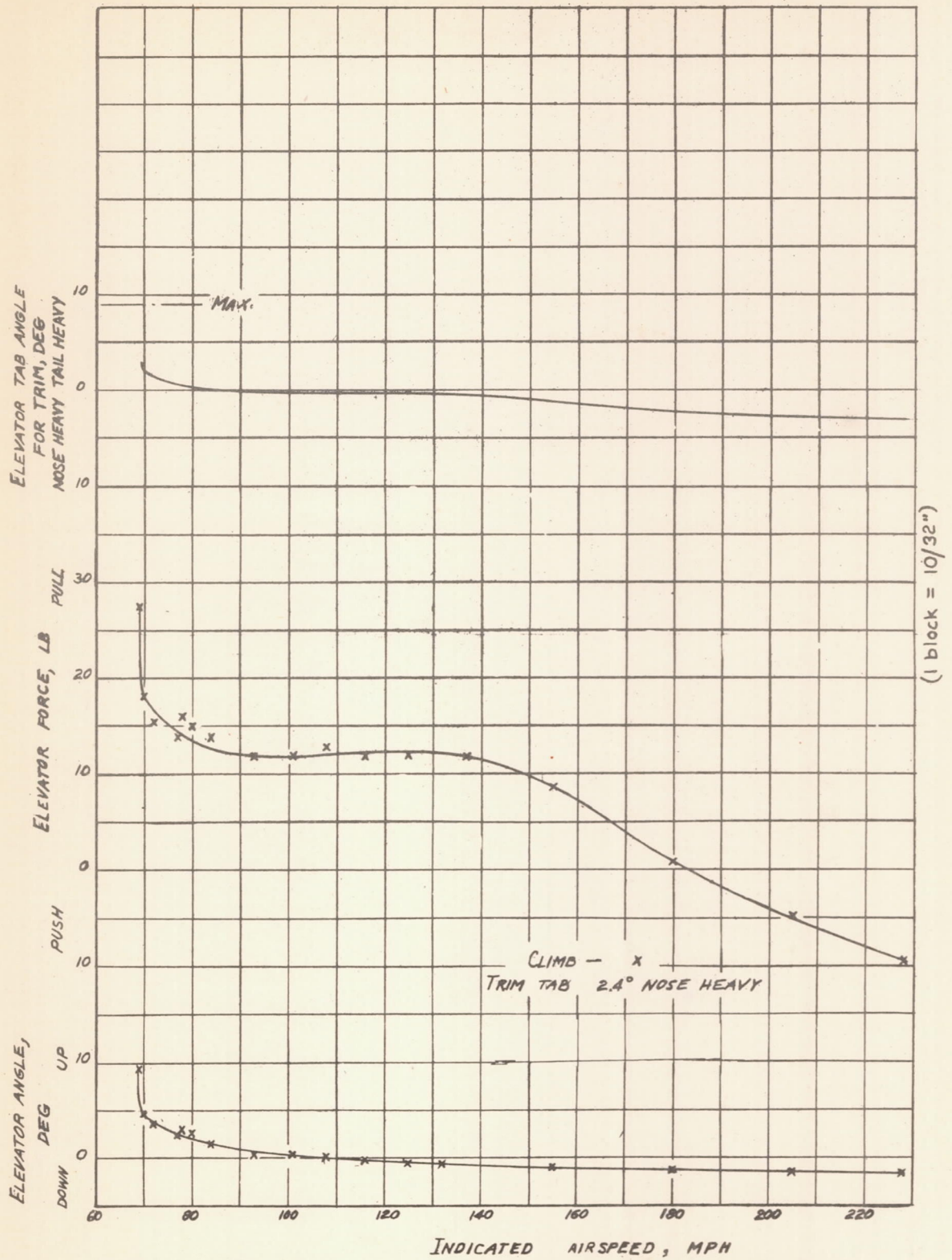

Figure 10. - Variation of elevator angle, elevator force, and elevator tab angle required for trim with indicated airspeed in the climbing condition; Brewster XSBA-1 airplane.

1-412

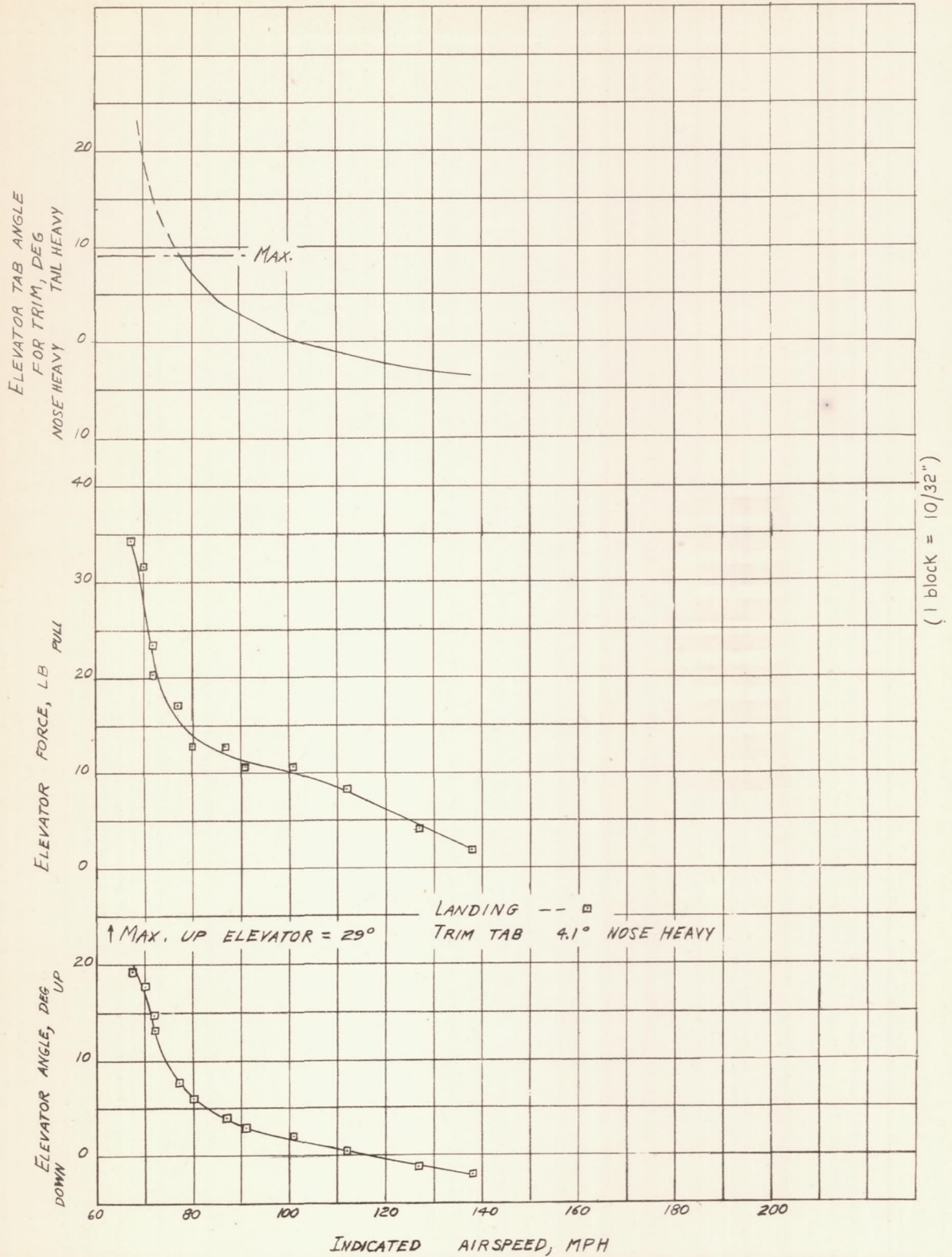

Figure 11. - Variation of elevator angle, elevator force, and elevator tab angle required for trim with indicated airspeed in the landing condition; Brewster XSBA-1 airplane.

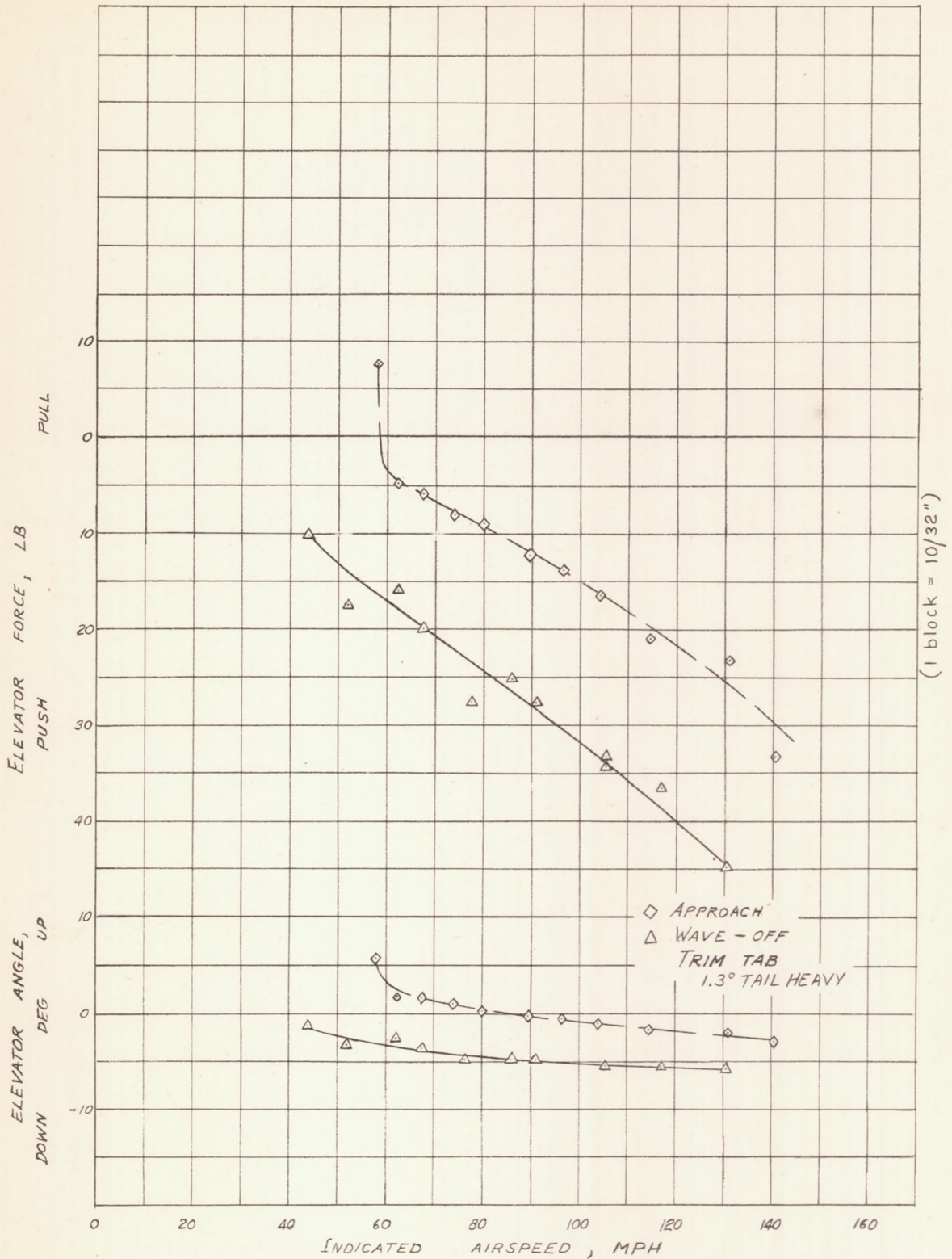

Figure 12. - Variation of elevator angle and elevator force with indicated airspeed in the approach and wave-off conditions; Brewster XSBA-1 airplane.

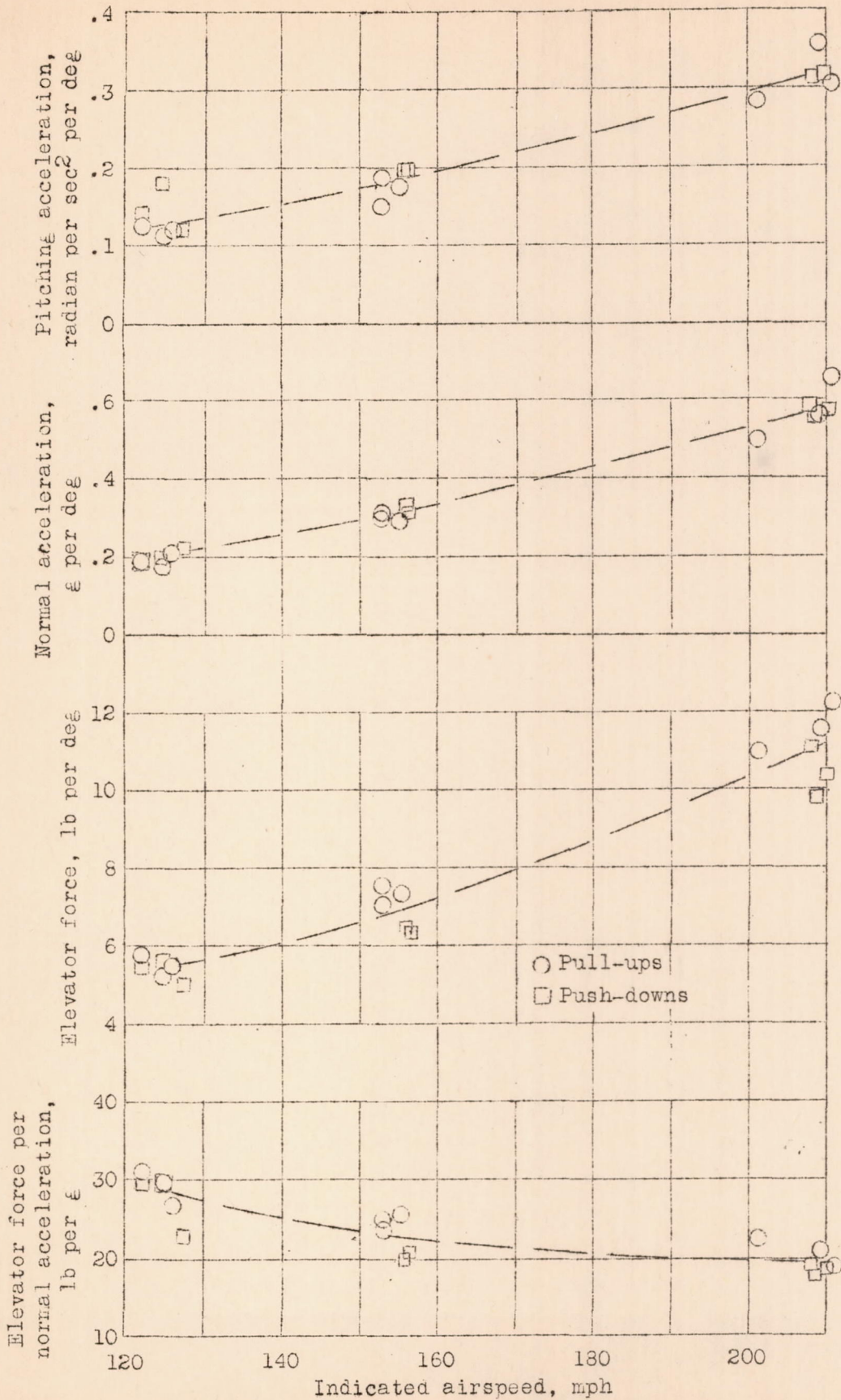

Figure 13.- Elevator control characteristics as measured in pull-ups and push-downs from level flight (flaps up, gear up). Brewster XSBA-1 airplane.

L-412

Fig. 14

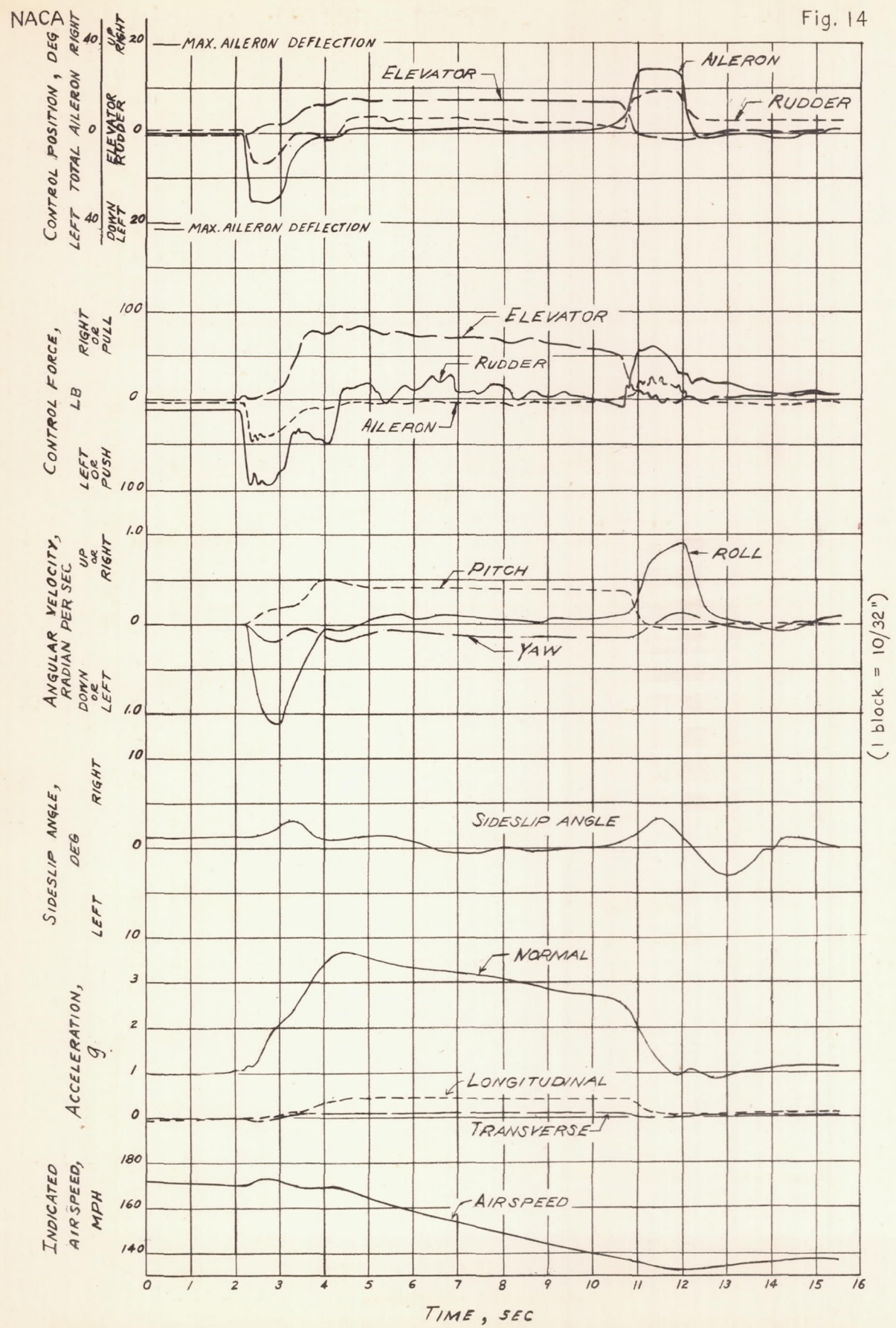

Figure 14. - Time history of a rapid 180° turn to the left started at 172 miles per hour. Note large elevator force. Brewster XSBA-1 airplane, flaps up, gear up, 18 inches Hg manifold pressure, 1800 rpm.

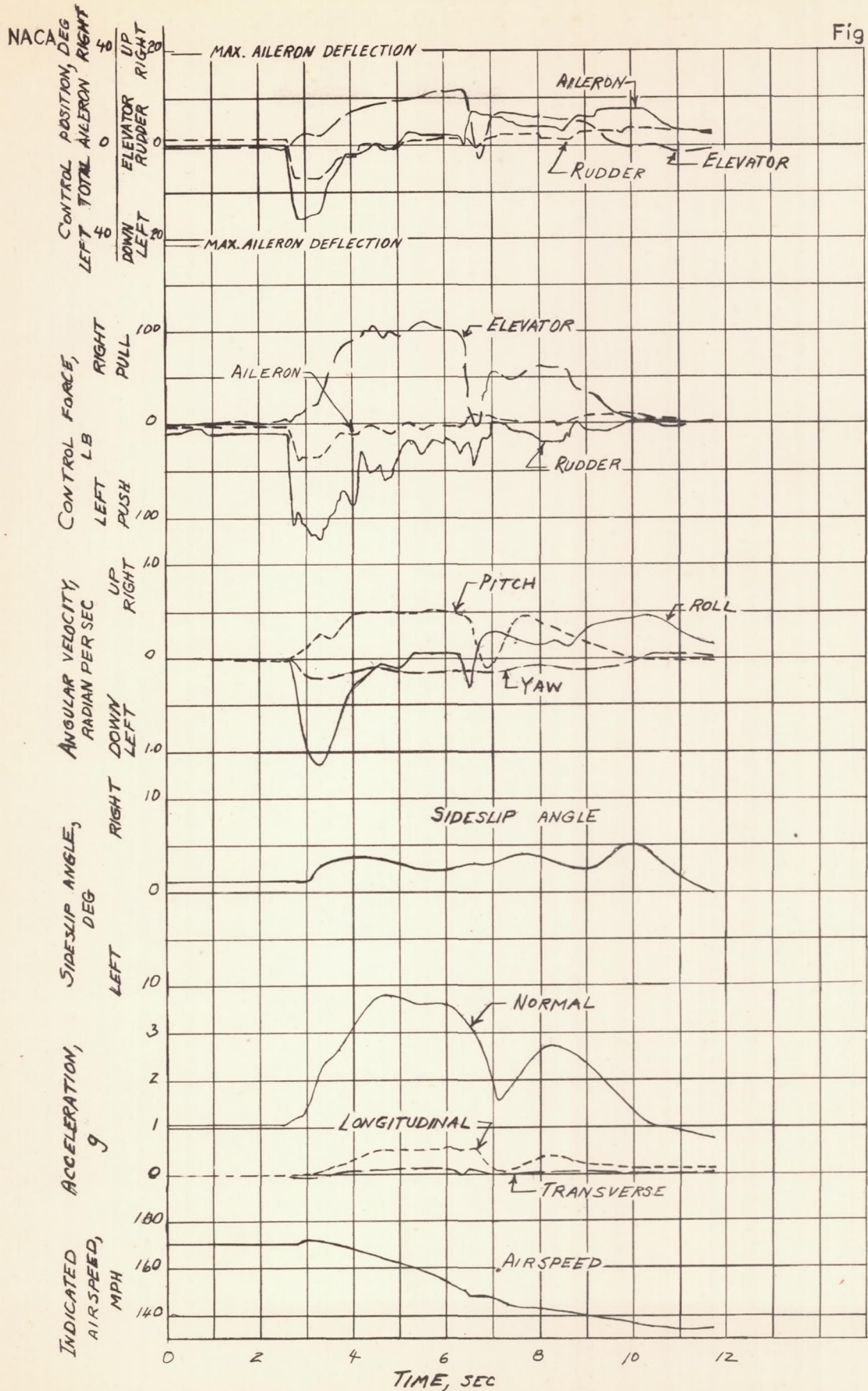

Figure 15. - Time history of a rapid turn to the left started at 171 miles per hour, in which a stall occurred. Brewster XSBA-1 airplane; flaps up, gear up, 18 inches Hg manifold pressure, 1800 rpm.

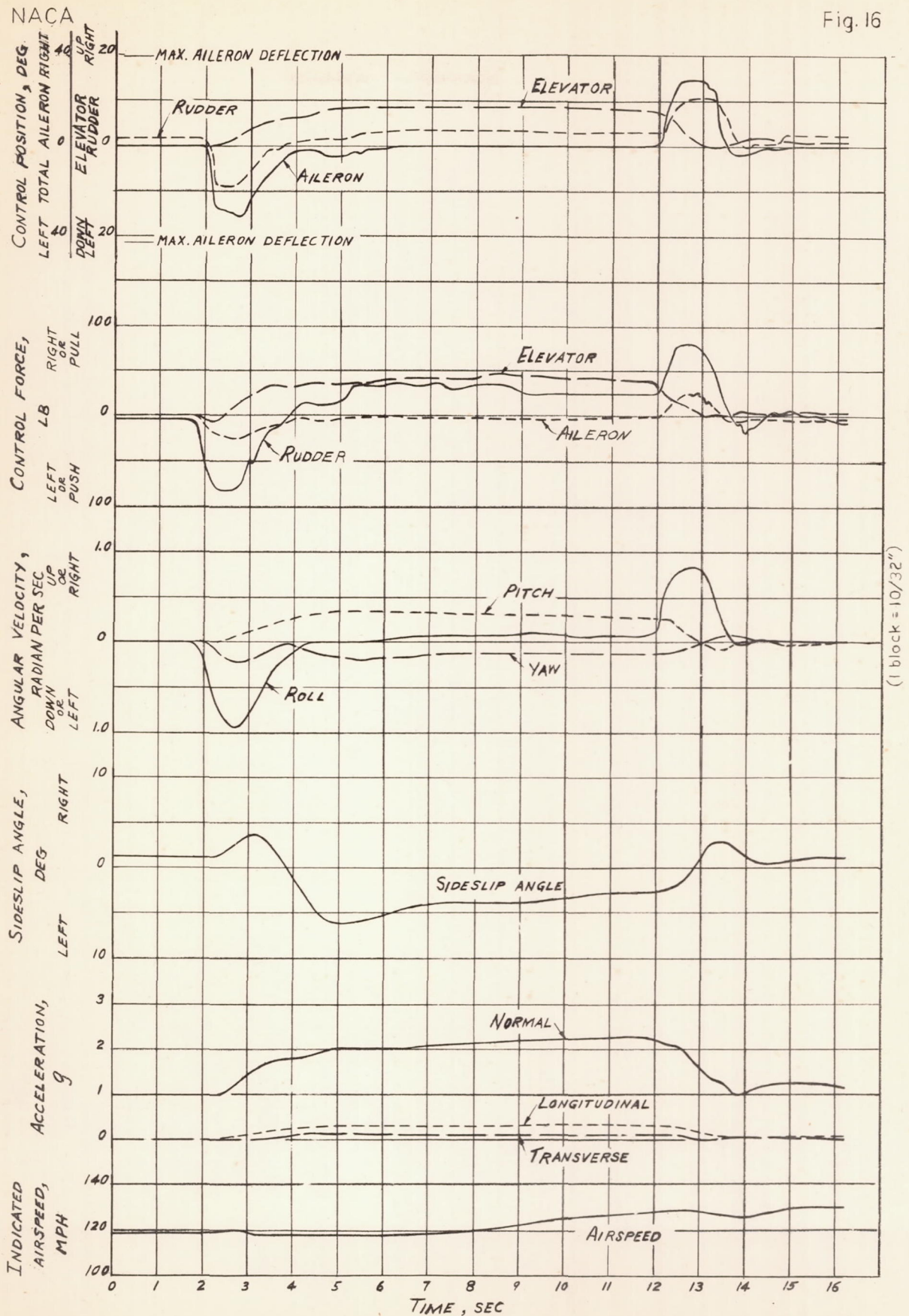

Figure 16. - Time history of a rapid 180° turn to the left started at 119 miles per hour. Brewster XSBA-1 airplane; flaps up, gear up, 18 inches Hg manifold pressure, 1800 rpm.

U-416

Fig. 17

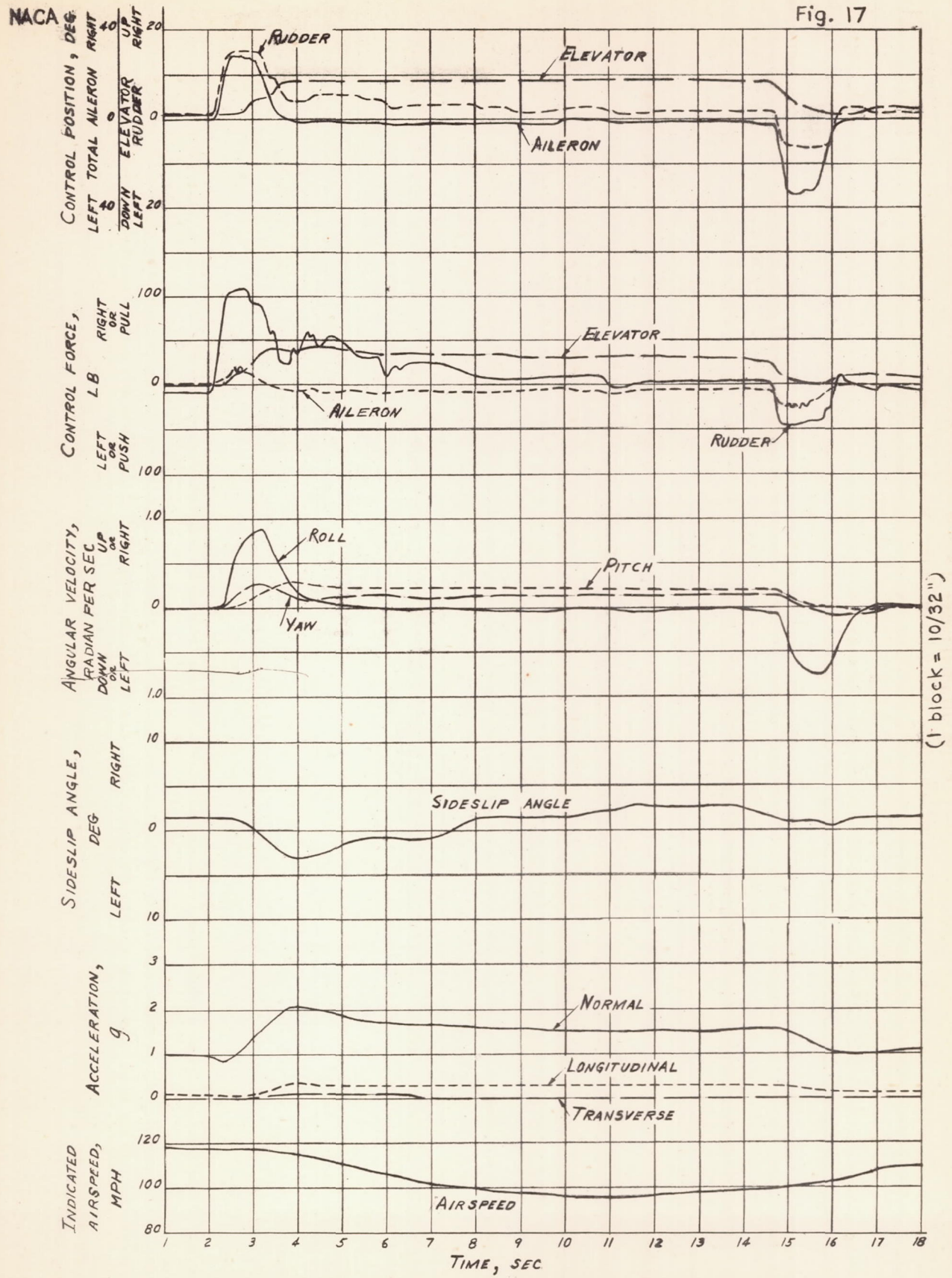

Figure 17. - Time history of a rapid 180° turn to the right started at 118 miles per hour. Brewster X3BA-1 airplane; flaps up, gear up, 18 inches Hg manifold pressure, 1800 rpm.

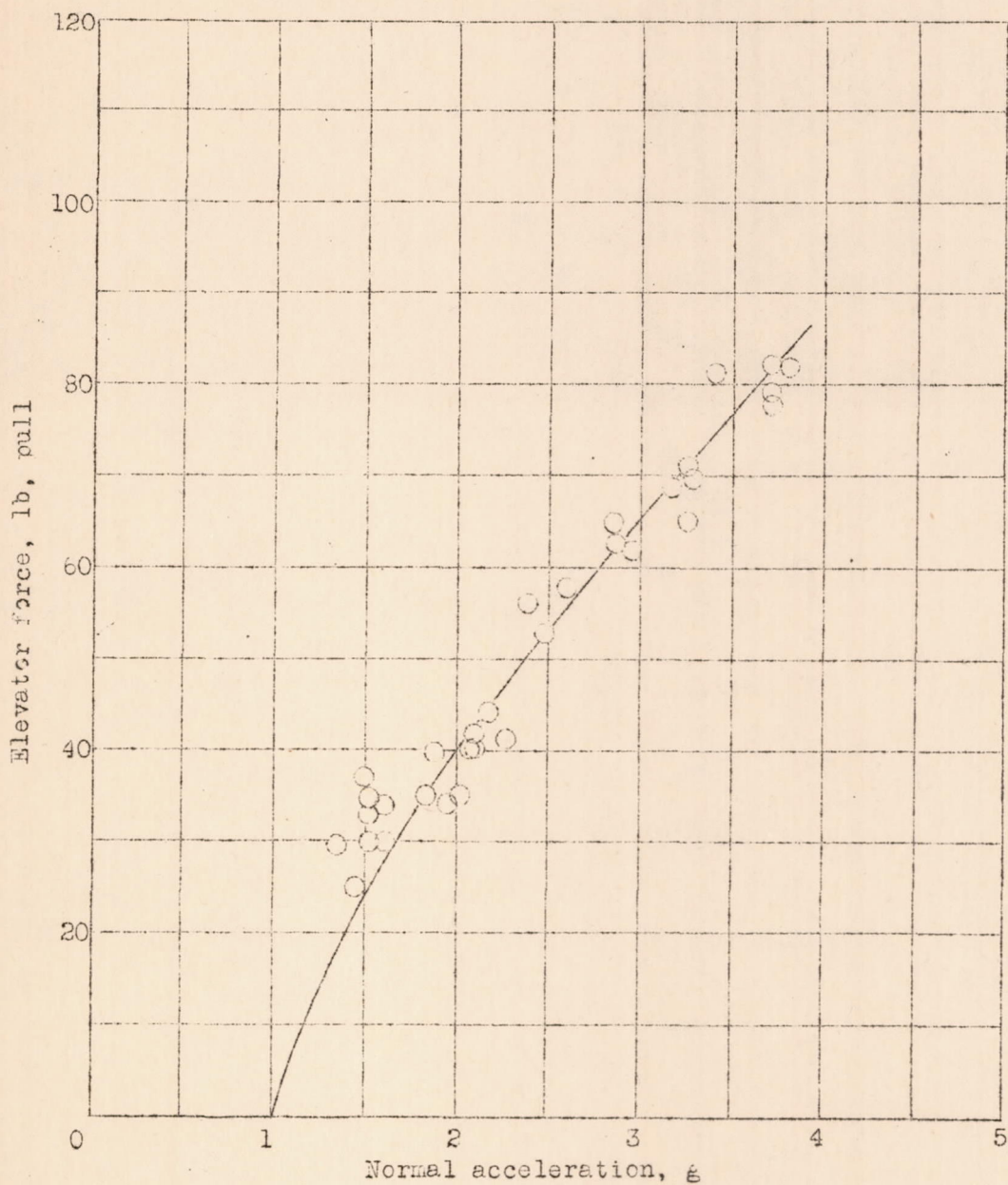

Figure 18.- Variation of elevator stick force with normal acceleration in 180° turns. Brewster XSEA-1 airplane; flaps up, gear up, 18 inches H_g manifold pressure, 1800 rpm.

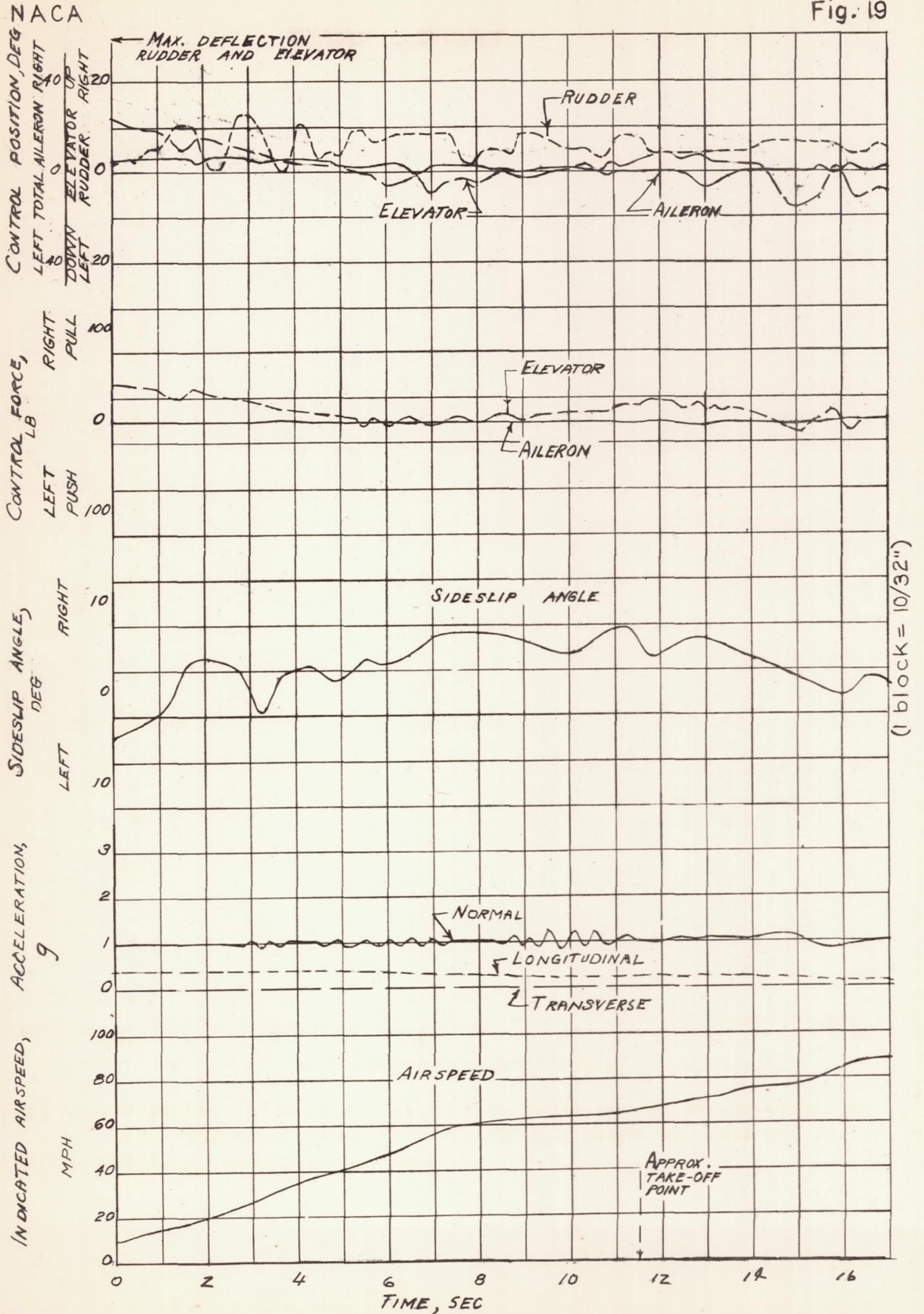

Figure 19. - Time history of a take-off with flaps full down, 35 inches Hg manifold pressure, 2200 rpm. Brewster XSBA-1 airplane.

L-412

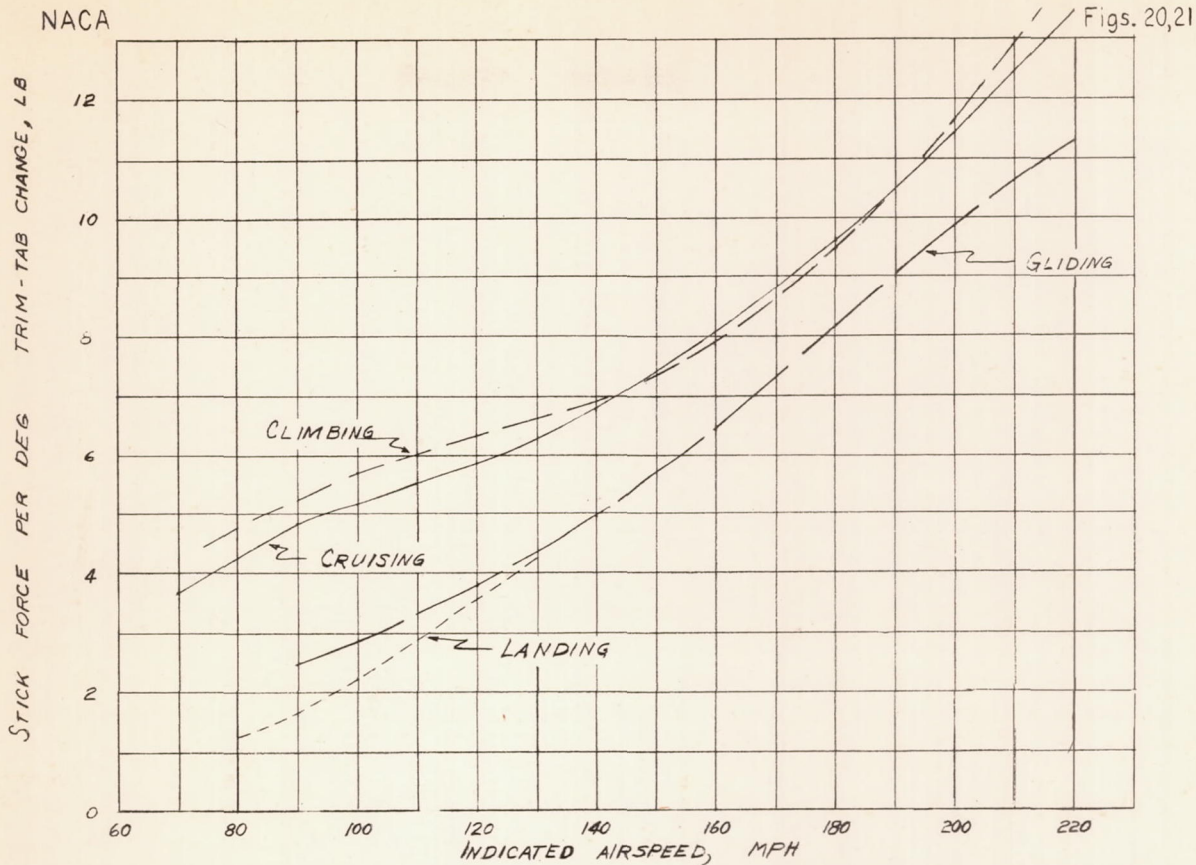

Figure 20. - Variation of stick force per degree trim-tab change with indicated airspeed, Brewster XSBA-1 airplane.

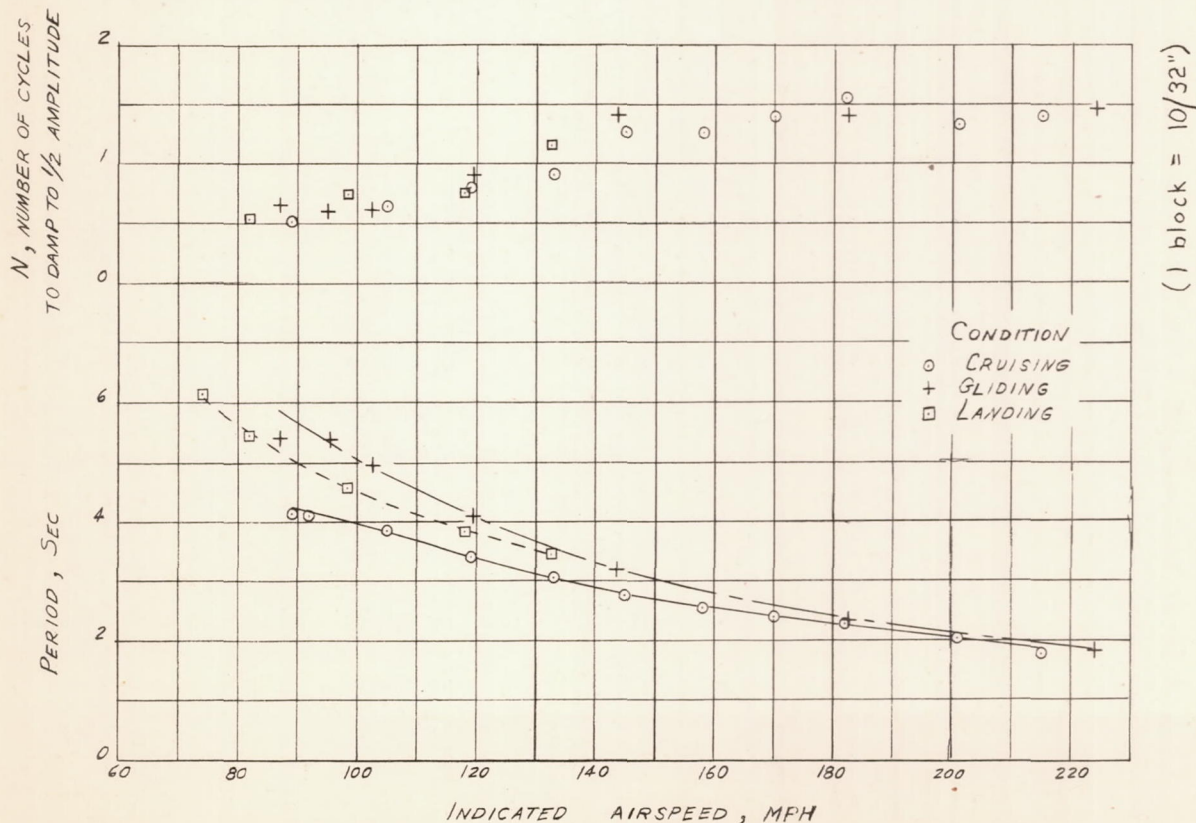

Figure 21. - Variation of period and damping of lateral oscillations with indicated airspeed. Brewster XSBA-1 airplane.

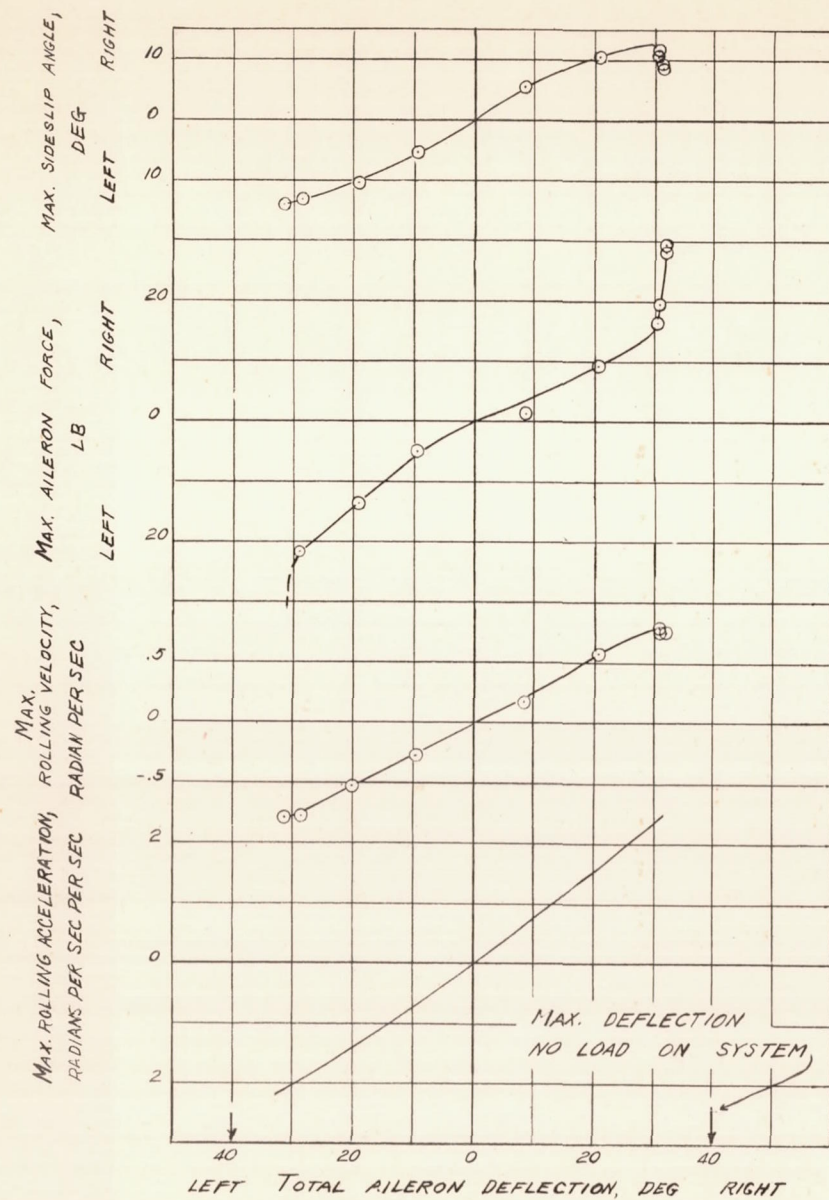

Figure 22. - Variation of maximum sideslip angle, aileron force, rolling velocity, and angular acceleration with aileron deflection in the cruising condition at 119 miles per hour, Brewster XSBA-1 airplane.

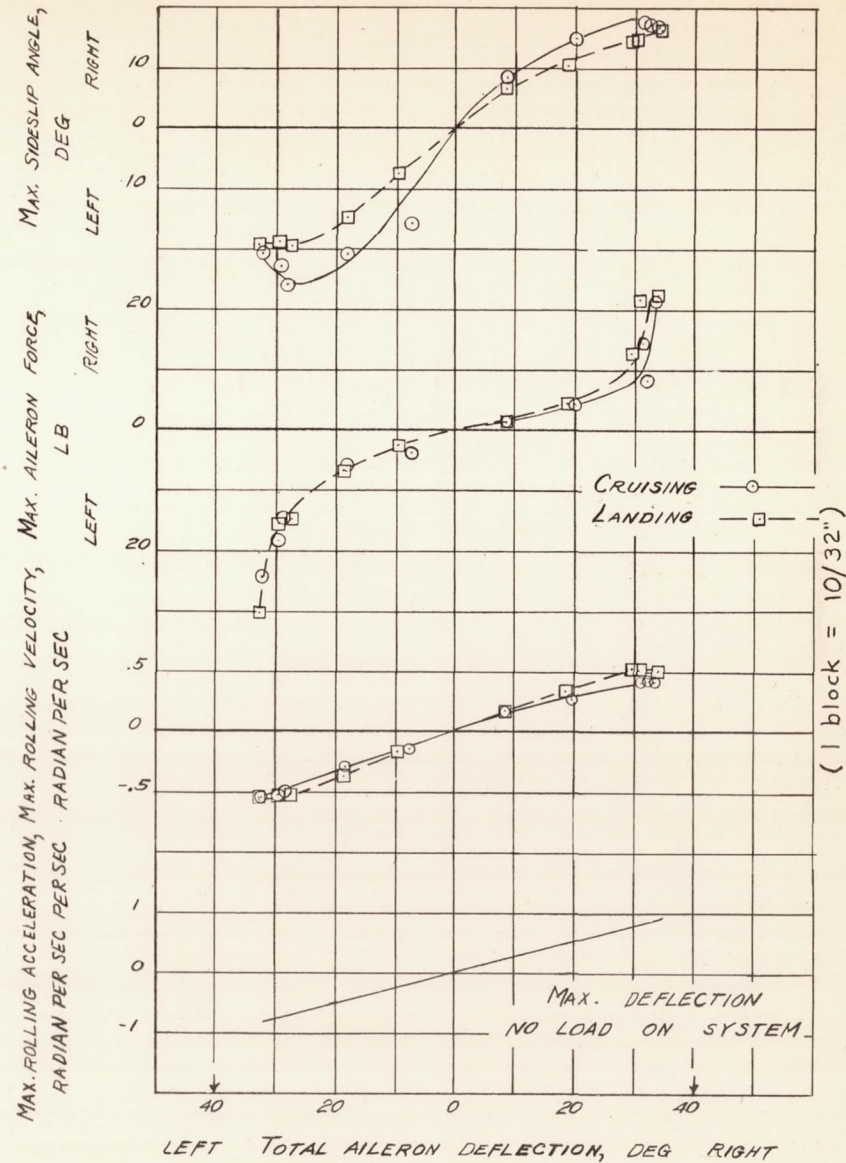

Figure 23. - Variation of maximum sideslip angle, aileron force, rolling velocity, and angular acceleration with aileron deflection in the landing condition at 85 miles per hour and in the cruising condition at 76 miles per hour. Brewster XSBA-1 airplane.

NACA

Figs. 22, 23

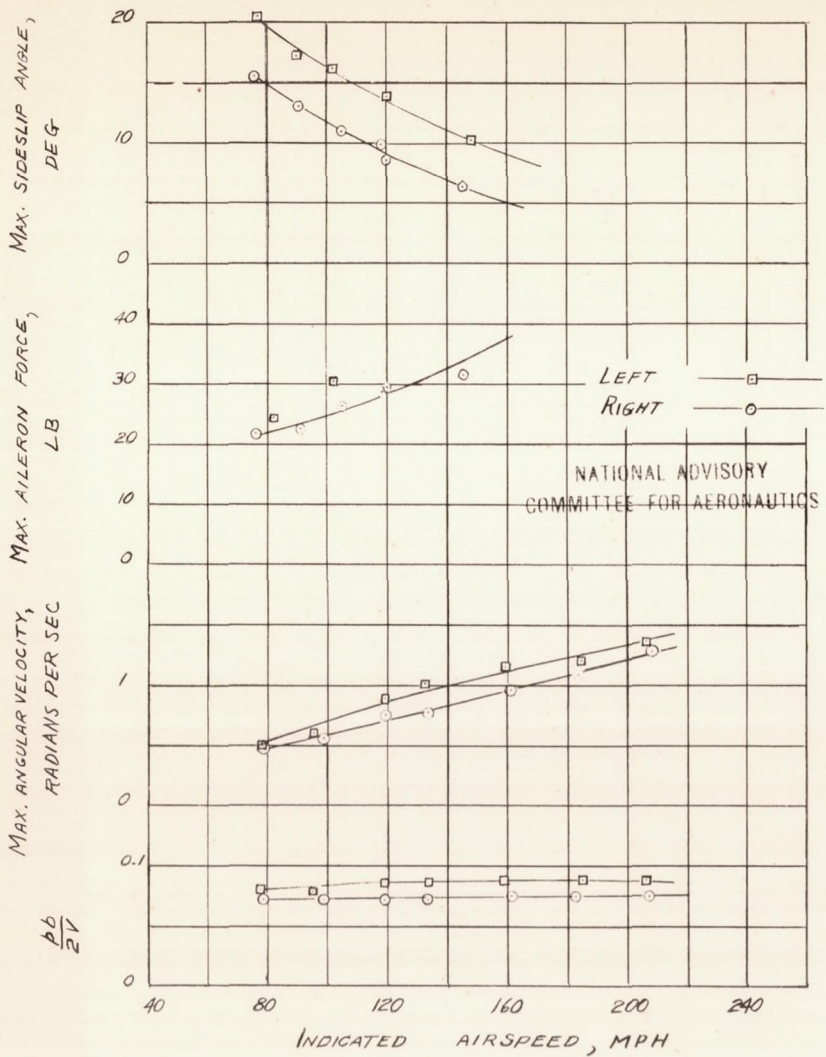

Figure 24. - Variation of maximum sideslip angle, maximum aileron force, maximum rolling velocity, and pb/2V with indicated airspeed in level flight for rolls with full aileron deflection (flaps up, gear up). Brewster XSBA-1 airplane.

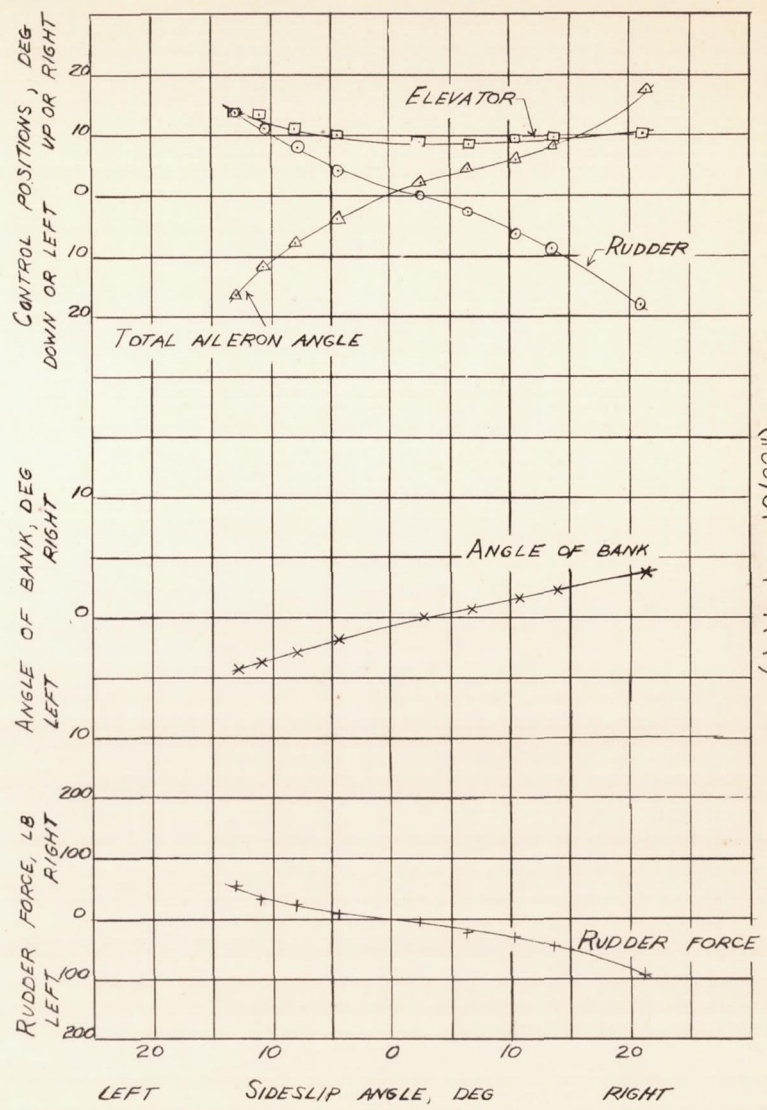

Figure 25. - Steady-sideslip characteristics in the gliding condition at 85 miles per hour (flaps up, gear up, power off). Brewster XSBA-1 airplane.

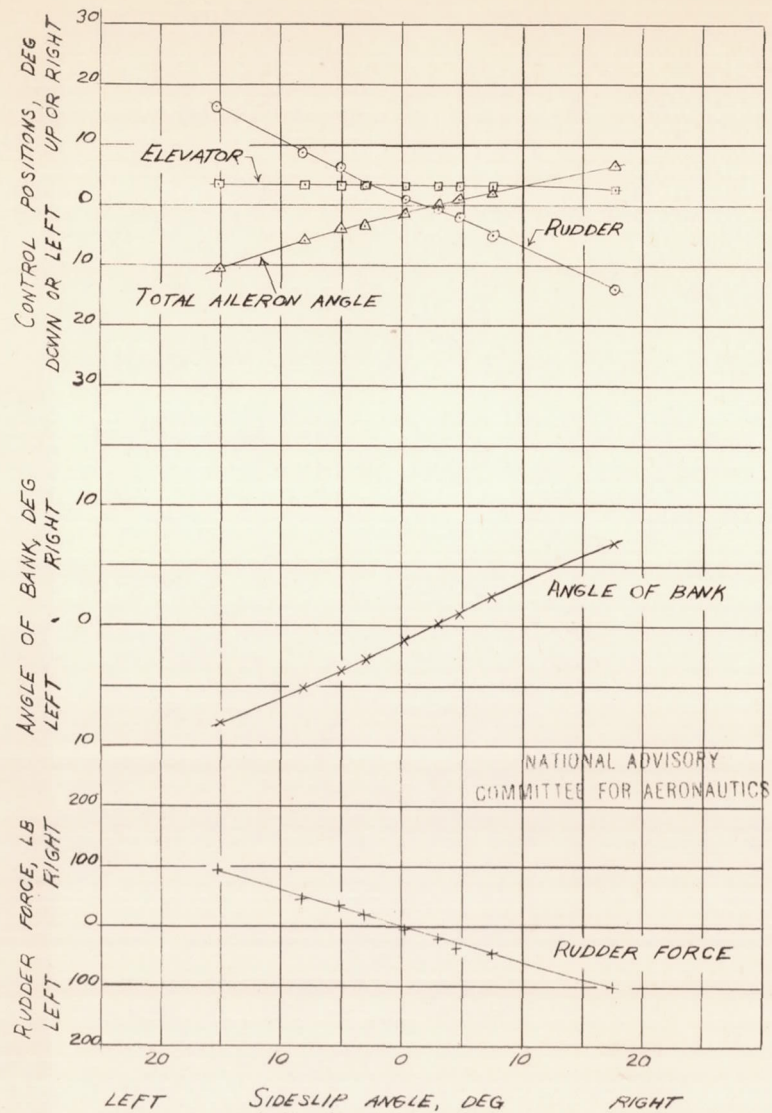

Figure 26. - Steady-sideslip characteristics in the gliding condition at 119 miles per hour (flaps up, gear up, power off). Brewster XSB-1 airplane.

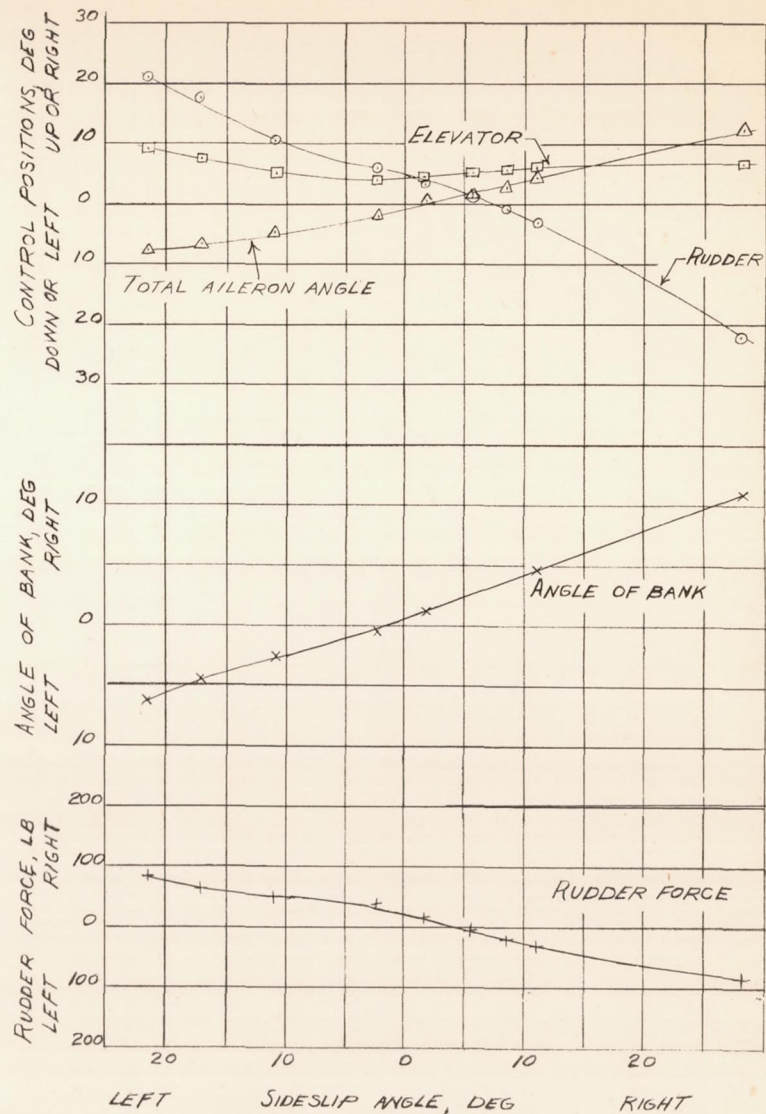

Figure 27. - Steady-sideslip characteristics in the cruising condition at 82 miles per hour (flaps up, gear up, cruising power). Brewster XSB-1 airplane.

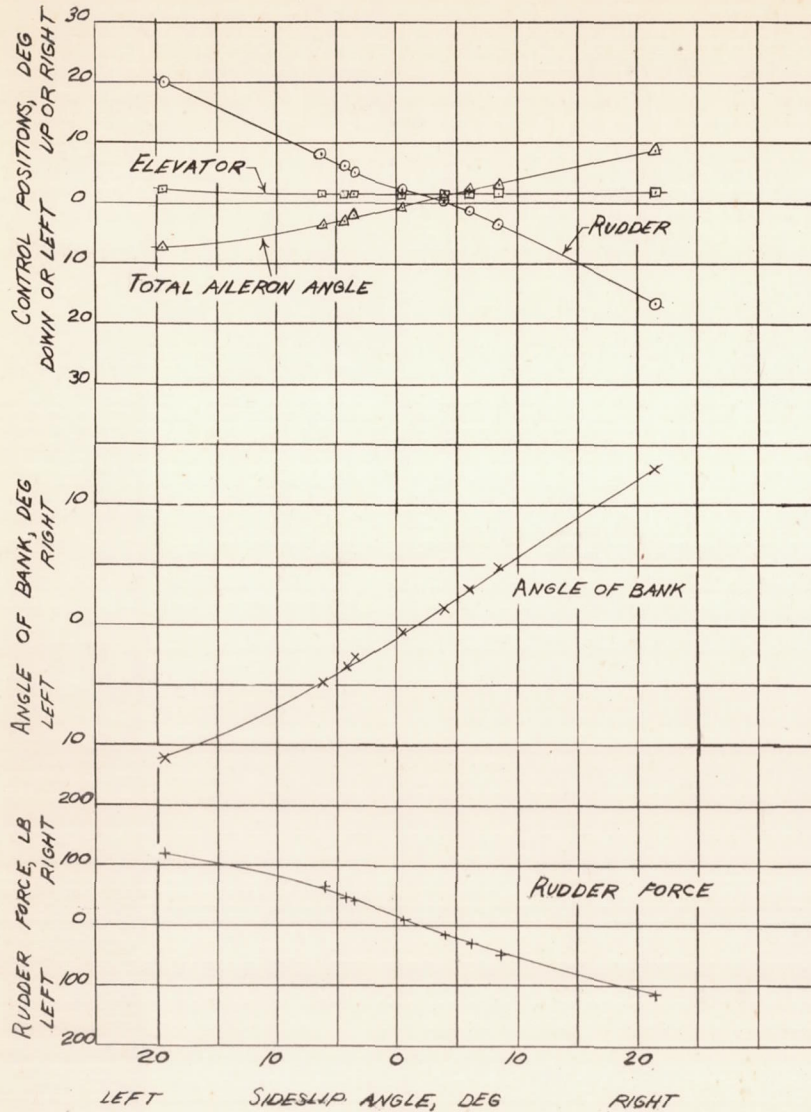

Figure 28. - Steady-sideslip characteristics in the cruising condition at 122 miles per hour (flaps up, gear up, cruising power). Brewster XSBA-1 airplane.

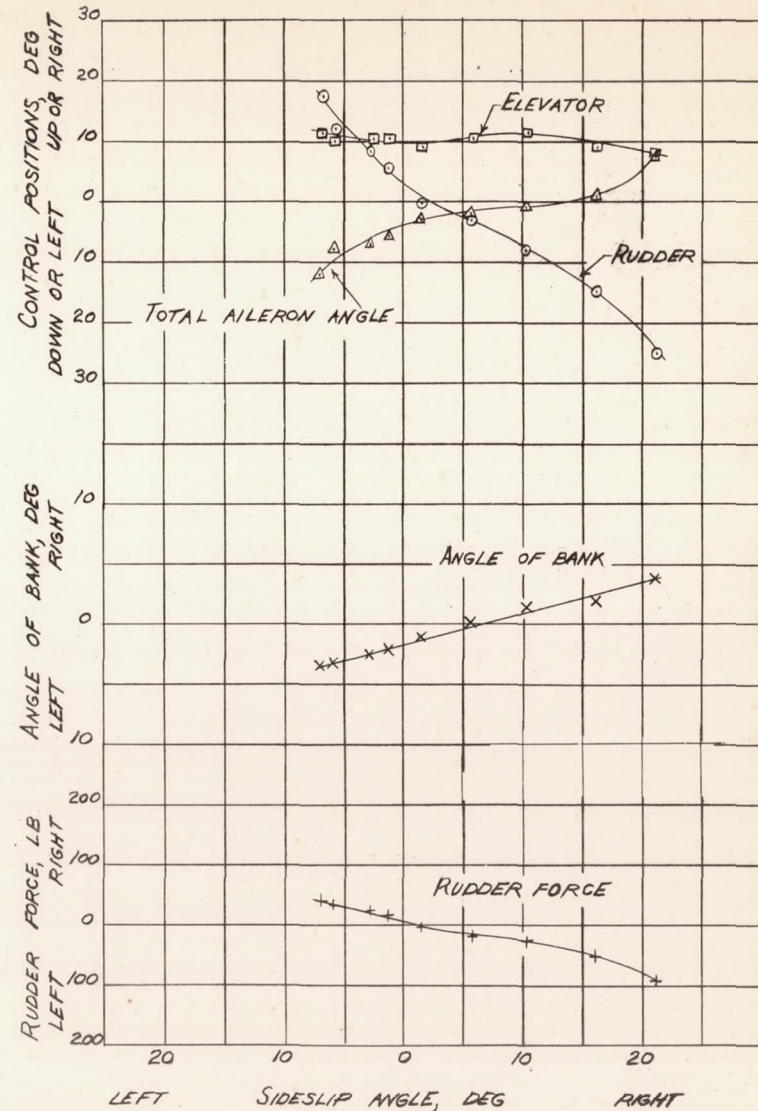

Figure 29. - Steady-sideslip characteristics in the landing condition at 76 miles per hour (flaps down, gear down, power off). Brewster XSBA-1 airplane.

NACA

("10/32" = 1000)

Figs. 28, 29

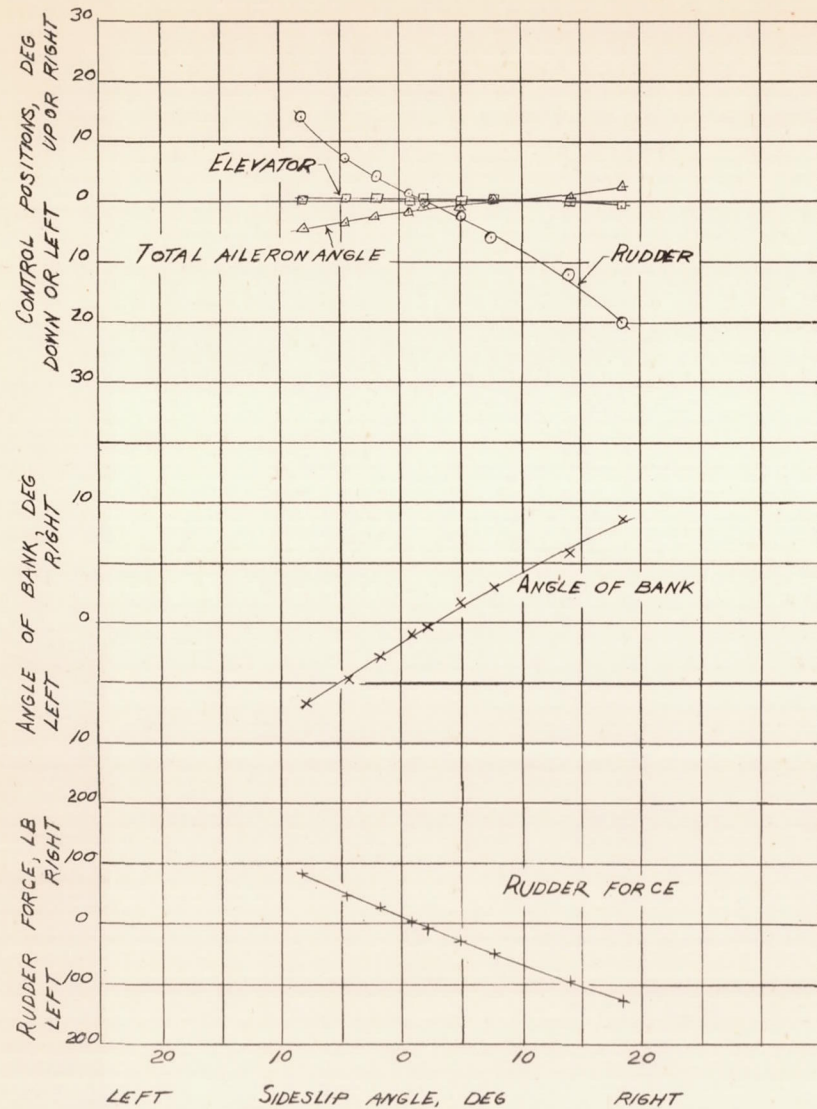

Figure 30. - Steady-sideslip characteristics in the landing condition at 115 miles per hour (flaps down, gear down, power off). Brewster XSBA-1 airplane.

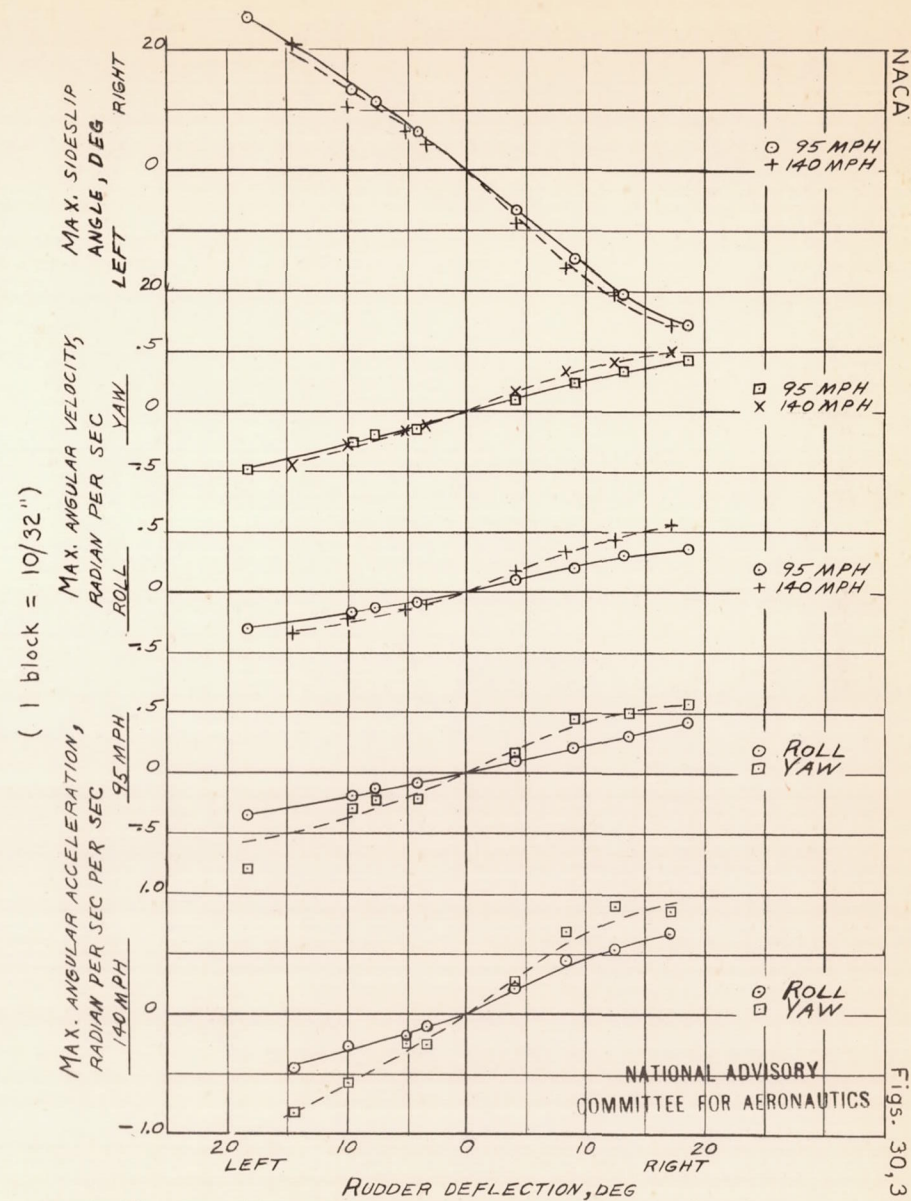

Figure 31.- Variation of maximum values of sideslip angle, angular velocities, and angular accelerations with rudder deflection in abrupt rudder kicks in the cruising condition at 95 and 140 miles per hour (flaps up, gear up, cruising power). Brewster XSBA-1 airplane.

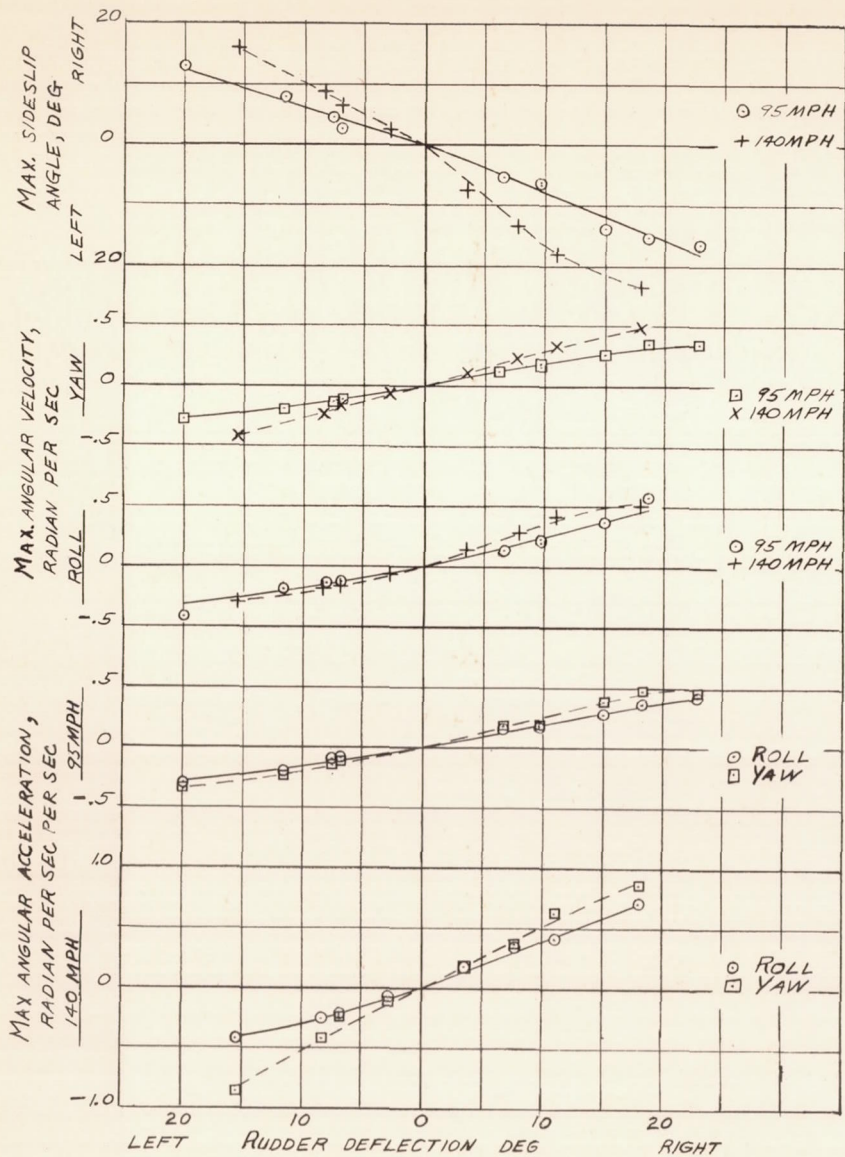

Figure 32. - Variation of maximum values of sideslip angle, angular velocities, and angular accelerations with rudder deflection in abrupt rudder kicks in the landing condition at 95 and 140 miles per hour (flaps up, gear up, power off). Brewster XSBA-1 airplane.

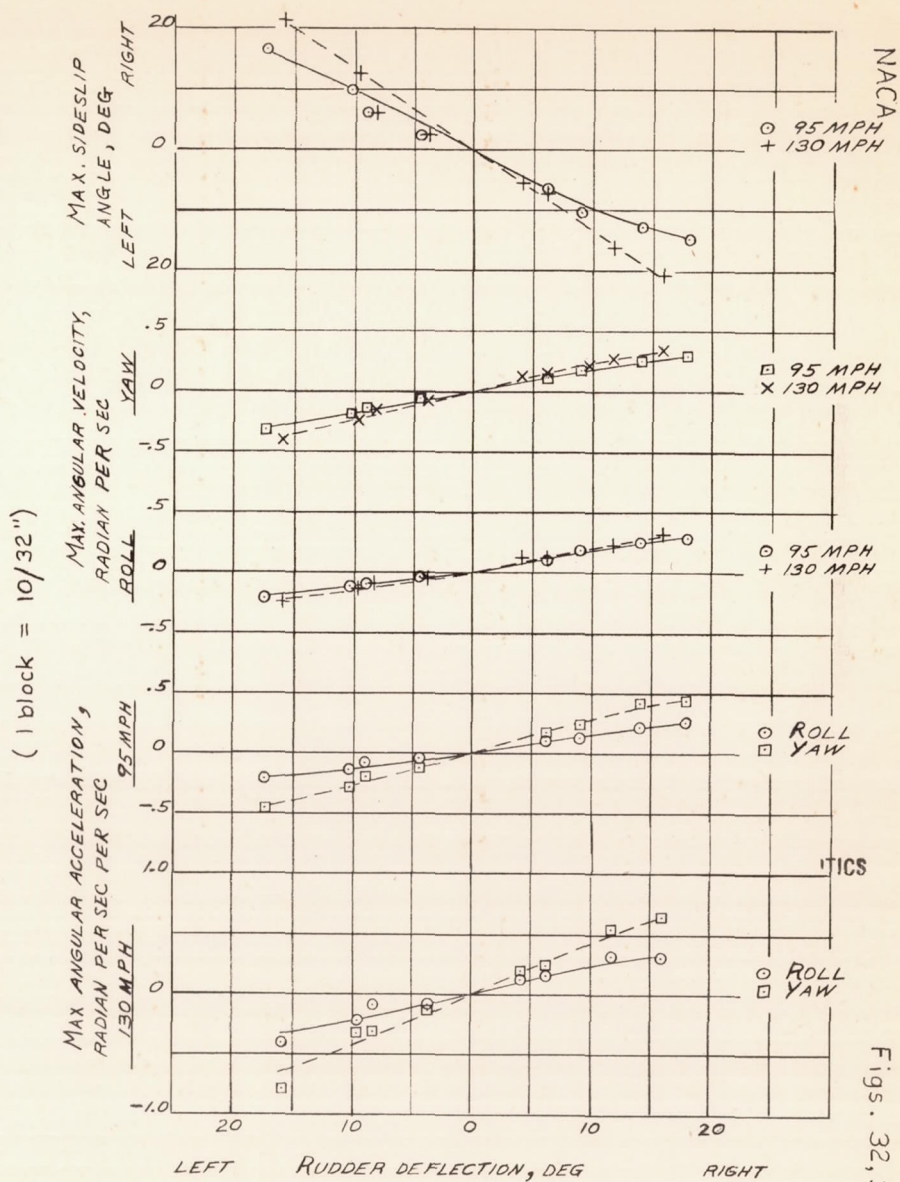

Figure 33. - Variation of maximum values of sideslip angle, angular velocities, and angular accelerations with rudder deflection in abrupt rudder kicks in the landing condition at 95 and 130 miles per hour (flaps down, gear down, power off). Brewster XSBA-1 airplane.

L-412

NACA

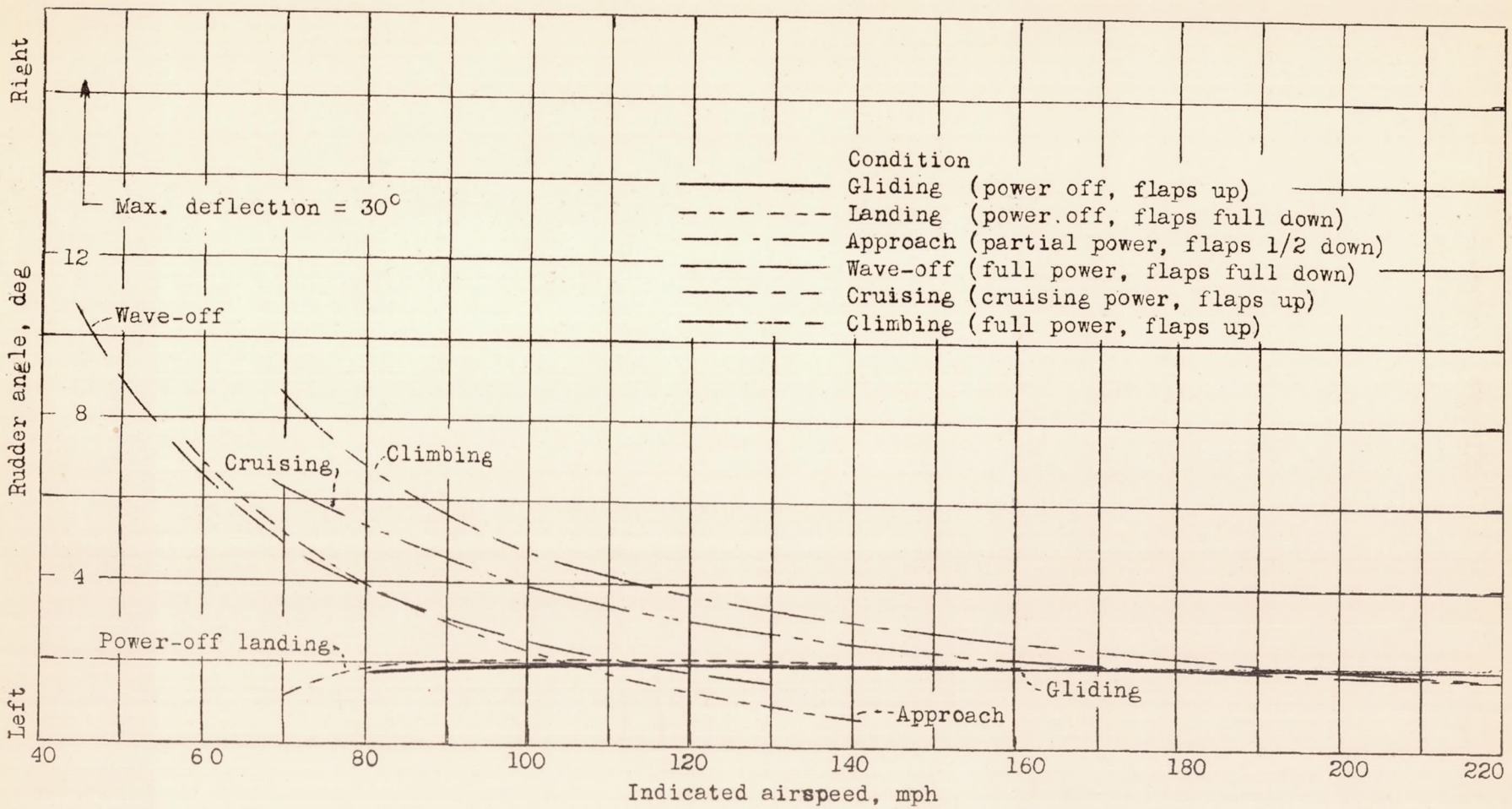
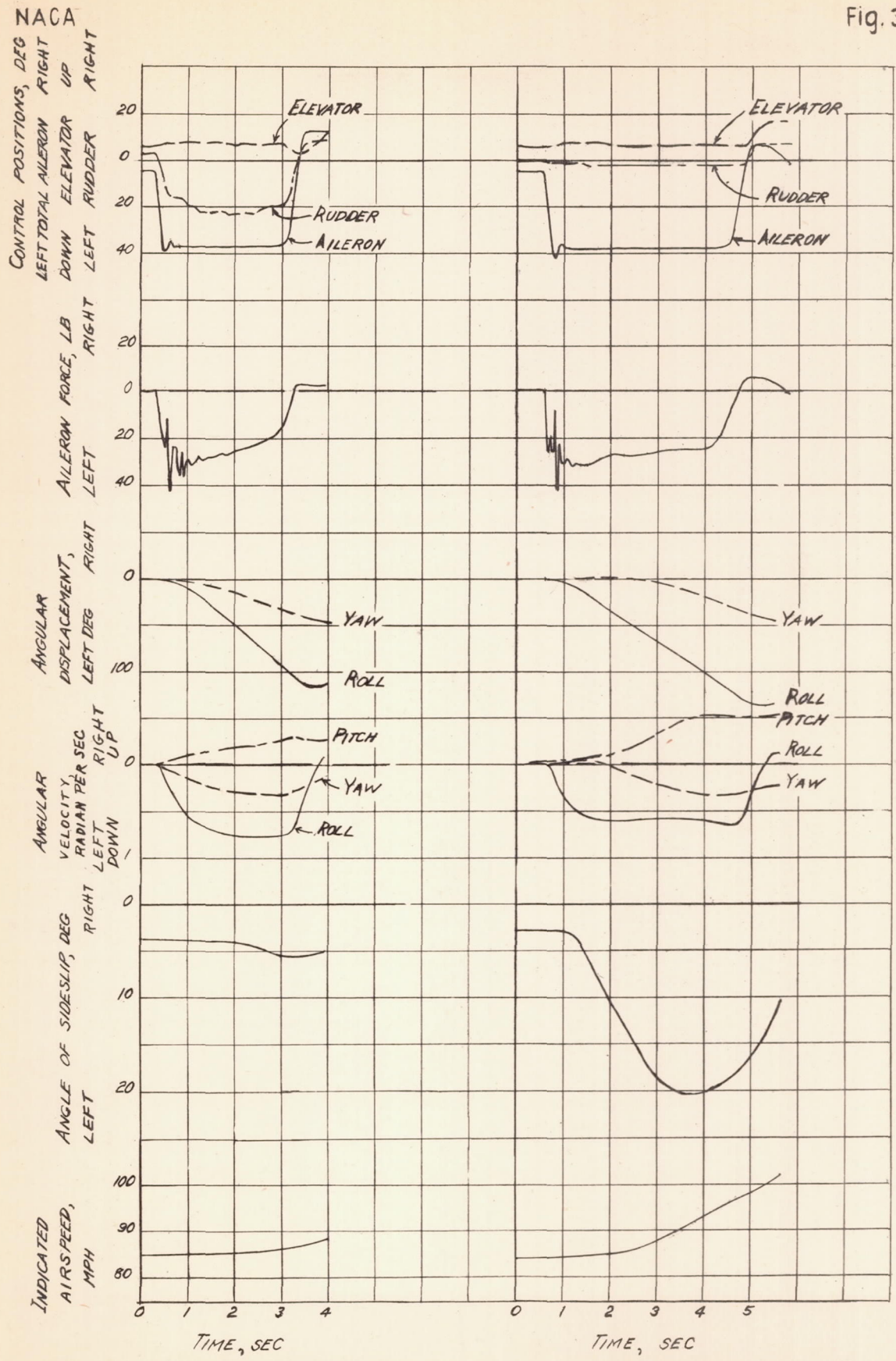

Figure 34.- Variation of rudder angle required for trim with indicated airspeed. Brewster XSBA-1 airplane.

Fig. 34

L-412

Fig. 35



(a) Rudder used to maintain zero sideslip.

(b) Rudder held in trim position.

Figure 35. - Time histories of aileron rolls made in the landing condition.

I-412

NACA

Fig. 36

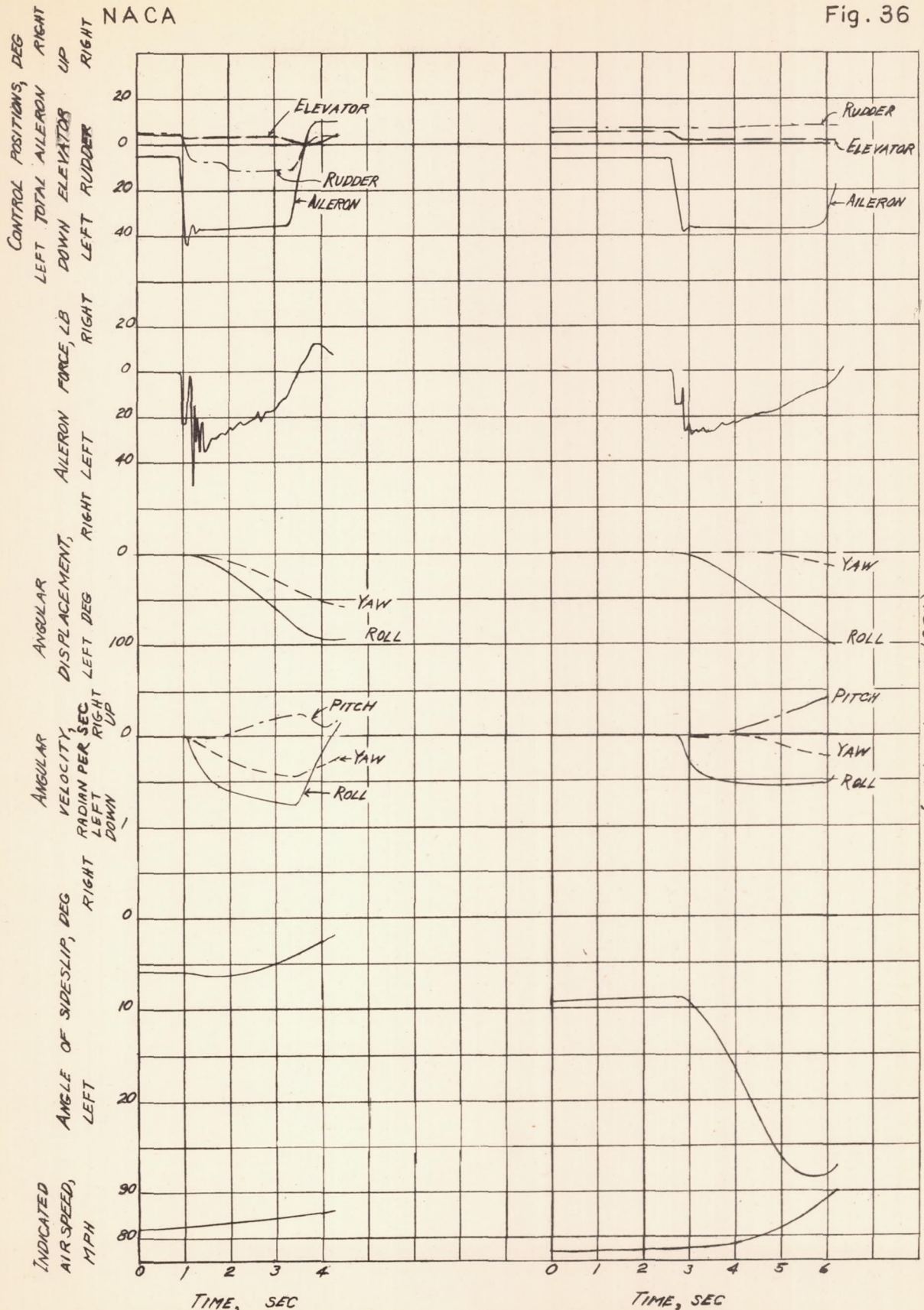

(a) Rudder used to maintain zero sideslip.

(b) Rudder held in trim position.

Figure 36. - Time histories of aileron rolls made in the cruising condition.

I-412

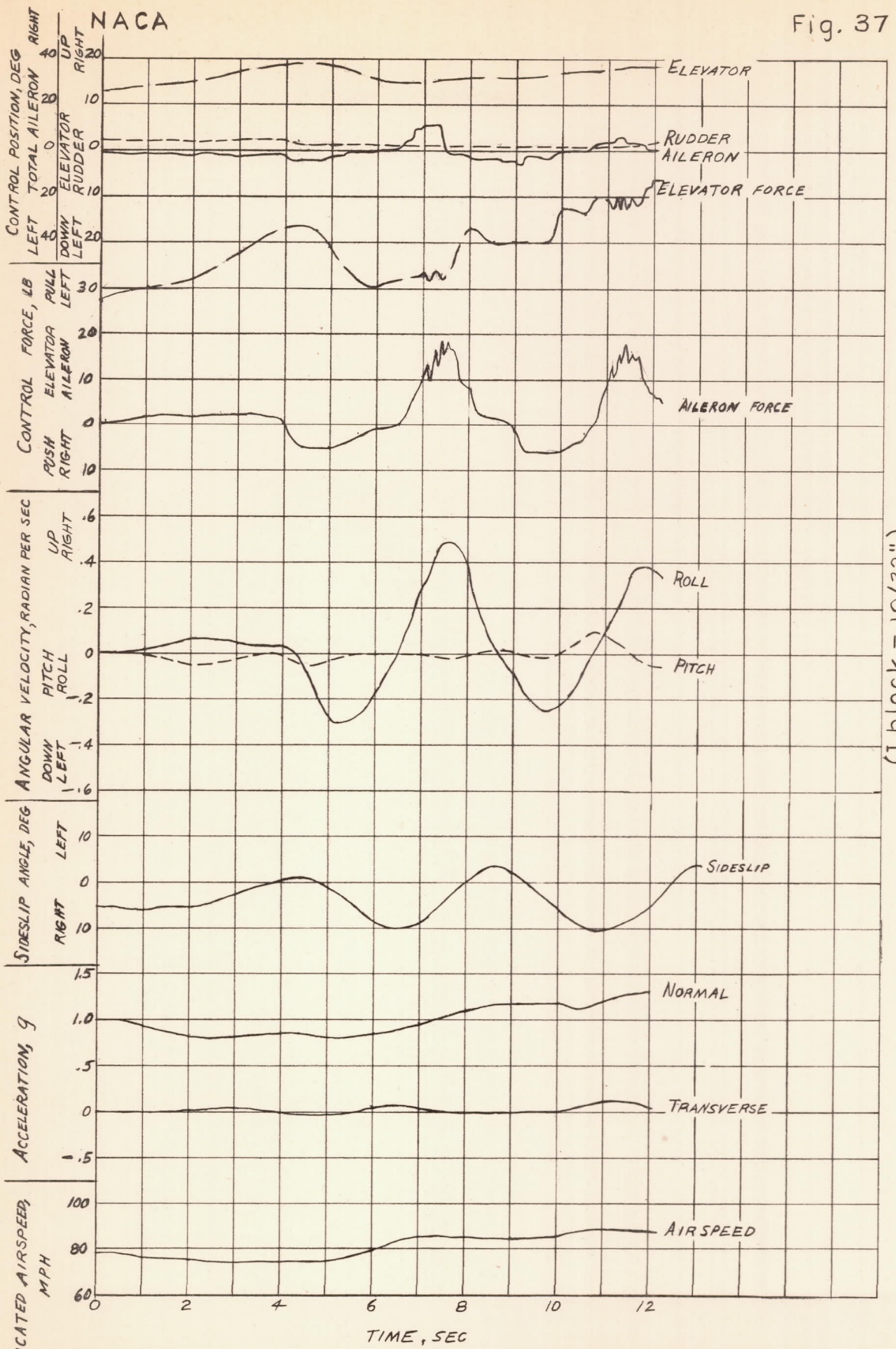

Figure 37. - Time history of a stall in gliding condition (flaps up, gear up, power off) with controls held fixed. Airplane performs rolling oscillation of constant amplitude. Brewster XSBA-1 airplane.

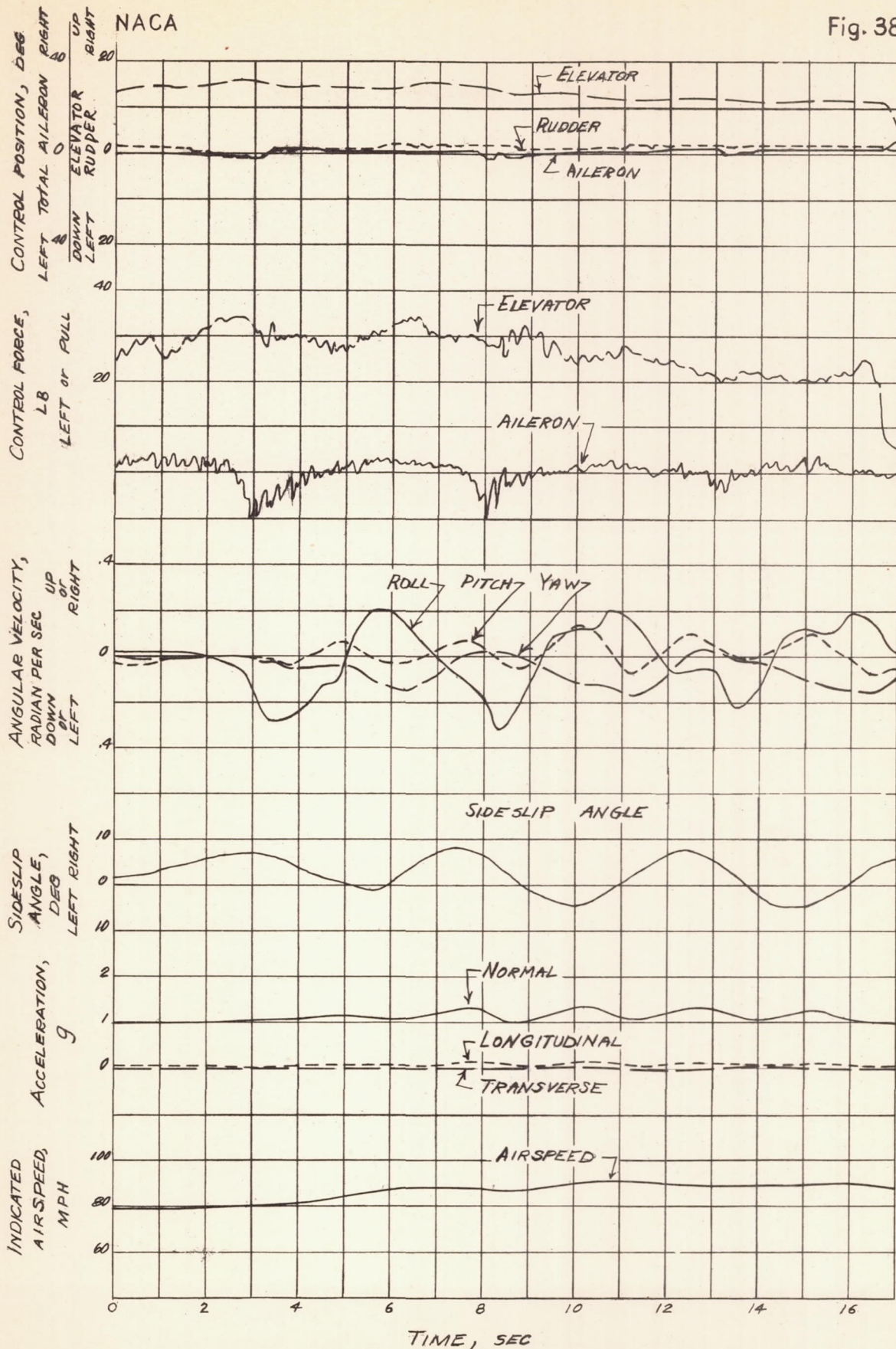

Figure 38. - Time history of a stall in gliding condition (flaps up, gear up, power off) holding controls fixed. Note complicated rolling and pitching oscillation of constant amplitude. Pitching oscillation has twice frequency of rolling oscillation. Brewster XSBA-1 airplane.

L-412

Fig. 39

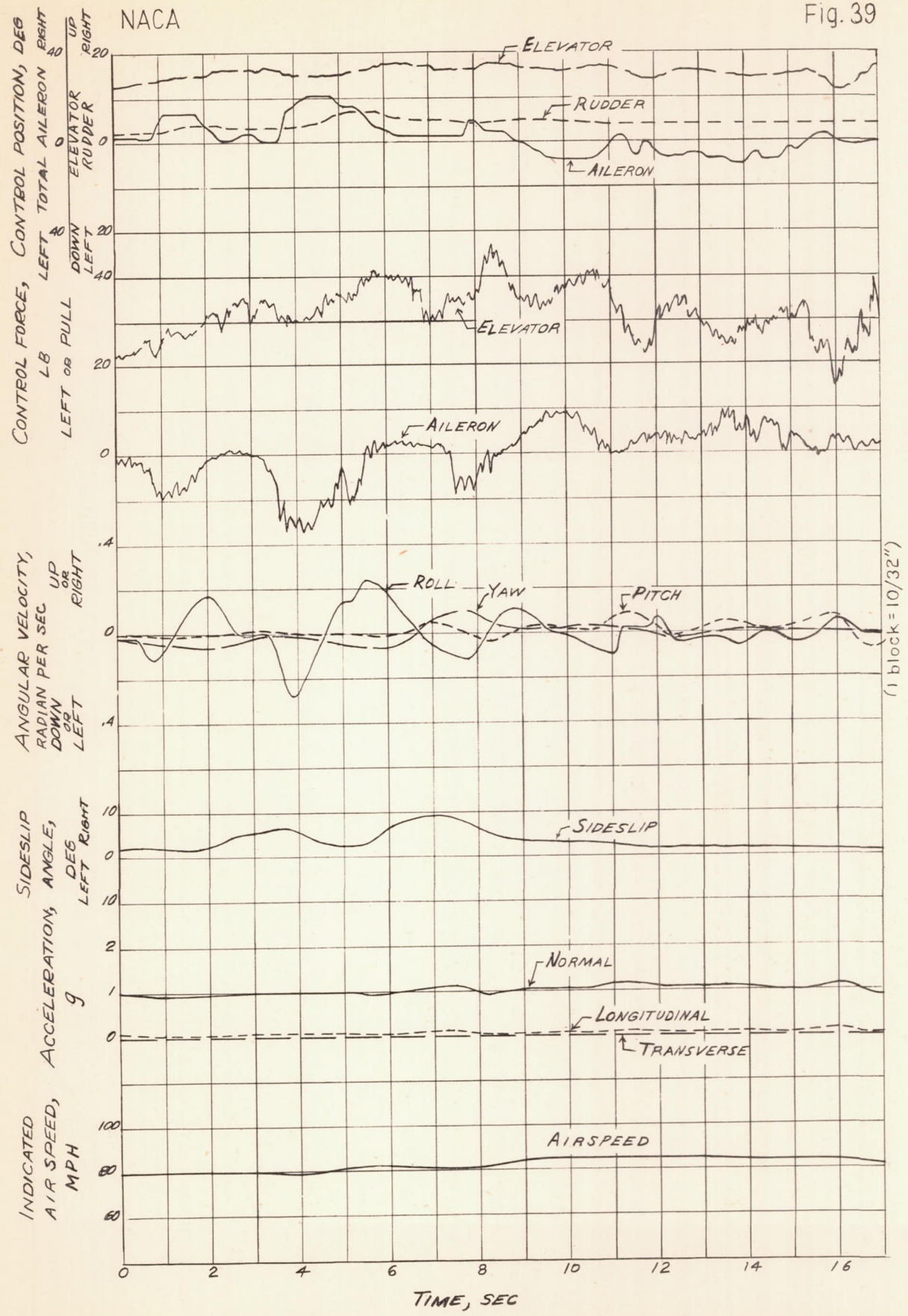

Figure 39. - Time history of a stall in the gliding condition (flaps up, gear up, power off) Control is maintained by use of the ailerons. Brewster XSBA-1 airplane.

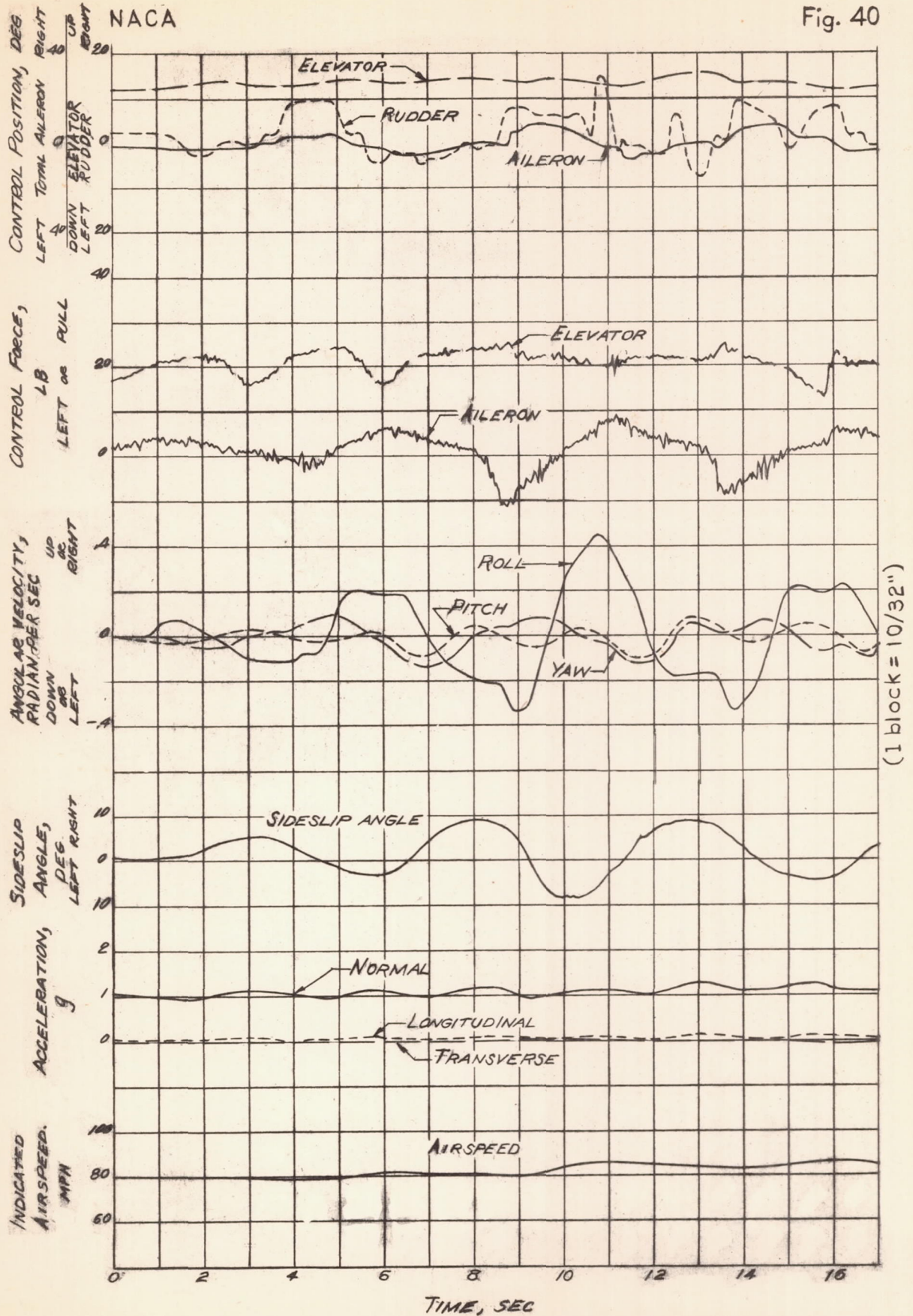

Figure 40. - Time history of a stall in the gliding condition (flaps up, gear up, power off). Control is maintained by use of the rudder. Brewster XSEA-1 airplane.

I-412

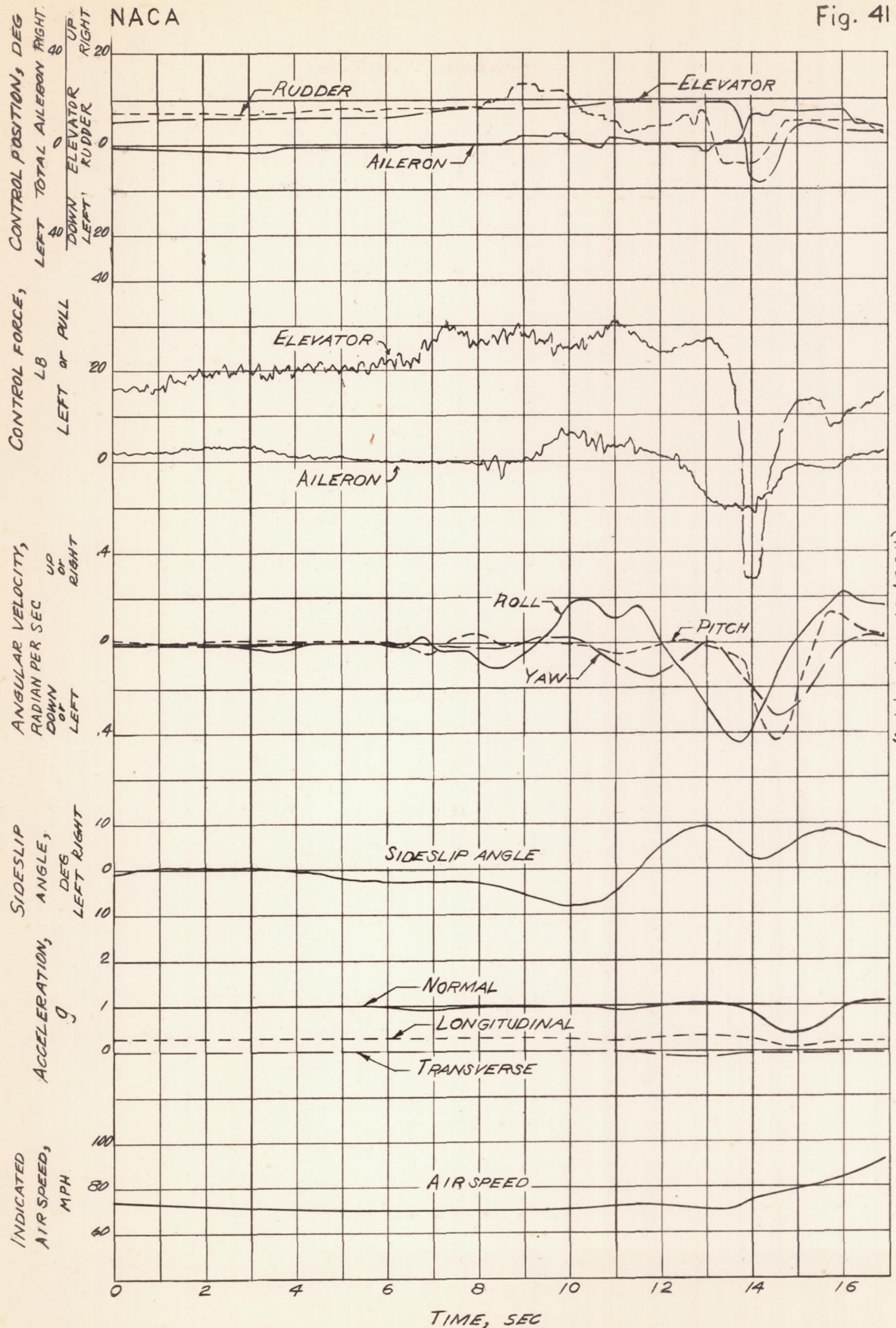

Figure 41. - Time history of a stall in the cruising condition (flaps up, gear up, 23 inches Hg manifold pressure, 1750 rpm). Control was maintained by use of rudder until roll-off to the left occurred. Brewster XSBA-1 airplane.

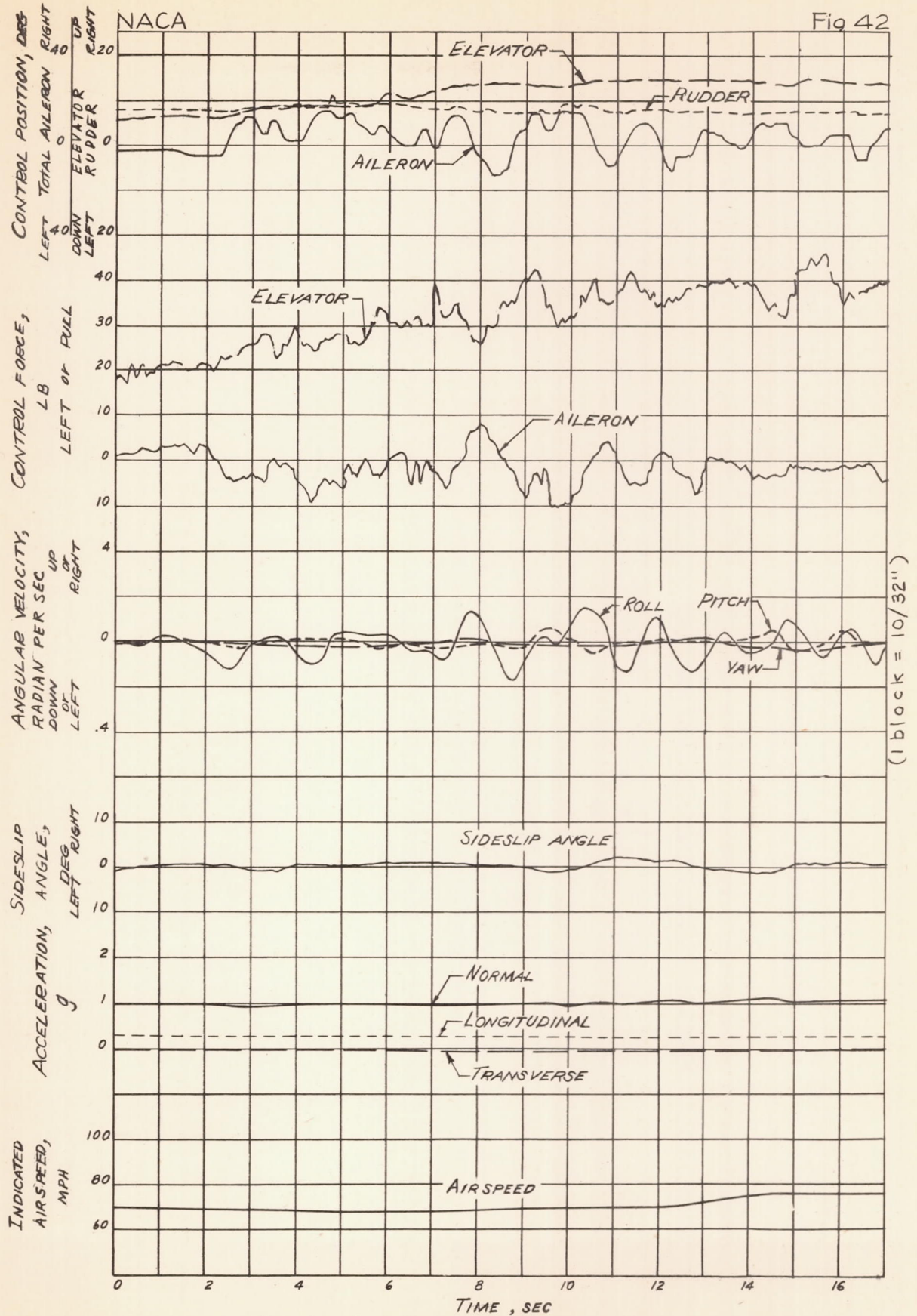

Figure 42. - Time history of a stall in the cruising condition (flaps up, gear up, 23 inches Hg manifold pressure, 1750 rpm). Control is effectively maintained by use of the ailerons. Brewster XSBA-1 airplane.

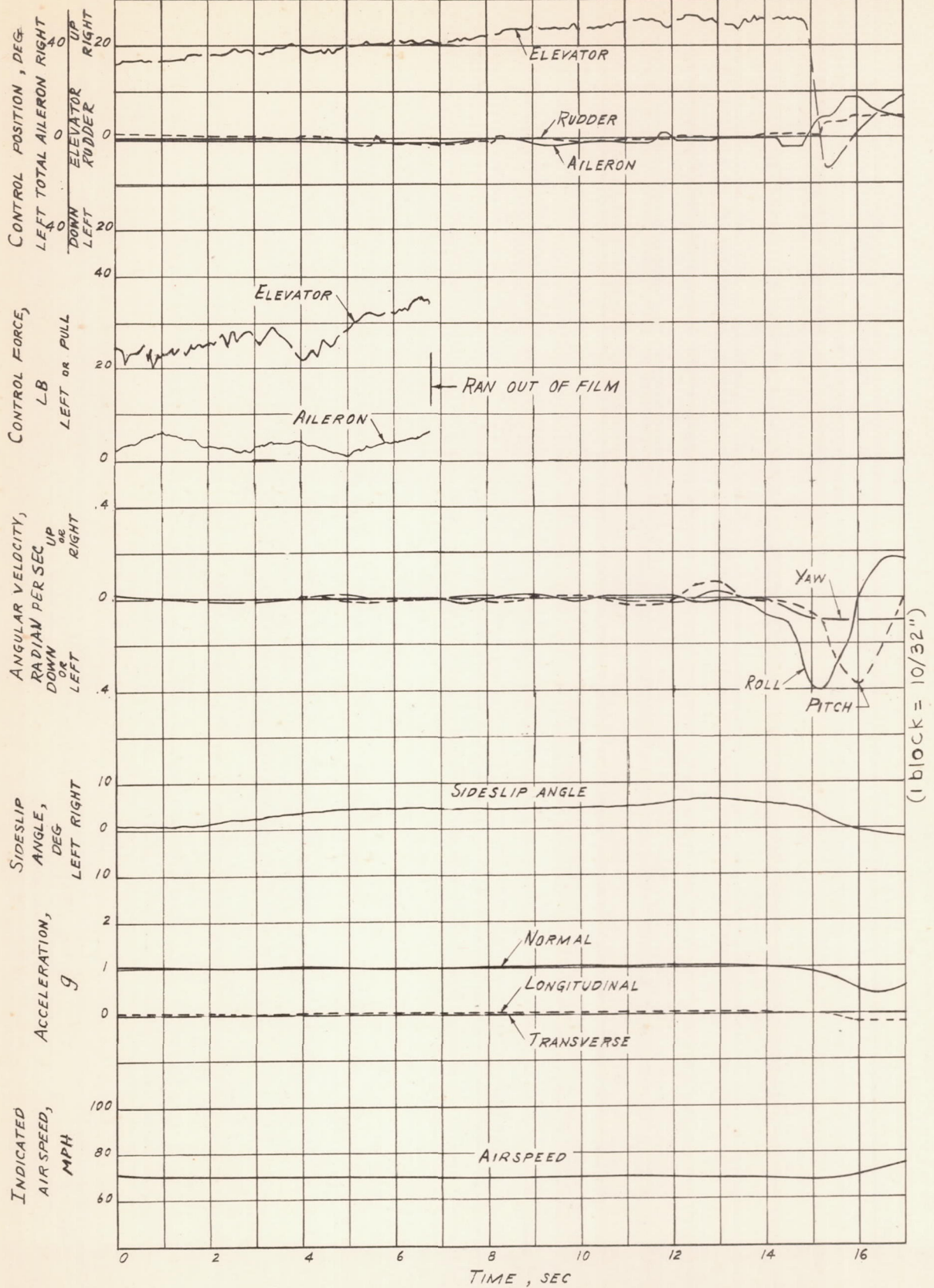

Figure 43. - Time history of a stall in the landing condition (flaps down, gear down, power off). Controls held fixed until roll-off to left occurred. Note adequate stall warning in form of slight rolling and pitching oscillations. Brewster XSBA-1 airplane.

L-412

Fig. 44

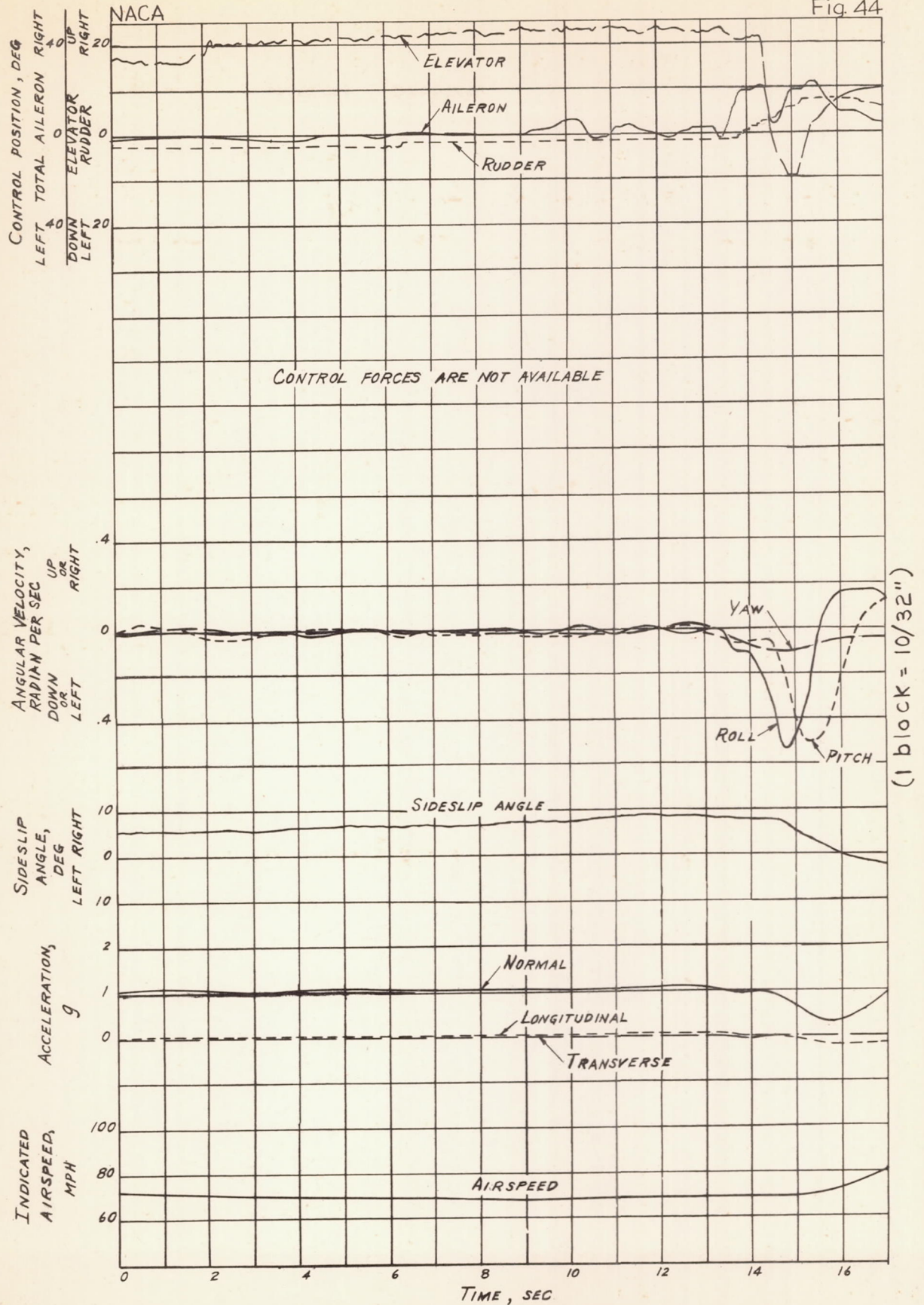

Figure 44. - Time history of a stall in the landing condition (flaps down, gear down, power off). Control attempted with aileron was ineffective in preventing roll-off to left. Brewster XSBA-1 airplane. .1

L-412

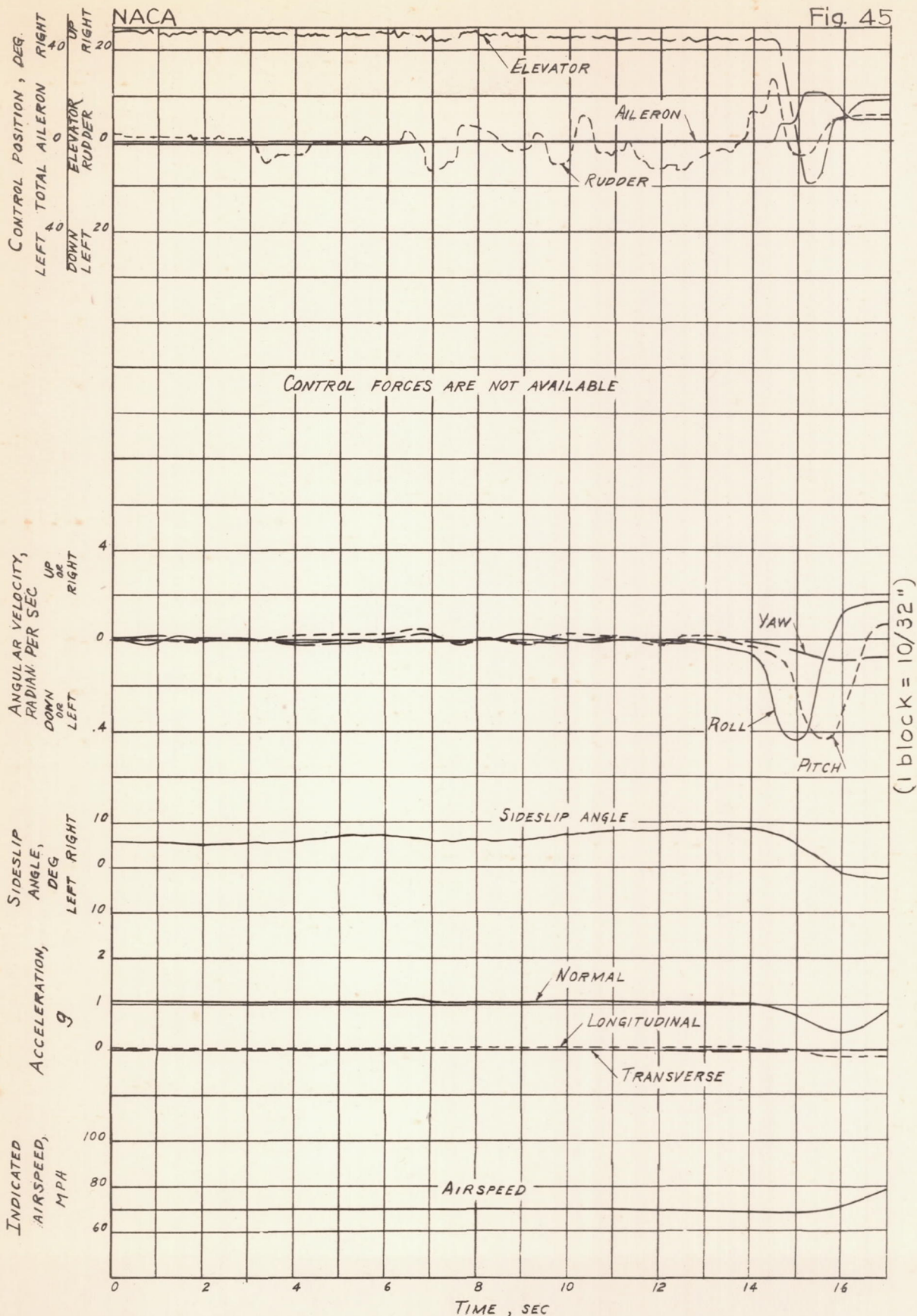

Figure 45. - Time history of a stall in the landing condition (flaps down, gear down, power off). Control maintained by use of rudder until roll-off to the left occurred. Brewster XSBA-1 airplane.

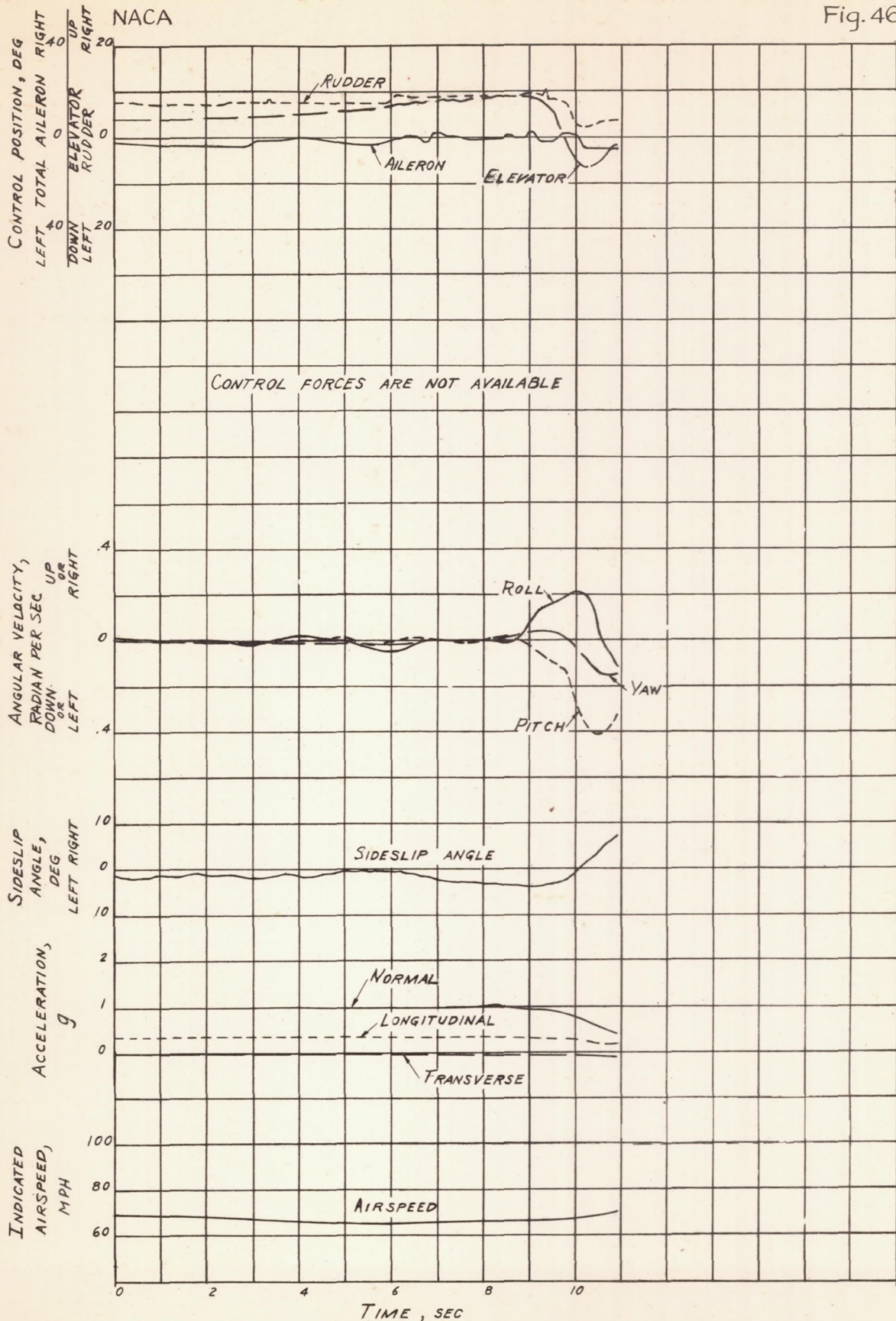

Figure 46. - Time history of a stall in the take-off condition (flaps up, gear down, 35 inches Hg manifold pressure, 2050 rpm). Controls held fixed until mild roll-off to right occurred. Note stall warning in form of rolling and pitching oscillation. Brewster XSBA-1 airplane.

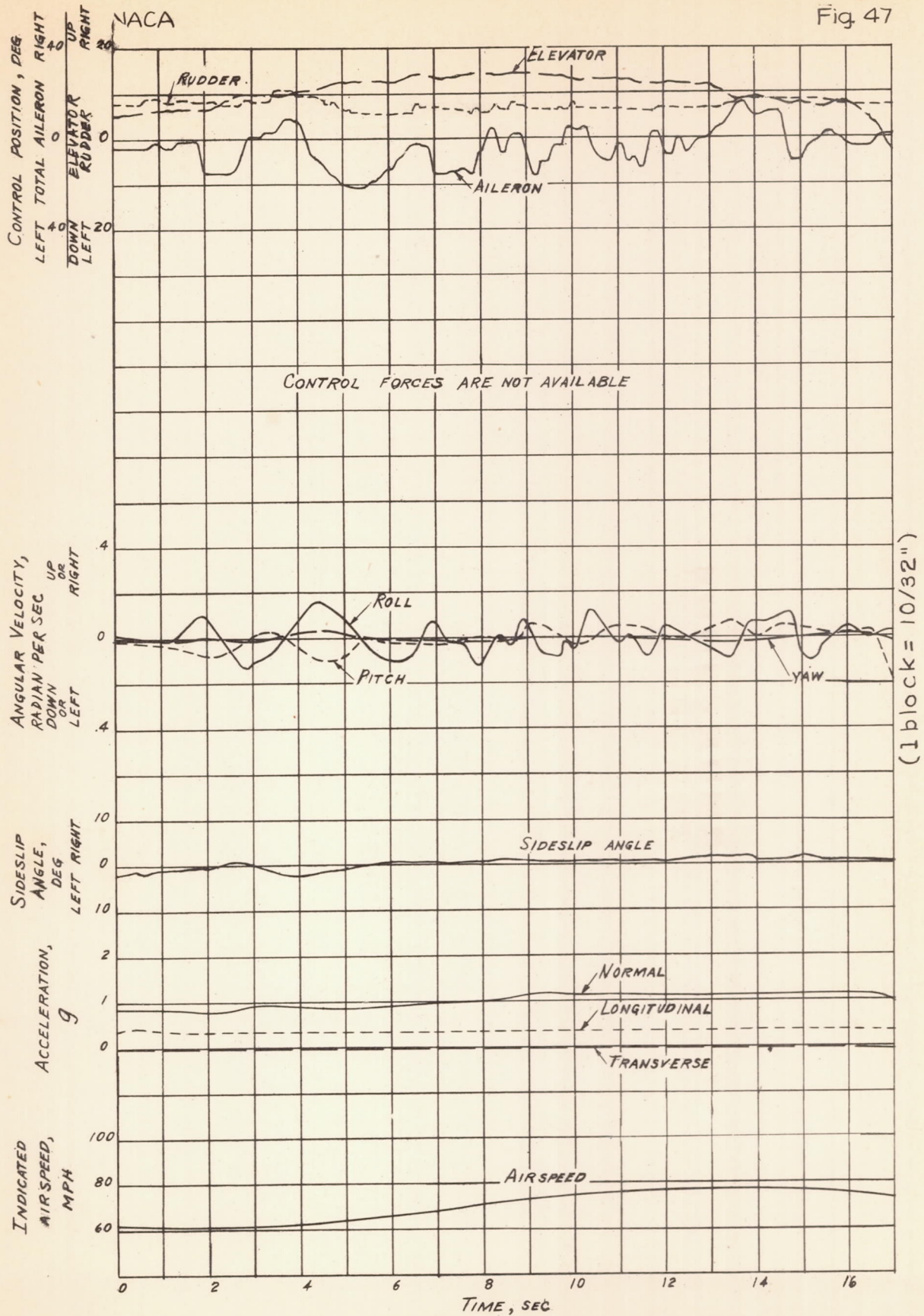

Figure 47. - Time history of a stall in the take-off condition (flaps up, gear down, 35 inches Hg manifold pressure, 2050 rpm). Control maintained by use of the ailerons. Brewster XSBA-1 airplane.

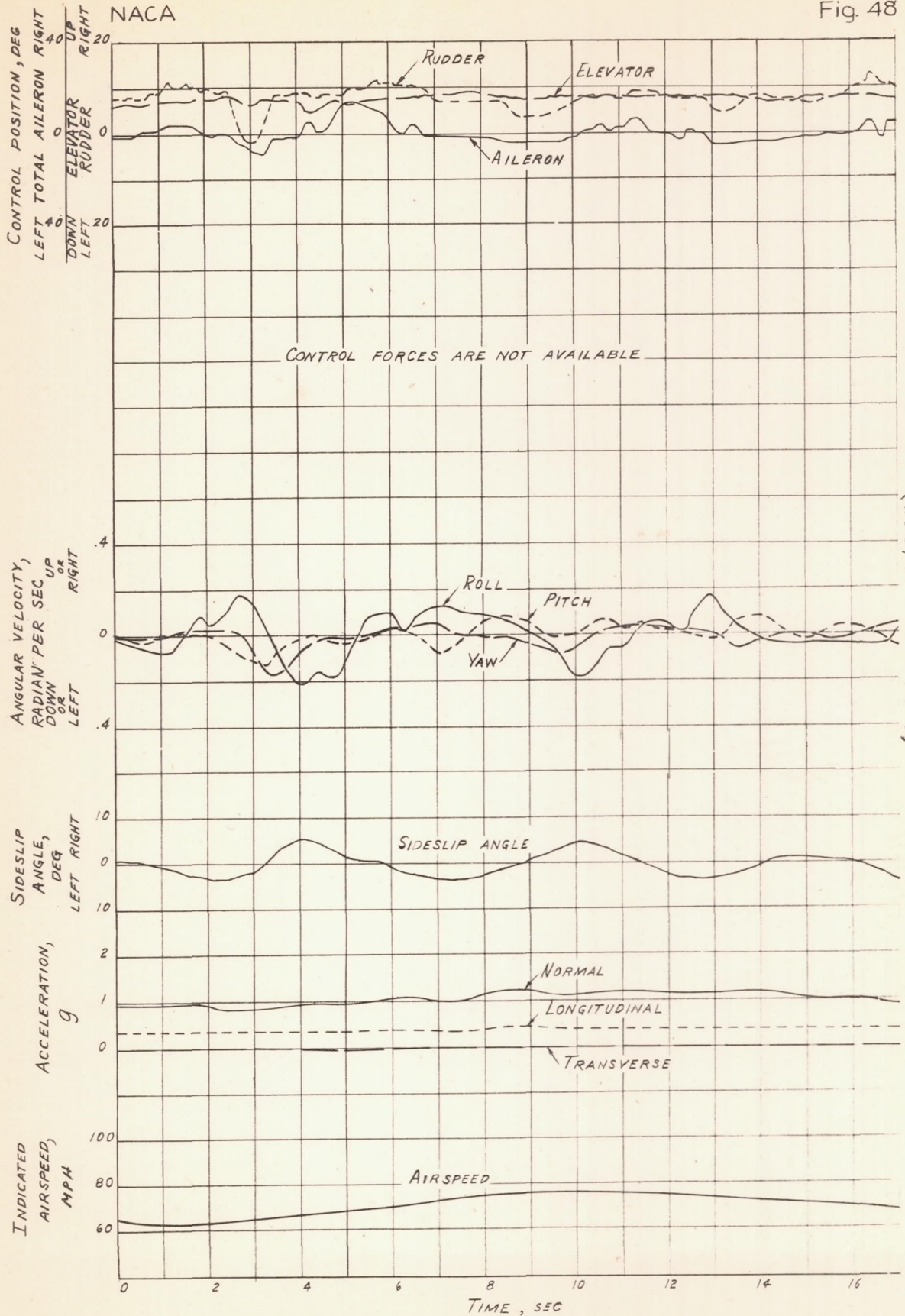

Figure 48. - Time history of a stall in the take-off condition (flaps up, gear down, 35 inches Hg manifold pressure, 2050 rpm). Control is maintained by use of the rudder, though rolling oscillation is rather violent. Brewster XSBA-1 airplane.