

L-598

NATIONAL ADVISORY COMMITTEE FOR AERONAUTICS

JPL LIBRARY

CALIFORNIA INSTITUTE OF TECHNOLOGY

WARTIME REPORT

ORIGINALLY ISSUED

December 1943 as
Memorandum Report

FLIGHT TESTS OF VARIOUS TAIL MODIFICATIONS ON

THE BREWSTER XSBA-1 AIRPLANE

II - MEASUREMENTS OF FLYING QUALITIES WITH

TAIL CONFIGURATION NUMBER TWO

By W. H. Phillips and H. L. Crane

Langley Memorial Aeronautical Laboratory
Langley Field, Va.



WASHINGTON

NACA WARTIME REPORTS are reprints of papers originally issued to provide rapid distribution of advance research results to an authorized group requiring them for the war effort. They were previously held under a security status but are now unclassified. Some of these reports were not technically edited. All have been reproduced without change in order to expedite general distribution.

MEMORANDUM REPORT

for the

Bureau of Aeronautics, Navy Department

FLIGHT TESTS OF VARIOUS TAIL MODIFICATIONS ON

THE BREWSTER XSBA-1 AIRPLANE

II - MEASUREMENTS OF FLYING QUALITIES WITH

TAIL CONFIGURATION NUMBER TWO

By W. H. Phillips and H. L. Crane

INTRODUCTION

At the request of the Bureau of Aeronautics, Navy Department, a series of tests on the Brewster XSBA-1 airplane is being conducted to determine the effects of various tail modifications. The modifications are to include (1) variation of the chord of the elevator and rudder while the total area of the surfaces is kept constant and (2) variations of the total area of the vertical tail surface. A report has been published (reference 1) on the flying qualities of the airplane with the original tail surfaces. The present report compares the results obtained from tests of the handling qualities of the airplane with the first set of modified tail surfaces to the handling qualities with the original tail. Only those handling qualities affected by the modification of the tail are considered. For convenience in this and subsequent papers, the original tail surfaces of reference 1 are hereafter called tail configuration number one. All tests were made at the Langley Memorial Aeronautical Laboratory between October 1941 and May 1942.

TAIL-SURFACE MODIFICATIONS

The second tail configuration differed from the first in that the horn balances were removed so that the rudder and elevator were no longer aerodynamically balanced. The modified control surfaces were mass balanced by means of lead weights mounted on the

forward end of loops which passed through cut-outs in the fixed surfaces. The areas of tail configuration number two follow:

Fin area (above fuselage, ahead of hinge line), sq ft	12.4
Rudder area (behind hinge line), sq ft	13.6
Rudder trimming-tab area, sq ft	0.9
Stabilizer area (ahead of hinge line, including contained fuselage area), sq ft	33.3
Elevator area (behind hinge line), sq ft	27.9
Elevator trimming-tab area (not changed), sq ft	1.7

On tail configuration number one, the rudder horn-balance area was 1.5 square feet and the elevator horn-balance area was 2.7 square feet. There was no trimming tab on the rudder.

Drawings of the tail surfaces are given in figures 5 through 8.

The relation between control-stick position and elevator deflection is shown in figure 9.

A description of the airplane is given in reference 1.

AIRSPEED CALIBRATION

The airspeed recorder used for these tests was calibrated by the use of a trailing airspeed bomb.

TESTS, RESULTS, AND DISCUSSION

All of the measurements of flying qualities were made with the center of gravity located at 25.5 percent of the mean aerodynamic chord with full service load. In this condition the airplane weighed 5770 pounds or the wing loading was 22.4 pounds per square foot. Retracting the landing gear had no effect on the horizontal location of the center of gravity and the effect of fuel consumption on the center-of-gravity position was sufficiently small to be ignored.

LONGITUDINAL STABILITY AND CONTROL

Characteristics of uncontrolled longitudinal motion.-

The degree of damping of the short-period oscillation was determined by deflecting the elevator and quickly releasing it in high-speed flight. With both tail configurations, the subsequent variation of normal acceleration and elevator angle had completely disappeared after one cycle. This satisfied the requirement stated in reference 2.

The long-period (phugoid) oscillation was not investigated.

Characteristics of elevator control in steady flight.-

The characteristics of the elevator control of the XSBA-1 airplane in steady flight were measured by recording the elevator positions and forces required for trim at various airspeeds and trimming-tab settings. These measurements were made in the following conditions of flight:

Flight condition	Manifold pressure at 6000 ft (in. Hg)	Propeller speed (rpm)	Flap position	Landing-gear position
Cruising	25	1800	Up	Up
Climbing	32	1800	Up	Up
Gliding	Throttle closed	-----	Up	Up
Landing	Throttle closed	-----	Down	Down
Approach	18	1900	Half down	Down
Wave-off	34	2100	Down	Down

Conclusions reached regarding the elevator control characteristics may be summarized as follows:

1. In all of the conditions of flight, at low speeds, stick-fixed static stability existed for the airplane with tail configuration number two as shown by the negative slopes of the curves of elevator angle against airspeed in figures 10 through 13. The stability was greatest in the landing and gliding conditions, less in the cruising and climbing conditions, small in the approach condition, and just above neutral

in the wave-off condition. At higher speeds the stability became approximately neutral in the flaps-up conditions. Figure 14 also gives an indication of the stick-fixed static stability in the gliding, cruising, and climbing conditions of flight showing neutral stability in the climbing condition at low angles of attack.

Comparison with the results given for the airplane with tail configuration number one in reference 1 showed little difference in the stick-fixed static stability as obtained with the two tail configurations. Since the elevator area was changed only slightly by removal of the horn balance, no appreciable change in stick-fixed stability was to be expected. However, with the first tail configuration the airplane was slightly stable in any condition at the upper end of the speed range.

2. For the airplane with tail configuration number two, the slope of the curves of stick force against airspeed, also figures 10 through 13, is negative at the speed at which the airplane was trimmed in the gliding, cruising, climbing, and landing conditions. This characteristic assures stick-free static stability of the airplane in the gliding and landing conditions. However, the slopes of the curves of stick force against airspeed for the cruising and climbing conditions reversed between 90 and 130 miles per hour so that, although the airplane was stable stick free for trim speeds near 200 miles per hour, the stability would have been neutral or slightly negative for trim speeds below approximately 140 miles per hour. In the approach and wave-off conditions with the second tail configuration, the slope of the curves of stick force against airspeed is about zero. Since on the XSBA-1 airplane the force change produced by the trimming-tab increases with airspeed, it is believed that the airplane would have been unstable if trimmed to zero stick force in the wave-off condition.

With tail configuration number one, the curves of stick force against airspeed for the cruising, climbing, and gliding conditions were on the verge of reversing between 90 and 130 miles per hour. The characteristic shape of the curves of force variation for several flight conditions with either tail configuration is believed to have been caused by nonlinear hinge-moment

properties of the elevator and by the influence of the wing wake at the tail.

A summary of the stick-free static-stability characteristics with the two sets of tail surfaces follows:

Condition	Tail configuration number one	Tail configuration number two
Cruising	Stable	Neutral
Climbing	-----do.-----	Do.
Gliding	-----do.-----	Stable
Approach	-----do.-----	Neutral
Landing	-----do.-----	Stable
Wave-off	-----do.-----	Unstable

3. For the airplane with tail configuration number two, the elevator control force was sufficiently large compared to the friction to return the control to its trim position in the gliding and landing conditions. In the other conditions the elevator control-force gradient was about zero for part or all of the speed range for some trim speeds. Therefore, in the cruising, climbing, wave-off, and approach conditions, the airplane with tail number two did not meet the requirements of reference 2. With the first tail configuration, it was possible to trim in all conditions.

4. With either tail configuration, the elevator angles required for trim were well within the available range in all conditions tested.

Characteristics of elevator control in accelerated flight.— The characteristics of the elevator control in accelerated flight were determined from measurements taken in abrupt pull-ups and push-downs from level flight and in rapid 180° turns. The results of the pull-ups and push-downs with tail configuration number two are presented in figures 15 and 16. Time histories of representative turns are presented in figures 17 through 20. Figure 22 shows the variation of elevator angle with lift coefficient in 180° turns. The results of the tests pertaining to elevator control in accelerated flight may be summarized as follows:

1. For the airplane with either tail configuration, the elevator control was sufficiently powerful to develop either the maximum lift coefficient or the allowable load factor at every airspeed. This fact was evident in pull-ups made at various airspeeds.

2. With both tails the normal acceleration was observed to increase progressively with elevator angle at any given airspeed.

3. Stick motion of 4.6 inches from the trim position produced a stall with tail configuration number one. No records of a stall in a turn were obtained with the second tail configuration, but figure 18 is a time history of a turn in which a normal acceleration of 4g was reached which required an elevator deflection of 11° from the trim position. This corresponds to a stick travel of 4.3 inches and hence meets the requirement of reference 2.

4. The variation of stick force with normal acceleration in 180° turns with tail configuration number two is plotted in figure 21. Change in normal acceleration was proportional to the elevator control force applied with either tail.

5. An average force of about 30 pounds per g was required to make a highly accelerated turn with tail configuration number one. This was reduced to 27 pounds per g with the second tail configuration. However, the force per g was excessive in either case as about 15 pounds per g is a reasonable limit of stick-force gradient for a scout bomber such as the XSBA-1 airplane.

Characteristics of elevator control in landing.-
With both elevators the same up-elevator deflection and the same force was required to land. The elevator control was sufficiently powerful to hold the airplane off the ground until three-point contact was made. The average of records taken of several landings showed that 21° of up-elevator deflection was required to make a three-point landing. This was the same as the amount of up-elevator deflection required to stall. Usually about 10° more elevator deflection is required to land a low-wing airplane than to stall it in the landing condition at altitude. For the XSBA-1 airplane, it is believed that the separation of the flow from the wing root in a stall reduced the downwash at the tail as the stall was approached, just as the ground effect reduces

the downwash at the tail when the airplane is landing.

The elevator control force required to make a landing was about 41 pounds with either tail. This exceeds by 6 pounds the upper limit recommended in reference 2.

Characteristic of elevator control in take-off.-
With either tail the elevator was adequate to adjust the attitude angle as desired during take-off.

Trim changes due to power and flaps.- The trim change caused by lowering the flaps was in the direction tending to cause the airplane to nose up. Lowering the landing gear caused the airplane to nose down. A push force of 18 pounds with tail configuration number one or 9 pounds with tail configuration number two was required to maintain trim if the flaps and landing gear were lowered with the power off at 120 miles per hour. This trim change is in the opposite direction to that usually considered desirable. Application of power with flaps and landing gear up produced a slight nosing-up tendency. With flaps and landing gear down, this tendency was increased so that a push force of 18 pounds with tail configuration number one, but only 10 pounds with tail number two, was required to maintain trim at 120 miles per hour. The stick-force change at this speed in going from the flaps-up power-off condition to the flaps-down full-power condition was about 38 pounds with configuration number one, which exceeds the upper limit of 35 pounds recommended in reference 2, but was only 20 pounds with configuration number two.

Characteristics of longitudinal trimming device.-
The trimming-tab setting required in the various flight conditions to trim at zero stick force with tail configuration number two is plotted in figures 10 through 13. With either tail configuration the trimming tabs were sufficiently powerful to reduce the stick force to zero at any point in the speed range in the power-on conditions of flight. In the power-off conditions, the airplane could be trimmed at all speeds in the range more than 10 miles per hour above the stall with the number one tail. Due to the decreased travel of the tab on the number two elevator, the minimum speed for trim was about 20 miles per hour above the stall

in the landing and gliding conditions. Unless changed manually, the trimming tabs in both the elevators retained a given setting indefinitely.

LATERAL STABILITY AND CONTROL

Characteristics of uncontrolled lateral and directional motion.- The control-free lateral oscillation with tail configuration number two damped to one-half amplitude in about one-half cycle, as shown in figure 23, satisfying the requirement of reference 2. The rate of damping decreased very slightly with speed. With tail configuration number one, the number of cycles required to damp to one-half amplitude increased from one-half to one and one-half with airspeed. The period of the oscillation was half again as long with the second tail configuration as with the first. The relation of yaw angle to rudder angle showed that rudder number two floated with the relative wind and that rudder number one floated against the relative wind, as would be expected with a horn balance. This explains why the period of lateral oscillation was longer and the damping more rapid with tail configuration number two.

Rudder control characteristics.- The rudder control characteristics were measured in steady flight, in sideslips, and in abrupt rudder kicks. In the rudder-kick maneuvers, records were taken of rudder position, rudder force, rolling velocity, sideslip angle, and normal acceleration resulting from abrupt deflections of the rudder in steady flight while the other controls were held fixed. The results of the sideslips are shown in figures 24 through 31. The results of the rudder kicks are shown in figures 32 through 34.

The results may be summarized as follows:

1. Both rudder number one and rudder number two were powerful enough to overcome the adverse aileron yawing moment in all conditions tested.
2. Either rudder was sufficiently powerful to maintain directional control during take-off and landing.
3. Figure 35 shows that rudder number two was sufficiently powerful to trim the airplane at all airspeeds

above the minimum for each condition tested. Rudder number one also satisfied this requirement.

4. The effectiveness of the rudder in recovery from spins was not investigated.

5. The rudder control force was proportional to rudder deflection with either tail configuration. Right-rudder force was required to hold right-rudder deflections and left-rudder force, to hold left-rudder deflections.

6. Rudder number two was about 25 percent lighter than rudder number one in sideslips. With either rudder, the force required to overcome the yawing moment due to full aileron deflection was about 100 pounds. The trim changes caused by decreasing airspeed were not excessive. Complete data were not obtained, but the largest recorded trimming force was 75 pounds for rudder number two in the wave-off condition at 56 miles per hour. In all cases, with either rudder, the forces required were below the 180 pound limit recommended in reference 2.

Yawing moment due to sideslip.- Characteristics of the yawing moment due to sideslip were found to be as follows:

1. With rudder locked, at 110 percent of the minimum speed the maximum change in sideslip angle developed as a result of full aileron deflection was about 20° , which is the maximum allowable under the requirement of reference 2.

2. With either rudder, the yawing moment due to sideslip was such that the rudder movement required was in the correct direction from the trim position; that is, right rudder produced left sideslip and left rudder produced right sideslip. For angles of sideslip between $\pm 15^{\circ}$, the angle of sideslip was substantially proportional to rudder deflection for either rudder.

3. The yawing moment due to sideslip (rudder free) with either tail configuration was such that the airplane always tended to return to the trim condition regardless of the angle of sideslip to which it was forced.

Pitching moment due to sideslip.- With both the number one and the number two tails, the curves of elevator angle against angle of sideslip show that the

pitching moment due to sideslip was small. A maximum of $1\frac{1}{2}^{\circ}$ of up-elevator deflection was required to maintain longitudinal trim for steady sideslip produced by 5° of rudder deflection. It should be noted in interpreting the curves of angle of sideslip for a given airspeed that there may be some error in the indicated airspeed due to the angle of yaw of the pitot static head which was only permitted to swivel vertically.

Power of rudder trimming device.- There was no trimming tab on the number one rudder. The trimming tab on the number two rudder was sufficiently powerful to reduce the rudder forces to zero in all conditions of level flight. Unless changed manually, the trimming tab would retain a given setting indefinitely.

CONCLUSIONS

The comparison of the handling qualities of the Brewster XSBA-1 airplane with tail configurations number one and number two may be summarized as follows:

1. The XSBA-1 airplane with tail configuration number two had stick-fixed static longitudinal stability in all conditions at low speeds and approached neutral stability at higher speeds except in the landing and approach conditions of flight. Tail configuration number one produced stick-fixed stability in all conditions throughout the speed range. The stability was not large at higher speeds.

2. The airplane with the second tail configuration had stick-free static longitudinal stability in the gliding and landing conditions. The stability was neutral in the cruising, climbing, and approach conditions and slightly negative in the wave-off condition. With the first tail configuration, stick-free static longitudinal stability existed in all conditions and, in the approach and wave-off conditions, the curves of elevator control force against indicated airspeed had a steep negative slope.

3. Tail configuration number two reduced the average elevator control-force gradient from 30 to

27 pounds per g. This value still far exceeds the maximum gradient of 15 pounds per g that is considered reasonable for scout bombers.

4. The stick travel required to stall in maneuvers was desirably large. It was about 4.6 inches with tail configuration number one and approximately the same with tail configuration number two.

5. With the first tail configuration, trim changes caused by application of power or lowering the flaps were large and caused a nosing-up tendency. With tail configuration number two, these trim changes were reduced about 50 percent. The stick-force change at 120 miles per hour in going from the flaps-up power-off condition to the flaps-down full-power condition was 38 pounds with the tail configuration number one but was reduced to 20 pounds with tail configuration number two, which was well below the recommended maximum of 35 pounds.

6. With either tail the directional stability was sufficiently large to limit the yaw caused by full deflection of the ailerons with the rudder fixed to 20° at low flying speeds. The pitching moment due to sideslip was desirably small in all flight conditions.

7. The rudder control with either rudder was sufficiently effective to maintain straight flight at minimum speed in all flight conditions. Either rudder was powerful enough to overcome aileron yaw in all conditions. The rudder forces were approximately the same with either

rudder and did not exceed the limit recommended by reference 2. However, rudder number two was about 25 percent lighter than rudder number one in sideslips.

Langley Memorial Aeronautical Laboratory,
National Advisory Committee for Aeronautics,
Langley Field, Va., December 2, 1943.

REFERENCES

1. Phillips, W. H., and Nissen, J. M.: Flight Tests of Various Tail Modifications on the Brewster XSBA-1 Airplane. I - Measurements of Flying Qualities with Original Tail Surfaces. NACA ARR No. 3F07, 1943.
2. Gilruth, R. R.: Requirements for Satisfactory Flying Qualities of Airplanes. NACA A.C.R., April 1941.

L-598

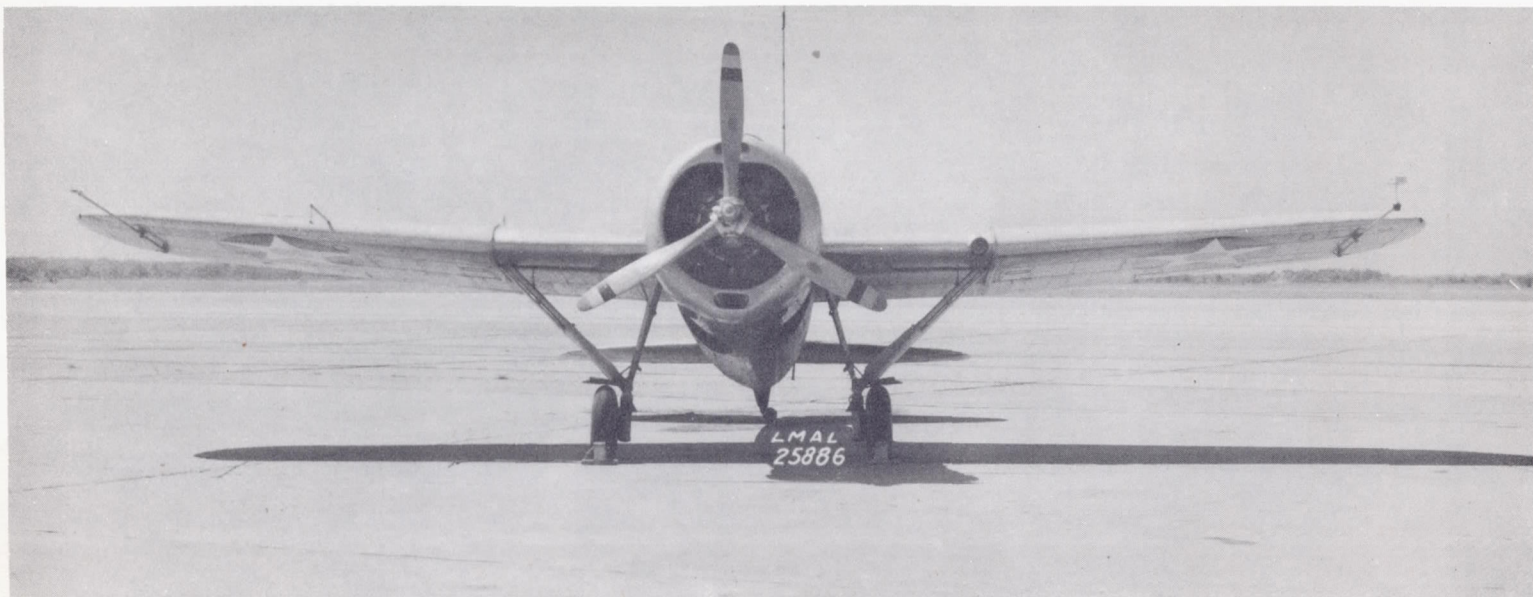

Figure 1.- Front view of Brewster XSBA-1 airplane.



Figure 2.- Three-quarter front view of Brewster XSBA-1 airplane.

NATIONAL ADVISORY COMMITTEE FOR AERONAUTICS
LANGLEY MEMORIAL AERONAUTICAL LABORATORY - LANGLEY FIELD, VA.

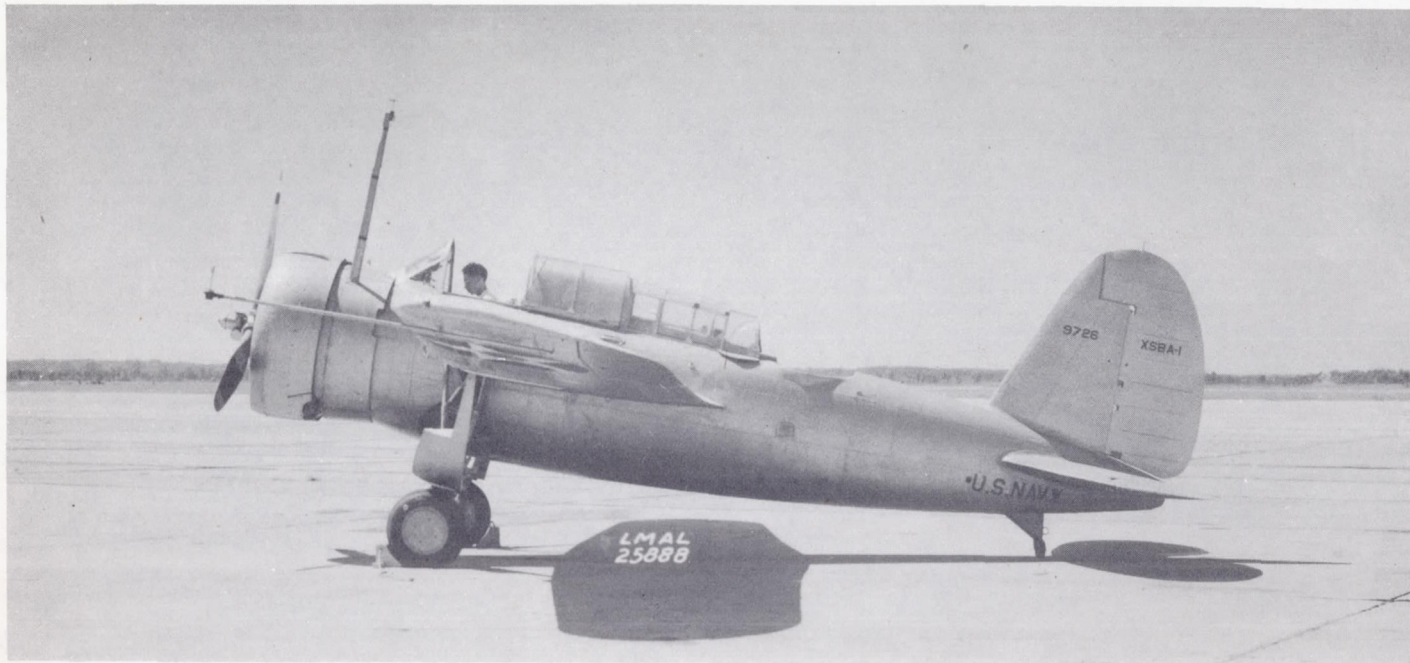

Figure 3.- Side view of Brewster XSBA-1 airplane showing vertical tail configuration number one.

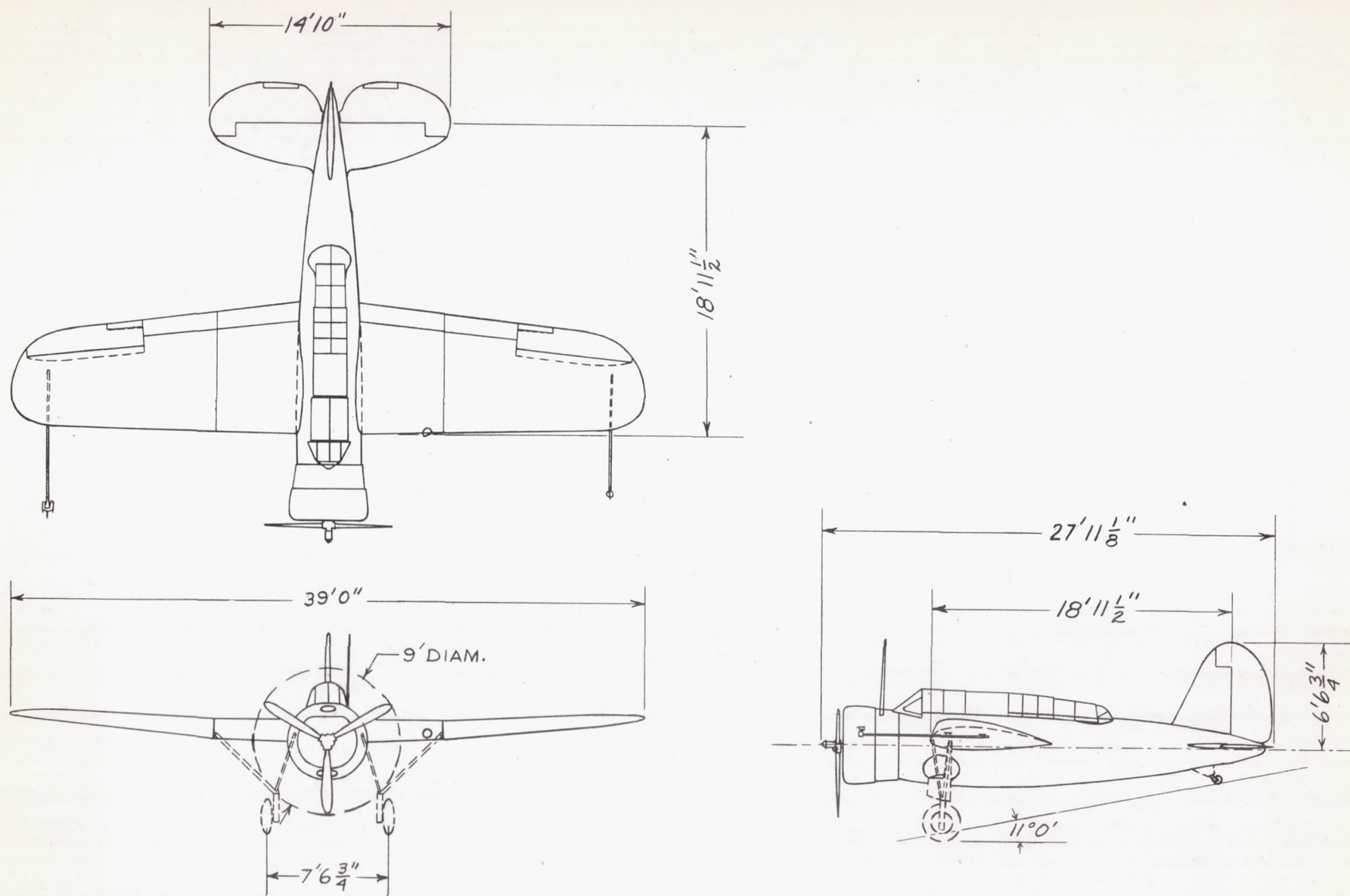

Figure 4.- Three-view drawing of Brewster XSBA-1 airplane showing tail configuration number one.

NATIONAL ADVISORY
COMMITTEE FOR AERONAUTICS.

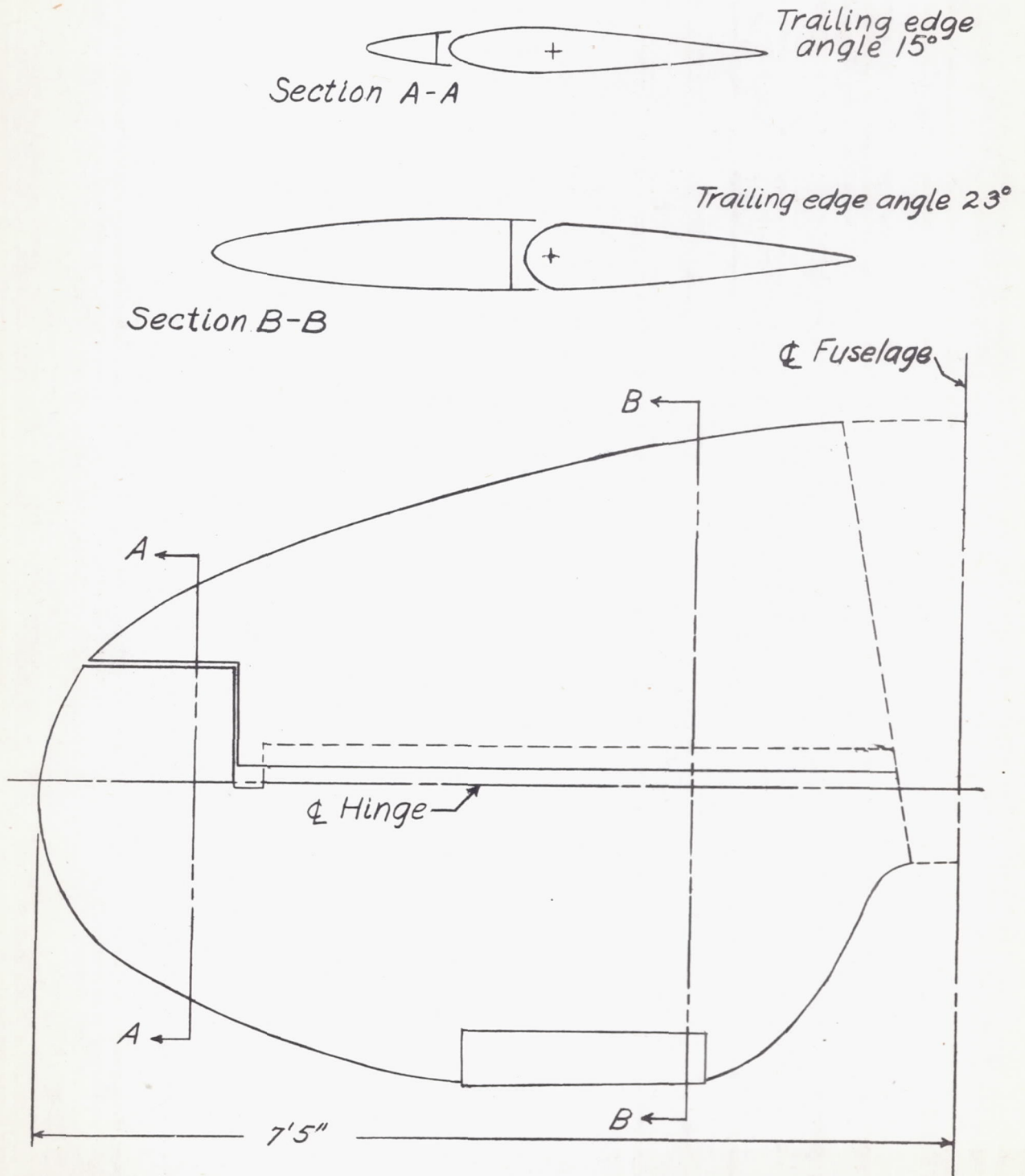
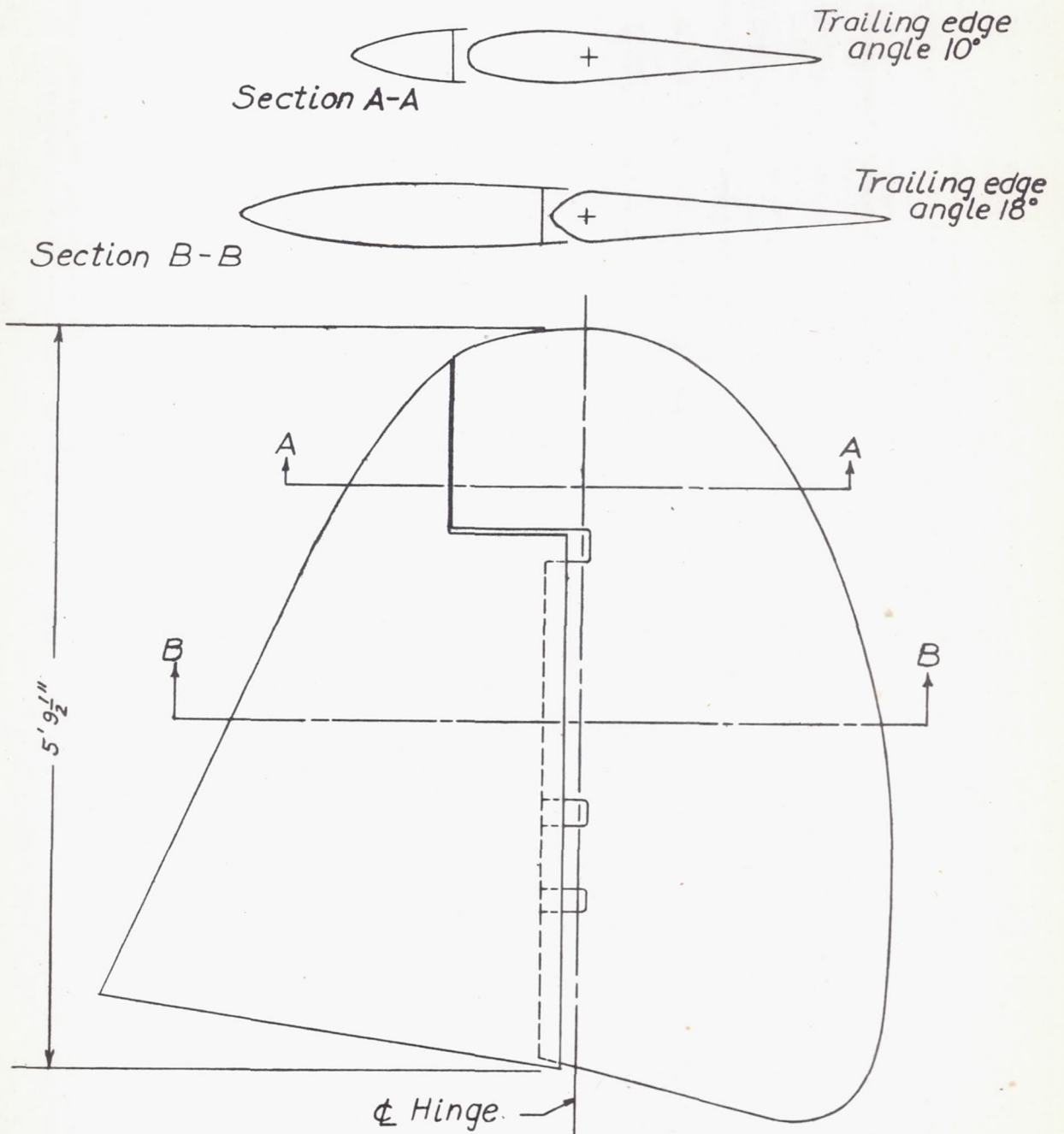

Figure 5.- Horizontal tail configuration number one. Brewster XSBA-1 airplane.



NATIONAL ADVISORY
COMMITTEE FOR AERONAUTICS

Figure 6.- Vertical tail configuration number one. Brewster XSBA-1 airplane.

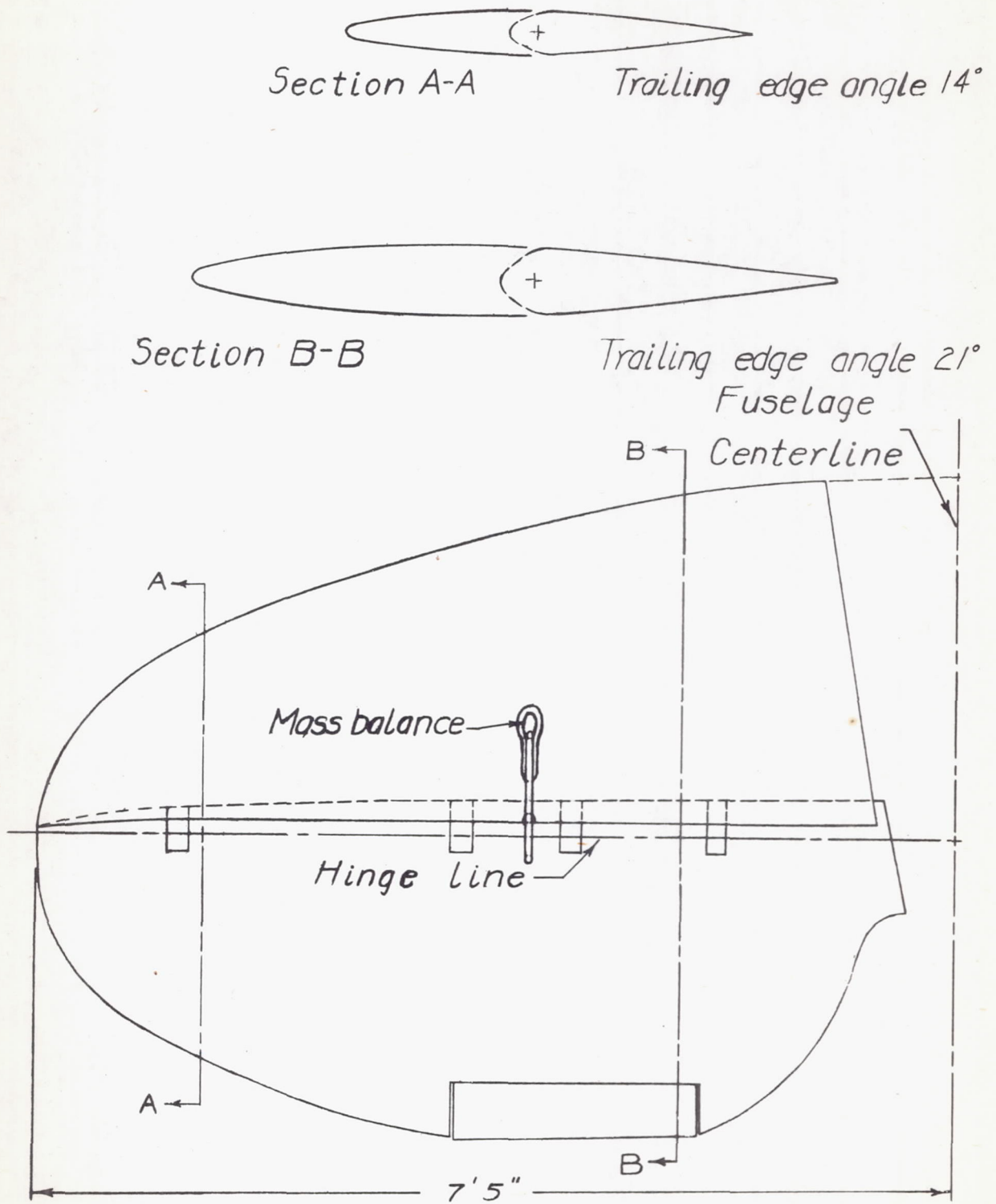
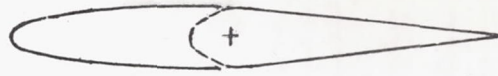
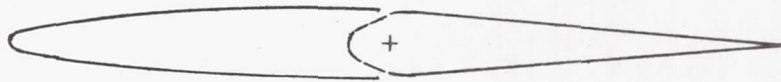

Figure 7.- Horizontal tail configuration number two. Brewster XSBA-1 airplane.



Section A-A

Trailing edge angle 9°



Section B-B

Trailing edge angle $8\frac{1}{2}^\circ$

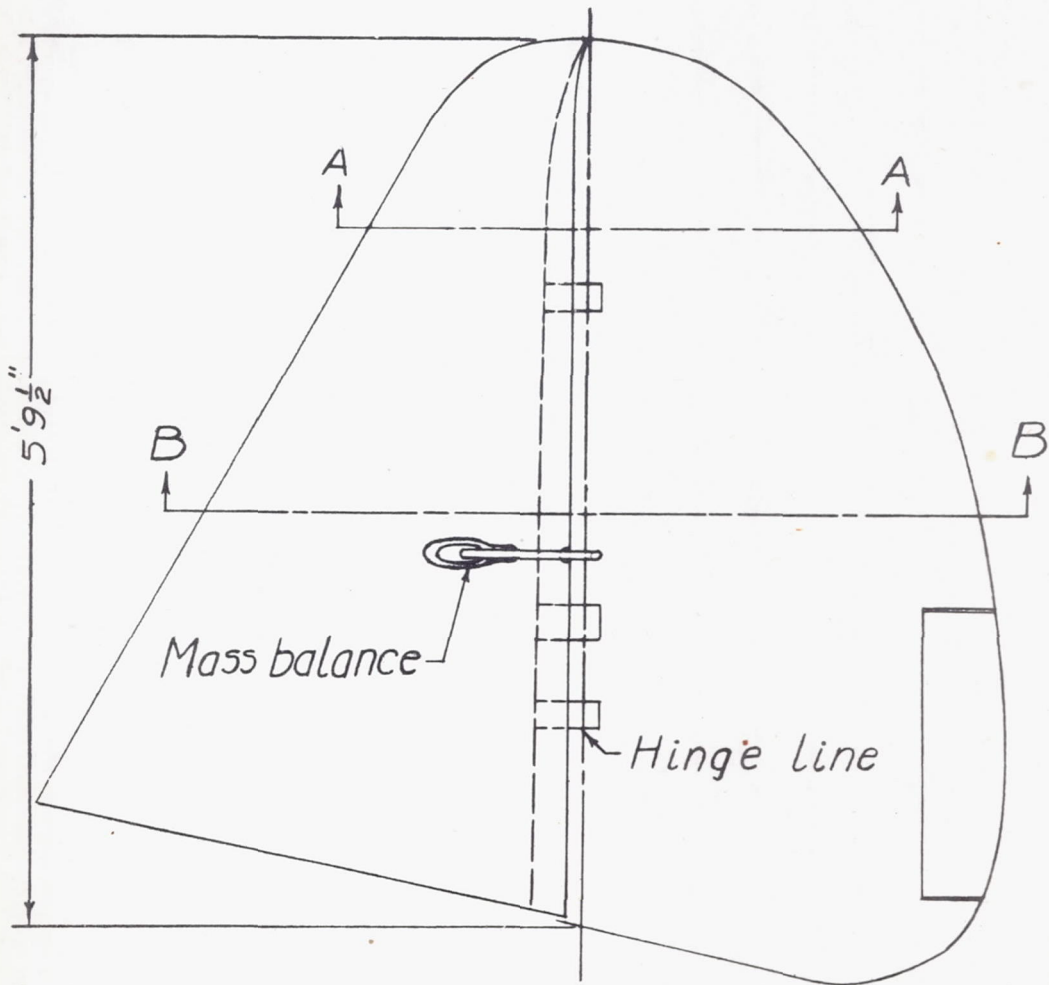

NATIONAL ADVISORY
COMMITTEE FOR AERONAUTICS

Figure 8.- Vertical tail configuration number two. Brewster XSBA-1 airplane.

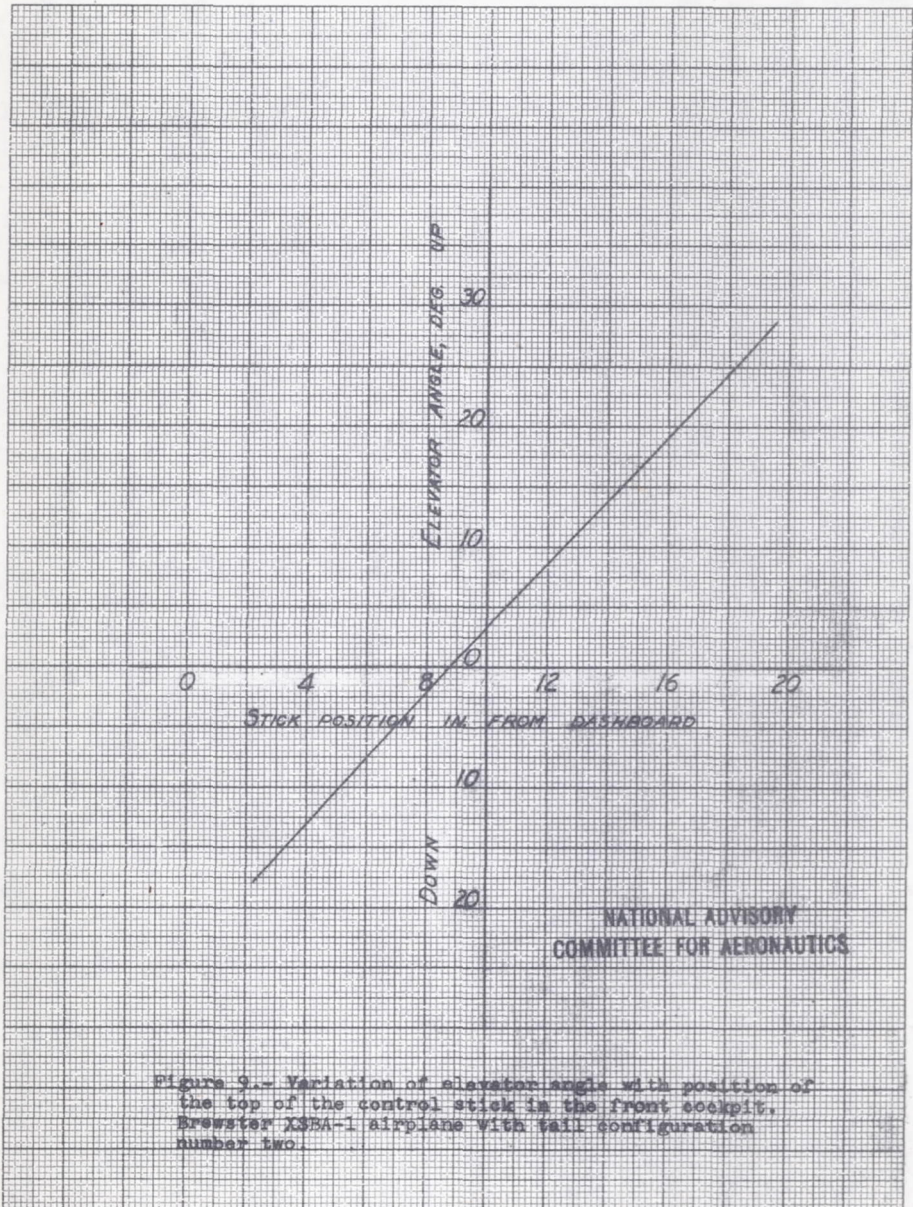
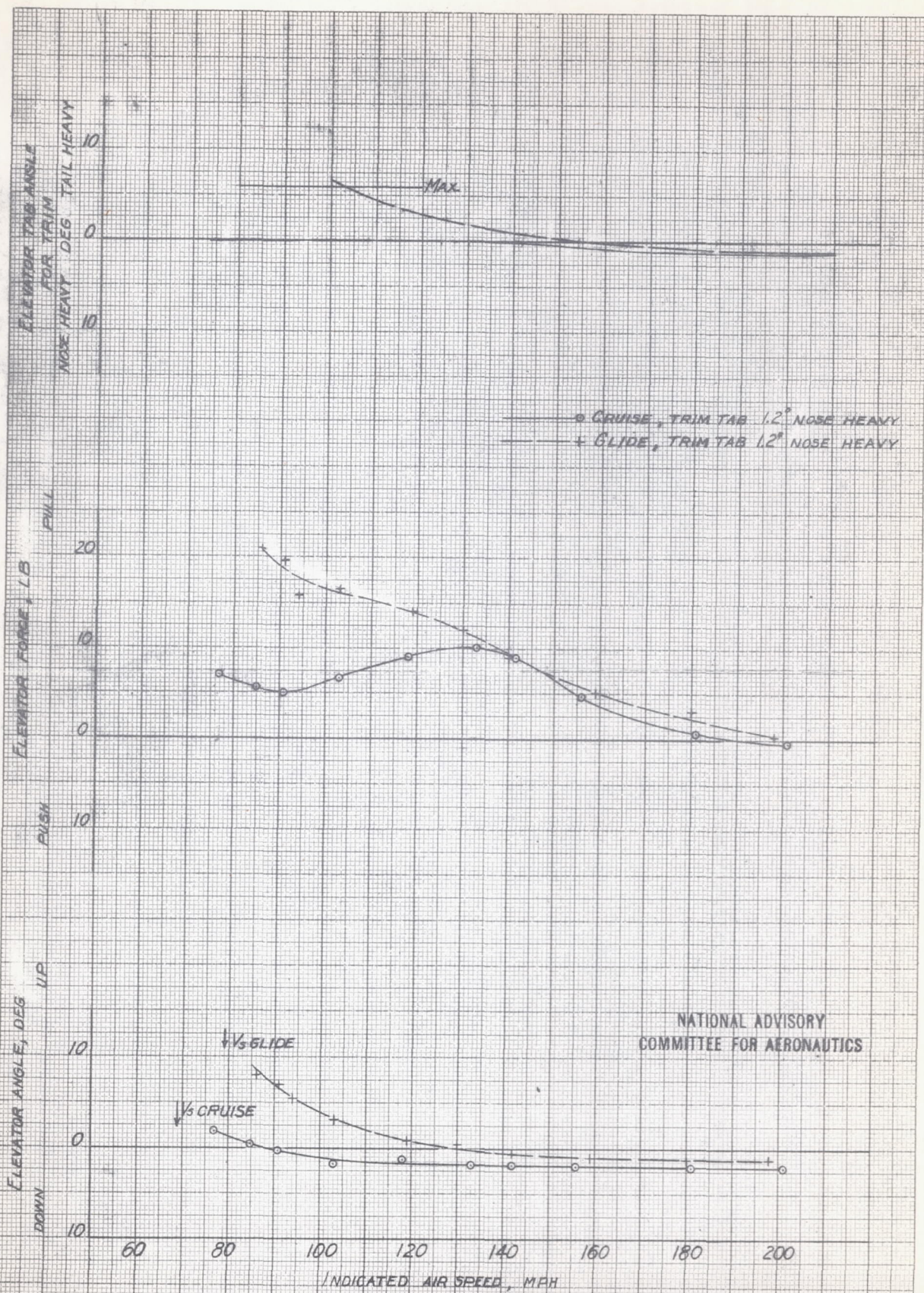

Figure 9.- Variation of elevator angle with position of the top of the control stick in the front cockpit, Brewster XSEA-1 airplane with tail configuration number two.



NATIONAL ADVISORY
COMMITTEE FOR AERONAUTICS

Figure 10.- Variation of elevator angle, elevator force, and elevator tab angle required for trim with indicated airspeed in the gliding and cruising condition. Brewster XSBA-1 airplane with tail configuration number two.

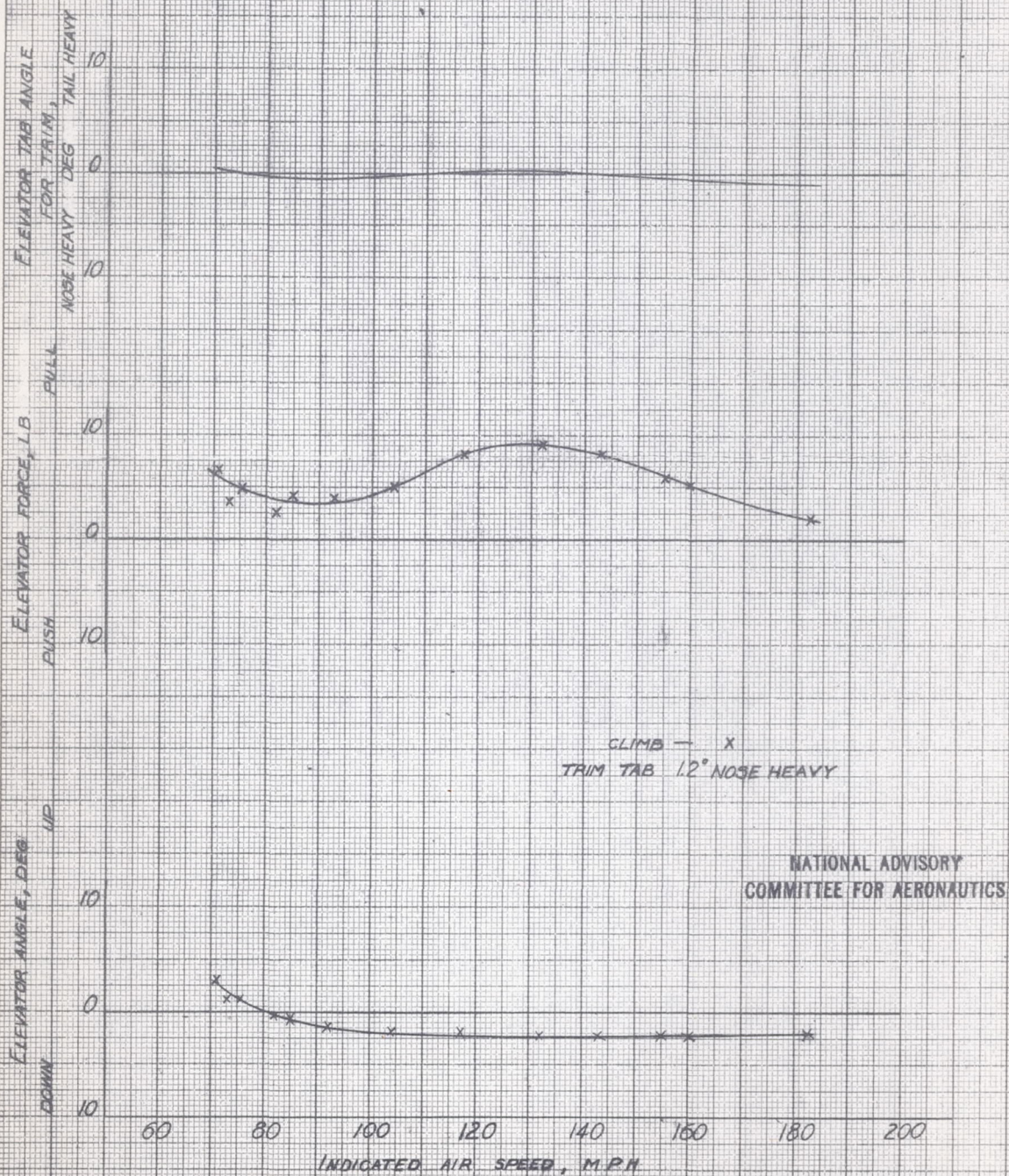

Figure 11.- Variation of elevator angle, elevator force, and elevator tab angle required for trim with indicated airspeed in the climbing condition. Brewster XSBA-1 airplane with tail configuration number two.

NATIONAL ADVISORY
COMMITTEE FOR AERONAUTICS

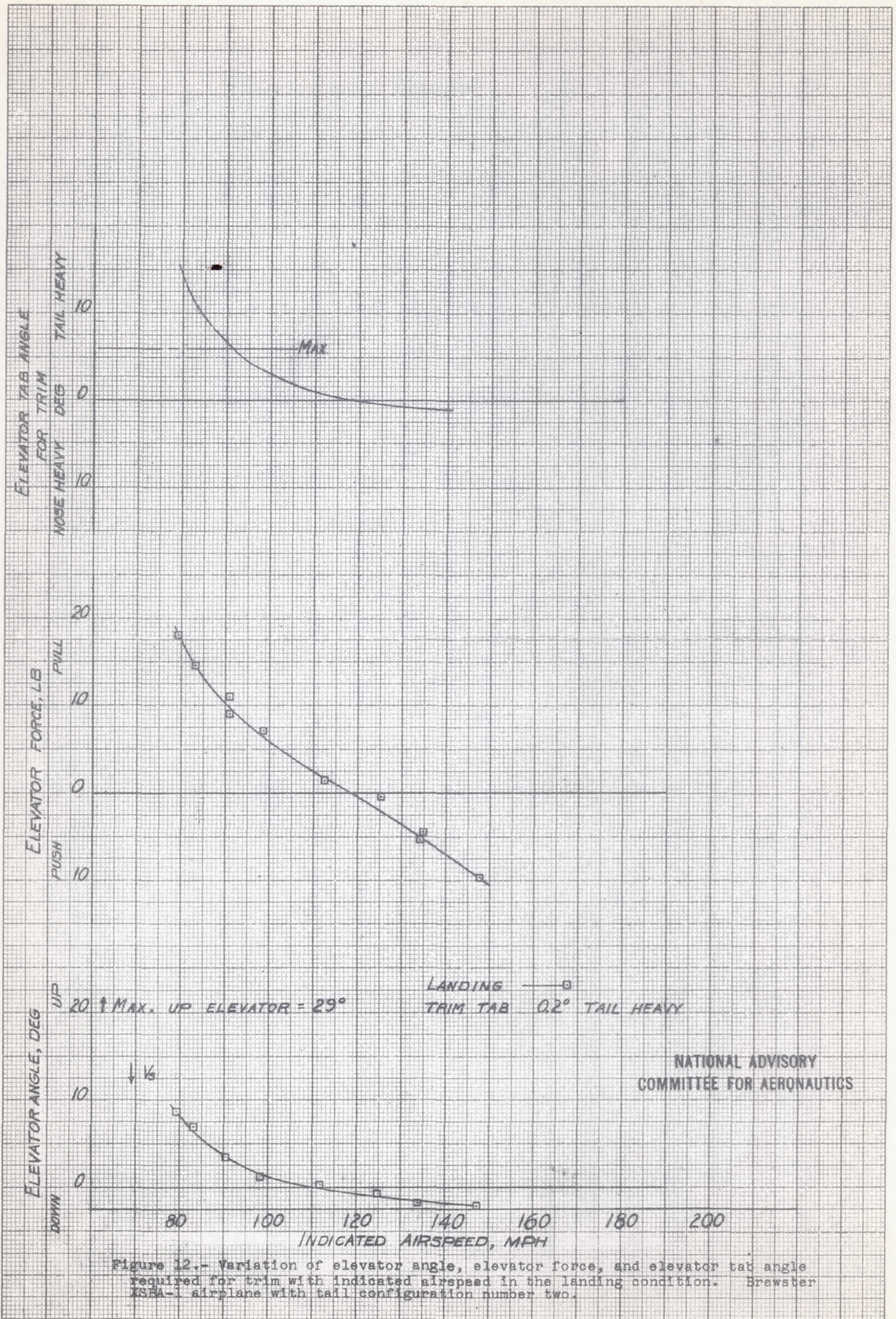

Figure 12.- Variation of elevator angle, elevator force, and elevator tab angle required for trim with indicated airspeed in the landing condition. Brewster XSB-1 airplane with tail configuration number two.

NATIONAL ADVISORY
COMMITTEE FOR AERONAUTICS

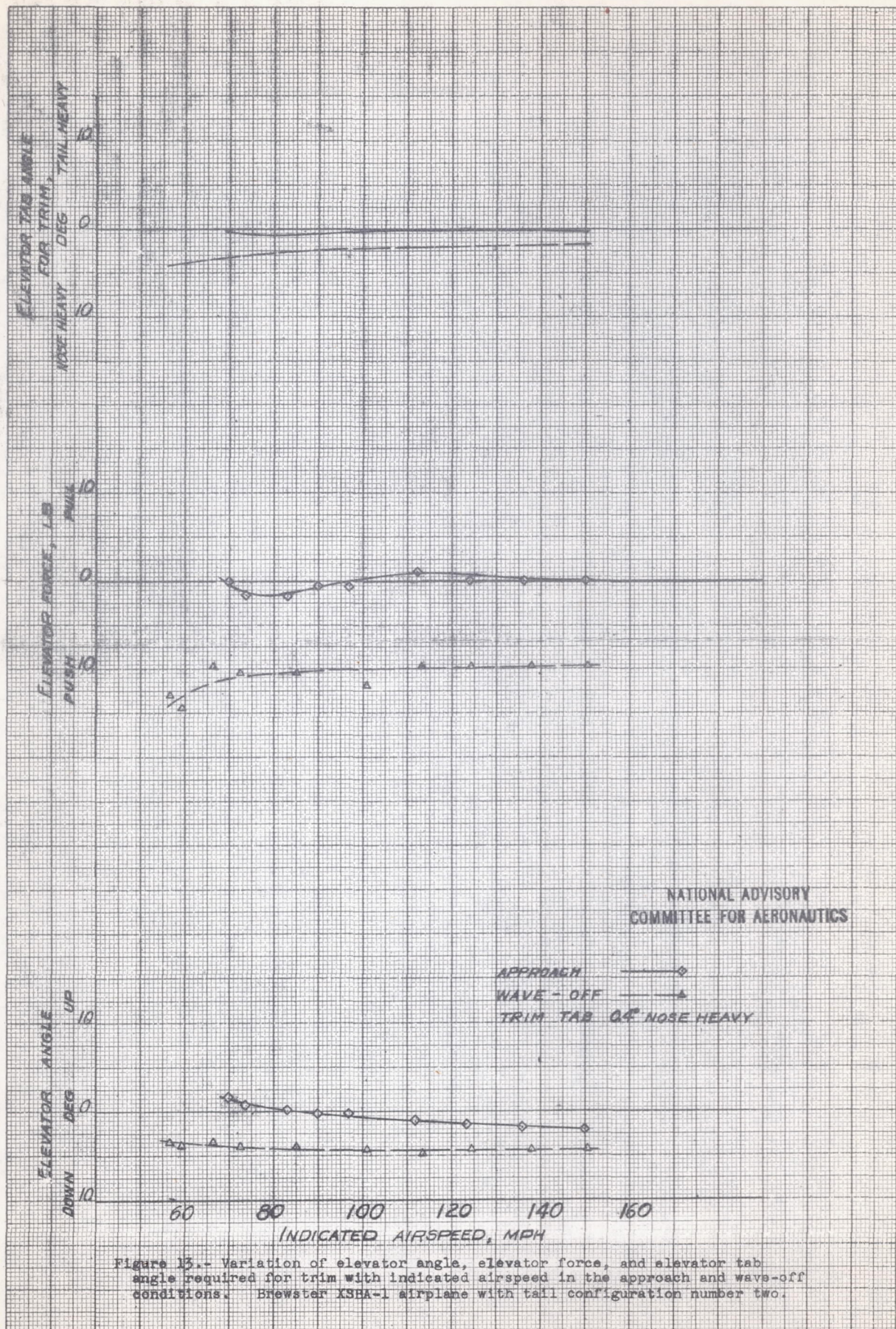

Figure 13.- Variation of elevator angle, elevator force, and elevator tab angle required for trim with indicated airspeed in the approach and wave-off conditions. Brewster X3BA-1 airplane with tail configuration number two.

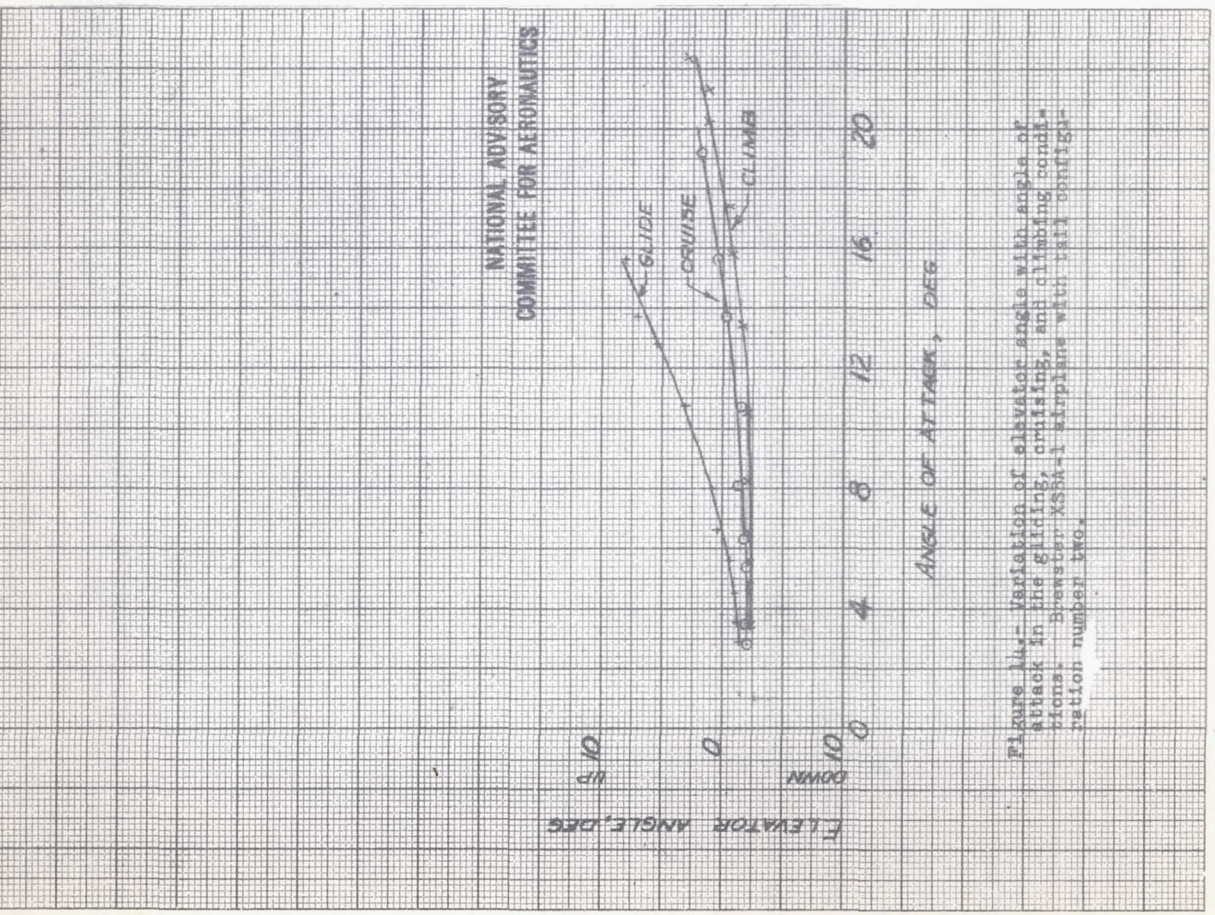

Figure 14.- Variation of elevator angle with angle of attack in the gliding, cruising, and climbing conditions. Brewster XSB-1 airplane with tail configuration number two.

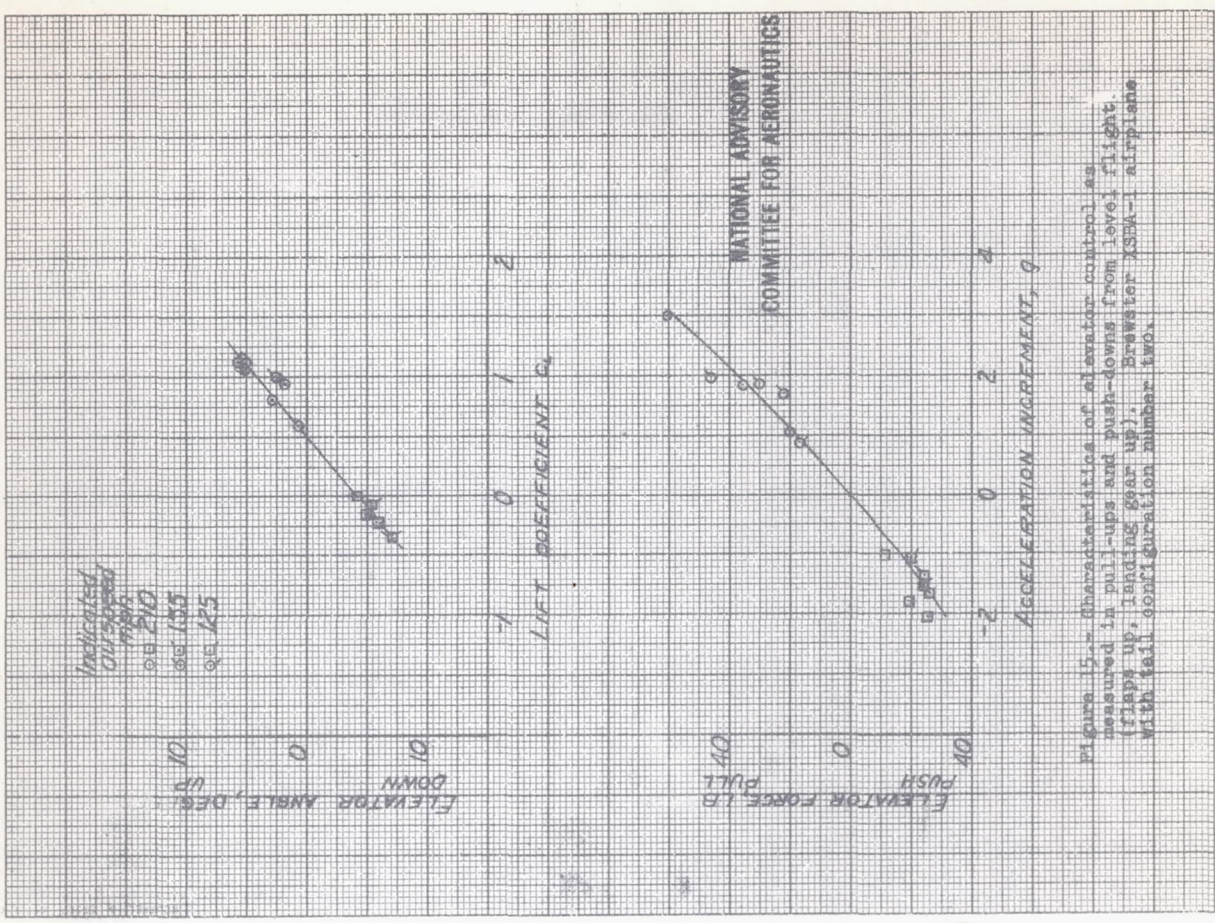

Figure 15.- Characteristics of elevator control as measured in pull-ups and push-downs from level flight (flap up, landing gear up). Brewster XSB-1 airplane with tail configuration number two.

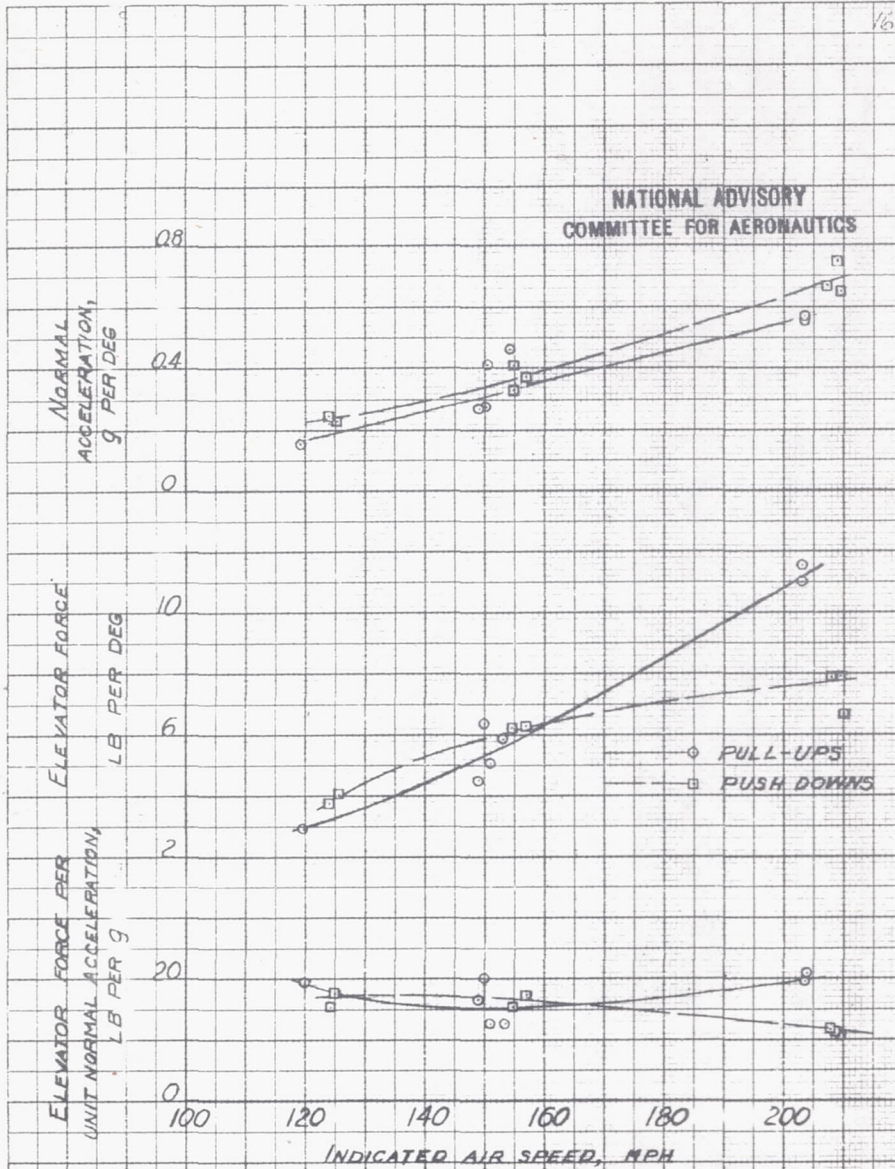

Figure 16.- Variation of characteristics of elevator control with indicated airspeed as measured in pull-ups and push-downs from level flight (flaps up, landing gear up). Brewster XSB-1 airplane with tail configuration number two.

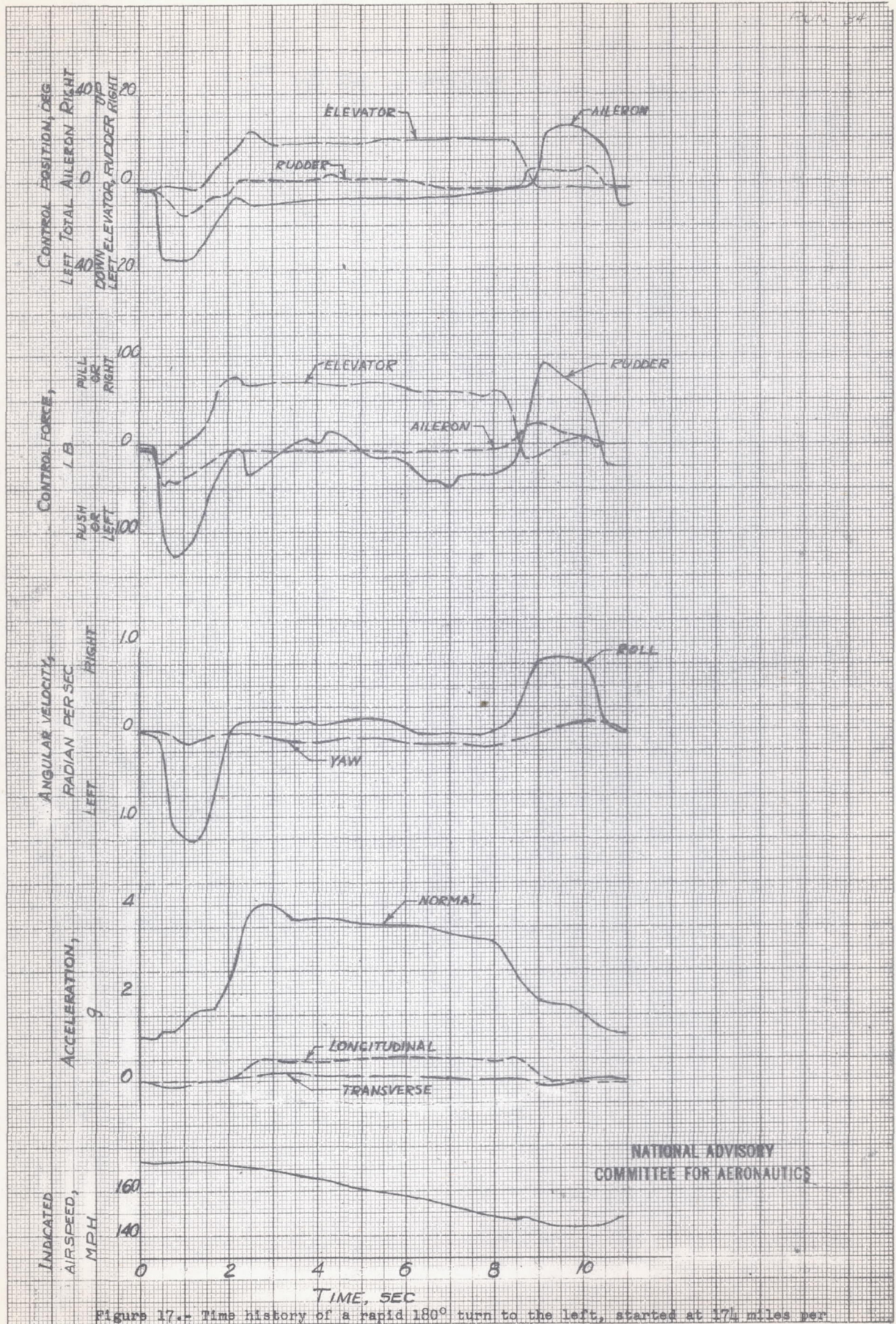
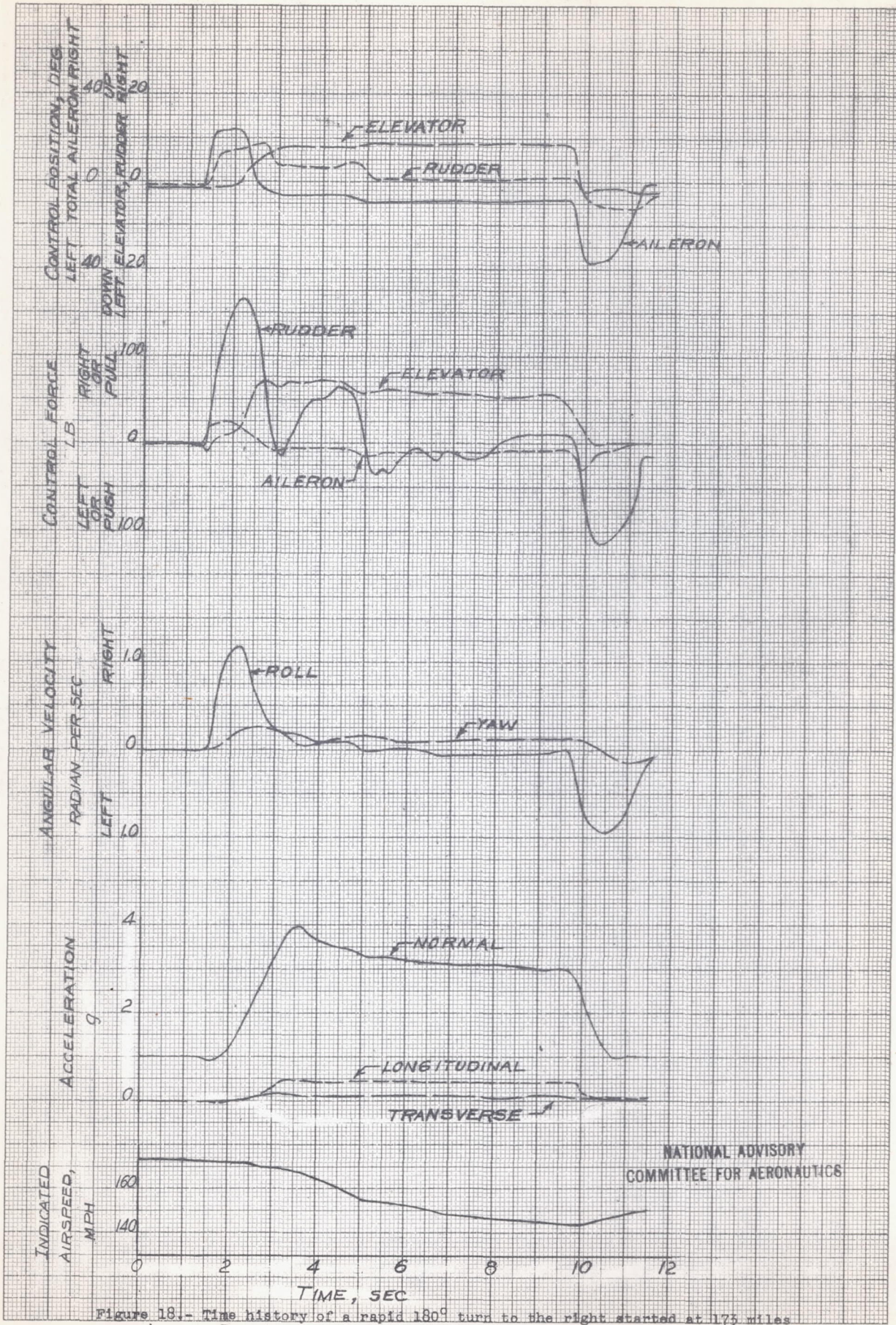
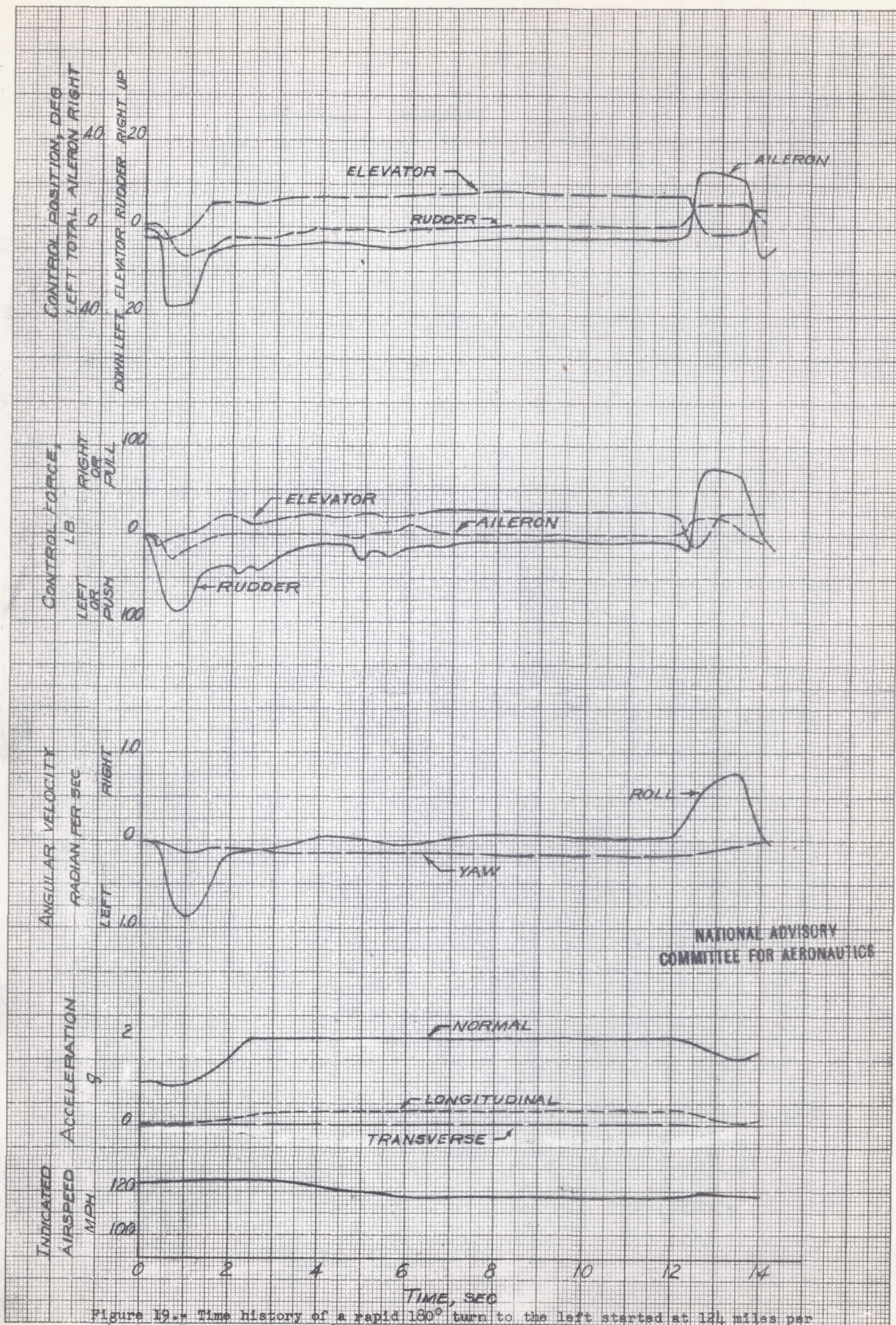

Figure 17.- Time history of a rapid 180° turn to the left, started at 174 miles per hour. Brewster XSBA-1 airplane with tail configuration number two.



NATIONAL ADVISORY
COMMITTEE FOR AERONAUTICS

Figure 18.- Time history of a rapid 180° turn to the right started at 173 miles per hour. Brewster XSBA-1 airplane with tail configuration number two.



NATIONAL ADVISORY
COMMITTEE FOR AERONAUTICS

Figure 19.- Time history of a rapid 180° turn to the left started at 124 miles per hour. Brewster XSBA-1 airplane with tail configuration number two.

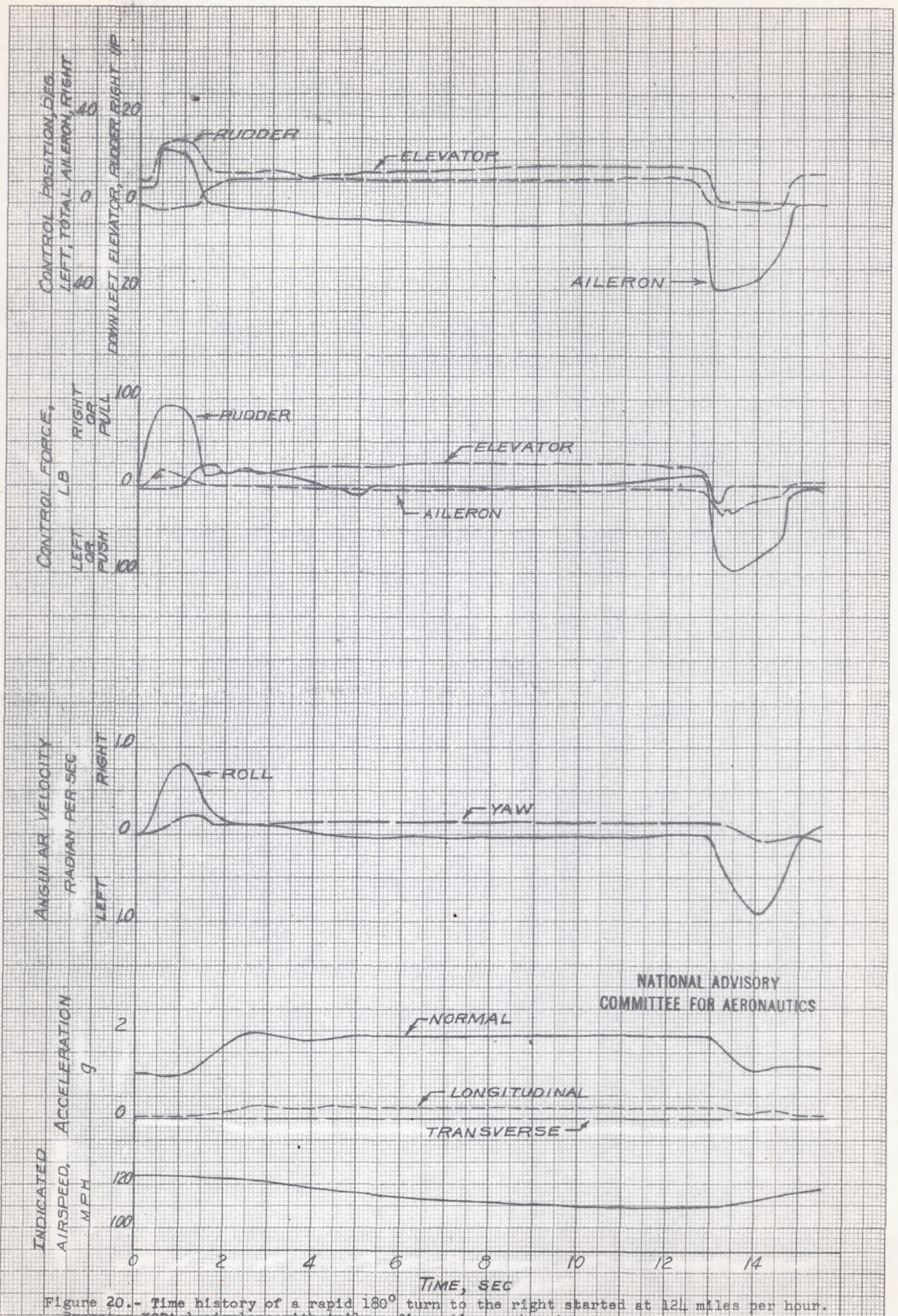
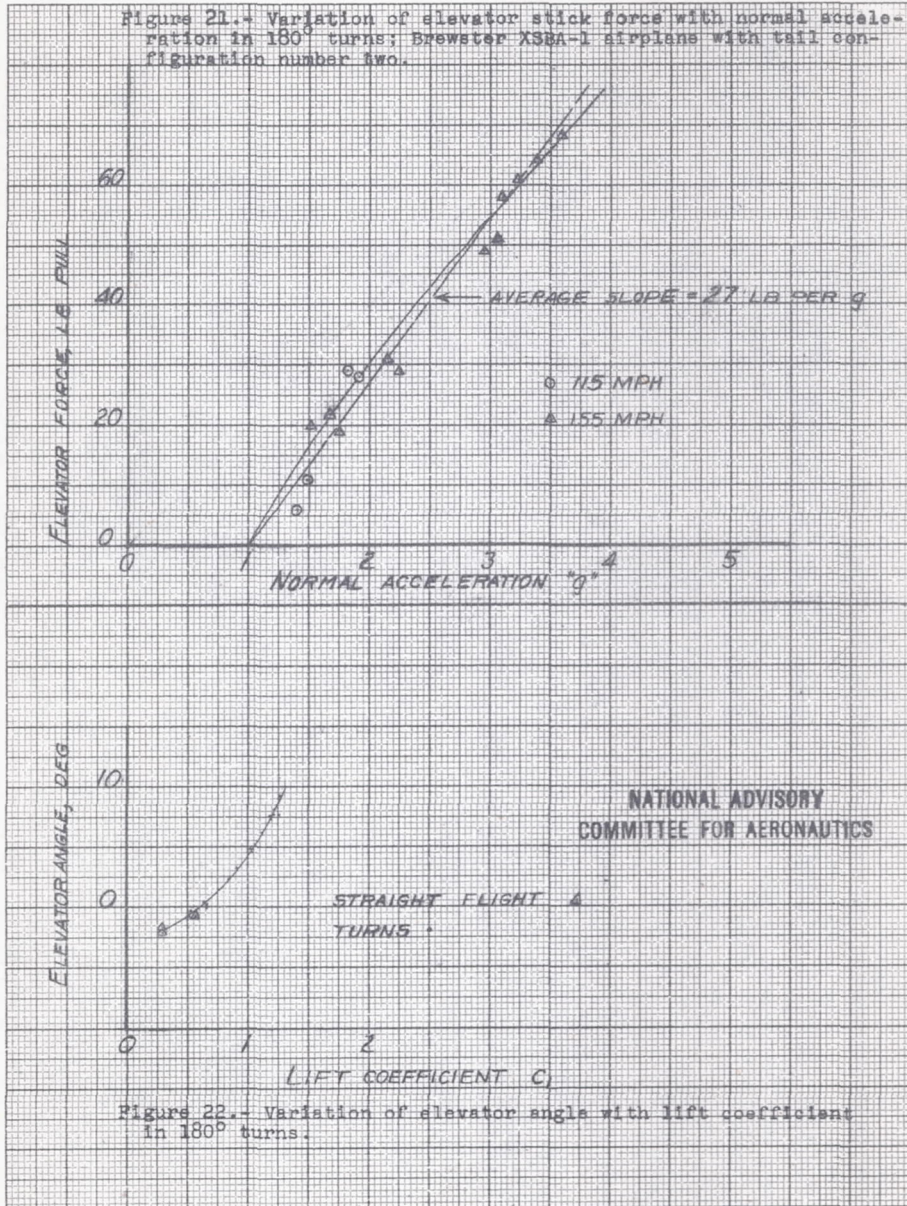
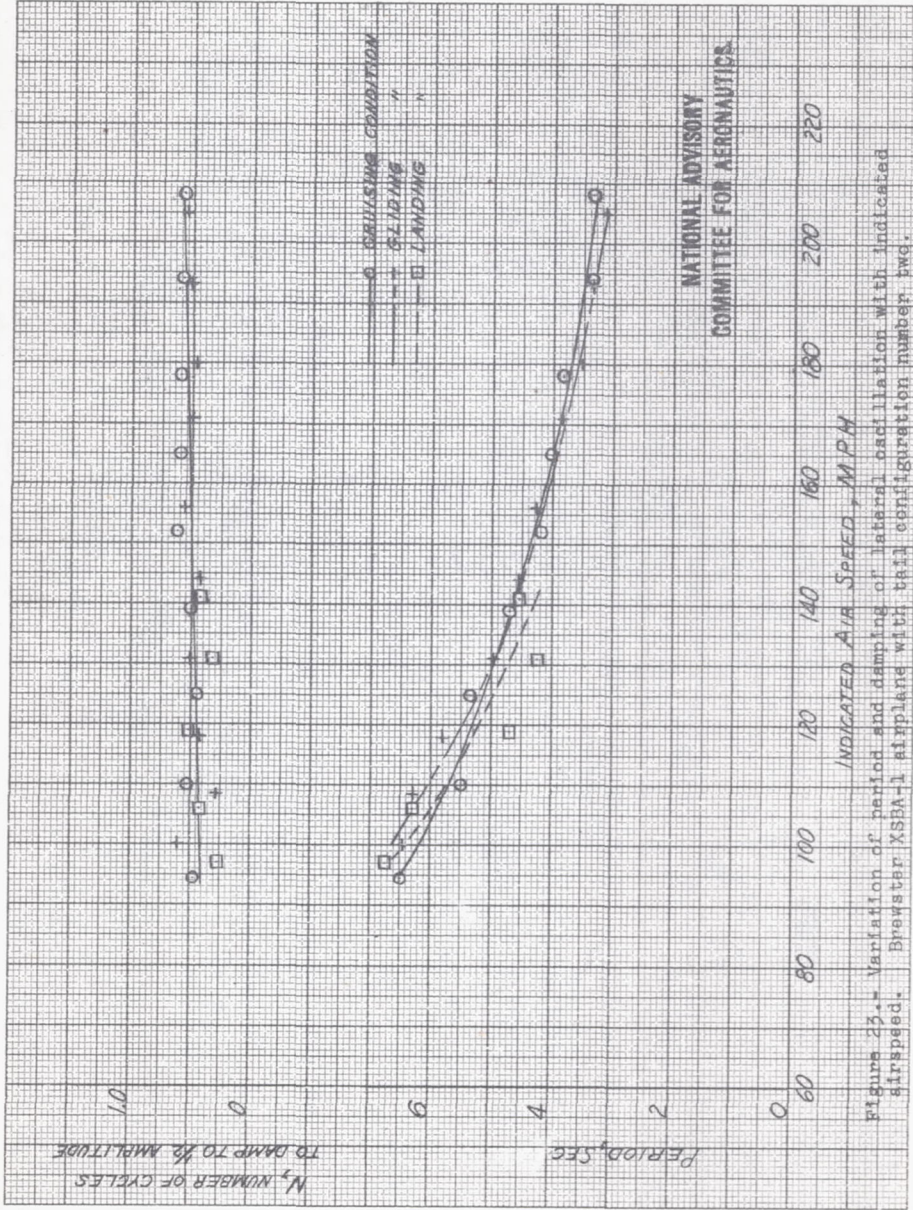

Figure 20.- Time history of a rapid 180° turn to the right started at 124 miles per hour. Brewster X5BA-1 airplane with tail configuration number two.





NATIONAL ADVISORY
COMMITTEE FOR AERONAUTICS

Figure 23. - Variation of period and damping of lateral oscillation with indicated airspeed. Brewster XSDA-1 airplane with tail configuration number two.

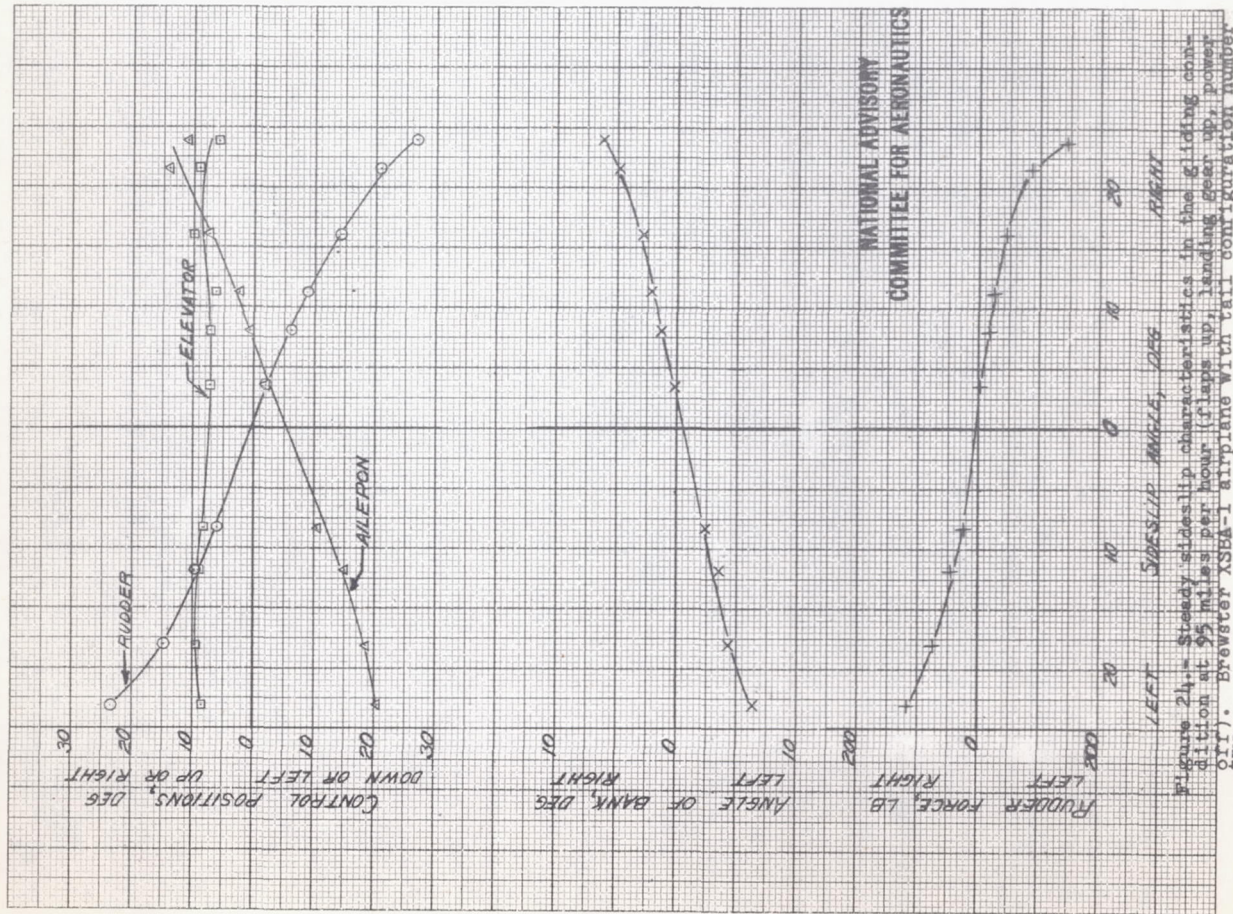

Figure 24. Steady sideslip characteristics in the gliding condition at 95 miles per hour (flaps up, landing gear up, power off). Brewster XSEB-1 airplane with tail configuration number two.

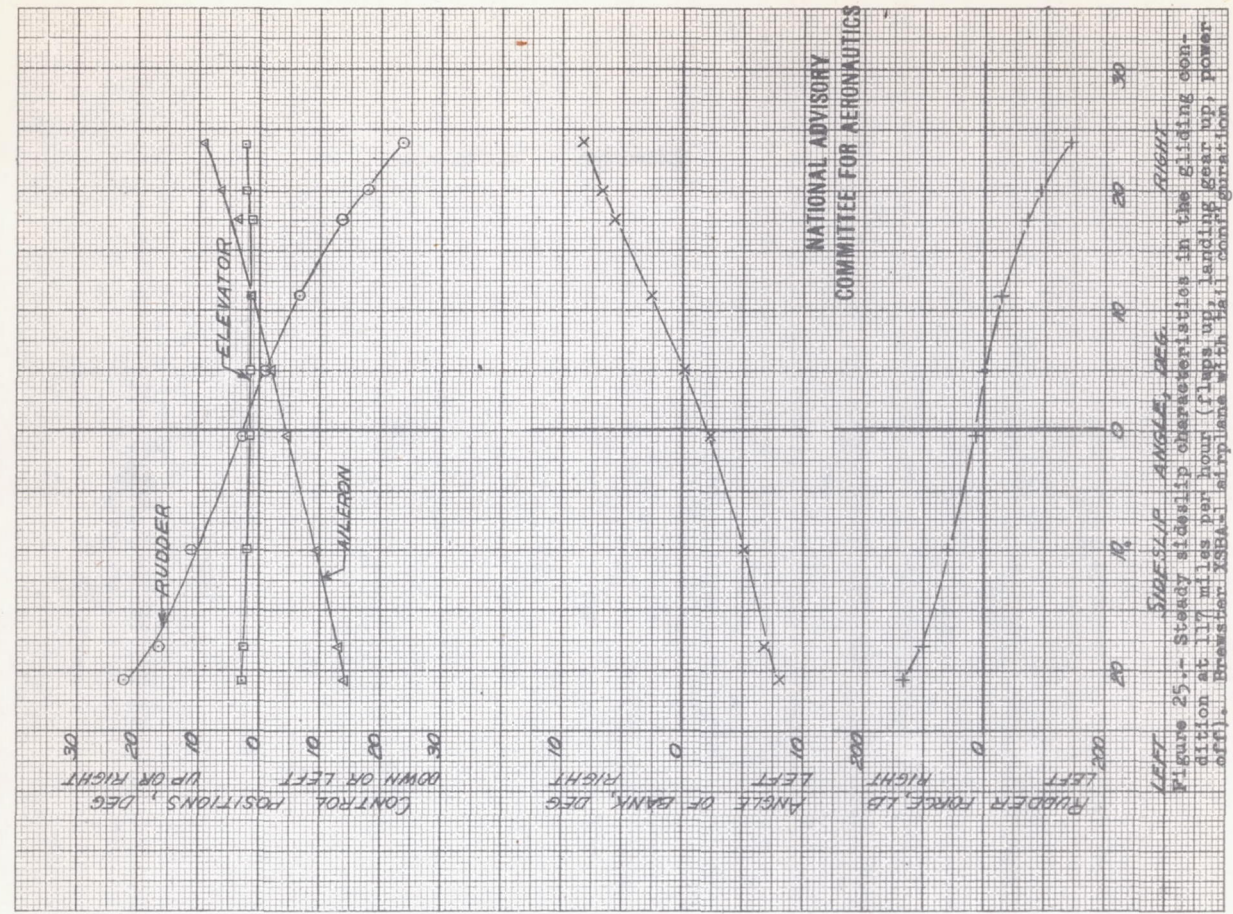
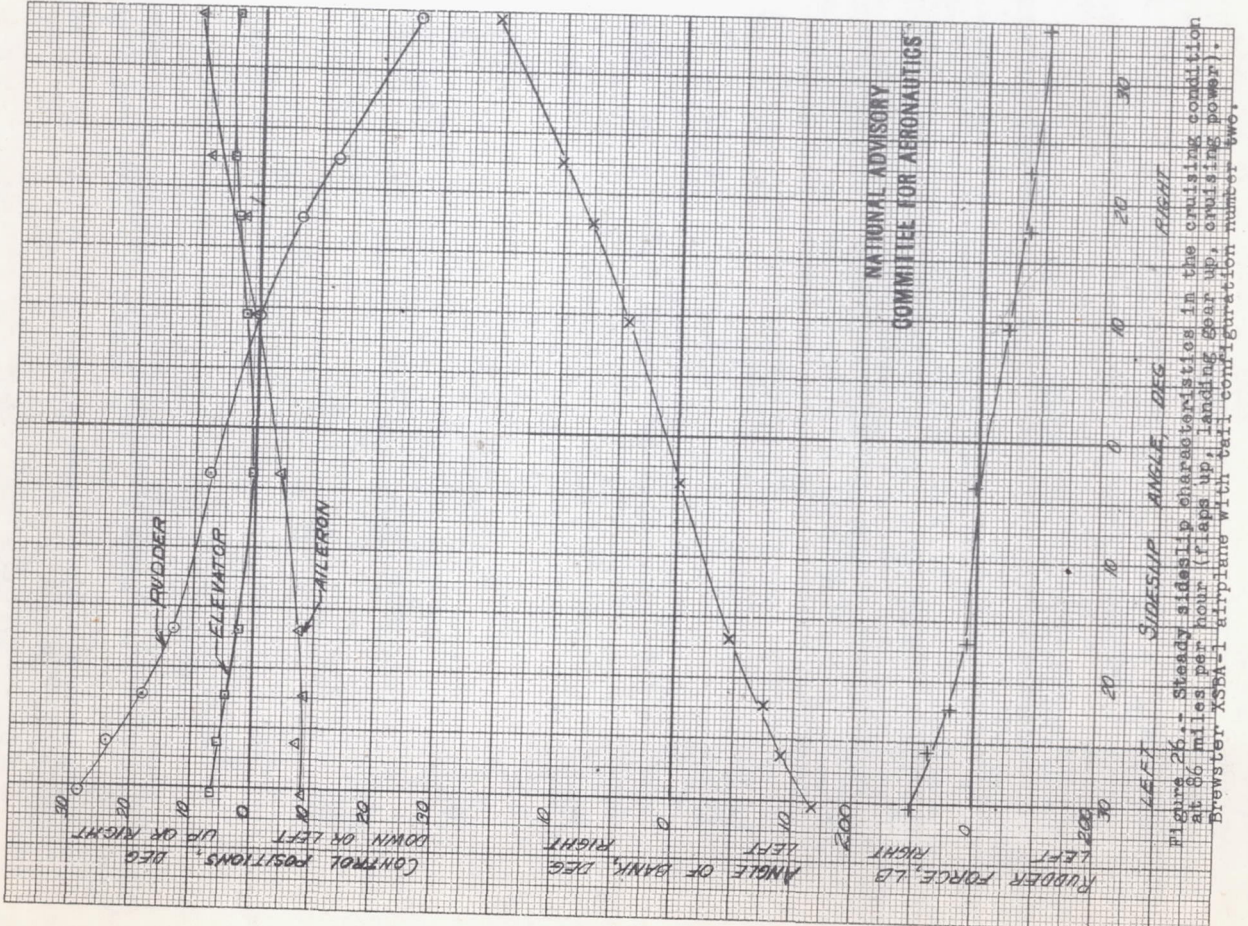
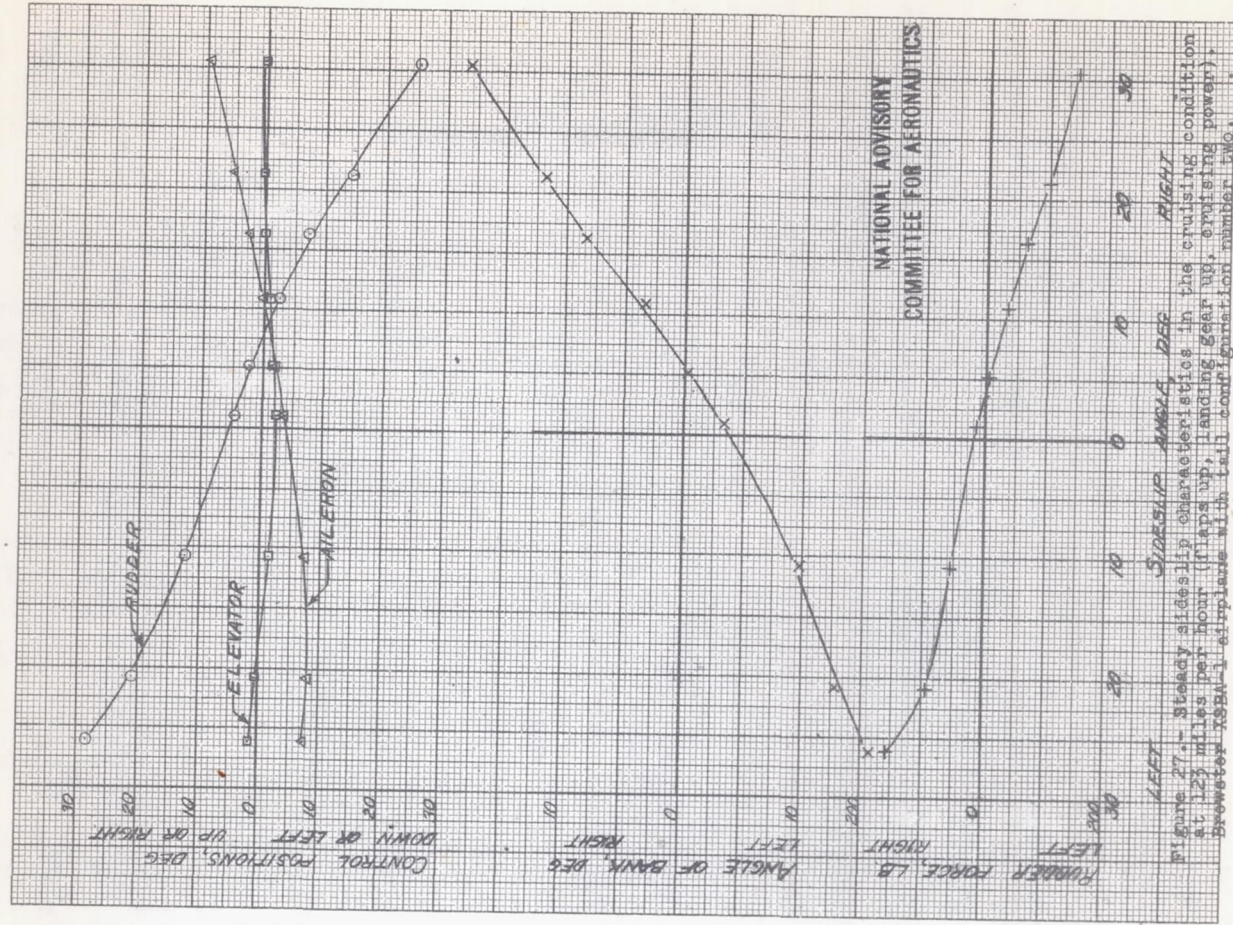

Figure 25. Steady sideslip characteristics in the gliding condition at 117 miles per hour (flaps up, landing gear up, power off). Brewster XSEB-1 airplane with tail configuration number two.

NATIONAL ADVISORY COMMITTEE FOR AERONAUTICS

NATIONAL ADVISORY COMMITTEE FOR AERONAUTICS



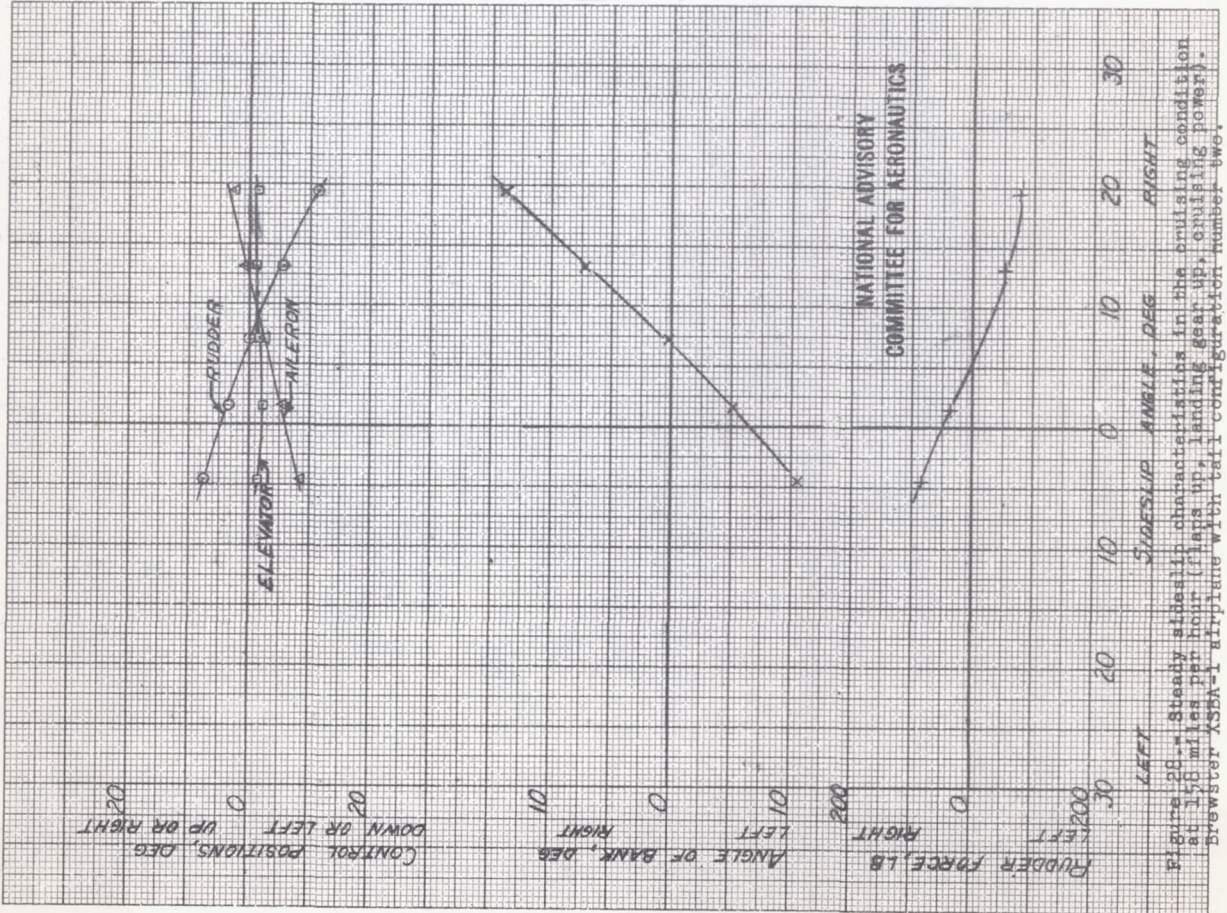

Figure 25.- Steady sidslip characteristics in the cruising condition at 150 miles per hour (flaps up, landing gear up, cruising power). Brewster A58A-1 airplane with tail configuration number two.

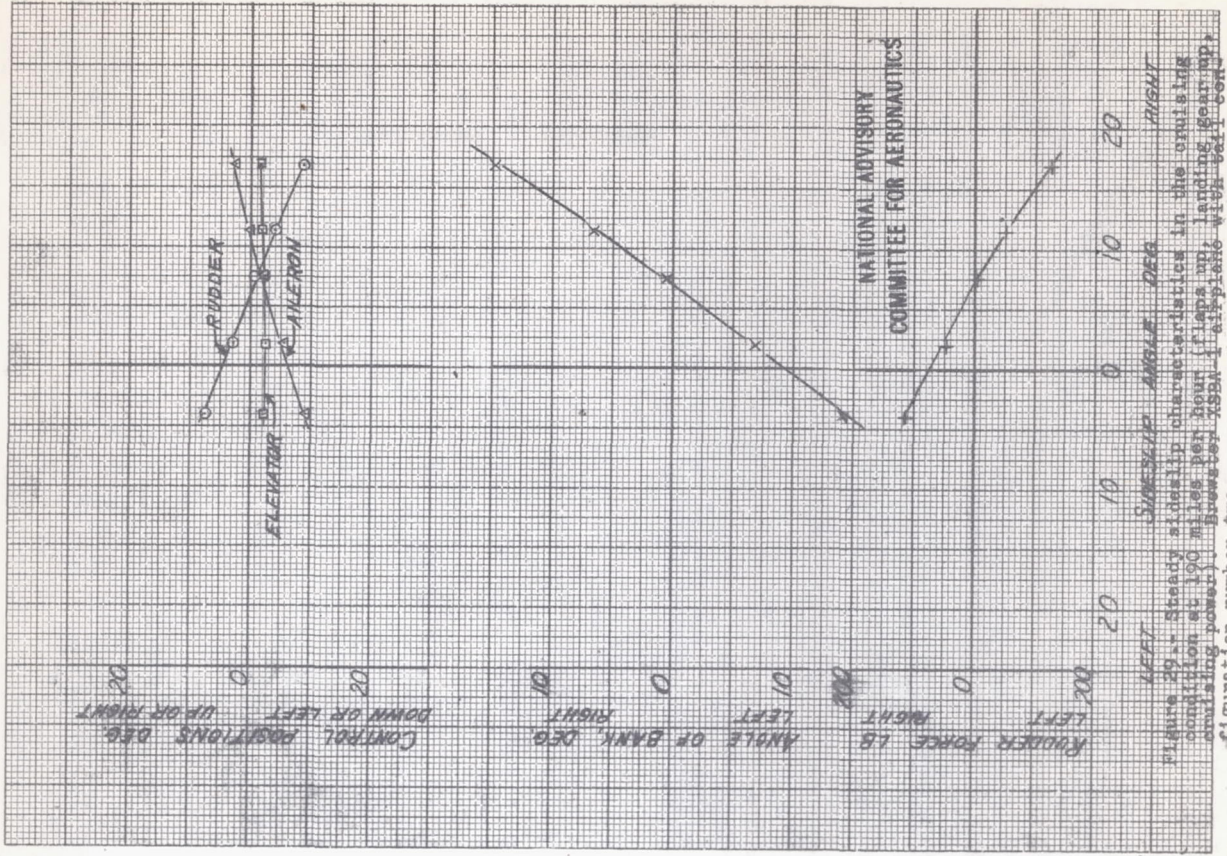

Figure 29.- Steady sidslip characteristics in the cruising condition at 190 miles per hour (flaps up, landing gear up, cruising power). Brewster A58A-1 airplane with tail configuration number two.

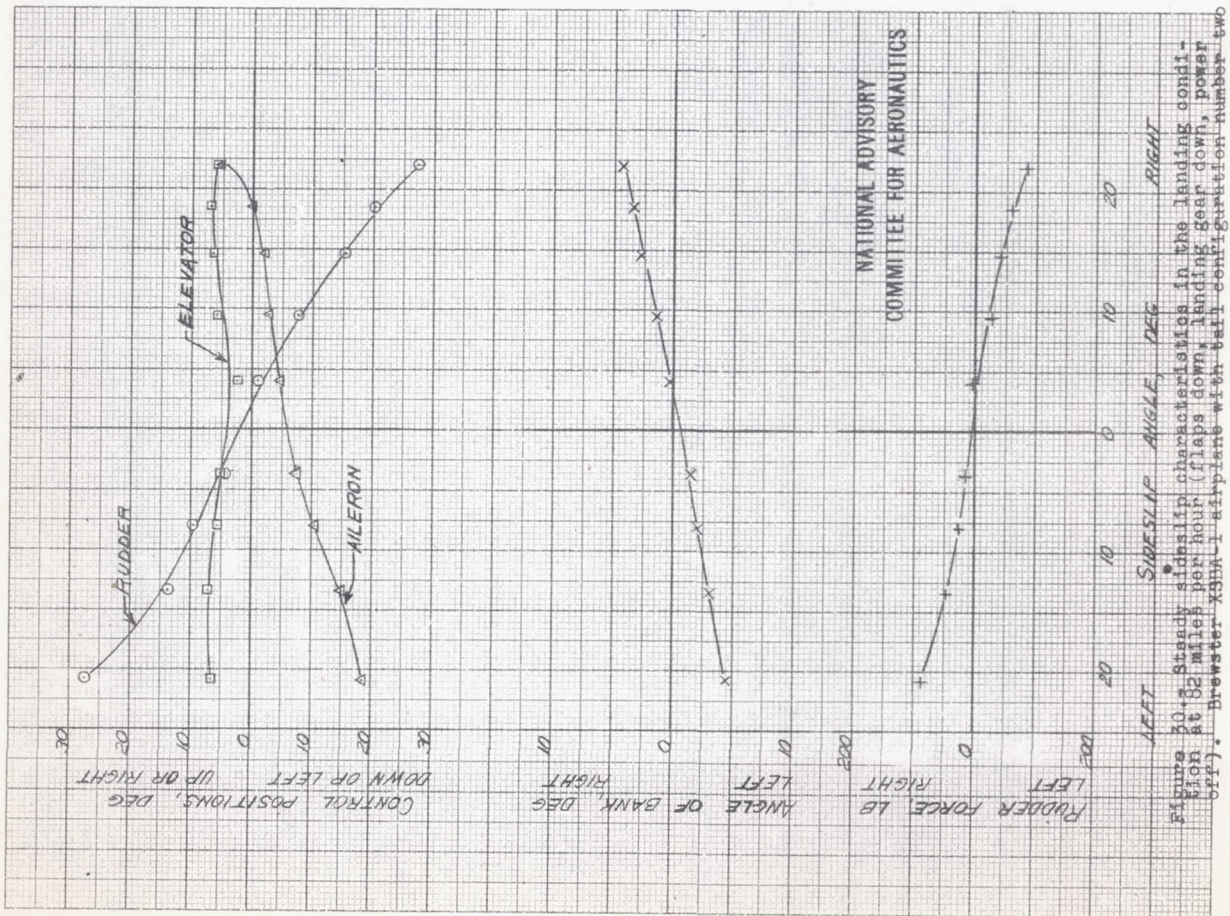

Figure 20. Steady sideslip characteristics in the landing condition at 82 miles per hour. (Flaps down, landing gear down, power off). Brewster X33A-1 airplane with tail configuration number two.

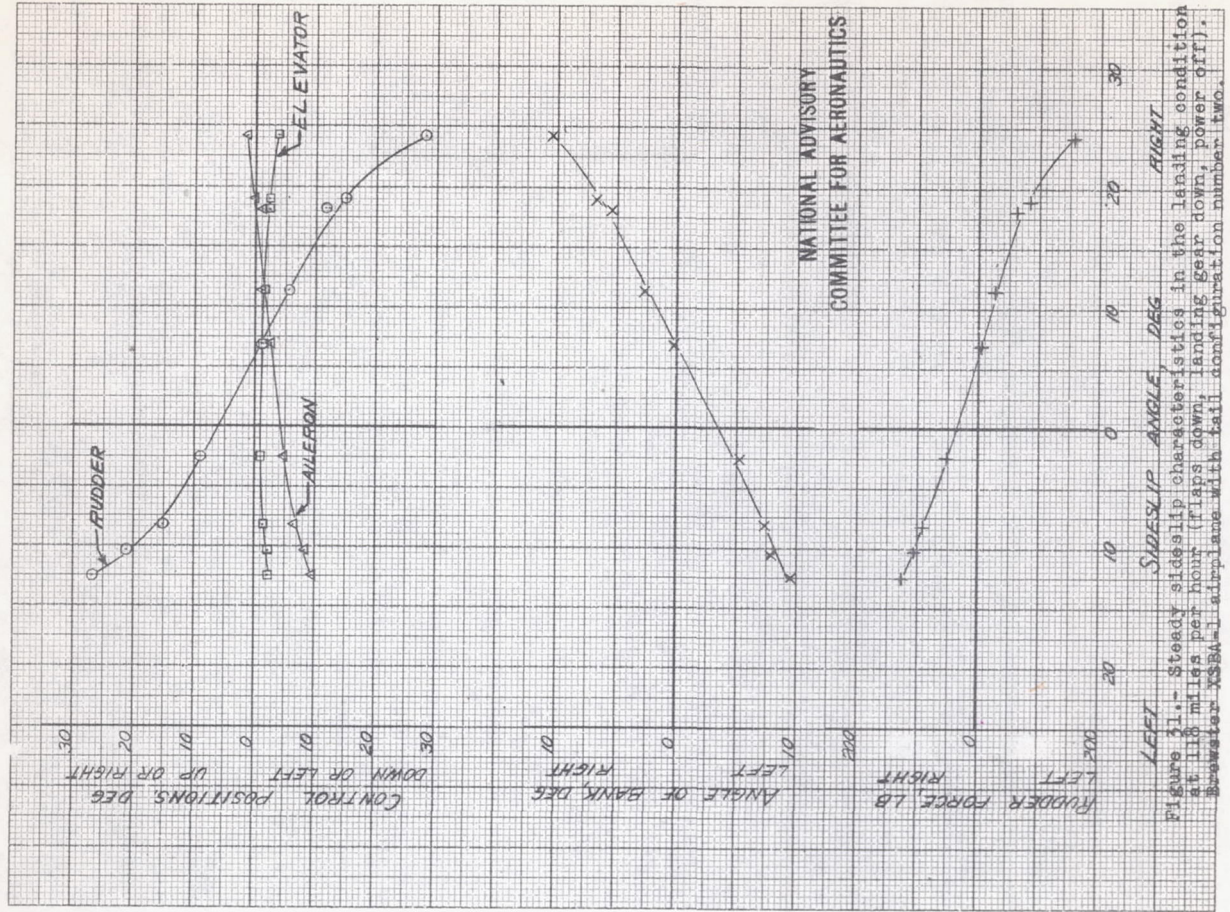

Figure 21. Steady sideslip characteristics in the landing condition at 110 miles per hour. (Flaps down, landing gear down, power off). Brewster X33A-1 airplane with tail configuration number two.

NATIONAL ADVISORY
COMMITTEE FOR AERONAUTICS

NATIONAL ADVISORY
COMMITTEE FOR AERONAUTICS

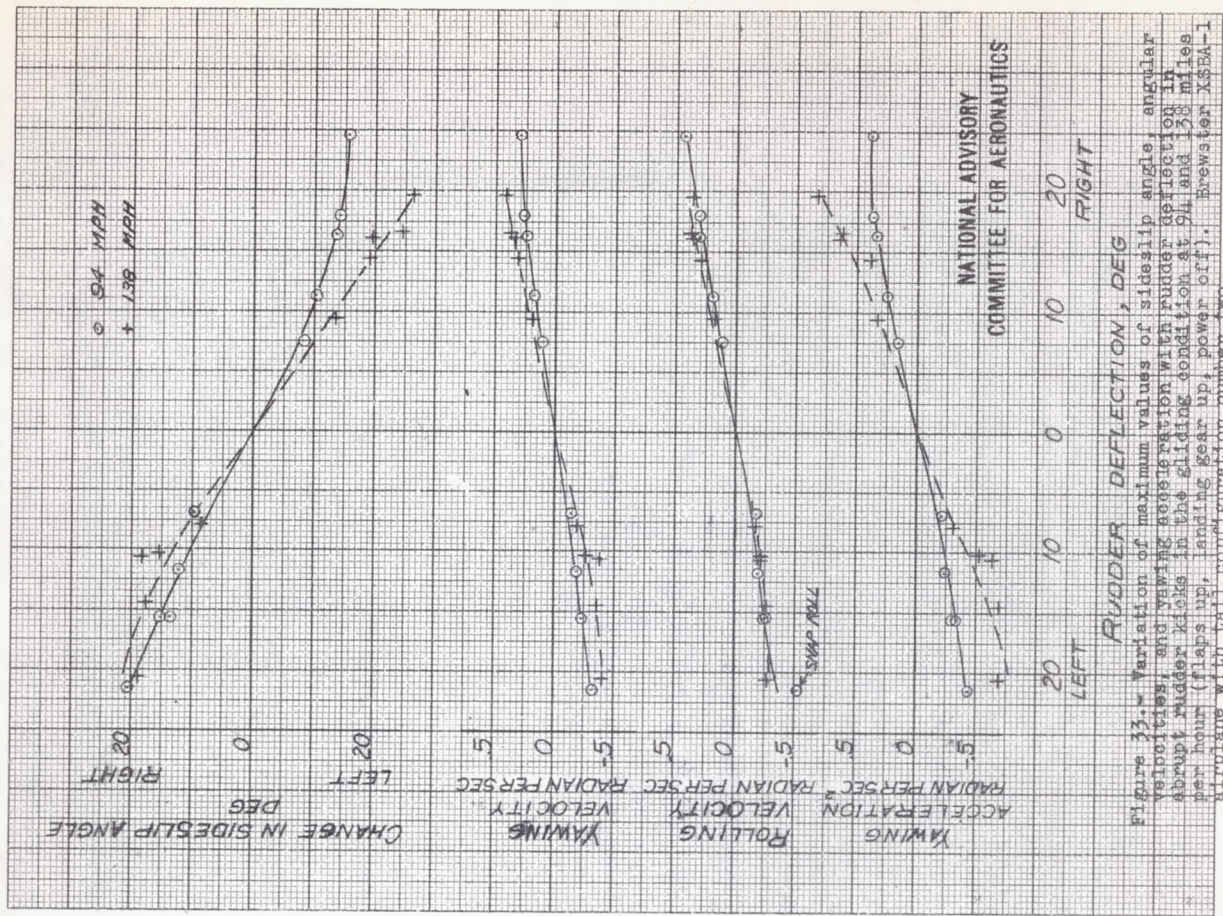

Figure 31.- Variation of maximum values of sideslip angle, angular velocities, and yawing acceleration with rudder deflection in abrupt rudder kicks in the gliding condition at 94 and 138 miles per hour (flaps up, landing gear up, power off). Brewster XSEA-1 airplane with tail configuration number two.

NATIONAL ADVISORY
COMMITTEE FOR AERONAUTICS

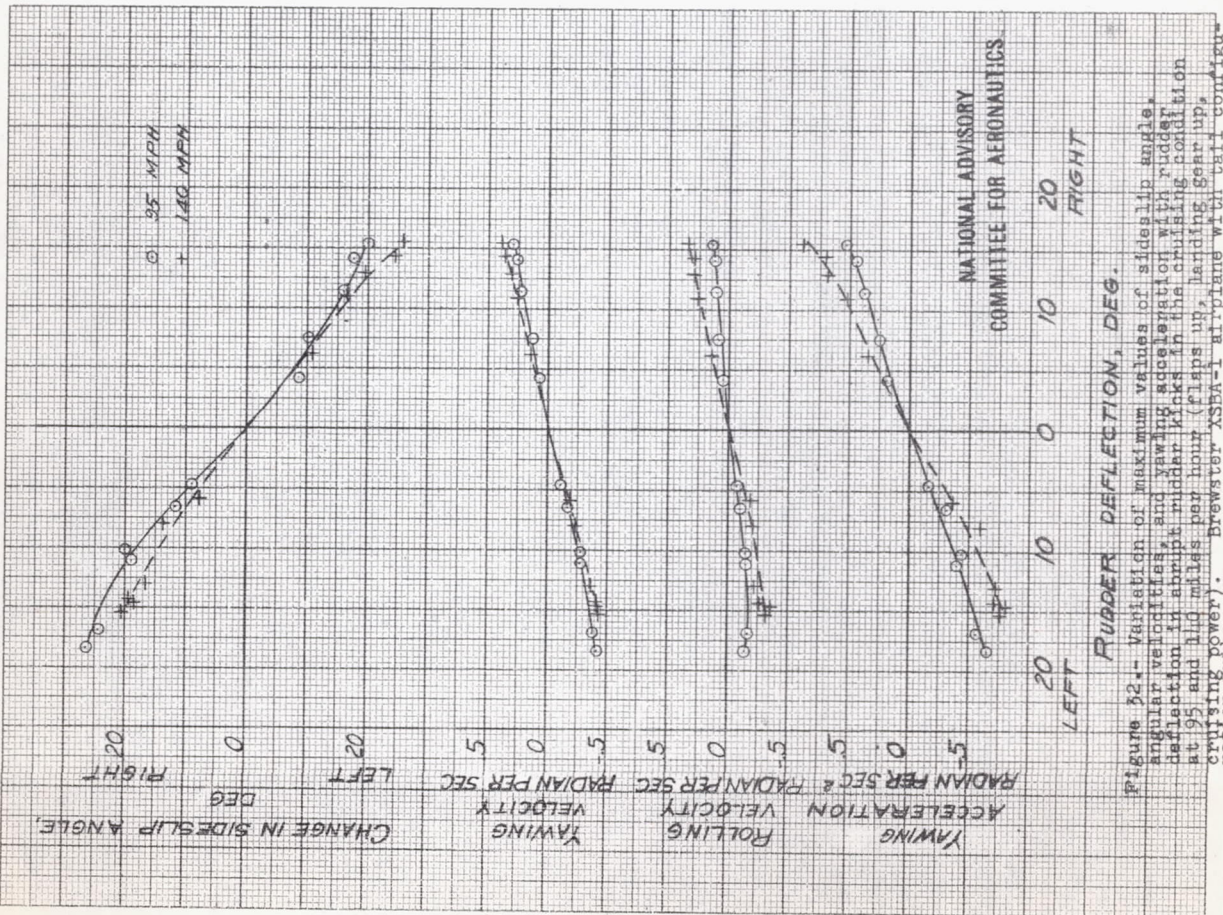

Figure 32.- Variation of maximum values of sideslip angle, angular velocities, and yawing acceleration with rudder deflection in abrupt rudder kicks in the cruising condition at 95 and 140 miles per hour (flaps up, landing gear up, cruising power). Brewster XSEA-1 airplane with tail configuration number two.

NATIONAL ADVISORY
COMMITTEE FOR AERONAUTICS

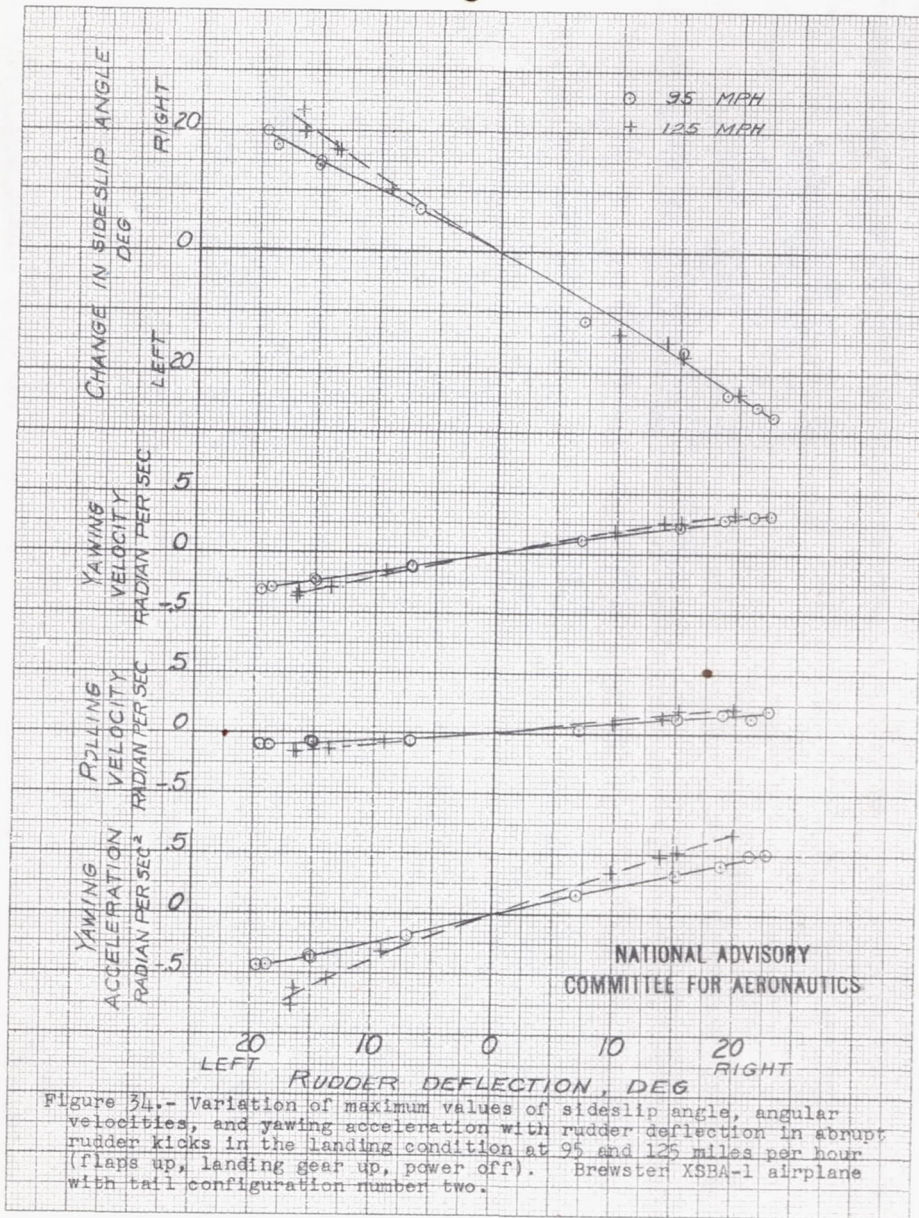

Figure 34.- Variation of maximum values of sideslip angle, angular velocities, and yawing acceleration with rudder deflection in abrupt rudder kicks in the landing condition at 95 and 125 miles per hour (flaps up, landing gear up, power off). Brewster XSBA-1 airplane with tail configuration number two.

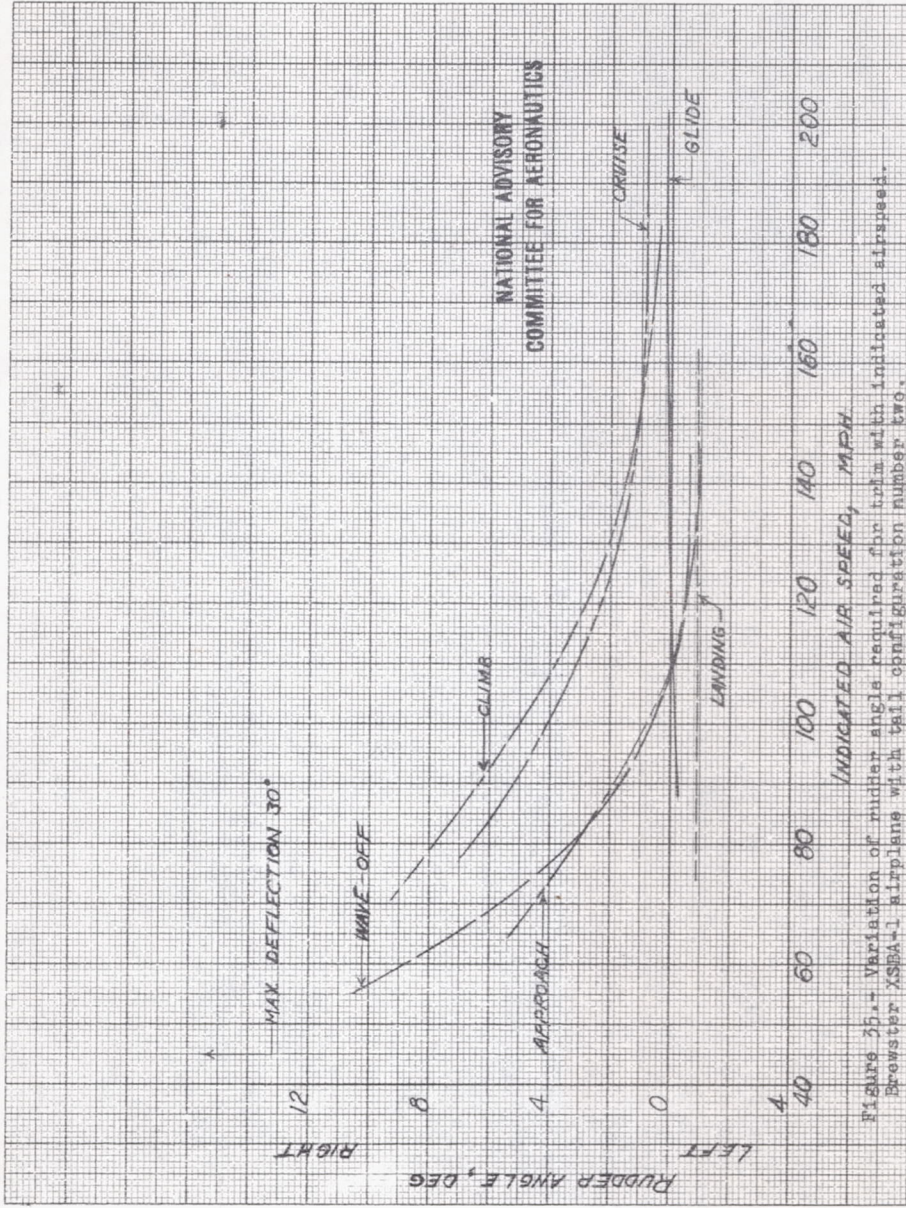

Figure 3b. Variation of rudder angle required for turn with indicated airspeed. Brewster XSPA-1 airplane with tail configuration number two.