

ACR No. L4D06

19 DEC 1947
NATIONAL ADVISORY COMMITTEE FOR AERONAUTICS

WARTIME REPORT

ORIGINALLY ISSUED

April 1944 as
Advance Confidential Report L4D06

PRELIMINARY TANK TESTS OF AN OUTBOARD FLOAT HAVING

THE FORM OF A STREAMLINE BODY OF REVOLUTION

FITTED WITH A HYDROFOIL

By Douglas A. King

Langley Memorial Aeronautical Laboratory
Langley Field, Va.

NACA

WASHINGTON

NACA LIBRARY
LANGLEY MEMORIAL AERONAUTICAL
LABORATORY
Langley Field, Va.

NACA WARTIME REPORTS are reprints of papers originally issued to provide rapid distribution of advance research results to an authorized group requiring them for the war effort. They were previously held under a security status but are now unclassified. Some of these reports were not technically edited. All have been reproduced without change in order to expedite general distribution.

NATIONAL ADVISORY COMMITTEE FOR AERONAUTICS

ADVANCE CONFIDENTIAL REPORT NO. L4D06

PRELIMINARY TANK TESTS OF AN OUTBOARD FLOAT HAVING
THE FORM OF A STREAMLINE BODY OF REVOLUTION
FITTED WITH A HYDROFOIL

By Douglas A. King

SUMMARY

Preliminary tests were made in NACA tank no. 1 to investigate the hydrodynamic qualities of a streamline body of revolution of a fineness ratio of 5.14, both alone and with a lifting hydrofoil. The hydrofoil, supported below the body by means of struts that gave the effect of end plates at the tips of the hydrofoil, had a chord about 48 percent of the maximum diameter of the body, an aspect ratio of 1.92, and a dihedral angle of 30° .

In general, at constant drafts, the lift of the streamline body without the hydrofoil decreased with increasing speed. When the trim of the body was 5° and the body was not wholly submerged, for any two values of draft, the speed at which the lift became negative was greater for the greater draft than for the lesser. When the trim of the body was increased to 10° and the body was completely submerged, the lift did not vary greatly with speed. The resistance of the body in this condition was of the same order of magnitude as the lift. At high trims the hydrodynamic lift-resistance ratios of the streamline body with the hydrofoil were higher than those of a conventional outboard float.

The aerodynamic drag of the combination of streamline body and hydrofoil was computed and compared with that of several conventional outboard floats. The minimum drag of the combination was about 50 percent of the average minimum drag of the conventional floats. The combination at an angle of attack of 0° and an angle of incidence of the hydrofoil of 10° had a drag about 50 percent of the average drag of the conventional floats at an angle of attack of 0° based on the keel just forward of the step, and about 35 percent of the average drag of the conventional floats at an angle of attack of 5° .

INTRODUCTION

Conventional flying boats and single-float seaplanes are inherently unstable in roll while at rest or taxiing at low speeds and external means for providing lateral stability on the water must be provided. The usual method of providing lateral stability is by the use of outboard floats. When the airplane heels while at rest, one of the outboard floats is immersed and, as the extent of immersion increases, the displacement increases; thus a righting moment is produced that increases until the rolling moment exerted by the airplane is balanced by the righting moment produced by the outboard float. When the airplane is taxiing, the righting moment of the outboard floats is produced by a combination of buoyancy and dynamic lift. The dynamic lift should be as large as possible compared with the buoyancy of the float, and the resistance of the float should be as small as possible to reduce yawing moments and structural loads.

In flight, outboard floats are a direct source of drag and are therefore objectionable. This drag may be either eliminated by retracting the floats completely into the airframe or reduced by providing floats of a more streamline form.

The retraction of floats into the airframe offers obvious possibilities for the reduction of drag, but some difficulties arise in the actual design and construction. The design of the struts supporting a retractable float is more difficult than that of struts supporting a fixed float. The retracting mechanism adds to the structural weight and complexity of the airplane. In addition, the limitations imposed by such requirements as space and location incidental to the retraction of the float may lead to the design of a float that has poor hydrodynamic characteristics.

Hydrodynamic lifting forces on conventional floats are produced by the action of the water on relatively flat planing surfaces. Sharp discontinuities at the edges of these planing surfaces have been considered necessary to insure useful lift-resistance ratios. The planing surfaces and their attendant sharp discontinuities cause the drag of a float to be greater than that of a streamline body of the same volume and fineness ratio.

The use of a simple streamline body without a planing bottom is not feasible because, when such a body is moved along the surface of the water, a downward force is generated on the wetted surface. The body tends to sink to a greater draft rather than to develop lift. This action is in accordance with theory and with the tests of earlier experimenters (reference 1).

The hydrodynamic lift that is required may be provided by combining a hydrofoil (or hydrofoils) with the streamline body. The hydrofoil should be arranged to develop dynamic lift forces that are large compared with the static buoyancy forces developed by the streamline body. If the hydrofoil has less drag than the planing surfaces necessary to give the same hydrodynamic lift-resistance ratio, the combination of streamline body and hydrofoil becomes of interest as an alternate to the conventional outboard float.

Although the fact had been established that a streamline body would tend to be sucked down when moved along the surface of the water, it was believed that the magnitude of the suction force and the manner in which it varied with speed and draft had not been determined. The magnitude of the lift of a hydrofoil that might be used in combination with a streamline body and the manner in which the lift should vary could therefore not be estimated. In order to obtain information regarding the possibilities of this type of float, short preliminary tests were made in NACA tank no. 1 of a streamline body and of the body in combination with a hydrofoil.

MODEL

The model tested, a streamline body of revolution with a length of 26.94 inches and a maximum diameter of 5.24 inches, is shown in figure 1. The body has a volume of 0.1975 cubic foot and a fineness ratio of 5.14. The form was obtained by scaling down body 1, nose 1 of reference 2 to the size desired for these tests. Off-sets of the body are given in table I.

The hydrofoil is of the NACA 16-509 airfoil section with a chord of 2.5 inches and is set at an angle of incidence of 0° relative to the center line of the body. Ordinates of the hydrofoil section are given in table II. The struts supporting the hydrofoil are of lenticular

section with a chord of 2.5 inches and a maximum thickness of $\frac{1}{8}$ -inch. The recesses formed in the body to receive the hydrofoil struts and the strut supporting the model were filled with beeswax to give a smooth, fair surface.

APPARATUS AND TEST PROCEDURE

The tests were conducted on October 9, 1943 in NACA tank no. 1, which was described in reference 3. The depth of the water for these tests was 6 feet; the towing gear was arranged as shown in figure 2. It was possible to measure both lift and resistance and to set the trim and draft to any values within the range of the apparatus. A spray plate about 2 feet square was mounted on the rectangular towing staff to prevent spray from wetting the towing gear. The model and towing staff were weighted to about 80 pounds. Inasmuch as the lift of the model was determined by measuring the apparent weight of the model and towing staff (actual weight of the model and staff minus the hydrodynamic lift of the model), it was possible to measure lift forces up to about 80 pounds.

The model was towed at fixed trim and at constant speeds varying from 0 to 30 feet per second. The draft of the model was changed by constant increments as the towing carriage moved along the tank and lift and resistance were measured at each draft. The model was also towed while wholly in air and the lift and resistance obtained from these tests were subtracted from the gross measurements to obtain the hydrodynamic forces acting on the model. Lift and resistance were measured only at increasing values of draft, and trimming moments were not measured. Trim τ was measured to the center line of the streamline body. Draft was measured to the lowest point on the model exclusive of the hydrofoil.

The accuracy of measurement is estimated to be as follows:

Speed, foot per second	±0.1
Lift, pound	±0.5
Resistance, pound	±0.2
Trim, degree	±0.1
Draft, inch	±0.1

RESULTS

The results of the tests are given in the form of curves of lift L , resistance R , and lift-resistance ratio L/R plotted against speed with trim and draft as parameters (figs. 3 to 7).

Streamline body without hydrofoil.- In figure 3, the lift of the streamline body at a trim of 5° decreased with increasing speed and became negative at speeds that increased with increasing draft. At a trim of 10° (fig. 4) the lift of the streamline body became negative only at drafts of 1, 2, and 3 inches at speeds approximately the same as for similar drafts at a trim of 5° . When the body was completely submerged -that is, at drafts of 7 and 8 inches -the lift at a trim of 10° decreased slightly with increasing speed, reached a minimum at about 15 feet per second, and then increased. At the greater draft, 8 inches, the lift increased to a value about equal to the static lift but at the lesser draft, 7 inches, the lift at 30 feet per second was about 75 percent of the static lift.

The resistance at trims of 5° and 10° increased both with increasing speed and with increasing draft. At drafts greater than 2 inches, the resistance at 10° trim was greater than the resistance at 5° trim.

The results shown in figures 3 and 4 suggest that the lift of the streamline body, when fully submerged, may be made greater than the static lift by increasing the trim but that the resistance of the body in this condition will be of the same order of magnitude as the lift.

Streamline body with hydrofoil.- Figures 5 to 7 show that the lift increased with the trim and that the hydrofoil developed the major portion of the lift. The resistance and lift-resistance ratio increased with increasing trim.

DISCUSSION OF RESULTS

Interference.- The curves of effective lift and resistance in figures 8 and 9 were prepared by subtracting the lift and resistance of the hydrofoil alone (streamline

body with hydrofoil at draft of 0 inch) from the lift and resistance of the streamline body with hydrofoil. A comparison of figures 8 and 9 with figures 3 and 4 shows that the effective lift and resistance of the streamline body are approximately the same as the actual lift and resistance measured on the body alone. At a trim of 5° the effective lift was less and the effective resistance was greater than the values for the body alone. At a trim of 10° and at speeds greater than 25 feet per second, the effective lift and resistance were greater than the values for the body alone. The difference between the effective lift and the actual lift of the body was small compared with the lift of the hydrofoil. The forces on a combination of a body and a hydrofoil may therefore be determined with a fair degree of accuracy by simply adding the forces on the body and the hydrofoil and neglecting the effects of interference.

Incidence.- The tests were made with the hydrofoil at one angle of incidence, 0° . At any trim of the body, the lift of the body with the hydrofoil would be increased by increasing the angle of incidence of the hydrofoil. For a reasonable increase in the angle of incidence, the lift-resistance ratio would be increased.

Spray.- Spray at large drafts, 4 to 8 inches, did not appear to be heavier than the spray of conventional outboard floats of similar size at comparable drafts and speeds. The operator could not adequately observe the spray because the spray plate on the towing gear was between the operator's seat on the towing carriage and the model. At large drafts and high speeds, the spray that was thrown upward and struck the spray plate of the towing gear may have developed a lift force of unknown magnitude. This lift force was probably not large compared with the lift of the model.

Trimming moment.- The trimming moment of an outboard float appears to be of secondary importance. The trimming moment of a combination of streamline body and hydrofoil may, however, be varied by changing the longitudinal position of the hydrofoil. The variation of the longitudinal position of the hydrofoil should not greatly affect the hydrodynamic lift and resistance of the combination.

Comparison with conventional float.- Figure 10 shows the lift and resistance characteristics of NACA model 104-A taken from unpublished tests. The NACA model 104-A, a $\frac{1}{5}$ -size model

of the PBY-type outboard float, had a volume of 0.1975 cubic foot and was tested in the same manner and with the same apparatus as the streamline body. A comparison of figure 10 with the results of the present tests shows that the lift-resistance ratios of the streamline body with hydrofoil at trims of 5° and 10° are higher than those of NACA model 104-A at a trim of 13° .

Aerodynamic drag.- An approximation of the aerodynamic drag of the combination of the streamline body and hydrofoil was made by adding the separate drag coefficients of the constituent parts, based on (volume)^{2/3} of the streamline body.

The drag coefficient of the streamline body at an angle of attack of 0° , Mach number of approximately 0.35, and Reynolds number of approximately 12×10^6 was computed from the value given in table IV of reference 2. The drag coefficient of the hydrofoil at an angle of attack of 0° , Reynolds number of approximately 1.46×10^6 , was computed from figure 20 of reference 4, after correcting for aspect ratio. The geometrical aspect ratio of the hydrofoil was 1.92, but the struts supporting the hydrofoil effectively increased the aspect ratio by an undetermined amount. An effective aspect ratio of 3 was assumed. The drag coefficient of the struts supporting the hydrofoil was computed from figure 91 of reference 5. The drag coefficient of the combination of streamline body and hydrofoil thus obtained was as follows:

	C_D
Streamline body	0.0208
Hydrofoil	.0044
Hydrofoil struts	.0030
Total	0.0282

Increasing the angle of incidence of the hydrofoil from 0° to 10° increased the total drag coefficient from 0.028 to 0.046.

The drag coefficients based on (volume)^{2/3} of each of four outboard floats (figs. 20 and 21 of reference 6) at several trims were as follows:

Trim (deg)	C _D	Av. C _D of four floats
For min. drag	0.029 to 0.095	0.055
0	0.064 to 0.131	0.088
5	0.081 to 0.175	0.124

The trim was measured to the keel just forward of the step. The trims for minimum drag ranged from -5° to -13°.

The combination of streamline body and hydrofoil had a minimum drag about 50 percent of the average minimum drag of the conventional floats. At an angle of attack of 0° and an angle of incidence of the hydrofoil of 10°, the combination had a drag about 50 percent of the average drag of the conventional floats at a trim of 0° and about 35 percent of the average drag of the conventional floats at a trim of 5°. The comparison with the conventional floats at a trim of 5° is considered the most representative of actual practice of these comparisons, because, in order to produce about the same hydrodynamic characteristics as the combination of streamline body and hydrofoil, an average outboard float would have an angle of incidence several degrees higher than the combination.

CONCLUSIONS

The following conclusions are valid only for the streamline body and hydrofoil tested but may be reasonably expected to be applicable to similar configurations:

1. The lift of a streamline body moving partially submerged over the surface of the water at constant draft decreased with increasing speed and, when the body was below a certain trim, became negative at speeds that increased with increasing values of draft.

2. When the body was completely submerged, and at a sufficiently high trim, the lift of the streamline body did not decrease very much with increasing speed and became

greater than the static lift. The resistance in this condition was of the same order of magnitude as the lift.

3. For a first approximation, the hydrodynamic forces on a combination of a streamline body and a hydrofoil may be obtained by adding the forces on the separate constituents and neglecting the interference between the body and the hydrofoil.

4. At high trims the hydrodynamic lift-resistance ratios of the streamline body with the hydrofoil were higher than those of a conventional outboard float.

5. The combination of streamline body and hydrofoil had a lower aerodynamic drag than a conventional float of the same volume.

Langley Memorial Aeronautical Laboratory,
National Advisory Committee for Aeronautics,
Langley Field, Va.

REFERENCES

1. Langley, Marcus: Seaplane Float and Hull Design, Sir Isaac Pitman & Sons, Ltd., (London), 1935.
2. Draley, Eugene C.: High-Speed Drag Tests of Several Fuselage Shapes in Combination with a Wing. NACA ACR, Aug. 1940.
3. Truscott, Starr: The Enlarged N.A.C.A. Tank, and Some of Its Work. NACA TM No. 918, 1939.
4. Benson, James M., and Land, Norman S.: An Investigation of Hydrofoils in the NACA Tank. I - Effect of Dihedral and Depth of Submersion. NACA ACR, Sept. 1942.
5. Jacobs, Eastman N., Ward, Kenneth E., and Pinkerton, Robert M.: The Characteristics of 78 Related Airfoil Sections from Tests in the Variable-Density Wind Tunnel. NACA Rep. No. 460, 1933.
6. Dawson, John R., and Hartman, Edwin P.: Hydrodynamic and Aerodynamic Tests of Four Models of Outboard Floats (N.A.C.A. Models 51-A, 51-B, 51-C, and 51-D). NACA TN No. 678, 1938.

TABLE I.- OFFSETS OF STREAMLINE BODY TESTED

Distance from nose (in.)	Radius (in.)
0	0
.39	.55
.72	.82
1.39	1.23
2.74	1.77
4.17	2.12
5.43	2.33
8.12	2.57
10.49	2.62
13.50	2.55
16.19	2.33
18.88	1.93
21.57	1.35
22.91	1.03
24.25	.70
25.60	.35
26.27	.18
26.94	0

TABLE II.- ORDINATES OF NACA 16-509 SECTION HYDROFOIL

[Stations and ordinates in percent of chord]

Upper surface		Lower surface	
Station	Ordinate	Station	Ordinate
0	0	0	0
1.084	1.223	1.416	-.687
2.305	1.805	2.695	-.875
4.781	2.659	5.219	-1.079
7.274	3.323	7.726	-1.203
9.774	3.877	10.226	-1.289
14.786	4.776	15.214	-1.412
19.807	5.484	20.193	-1.502
29.863	6.492	30.137	-1.630
39.929	7.068	40.071	-1.712
50.000	7.258	50.000	-1.742
60.071	7.053	59.929	-1.697
70.133	6.381	69.867	-1.519
80.173	5.135	79.827	-1.153
90.164	3.175	89.836	-.587
95.123	1.844	94.877	-.264
100.027	.086	99.973	-.086

L.E. radius: 0.40.
Slope of radius through end of chord: 0.3117

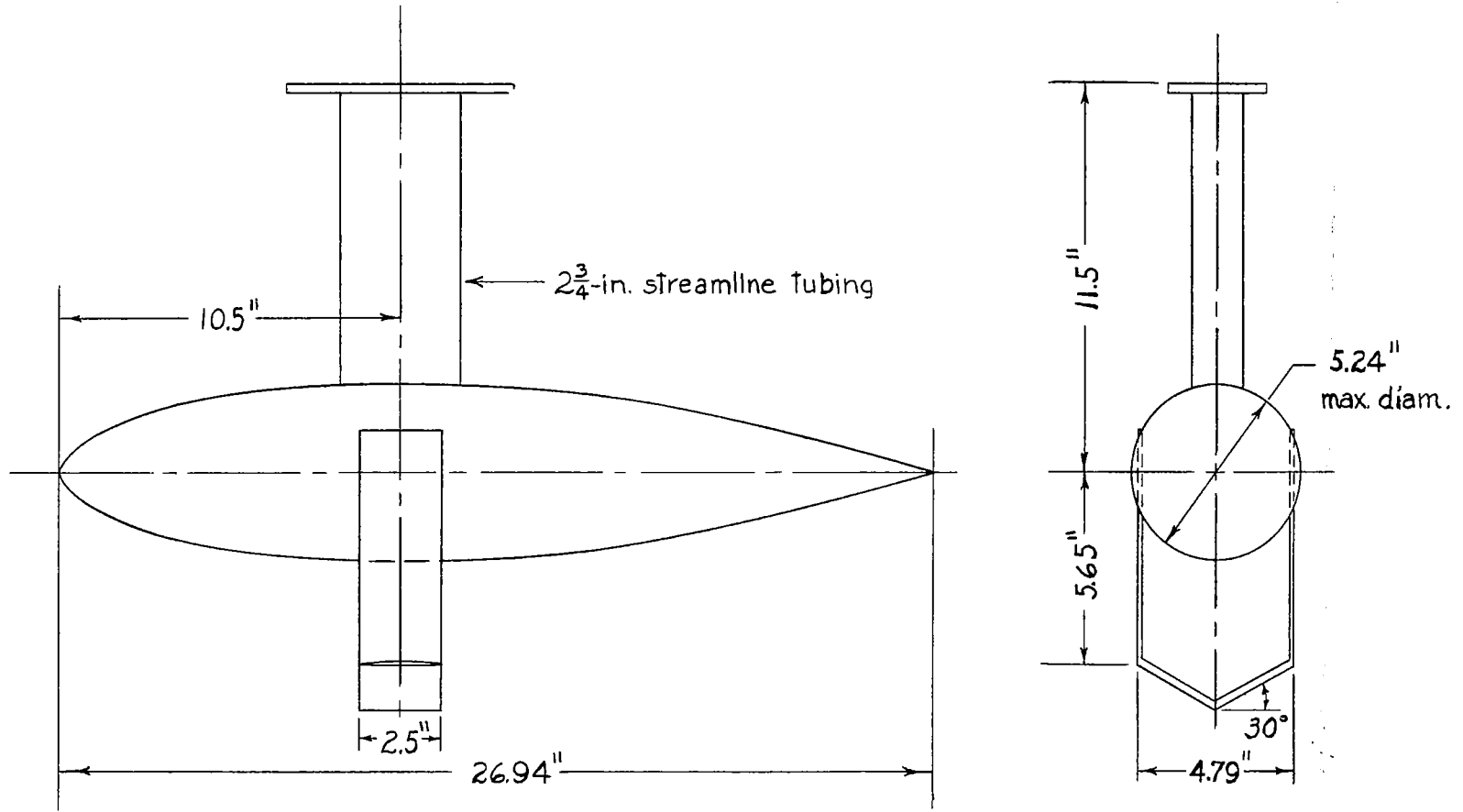

Figure 1.- Sketch of model with hydrofoil.

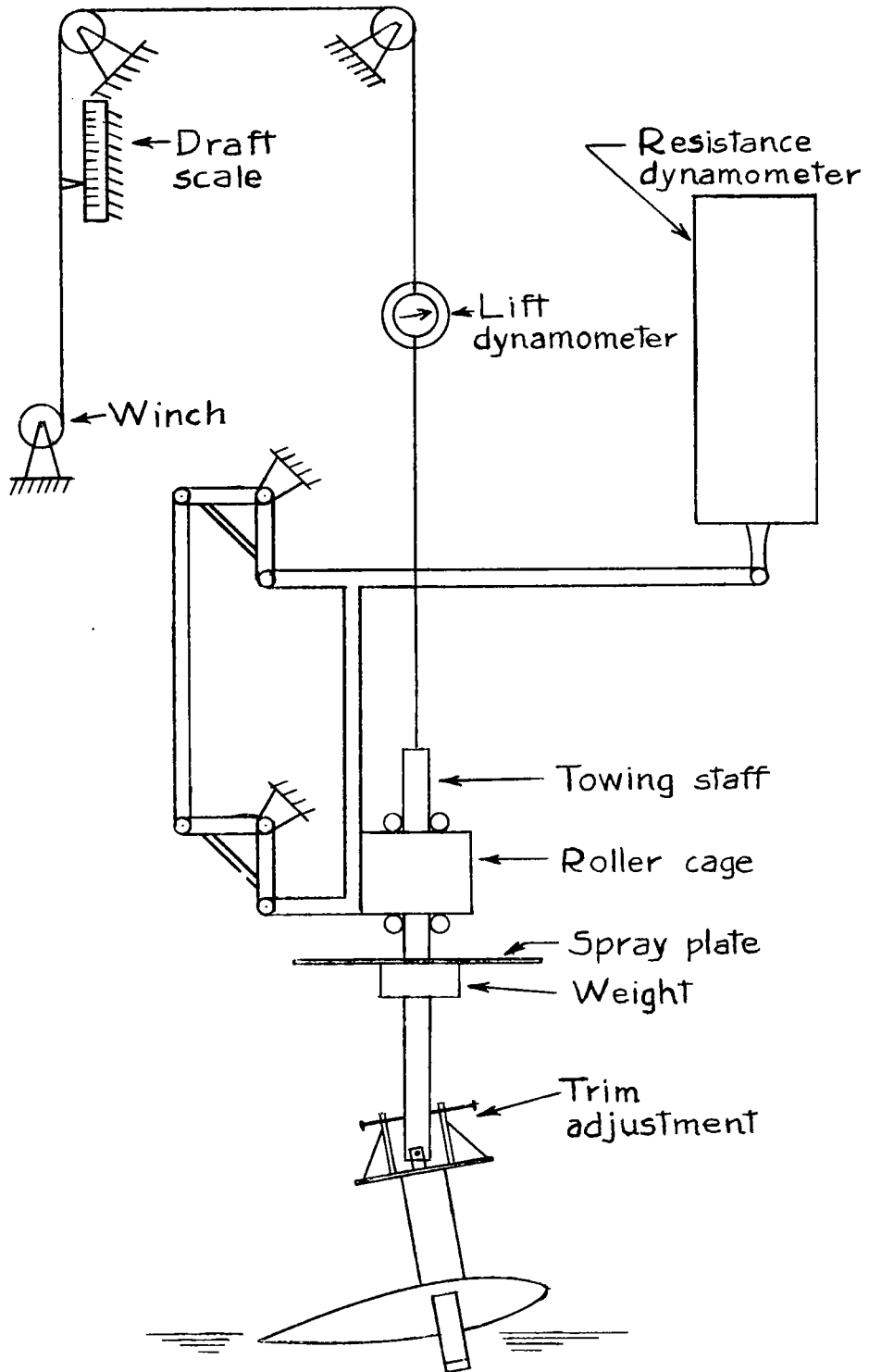

Figure 2.- Diagrammatic sketch of towing gear.

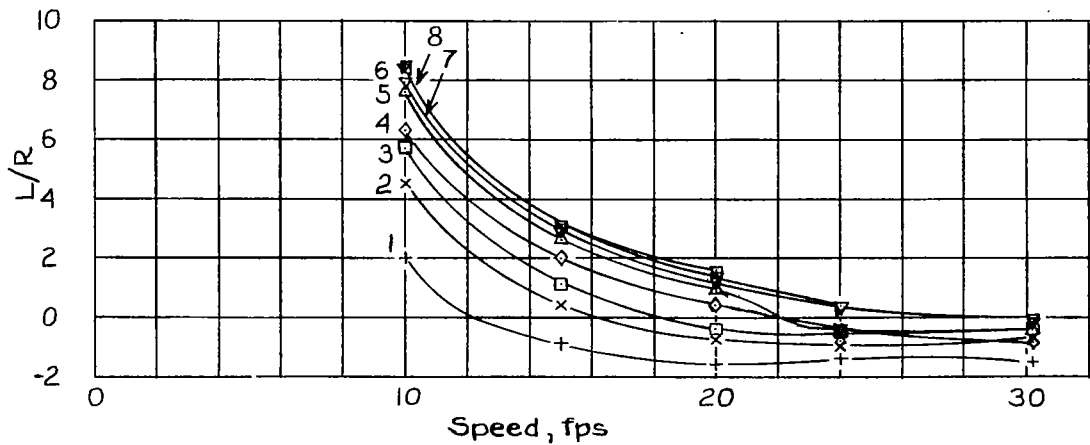
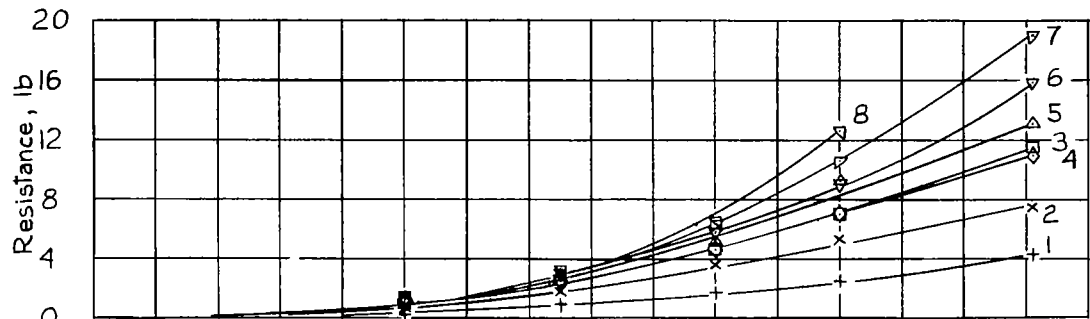
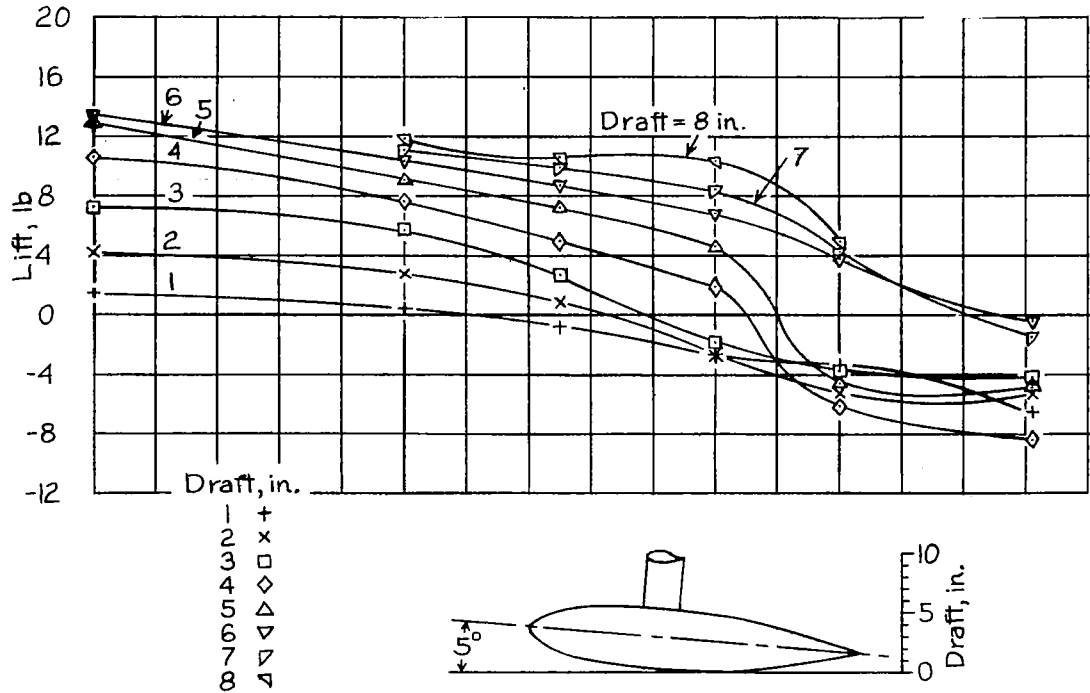

Figure 3.- Lift and resistance characteristics of streamline body. $\tau = 5^\circ$.

Fig. 4

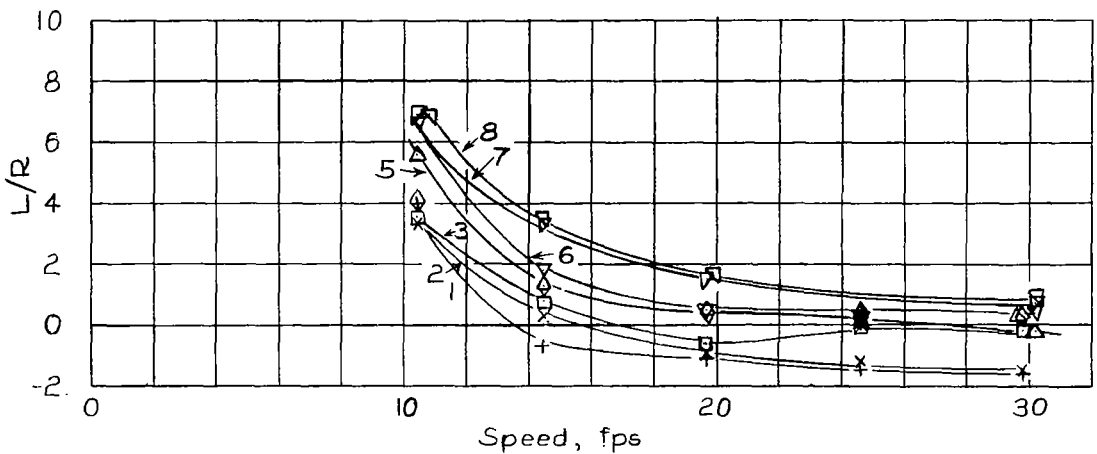
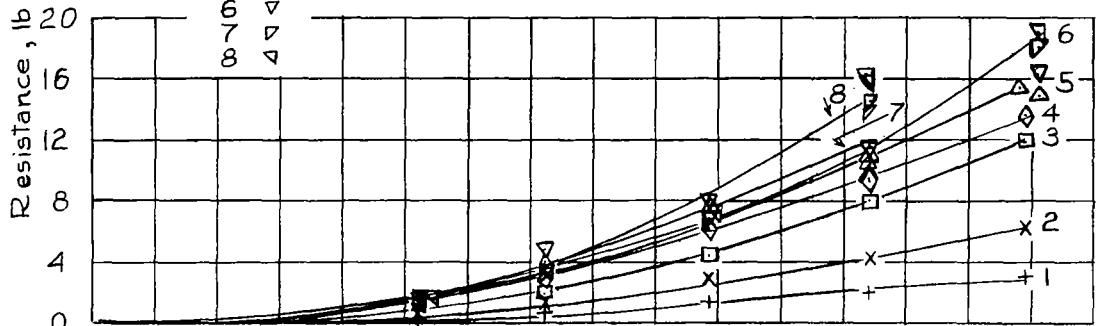
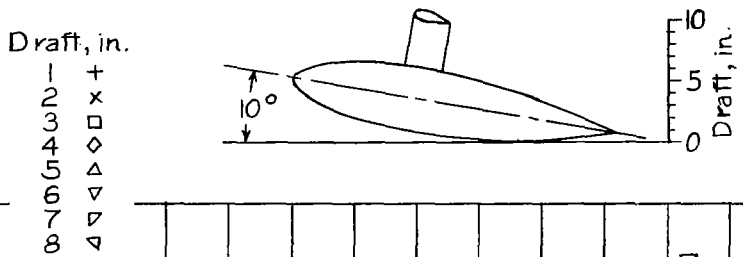
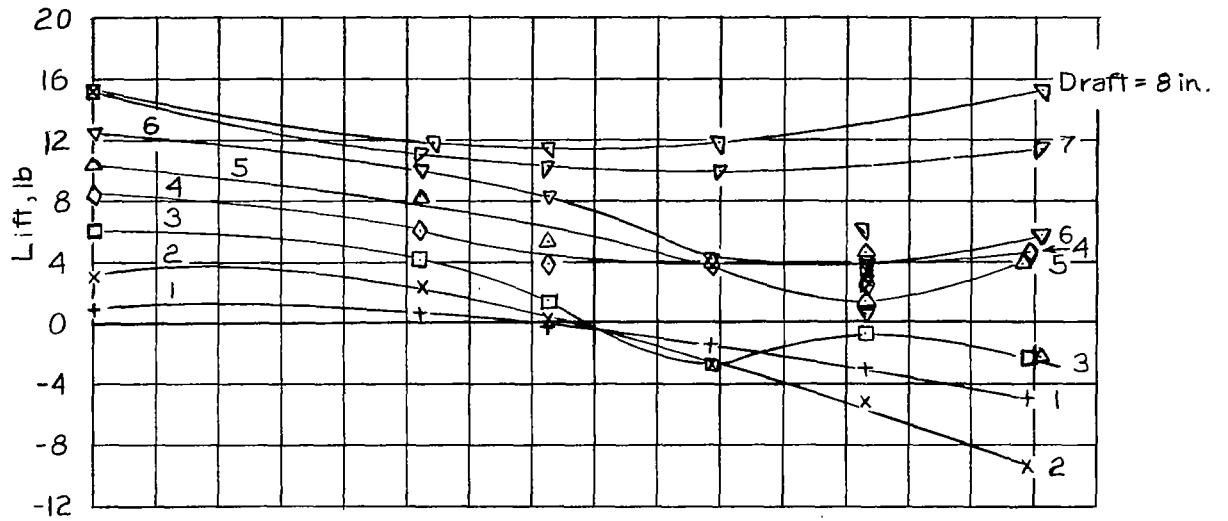

Figure 4.- Lift and resistance characteristics of streamline body. $\tau = 10^\circ$.

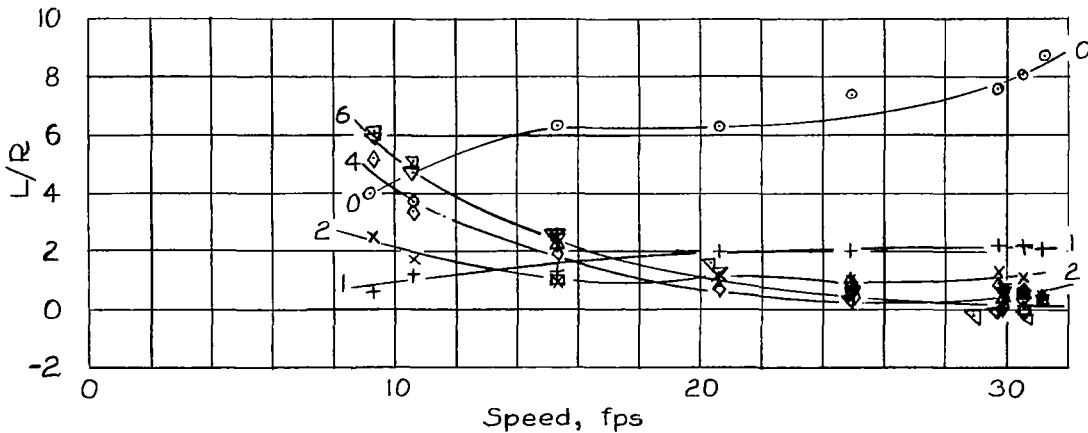
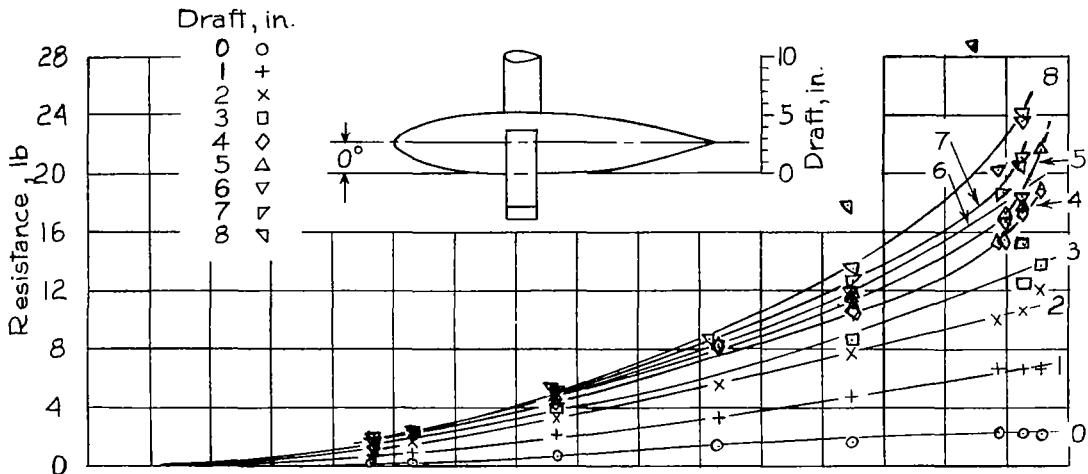
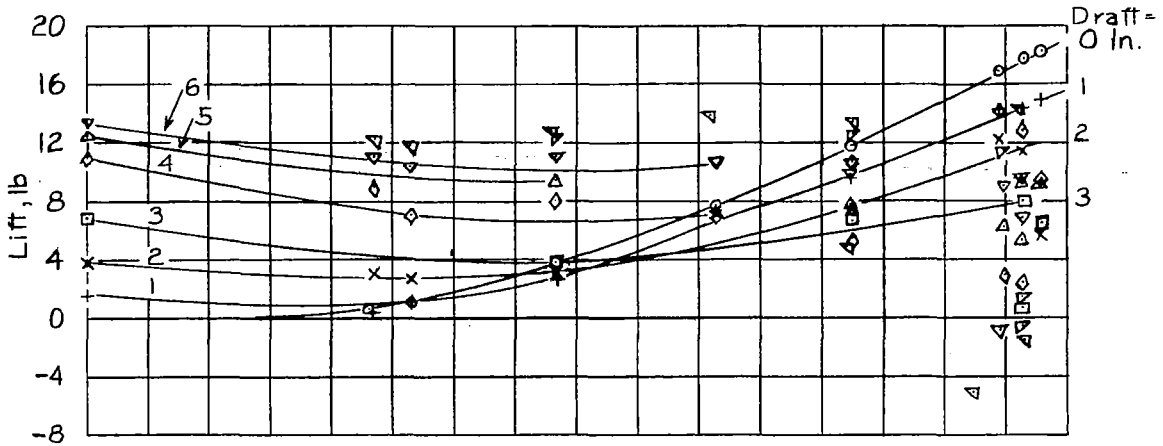

Figure 5.- Lift and resistance characteristics of streamline body with hydrofoil. $\tau = 0^\circ$.

Fig. 6

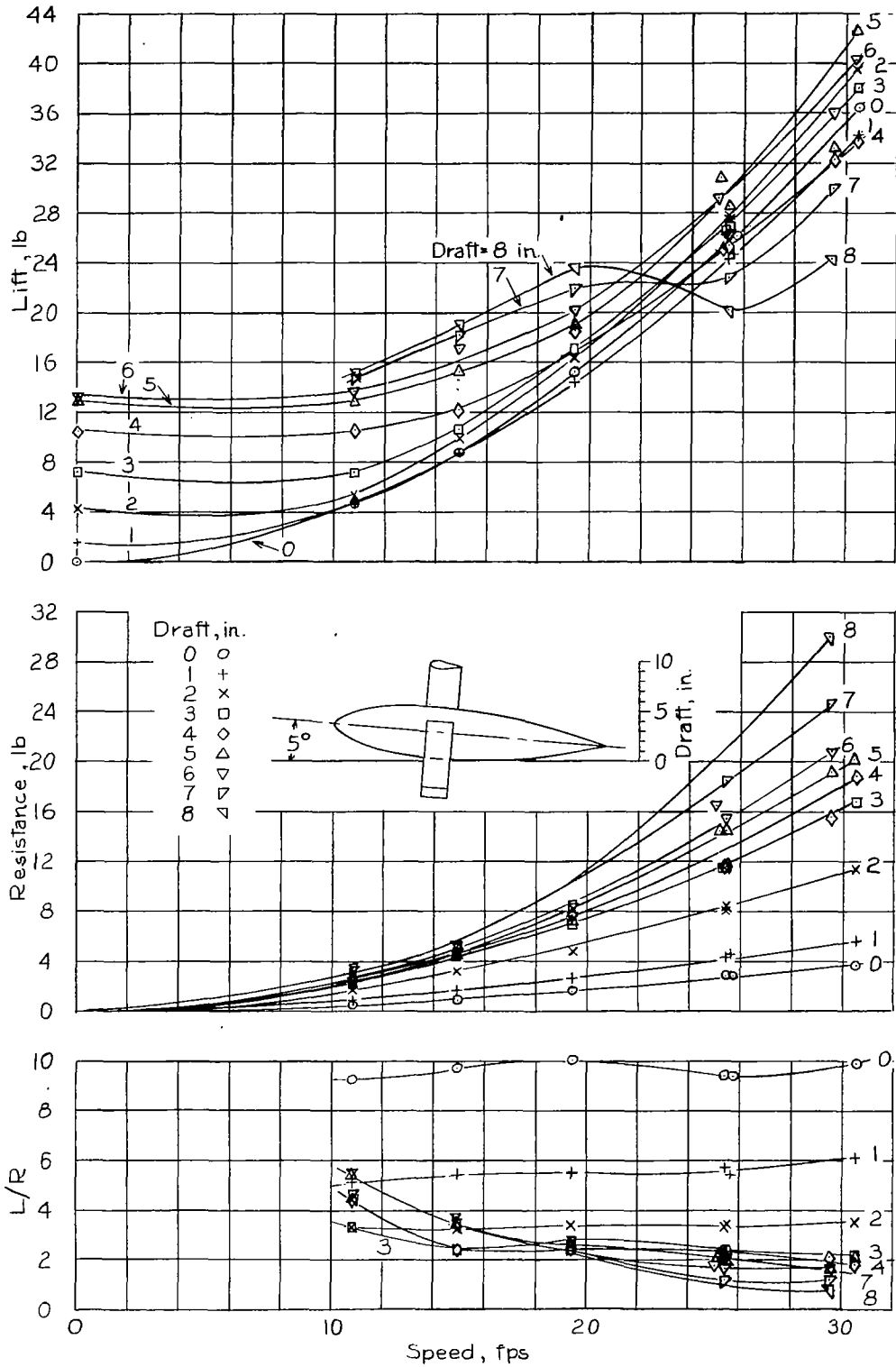

Figure 6.- Lift and resistance characteristics of streamline body with hydrofoil. $\tau = 5^\circ$.

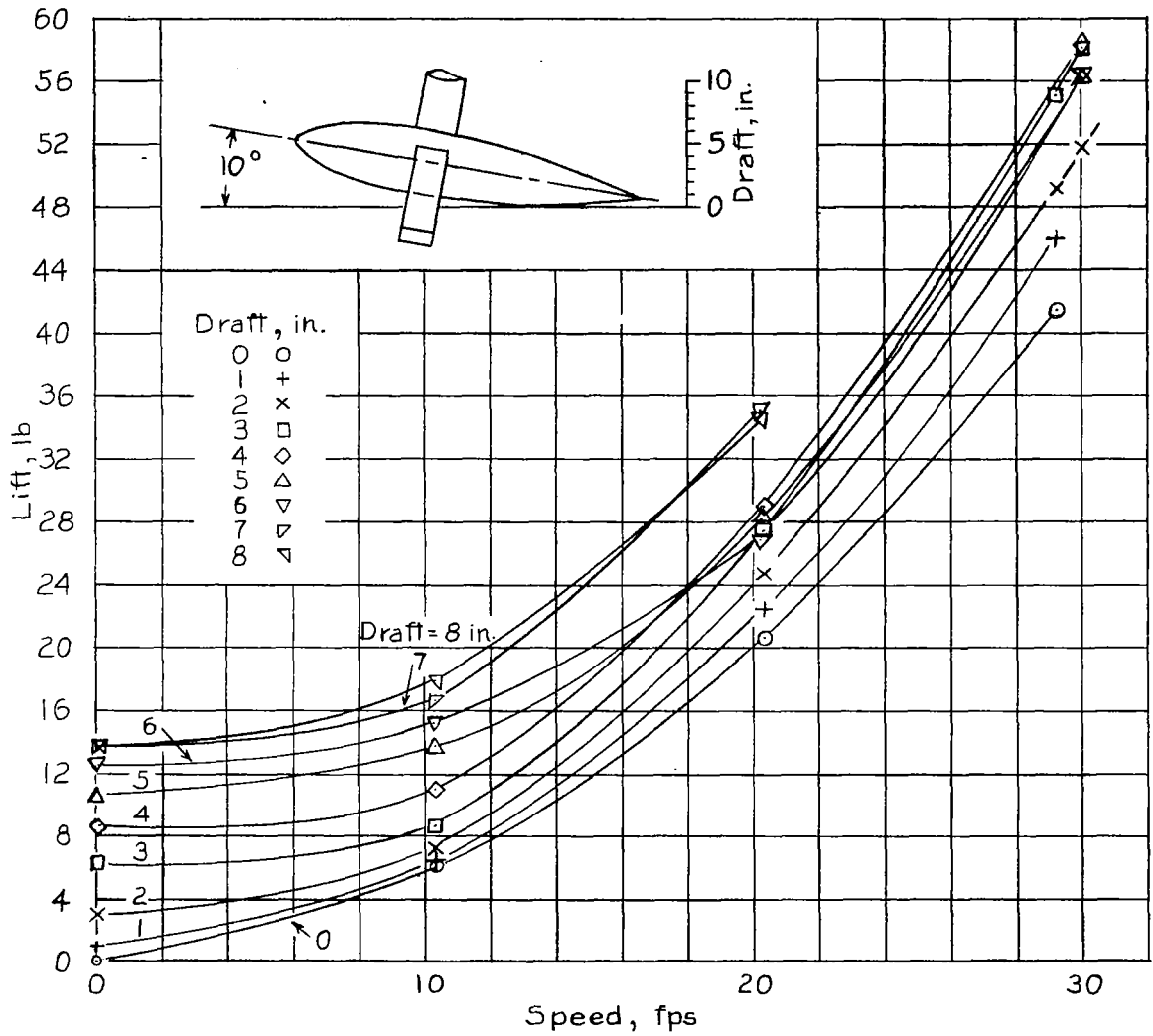

Figure 7.- Lift and resistance characteristics of streamline body with hydrofoil. $\tau = 10^\circ$.

Fig. 7b

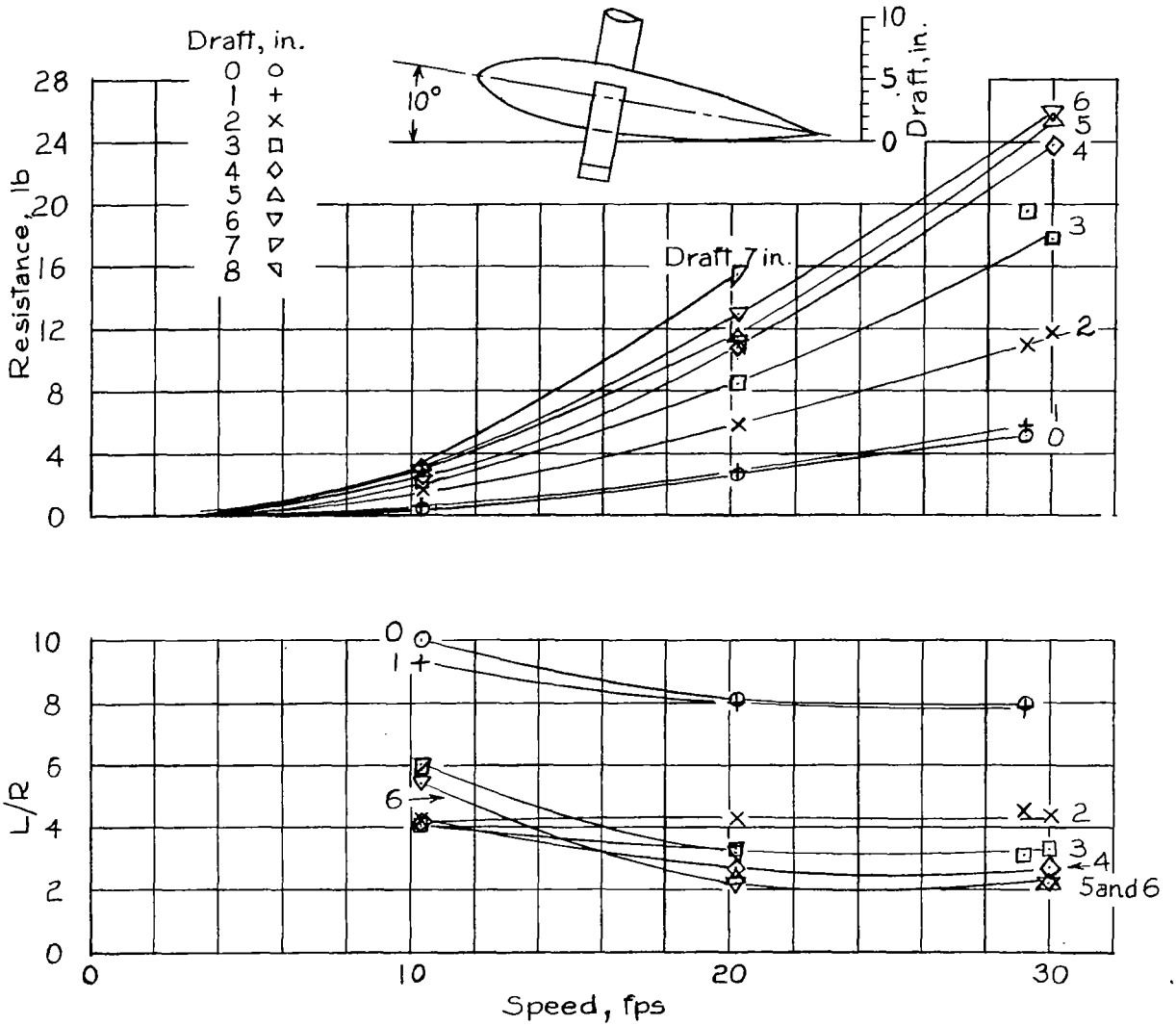

Figure 7. - Concluded.

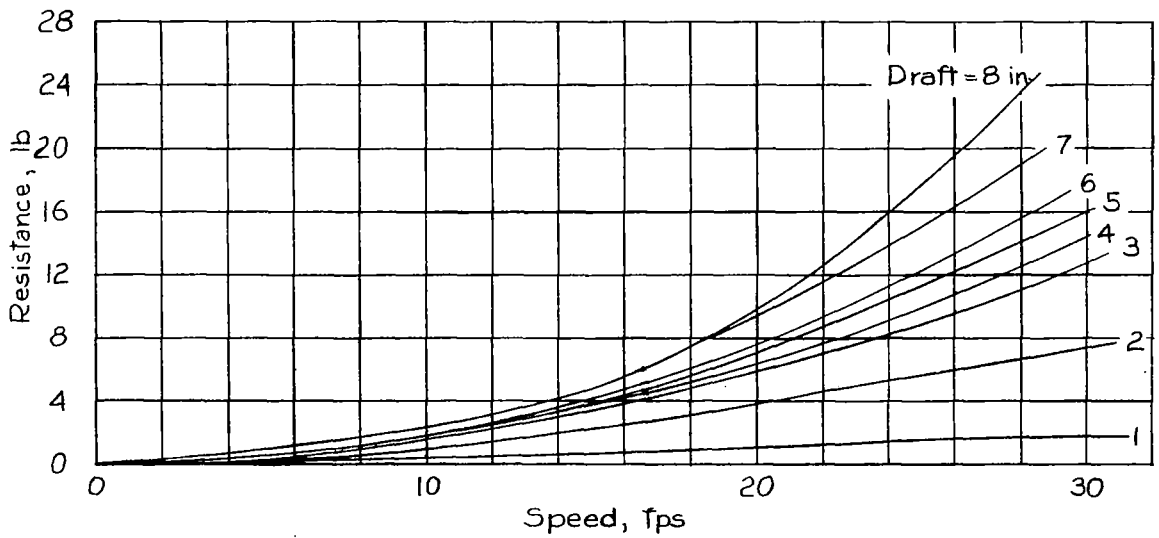
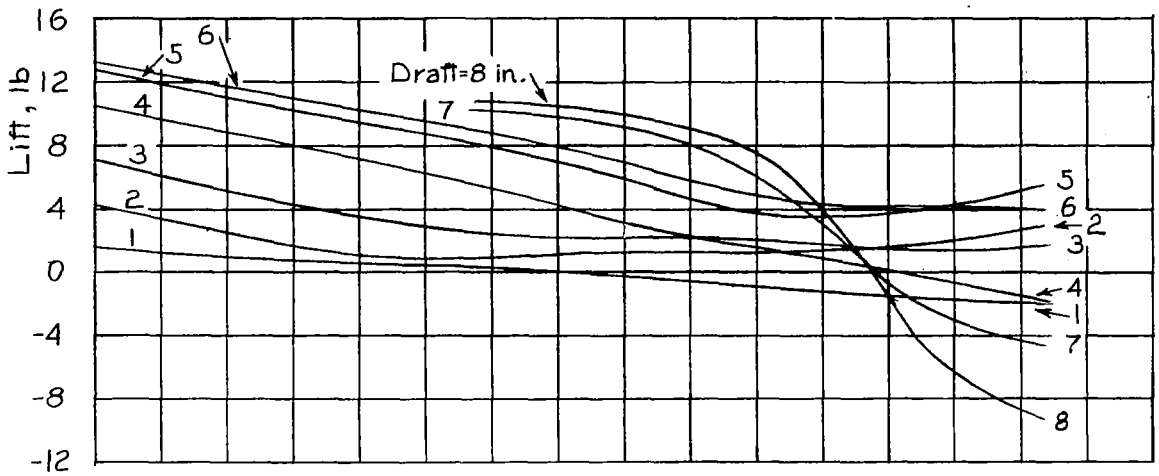

Figure 8.- Effective lift and resistance characteristics of streamline body. $\tau = 5^\circ$.

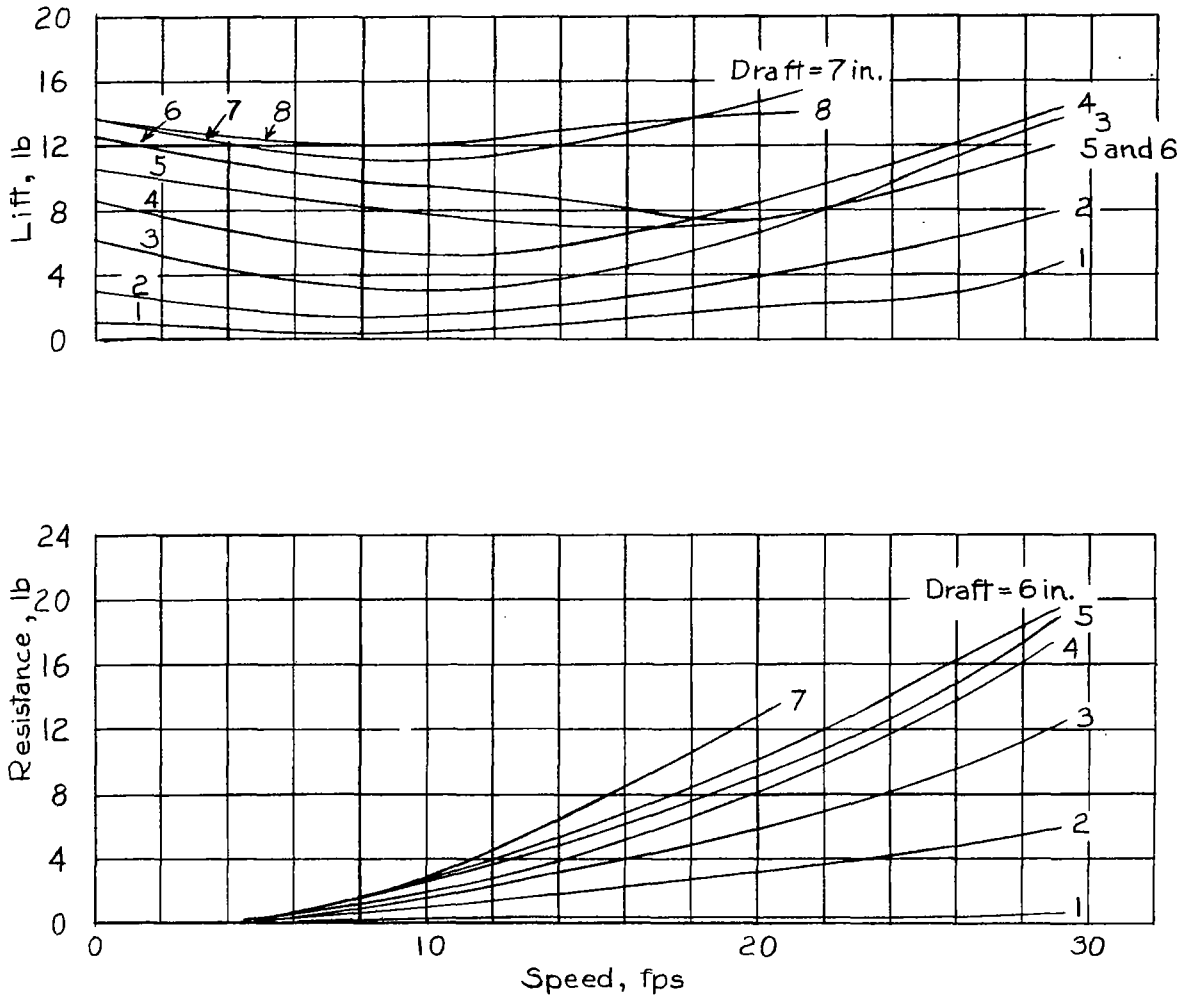

Figure 9.- Effective lift and resistance characteristics of streamline body. $\tau = 10^\circ$.

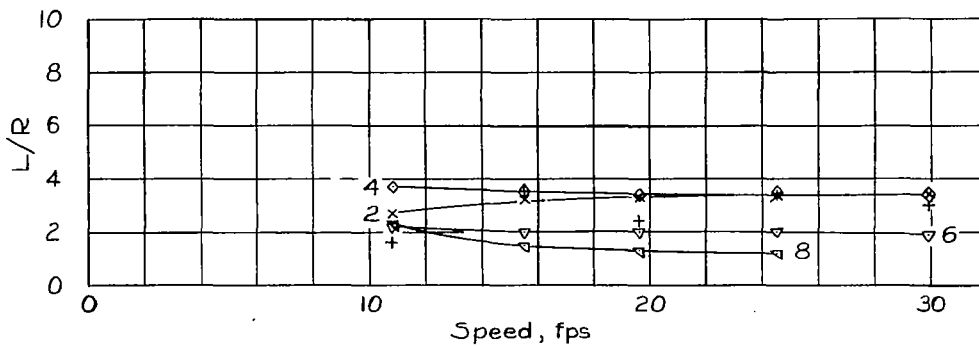
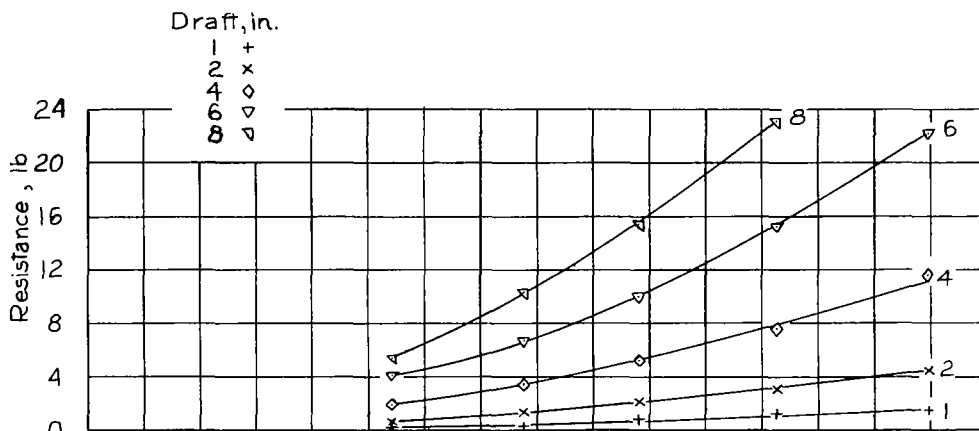
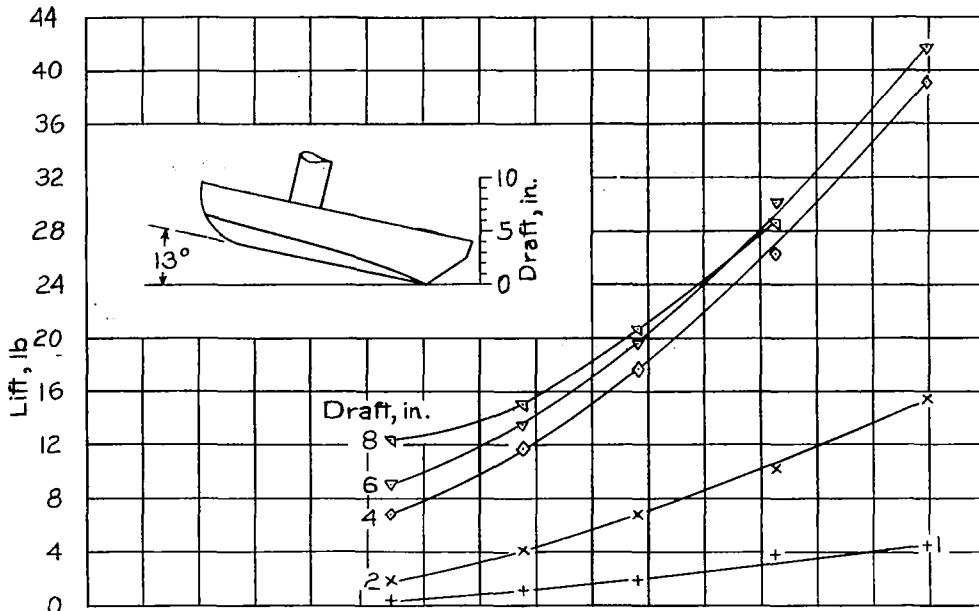

Figure 10.- Lift and resistance characteristics of $\frac{1}{5}$ -size model of PBV-type outboard float, NACA model 104-A; trim = 13°. (Data taken from unpublished tests.)

LANGLEY RESEARCH CENTER



3 1176 01365 5650