

MR No. E6G25

U.S. GOVERNMENT PRINTING OFFICE: 1946

NATIONAL ADVISORY COMMITTEE FOR AERONAUTICS

WARTIME REPORT

ORIGINALLY ISSUED

August 1946 as
Memorandum Report E6G25

AIR-FLOW AND PERFORMANCE CHARACTERISTICS OF ENGINE-STAGE
SUPERCHARGER OF A DOUBLE-ROW RADIAL AIRCRAFT ENGINE

II - EFFECT OF DESIGN VARIABLES

By Edmund J. Baas and Paul D. Dugan

Aircraft Engine Research Laboratory
Cleveland, Ohio



NACA

WASHINGTON

NACA WARTIME REPORTS are reprints of papers originally issued to provide rapid distribution of advance research results to an authorized group requiring them for the war effort. They were previously held under a security status but are now unclassified. Some of these reports were not technically edited. All have been reproduced without change in order to expedite general distribution.

E-285

NACA MR No. E6G25

NACA AIRCRAFT ENGINE RESEARCH LABORATORY

MEMORANDUM REPORT

for the

Air Materiel Command, Army Air Forces

AIR-FLOW AND PERFORMANCE CHARACTERISTICS OF ENGINE-STAGE
SUPERCHARGER OF A DOUBLE-ROW RADIAL AIRCRAFT ENGINE

II - EFFECT OF DESIGN VARIABLES

By Edmund J. Baas and Paul D. Dugan

SUMMARY

An investigation has been conducted to determine the effect of the location of the diffuser vanes with respect to the supercharger outlets and the effect of flow conditions at the impeller inlet on the air-flow distribution in the outlets of the engine-stage supercharger of an 18-cylinder double-row radial aircraft engine. The standard 13-vane diffuser rotated 180° from its original position and an NACA designed 18-vane diffuser were used to determine the effect of the diffuser-vane location with respect to the supercharger outlets. The 18 vanes of the diffuser correspond to the 18 outlets of the supercharger. The effect of flow conditions at the impeller inlet was investigated by distorting the flow at the inlet and noting the effect in the supercharger outlets. An NACA vaneless diffuser was used in this investigation to eliminate the diffuser-vane effect.

The results of the diffuser-vane investigation showed a slight change in distribution pattern when the 13-vane diffuser was rotated 180° . A marked improvement occurred in the distribution pattern when the NACA designed 18-vane diffuser was used. The inlet investigation showed that an appreciable change in the inlet-flow conditions caused a marked change in the distribution pattern. The distribution pattern of the 18 outlets of the supercharger is a summation of both the asymmetry between the diffuser vane and the supercharger outlet and the poor flow conditions at the impeller inlet. Because the flow in each outlet pipe is steady rather than intermittent as in actual engine operation, the maldistribution observed is greater than would be obtained in an engine-supercharger combination.

INTRODUCTION

As part of an investigation requested by the Air Materiel Command, Army Air Forces, to improve the mixture distribution of an 18-cylinder double-row radial aircraft engine, an extensive research program has been conducted at the NACA Cleveland laboratory to determine the air-flow characteristics of this engine.

In order to obtain uniform fuel-air ratio distribution among the cylinders of a radial aircraft engine and to obtain a uniform head-temperature pattern, the flow distribution at the outlets of the supercharger should be uniform. The unsatisfactory flow distribution in the 18 outlets of the engine-stage supercharger of this engine reported in reference 1 was not appreciably altered by a change in speed, volume flow, carburetor-throttle angle, or outlet pressure. The analysis of the causes for this poor distribution indicated that it was possibly due to: (a) the asymmetrical relation between the diffuser vanes and the supercharger outlets caused by use of 13 diffuser vanes and 18 supercharger outlets and (b) a poor velocity profile of the air at the impeller entrance.

The effect of an asymmetrical relation between the diffuser vanes and the supercharger outlets was determined in runs made at 2000 and 2400 rpm with the standard 13-vane diffuser rotated 180°. This rotation of the diffuser shifted the location of each vane with respect to an outlet to a diametrically opposite outlet. The runs were repeated with an NACA designed 18-vane diffuser, which eliminated the diffuser-vane supercharger-outlet asymmetry. The 18 vanes of the diffuser correspond to the 18 outlets of the supercharger. The effect of the velocity profile of the air at the impeller entrance on the air-flow distribution of the supercharger outlets was investigated by creating a large distortion of the air at the impeller inlet by blocking off a portion of the area at the elbow inlet. A vaneless diffuser was used to eliminate any diffuser-vane effect. Improving the flow through the elbow was considered impractical in the present investigation because of the small axial length available.

APPARATUS AND TEST PROCEDURE

The complete engine-stage supercharger and accessory drive assembly was set up with 18 uniform supercharger-outlet pipes, as shown in figure 1. The complete setup, the methods of investigation, and the calculations are described in reference 1. Unless otherwise specified all series of runs reported herein were made at a reference outlet pressure of 6 inches of mercury above atmospheric and full-open carburetor-throttle angle of 66°.

Two series of runs were made to determine the effect of the relation between the diffuser vanes and the supercharger outlets. For the first series, the standard 13-vane diffuser was rotated 180° and runs were made at engine speeds of 2000 and 2400 rpm. The change in vane location is shown in figure 2. For the second series, an NACA designed 18-vane diffuser was installed. The method of design is given in the appendix and a sketch of the diffuser and of the relation of the vanes and the supercharger outlets is shown in figure 3. Runs with the 18-vane diffuser were made at engine speeds of 1800, 2000, 2200, 2400, and 2600 rpm over the complete flow range. In reference 1, it was found that changing either the carburetor-throttle angle or the reference outlet pressure had little effect on the air-distribution pattern. Check runs were made with the 18-vane diffuser for these operating variables at carburetor-throttle angles of 40° and 50° at engine speeds of 2000 and 2400 rpm and at reference outlet pressures of 10 and 3 inches of mercury gage at 2400 rpm and 3 inches of mercury gage at 2000 rpm. The pressure rise was insufficient to obtain a reference outlet pressure of 10 inches of mercury gage at 2000 rpm.

In order to determine the effect of the velocity profile at the impeller inlet on the distribution at the supercharger outlets, runs were made with a large distortion of the velocity profile. Improving the flow by redesigning the inlet elbow was impractical because of the small axial length available. A splitter vane and a distortion plate were installed in the inlet elbow to divide the elbow into two separate passages and to block off approximately one-fourth the total inlet area at the inside of the bend, respectively. (See fig. 4.) Runs were made at 2000 rpm with a vaneless diffuser to eliminate the effect of the diffuser vanes. The runs were then repeated without the splitter vane and the distortion plate.

RESULTS AND DISCUSSION

The air-distribution data are presented as nondimensional plots of M/M_a against supercharger-outlet-pipe number, where M is the measured mass flow in any one pipe and M_a is the computed average mass flow for one pipe. The outlet-pipe number corresponds to the engine-cylinder number.

Diffuser Effect

Standard diffuser rotated 180° . - The air-flow distribution in the supercharger outlets with the standard 13-vane diffuser in its original position (reference 1) and rotated 180° from this position

is plotted in figure 5. These results are presented at two volume flows for engine speeds of 2000 and 2400 rpm. The comparative plots are made at approximately equal values of the flow function $Q_{2t}/\sqrt{T_{2t}}$, where Q_{2t} is the fictitious total volume flow in the supercharger outlets and T_{2t} is the total temperature at the same location. This flow function is discussed in reference 1.

The relative location of any one vane with respect to the outlet is shifted to a diametrically opposite outlet (fig. 2) by a 180° rotation of the diffuser. Theoretically, if the diffuser vanes have the predominate influence on the air-flow distribution at the supercharger outlets, the distribution pattern should be shifted 180° with a 180° rotation of the diffuser. A definite shift in the distribution pattern resulted but did not correspond to a shift of 180° . The low-flow region remained in outlets 13 to 14 indicating that, in addition to the diffuser effect, the air-flow pattern at the impeller inlet affects the distribution.

NACA 18-vane diffuser. - The distribution pattern of the NACA 18-vane diffuser is compared with that of the standard 13-vane diffuser in figure 6 for two representative values of $Q_{2t}/\sqrt{T_{2t}}$ at engine speeds of 2000 and 2400 rpm, respectively. The 18-vane diffuser reduced the flow in the high-flow outlet pipes and increased the flow in the low-flow outlet pipes, which resulted in a marked improvement in the distribution among the supercharger outlets. The air flow with the 13-vane diffuser varied from about 30 percent above to about 50 percent below the average flow, whereas the air flow with the 18-vane diffuser varied from about 20 percent above to 20 percent below the average flow. This reduction of about one-half the original spread attained with the 18-vane diffuser clearly indicates that the asymmetrical relation between the 13-vane diffuser and the supercharger outlets is responsible for a large amount of the maldistribution. The remaining spread, however, indicates that the velocity profile at the impeller inlet also causes a sizable variation in the air-flow distribution.

Because the 18-vane diffuser effected a large improvement in air-flow distribution the supercharger performance was checked for various engine speeds, carburetor-throttle angles, and reference outlet pressures. The air-flow distribution, at approximately constant volume flows, was shown in figures 7 to 9 to be unaffected by changes in these operating variables. Figure 10 presents a comparison of the supercharger performance obtained with the 18-vane diffuser and with the 13-vane diffuser. The values presented on the supercharger-performance curve are wholly comparable because the test rig was not lagged. No appreciable changes occurred in the supercharger performance except that the operating range of the supercharger was shifted to higher

flows with the 18-vane diffuser. Although the 18-vane diffuser was responsible for the over-all improvement in the air-flow distribution at the supercharger outlet, the change in operating range of the diffuser indicated that this diffuser did not quite match the peak operating point of the impeller. A lack of data prevented a correct determination of conditions at the impeller outlet. If more nearly correct conditions at the impeller outlet were assumed, the diffuser could be redesigned to match the impeller as well as to obtain the same good distribution performance.

Inlet Effect

The results of the investigation of the effect of the velocity profile of the air at the impeller inlet on the air-flow distribution at the supercharger outlet are shown in figure 11, which is a comparison of the distribution at the supercharger outlet using a vaneless diffuser with and without the splitter vane and distortion plate. With these modifications, the flow in pipes 12 to 18 was greatly increased and the flow in pipes 2, 3, 4, and 10 was decreased. The velocity profile at the impeller inlet apparently has a marked effect on the air-flow distribution among the supercharger outlets. At least part of the maldistribution not corrected by the 18-vane diffuser is therefore due to a nonuniform velocity profile at the outlet of the supercharger inlet elbow. A redesign of the inlet elbow for this investigation was not feasible because of the severe axial length limitation in the rear section of the engine.

GENERAL COMMENTS

The nonuniform air-flow distribution at the outlets of the standard supercharger is mainly a combined result of a poor velocity distribution at the inlet to the impeller and an asymmetrical location of the diffuser vanes with respect to the supercharger outlets. In order to obtain a good flow distribution at the impeller inlet, the rear supercharger housing would have to be redesigned. The 18-vane diffuser, however, showed that an appreciable improvement could be obtained by eliminating the asymmetry of the diffuser-vane location with respect to the supercharger outlets. Although the 18-vane diffuser did not match the peak operating point of the impeller, this diffuser could be redesigned to match the operating range of the impeller and retain the improved distribution pattern.

SUMMARY OF RESULTS

The following results were obtained from the investigation of the effect of the location of the diffuser vanes with respect to the supercharger outlets and the effect of the flow conditions at the impeller inlet on the air-flow distribution in the outlets of the engine-stage supercharger of the 18-cylinder double-row radial aircraft engine.

1. The asymmetrical location of the supercharger diffuser vanes with respect to the supercharger outlets had a definite effect on the flow distribution in the outlets. A slight change in the distribution pattern was shown when the standard 13-vane diffuser was rotated 180°. The NACA 18-vane diffuser showed that elimination of the diffuser-vane supercharger-outlet asymmetry would result in a definite improvement of the outlet flow distribution.

2. A large distortion of the flow at the impeller inlet caused a decided change in the distribution pattern in the outlets of the supercharger.

3. The poor distribution obtained with the standard supercharger installation appeared to be a summation of asymmetrical diffuser-vane location with respect to supercharger outlets and distorted flow at the impeller inlet.

Aircraft Engine Research Laboratory,
National Advisory Committee for Aeronautics,
Cleveland, Ohio.

APPENDIX - DESIGN THEORY OF NACA 18-VANE DIFFUSER

Assumptions. - The following assumptions of the design conditions of the NACA 18-vane diffuser were made:

Impeller adiabatic efficiency, η_{ad}	0.85
Slip factor	0.9
Weight flow of air, lb/hr	14,150
Engine speed, rpm	2400
Impeller tip speed, ft/sec	828
Carburetor upper-deck static pressure, P_{os} , in. Hg	30
Carburetor upper-deck static temperature, T_{os} , $^{\circ}F$	100
Carburetor pressure drop, ΔP_C , in. Hg	4.2

Method of design. - The vane profile was determined by using the infinite-vane theory and computing the flow path of the air when 50 percent of the rotation was removed according to the following diagram. The amount of rotation is defined as $V_{\theta r}$ where V_{θ} is the tangential velocity and r , the radius of the diffuser.

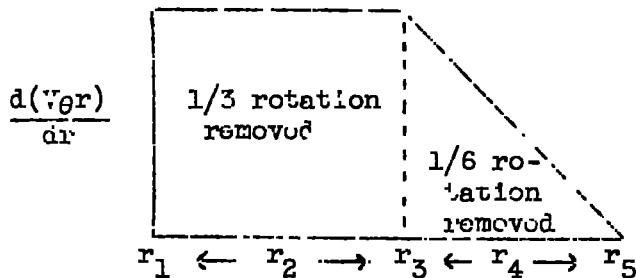

The various radii are defined by the following subscripts affixed to r :

- 1 diffuser inlet
- 2 any station between 1 and 3
- 3 station half way between 1 and 5
- 4 any station between 3 and 5
- 5 diffuser outlet

The tangential velocity $V_{\theta 1}$, the radial velocity V_r , and the resultant velocity V_1 were found at the inlet to the diffuser from the inlet conditions, the supercharger performance, and the carburetor pressure drop.

The tangential component of velocity V_{θ} for radii from r_1 to r_3 was found by determining the linear relation of V_{θ} and r . For any radius r_2

$$V_{\theta 2} = \frac{r_1}{r_2} V_{\theta 1} \left[1 - \frac{1}{3} \left(\frac{r_2 - r_1}{r_3 - r_1} \right) \right]$$

V_{θ} was determined for radii from r_3 to r_5 by the following method:

$$\left[\frac{d(V_{\theta}r)}{dr} \right]_4 (r_3 - r_1) = \frac{1}{3} V_{\theta 1} r_1$$

Write the equation for the linear variation in $\frac{d(V_{\theta}r)}{dr}$ from r_3 to r_5 as

$$Y = mr + b$$

and solve for m and b . Then, for any radius r_4 ,

$$V_{\theta 4} = \frac{2}{3} \frac{V_{\theta 1} r_1}{r_4} - \frac{V_{\theta 1} r_1}{3r_4 (r_3 - r_1) (r_5 - r_3)} \left[r_5 (r_4 - r_3) - \left(\frac{r_4^2}{2} - \frac{r_3^2}{2} \right) \right]$$

The equation for V was found at various radii through the diffuser by the following method:

$$\frac{\gamma}{\gamma - 1} \frac{P_{1s}}{\rho_{1s}} + \frac{V_1^2}{2} = \frac{\gamma}{\gamma - 1} \frac{P_s}{\rho_s} + \frac{V^2}{2}$$

where

P_s static pressure, lb/sq ft

γ ratio of specific heats

ρ density, slugs/cu ft

Assuming no loss through the diffuser,

$$P_s = \frac{P_{1s} \rho_s^\gamma}{\rho_{1s}^\gamma}$$

for a diffuser with parallel walls,

$$\rho_s = \frac{\rho_{1s} V_{1r} r_1}{V_r r}$$

Then

$$v^2 = \frac{2\gamma P_{1s}}{(\gamma - 1)\rho_{1s}} \left[1 - \left(\frac{V_{1r} r_1}{r \sqrt{v^2 - v_\theta^2}} \right)^{\gamma-1} \right] + v_1^2$$

This equation was solved by trial and error for various radii. The value of V_r at various radii was found from

$$V_r = \sqrt{v^2 - v_\theta^2}$$

The equation of V_r was determined by plotting V_r against r on logarithmic paper and measuring the slope of the curves. The general equation is

$$V_r = \frac{c}{r^k}$$

This procedure was followed for radii from r_1 to r_3 and from r_3 to r_5 .

The variation of displacement angle ϕ with radius was found from radii from r_1 to r_3 and r_3 to r_5

$$v_\theta = r \frac{d\phi}{dt}$$

$$V_r = \frac{dr}{dt}$$

Then

$$\frac{r d\phi}{v_\theta} = \frac{dr}{V_r}$$

This equation was solved for ϕ by substituting the equations of V_r and v_θ and integrating. The angle ϕ was then found for various radii and the results were plotted to obtain the shape of the vane, which was approximated by arcs of a circle.

REFERENCE

1. Baas, Edmund J., Monroe, William R., and Mesrobian, John M.: Air-Flow and Performance Characteristics of the Engine-Stage Supercharger of a Double-Row Radial Aircraft Engine. I - Effect of Operating Variables. NACA MR No. E5H28, 1945.

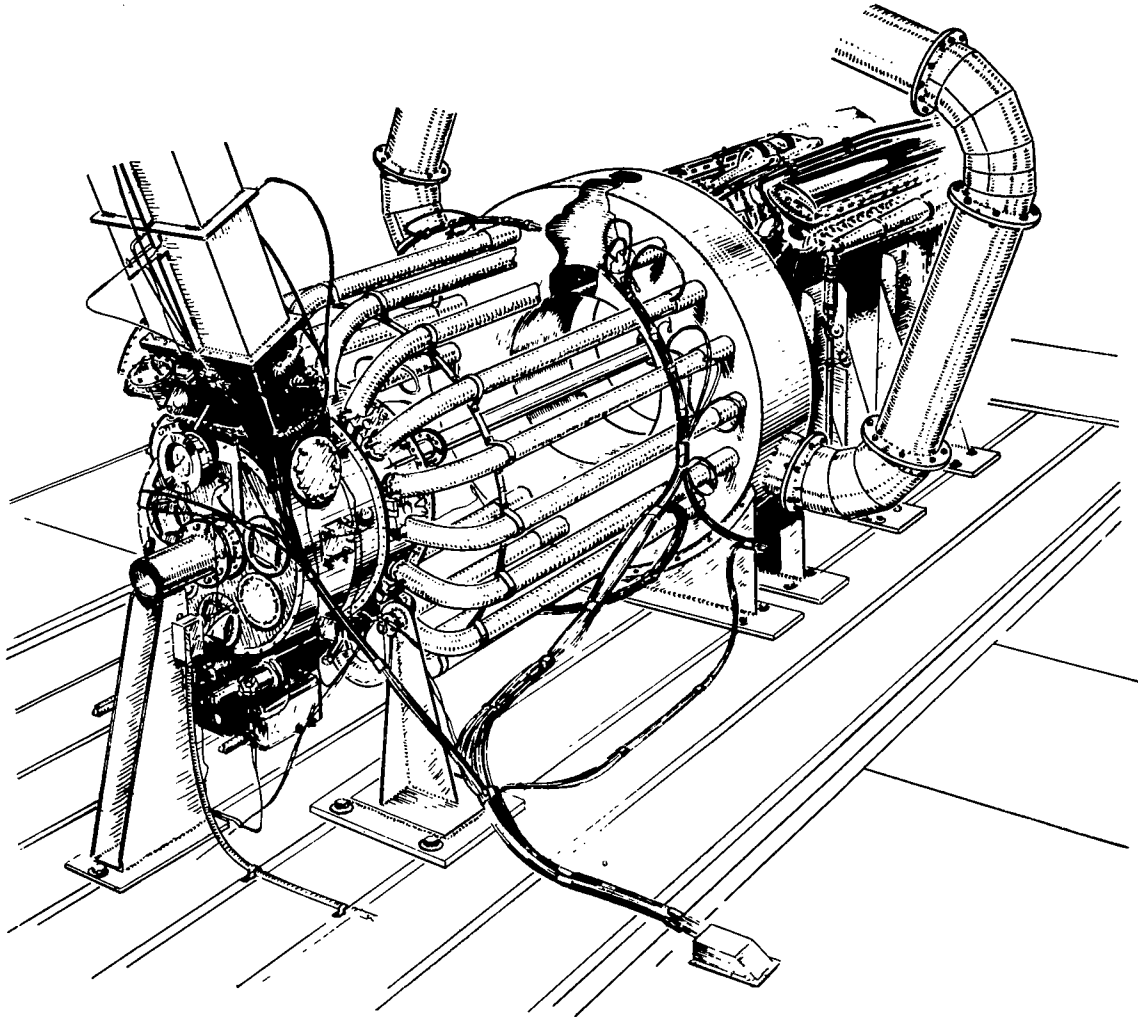

NATIONAL ADVISORY
COMMITTEE FOR AERONAUTICS

Figure 1. - Setup for
investigation.

supercharger air-distribution

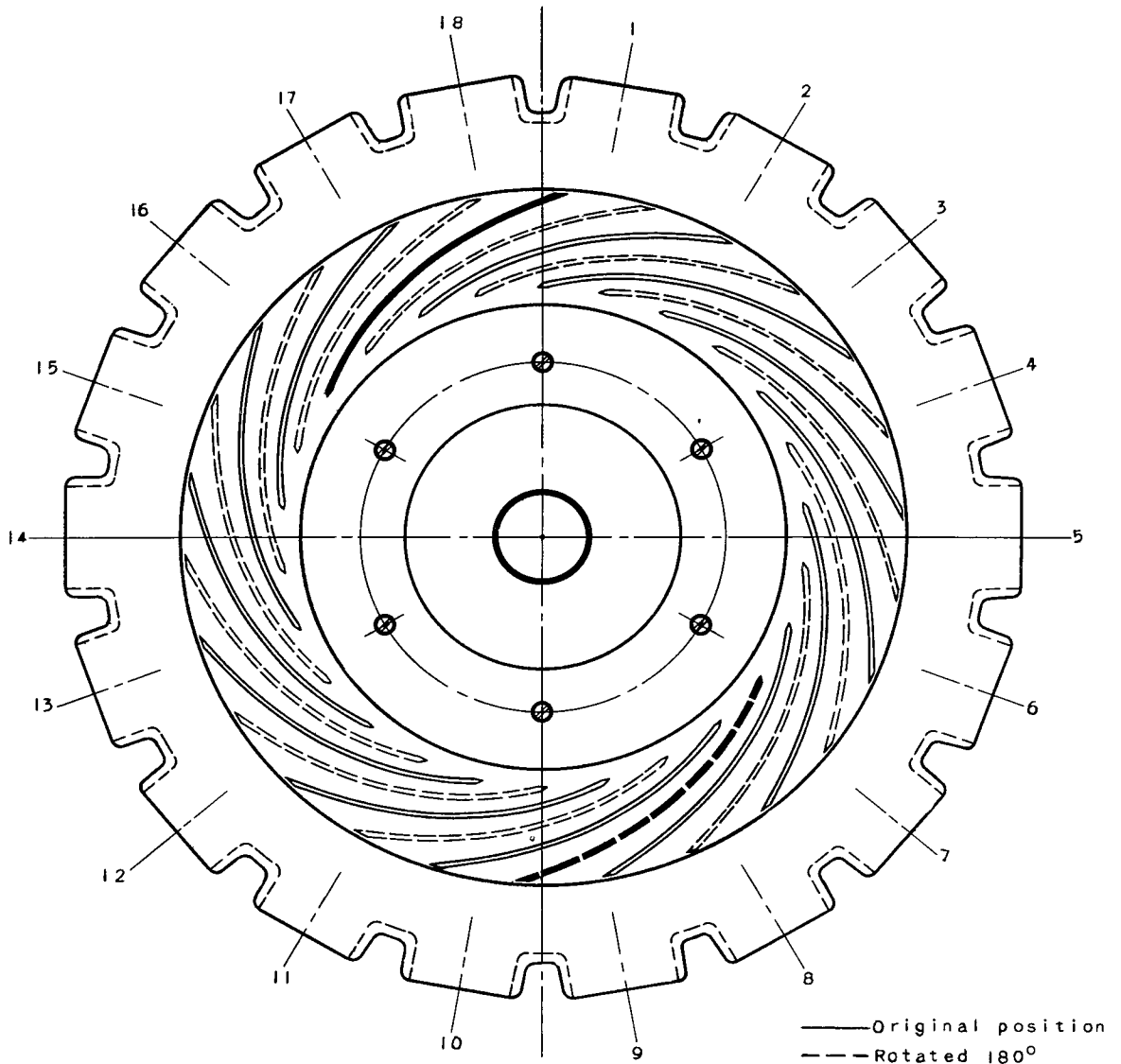

Figure 2. - Sketch of standard 13-vane diffuser in original position and rotated 180° showing relation of diffuser vanes and supercharger outlets.

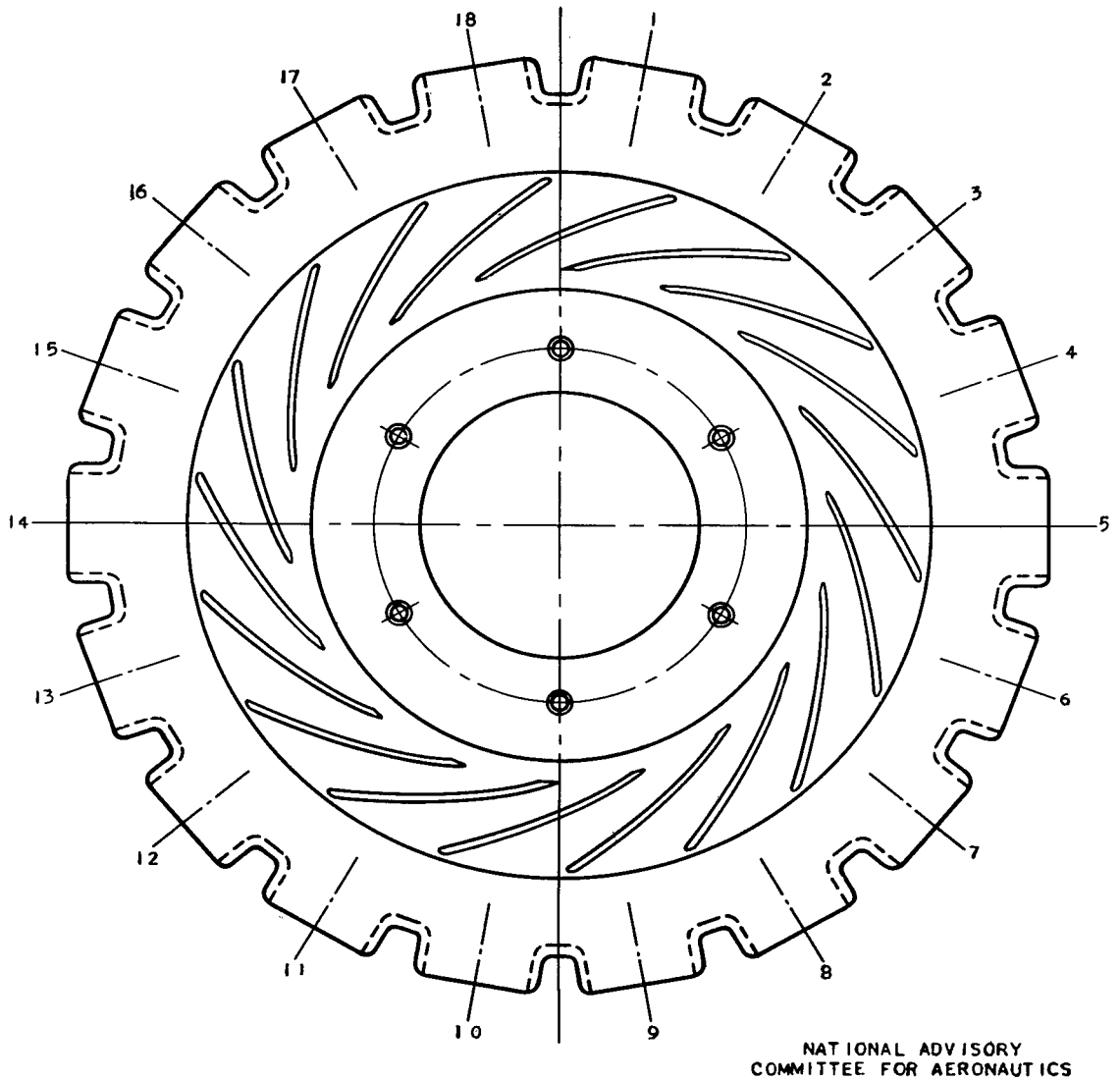
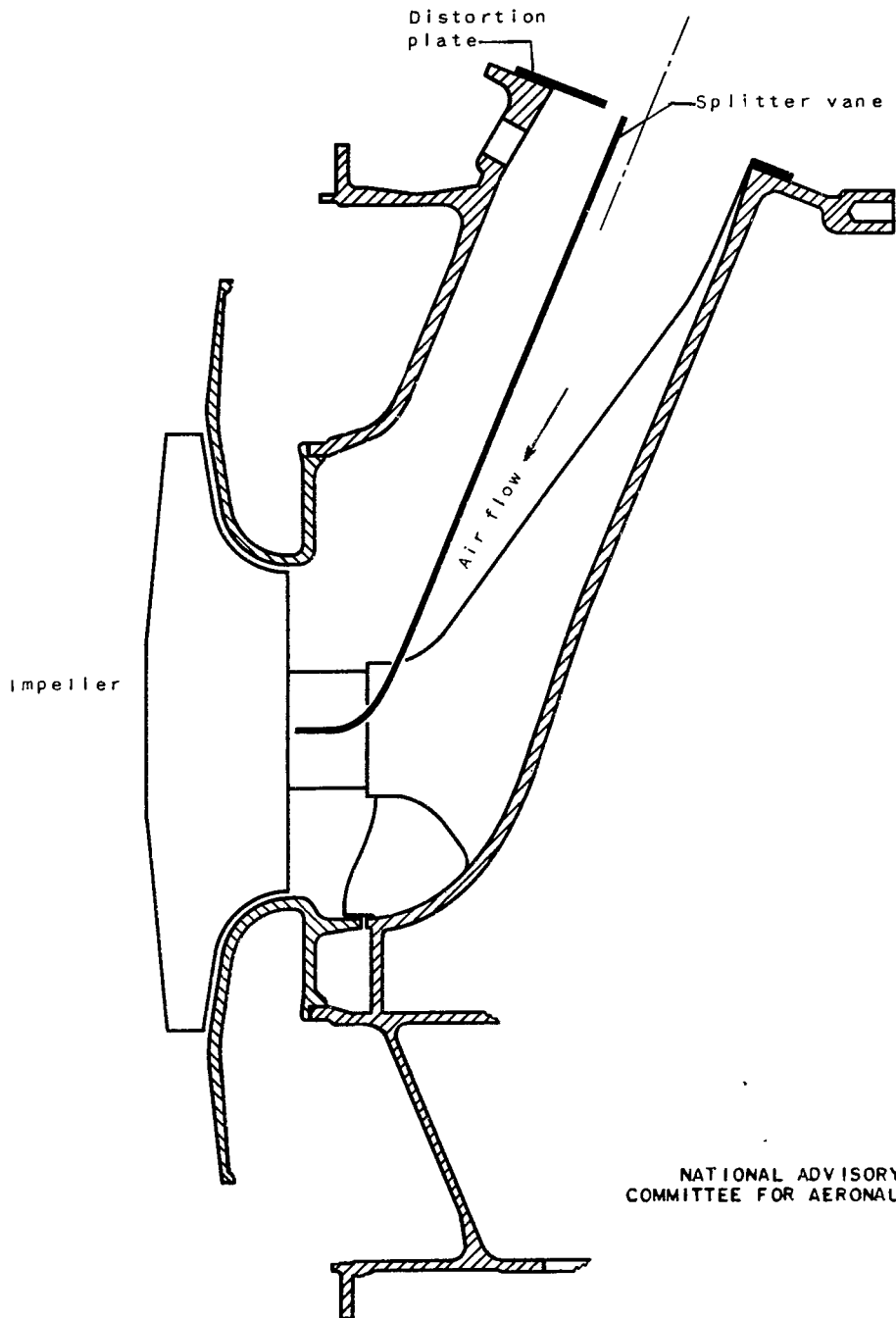

Figure 3. - Sketch of NACA 18-vane diffuser showing relation of diffuser vanes and supercharger outlets.



NATIONAL ADVISORY
COMMITTEE FOR AERONAUTICS

Figure 4. - Sketch of supercharger inlet elbow showing splitter vane and distortion plate.

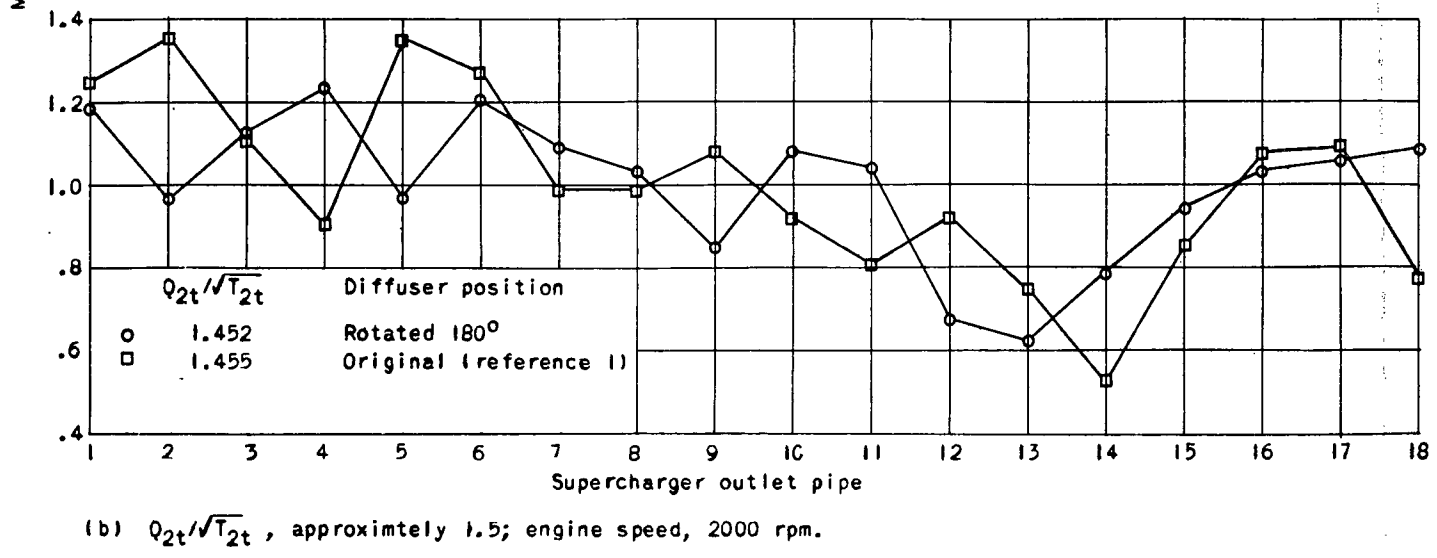
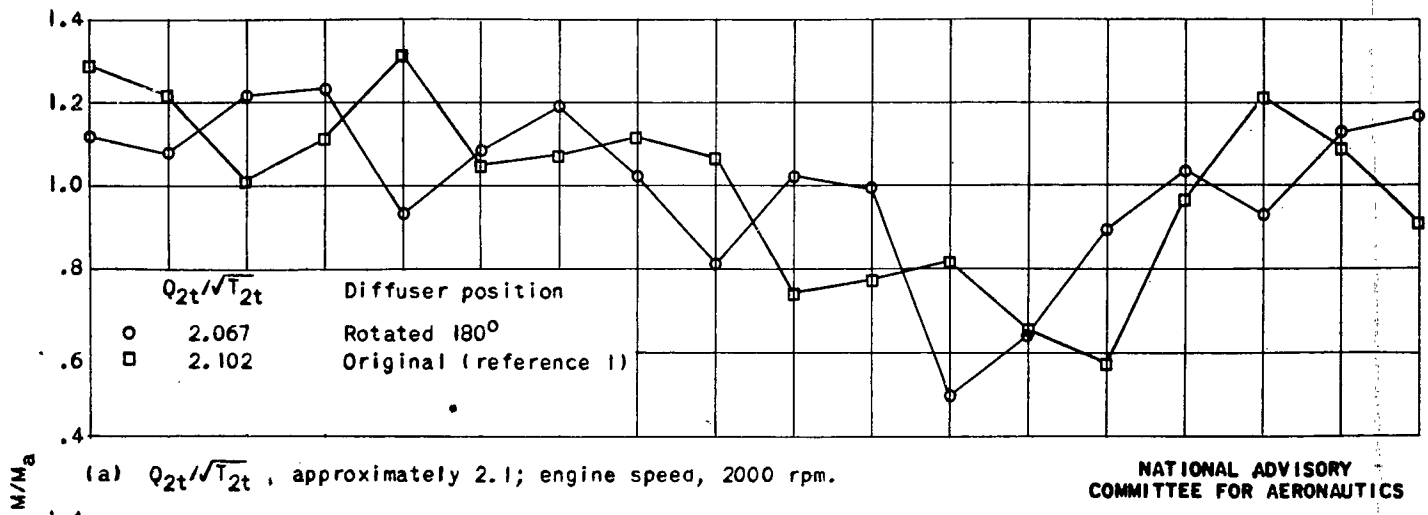
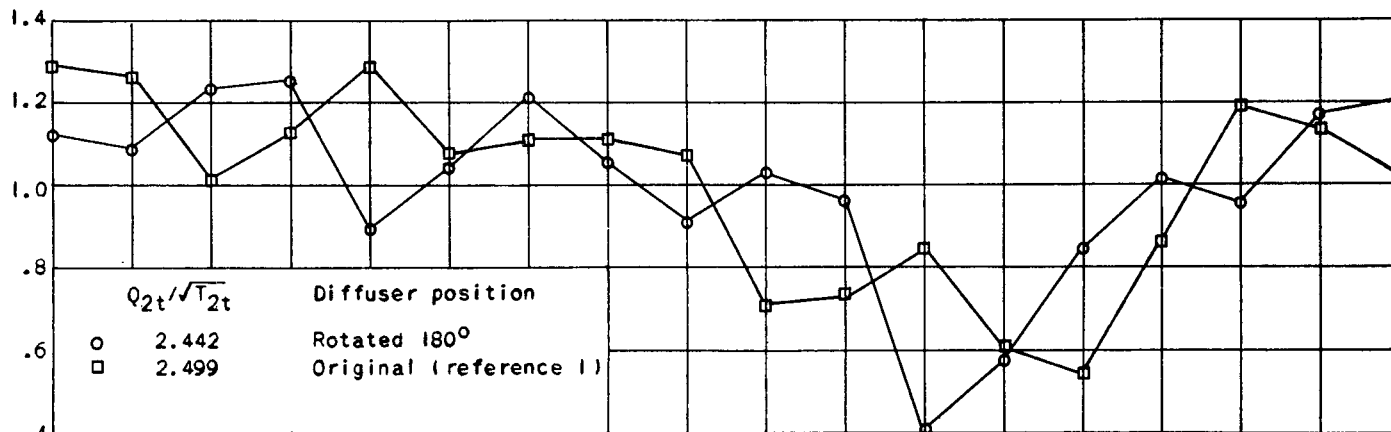

Figure 5. - Effect of rotating standard 13-vane diffuser 180° on air-flow distribution in supercharger outlets. Reference outlet pressure, 6 inches mercury gage; carburetor-throttle angle, 66°.



(c) $Q_{2t}/\sqrt{T_{2t}}$, approximately 2.5; engine speed, 2400 rpm.

NATIONAL ADVISORY
COMMITTEE FOR AERONAUTICS

M/M_a

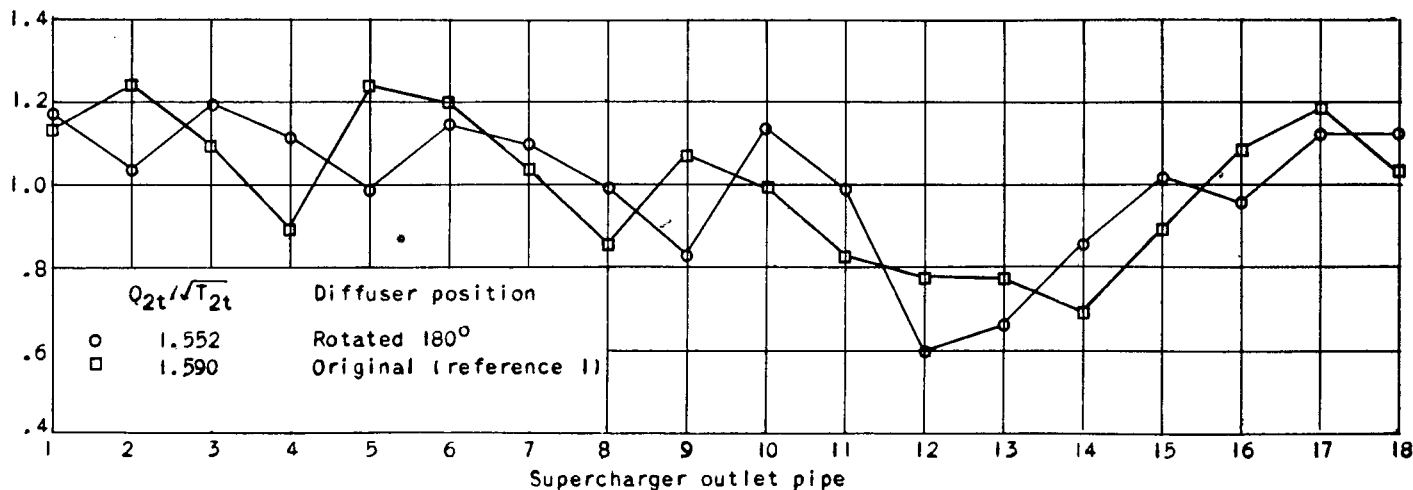

(d) $Q_{2t}/\sqrt{T_{2t}}$, approximately 1.6; engine speed, 2400 rpm.

Figure 5. - Concluded. Effect of rotating standard 13-vane diffuser 180° on air-flow distribution in supercharger outlets. Reference outlet pressure, 6 inches mercury gage; carburetor-throttle angle, 66°.

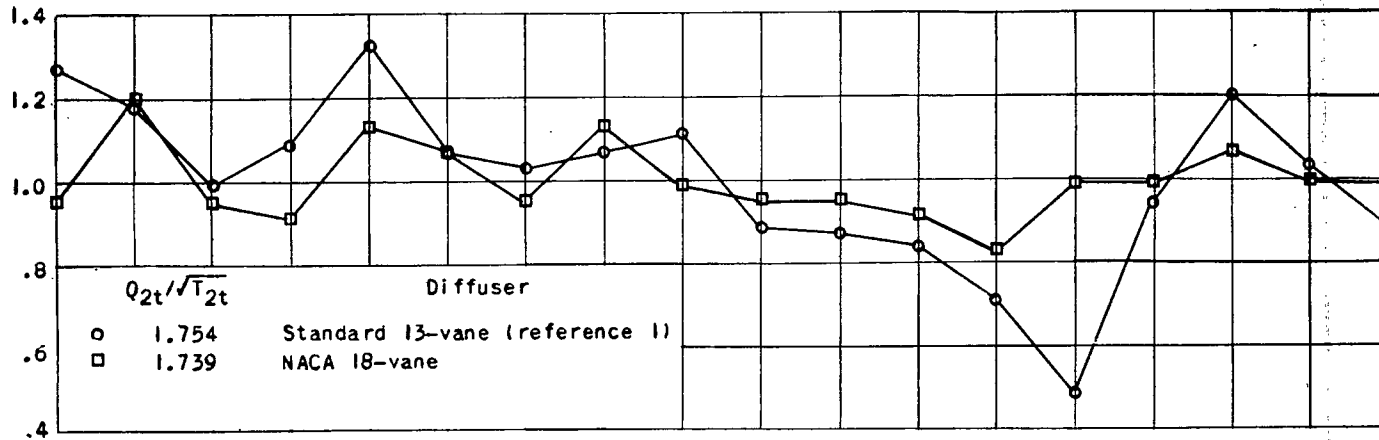

(a) $Q_{2t}/\sqrt{T_{2t}}$, approximately 1.7; engine speed, 2000 rpm.

NATIONAL ADVISORY
COMMITTEE FOR AERONAUTICS

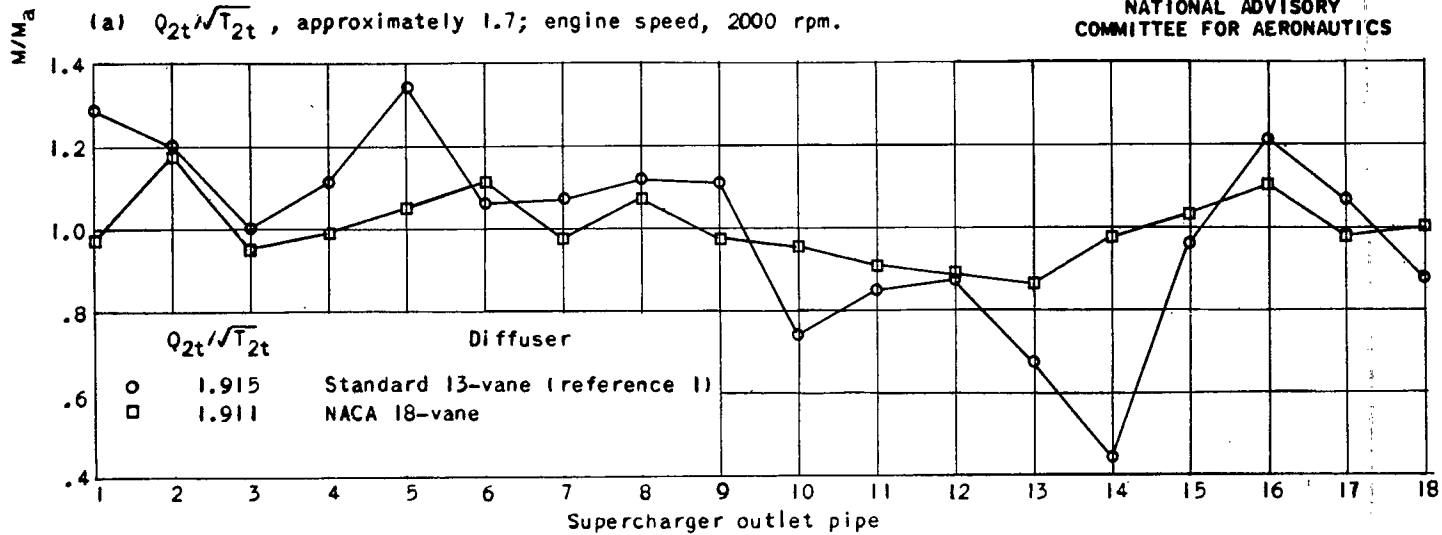

(b) $Q_{2t}/\sqrt{T_{2t}}$, approximately 1.9; engine speed, 2000 rpm.

Figure 6. - Comparison of air-flow distribution in supercharger outlets with standard 13-vane diffuser and NACA 18-vane diffuser. Reference outlet pressure, 6 inches mercury gage; carburetor-throttle angle, 66°.

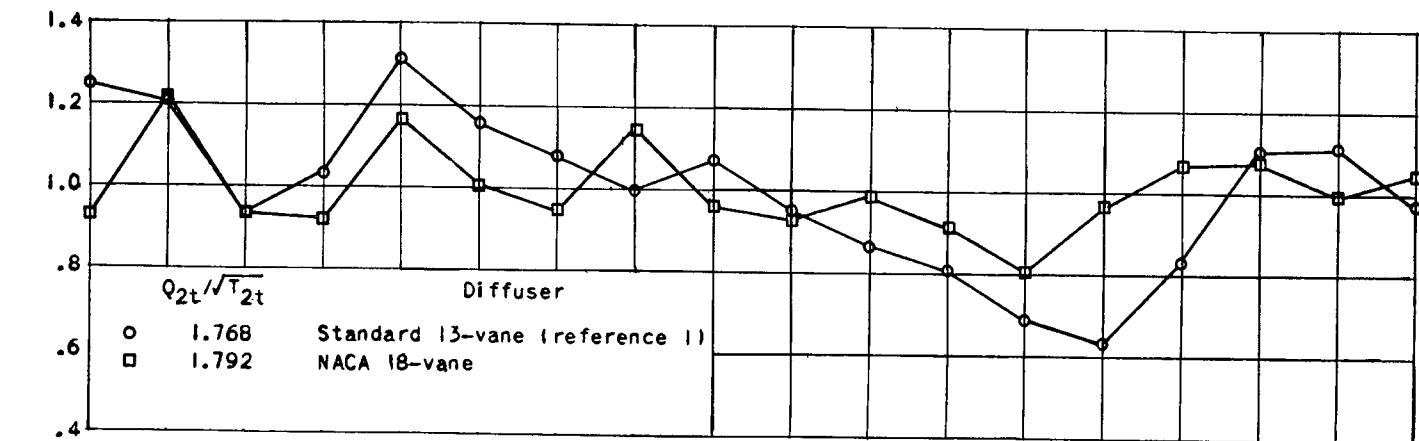

(c) $Q_{2t}/\sqrt{T_{2t}}$, approximately 1.8; engine speed, 2400 rpm.

NATIONAL ADVISORY
COMMITTEE FOR AERONAUTICS

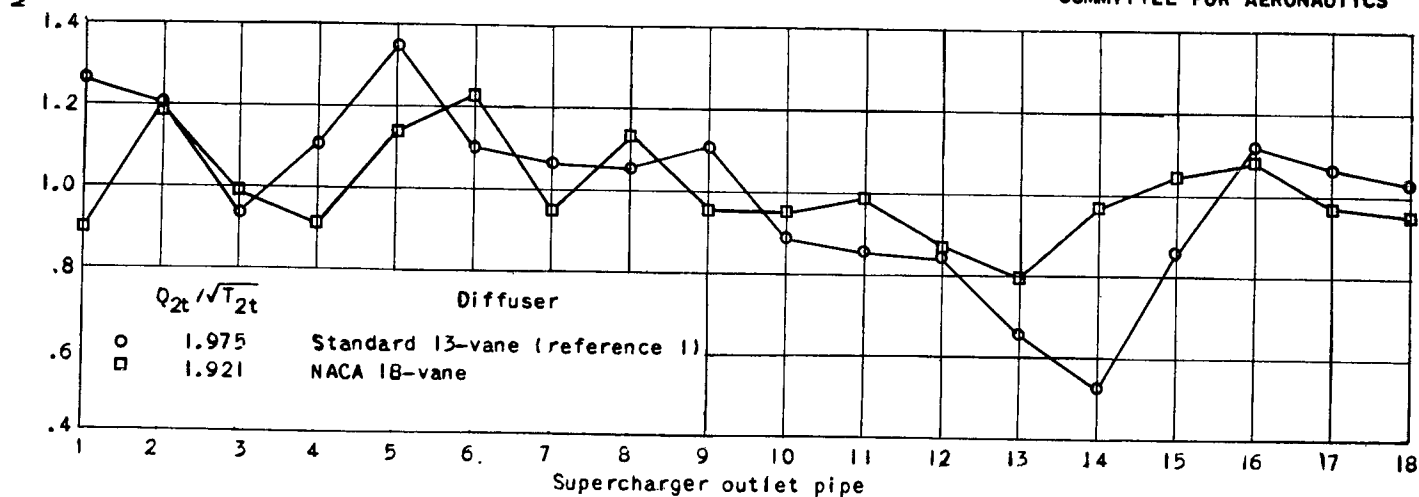

(d) $Q_{2t}/\sqrt{T_{2t}}$, approximately 1.95; engine speed, 2400 rpm.

Figure 6. - Concluded. Comparison of air-flow distribution in supercharger outlets with standard 13-vane diffuser and NACA 18-vane diffuser. Reference outlet pressure, 6 inches mercury gage; carburetor-throttle angle, 66° .

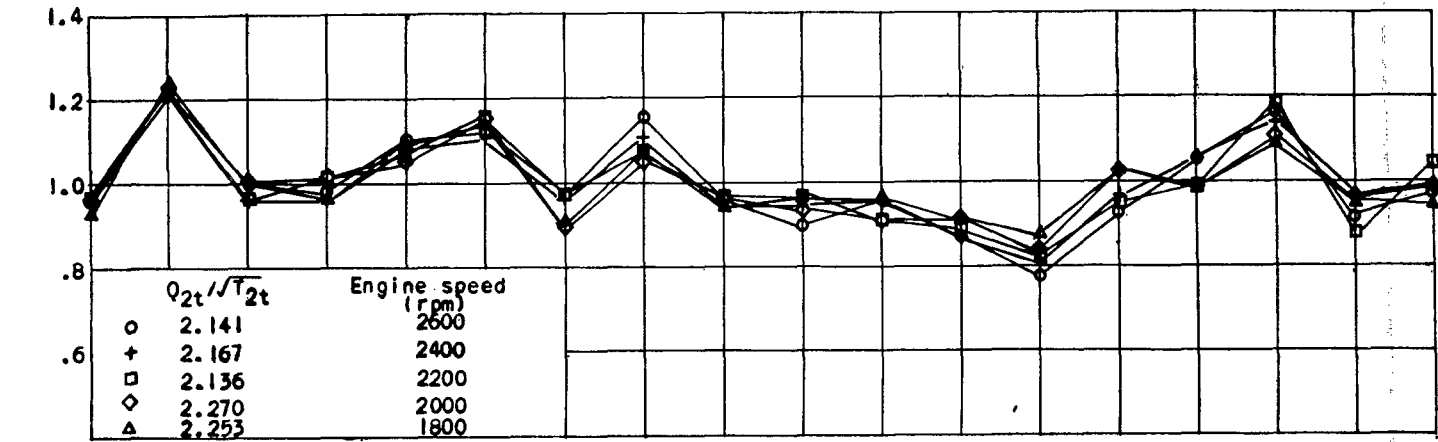

(a) $Q_{2t}/\sqrt{T_{2t}}$, approximately 2.2.

NATIONAL ADVISORY
COMMITTEE FOR AERONAUTICS

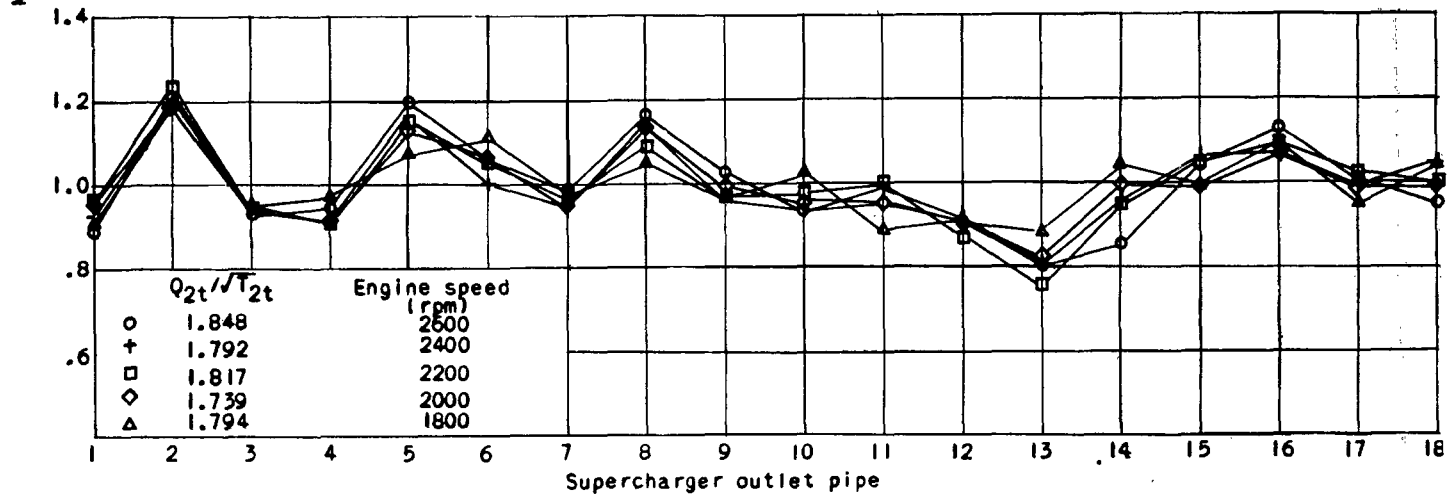

(b) $Q_{2t}/\sqrt{T_{2t}}$, approximately 1.8.

Figure 7. - Effect of engine speed on air-flow distribution in supercharger outlets with NACA 18-vane diffuser. Reference outlet pressure, 6 inches mercury gage; carburetor throttle angle, 66°.

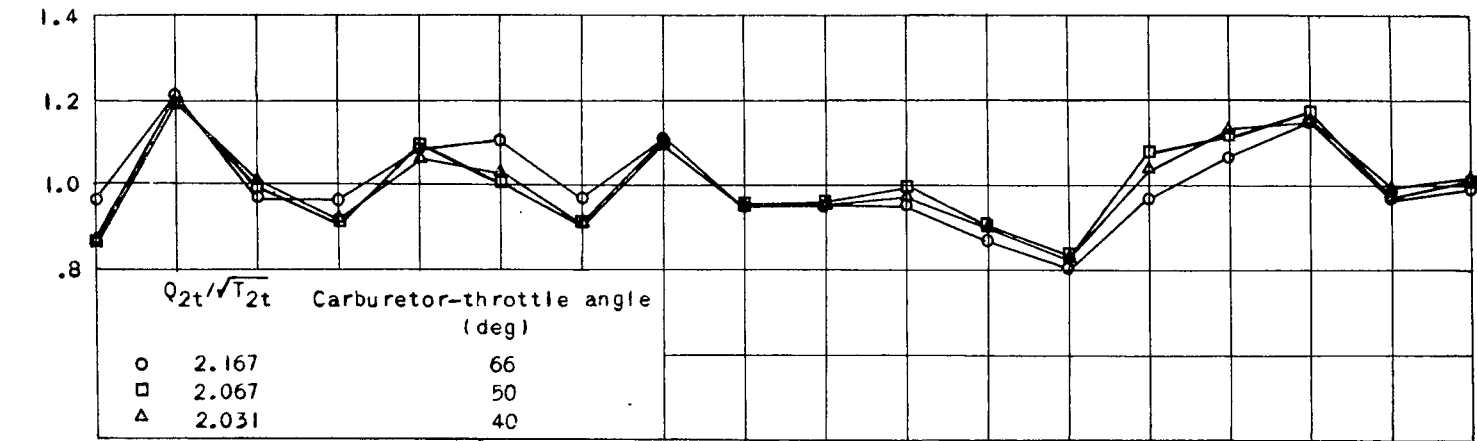

(a) $Q_{2t}/\sqrt{T_{2t}}$, approximately 2.1; engine speed, 2400 rpm.

NATIONAL ADVISORY
COMMITTEE FOR AERONAUTICS

M/M_a

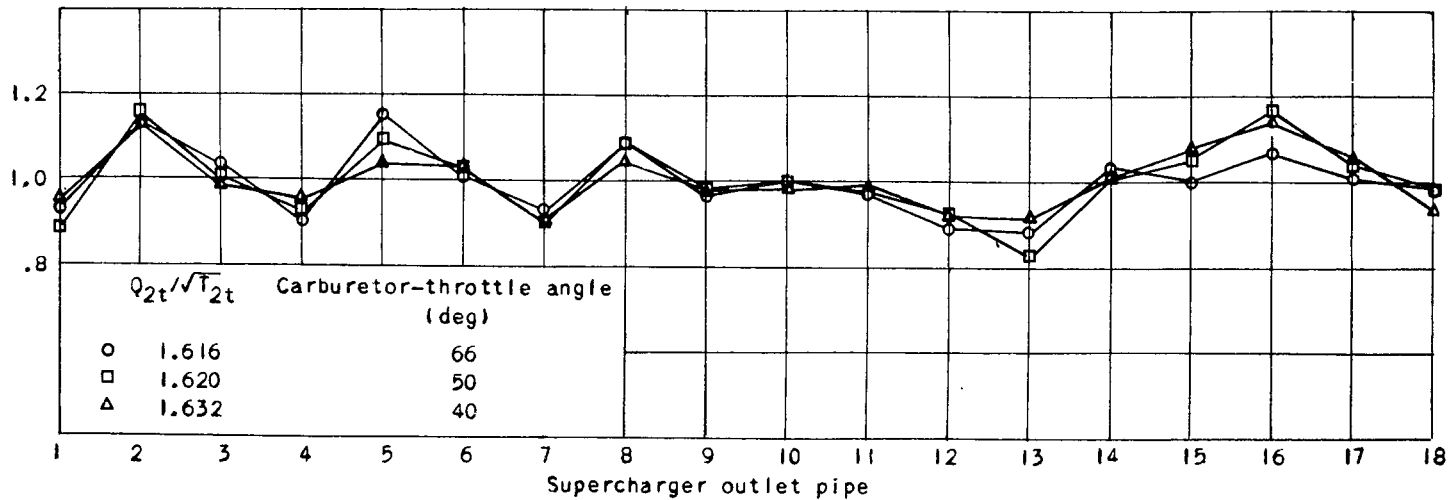

(b) $Q_{2t}/\sqrt{T_{2t}}$, approximately 1.6; engine speed, 2000 rpm.

Figure 8. - Effect of carburetor-throttle angle on air-flow distribution in supercharger outlets with NACA 18-vane diffuser. Reference outlet pressure, 6 inches mercury gage.

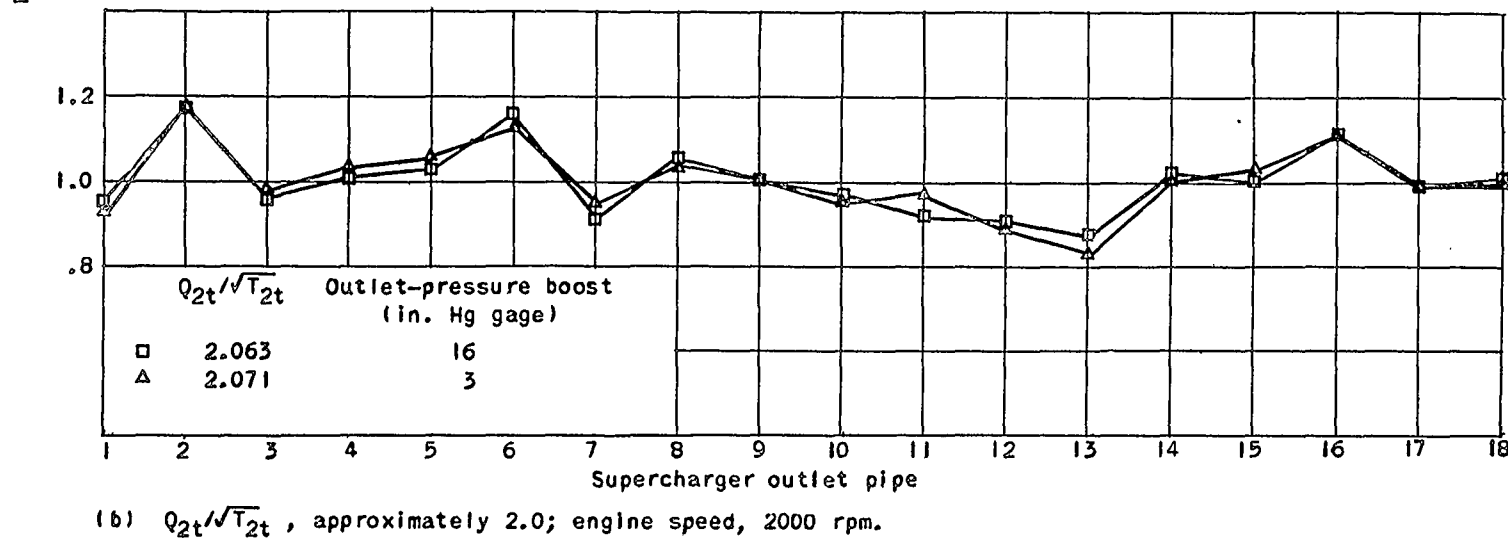
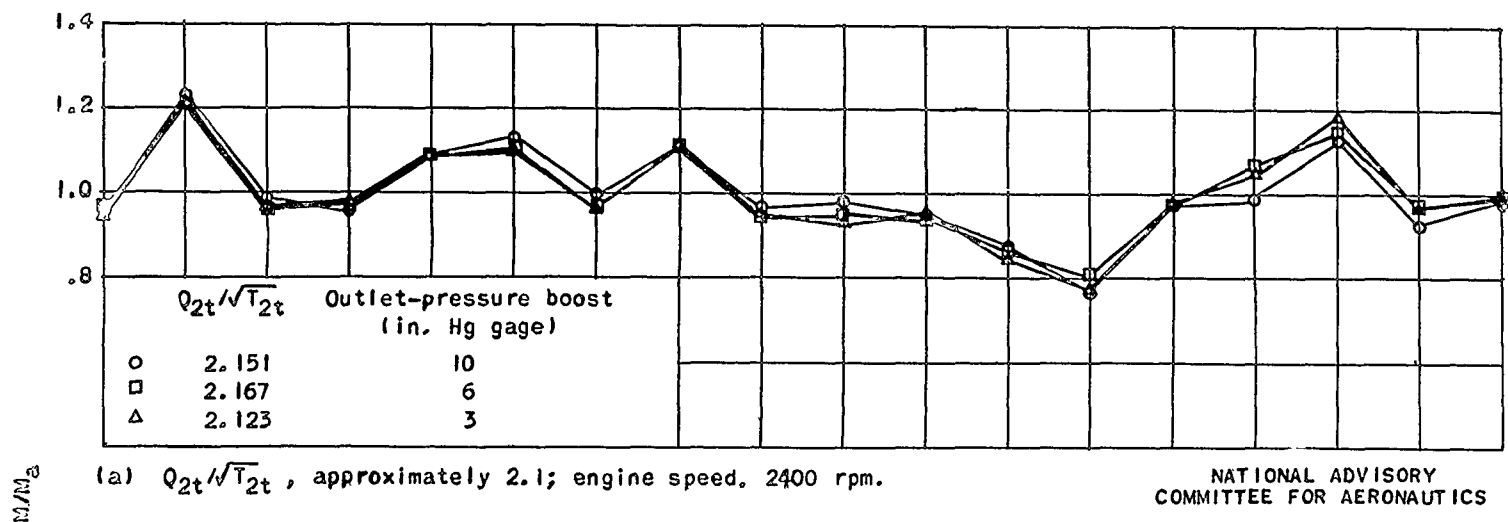
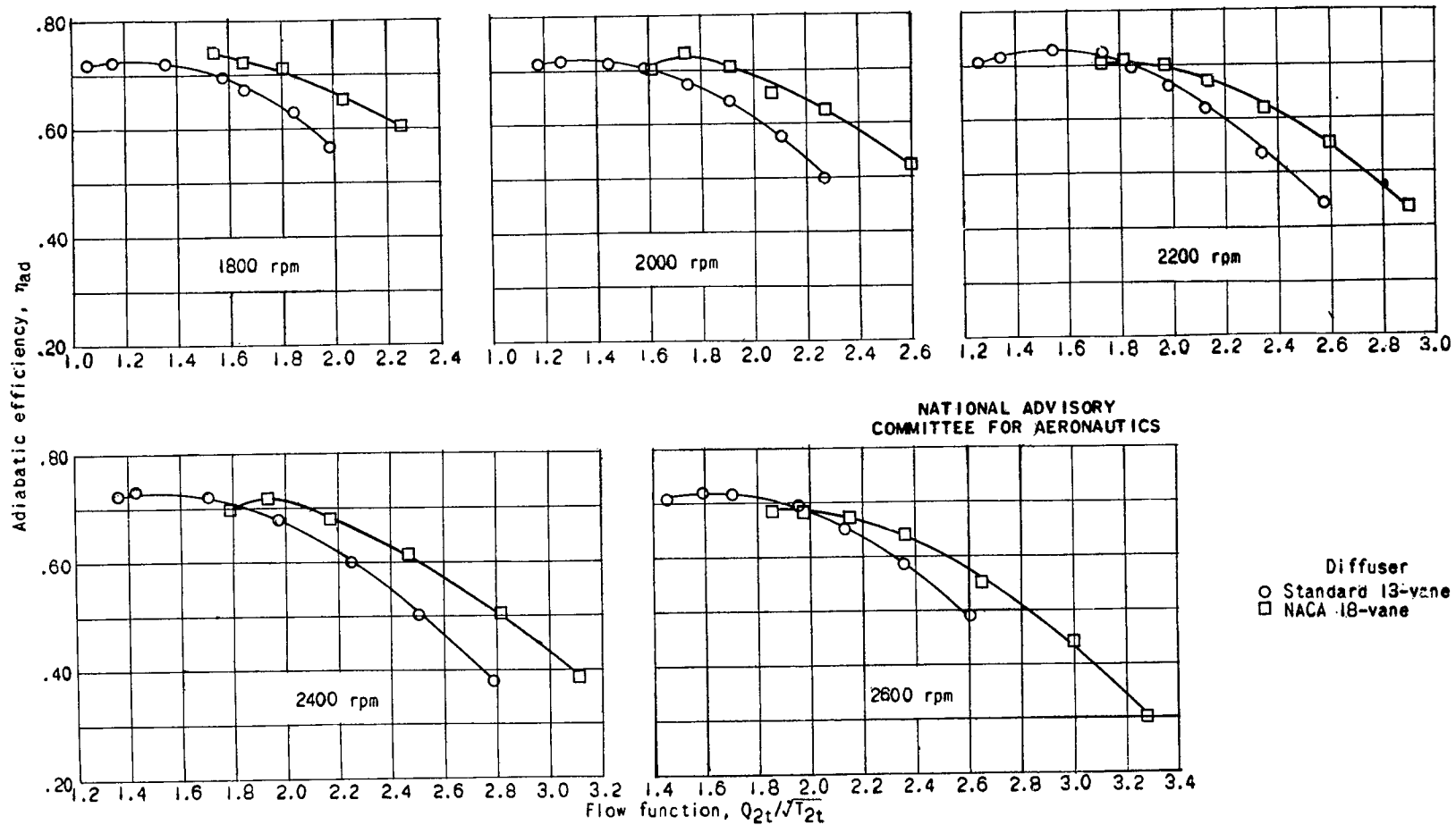

Figure 9. - Effect of outlet pressure on air-flow distribution in supercharger outlets with NACA 18-vane diffuser. Carburetor-throttle angle, 66°.



(a) Adiabatic efficiency.

Figure 10. - Comparative performance of engine-stage supercharger with standard 13-vane diffuser and with NACA 18-vane diffuser. Reference outlet pressure, 6 inches mercury gage; carburetor-throttle angle, 66°.

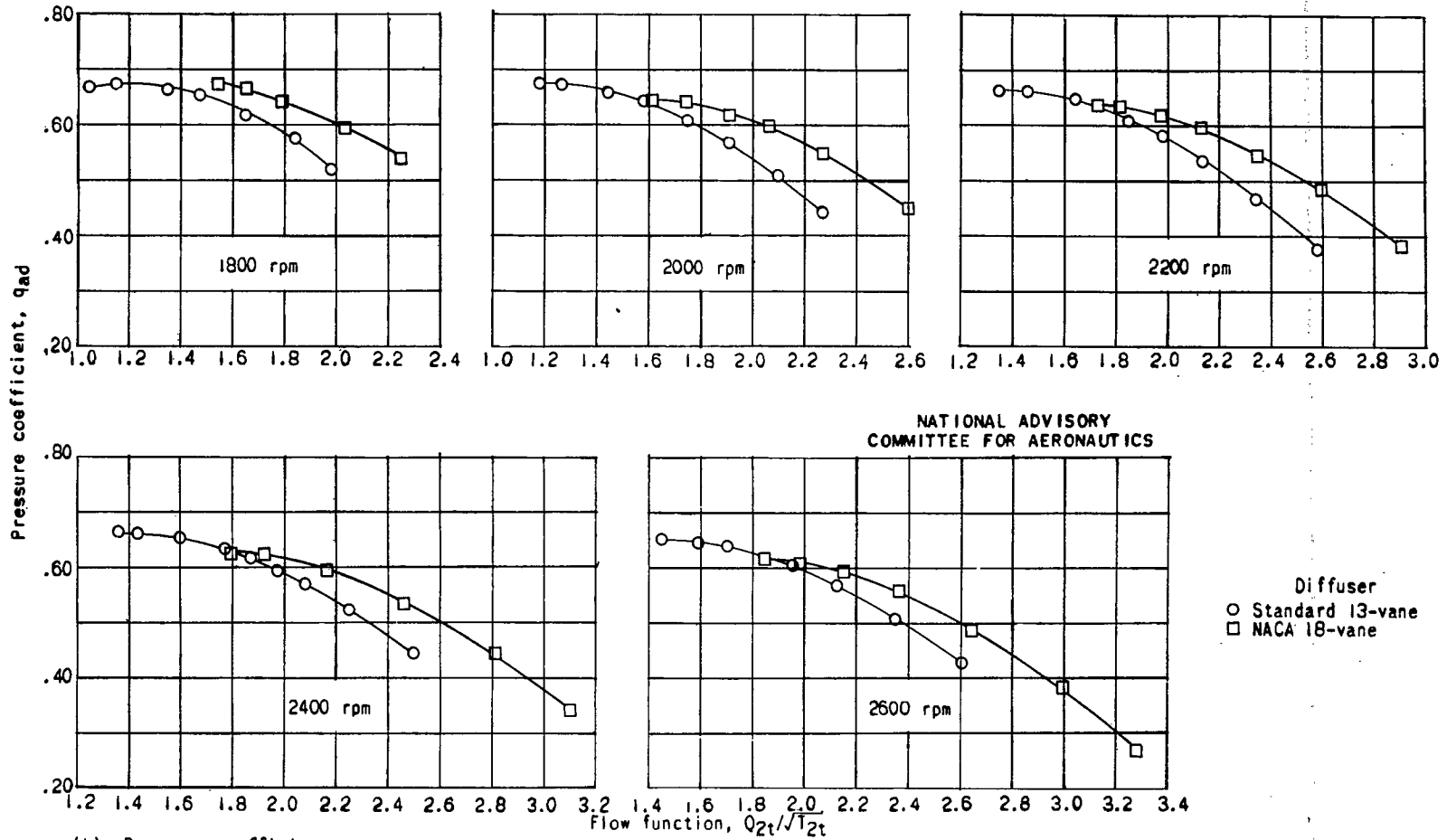

Figure 10. - Concluded. Comparative performance of engine-stage supercharger with standard 13-vane diffuser and with NACA 18-vane diffuser. Reference outlet pressure, 6 inches mercury gage; carburetor-throttle angle, 66°.

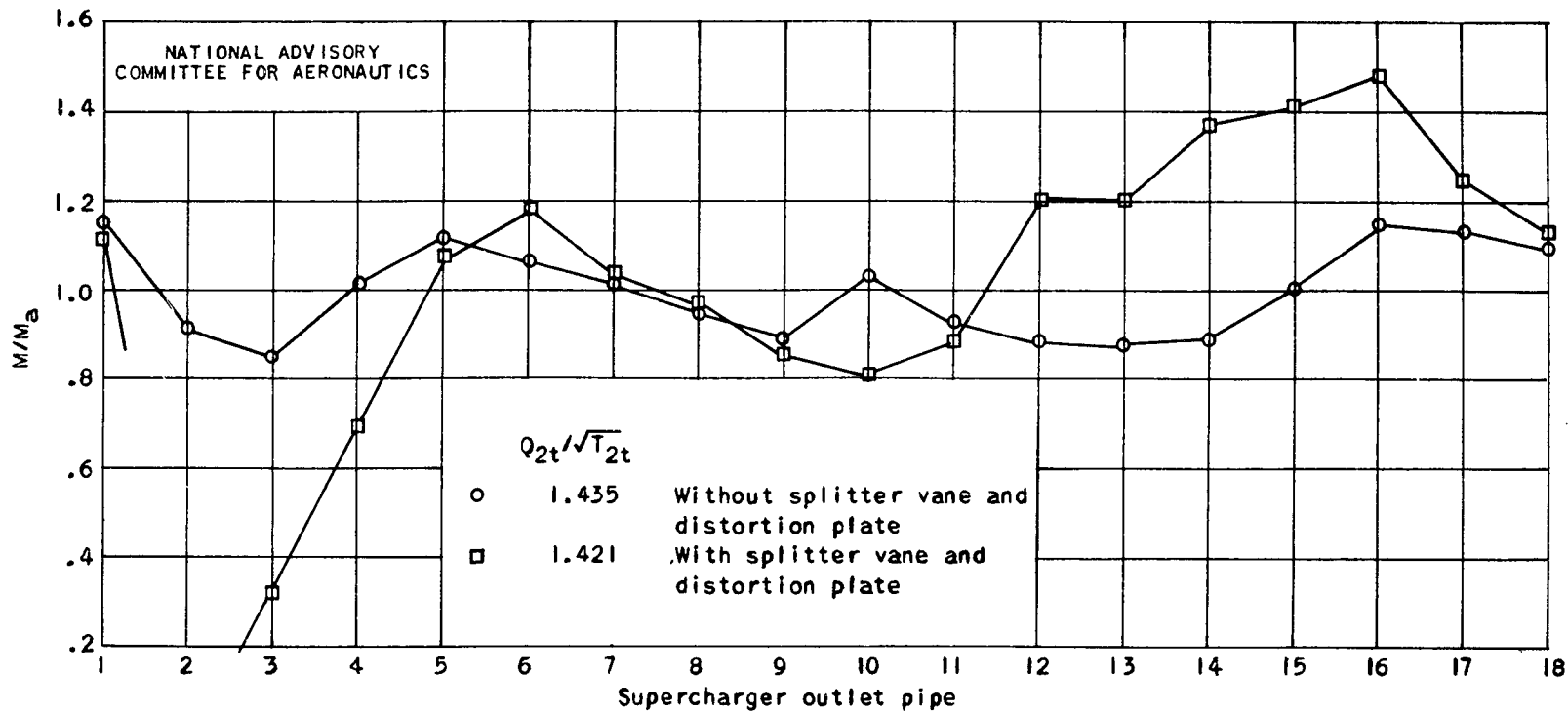

Figure 11. - Effect of distorting velocity profile at impeller inlet on air-flow distribution in supercharger outlets with vaneless diffuser. Reference outlet pressure, 6 inches mercury gage; carburetor-throttle angle, 66° ; engine speed, 2000 rpm.

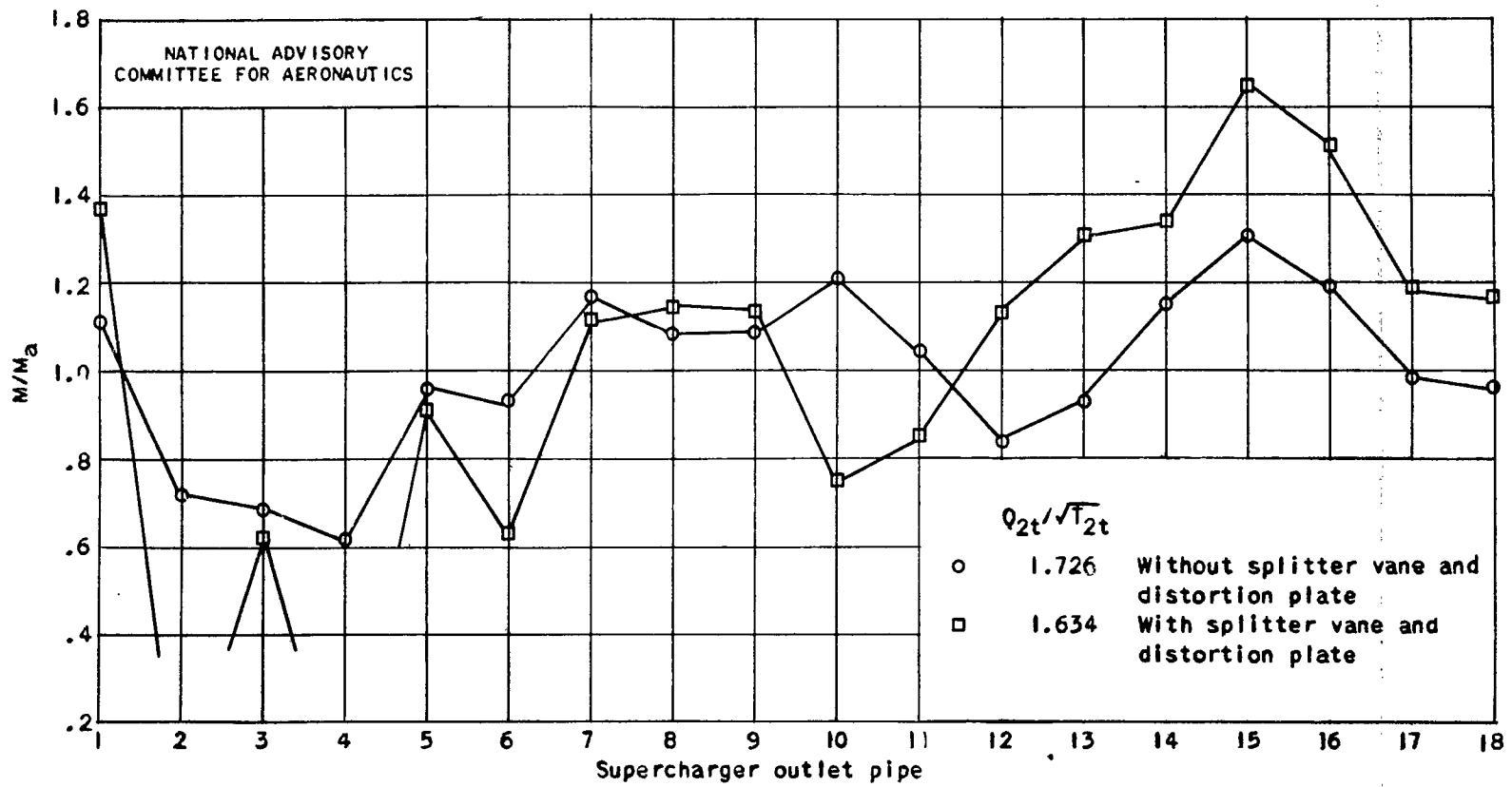

Figure 11. - Concluded. Effect of distorting velocity profile at impeller inlet on air-flow distribution in supercharger outlets with vaneless diffuser. Reference outlet pressure, 6 inches mercury gage; carburetor-throttle angle, 66°; engine speed, 2000 rpm.

LANGLEY RESEARCH CENTER



3 1176 01363 86