

1940

ARR No. 3E31

NATIONAL ADVISORY COMMITTEE FOR AERONAUTICS

WARTIME REPORT

ORIGINALLY ISSUED

May 1943 as
Advance Restricted Report 3E31

THE USE OF A RETRACTABLE PLANING FLAP

INSTEAD OF A FIXED STEP ON A SEAPLANE

By James M. Benson and Lindsay J. Lina

Langley Memorial Aeronautical Laboratory
Langley Field, Va.

NACA

WASHINGTON

NACA LIBRARY
LANGLEY MEMORIAL AERONAUTICAL
LABORATORY
Langley Field, Va.

NACA WARTIME REPORTS are reprints of papers originally issued to provide rapid distribution of advance research results to an authorized group requiring them for the war effort. They were previously held under a security status but are now unclassified. Some of these reports were not technically edited. All have been reproduced without change in order to expedite general distribution.

NATIONAL ADVISORY COMMITTEE FOR AERONAUTICS

ADVANCE RESTRICTED REPORT

THE USE OF A RETRACTABLE PLANING FLAP
INSTEAD OF A FIXED STEP ON A SEAPLANE

By James M. Benson and Lindsay J. Lina

SUMMARY

Data are presented and discussed to show the improvements in both the hydrodynamic and the aerodynamic performance of a seaplane that could be obtained if a retractable planing flap were used instead of the conventional main step. The improvements in resistance made possible by use of a planing flap to vary the depth of step during and after take-off are of the order of 8 percent in the water resistance at the hump speed and about 2 or 3 percent in the total air drag of a long-range flying boat of current design at cruising attitude. One type of retractable flap that could be used is described and the results of hydrodynamic stability tests of a model fitted with the flap are given. The tests indicated that very good stability characteristics could be provided with the planing flap for take-off and landing.

INTRODUCTION

In the design of the conventional flying boat, the depth of the main step is the result of a series of compromises. During the take-off, a shallow step is desirable for low water resistance up to and including hump speed; but a deeper step is essential at high speeds to avoid excessive water resistance and violent instability. While the seaplane - particularly a long-range seaplane - is in flight, the step may account for an important fraction of the parasite drag. Devices for retracting or removing the step in flight are frequently considered as a means of reducing the air drag, but the improvement to be obtained has apparently been insufficient to warrant the development and adoption of such devices. If a retractable device can be made to improve the take-off

performance as well as to decrease the air drag, its value may then become sufficient to warrant installation in the seaplane.

This report includes a limited collection of data to indicate the amount of improvement in air drag and in water resistance that may be obtained by the use of a retractable planing flap instead of a fixed step. A flap of the type required is described and the results of tests in NACA tank no. 1 of a dynamic model of a flying boat that had been fitted with several arrangements of the flap are presented to show the effects upon stability during take-off and landing.

EFFECT OF DEPTH OF STEP

Water resistance.— Tank tests have shown that at speeds below and at hump speed a small depth of step is desirable for low water resistance. For example, the data in reference 1 show that the resistance at best trim will be about 8 percent lower for a step having a depth of 1 percent of the beam than for one having a depth of 6 percent of the beam. A relatively deep step is required at speeds between hump speed and get-away speed because an insufficient depth of step may result in excessive wetting of the afterbody and rapid increase in water resistance just prior to the get-away, which can entirely prevent take-off. (See references 2 and 3.) In order to avoid this excessive wetting, a depth of step of not less than 5 percent of the beam is generally considered necessary; and in some heavily loaded flying boats a depth of step of as much as 7 percent of the beam is used.

Hydrodynamic stability.— The data in reference 4 indicate that a decrease in depth of the conventional step reduces the lower trim limit at and near hump speed, where low-angle porpoising is most likely to occur, but that at high speeds, where the high-angle type of porpoising presents a problem, either a relatively deep step or ventilation of a step of lesser depth is essential.

Air drag.— The effect of the depth of step on the air drag of a full-size seaplane float has been determined by tests in the NACA propeller-research tunnel, but the results have not yet been published. The float was of a

type currently used for an airplane with a normal gross load of 5300 pounds. The form of the original float, with the successive changes, is shown in figure 1. The step was reduced from the original depth to one-half the original depth and to zero by successively filling out the afterbody. The magnitudes of the air drags at zero pitch - which are practically the same as the minimum air drags - have been tabulated in figure 1, and the effect of reducing the depth of step is apparent.

The profile of the float with zero depth of step is about the same as the profile that would result from the use of a planing flap of the type shown in figure 2. The only important difference is that with the planing flap the angular break in the buttock lines would be somewhat farther forward. The results presented in figure 1 show that the minimum drag of the float could be reduced about 16 percent by use of the retractable planing flap. The percent reduction of the drag of a complete seaplane is of course a great deal less than for hull or float alone. Unpublished results of tests of a model of a flying boat made in the NACA full-scale tunnel bring this fact out clearly. The model used in the full-scale tunnel had a span of 35 feet and originally had a conventional step with a depth equal to 5 percent of the beam. It was complete with nacelles, tip floats, antenna mast, and loop. Tests of the original model at an airspeed of 100 miles per hour indicated that the flying boat would have a maximum lift-drag ratio of 17.4. When a fairing was added aft of the step, the lift-drag ratio was increased to 17.7. The ranges corresponding to the two conditions were computed from Bréguet's range formula and the model with the faired step showed an increase of 2 percent in the range.

Additional data on the effect of the depth of step on the air drag of hulls and floats are given in reference 5.

DESCRIPTION OF PLANING FLAP

Numerous arrangements have been suggested whereby the air drag of a hull may be reduced by fairing the step in flight. Figure 3 shows one of the simplest arrangements, which was represented by the fairing used in the full-scale tunnel tests referred to previously. The

transition flap shown is a surface hinged at about 1 beam length abaft the step and is deflected in flight to reduce the depth of the step to zero. One advantage of this type of flap is that the loads imposed by the water reactions occur when the flap is seated against the main structure of the hull. In the extended position the only loads on the flap are the smaller loads imposed by the air flow.

Figures 2 and 4 illustrate a type of flap that offers interesting possibilities in performing functions other than the reduction of the air drag. This flap may be used to reduce the water resistance at and near hump speed and to improve the stability characteristics during take-off and landing. A transverse axis is selected at or slightly above the chines and at a suitable distance forward of the step. The flap is a movable section of the hull, having a V-bottom with chine flare, if desired, and is bounded on the after end by a cylindrical surface having as its center line the hinge axis of the flap. On the forward end the flap is bounded by a surface formed by rotating a transverse section of the V-bottom about the hinge axis. The extent of the curved surfaces at the ends depends upon the angular deflection required and upon the structural details. The thickness of the flap would be somewhat greater than the vertical distance from keel to chine. The resulting boxlike structure would be of about the same type as would probably be required in any form of planing flap designed to withstand the pressures developed on the forebody in the vicinity of the step. The flap may easily be adapted to provide ventilation by means of ducts from the sides above the chine of the flap to the after end in order to discharge air through the riser of the main step.

Although the present discussion is confined to consideration of the main step, the type of flap described in the foregoing paragraphs may be used at other places on the planing bottom. This type of flap offers a relatively simple solution to the problem of incorporating chine flare in the flap and of deflecting the flap without opening a gap at the keel. The plan form of the step shown in figure 4 departs slightly from the straight transverse form (with a vertical step) that is often used. The departure may, however, be made so small that the hydrodynamic properties will not be affected appreciably. For special applications the trailing edge of the flap

may have any of a wide variety of shapes and may present a step resembling closely almost any form of V-step or pointed step.

DESCRIPTION OF MODEL

A dynamic model of a flying boat was tested in NACA tank no. 1 to investigate the effect on the dynamic stability of fitting flaps of the type shown in figure 2. The model is similar to and about one-half as large as the model used in the tests in the full-scale tunnel, which was previously described. The hull of this model is outlined in figure 2. The construction of the model followed the usual practice at NACA tank no. 1 as described in reference 4.

Dimensions and weights of the basic model, which is designated NACA model 134, are as follows:

Maximum beam (1.00 beam), inches	14.24
Beam at step (0.97 beam), inches	13.86
Forebody length (bcw to step), inches	51.70
Over-all length, inches	124.05
Angle of dead rise, excluding chine flare, degrees	20
Wing area, square feet	25.6
Wing span, inches	200
Length of M.A.C. (wing), inches	20.12
Angle of incidence of wing, M.A.C. to forebody keel, degrees	3.2
Horizontal tail area, square feet	3.51
Pitching moment of inertia, slug-feet ²	6.9
Center of gravity forward of step, inches	From 5.56 to 6.00
Center of gravity above forebody keel at step, inches	12.23
Gross load coefficient, light	0.87
Gross load coefficient, heavy	0.98

The moment of inertia is a scale value typical of current practice in the design of large flying boats. The distance of the center of gravity forward of the step was adjusted during the tests as required to obtain the trim limits. The gross load coefficient is expressed as

$$C_{\Delta_0} = \Delta_0 / wb^3$$

where

Δ_0 initial load on water, pounds

b maximum beam of model, feet

w specific weight of water, pounds per cubic foot
(63.2 lb/cu ft for the water in NACA tank no. 1)

Modifications to the model were made as shown in figure 5. In each case the step was straight transversely and vertically. Deviations that would be required by use of the flap were considered insufficient in importance to justify incorporating them in the model for the present tests.

TEST PROCEDURE

The test procedure was in general the same as that usually employed at the NACA tanks and is described in reference 4.

Trim limits.— The model was towed free to trim and rise and the elevators were manipulated to determine the range of trim for which the model was stable. Successive runs were made at constant speeds ranging from the lowest at which porpoising could be obtained up to take-off speeds. In this way the lower trim limit (below which the model would porpoise) and the upper branch of the upper trim limit (above which porpoising always occurred) were determined in the manner described in reference 4. The lower branch of the upper limit was determined by trimming the model above the upper branch and, after porpoising became well established, the trim of the model was gradually lowered until it recovered and ran stably. The trim at which recovery took place determined a point on the lower branch of the upper limit. In the determination of the trim limits, any regular and recurrent oscillation in trim and rise of sufficient amplitude to be observed unmistakably was considered porpoising.

Stable range of position of center of gravity.— With one of the better arrangements of the flap, the model was towed with the elevator fixed in the neutral position and again in the full-up position during accelerated runs. The speed was increased steadily from rest to a speed above get-away and observations were made of the trim when

the model ran stably and of the maximum and minimum trims when porpoising occurred. The runs were repeated for several positions of the center of gravity to determine the fore-and-aft range for which porpoising would not occur with either full-up or neutral elevator.

Landing stability.— Observations of the behavior of the model on landing were made by flying the model off the water, decelerating the towing carriage while the elevator of the model was adjusted to obtain the desired trim at contact, and then noting any tendency of the model to skip or porpoise after landing. The rate of deceleration was approximately the same in each case.

RESULTS AND DISCUSSION OF STABILITY TESTS

Trim limits of stability.— The plots of trim limits of stability, presented in figures 3 to 9 and summarized in figure 10, show that all arrangements of the planing flap caused a marked lowering of the lower limit, which amounted to about 4° for the 2.2° flap, about 3° for the 4.5° flap, and between 5° and 7° for the short flap.

All flaps caused the upper branch of the upper limit to be lowered by amounts ranging from 1° to about 2.5° . The short flap caused the lower branch of the upper limit to be lowered sharply, the effect being as much as 7° . The long flaps lowered the lower branch by smaller amounts—about 3° for the flap deflected 4.5° , and about 2° for the flap deflected 2.2° .

Limiting positions of center of gravity.— Figure 11 shows the variation of trim with speed for neutral and for full-up elevator with the center of gravity at three different locations. No porpoising occurred with the center of gravity at 36-percent or at 40-percent mean aerodynamic chord. With the center of gravity at 32-percent mean aerodynamic chord, no porpoising occurred with full-up elevator. With neutral elevator and with the center of gravity at 34-percent mean aerodynamic chord, however, the trim of the model passed below the lower limit at about 20 feet per second and the low-angle type of porpoising followed. Comparison of figure 11 with figure 10 shows that with full-up elevator and with the center of gravity at 40-percent mean aerodynamic chord,

the trim of the model at a speed of about 40 feet per second was near the upper branch of the upper limit and that porpoising might occur if the model were accelerated at a much lower rate through this unstable region near get-away. The plots indicate that the stable range of positions for the center of gravity is from about 33 to 40 percent of the mean aerodynamic chord if the stable range is defined as that range for which porpoising will not occur with either neutral or full-up elevator. Obviously, the stable range will be influenced to an important extent by the effects that thrust, slipstream, and variations in the deflection of the aerodynamic flaps will have on the trim and on the wing lift. The range of 7 percent, although smaller as compared with that which is commonly provided for in flight, is typical of the value obtained in tests of conventional dynamic models without powered propellers.

The foregoing interpretation of the data obtained during the accelerated runs is based on the criterions for stability as proposed by Stout (reference 6) to assure that a seaplane will be hydrodynamically stable for all positions of the center of gravity likely to occur in practice. The concept of a stable range of the position of the center of gravity is essential and must be dealt with in practice, but there may be doubt as to the trimming-moment criterions that should be used. The criterion that both full-up and neutral elevator must be available without causing excessive porpoising may in some cases be unnecessarily conservative. If it is assumed that the pilot will take precautions to avoid porpoising, the model with the planing flap will probably have a satisfactory range of stable positions of the center of gravity. In a specific design the location of the step relative to the wing may differ from that used in the present tests in order that the hydrodynamically stable range be within the range for which the seaplane was designed to fly.

Skipping.— Observations on the behavior of the model after landing are listed in tables I and II. The short flap deflected 7° caused very severe skipping after landing and for that reason alone probably would be impracticable. The trim limits for the short flap show that a high probability of skipping or some form of instability should be expected when a landing is made at trims greater than about 4° because of the unfavorable lower branch of

the upper limit. The sinking speed of most landings would be sufficient to provide an impulse that would be likely to cause the high-angle type of porpoising to appear at trims considerably below the upper branch of the upper limit.

When the model with the long flap was landed at some of the higher trims, skipping occurred. In general, the model with the long flap appeared to have a slightly greater skipping tendency than did the basic model with an equal depth of step. The type of motions involved, however, were much less violent with the long flap than with the short flap.

The phenomenon of skipping may be considered as involving one or more of at least three different types of instability. The first, and most important type, is that involving "sticking" and is commonly associated with insufficient depth of step. If the supply of inflowing air aft of the step is inadequate, rather large negative pressures occur intermittently on the afterbody near the step and cause rapid fluctuations in the draft of the seaplane. The motions that follow are usually violent and the seaplane may leap clear of the water at speeds and attitudes unsafe either for flight or for landing. This type of instability may be prevented by furnishing an ample supply of air either by an increase in the depth of step or by the use of relatively large ventilation orifices at the step near the keel.

A second type of instability is merely a recoil that occurs with no change in trim and has been observed during tank tests of single planing surfaces being towed free to rise at fixed trim. Planing surfaces have bounced clear of the water several times after being dropped into the water with a light load at high forward speeds.

A third type of instability is the result of a difference between the equilibrium attitude while the seaplane is in flight and the attitude it assumes after it alights on the water. With the center of gravity well forward, contact with the water may cause an immediate decrease in trim, which reduces both the lift coefficient of the wing and the planing coefficient of the bottom. A reduction in either coefficient will cause the model to sink deeper into the water. If equilibrium is approached asymptotically, no bouncing occurs. With the center of

gravity well aft, an increase in trim will probably follow the landing and both the wing and planing bottom will give an upward impulse that will be followed by a downward motion as the forward speed decreases. Thus, forward positions of the center of gravity add damping to any skipping tendency; whereas aft positions tend to accentuate this type of instability. This effect of the position of the center of gravity is shown by comparing the data in table II for the center of gravity at 28-percent mean aerodynamic chord with the results for the center of gravity at 40-percent mean aerodynamic chord.

Skipping or bouncing caused by any one or more of the three types of instability is undesirable, but the type most likely to be unsafe and divergent is that which involves sticking of the afterbody.

The results of the stability tests indicate that the violent types of instability may be avoided if both sufficient depth of step is provided and the planing bottom of the forebody is straight longitudinally for a distance forward of the step equal to about 1 beam length. Both conditions appear to be satisfied if a retractable flap having a length equal to the beam is used with a deflection of about 2.2° or possibly as much as 4° .

CONCLUDING REMARKS

A retractable planing flap may be used instead of a fixed step to vary the depth of step during and after take-off in order to lower the resistance both on the water and in the air. Such a flap may also be used to improve the hydrodynamic stability characteristics. For a long-range flying boat of current design, the possible reduction in water resistance at hump speed will be about 8 percent. The reduction in air drag of the complete flying boat at cruising attitude will be of the order of 2 percent. The planing flap may be used to improve stability characteristics by making possible the use of a shallow step at hump speed and a deep step at high speeds. The shallow step would increase the effectiveness of the afterbody at low speeds and would thereby increase the speed at which low-angle porpoising could first occur during take-off. The deep step at high speeds would as-

sure ample clearance of the afterbody and would thereby remove to a large extent the probability of sticking and the associated type of high-angle instability.

Langley Memorial Aeronautical Laboratory,
National Advisory Committee for Aeronautics,
Langley Field, Va.

REFERENCES

1. Bell, Joe W.: The Effect of Depth of Step on the Water Performance of a Flying-Boat Hull Model - N.A.C.A. Model 11-C. T.N. No. 535, NACA, 1935.
2. Truscott, Starr, Parkinson, J. B., Ebert, John W., Jr., and Valentino, E. Floyd: Hydrodynamic and Aerodynamic Tests of Models of Flying-Boat Hulls Designed for Low Aerodynamic Drag. T.N. No. 668, NACA, 1938.
3. Diehl, Walter S.: A Discussion of Certain Problems Connected with the Design of Hulls of Flying Boats and the Use of General Test Data. Rep. No. 625, NACA, 1938.
4. Olson, Roland E., and Land, Norman S.: The Longitudinal Stability of Flying Boats as Determined by Tests of Models in the NACA Tank. I - Methods Used for the Investigation of Longitudinal-Stability Characteristics. NACA A.R.R., Nov. 1942.
5. Hartman, Edwin P.: The Aerodynamic Drag of Flying-Boat Hull Models as Measured in the NACA 20-Foot Wind Tunnel - I. T.N. No. 525, 1935.
6. Stout, Ernest G.: Experimental Determination of Hydrodynamic Stability. Jour. Aero. Sci., vol. 8, no. 2, Dec. 1940, pp. 55-61.

TABLE I.- EFFECT OF VARYING THE CHORD OF A PLANING FLAP
ON THE LANDING STABILITY

Model 134PF			Model 134PF-2			Model 134PF-2		
Chord, 1.0 beam c.g., 34-percent M.A.C. Step depth, 0.14 beam			Chord, 0.4 beam c.g., 34-percent M.A.C. Step depth, 0.10 beam			Chord, 0.4 beam c.g., 40-percent M.A.C. Step depth, 0.10 beam		
C_{Δ_0} , 0.67..								
Trim (deg)	Landing speed (fps)	Remarks	Trim (deg)	Landing speed (fps)	Remarks	Trim (deg)	Landing speed (fps)	Remarks
---	---	-----	13.0	42.4	2 skips	---	---	-----
11.5	43.6	2 skips	---	---	-----	---	---	-----
9.5	43.8	2 skips	---	---	-----	10.0	39.8	3 skips
---	---	-----	8.0	46.4	3 skips	---	---	-----
7.2	45.6	2 skips	7.0	46.4	Several skips	7.5	39.7	4 skips
5.0	46.1	1 skip	5.5	47.0	4 skips	5.5	45.0	7 skips
---	---	-----	3.0	50.4	Stable	3.5	45.2	5 skips
---	---	-----	---	---	-----	2.0	44.4	Stable

12-1

COMPARISON OF THE LANDING STABILITY OF A MODEL WITHOUT A PLANING FLAP
AND WITH A PLANING FLAP AT TWO DEFLECTIONS

[Chord of planing flap, 1 beam]

Model 134PF $\delta_{pf} = 4.5^\circ$ Step depth, 0.14 beam (1)			Model 134PF-3 $\delta_{pf} = 2.2^\circ$ Step depth, 0.14 beam (1)			Model 134C No planing flap		
Trim (deg)	Landing speed (fps)	Remarks	Trim (deg)	Landing speed (fps)	Remarks	Trim (deg)	Landing speed (fps)	Remarks
C_{A_0} , 0.87; c.g., 28-percent M.A.C.								
12.0	42.0	1 skip	12.0	43.0	2 skips	11.0	42.9	1 skip
10.0	43.0	2 skips	10.0	43.5	2 skips	12.0	41.6	Stable
6.0	44.0	2 skips	7.5	42.0	3 skips	11.0	41.4	Stable
3.0	45.0	1 skip	6.0	44.5	1 skip	10.0	41.9	1 skip
---	---	---	4.0	46.0	1 skip	9.0	42.1	1 skip
---	---	---	1.0	49.0	Stable	7.5	41.4	1 skip
---	---	---	---	---	---	6.0	44.6	Stable
---	---	---	---	---	---	3.5	47.5	Stable
---	---	---	---	---	---	---	---	---
C_{A_0} , 0.98; c.g., 28-percent M.A.C.								
12.0	45.5	1 skip	11.0	45.5	2 skips	11.0	43.3	1 skip
10.0	45.0	1 skip	11.5	45.5	1 skip	11.5	44.9	Stable
9.5	44.0	Stable	10.0	45.0	2 skips	10.0	45.7	1 skip
7.0	46.5	Stable	8.0	45.0	3 skips	---	---	---
6.0	No reading	Stable	---	---	---	7.5	45.8	1 skip
4.0	50.5	Stable	6.0	45.0	1 skip	6.0	46.6	1 skip
---	---	---	4.0	48.0	1 skip	4.0	48.5	1 skip
---	---	---	1.0	52.5	1 skip	---	---	---
---	---	---	---	---	---	---	---	---
C_{A_0} , 0.87; c.g., 40-percent M.A.C.								
---	---	---	12.0	41.6	5 skips	12.0	42.0	2 skips
---	---	---	10.0	41.0	4 skips	10.0	42.5	2 skips
---	---	---	7.5	41.8	5 skips	8.0	44.0	1 skip
---	---	---	5.5	42.4	1 skip	6.0	44.0	2 skips
---	---	---	4.0	43.6	1 skip	3.5	46.0	Stable
---	---	---	1.5	48.4	1 skip	---	---	---
---	---	---	---	---	---	---	---	---
C_{A_0} , 0.98; c.g., 40-percent M.A.C.								
12.0	42.5	9 skips	12.5	44.6	7 skips	12.0	45.0	3 skips
10.0	44.0	9 skips	9.5	44.4	4 skips	10.0	44.0	2 skips
3.0	44.0	7 skips	7.5	45.2	5 skips	8.0	44.5	2 skips
6.0	45.5	3 skips	5.0	45.4	1 skip	6.0	46.0	1 skip
4.0	47.5	2 skips	---	---	---	4.0	50.0	1 skip
2.0	48.5	2 skips	---	---	---	---	---	---
---	---	---	1.0	55.0	Stable	---	---	---

¹ δ_{pf} deflection of planing flap.

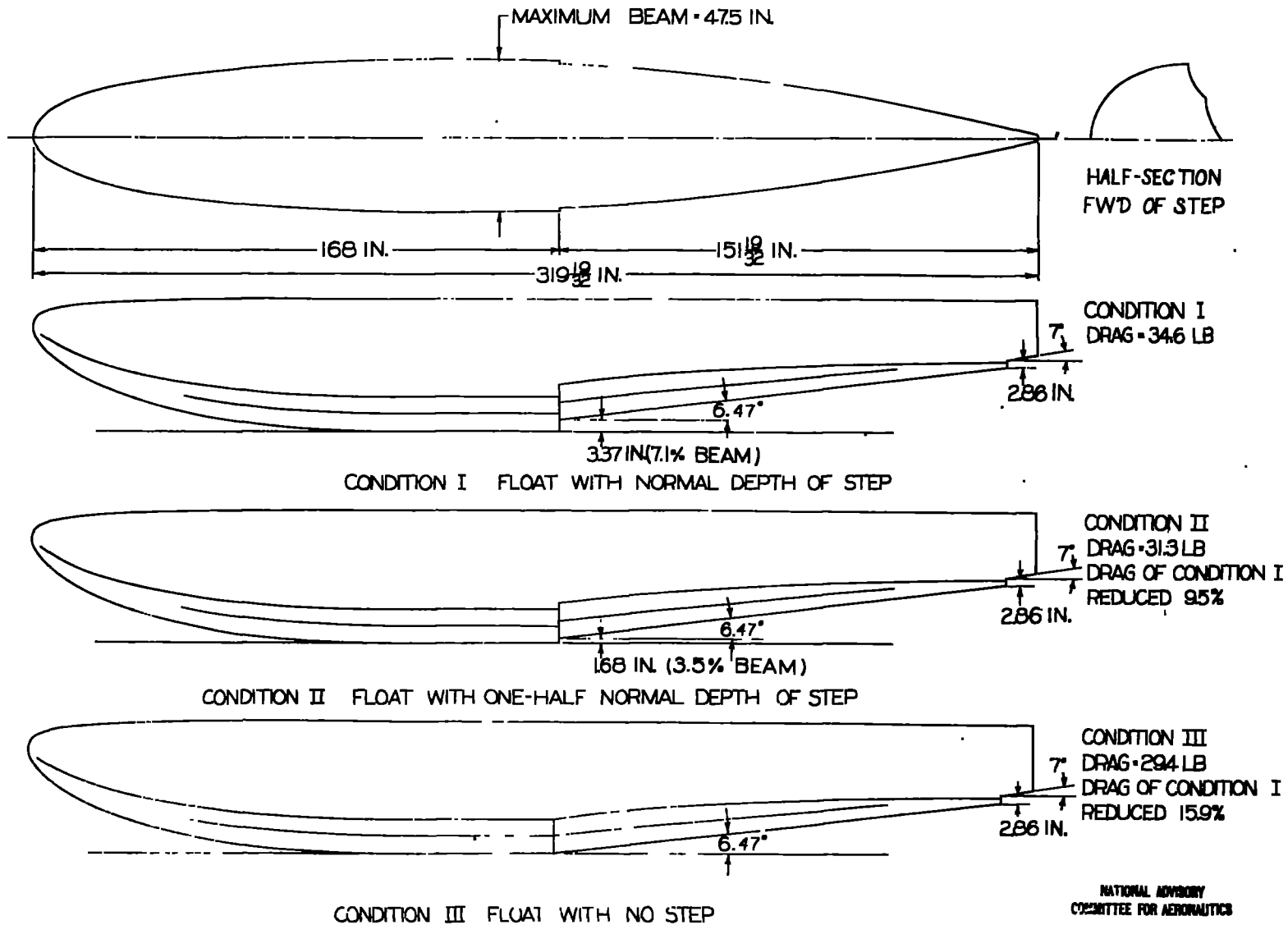

FIGURE 1.-MODIFICATIONS TO A FLOAT FOR THE PURPOSE OF SHOWING THE EFFECT OF THE DEPTH OF STEP ON AIR DRAG AT ZERO PITCH ($V=100$ MPH; $q=25.6 \frac{LB}{SQ FT}$).

NATIONAL ADVISORY
COMMITTEE FOR AERONAUTICS

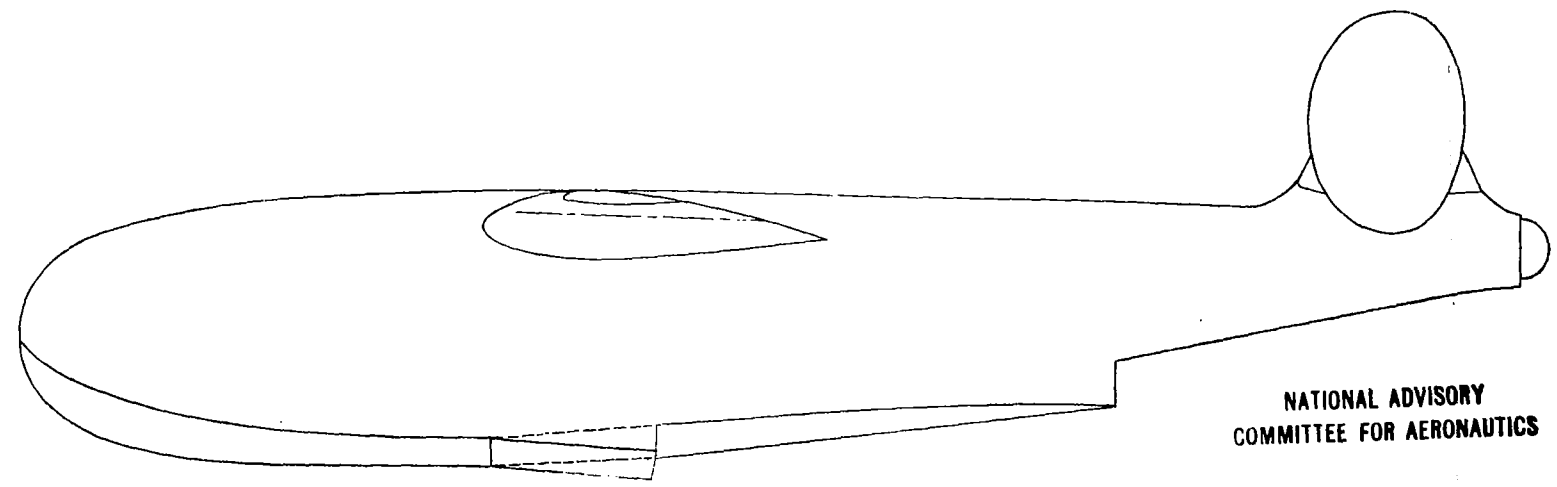

Figure 2.- Profile of model showing flap deflected. Dotted lines indicate flap in retracted position.

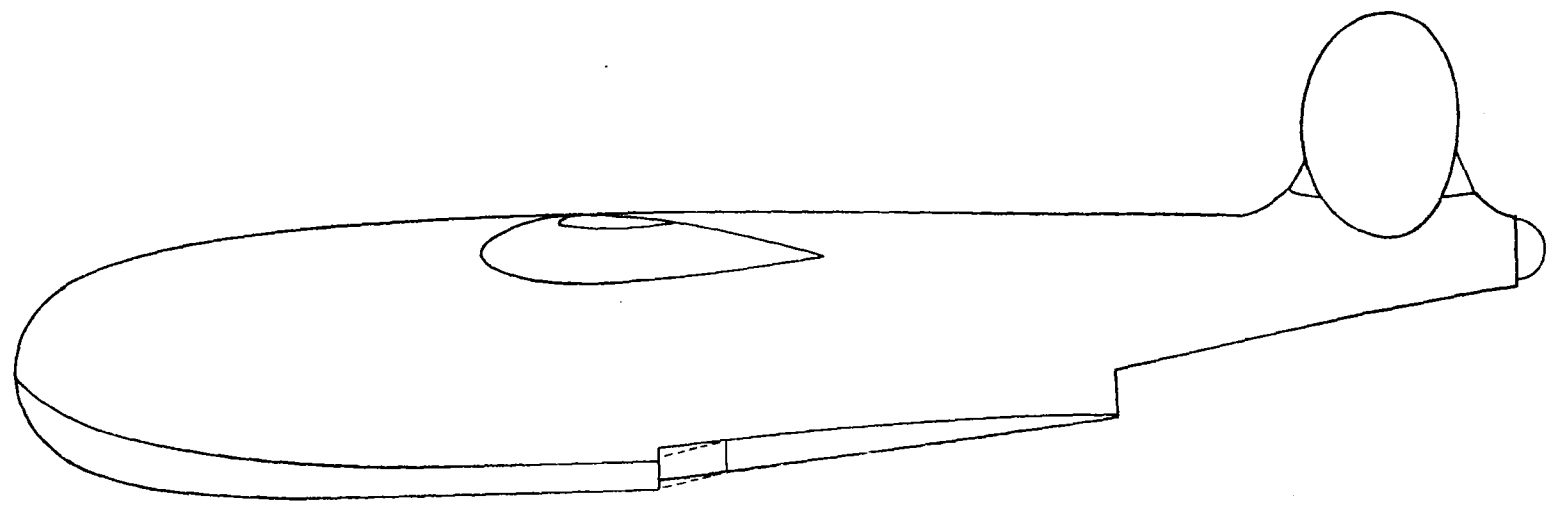
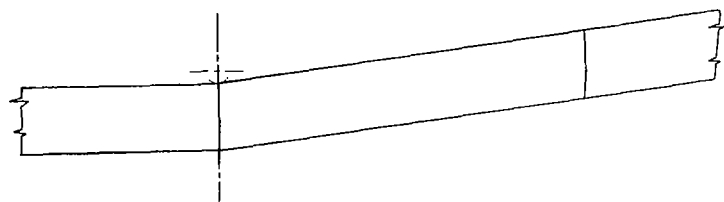
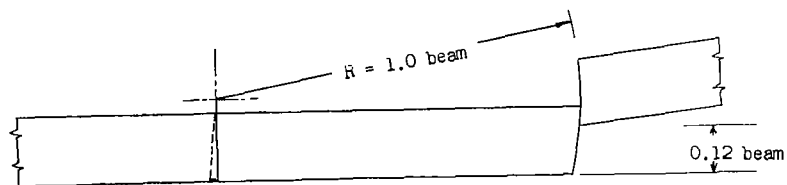

Figure 3.- Profile of model with transition flap behind step. Dotted lines show position of flap extended in flight.



(a) Flap retracted in flight. Here the keel and chine of flap fair into the afterbody.



(b) Flap deflected to form step.

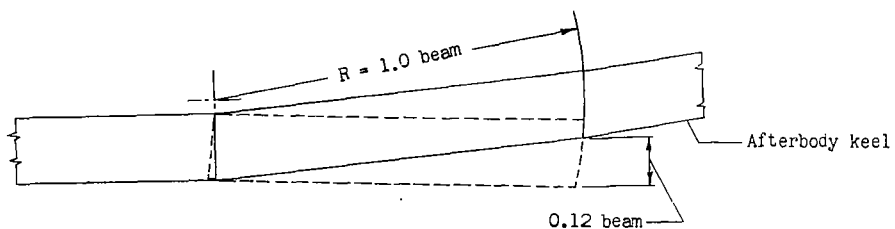

(c) Arrangement having larger angle of afterbody keel. Here the keel and chine of the flap when retracted are inclined at an angle between that of the forebody and afterbody. Dotted lines show flap deflected 2° below forebody keel.

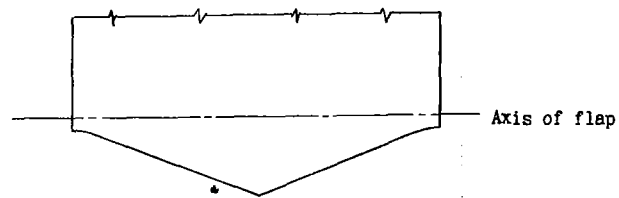

(d) Transverse section through hinge axis of flap.

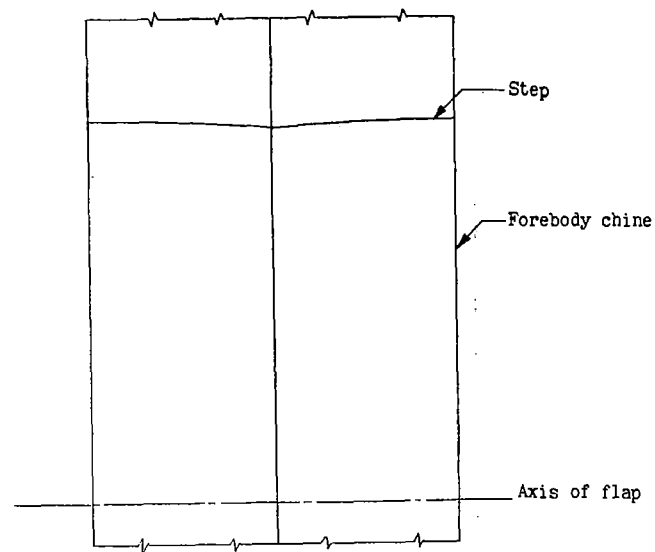

(e) Plan form of step. The departure from the conventional, straight transverse form is small.

NATIONAL ADVISORY
COMMITTEE FOR AERONAUTICS

Figure 4.- Sketches showing typical alterations to conventional lines resulting from use of two arrangements of the flap for providing a shallow step at low speeds and a deep step at high planing speeds.

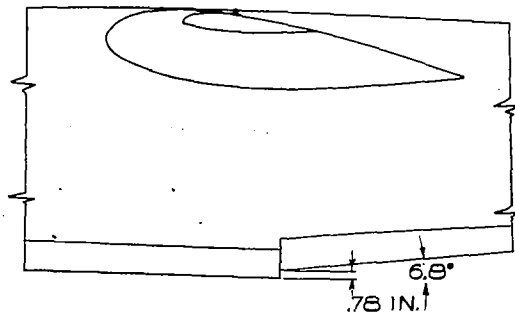

BASIC MODEL
MODEL 134A

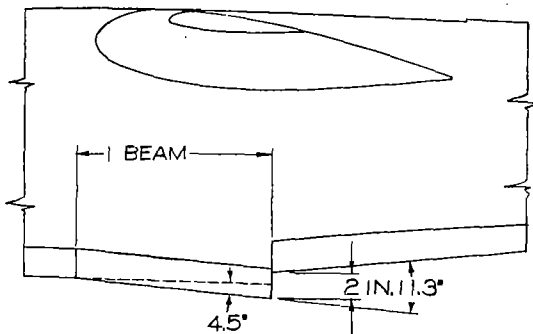

BASIC MODEL WITH PLANING FLAP. DEPTH OF STEP
INCREASED TO 2_{IN}(0.14 BEAM).
MODEL 134-PF

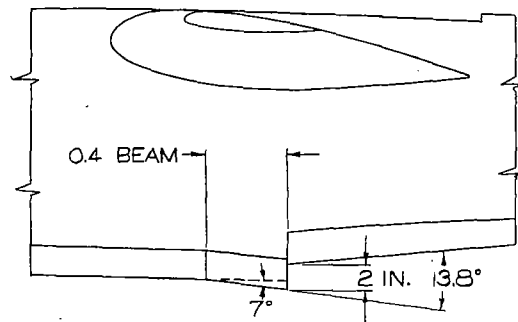

BASIC MODEL WITH PLANING FLAP. DEPTH OF STEP
INCREASED TO 2_{IN}(0.14 BEAM).
MODEL 134-PF-2

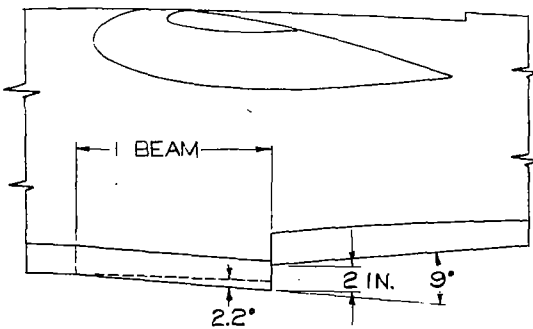

BASIC MODEL WITH PLANING FLAP. DEPTH OF STEP
INCREASED TO 2_{IN}(0.14 BEAM).
MODEL 134-PF-3

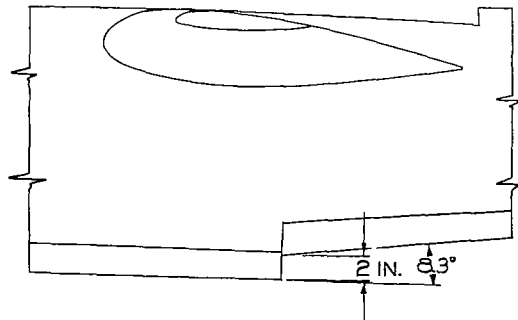

WING INCIDENCE OF BASIC MODEL DECREASED 2.5°
AND ANGLE OF AFTERBODY KEEL INCREASED 1.5°
DEPTH OF STEP = 2_{IN}(0.14 BEAM).
MODEL 134C

NATIONAL ADVISORY
COMMITTEE FOR AERONAUTICS

FIGURE 5.- MODIFICATIONS TO BASIC MODEL AT STEP.

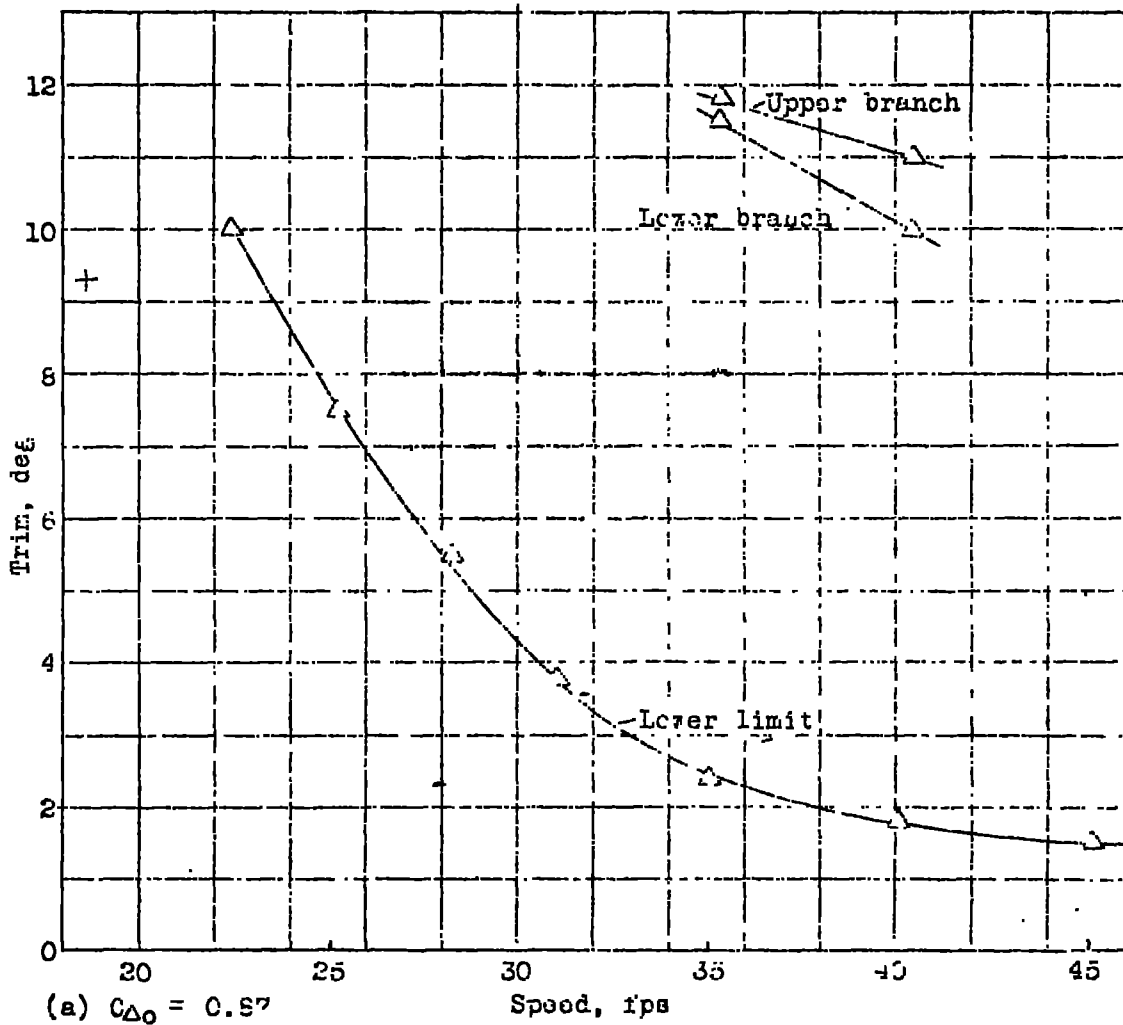
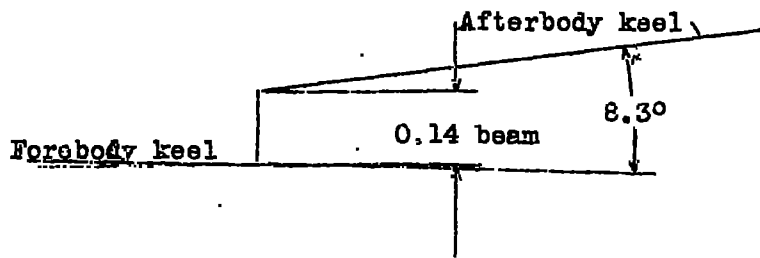

(a) $C_{\Delta 0} = 0.87$
 Figure 6 (a,b).-- Model 134C. Variation of trim limits with speed.
 Angle of incidence of wing decreased $2\frac{1}{2}^\circ$. Model without planing flap.

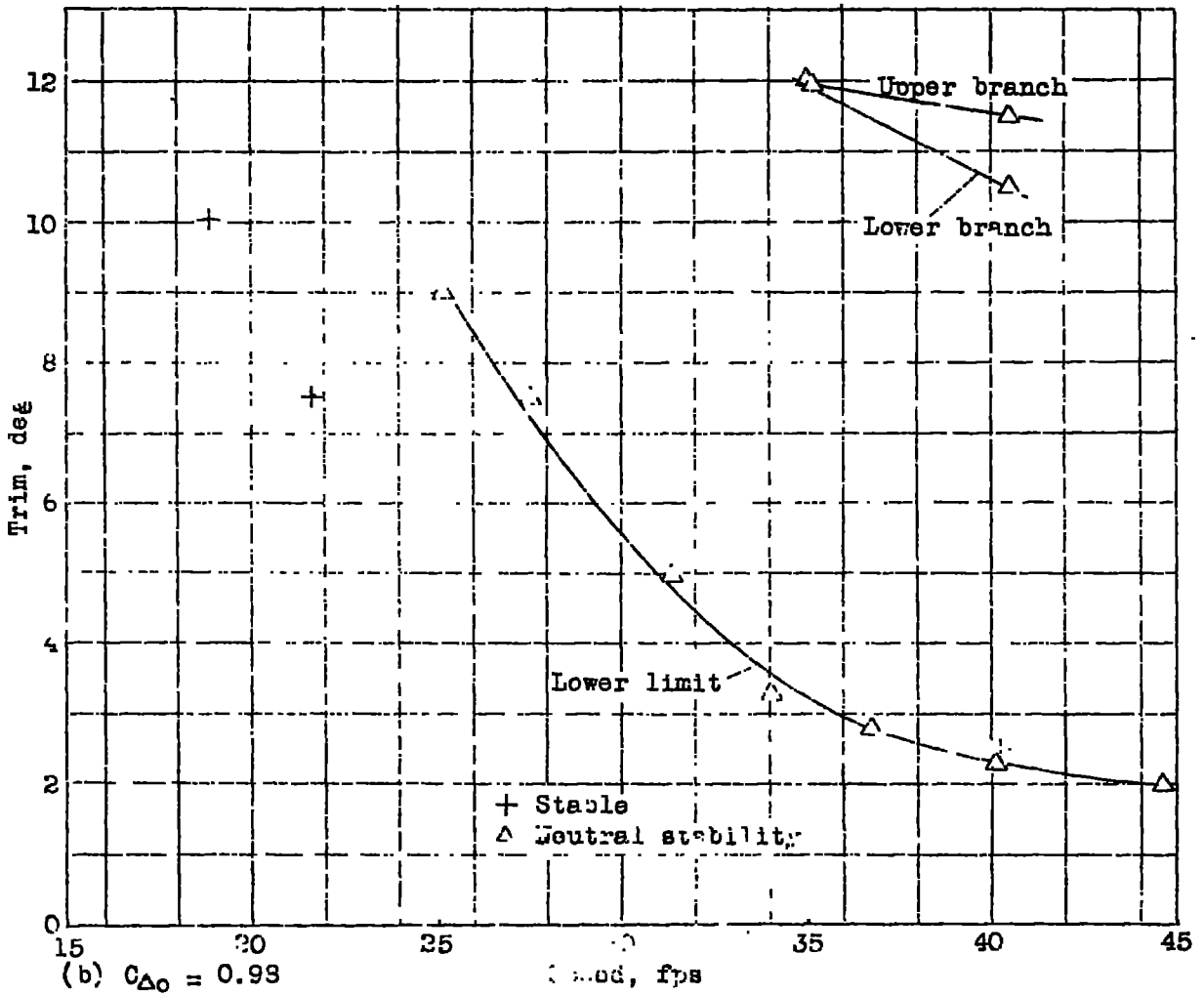

Figure 6b.- Concluded.

L-237

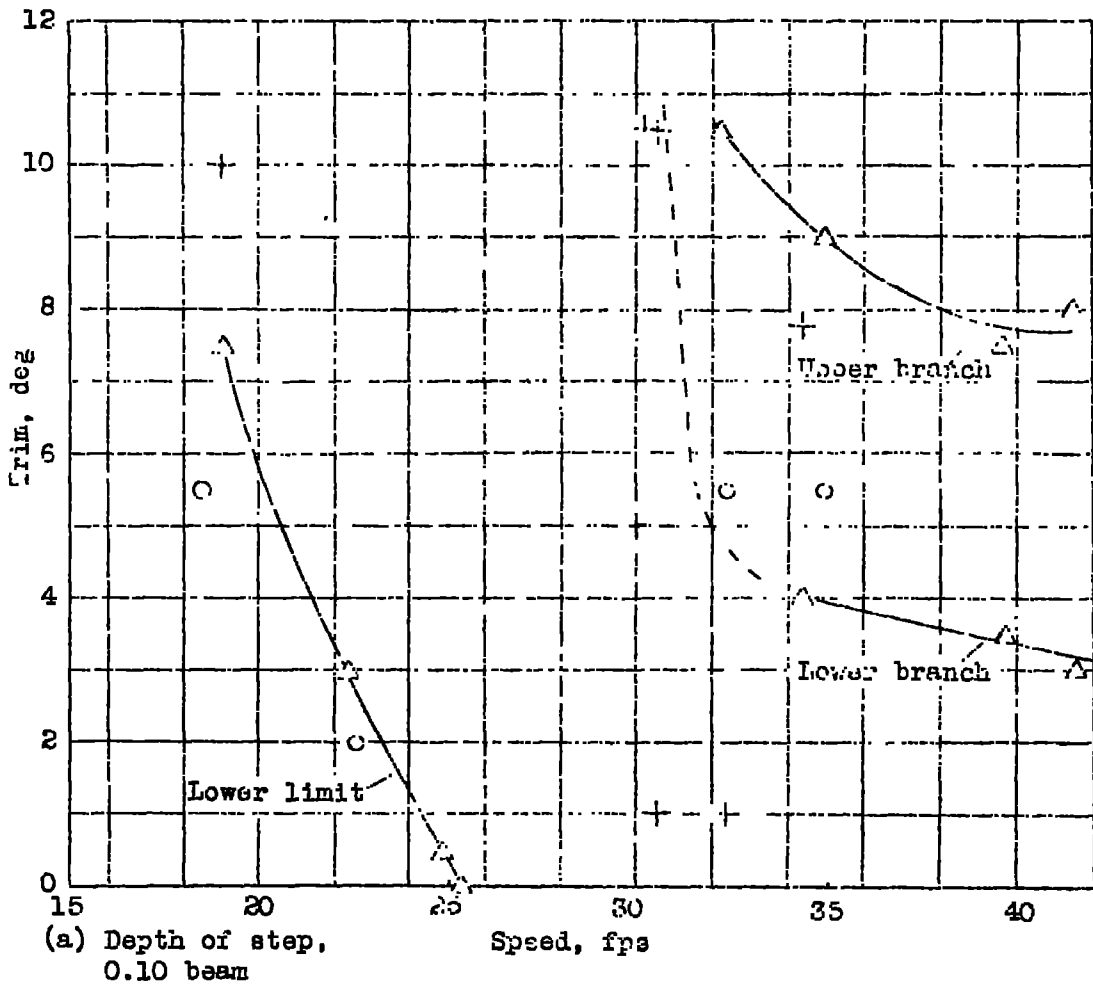
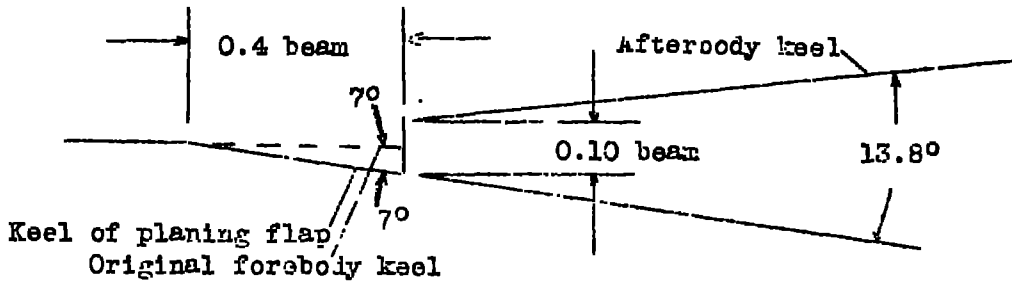

Figure 7 (a,b).- Model 134PF-2. Variation of trim limits with speed.
 $C_{\Delta 0} = 0.87$.

L-237

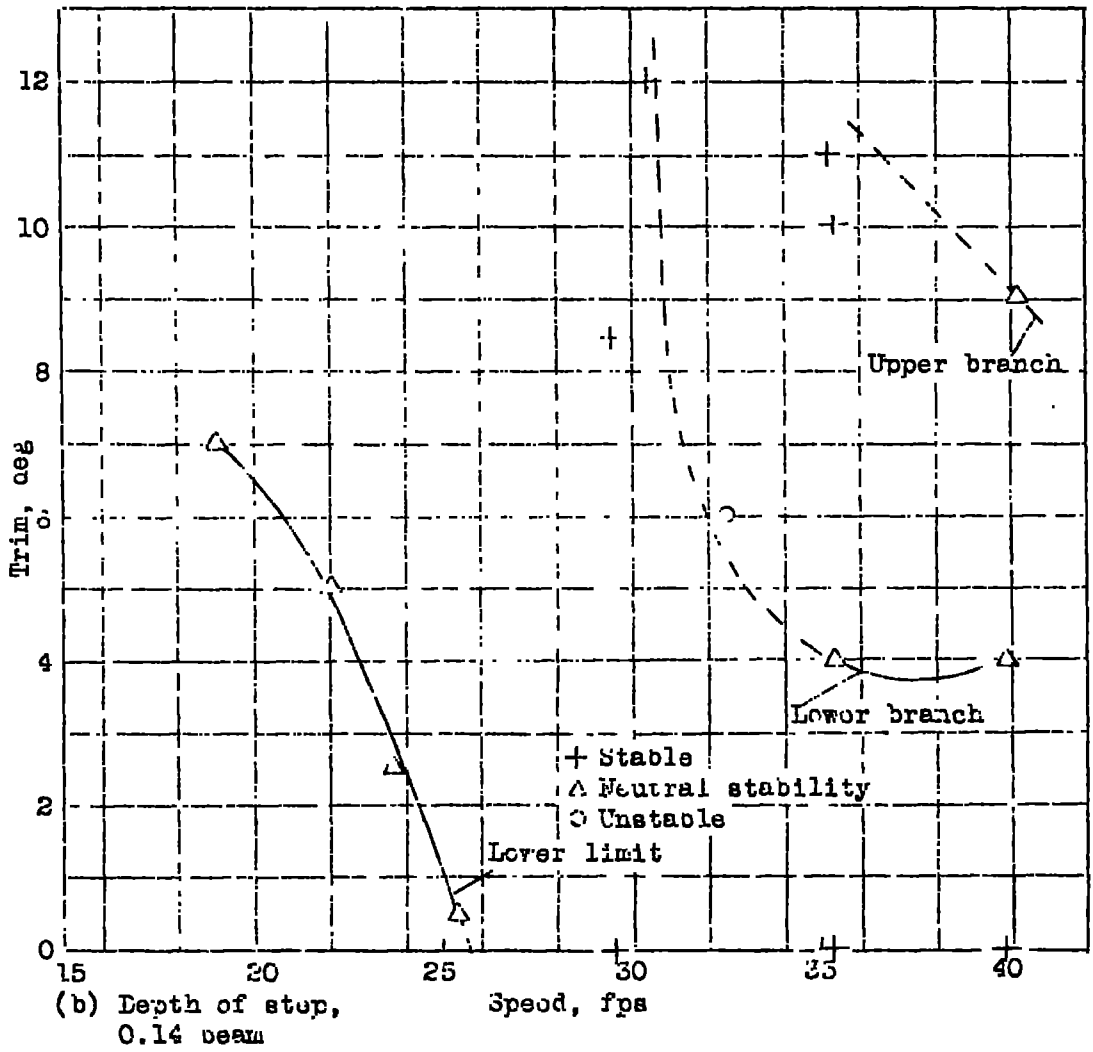

Figure 7b.- Concluded.

L-257

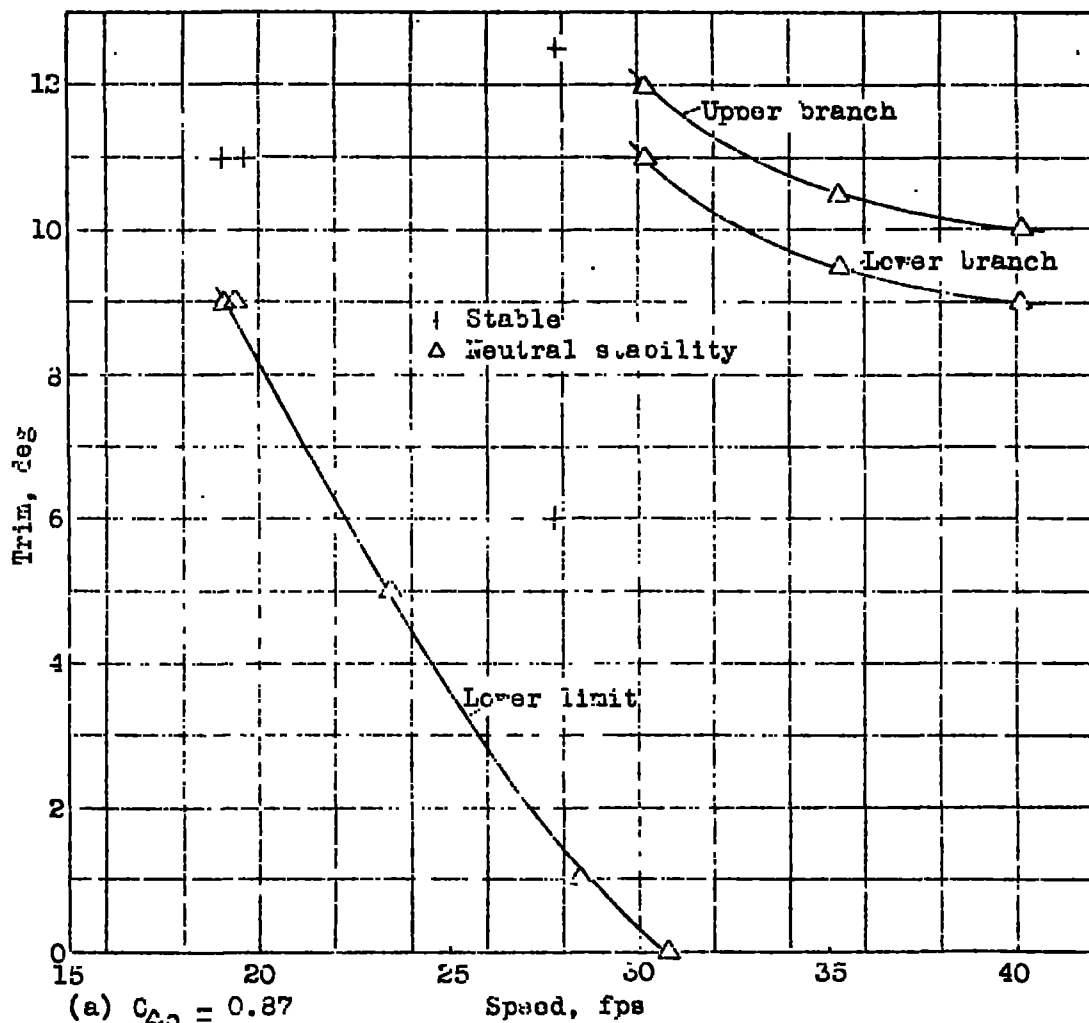

Figure 8 (a,b).-- Model 134PF-3. Variation of trim limits with speed. Depth of step = 0.14 beam.

L-237

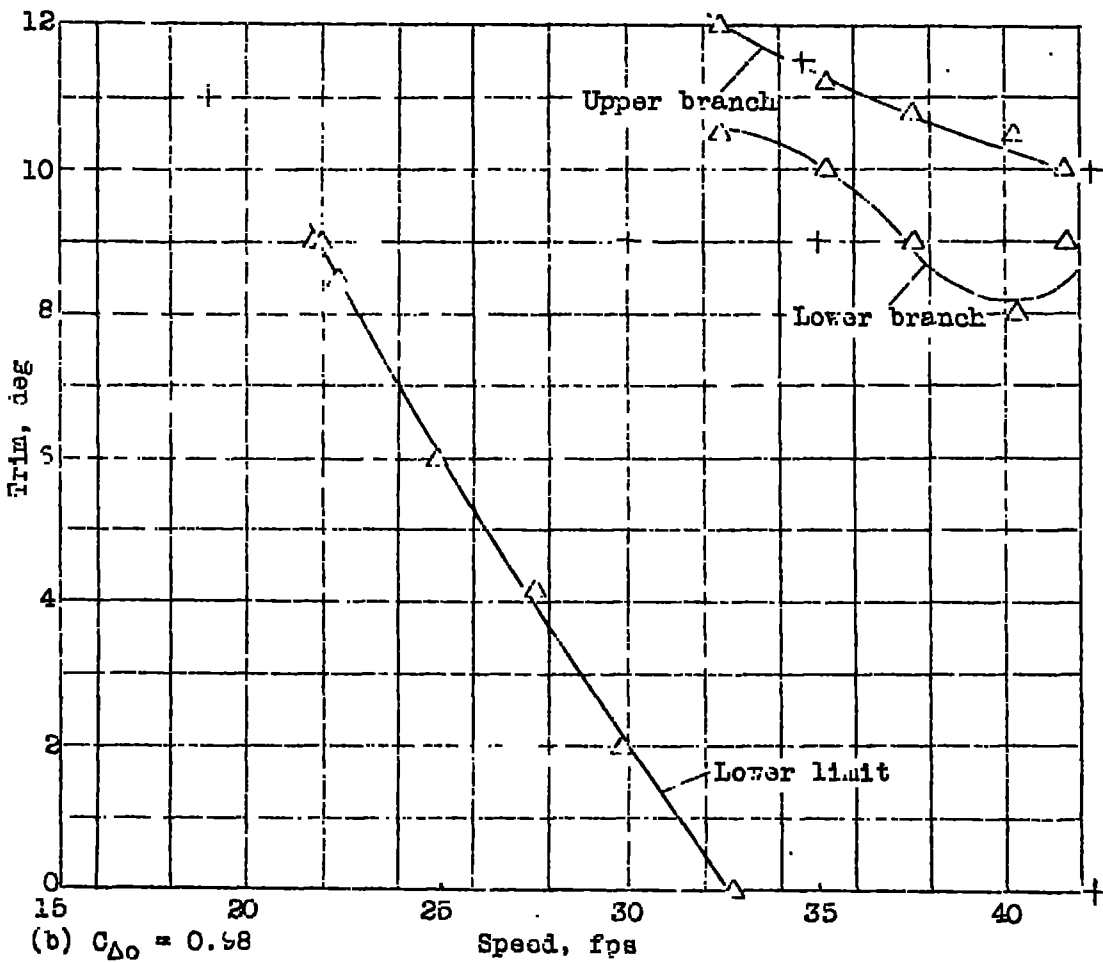
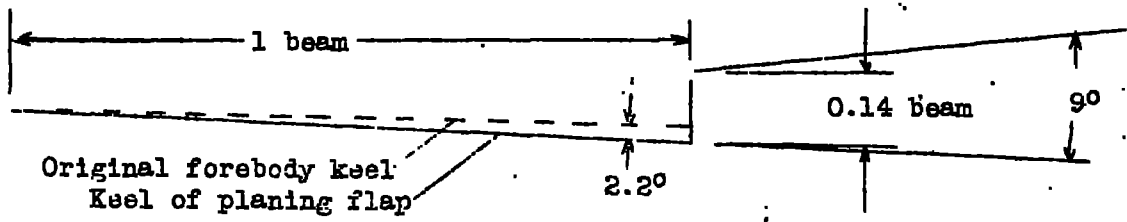

Figure 8b.- Concluded.

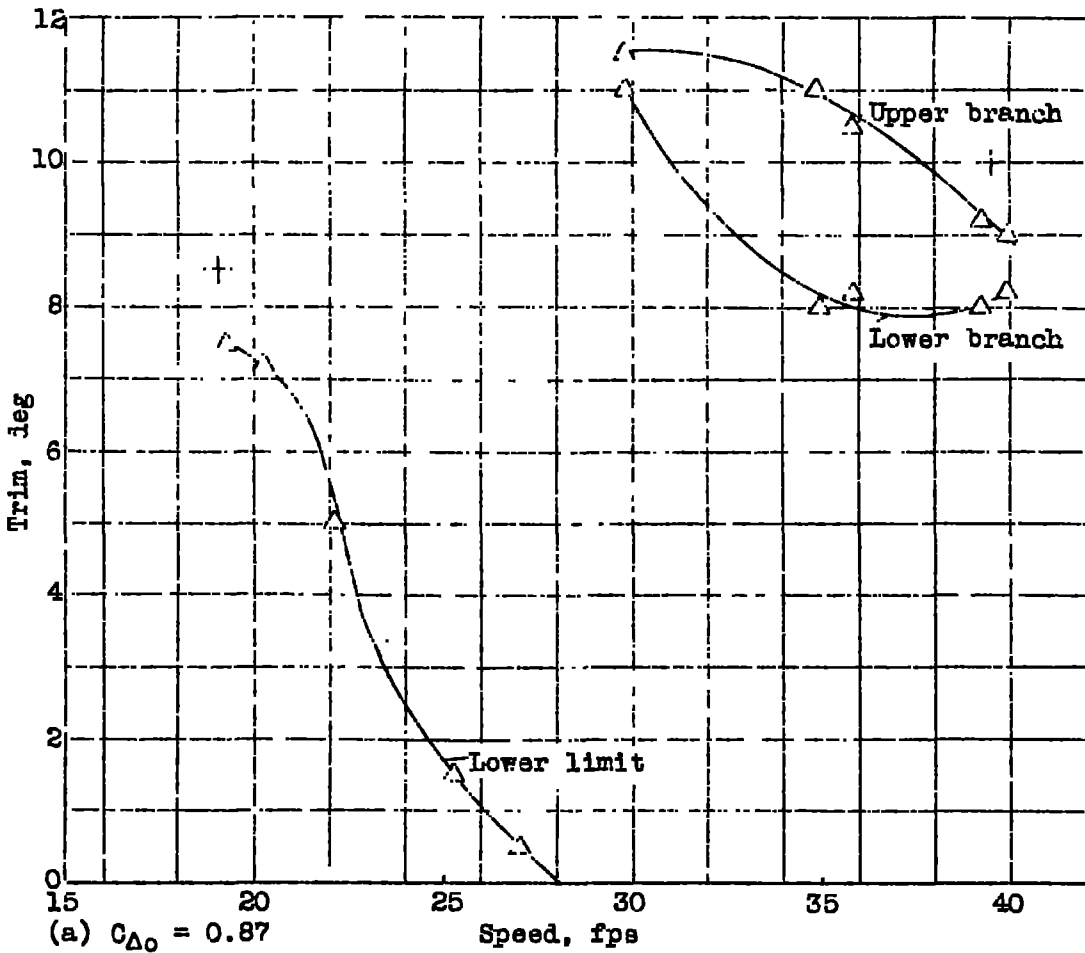
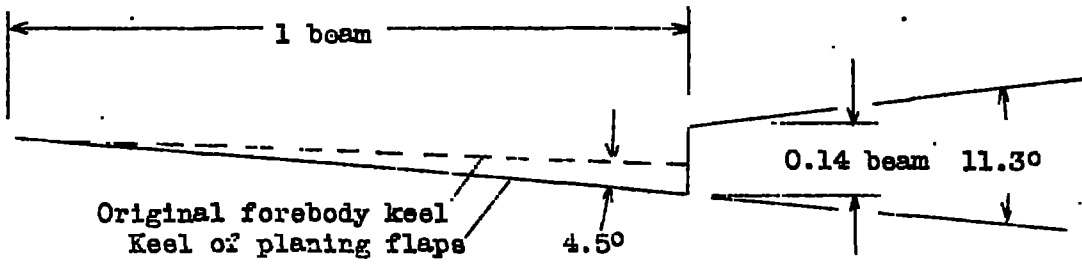

Figure 9 (a,b).- Model 134PF. Variation of trim limits with speed. Depth of step = 0.14 beam.

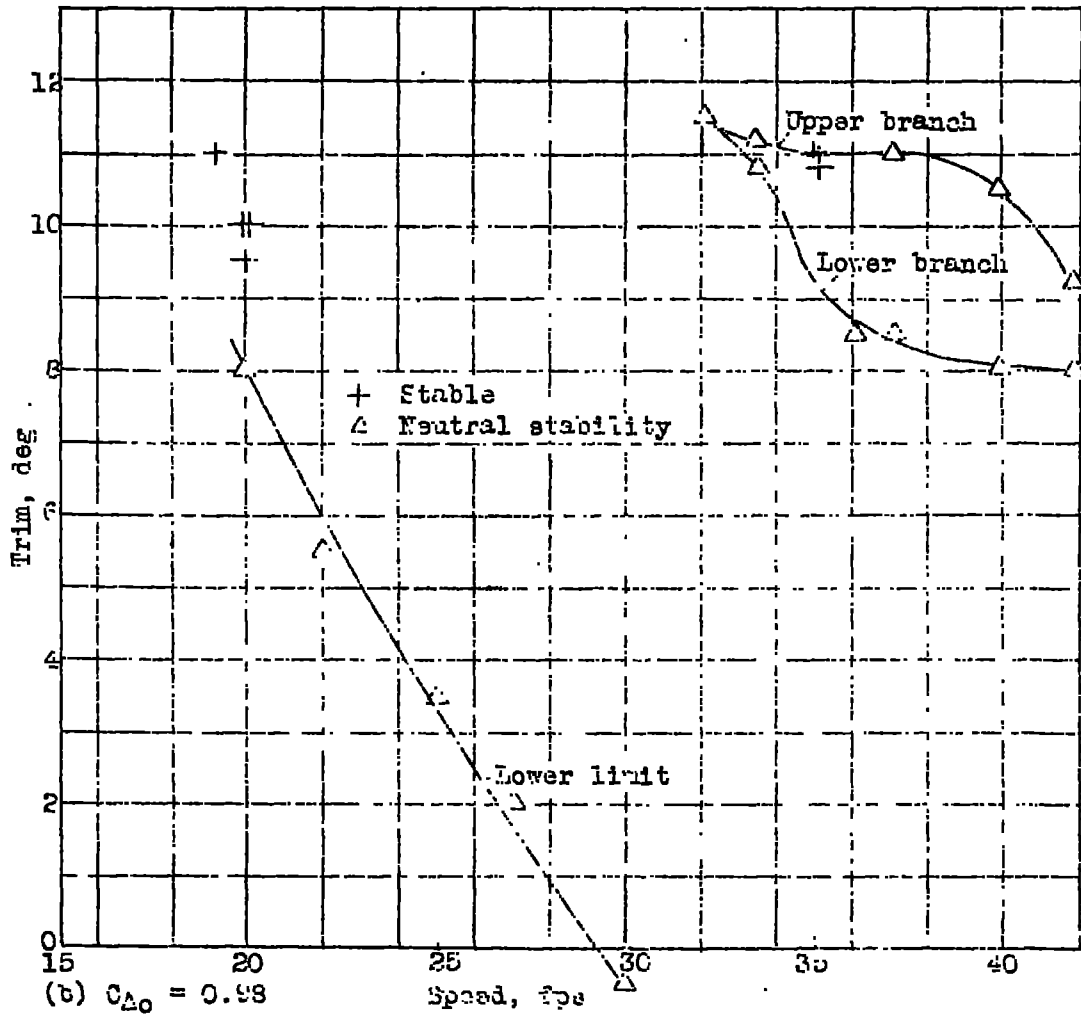

Figure 3b.- Concluded.

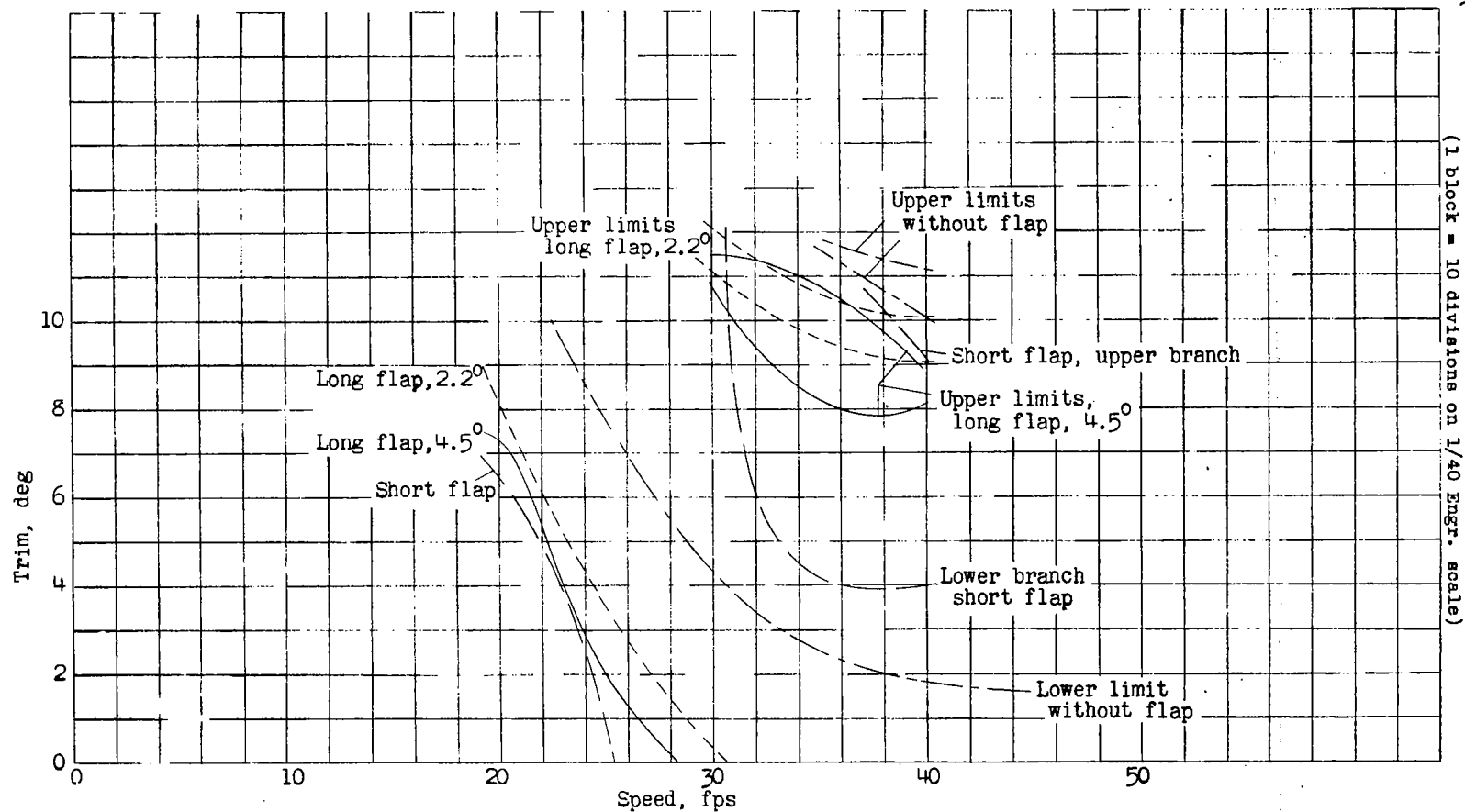

Figure 10.- Comparison of the trim limits of stability for the basic model and for the model fitted with three different planing flaps. $C_{\Delta_0} = 0.87$; depth of step = 0.14 beam; angle of keel of afterbody = 5.5° to base line.

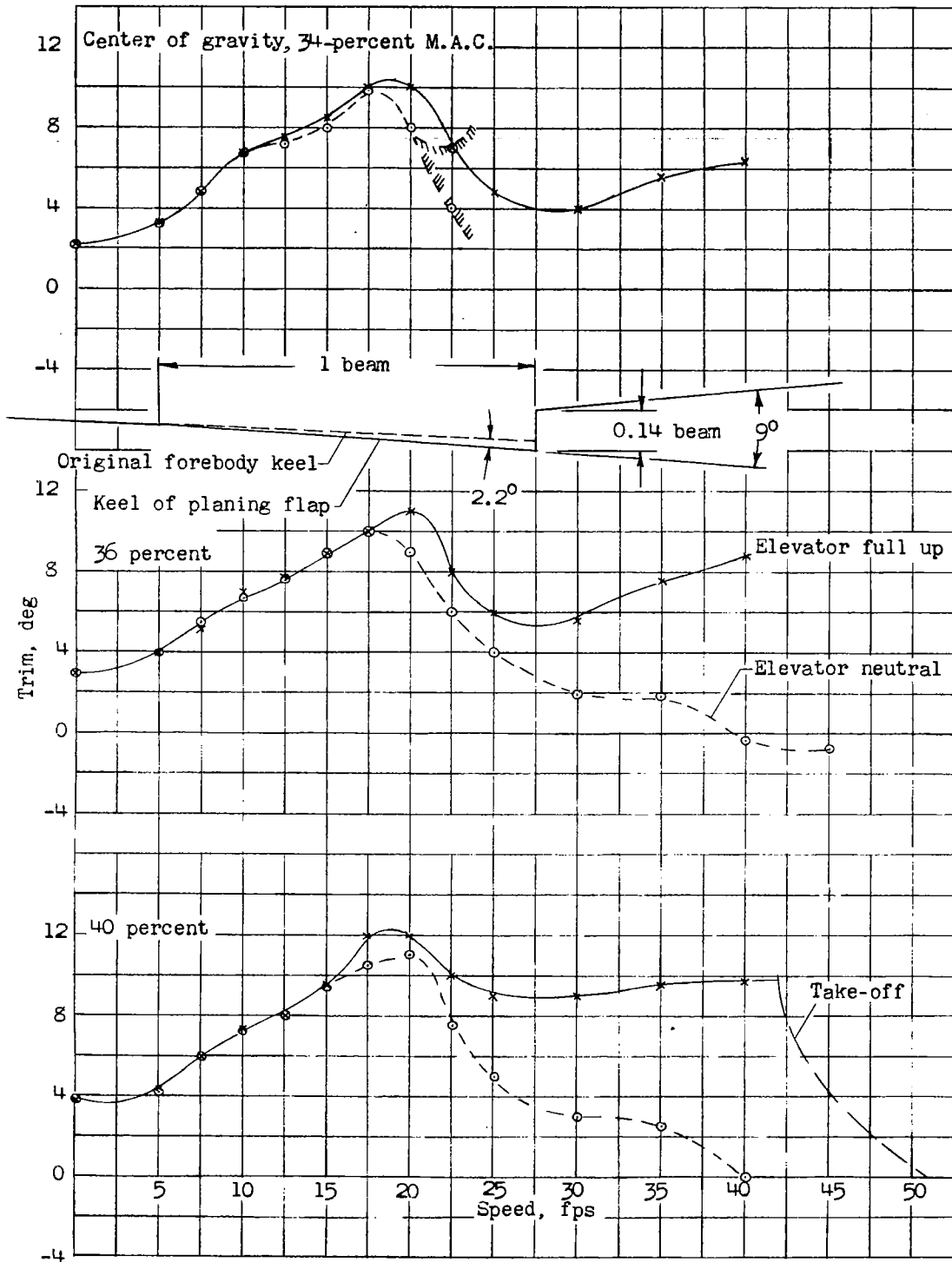

Figure 11.- Model 134PF-3. Variation of trim with speed. Step depth = 0.14 beam, stabilizer 5° up. $C_{D0} = 0.87$. Angle of planing flap = 2.2°; chord = 1 beam.

LANGLEY RESEARCH CENTER



3 1176 01354 2270