

Y3.N 21/5:8/967

TECHNICAL DEPARTMENT
HARTFORD PUBLIC LIBRARY
730 MAIN STREET
HARTFORD, CONN.

FEB 3 1941

m967

TECHNICAL MEMORANDUMS
NATIONAL ADVISORY COMMITTEE FOR AERONAUTICS

No. 967

STAGNATION TEMPERATURE RECORDING

By W. Wimmer

Ingenieur-Archiv
Vol. XI, no. 1, February 1940

Washington
January 1941

NATIONAL ADVISORY COMMITTEE FOR AERONAUTICS

TECHNICAL MEMORANDUM NO. 967

STAGNATION TEMPERATURE RECORDING*

By W. Wimmer

SUMMARY

The present report deals with the development of a thermometer for recording the stagnation temperature in compressible mediums in turbulent flow to within 1 to 2 percent error of the adiabatic temperature in the stagnation point ($A w_0^2/2 g c_p$), depending upon the speed.

This was achieved by placing the junction of a thermocouple near the stagnation point of an aerodynamically beneficial body, special care being taken to assure an uninterrupted supply of fresh compressed air on the junction together with the use of metals of low thermal conductivity, thus keeping heat-transfer and heat-dissipation losses to a minimum.

The practical possibility is underscored by the small effect of the flow direction.

The heat balance is evolved from an analysis of the conditions of similitude and a heat conductivity factor introduced which enables approximate predictions as to the reading accuracy on a similar body.

In other experiments the use of the plate thermometer was proved unsuitable for practical measurements by reason of its profound influence in the reading by the Reynolds number and by the direction of flow.

INTRODUCTION

If we attempt to measure the temperature of a compressible fluid with high flow velocity by introducing a thermometer, the flow is naturally disturbed and the

*"Die Messung der Stautemperatur." Ingenieur-Archiv, vol. XI, no. 1, 1940, pp. 1-23.

temperature will vary, depending upon the shape of the instrument, as illustrated in figure 1.

In point 1 the flow is undisturbed, the velocity w_0 and the true temperature of the flowing medium $T_1 = T_w$, or as is also termed the static temperature, prevails. In point 2, the stagnation point, the velocity becomes zero ($w = 0$). On streamline 2'2 ensues a pressure rise and hence a temperature rise, whence the stagnation-point temperature $T_2 = T_{st} > T_w$. If the compression is carried out without loss, we have, according to the laws of gases

$$T_{st} - T_w = A \frac{w_0^2}{2g c_p} \quad (1)$$

where $A = \frac{1}{427}$ kcal/mkg

$$g = 9.81 \text{ m/s}^2$$

and c_p the mean specific heat at constant pressure in kcal/kg °C

Thus the conditions are wholly similar to those in pressure measurements where

$$P_{tot} - P_{stat} = P_{dyn} = \gamma \frac{w_0^2}{2g}$$

so long as w_0 is small in relation to the velocity of sound.

We therefore write:

$$T_{st} = T_{tot} \quad \text{total temperature (stagnation temperature)}$$

$$T_w = T_{stat} \quad \text{static temperature}$$

$$T_{st} - T_w = T_{tot} - T_{stat} = T_{dyn} = A \frac{w_0^2}{2g c_p} \quad \text{dynamic temperature}$$

Point 3 lies in the zone of disturbance of the body; hence $w \neq w_0$. The temperature in point 3 is

$$T_3 = T_{stat} + A \frac{w_0^2 - w^2}{2g c_p}$$

If $w < w_0$, then $T_3 > T_{stat}$, and if $w > w_0$, then $T_3 < T_{stat}$.

In point 4 every stagnation effect has disappeared, but there is a temperature increase ΔT_r because of the friction in the boundary layer, so that

$$T_4 = T_{stat} + \Delta T_r$$

The purpose of the measurement always is the determination of the true temperature $T_1 = T_w = T_{stat}$. But the installation of a test instrument is always accompanied by a disturbance of the temperature field through stagnation effect or friction. The first can be followed mathematically conformably to equation (1), but not the friction effect. For this reason it has been customary up to now, apart from a few earlier attempts, to measure the stagnation temperature. However, such measurements are inevitably afflicted with errors: The instrument does not register T_{tot} but another temperature T_a , which is always lower than T_{tot} but higher than T_{stat} :

$$T_{stat} < T_a < T_{tot}$$

The instrumental error is denoted by the quantity

$$\Delta T = T_{tot} - T_a \quad (2)$$

and computed in percentage of the difference $T_{tot} - T_{stat} = A \frac{w_0^2}{2gcp}$, i.e., of the dynamic temperature

$$f = 100 \frac{T_{tot} - T_a}{T_{tot} - T_{stat}} = 100 \frac{\Delta T_c}{A \frac{w_0^2}{2g}} \quad \text{in percent} \quad (3)$$

As indicating accuracy a of the instruments, we use the quantity

$$a = 100 - f = 100 \frac{T_a - T_{stat}}{T_{tot} - T_{stat}} \quad \text{in percent} \quad (4)$$

Thus the indicating accuracy gives the percent of dynamic temperature rise $T_{dyn} = T_{tot} - T_{stat}$ of the instrument actually recorded. The closer a approaches 100 percent the better the instrument.

Attempts to measure the temperature at high velocities go back several decades to Stodola (reference 1), who, in measurements of the temperature drop along the axis of

a nozzle with a mercury thermometer, found that the theoretical temperature is not reached by superheated water vapor. His explanation was "that friction on the walls of the thermometer creates heat, the nozzle walls become hotter through conduction than the steam flowing past and so supply heat to the thermometer by radiation," as a result of which the indicated temperature is too high. Since the publication gives no experimental values, it is unfortunately impossible to determine the discrepancies from the true temperature on the mercury thermometer.

In contrast, Batho (reference 2) in his measurements along the axis of a nozzle but with wet steam and thermocouples of 0.2 millimeter of iron and German silver wire, achieved an almost exact reading of the true temperature T_{stat} . By an expansion of 6.657 atmospheres and about 96 percent specific vapor content to 1.125 atmospheres, that is, a velocity of 766 meters per second at the nozzle exit, the maximum recorded discrepancy is 2° C, which with relation to the temperature gradient between stagnation and true temperature corresponds to an error of only 3 percent of the true flow temperature T_{stat} .

Nusselt (reference 3) used air instead of steam in his investigations. He stretched thermocouple wires in the nozzle axis, the junction of which was situated in the center of the orifice circle of the nozzle and which consisted of 0.1 millimeter and 0.5 millimeter copper-constantan or 0.5 millimeter iron-constantan. He measured the temperatures at the nozzle exit at different initial pressures. Regarding these tests, he simply remarked that "the temperature of a gas at supersonic velocity cannot be measured with a thermocouple." When using the values given in tables 14, 19, 20, and 21 of his report to compute the velocity at the nozzle exit and the temperature difference between T_{tot} and indicating temperature T_A , a clear picture of the accuracy of the test arrangement is obtained. Figure 2 shows $\Delta T = T_{tot} - T_A$ plotted against the velocity. The indication values for the thinner (0.1 mm) copper-constantan wires are much closer to the true gas temperature because the flow is considerably less disturbed. The error relative to (3) is about 20 percent for the thinner wires and about 15 percent of the difference $T_{tot} - T_{stat}$ for the thicker; at maximum velocities the discrepancy is even less. The test values of the iron-constantan wire are difficult to arrange because of scattering, due probably to the nonhomogeneity

of iron; at velocities above 470 meters per second they have about the same degree of accuracy as the heavier copper-constantan thermocouple. Similar experiments with the wires stretched diagonally to the gas flow before the nozzle orifice, yielded the same results.

The dissimilar aspects of Stodola and Nusselt on the one hand and of Batho on the other, prompted Müller (reference 4) to check both experiments. In his first attempt with a pitot with dome-shaped head, containing two junctions, one in the vertex of the dome, the other at the side, and using superheated steam as medium, he endeavored to measure T_{tot} and T_{stat} simultaneously at supersonic velocity. At 890 meters per second velocity he ascertained an error of from 13° to 25° C relative to the stagnation temperature at the forward stagnation point or, on the basis of a heat gradient of only 6.5, of as much as 12 percent discrepancy from the stagnation temperature. The difference of the lateral from the forward junction amounted to 3° C only. Müller attributes the failure of the lateral junction to the compression wave which envelops the dome of the pitot tube and he believes that at subsonic velocity both the static and the stagnation temperature are correctly indicated, despite the fact that Nusselt (fig. 2) had already ascertained at a Mach number of 0.72 about the same error as at supersonic velocity. Experiments with thermocouple wires arranged axially in the nozzle yielded practically the same divergence from the stagnation temperature as before, although Müller had remedied all supposed defects of the test lay-out (insulation of wires, determination of the entrance of ionization of steam, different wire thicknesses, different form of junction). One success that he was able to achieve, however, when he conducted steam of different states through the nozzle and effected the measurement at the exit section: namely, with saturated and with superheated steam the stagnation temperature also became manifest, but with wet steam he achieved the looked-for true temperature. This led him to the following assumption: "with wet steam - the same as by Batho - the fluid is precipitated on the wire, the fluid assumes the condensation temperature of the surrounding steam, in consequence of which the thermocouple indicates the temperature corresponding to the steam pressure. But, if the steam is superheated so as to approach the gas state - as by Nusselt - the laws for gases at supersonic velocities are applicable, i.e., any slight obstruction, no matter how small, creates disturbances. Shocks and stagnation effects ensue on the wire,

as a result of which a temperature is always measured which corresponds to the stagnation temperature. If the expansion reaches into the wet steam zone the indication is nevertheless that of the stagnation temperature." This phenomenon is explained by the fact that a central nucleus in the nozzle remains superheated as far as the end of the nozzle, and the moisture settles on the walls. While heretofore it had been endeavored to ascertain the temperature curve at expansion in a nozzle experimentally and then found that the recorded temperature corresponds approximately to the stagnation temperature, it is now intended to approach the stagnation temperature as closely as possible or to establish the accuracy for some kind of test arrangement. Thus Brun and Vernotte (reference 5) attempted a direct measurement of the heat of a thermocouple through a gas flow by mounting the hot junction on the outside and the cold junctions of their 0.3 millimeter constantan-manganese thermocouples on the inside on a disk which they let revolve in air. The thermal force was collected by brushes, the heat of the inside junction amounting to a mere fifth of the velocity being disregarded. The heat for 80 meters per second circumferential speed amounted to 2.7° C, which corresponds to an error of 15 percent, or the same result as obtained by Nusselt with 0.5-millimeter copper-constantan wires.

Essential is the knowledge of accurate temperatures for the determination of heat transfer coefficients such as were carried out by Guchmann and his collaborators (reference 6), by Jung (reference 7), and Meissner (reference 8) at high velocities. Guchmann recorded air temperatures up to 0.95 Mach number with 0.5-millimeter-thick copper-constantan and 0.3-millimeter-thick tin-constantan thermocouples. The indicating error was obtained by different determination of the heat content of the air - once from amount and measured stagnation temperature, another time from the supplied electrical energy less the losses - to 4.4 to 15.4 percent depending upon the velocity. The fluctuation of the accuracy is explained by the method of error determination. Jung developed a special stagnation-point thermocouple for his experiments, consisting of 0.1-millimeter-thick iron-constantan wire; the junction was 0.5 millimeter aft of the mouth of a small, slightly conical glass tube. He attached no importance to any eventual errors but failed to give their exact amount. Meissner lastly attempted to solve the problem of temperature at high velocities on the whirling arm, like Brun and Vernotte. He mounted two opposite tubular steel arms on the axis of

a gasoline engine; the thermocouples of 0.2-millimeter-thick copper-constantan wires at the ends of the arms, one thermocouple being suspended freely in the air, the other housed within a pipe of 90 millimeters inside diameter. Then he ascertained the indicating accuracy of these thermocouples. The error for the free-rotating thermocouple amounted to 26 to 51 percent at 125 meters per second, and from 32 to 44 percent at 150 meters per second, averaging 38 and 35 percent, respectively. The corresponding values for the thermocouple in the pipe averaged 36 percent at 106 meters per second and 30 percent at 158 meters per second. From this experiment Meissner concluded that "a specified magnitude of junction and a certain disposition of it is not necessary." The marked discrepancies within one test series and the completely dissimilar results from those of other research workers are probably due to the test method, as Knoblauch and Hencky (reference 9) themselves claim the method of collecting thermal force by brushes to be extremely inaccurate.

To complete the list we should further include several other publications which quote the accuracy of the test equipment employed. Von der Nüll and Garve (reference 10) cite an error of from 16 to 18 percent for thermometers with cylindrical mercury bulb. Eckert (reference 11), in his experiments with superheated water vapor, finds an error of from 20 to 30 percent at 200 to 400 meters per second speed with thermocouples, while F. E. Schmidt (reference 11) reports that a thermocouple in the stagnation point of a body with aerodynamically favorable profile gives an error of 10 percent in the dead air zone of a sphere and for a free thermocouple in the air stream an error of 20 percent and still greater errors on the inside of a perforated body.

The sole theoretical report on the subject available is that published by Polhausen (reference 12), who by estimation of the relative orders of magnitude of the separate terms of the hydrodynamic differential equation in the zone of a boundary layer adjacent to a fixed body achieves a simplification of the differential equation for the temperature of the fluid in proximity of a fixed body. This enables him to compute the heat removal from a thin plate by a parallel flow, as well as to determine the temperature of such a flow from the reading of a plate thermometer. The correction $\Delta(\theta)$ by which the reading T_1 of a plate thermometer must be reduced in order to obtain the true temperature of the flow T_{stat} is for gases:

$$\Delta(\sigma) = \frac{1}{4} (T_{\text{tot}} - T_{\text{stat}}) \beta(\sigma)$$

where $T_{\text{tot}} - T_{\text{stat}}$ is the temperature rise corresponding to adiabatic expansion. Thereby $\beta(\sigma)$ is chiefly

dependent upon the nondimensional $\sigma = \frac{\eta g c_p}{\lambda}$ (hence

equal to the Prandtl number Pr), where η is the dynamic viscosity in kg sec/m^2 and λ the heat conductivity in $\text{kcal/m sec } ^\circ\text{C}$. This derivation, however, holds only for laminar flow; for turbulent flow neither theoretical nor practical studies with the plate thermometer have been made so far.

On analyzing the available data, it becomes apparent that the indicating accuracy for some test arrangements has been established even though some contradictory views still prevail, but no effort has so far been made to measure one of the two temperatures by a suitable method direct, in spite of their extremely essential importance for experimentation on heat transfer, steam turbines and special boilers, and for the determination of the speed of compressible mediums, where besides the two pressures, the temperature also is very essential.

Accurate measurement of the true temperature of the flowing medium is likely to be almost impossible with the present day means; at any rate any method attempting to achieve this end by insertion of any kind of instrumental into the flow is abortive since it is always accompanied by a change of some kinetic flow energy into potential energy, i.e., heat. On the other hand, a properly designed test instrument, devoid of radiation and heat transfer losses, appears promising.

The problem of the present study is:

- 1) To develop an instrument which records the stagnation temperature with a maximum accuracy;
- 2) To ascertain whether the plate thermometer has the same indicating accuracy in turbulent flows as established by Pohlhausen for laminar flow and, if so, its practical use.

EXPERIMENTAL SET-UP

The experiments were made behind a nozzle where the marked contraction of the flow section before the test length assures the most uniform velocity distribution (reference 13). The air stream passes from a blower through the nozzle into an exit cone (fig. 3). The test length is open, making observation of the phenomena possible during the tests.

The blower is driven from an alternating-current shunt-wound motor. The blower speed and hence the air speed is controlled by the motor rpm. Fluctuations in the line produced only minor speed changes in the test length and were unavoidable.

To insure uniform temperature and speed during a test series, a tubular cooler mounted between blower and nozzle chamber served at the same time as flow straightener. A system of pipes and valves in conjunction with a cooling tower or a condenser assures the necessary fresh water and cooling.

Uniformity of flow in the jet is secured by the contraction in the nozzle. The free passage diameter in the nozzle chamber, that is, before the contraction, is 5.12 times that of the nozzle; the chamber section is to the nozzle section as 26.25 to 1. By this sectional contraction of 26.25 to 1, which for incompressible fluids means a 26.25-times velocity increase in the nozzle, the kinetic energy entering the nozzle is only the 687th part of the stream energy in the jet, the remaining 686/687 of the flow energy corresponding to the pressure energy in the space before the nozzle contraction.

The prediction of the accuracy of temperature-recording instruments necessitates, aside from the temperature data, that of the velocity in the jet. This was computed from the relation

$$w = \sqrt{2g \frac{\kappa}{\kappa - 1} R T_0 \left[1 - \left(\frac{p_1}{p_0} \right)^{\frac{\kappa - 1}{\kappa}} \right]} \quad (5)$$

With $g = 9.81 \text{ m/s}^2$, $\kappa = 1.41$, and gas constant $R = 29.27 \text{ mkg/kg}^\circ\text{K}$,

$$w = 44.48 \sqrt{1 - \left(\frac{p_1}{p_0}\right)^{0.291}} \quad (6)$$

The velocity w is therefore dependent upon the ratio of the static pressure in jet p_1 to the chamber pressure p_0 . The latter was determined through a pressure tap (fig. 4) and read on a U-tube in mm Hg. A pressure ring with aerodynamically favorable profile was mounted in the chamber for a check; it showed a difference of only a few mm Hg relative to the pressure tap, an amount which corresponds approximately to the dynamic pressure of the inflow velocity, which is not contained in p_0 .

The static pressure in the test length is not equal to atmospheric pressure; because of the stagnation before the exit cone, part of the chamber pressure is not changed to speed. Thus, in the calculation p_1 should not be expressed by the barometer reading but rather by a slightly higher pressure which first is to be determined. Since the temperature recording tests with instruments permitted no introduction of a pressure instrument in the jet at the same time, the static pressure at the test station had to be obtained by preliminary tests in respect to the nozzle chamber pressure. The error introduced by a different shape of the temperature instrument from the pressure instrument was unavoidable. In order to find, at first, the point of lowest pressure in the jet axis between nozzle orifice and exit cone (distance 170 mm) the pressure was recorded with a static pressure head with four holes of 0.5 mm diameter at a distance of 15 d from the tip. The lowest pressure at initial pressures p_0 of 396 mm Hg and 214 mm Hg were ascertained 40 mm ahead of the nozzle orifice, amounting to about 3 percent of p_0 . Care had to be taken in the subsequent tests to insure the location of the test point always 40 mm ahead of the nozzle orifice. The dependence of the static pressure on the initial pressure p_0 (fig. 5) at this distance was also measured with the pressure head and checked by a Prandtl pitot tube. The remarkable fact is the absence of proportionality between 250 and 400 millimeters mercury column as nozzle chamber pressure, but a sudden rise and just as sudden a drop in static pressure. This phenomenon is associated with increased noise; i.e., a high, singing noise accompanies it. The cause is probably due to an oscillation about the velocity of sound at several points of the instrument; at any rate the phenomenon is absent when the flow is undisturbed. On the basis of the pressure recording method described, the velocity can be ac-

curately ascertained at 0.5 m/s, i.e., to within 1/2 to 1/6 percent between 100 and 310 m/s.

The temperature was recorded with 0.5-mm-thick copper-constantan thermocouples and later on also with 0.5-mm-thick iron-constantan wire. The calibration was made by Diesselhorst's compensation method (reference 14), the most accurate method for the determination of the thermoelectric tension, by comparison with officially calibrated mercury thermometers in water or oil bath (reference 15) before and after the tests.

From equation (1) which with $c_p = 0.241 \text{ kcal/kg } ^\circ\text{C}$ for air can also be written

$$T_{\text{tot}} - T_{\text{stat}} = \frac{w_0^2}{2020} \quad (7)$$

it is seen that an accurately measurable reference temperature is necessary if the accuracy for a temperature recorder is to be possible. This reference temperature is the chamber temperature T_d , which can be equated to the stagnation temperature T_{tot} . $T_d = T_{\text{tot}}$. The error introduced by not measuring the true temperature but rather almost T_{tot} , is negligible. The error is greatest at 310 m/s jet velocity - this corresponds to a 11.9 m/s velocity in the chamber - namely 0.08°C , or less than 0.2 percent of the adiabatic temperature difference. T_{stat} is computed from T_d and w according to equation (7). The temperature T_a is read off and the respective error or accuracy computed with equations (3) and (4), respectively.

For measuring the chamber temperature T_d a thermocouple whose junction has an area of about 1 mm^2 , mounted in the center of the chamber section proved insufficient since the corresponding area in the jet is only $1/26 \text{ mm}^2$, whereas the initial state at least for the central jet of 20 mm diameter must be known. For this reason six thermocouples were disposed on supports in the hexagon over a circle of 156 mm, with a seventh added in the center.

On comparison of these thermocouples, it was found that by too much cooling the highest thermocouple indicated lower than the others. So, in order to explore the effect of the cooling, two more thermocouples were added above and below. The inflow of the cold water above di-

rectly before the chamber (fig. 3) caused a several-tenths degree lower temperature above than in the middle, the divergence increasing with the coldness of the cooling water. The difference was least when the cooling water circulated over the condenser only, i.e., when the circulating water cooled itself. Then the temperature in the median circular section of 156 mm diameter was the same everywhere. The drawback of this cooling is the gradual temperature rise in high speed tests during a test series. However, since only temperature differences and no absolute temperatures were involved, this drawback was of no special significance so long as the rise in the jet and in the chamber was simultaneous. For the subsequent tests four of the seven central thermocouples were disposed one behind the other for the purpose of obtaining the average for any minor temperature fluctuations within the median section.

The continuous change of the reading in the jet despite the constant chamber temperature was disturbing during the first tests. The cause was soon found: The temperature of the cold junction increased. The cold junction was packed in ice in a soapstone tube within a thermos bottle. When the junction was merely inserted in the ice, the melting of the ice made the temperature rise and so caused the wrong measurement. An improved arrangement which made it possible that the melting water drained off from the junction, kept the temperature constant for a long time.

The holding devices to which the instruments for measuring the temperature in the jet were fastened, were screwed to a support, sliding on a rail at right angle to the direction of the support movement. In this manner the junction could always be adjusted to jet center and 40 mm away from the nozzle mouth.

The leads from both test stations passed through the test chamber to the outside, since the vibrations in the test chamber made correct reading impossible. The line resistances were checked with a Wheatstone bridge before and after each test. The thermal force was determined by a reflecting galvanometer with lowest readability of 0.2°C and a mirror instrument which permitted the reading of differences of 0.05°C . Since the four in-line thermocouples were measured by reflecting galvanometer, the accuracy of both temperatures is 0.05°C . All the experiments were effected at subsonic flow velocities.

TEST PROCEDURE AND RESULTS

a) Tests with Immersion Tubes

Since the VDI specifications (reference 16) for temperature measurements in flowing mediums recommend the use of immersion tubes, the first experiments were made with two such tubes (fig. 6), one smooth, the other with several fins at the lower end to increase the heat exchange. These tubes were attached by cover strap to a flange screwed on the nozzle (fig. 7). Copper-constantan thermocouples and mercury thermometers served as recording instruments.

The measurements had to be made at fixed chamber temperature because the temperature reading in the immersion tube lagged, especially on the thermometer. The superiority of the finned version through propitious exchange of heat and little radiation is readily apparent from the results (fig. 8), the accuracy - according to equation (4) - is, on the average, 8 percent higher. The superior indication of the thermometer over the thermocouple is probably due solely to the air cushion existing between the bottom of the immersion tube and the junction while the thermometer rested on the bottom. A supplementary test with lowered immersion tube so that the whole tube was exposed to the jet, resulted in a 2- to 3-percent improvement. These experiments revealed the close relationship existing between the indicating accuracy and the design, position, and immersion depth. This means that every single immersion tube must be calibrated.

b) Design of Body for Stagnation Temperature Recording

In view of the fact that all past attempts to measure the stagnation temperature by stretching thermocouples lengthwise or crosswise to the direction of flow had proved unsuccessful, it seemed logical to locate the junction in the stagnation point of streamline bodies, where the change from kinetic to potential energy is amply assured. The design of an instrument for measuring the stagnation temperature had to meet the three conditions, as follows:

- 1) The junction must be located in the stagnation point.

- 2) Radiation losses must be prevented as much as possible.
- 3) Heat dissipation must be kept at a minimum.

As for 2), it was practically disregarded, while 3) was very closely complied with. The main task consisted in finding an aerodynamically beneficial body design. The first two tests with designs a and b (fig. 9) illustrate the effect of body shape. A piece of steel tubing of 4 millimeters diameter and 0.5 millimeters wall thickness, cut off at the end facing the flow direction, was soldered to a streamline tube; the tube was attached by a stuffing-boxlike packing and a piece of flat iron strip to the support (fig. 10), and supported by steel wires to avoid oscillations. The Cu-Ko junction was situated in the center of the cut, the wires being insulated from the walls and from each other by plaster of paris or porcelain beads. Design b differed from design a by the rounded edges of the cut (fig. 9). The results (fig. 11) indicate plainly the effect of this minor improvement. While the accuracy with design a amounted to 81 percent, it rose to 86 percent, or 5 percent higher for design b.

This success led to two others designs c and d, where particular attention was given to the streamline shape. Design c (fig. 12) consists of a piece of steel tubing of 5 millimeters diameter and 0.75 millimeter wall thickness into which a steatite tube is fitted for a depth of 0.2 millimeter and which carries the Cu-Ko junction. Design d (fig. 13) is a piece of pipe of the same dimensions as c but fitted with a plastic tube carrying a spherical head. The junction is in the vertex point. The exposed wires were rubber insulated against heat and electricity. The method of mounting is shown in figure 14.

The tests, made at a speed of around 280 meters per second, showed an average accuracy of 94 percent for design c and 92 percent for design d (fig. 11), or a substantial improvement over design b. The reason for the greater accuracy of c cannot be explained from the findings up to the present. It was observed that at higher speeds the indicating accuracy rises a little but falls off considerably at the lower speeds. This phenomenon will be discussed in detail later.

Of the designs so far, c shows the greatest accuracy with 94 percent, although at a very arbitrary disposition

of the junction at 2 millimeters from the edge. The next problem was to ascertain the effect of this location of the junction on the reading. For this study design e (fig. 15) was developed. It closely resembled design c, but it had an insulating body of plastics instead of steatite and was threaded so that the distance: body end - junction (= distance a = depth of thread) could be varied. Various settings of insulating body and hence of the junction were explored: at the end ($a = 0$), at distance $a = 1.0$, $a = 2.0$, and $a = 4.0$ millimeters. Figure 16 shows the resulting indicating errors plotted against the stagnation temperature for different settings a , and figure 17 the percentage of accuracy against a at different speeds. The best values are those obtained for $a = 0$; insertion of the junction on the inside is detrimental to the readings because of the creation of a dead zone without access to fresh air and new heat energy.

These experiments definitely show that the accuracy is much inferior at low speeds, explained by the fact that the boundary layer becomes thinner at high speed (the boundary layer thickness is, accordingly to Prandtl (reference 17), inversely proportional to the root of the Reynolds number), as a result of which at low speeds the thicker boundary layer renders the transformation into potential energy difficult. This phenomenon is not mathematically solvable; it depends on the body shape and the surface condition. The error curves plotted against the speed in figure 16 therefore do not follow a parabola conformable to equation (7) but deflect at high speed.

The greatest accuracy at 2 millimeters distance corresponding to design c is only about 90 percent as against 94 percent for c, in spite of the identical arrangement. The plastic insulation cannot possibly induce this inferiority of indication. The only existent difference is that on design e the junction sits firmly on the plastic while on c the junction protrudes a little because of the brittleness of steatite. In the next tests the junction was pulled out of the insulating body: at settings $a = 1$ mm (figs. 18 and 19) and $a = 0$ mm (figs 20 and 21). The results, plotted against speed and distance of insulation body and junction (= b), indicate that by these measures the greatest accuracy at 275 meters per second speed rises above 95 percent. The best settings are at $a = 1$ mm, $b = 2$ mm, and $a = 0$ mm, $b = 1$ mm. In both test series the indication is therefore best when the junction protrudes 1 millimeter. This explains the better behavior of design c over design d.

The causes of this phenomenon are explained on a sphere of 10 millimeters diameter (fig. 22). The experiments with this design, f (figs. 23 and 24), which also carried an insulation of plastics, yielded an even greater accuracy up to 97.5 percent at 275 meters per second speed and $b = 2$ mm junction distance but only 93.5 percent in the stagnation point ($b = 0$) at the same speed. In the stagnation point where the speed is zero, hence no fresh air enters, heat is carried off only, no new compressed and therefore heated air enters. Conditions must become more favorable when the air strikes past the junction at low speed, that is, as in the position to give off new heat energy on the junction. This is achieved when the junction, rather than in the stagnation point itself, is placed a little ahead of it in a region of still low speed. If the junction then sticks out too far it comes in a range of unduly high speed and the accuracy suffers. The higher radiation losses caused by pulling the wires forward is insignificant compared with the gain in enhanced heat change. The error consequent to this measure is, relative to the stagnation temperature, only $2\frac{1}{2}$ percent at maximum speed, as against $5\frac{1}{2}$ percent at 150 meters per second speed. However, this higher percentage of error at low speed is not decisive as the absolute error on the basis of the test conditions is 0.95° C at 275 meters per second, but only 0.6° C at 150 meters per second, relative to the stagnation temperature.

To illustrate these processes the flow distribution of a frictionless fluid around a sphere with potential lines and lines of equal velocities is given in figure 25. The velocity in flow direction (x direction) follows the differentiation of the potential function as

$$\Phi = a x \left[1 + \frac{1}{2} \left(\frac{R}{\sqrt{x^2 + y^2 + z^2}} \right)^3 \right]$$

along direction x at

$$u = \frac{\partial \Phi}{\partial x} = a + a R^3 \left[\frac{1}{2} \frac{1}{(\sqrt{x^2 + y^2 + z^2})^3} - \frac{3}{2} \frac{x^2}{(\sqrt{x^2 + y^2 + z^2})^5} \right]$$

whereby $a = w_\infty$, the velocity in undisturbed flow and R the radius of the sphere, or in polar coordinates at

$$\Phi = a \left(r + \frac{R^3}{2r^2} \right) \cos \varphi$$

and

$$u = a + \left(\frac{R}{r}\right)^3 \frac{a - 3a \cos^2 \phi}{2}$$

The best setting of the junction, which was also recorded, is $\frac{R}{r} = 0.72$ for the 10-millimeter sphere if r is the

distance: junction - center of sphere; at that point the theoretical velocity in x direction is 63 percent of that of the undisturbed flow. It should be noted in this representation that actually no exact potential flow exists, when the velocity distribution departs somewhat from that shown here. Besides, the junction itself disturbs the flow. If it is assumed at first that the indicating accuracy was

dependent upon the ratio $\frac{R}{r}$, i.e., that always independent

from the shape of the experimental body, the best indication is achieved when the theoretical velocity at the junction amounts to 63 percent of that of the undisturbed flow, and this assumption was checked on a sphere of 20 millimeters diameter (fig. 26). The greatest accuracy should, accordingly, be achieved at a distance $b = 4$ millimeters, but the test (figs. 27, 28, and 29) disclose the best indication at $b = 2.5$ millimeters, that is, for $R/r = 0.80$ and a speed at the junction of only 50 percent of w . This is indicative of yet other influential factors (such as size of junction, thickness of wire).

The question of whether the same results could be achieved with other streamline bodies was settled in tests with a static pressure plate of 10 millimeters diameter (fig. 30) as used for the dynamic pressure measurement. The junction was again placed at different distances from the surface of the body and the effect of this measure investigated. The accuracy obtained is shown in figures 31 and 32 plotted against speed and distance b . The maximum with 97 percent lies at $b = 2.5$ millimeters, or almost as high as for design f . The changed distance is explained by the divergent course of the streamlines.

The method of mounting the test bodies by screwing into a holder clamped on both sides is unsuitable for practical measurements, as in steam turbine tests, for instance, it leads to installation difficulties and in pipe-line experiments the flow is appreciably disturbed. It is much easier to introduce the test sphere from the outside wall if the sphere is fitted with a strut as shown in figures 33 and 34, although it has the drawback of destroying the

flow symmetry, which is disturbed by the strut on one side. The two spheres i and k of 10 and 20 millimeters diameters (figs. 33 and 34), respectively, were intended to elucidate the effect of the strut of 5 millimeters diameter.

The sphere was screwed in a holder pivoted on the stirrup of the support (fig. 35), in addition to which an angle holds the holder solidly to the flange. The considerably smaller area of disturbance in the jet following this new arrangement boosted the maximum from 280 to 310 meters per second. The experiments (figs. 36, 37, 38, and 39) yielded the maximum at the same distances b as with designs f and g; the indicating maximum with design i is 95 percent, with design k, 97 percent. The inferior result with the smaller i can only be attributed to the strut effect. The strut should therefore be as small as possible in relation to the sphere diameter.

The safeguards taken so far - heat insulation, junction in stagnation point of streamline body, supply of fresh air to junction - produced a stagnation temperature reading to within 3 percent residuary error from the adiabatic temperature gradient. Further designs embodying aerodynamic improvements promising improved flow but no increased stagnation effect should produce no appreciable increase in accuracy. The residuary losses are attributable to heat dissipation, heat transfer, and radiation. Since the radiation losses can be considered as being very small, a reduction in heat-dissipation and heat-transfer losses by the use of a metal of less conductivity than copper was indicated. But this metal should have the same high thermal force as copper. The choice fell to iron-constantan with a thermal force of around $0.05 \text{ mV}/1^\circ \text{ C}$ as against $0.04 \text{ mV}/1^\circ \text{ C}$ for Cu - Ko. The conductivity of iron is but a tenth of that of copper. The tests with an iron-constantan junction in design k (figs. 40 and 41) disclosed an error of 1 percent at 300 meters per second and of 2 percent at 150 meters per second. Compared to most favorable error of one degree before, it is now only 0.4° . The 0.6° was, in consequence, heat dissipation and heat transfer loss; now, λ_{Fe} being a tenth of λ_{Cu} , it amounts to about 0.06° C , i.e., around 0.2 percent. An added advantage is the minor dependence of the accuracy on the Reynolds number.

The drawback of design k is its size for many practical measurements; so a smaller design l was developed. (fig. 42). It is similar to i but the strut has a diam-

eter of only 2.5 millimeters. A 1.25-millimeter diameter was impractical for constructive as well as for strength reasons. Even with the 2.5-millimeter strut the insulating difficulties were considerable, a coating of lacquer as well as a layer of oil-impregnated paper resulted in a short circuit or grounding, and it required the insertion of a plastic cylinder of 1.8 millimeters diameter and two holes of 0.6 millimeter diameter each in the hollow strut to achieve perfect insulation. The findings with Fe-Ko thermocouples (figs. 43 and 44) resemble those obtained with design i, but with a much better indicating maximum of $98\frac{1}{2}$ percent at $b = 1.8$ millimeters, or almost as good as with design k. Its drawback compared with k is that the maximum with l is reached at only one setting of the junction ($b = 1.8$ mm) whereas with design k the indicating accuracy is almost constant throughout the range from $b = 2.0$ to $b = 3.0$ millimeters (fig. 41). For exact measurements in larger sections the use of design k with Fe-Ko thermocouple is therefore recommended.

The design satisfies the condition for maximum accuracy in stagnation temperature recording. Reproduction being easy, it is not necessary to calibrate every single instrument. The still existing error of from 1 to 2 percent relative to the adiabatic temperature gradient can in most cases be disregarded in practical measurements.

c) Effect of Flow Direction on Stagnation Temperature Reading

For acceptable measurements even with flow direction not accurately known, the developed designs must be very insensitive to changes in flow direction. This directional susceptibility was explored with the spherical instruments. The results with i, k (Cu-Ko junction), k (Fe-Ko junction), and l are shown in figures 45 to 48. The speed and the location of the junction b at which the tests were made are also shown. The ordinate gives the indicating accuracy according to equation (4) in percent, rather than the temperature differences. Up to an angle of around 15° to the flow direction the indication remains unchanged. The indicating accuracy becomes substantially worse up to 90° . Beyond that a new marked drop occurs as the junction has then entered the region of breakaway phenomena. Inclined at 180° in flow direction, the accuracy has decreased to 65 to 72 percent.

The most interesting region between $+45^\circ$ and -45° is illustrated in figure 49 for k (Fe-Ko junction) and l, with

the inclination of the temperature difference plotted against the reading at 0° . The maximum value with k is indicated up to 17° , with l up to 11° , at 30° the divergence with k is 1.1 percent, with l , 3.6 percent. So with respect to nondirectional susceptibility the sphere of 20 millimeters diameter is also superior to one of only 10 millimeters diameter.

d) The Laws of Similarity in Temperature Recording
of Flow Gas

Assume a temperature-recording instrument having approximately the shape of design i , k , or l , in a gas flow at speed w_0 and true temperature $T_w = T_{stat}$, as sketched in figure 50. The spherical bead has the diameter D . Compression of the gas produces at the junction the temperature T_a . By adiabatic expansion the stagnation-point temperature T_{tot} would have occurred here. The difference between T_{tot} and T_a is caused by the continual removal of heat toward the outside. Part of the evacuated heat passes through the instrument itself on its way to the outside. This heat volume Q_m is proportional to the temperature difference $T_a - T_{wall}$, and to the surface of the instrument and consequently to the square of the diameter. The path of the heat on its outward flow is proportional to the diameter D . Therefore the outflowing heat volume is inversely proportional to the diameter, because the resistance increases with the path. Thus the heat volume evacuated through the instrument may be expressed as follows:

$$Q_m = k_1 (T_a - T_{wall}) D^2 \frac{1}{D} = k_1 (T_a - T_{wall}) D$$

Another part of the heat passes off along with the gas itself. This part of the heat is proportional to the same temperature difference as above and likewise proportional to the surface, i.e., D^2 , besides being also inversely proportional to the traveled path, i.e., proportional to quantity $\frac{1}{D}$. Furthermore, this heat volume is, of course, proportional to the heat conductivity factor. Hence,

$$Q_g = k_2 (T_a - T_{wall}) D \lambda$$

A third part of the heat volume is lost by radiation. This part is proportional to the radiant surface, i.e., D^2 , the difference of the fourth power of T_a and T_{wall} and proportional to the radiation factor C , hence

$$Q_{rad} = k_3 D^2 \left[\left(\frac{T_a}{100} \right)^4 - \left(\frac{T_{wall}}{100} \right)^4 \right] C$$

The total heat removal calls for an identical amount of heat input. This input is proportional to the flow section, i.e., D^2 , proportional to speed w_0 , and proportional to the temperature difference between the temperature T_{tot} produced without heat exchange and the junction temperature T_a . The heat input is, furthermore, proportional to the specific heat C_p for 1 cubic meter of gas at constant pressure. Hence,

$$Q_{input} = k_4 D^2 w_0 (T_{tot} - T_a) C_p$$

Combining now the requirements which must be met if the same indicating accuracy is to prevail in a different temperature measurement, we find that in both cases the ratio $(T_a - T_{wall}) : (T_{tot} - T_{wall})$ must equal constant.

First requirement: Geometric similitary in the outside shape of the test instrument and flow channel. This requirement includes, for instance, the same ratio $\frac{b}{D}$, $\frac{d}{D}$, and $\frac{l}{D}$, as well.

Second requirement: The ratio of the unit volume of flowing gas in the undisturbed flow and in the stagnation point must in both cases be the same:

$$\frac{v_0}{v_{stag}} = \text{const}$$

Third requirement: To insure geometric similarity of streamline patterns in both cases, the Reynolds number in both pressures must be the same:

$$R = \frac{w_0 D}{\nu} = \text{const}$$

Fourth requirement: In both cases the four quoted

heat volumes, namely, Q_m , Q_g , Q_{rad} , and Q_{input} must be in the same ratio among themselves if the temperature fields are to be similar. This last requirement resolves itself into three separate requirements:

Requirement 4a:

$$Q_m = k_6 Q_{input}, \quad T_{tot} - T_a = k_5(T_a - T_{wall})$$

$$k_1(T_a - T_{wall})D = k_6 k_4 D^2 w_0 k_5 (T_a - T_{wall}) C_p$$

whence

$$\frac{D w_0 C_p}{k_1} = \text{const}$$

k_1 is the heat removed from a geometrically similar test instrument with $D = 1$ meter and at $T_a - T_w = 1^\circ \text{C}$.

Requirement 4b:

$$Q_g = k_7 Q_{input}$$

hence

$$k_2(T_a - T_{wall})D\lambda = k_7 k_4 D^2 w_0 k_5 (T_a - T_{wall}) C_p$$

whence

$$\frac{D w_0 C_p}{\lambda} = \text{const} \quad (\text{reference 18})$$

Requirement 4c:

$$Q_{rad} = k_8 Q_{input}$$

whence

$$k_3 D^2 \left[\left(\frac{T_a}{100} \right)^4 - \left(\frac{T_{wall}}{100} \right)^4 \right] C = k_8 k_4 D^2 w_0 k_5 (T_a - T_{wall}) C_p$$

consequently:

$$\frac{(T_a^4 - T_{wall}^4) C}{(T_a - T_{wall}) w_0 C_p} = \text{const}$$

The cited requirements can be satisfied only if both

flows are completely identical. In all other cases only part of the requirements can be met. It is therefore necessary to ascertain what requirements are most important. Radiation, forming only a minor fraction of the total heat removal (requirement 4c), can be dropped.

It is impossible to say, from the very first, whether the heat removed by the gas or the instrument is greater; hence these two must remain. Requirement 4b by itself is known (Grashoff's characteristic); 4a represents a condition for the dimensions and the heat conductivity of the instrument. It is manifest that with increasing dimensions (D increases) by otherwise unchanged physical values ($w_0, C_p = \text{const}$) the heat removed by the instrument decreases in ratio to the heat input. For the heat input grows with D^2 , but the heat removal only with D . The indicating accuracy of the larger instrument must therefore be greater, as confirmed, in fact, by the results of the tests, whereby it is to be noted, of course, that the wires in the instrument had the same diameter in both cases. In this instance the heat resistance is increased from the start by the increasing wire length. This means that the constant k_1 on the large instrument is lower than on the small one. This fact also affords improved indicating accuracy.

Constants k_2 to k_3 are the same in both cases so long as the dimensions and the temperature fields are geometrically similar. Constant k_1 may be termed the heat conductivity factor of the instrument. Constant k_2 depends upon the Reynolds number and the volume ratio at compression in the stagnation point. The dependence on the Reynolds number follows from the boundary layer thickness through which the heat transfer is affected. In what manner the volume ratio on k_2 makes itself felt, is difficult to say.

We can write, in general,

$$k_2 = f \left(R_0, \frac{v_0}{v_{\text{stag}}} \right)$$

The heat balance reads:

$$Q_m + Q_g + Q_{\text{rad}} = Q_{\text{input}}$$

$$k_1 (T_a - T_{wall}) D + k_2 \lambda (T_a - T_{wall}) D + k_3 D^2 \left[\left(\frac{T_a}{100} \right)^4 - \left(\frac{T_{wall}}{100} \right)^4 \right] C$$

$$= k_4 D^2 w_o (T_{tot} - T_a) C_p$$

or

$$\frac{k_1 + k_2 \lambda}{k_4} (T_a - T_{wall}) + \frac{k_3}{k_4} \left[\left(\frac{T_a}{100} \right)^4 - \left(\frac{T_{wall}}{100} \right)^4 \right] C =$$

$$= D w_o (T_{tot} - T_a) C_p$$

In its first form this equation is homogeneous with four variables k_1, k_2, k_3, k_4 . (Division by k_4 reduces the variables to three. The variables k_1 and k_2 are again combined to one term, expressed with k_9 :

$$k_1 + k_2 \lambda = k_9$$

This reduces the equation to two variables. These variables can be computed by inserting two test values measured with an instrument. For in the heat balance equation all the other quantities are to be presumed as known. The practical result of this calculation is a numerical prediction of the radiation effect. If the second term of the transformed heat balance equation is very small compared to the first, it means that the radiation effect is small. Then the radiation can be simply disregarded in a further approximate analysis.

Suppose $k_1 = \text{const.}$ Then quantity k_2/k_4 can be computed as a function of the Reynolds number with, of course, one unknown additive constant. It is to be assumed that k_2 increases with the Reynolds number. It is advisable, however, to plot at the same time the volume ratio against the Reynolds number, since k_1 itself is dependent upon it.

Then two corresponding measurements with different diameter can be compared, that is, either

- a) at the same Reynolds number, or
- b) at the same speed w_o or volume ratio.

If we assume that k_2 in case a) or case b) is constant, the change in k_1 due to changed instrument diameter can be computed.

e) Experiments with a Plate Thermometer

According to a theoretical deduction by Pohlhausen (reference 12), in laminar flow the temperature indicating error relative to the true temperature of the flowing medium can be computed solely dependent on the material characteristics of the medium. After the indicating temperature of a plate thermometer, Pohlhausen's correction is applied:

$$T_{\text{stat}} = T_{\text{ind}} - \frac{1}{4} (T_{\text{tot}} - T_{\text{stat}}) \beta (\sigma)$$

or (equation (1)):

$$T_{\text{stat}} = T_{\text{ind}} - \frac{A}{4} \frac{w^2}{2gc_p} \beta (\sigma)$$

where $\beta(\sigma)$ depends on the material constant $\sigma = \frac{\eta gc_p}{\lambda}$

The question then arose whether this equation was equally applicable to turbulent flow. The experiments were carried out over a temperature range of from 0° to 40° C, where

$$\eta_{0^\circ} = 1.71 \times 10^{-6}, \quad \eta_{40^\circ} = 1.95 \times 10^{-6} \text{ kg sec/m}^2,$$

$$c_p = 0.242 \text{ kcal/kg } ^\circ\text{C}$$

$$\lambda_{0^\circ} = 5.64 \times 10^{-6}, \quad \lambda_{40^\circ} = 6.34 \times 10^{-6} \text{ kcal/msec } ^\circ\text{C}$$

whence

$$\sigma_{0^\circ} = 0.720, \quad \sigma_{40^\circ} = 0.731$$

$$\beta(\sigma)_{0^\circ} = 3.40 \quad \beta(\sigma)_{40^\circ} = 3.42$$

Hence $\frac{1}{4} \beta(\sigma)$ is practically constant = 0.85 throughout the explored temperature range. The theoretical indicating accuracy is accordingly 85 percent.

The thermometer (fig. 51) consisted of a thin, round disk 40 millimeters in diameter, carried on a strut 5 millimeters in diameter mounted in the same manner (fig. 52) as designs i, k, and l. According to the results the plate thermometer, while giving the theoretical amount as to order of magnitude, is much dependent for its accuracy on the Reynolds number and therefore is impractical for accurate measurements. This is substantiated by the result of the test series made at 5° inclination. At the maximum speed of 310 meters per second the divergence from the stagnation temperature is 6° C for zero inclination and 9° C for 5° inclination, or a difference of 50 percent referred to zero setting.

Translation by J. Vanier,
National Advisory Committee
for Aeronautics.

REFERENCES

1. Stodola, A.: Z.VDI 47 (1903), p. 1787.
2. Batho: Min. Proc. Instn. Civ. Engrs. 174 (1908), p. 317.
3. Nusselt, W.: Z. ges. Turbinenwes. 13 (1916), p. 172.
4. Müller, Fr.: Z. ges. Turbinenwes. 17 (1920), p. 61.
5. Brun und Vernotte: C. R. Acad. Sci., Paris, 194 (1932), p. 594.
6. Guchmann, Iljuchin, Tarassowa, und Warschawski: Tech. Physics of the USSR. 1935, Heft 5.
7. Jung, Ingvar: Wärmeübergang und reibungswiderstand bei gasströmung in rohren bei hohen geschwindigkeiten. Forsch. auf dem Gebiete des Ingenieurwesens, ed. B, vol. 7, Sept.-Oct., 1936.
8. Meissner, Walther: Temperaturmessung in rasch strömenden gasen. Forschung, Sept./Oct. 1938, vol. 9, no. 5, pp. 213-18.
9. Knoblauch und Hencky: Anleitung zu genauen technischen Temperaturmessungen. München, 1928.
10. von der Nüll, Werner, und Garve, Alexander: Leistung und Wirkungsgrad bei Flugmotorenladern. Jahrbuch 1937 der deutschen Luftfahrtforschung, pp. II 156-61.
11. Schmidt, E.: Z.VDI 82 (1938), p. 401.
12. Pohlhausen, E.: Z.a.M.M. 1 (1921), p. 115.
13. Prandtl, L.: Attaining a Steady Air Stream in Wind Tunnels. T.M. No. 726, NACA, 1933.
14. Diesselhorst, H.: Verh. dtsh. phys. Ges. 4 (1923), p. 23.
15. VDI-Temperaturmassregeln, Bildblatt 5, Bild 38.
16. VDI-Temperaturmassregeln, Bildblatt 3, Bild 17 and 18.
17. Prandtl, L.: Handbuch der Experimentalphysik, vol. IV, pt. 1, pp. 1-41 (1931).
18. Hütte, Bd. I, 26., Aufl., p. 497.

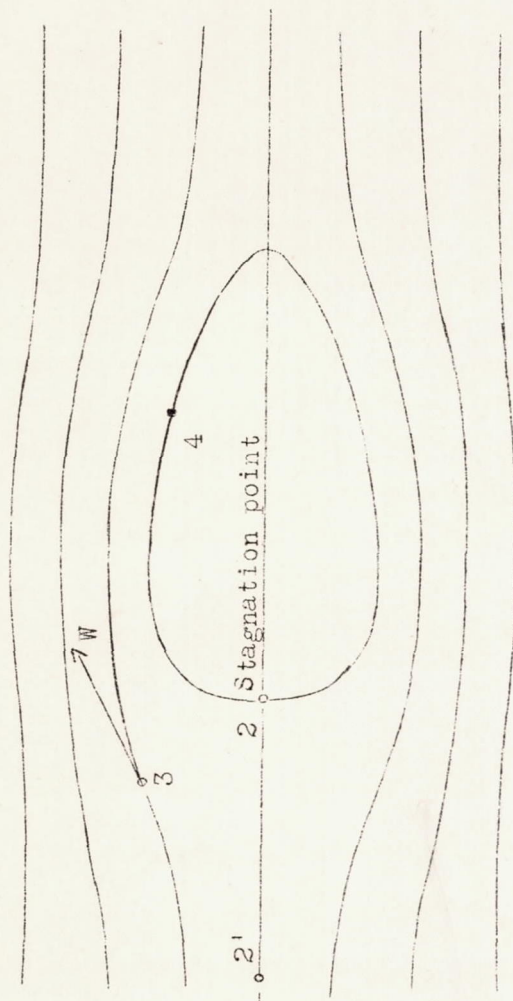

Figure 1. Temperature of flow around a body

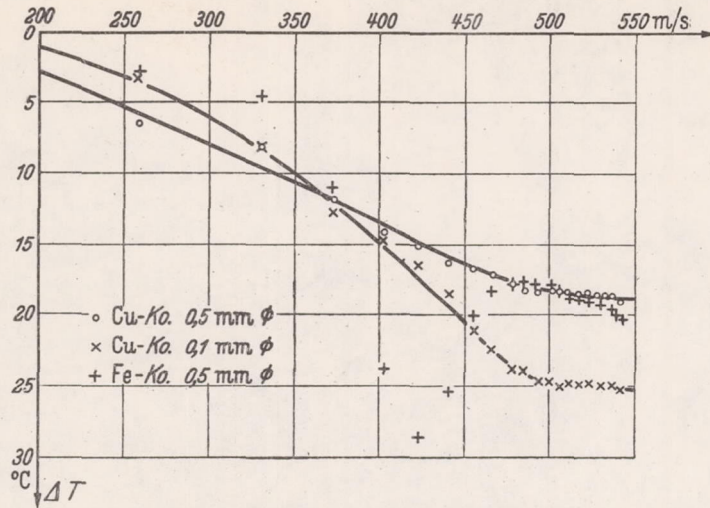

Figure 2.-Nusselt's experiments.

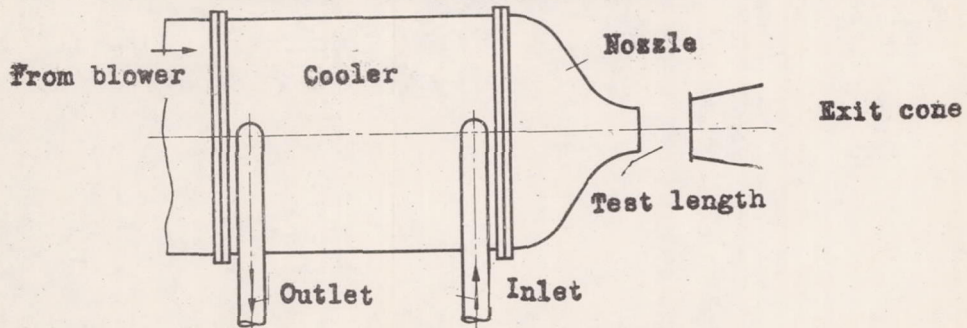

Figure 3.-Experimental setup.

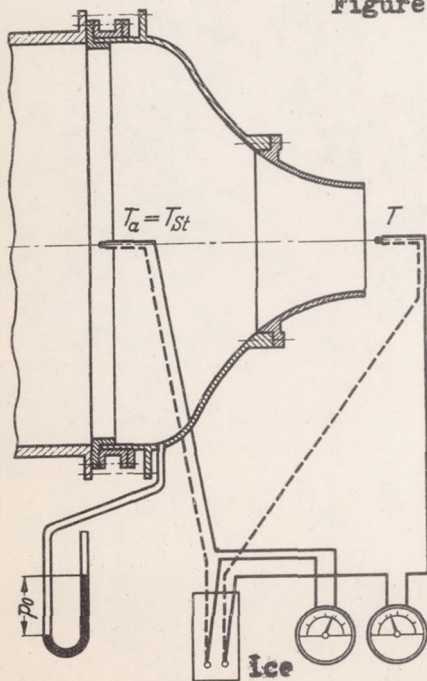

Figure 4.-Test stations.

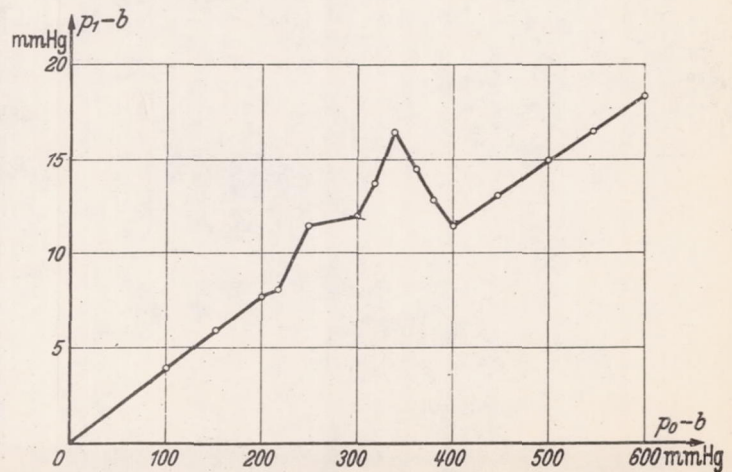

Figure 5.-Static pressure in jet.

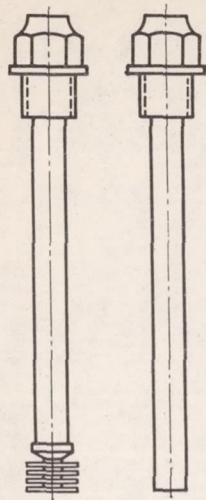

Figure 6.- Immersion tubes; plain and finned.

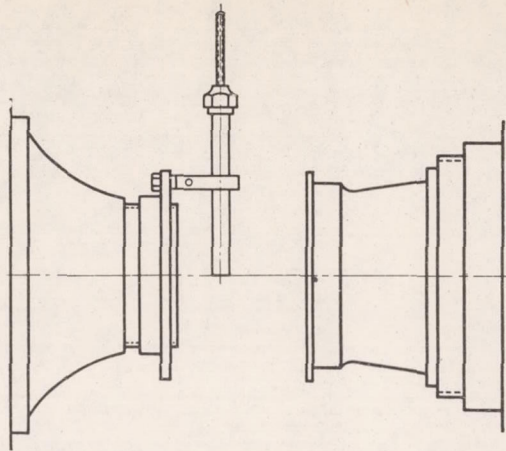

Figure 7.-Mounting of immersion tube.

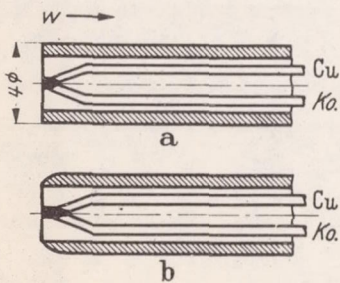

Figure 9.- Design a and b.

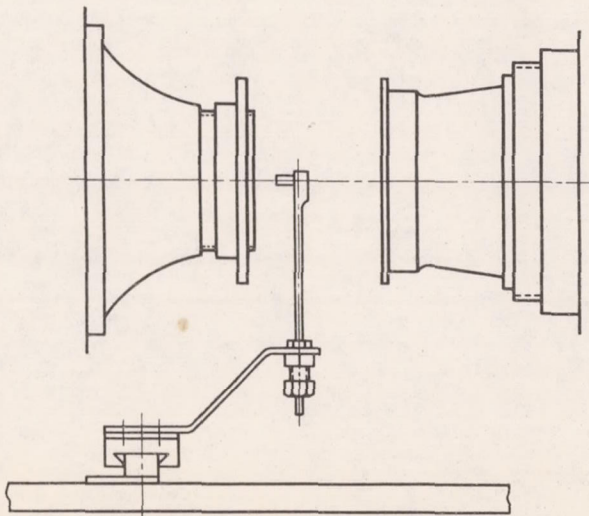

Figure 10.-Method of mounting, a and b.

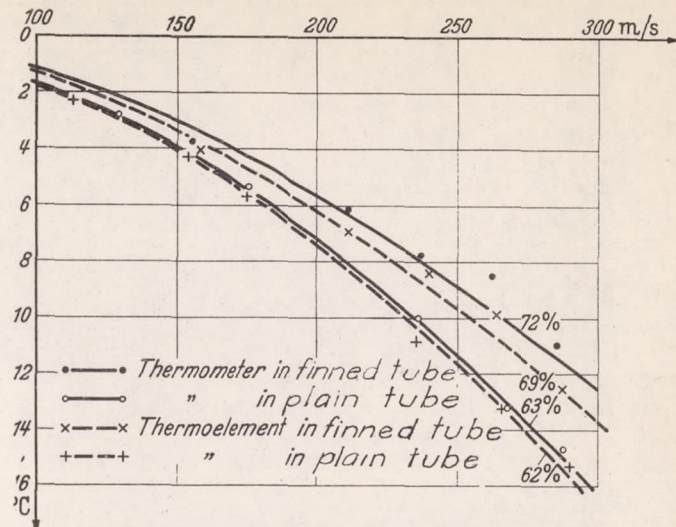

Figure 8.-Test data with immersion tube.

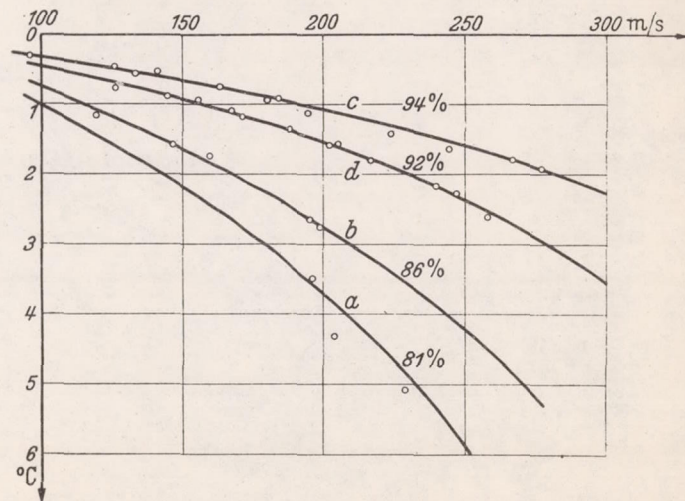

Figure 11.-Test data for a, b, c, and d.

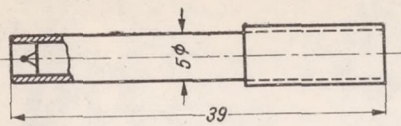

Figure 12.-Design a.

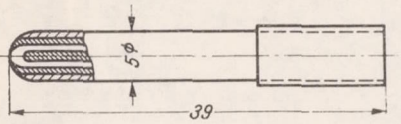

Figure 13.-Design d.

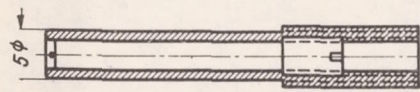

Figure 15.- Design e.

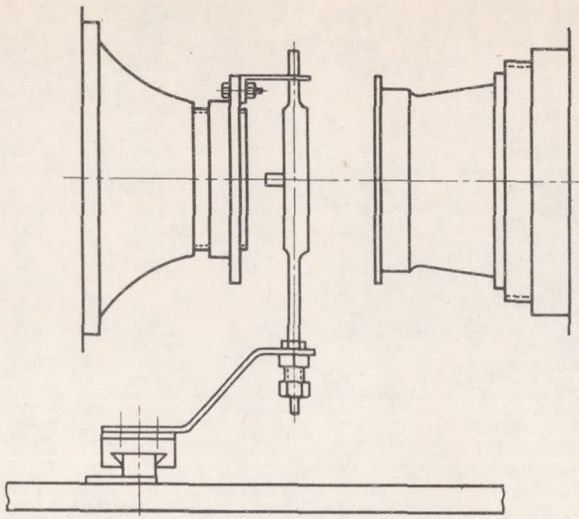

Figure 14.- Method of mounting c,d,e,f,g, and h.

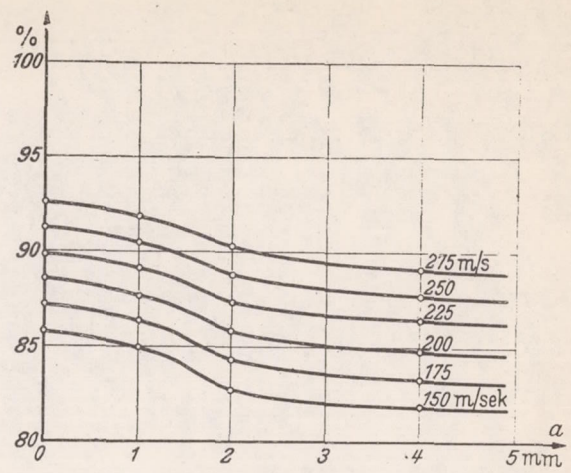

Figure 17.- Results with e at different depth *a*.

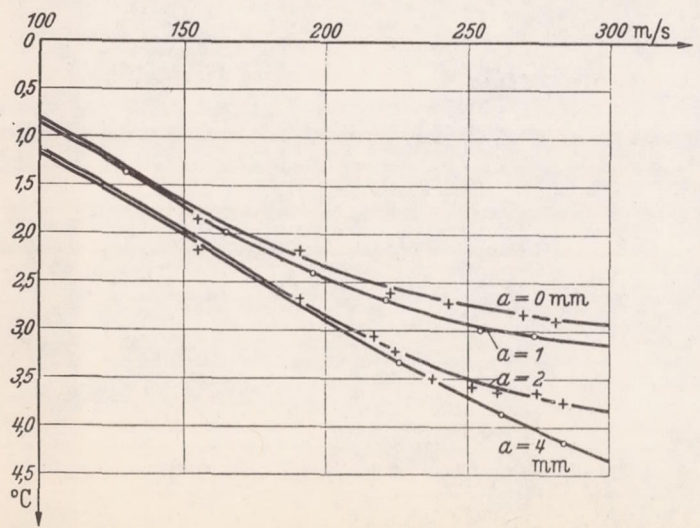

Figure 16.- Results with e at different depth *a*.

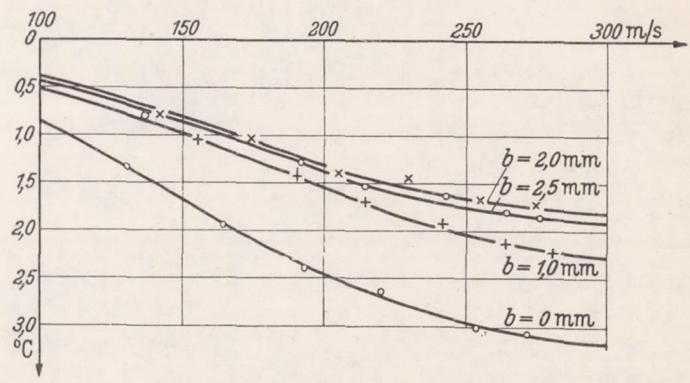

Figure 18.- Results with e at *a*=1 mm and different location of junction

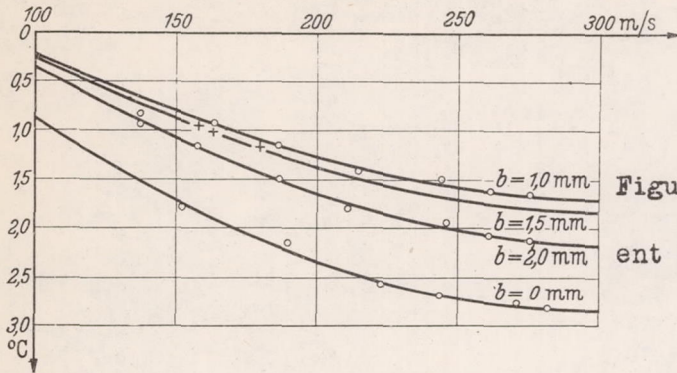

Figure 20.- Results with e at $a=0$ mm and different location of junction.

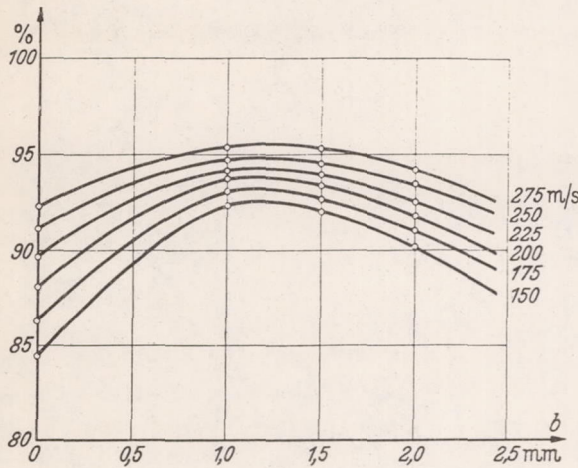

Figure 21.- Results with e at $a=0$ mm and different location of junction.

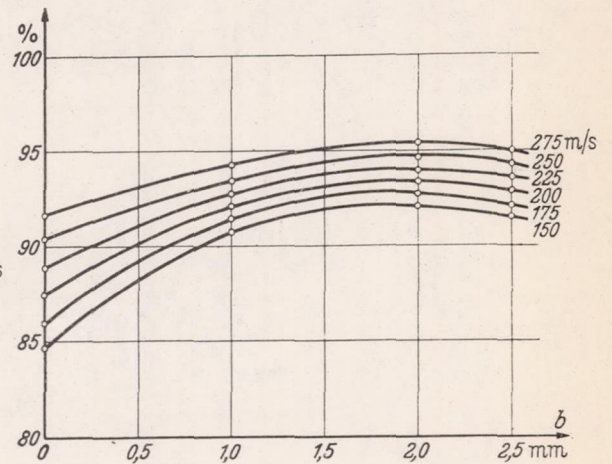

Figure 19.- Results with e at $a=1$ mm and different location of junction.

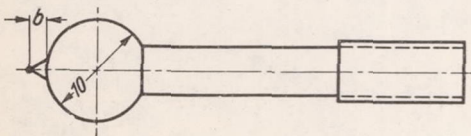

Figure 22.- Design f.

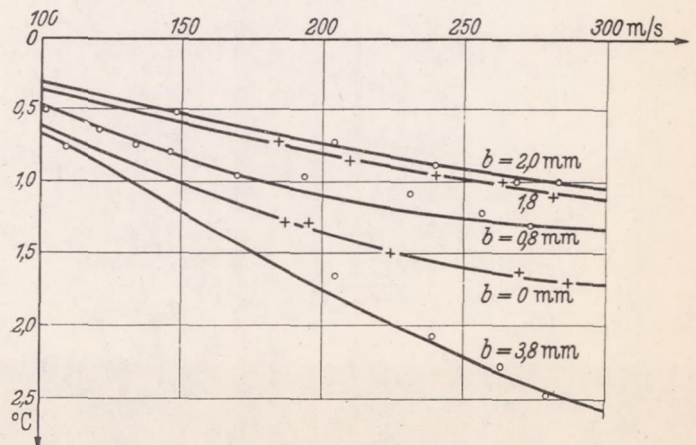

Figure 23.- Results obtained with f.

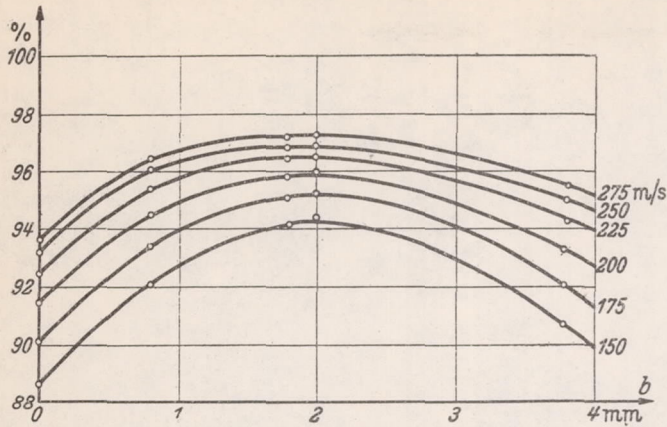

Figure 24.-Results obtained with f.

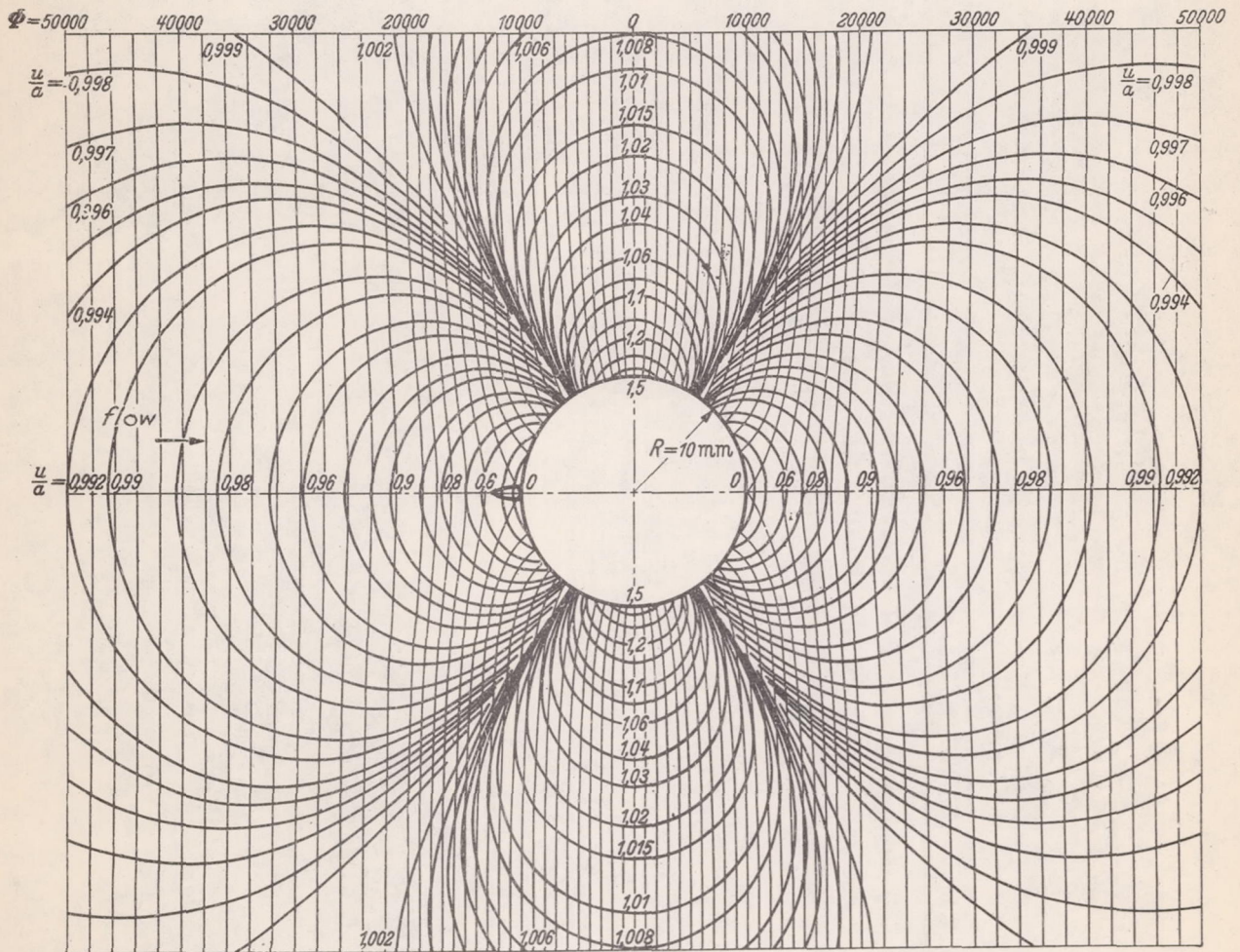
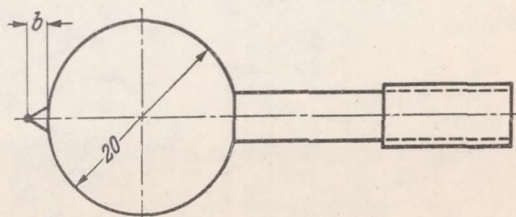

Figure 25.-Flow around a sphere.

Figure 26.- Design g.



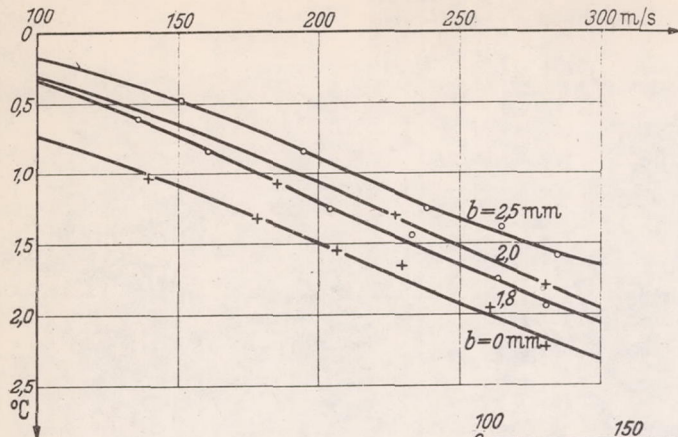

Figure 27.- Results obtained with g.

Figure 28.- Results obtained with g.

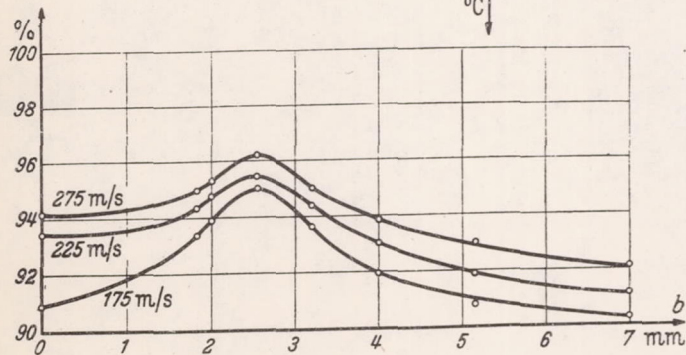
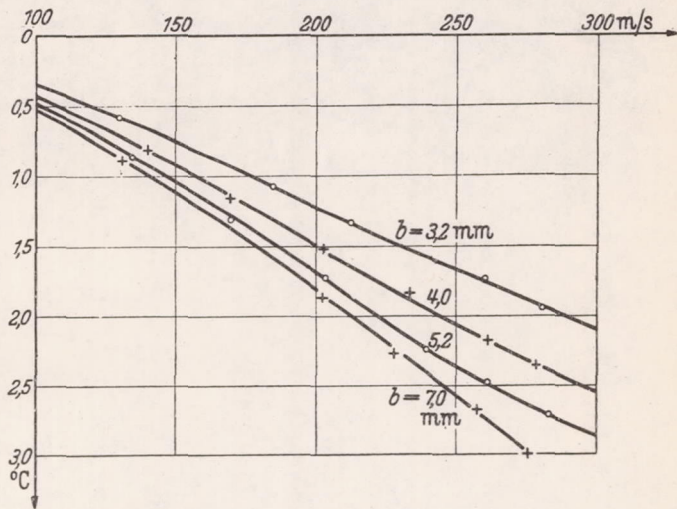

Figure 29.- Results obtained with g.

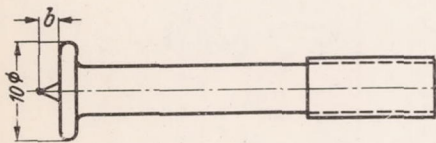

Figure 30.- Design h.

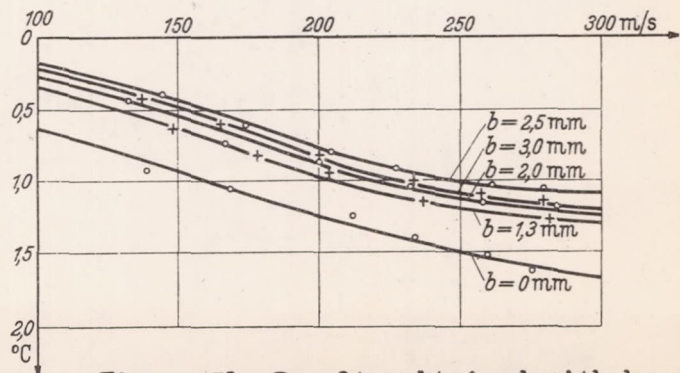

Figure 31.- Results obtained with h.

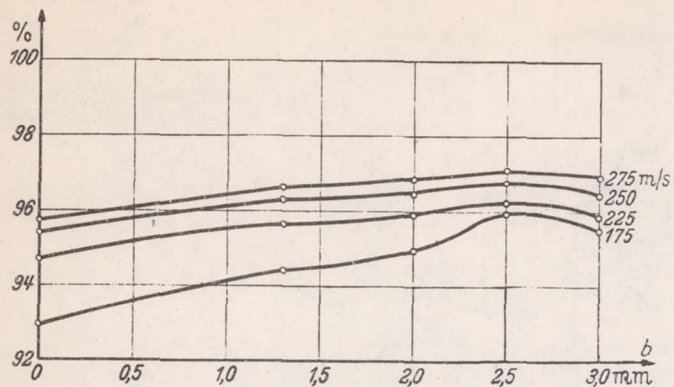

Figure 32.- Results obtained with h.

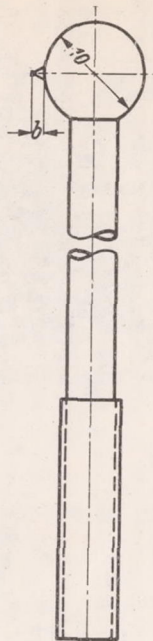

Figure 33.- Design i.

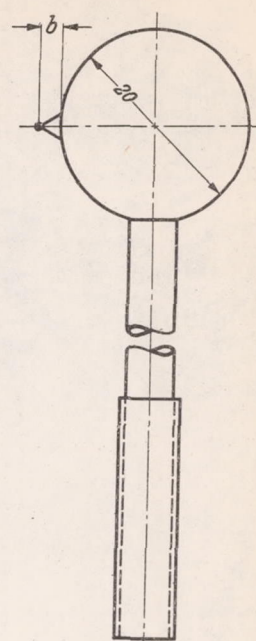

Figure 34.- Design k.

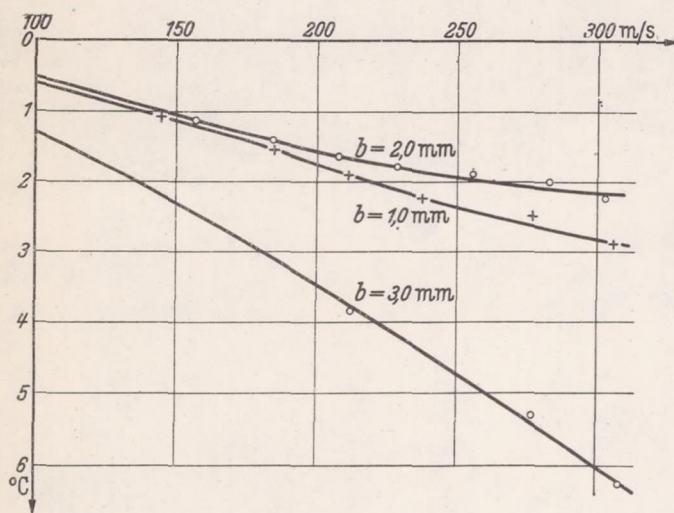

Figure 36.- Results obtained with i.

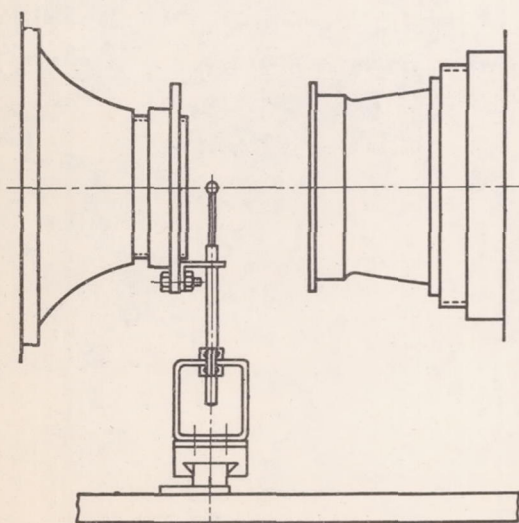

Figure 35.- Method of mounting i, k, and l.

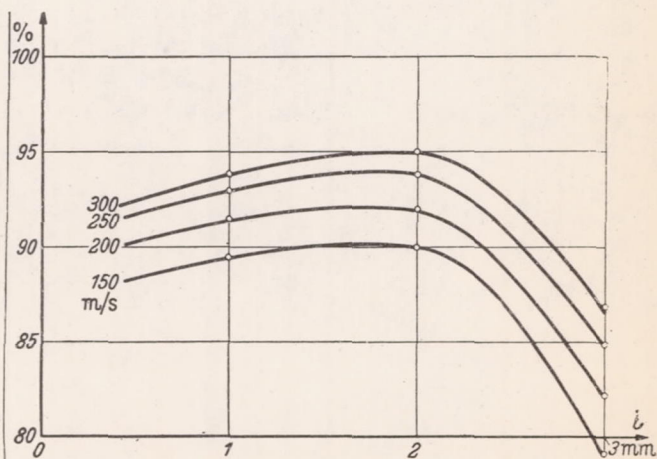

Figure 37.- Results obtained with i.

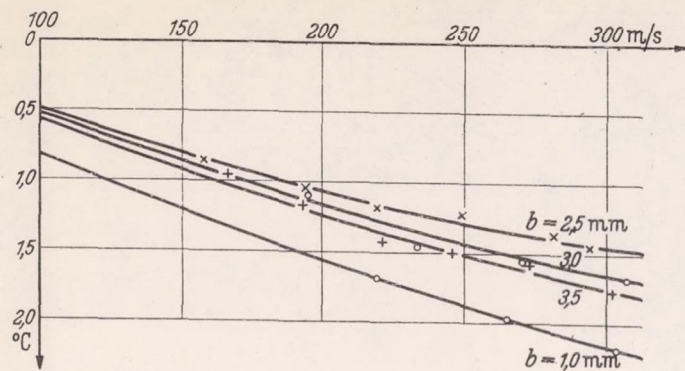

Figure 38.- Results obtained with k (Cu--Ko).

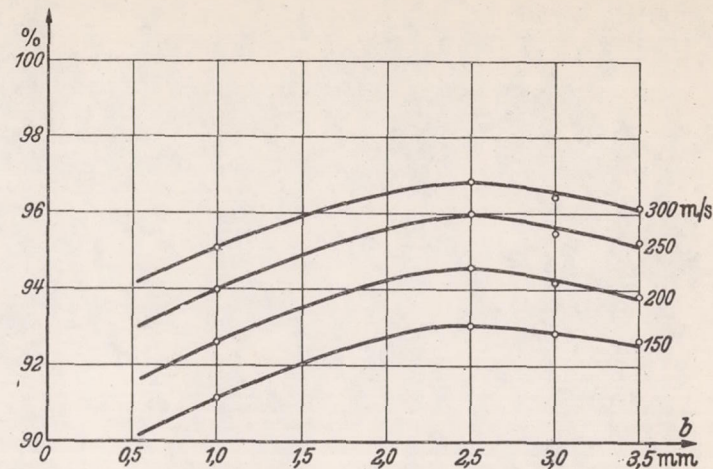

Figure 39.- Results obtained with k (Cu--Ko).

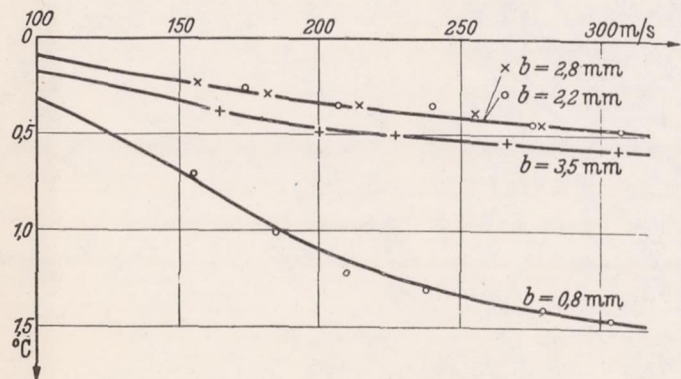

Figure 40.- Results obtained with k (Fe--Ko).

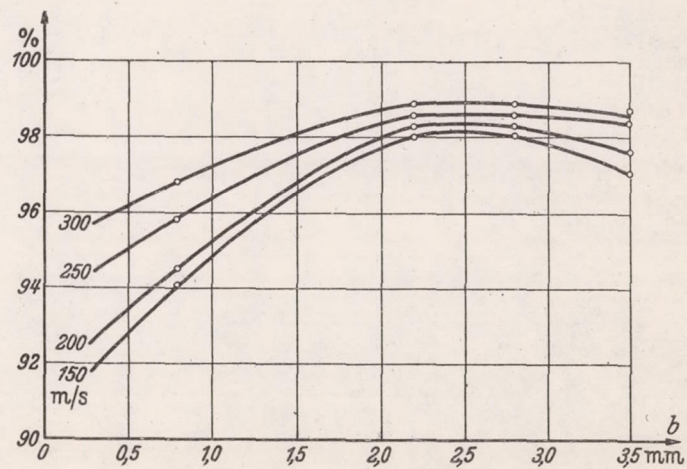

Figure 41.- Results obtained with k (Fe--Ko).

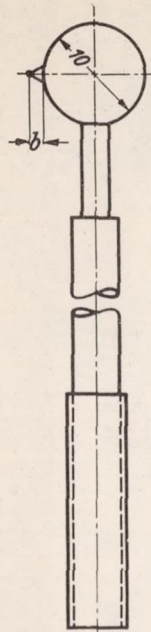

Figure 42.-
Design 1.

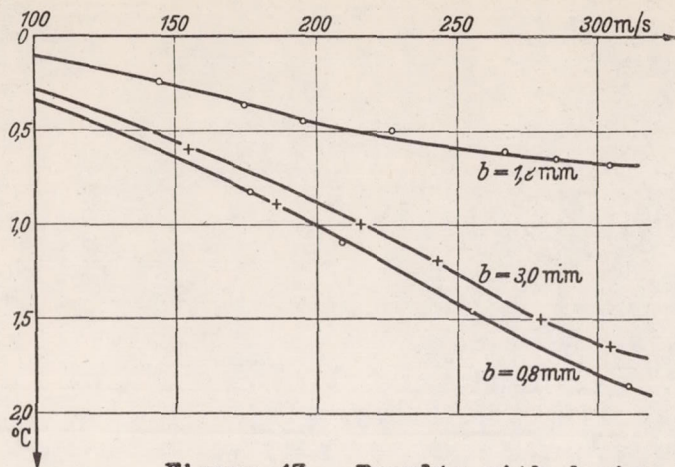

Figure 43.- Results with design 1.

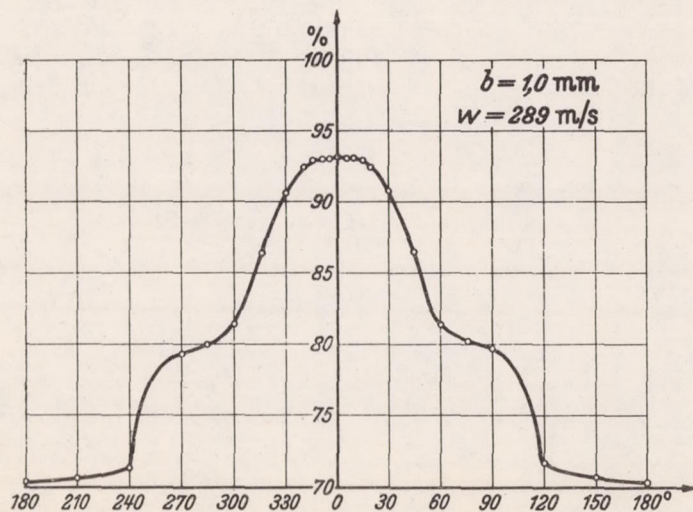

Figure 45.-Design 1; effect of flow direction.

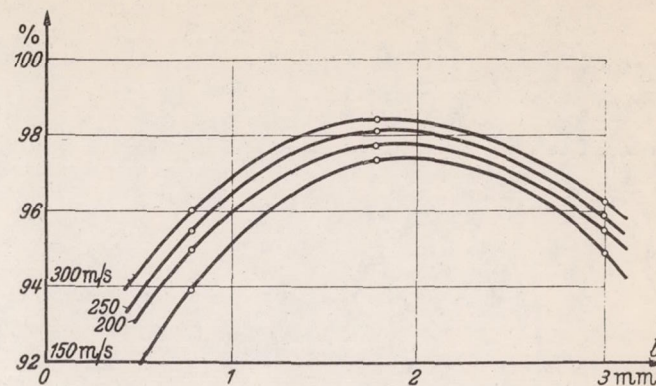

Figure 44.- Results with design 1.

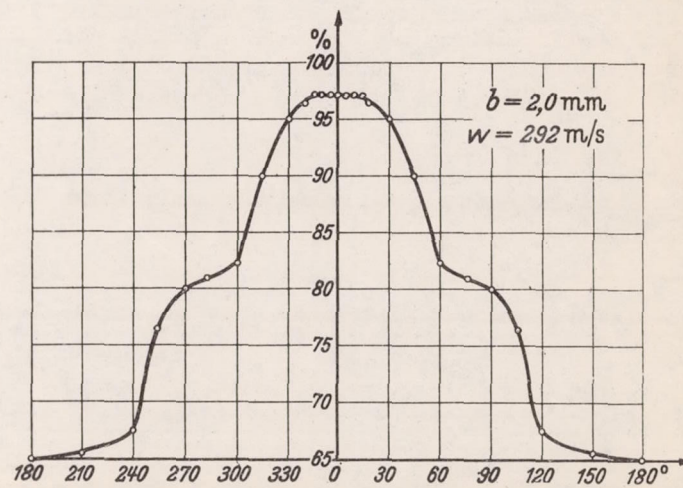

Figure 46.-Design k(Cu--Ko); effect
of flow direction.

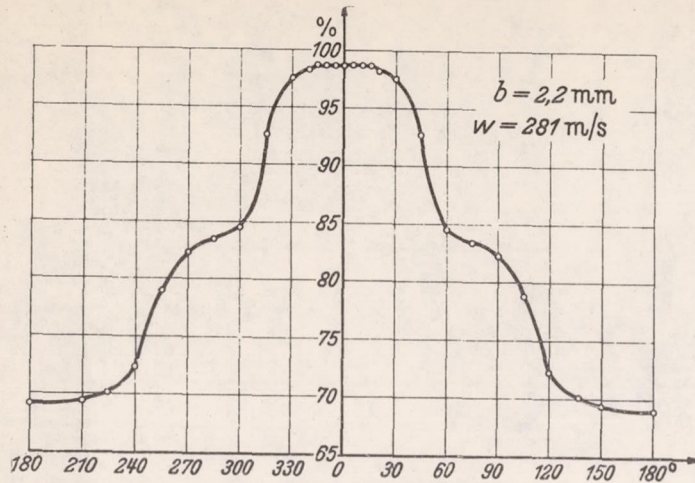

Figure 47.- Design k (Fe--Ko); effect of flow direction.

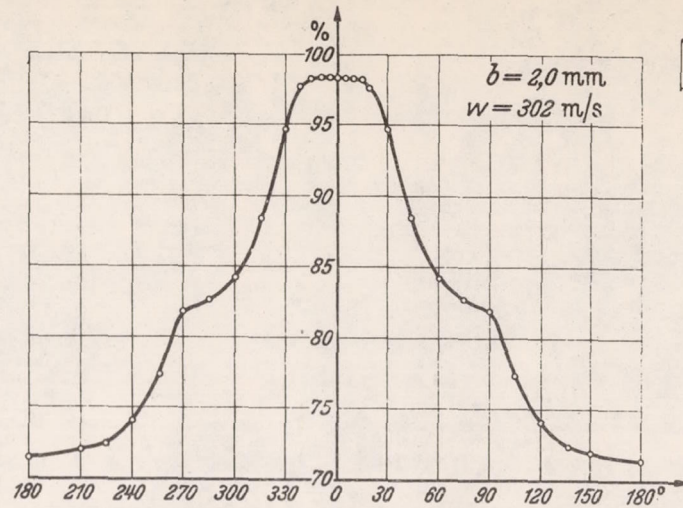

Figure 48.- Design l ; effect of flow direction.

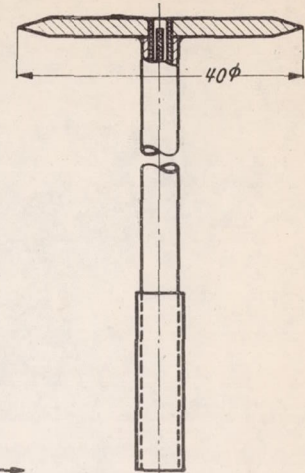

Figure 51.- Plate thermometer.

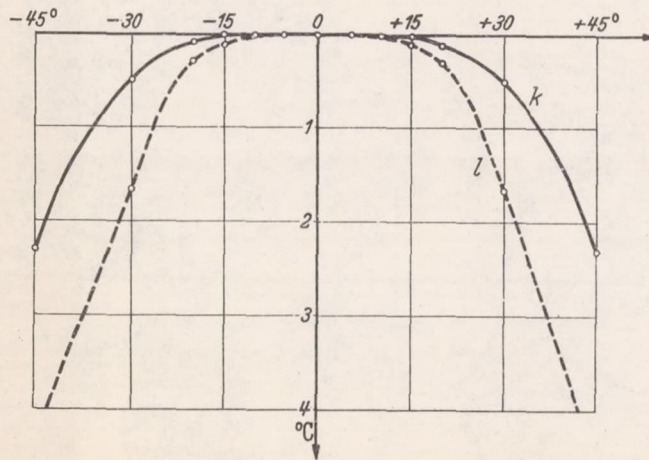

Figure 49.- Designs k and l; effect of flow direction between +45°, -45.

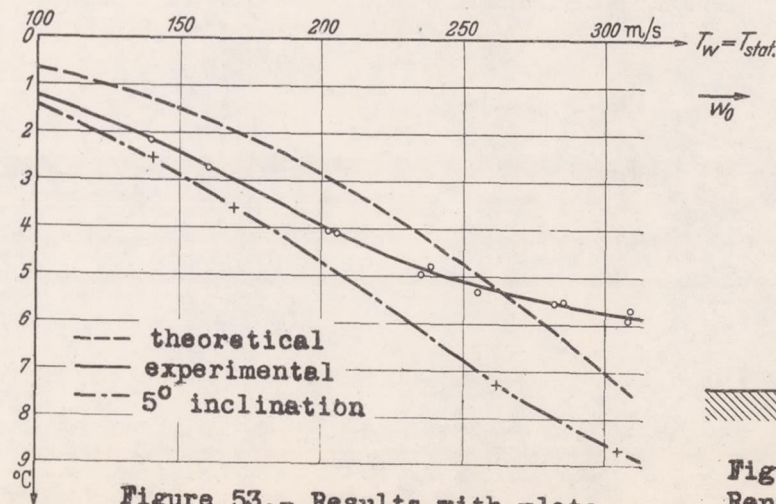

Figure 53.- Results with plate thermometer.

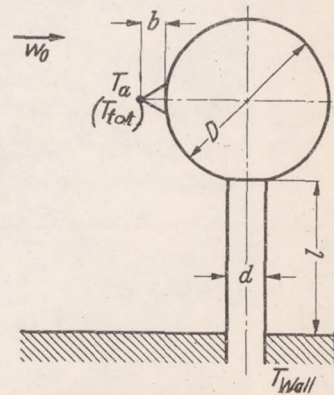

Figure 50.- Representation of similitude.

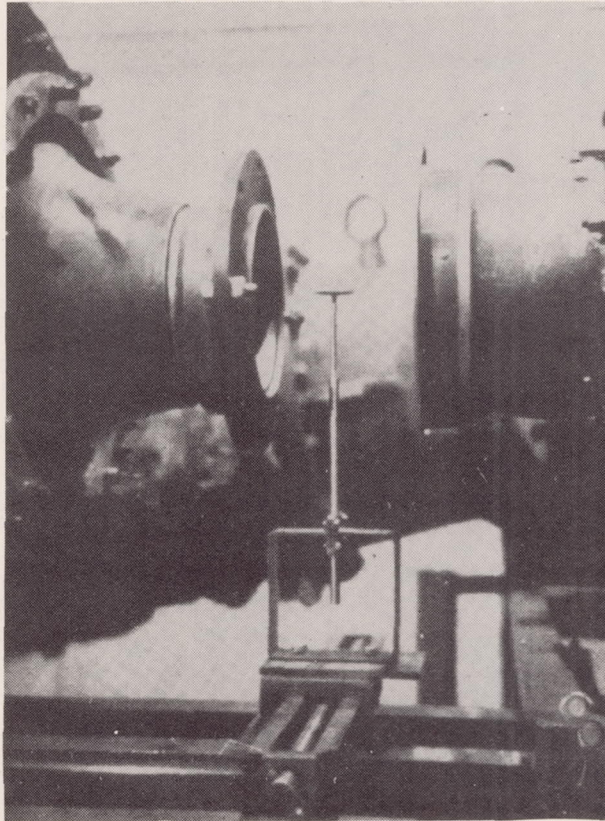

Figure 52.-Method of mounting
plate thermometer.