

L.M.A.R.

~~31015~~

~~68~~

~~68~~

TECHNICAL MEMORANDUMS
NATIONAL ADVISORY COMMITTEE FOR AERONAUTICS

No. 908

TWO-STROKE-CYCLE ENGINES WITH UNSYMMETRICAL CONTROL DIAGRAM

(Supercharged Engines)

By J. Zeman

Automobiltechnische Zeitschrift,
Vol. 41, No. 16, August 25, 1938

Washington
September 1939



NATIONAL ADVISORY COMMITTEE FOR AERONAUTICS

TECHNICAL MEMORANDUM NO. 908

TWO-STROKE-CYCLE ENGINES WITH UNSYMMETRICAL CONTROL DIAGRAM*
(Supercharged Engines)**

By J. Zeman

INTRODUCTION

The exhaust port in 2-stroke-cycle engines with symmetrical control diagrams (fig. 1) must always be higher than the scavenging port because of the exhaust lead. In Diesel engines and in many Otto engines of the 2-stroke-cycle type the width of the exhaust port is also greater than that of the scavenging port; hence the time area for the exhaust is in all cases substantially greater than for the scavenging air inlet. In consequence, no appreciable pressure rise can occur in the cylinder during scavenging, and if it should happen, it is approximately equalized again to atmospheric pressure by the still open exhaust port after termination of scavenging. For that reason, it is admissible in mathematical studies of scavenging to equate the pressure in the cylinder to atmospheric pressure. This premise and the further one, that the laws of discharge applicable to uniform flows could be used as a basis for the scavenging process - this assumption is doubted with apparent justification, in reference 3 - have led to methods of calculation for the port dimensions (and all quantities related thereto) which, with the application of the correction factors obtained from actual engines, have given sufficiently exact results (reference 11).

The introduction and development of loop scavenging have so stimulated the utilization of the cylinder chamber that the mean pressure now reaches approximately the same

*"Zweitaktmaschinen mit unsymmetrischen Steuerdiagrammen." Automobiltechnische Zeitschrift, vol. 41, no. 16, August 25, 1938, pp. 420-34.

**In this report an engine is termed "supercharged" when the cylinder pressure rises during scavenging and exceeds atmospheric pressure at start of compression.

value as for 4-stroke-cycle engines, if the part of the stroke lost through the ports is taken into account. If a further rise of mean pressure is desired, unsymmetrical control diagrams (fig. 2) must be resorted to, for supercharging. The constructive means, serving for this purpose, are:

- 1) Interposition of an automatic or controlled closing device ahead of the elevated scavenging ports (Sulzer, Atlas-Diesel, Nohab, Fiat, etc.);
- 2) Disposition of a controlled closing device behind the scavenging ports (M.A.N.);
- 3) Use of valve-scavenging, sleeve-valve, double-piston, or auxiliary-reciprocating engine (Junkers, Doxford, Burmeister and Wain, Ceska Zbrojovka).

Except for installing an automatic valve in the scavenging air duct, the unsymmetry in all cases is achieved through the use of two mutually displaced crank gears or one crank gear and a rotary control shaft.

As no investigation of supercharging in 2-stroke-cycle engines has been published up to the present, this article is an attempt in that direction, with a view to establishing the mathematical principles and the constructive rules for the design of such engines.

In 2-stroke-cycle engines with unsymmetrical control diagram (fig. 2), the general rule will be a greater instantaneous area for the exhaust than that for the scavenging air during the first time interval of scavenging followed by an interval during which the instantaneous area of the exhaust is smaller than that of the scavenging air, the process terminating with the scavenging port open but the exhaust port closed. At first one is tempted to consider only the last stage as effective for the supercharge (reference 5, fig. 12). But, since by equal gas volume per second passing through scavenge and exhaust port, the pressure drop at the smaller opening is greater; this very fact indicates that some significance attaches to the middle stage also. And this suspicion grows when reasoning that the time interval of the last stage can be but small by the usual arrangements and hence render no effective supercharge possible. So the first consideration will have to concern the pressure distribution in the cylinder during scavenging and for open as well as for closed exhaust.

CYLINDER PRESSURE DURING SCAVENGING

In the following it is temporarily assumed that the lead of the exhaust has released the cylinder charge enough so that approximately atmospheric pressure prevails in the cylinder when scavenging starts. Cases where no such time interval is provided for the exhaust lead will be treated later on.

The flow through the cylinder is then such that, owing to the pressure gradient between receiver and cylinder, the scavenging medium is accorded the inflow velocity at which it streams through the scavenging ports. This velocity is lost entirely or partly in the cylinder through friction and turbulence. For expelling residual gases and scavenging air through the exhaust ports, it again requires a pressure gradient between cylinder and exhaust collector which must be contested by the pressure rise caused by the inflowing scavenging air.

On account of the short time interval available, no appreciable heat exchange is expected between charge and cylinder wall (as proved elsewhere (reference 12)).

Hence the following assumptions may be upheld:

- 1) The flow energy of the incoming scavenging air is destroyed in the cylinder. It corresponds to the process of throttling, the air temperature is the same before and after passing through the ports;
- 2) The phase change of the cylinder charge is adiabatic;
- 3) It is further presumed that Husselt's approximate theory of flow through diaphragms (reference 6) is applicable to the flow through the ports. Since sharp-edged ports are more like diaphragms than nozzles and this theory has proved satisfactory in similar cases (reference 13), this assumption seems well founded, although it will be checked by test.

Notation

- A, constant, according to equation (16) or (19).
- B, constant, according to equation (17) or (20).
- B, quantity of fuel (kg) per kg mixture.
- D, cylinder diameter, (m).
- G, weight, (kg).
- G_a , gas volume leaving cylinder, (kg).
- G_{aufl} ,* that part of G_s which raises the pressure in the cylinder from P_n to P_v , (kg).
- G_e , the part of G_{sp} remaining in cylinder at end of scavenging, (kg).
- $G_n = G_{aufl} + G_e$; air-gas mixture available for combustion, (kg).
- G_s , air (mixture) volume entering the cylinder, (kg).
- $G_{sp} = G_s - G_{aufl}$, the part of G_s serving for scavenging the cylinder, (kg).
- P, pressure in cylinder, (kg/m²).
- P_a , pressure in cylinder at opening of scavenge port, (kg/m²).
- P_g , mean pressure corresponding to blower performance referred to section and stroke of power piston, (kg/m²).
- P_{gt} , mean pressure corresponding to the theoretical blower output, (kg/m²).
- P_1 , pressure of the atmosphere (= 10,000 kg/m²), (kg/m²).
- P_n , minimum cylinder pressure, (kg/m²).
- P_s , scavenge pressure (pressure in scavenge air receiver), (kg/m²).

*aufl is boost.

- P_u , pressure in exhaust collector, (kg/m²).
 P_v , cylinder pressure at closing of scavenge ports, (kg/m²).
 R , (for air = 29.3) gas constant.
 S_a , referred time interval of exhaust lead.
 T , general temperature, mean temperature of cylinder charge, (°K).
 T_a , cylinder temperature at opening of exhaust port, (°K).
 T_s , temperature of scavenging air in the receiver, (°K).
 V , momentary piston displacement, $dV = \frac{\pi D^2}{4} ds$
 $= -\frac{\pi D^2}{4} dy$ and $= -\frac{\pi D^2}{4} (dx + dy)$, (m³).
 V_a , volume of charge leaving the cylinder, (m³).
 V_g , volume of G_s referred to state of atmosphere, (m³).
 V_s , volume of charge entering cylinder, (m³).
 V_{sp} , volume of G_{sp} referred to P_n , (m³).
 V_v , volume of cylinder at closing of scavenge ports, (m³).
 V_o , volume of compression chamber, (m³).
 V_1 , auxiliary concept (fig. 11), (m³).
 b_a , width of exhaust port, (m).
 b_e , effective fuel consumption, (kg/hp-h).
 b_i , indicated fuel consumption, (kg/hp-h).
 b_s , width of scavenge port, (m).
 f_a , momentary open exhaust section, (m²).
 f_s , momentary open scavenge section, (m²).

$$f_{a\text{rel}} = f_a/D \cdot S$$

$$f_{s\text{rel}} = f_s/D \cdot S$$

g , gravity, (m/s^2).

h_a , exhaust-port height measured from dead center,

$$h_{arel} = h_a/s, \quad (m).$$

h_s , scavenge-port height, measured from dead center,

$$h_{srel} = h_s/s, \quad (m).$$

$$k = V_{sp}/\frac{\pi D^2}{4} s.$$

$$k_2 = \left[\frac{\pi D^2}{4} (s - h_a) + V_0 \right] / \frac{\pi D^2}{4} s, \quad \text{cylinder volume re-}$$

ferred to stroke volume at start of exhaust opening.

$$k_3 = V_v/\frac{\pi D^2}{4} s$$

l_a , momentary free height of exhaust port, measured from control edge of piston, (m).

l_s , momentary free height of scavenge port, measured from control edge of piston, (m).

$$l_{arel} = l_a/s$$

$$l_{srel} = l_s/s$$

n , engine r.p.m.

p , pressure (other than as under P), (kg/cm^2).

p_e , mean effective pressure, (kg/cm^2).

p_{er} , mean effective pressure without subtraction of blower performance, (kg/cm^2).

p_i , mean indicated pressure, (kg/cm^2).

s , piston stroke, for reciprocating engines: total stroke, (m).

v , mean specific volume of cylinder charge, (m^3/kg).

v_s , specific volume of scavenging air in the receiver, (m^3/kg).

- \bar{v} , specific volume of scavenging air after passing through scavenge ports, (m^3/kg).
- v_{sp} , specific volume of scavenging air in cylinder, referred to P_n , (m^3/kg).
- x , piston travel, computed from top center, (m).
- y , piston travel, computed from bottom center, (m).
- z , time, (sec.).
- α , or arc, crank angle, (deg.).
- $\zeta_a = b_a/D$
- $\zeta_s = b_s/D$
- η_g , total blower efficiency.
- η_m , mechanical efficiency of the engine.
- κ (= 1.4 for air) specific-heat ratio.
- λ connecting-rod ratio.
- ψ Husselt's discharge factor (reference 6).
- ψ_u Husselt's discharge factor for the exhaust port.
- ψ_s Husselt's discharge factor for the scavenge port.

The subscript "rel" indicates: interrupted by (referred to $\frac{\pi D^2}{4} s$ (f, h, and l excepted)).

The dash ' indicates: interrupted by (relative to)

$$\left[\frac{s - y}{s} + \frac{V_o}{\pi D^2/4} \right] \text{ and } \left[\frac{s - x - y}{s} + \frac{V_o}{\pi D^2/4} \right] \text{ respectively.}$$

The pressure change dP in time interval dz in the cylinder can be determined from the gas volume inducted in the cylinder dG_s , from the gas leaving the cylinder dG_a , and the volume change dV caused by piston stroke.

$$dG_s = \psi_s f_s \sqrt{\frac{P_s}{v_s}} dz \quad (1)$$

Aside from cylinder pressure, back pressure, and slot area, the gas volume leaving through the exhaust ports is also dependent on the exhaust-gas temperature and specific volume, i.e., whether residual gases, scavenging air, or a mixture is exhausted.

Assuming the state of exhaust gas to be identical with the mean state of the charge, we have

$$dG_a = \psi_a f_a \sqrt{\frac{P}{v}} dz \quad (2)$$

Because of

$$P_s v_s = P \bar{v} \quad (3)$$

owing to assumption (1) dG_s has, after entering the cylinder, the volume

$$dV_s = \bar{v} dG_s = \frac{\psi_s}{P} P_s f_s \sqrt{P_s v_s} dz \quad (4)$$

while the volume of the gas leaving the cylinder referred to mean condition in the cylinder is:

$$dV_a = v dG_a = \psi_a f_a \sqrt{P v} dz \quad (5)$$

The inflowing gas volume displaces part of the charge, hence has a volume-decreasing effect; the outflowing gas, a volume-increasing effect. Then the charge remaining in the cylinder goes through the same phase change as if the volume had changed by the amount of

$$dV_{total} = -dV_s + dV_a + dV \quad (6)$$

According to assumption 2, it is:

$$dP = -\kappa \frac{P}{v} dV_{total} \quad (7)$$

Hence from equations (4) to (7) follows the phase equation

$$P v = R T \quad P_s v_s = R T_s \quad (8)$$

and from the relation between time, r.p.m., and crank setting:

$$dz = \frac{30}{n \pi} d\alpha \quad (9)$$

$$\frac{dP}{d\alpha} = \left[\frac{30\kappa}{n\pi} \sqrt{RT_s} P_s \right] \psi_s \frac{f_s}{V} - \left[\frac{30}{n\pi} \sqrt{R} \right] \sqrt{T} P \psi_a \frac{f_a}{V} - \frac{\kappa P}{V} \frac{dV}{d\alpha} \quad (10)^*$$

In this equation the bracketed factors are invariable for a certain case; f_s/V and f_a/V , as well as $\frac{1}{V} \frac{dV}{d\alpha}$ are geometric functions of α and readily obtainable. ψ_s is dependent on the ratio $\frac{P}{P_s}$, ψ_a on ratio $\frac{P_u}{P}$; if P_s and P_u are considered constant, then ψ_s and ψ_a are functions of PT as mean temperature of the cylinder content is dependent on the temperature of the residual gases, on the scavenging-air temperature, on the mixture ratio of scavenging air: residual gas (i.e., from the scavenging-air volume entered and left up to the particular time interval and from the residual-gas volume discharged up to the same instant), and lastly, on the momentary cylinder pressure P . Although the presentation of this relation involves no fundamental difficulty, it nevertheless makes the calculation extremely complicated. However, by virtue of the available data on the temperature during scavenging (reference 5) it is always possible to enter the relative value in equation (10) by estimation. Bearing further in mind that the maximum which T may attain, is the residual-gas temperature (about 500°C .) while the lowest possible temperature must always be higher than T_s (about $T_s = 273^\circ + 50^\circ$ to 100°), a variation of T within the bounds of 773°abs. and 403°abs. , i.e., a variation of \sqrt{T} within the limits of 28 and 20 may be counted on. Hence, in order to avoid the difficulties introduced when allowing for the variability of T , it is suggested to employ a constant mean value of T , so that in general \sqrt{T} should range at around 23-25. Then we have as invariable values

*This equation (10) is the basic equation for all charging and discharging processes in 2- and 4-cycle engines. If $f_s = 0$, the equation presents the pressure course during exhaust (in 2- and 4-cycle engines). If $f_a = 0$, it is the equation for the pressure during the suction stroke in 4-cycle engines and for the pressure during the pure charging period in 2- and 4-cycle engines. If, finally, f_s and $f_a = 0$, it presents the pressure equation during compression and expansion, respectively. The combustion period alone is impossible to represent by (10), because in its formulation heat input and output were excluded conformably to assumption.

$$\frac{30\kappa}{n\pi} \sqrt{R T_s} P_s = \frac{72.5}{n} \sqrt{T_s} P_s$$

$$\frac{30\kappa}{n\pi} \sqrt{R T} = \frac{72.5}{n} \sqrt{T_{\text{mean}}}$$

and equation (10) assumes the form:

$$\frac{dP}{d\alpha} = \left[\frac{72.5}{n} \sqrt{T_s} P_s \right] \psi_s \frac{f_s}{V} - \left[\frac{72.5}{n} \sqrt{T_{\text{mean}}} \right] P \psi_a \frac{f_a}{V} - \kappa \frac{P}{V} \frac{dV}{d\alpha} \quad (11)$$

A general solution of this differential equation is out of the question, especially as the functional relationship between ψ , f , V , and α and P , respectively, does not lend itself to convenient interpretation except in graphical or tabulated form. Hence it is recommended to divide the zone of the crank circle in question into a number of parts (not necessarily of equal size) and to determine $P \frac{dP}{d\alpha}$ in the center of each part for a number of ordinate values (which with given P is directly possible). In this manner it is possible, as indicated in figures 5 and 7, starting from the known initial state to obtain a broken line which hugs the actual integral curve with any approximation (depending on the size of the parts). The execution of the process of solution, which for special reasons affords in the present case accurate results even with relatively rough divisions is taken up again later on.

The general equation (11) is, for practical purposes, modified. In scavenging-slot engines the instantaneous port area, f can be referred to diameter and stroke:

$$f_s = D s f_{s\text{rel}}^* \quad (12)$$

$$f_a = D s f_{a\text{rel}} \quad (13)$$

In addition to this:

*Any eventually existing inclination of scavenging ports toward the axis of the cylinder is to be allowed for. (See also reference 11.)

$$V = (s - y) \frac{\pi D^2}{4} + V_0$$

or

$$V = (s - x - y) \frac{\pi D^2}{4} + V_0$$

for double-piston-type engines, where as a rule V_0 can be appraised at 6 percent of the displacement:

$$\left. \begin{aligned} \text{or} \quad V &= \frac{\pi D^2}{4} s \left\{ \frac{s - y}{s} + 0.06 \right\} \\ V &= \frac{\pi D^2}{4} s \left\{ \frac{s - x - y}{s} + 0.06 \right\} \end{aligned} \right\} \quad (14)$$

Thus equation (11) assumes the form

$$\begin{aligned} \frac{dP}{d\alpha} &= \left[\frac{72.5}{nD} \frac{4}{\pi} \sqrt{T_s} P_s \right] \psi_s f_{s'}'_{rel} - \\ &- \left[\frac{72.5}{nD} \frac{4}{\pi} \sqrt{T_{mean}} \right] P \psi_a f_{a'}'_{rel} + P \left(\frac{dy}{s} \right)' \frac{1}{d\alpha} \end{aligned}$$

or

$$\frac{dP}{d\alpha} = A \psi_s f_{s'}'_{rel} - B P \psi_a f_{a'}'_{rel} + \kappa P \left(\frac{dy}{s} \right)' \frac{1}{d\alpha} \quad (15)$$

where

$$A = 92.3 \frac{\sqrt{T_s} P_s}{nD} \quad (16)$$

$$B = 92.3 \frac{\sqrt{T_{mean}}}{nD} \quad (17)$$

For rectangular ports, it is:

$$f_{s'}'_{rel} = \zeta_s \zeta_{s'}'_{rel} \quad f_{a'}'_{rel} = \zeta_a \zeta_{a'}'_{rel}$$

hence

$$\frac{dP}{d\alpha} = A \psi_s \zeta_s \zeta_{s'}'_{rel} - B P \psi_a \zeta_a \zeta_{a'}'_{rel} + \kappa P \left(\frac{dy}{s} \right)' \frac{1}{d\alpha} \quad (18)$$

where

$$\Lambda = 92.3 \zeta_s \frac{\sqrt{T_s P_s}}{n D} \quad (19)$$

$$B = 92.3 \zeta_a \frac{\sqrt{T_{\text{mean}}}}{n D} \quad (20)$$

Equation (11) can be simplified similarly for valve-scavenging engines, although it is not shown here.

If the scavenge ports for a certain operating state are too great it may happen at the end of the scavenge cycle that the pressure P in the cylinder rises higher than the scavenging pressure P_s , in which case the charge from cylinder into the scavenge-air receiver is reduced. Conformably to equation (5) the air volume leaving through scavenging ports in time interval $d z$ is then:

$$d \bar{V}_a = \bar{\psi}_s f_s \sqrt{P v} d z \quad (1a)$$

whereby $\bar{\psi}_s$ is dependent upon the ratio P_s/P . Then equation (10) reads:

$$\begin{aligned} \frac{d P}{d \alpha} = & - \left[\frac{30 \kappa}{n \pi} \sqrt{R} \sqrt{T_{\text{mean}}} \right] P \bar{\psi}_s \frac{f_s}{V} - \\ & - \left[\frac{30 \kappa}{n \pi} \sqrt{R} \sqrt{T_{\text{mean}}} \right] P \bar{\psi}_a \frac{f_a}{V} - \kappa \frac{P}{V} \frac{d V}{d \alpha} \end{aligned} \quad (10a)$$

The constant of the first term corresponding to this state is therefore equal to B for equation (15) and equal to $B \frac{\zeta_s}{\zeta_a}$ for equation (18).

Determination of Scavenging-Air Volume

Aside from the pressure (or the obtained terminal pressure) the inducted amount of scavenging in air must be determined also; first, with a view to the correct dimensions of the scavenging pump; second, for appraisal of the scavenging efficiency. The employed equation (1)(1a) is suitably changed to:

$$d G_s = \frac{30}{n \pi} \sqrt{\frac{P_s}{v_s}} \psi_s f_s d \alpha \quad (21)$$

which for scavenge-port type of engines gives:

$$d G_s = \frac{30}{n \pi} \sqrt{\frac{P_s}{v_s}} D_s \psi_s f_{srel} \quad (22)$$

Knowing this, the pressure distribution ψ_s can be established and equation (22) integrated, which is preferably carried out in sections, whereby the same divisions as for the pressure are employed, i.e., determined for each section

$$\Delta G_s = \frac{30 D_s}{n \pi} \sqrt{\frac{P_s}{v_s}} \psi_s f_{srel} \Delta \alpha \quad (23)$$

and add up the obtained partial amounts.

Experimental Check of Equation (10)

This check was deemed necessary for two reasons: first, to ascertain whether objections raised against the use of stationary discharge formulas in the scavenging process are founded, then to verify the applicability of Nusselt's discharge factor to the flow through ports. A Junkers double piston engine, type HK 65, engine No. 5408, was available for the test. Its principal data were (a similar engine is described in reference 5):

Bore	65 mm
Stroke of bottom piston	120 mm
Stroke of top piston	90 mm
Total stroke	210 mm
Crank setting	15°

Form, dimensions, and position of ports are indicated in figure 3. The charging pump was cut out by removal of the valves and replaced by an electrically driven Roots blower. The inducted air volume was measured with Manoschek type oil oscillation gas meter. An equalizing tank

of 600 liters capacity was mounted to the pipe line between blower and engine. Unfortunately, lack of space prevented mounting the tank closer to the engine, so that pressure fluctuations were unavoidable despite the fact that the whole crankcase chamber served equally as receiver. The Diesel engine was driven externally, the cylinder chamber was recorded by Mahak indicator substituting for the injection nozzle. Figure 4 illustrates one of the diagrams as obtained at different scavenging pressures and r.p.m. For the mathematical check the stroke curves of both pistons were plotted as fractions of the total stroke. Then the ports on the engine were recorded and plotted suitably (height in fractions of total stroke, widths in fractions of cylinder diameter). The result was figure 3, which gives for every crank setting the momentarily open port areas. Putting, in addition, the distance of the dead centers at

$$1.06 = \frac{s \frac{\pi D^2}{4} + V_0}{s \pi D^2/4}$$

the value $\frac{s - x - y}{s} + 0.06$ can be read direct from the chart. For lack of space the distance 1.06 has been shortened to 0.25, for which reason it is necessary to add 0.81 to the recorded figures. The results are appended in table 1. The chart also gives the value $\frac{\Delta x + \Delta y}{s}$ for each part, thus affording the geometric principles for the calculation.

The experimental conditions (fig. 4) further yield:

$$A = 92.3 \frac{\sqrt{T_s} P_s}{n D} = 92.3 \frac{\sqrt{363} \times 14750}{560 \times 0.065} = 713000 \quad (16)$$

Since there is no ignition or combustion, $\sqrt{T_{mean}}$ may be approximated equal to $\sqrt{T_s}$ during the scavenging cycle. Then:

$$B = 92.3 \frac{\sqrt{T_{mean}}}{n D} = 92.3 \frac{\sqrt{333}}{560 \times 0.065} = 48.3 \quad (17)$$

The scavenging ports being too great for this revolution speed, scavenging air flows back into the receiver at termination of the scavenging cycle. For this stage, A is

replaced by $B P$ in equation (15). The further procedure with consideration to equation (15) (ψ values to be taken from reference 6) is forthwith apparent from table 1 and figure 5. The latter also shows the actually recorded pressure variation taken from figure 4 and reduced to crank angle as comparison. The agreement of the two curves is perfect at the beginning and in the middle of the cycle; discrepancies occur at the end of scavenging which can be summarily explained as being due to the sinking of the scavenging pressure during this time interval and to inaccuracies in plotting. The first task in computing the volume of scavenging air is to define

$$v_s = \frac{29.3 \times 363}{14750} = 0.72 \text{ m}^3/\text{kg}$$

whence the constant in equation (23):

$$\frac{0.065 \times 0.21 \times 30}{560 \pi} \sqrt{\frac{14750}{0.72}} \Delta \alpha \quad \text{becomes equal to}$$

0.002617 or 0.005234, according to whether $\Delta \alpha = 0.0785$ or 0.157.

This constant, multiplied by $f_{srel} \psi_s$ gives the amount of air inducted during each stage. Its sum in the amount of 0.003406 kg/stroke is in good agreement with the measured value of 0.00365 kg/stroke.

This affords proof of the applicability of equation (10). As this equation contains no experimentally obtained correction factors, it constitutes an added approval of the applicability of Nusselt's discharge factor for similar cases.

"Stationary" or "Dynamic" Treatment of Scavenging Cycle

The accord of the true with the theoretical pressure distribution on the basis of stationary discharge formulas makes it necessary to regard this problem also (reference 3).

Fundamentally it involves two questions, to wit:

- 1) Is the effect of acceleration so great that an appreciable departure from the law of discharge for stationary conditions is imminent?
- 2) Is the flow in the cylinder like that in a stationary flow?

To question 1) - according to figure 5 no such departure is discernible in the present case. Admittedly the conditions in the Junkers engine are particularly favorable to the extent that the scavenging ports connect directly with larger chambers serving as receivers. Then it is, of course, always attempted to arrive with a scavenge port greater than the maximum port section. But even if this were otherwise, the value $\alpha = w_0 t_0 / l$ (the criterion for the departure from the stationary discharge formulas, equation (15) in reference 3) is usually so great* in the usual designs that any appreciable effect would have to be considered as special case.

To question 2) - there is no doubt that here a non-stationary process of the most complex kind, is involved. Hence the general acceptance in practice that reliable tests on scavenging quality must be made while the engine is running and that experiments on stationary models (for instance, reference 4) merely afford rough reference data.

Scavenging and Boosting

With the foregoing result of being able to predict the pressure curve and the scavenge air input in a certain case, it is made possible to investigate the problem of obtainable power and best arrangement. In the face of the many variables involved - constructional arrangements, dimensions of inlet and exhaust ports and their position in the control diagram, amount of scavenging air and head scavenging pressure, type and efficiency of blower employed,

*Normally the rate of inflow w_0 assesses at about 180 m/s the total angle during which the scavenge ports are open, amounts to about 100°, so that the port opening lasts 50° or $t_0 = \frac{60}{n} \frac{50}{360} = \frac{8.3}{n}$; hence $\alpha = \frac{1500}{l n}$. A design less

promising in this respect is illustrated in fig. 121 of reference 11, where $n = 500$, $l = 0.22$; hence

$$\alpha = \frac{1500}{500 \times 0.22} = 13.6.$$

and, lastly, the scavenging method - it is admittedly unlikely that there is only one favorable solution. The present article is therefore restricted to an examination of the fundamental relationship of various variables, while attempting for the rest to survey the other relations from the data.

To begin with, we therefore limit the variables by fixed assumptions to two, namely, scavenging pressure and volume of scavenging air. The effect of change of these quantities on the engine power is explored. To avoid unnecessary difficulties in the calculation, a simple design is chosen: a single-piston engine with $n D = 100$ (reference 11), conventional piston-controlled exhaust ports, inlet ports with sleeve valve which controls the start of inlet. The relative width and height of the rectangular exhaust ports is 0.9 and 0.14, respectively. The dimensions of the scavenging ports and of the sleeve valve are such as to satisfy two obvious conditions: 1) the sleeve valve opens after the cylinder charge has been sufficiently relieved through the exhaust; 2) the time area of the inlet is so designed that a return of scavenge air in the receiver is precluded or is at least so small as to induce no appreciable charging losses. The instant of opening of the rotary sleeve valve can be defined by computing the time area for the exhaust lead. To check the compliance with condition 2) the pressure curve during scavenging must be known.

The opening moment of the sleeve valve can be accurately determined from the exhaust-port dimensions by means of equation (13) ($l_s = 0$) and approximately with equation (6a) of reference 11. In the latter case, the equation

$$\frac{\xi_a}{n D} S_a = \frac{k_a \pi^2}{60 \psi} \frac{1}{\sqrt{2} T_a} \frac{1}{\kappa - 1} \left\{ (P_a/P)^{\frac{\kappa-1}{2\kappa}} - 1 \right\}^*$$

must be evaluated.

*This equation is given incorrectly in reference 11 as a result of interchanged numerator and denominator of the factor $\frac{2}{\kappa - 1}$. The wording above is correct, but it should

be observed that the ψ value according to Musselt already contains the factors μ and $\sqrt{2} g$. The equation is approximately valid only, because it premises the cylinder pressure in excess of the critical during the whole exhaust cycle.

With the assessed values: $P_a = 40,000 \text{ kg/m}^2 \text{ abs}$;
 $T_a = 873^\circ \text{ K}$; the ψ value according to Nusselt = 1.748;
 relief pressure $P = P_n = P_1 = 10,000 \text{ kg/m}^2$ and $k_2 =$
 $\frac{0.86 + 0.06}{1} = 0.92$, we have

$$S_a = 0.031$$

The shaded area in figure 6 must correspond to this figure (note the scales). In this manner the moment of opening of the sleeve valve is ascertained at 21° B.T.C. The rotatory speed of the inlet sleeve valve, that is, the slope of the opening line, is assumed to be known. With a 17-percent scavenging-port height at $\zeta_s = 0.8$, for instance, figure 6 can be completely plotted. The evaluation of this diagram affords the lines 2 to 7 and 14, 15 in table 2. Then the pressure curve for the scavenging pressures cited in table 3 is determined. Table 2 and figure 7 contain the complete calculation for $P_s = 15,000 \text{ kg/m}^2$, for the other scavenging pressures only the pressure curve is indicated in figure 7.

As regards the processes accompanying scavenging, table 2 (and specifically the values on line 11, 12, 13, and 16, which together form the values in line 17) is very instructive.

To illustrate: If the numerical value of line 13 is positive great at high positive values of line 17, it means that the pressure rise is due to the preponderance of inflow. But if the value in line 13 is small, zero, or negative even, the value in line 16 positive, then the pressure rise is due to the compression of the charge as a result of piston motion.

The findings are as follows: As for the Junkers engine the curve for the pressure rise is made up of three pieces. The opening of the scavenge port is immediately followed by a steep pressure rise as a result of the inflowing scavenging air. In the central portion, the pressure curve is flat, with a cylinder pressure about the same as that for a stationary cylinder flow with wide-open exhaust and scavenging ports (values in line 13 near zero). Toward the end of the cycle the pressure rises anew as a result of the compression due to piston motion and because of the fact that the charge flow-off is prevented by the rapidly reduced exhaust area.

Since the terminal boost pressure at $P_s = 20,000 \text{ kg/m}^2$

is lower than P_s , at $P_s = 15,000 \text{ kg/m}^2$ about equal to P_s , but at low scavenging pressures higher than P_s , the port dimensions are in this respect correct or rather too small for scavenging pressures above $15,000 \text{ kg/m}^2$, but too great for those below $15,000 \text{ kg/m}^2$. As a general rule, low scavenging pressures require small port area.

Another fact established is that, apart from temperature, the head of the boost pressure is not solely decisive for the suitability of the arrangement, but also the moment, or rather, the piston setting at which it is obtained. All boost pressures located on the same compression curve are equivalent (Figs. 8 and 9). Hence the desirability to reach maximum boost pressures as early as possible. In this respect, engines with controlled-exhaust port or valve-scavenging engines in which the scavenging air is inducted through the port, and the exhaust evacuated through valves, as well as double-piston and auxiliary-piston engines are superior.

The scavenging air input is preferably referred to the displacement, in order to avoid the assumption of definite dimensions for stroke and bore in this general example.

Equation (23) then takes the form

$$\frac{\Delta G_s}{\frac{\pi D^2}{4} s} = \Delta G_{s\text{rel}} = \left[\frac{120}{\pi^2} \frac{\xi_s}{n D} \sqrt{\frac{P_s}{v_s}} \right] \psi_s v_{s\text{rel}} \Delta \alpha \quad (23a)$$

For instance: for $P_s = 15,000 \text{ kg/m}^2$ and $T_s = 343^\circ \text{ abs.}$:

$$v_s = \frac{R T_s}{P_s} = \frac{29.3 \times 343}{15000} = 0.67$$

hence

$$\left[\frac{120}{\pi^2} \frac{\xi_s}{n D} \sqrt{\frac{P_s}{v_s}} \right] = 14.58$$

Results and intermediate values are given in figure 10 and table 3.

A part G_{boost} of the total inducted scavenging air

G_s is utilized to boost the cylinder pressure from P_n to P_v , while the remainder of the scavenging air G_{sp} scavenges the cylinder. This means that G_{sp} of itself could not produce a pressure rise in the cylinder, whence the incoming G_{sp} is faced by an identically great out-flowing volume.

A picture of the course and the success of scavenging may now be obtained by separating the processes which in reality are contemporary with respect to time and space: Visualize in the cylinder a very thin, floating piston serving merely as partition (fig. 11), whose position is governed by the condition of equal pressure above and below it. Then assume that G_{boost} enters in chamber 1, G_{sp} in chamber 2 with the same time rate of distribution as occurs in reality. The pressure in both chambers rises from P_n to P_v . The pressure is plotted as rising curve in relation to the auxiliary piston setting. Note that the pressure rise in chamber 2 is, conformably to assumption, due solely to the volume change caused by the auxiliary piston, not to G_{sp} . After termination of the process the auxiliary piston is removed and the charge mixed. Since the total input is the same as in reality, the amount of fresh air in the cylinder will be the same in both cases, with the provision, of course, that the quality of scavenging remains unchanged. Following a temporal separation, the process then is as follows:

1. Phase: The auxiliary piston is directly at the cover, G_{sp} flows through the ports and scavenges the cylinder. The pressure in the cylinder is unalterably equal to P_n . At the end of this phase exhaust and inlet ports close.
2. Phase: G_{boost} enters chamber 1, the pressure in both chambers rises from P_n to P_v . Then the auxiliary piston moves, the terminal state is the same as before, if the scavenging efficiency is maintained. At this stage the relation between auxiliary piston position and cylinder pressure is readily obtainable, provided the cylinder volume remains always equal to V_0 .

Having assumed adiabatic change of state in all chambers, that is, in chamber 2 also (heat exchange between fresh air and rest gas outwardly does not appear) it is at any instant

$$(V_V - V_1)^{\kappa} P = V_V^{\kappa} P_n; V_1 = V_V \left[1 - (P_n/P)^{\frac{1}{\kappa}} \right] \quad (24)$$

Consider, then, any instant of phase 2: The pressure in both chambers is P , the volume of chamber 1 is V_1 . As the auxiliary piston moves V_1 is changed by dV_1 in time interval dz , at the same time as dG_{boost} enters. According to equation (3) this quantity of air has a volume

$$dV_{\text{boost}} = \frac{P_s v_s}{P} dG_{\text{boost}} \quad (25)$$

hence displaces an identical volume of the charge from chamber 1. Thus the charge volume of chamber 1 underwent a change amounting to

$$dV_{1\text{total}} = dV_1 - dV_{\text{boost}} \quad (26)$$

This change of phase also is adiabatic. Hence (see equation (7)):

$$dV_{1\text{total}} = -\frac{1}{\kappa} \frac{V_1}{P} dP \quad (27)$$

From equations (24) to (27) follows:

$$\begin{aligned} dG_{\text{boost}} &= \frac{1}{P_s v_s} \left\{ P dV_1 + \frac{1}{\kappa} V_1 dP \right\} \\ &= \frac{1}{R T_s} \left\{ d(P V_1) + \frac{1-\kappa}{\kappa} V_V dP - \frac{1-\kappa}{\kappa} V_V P_n^{\frac{1}{\kappa}} P^{-\frac{1}{\kappa}} dP \right\} \quad (28) \end{aligned}$$

which, integrated and the corresponding limits inserted, gives

$$G_{\text{boost}} = \frac{P_V V_V}{R T_s} \frac{1 - P_n/P_V}{\kappa} \quad (29)$$

Since, as a rule, it is more expedient to refer G_{boost} to the displacement, it affords with

$$k_3 = V_v / \frac{\pi D^2}{4} s, \quad \text{or} \quad k_3 = 1 - h_{srel} + V_o / \frac{\pi D^2}{4} s$$

in scavenge-port engines,

$$G_{boostrel} = k_3 \frac{P_v}{R T_s} \frac{1 - (P_n/P_v)}{\kappa} \quad (29a)$$

In the present example $k_3 = 1 - 0.17 + 0.06 = 0.89$, whence G_{boost} and consequently $G_{sp} = G_s - G_{boost}$ can be computed (table 3).

However, equation (29) holds only so long as $P_v \leq P_s$. With $P_v > P_s$; i.e., scavenging air flowing back into the receiver, the solution of G_{boost} is uncertain. It is safer then to put $P_v = P_s$.

While G_{boost} then remains completely in the cylinder, hence wholly available for combustion, G_{sp} scavenges the cylinder with result similar to the conventional 2-stroke engine with symmetrical control diagram. These conditions can be graphically represented by plotting the scavenging air volume left in the cylinder after scavenging against the scavenging medium input k in parts of the displacement, with parts by volume of cylinder displacement as usual, as ordinate scale (references 2 and 11). It yields a curve which in principle approaches, after a more or less steep rise, a horizontal line asymptotically, which theoretically should lie at distance

$$1 - h_{srel} + V_o / \frac{\pi D^2}{4} s \quad \text{from the abscissa (provided } h_s > h_a).$$

The shape of the curve is therefore dependent on the port heights and the size of the compression chamber. On the other hand, plotting the scavenging air volume remaining in the cylinder in parts of V_o , affords a release from these quantities, the asymptote lies in all cases at distance 1 from the axis of the abscissa. For the same reasons it would also be correct to plot the scavenging input in parts of V_v , but that would introduce difficulties of another kind.

For 2-stroke engines with symmetrical control diagram and crankcase scavenging pump, a series of such curves taken by List (reference 2) are available. Although the

tests serving as a basis for these curves were not made on the running engine and the altered conditions of the present example (constant scavenging pressure, higher pressure in cylinder during scavenging, etc.) undoubtedly affect the individual point on the curves, they still are representative of the fundamental shape, which, after all, is of paramount importance in a general study. Thus the curve for reverse scavenging and 1.48 bore-stroke ratio is to be used after proper conversion and careful complement for the subsequent arguments (fig. 12). Obviously it is to be noted that in 2-stroke engines with symmetrical control diagrams the volume of scavenging air is referred to the state of the atmosphere. Using the previously cited division of the scavenging process with respect to time and space in a boosting and a scavenging part as a basis, it follows that the volume is defined by the lowest cylinder pressure P_n^* and the temperature of the scavenging air in the receiver, that, according to equation (3)

$$V_{sp} = V_s \frac{P_s}{P_n} \frac{R T_s}{P_n} \quad (30)$$

whence

$$V_{sp} = G_{sp} \frac{R T_s}{P_n} \quad (31)$$

or, when resorting to the correlated values,

$$\text{Air input } k = V_{sp} \frac{\pi D^2}{4} s = G_{sp \text{ rel}} \frac{R T_s}{P_n} \quad (32)$$

The air-input factor then permits the determination of the air volume remaining in the cylinder (for instance, by means of fig. 12) from which the corresponding air weight G_e can be ascertained. The sum $G_n = G_{\text{boost}} + G_e$ represents the total result of scavenging and boosting, it is the air volume available for combustion.

In table 4 the results and several intermediate values of the calculation as applied to the example are shown,

*In the example, it is $P_n = P_1 = P_u$; this, however, need not always be the case, as explained farther on.

while figure 13 giving the same data as curves, forms the basis for the selection of the scavenging pressure. For the sum $G_n = G_{\text{boost}} + G_e$ forms the starting point for computing the indicated power, G_s and P_s are decisive for the power absorption of the blower, in conjunction with the power-plant friction they are the quantities which define the effective power and the mechanical efficiency. Obviously, their solution is contingent upon the values representing the known air-fuel ratio, and combustion as well as the compressor characteristics. It will be observed, of course, that the compressor characteristics must be already accounted for in the determination of T_s , which had been tacitly assumed in the example. Since the calculation of the indicated power in mixture scavenging engines introduces additional difficulties, the treatment is for the present limited to Diesel engines. For such engines, a theoretical air requirement L_{min} of the fuel, an air excess factor λ , and an indicated fuel consumption b_i without regard to oxygen content of exhaust gases, affords

$$P_i = 27 \frac{G_{\text{nrel}}}{\lambda b_i L_{\text{min}}} \quad (33)$$

To compute the compressor output or its corresponding mean pressure, the compressor cycle must be known. The course of the compression and expansion curves as well as the air inlet and exit control must, of course, be taken into account. Isothermic compression is probably never attainable (reference 11). With adiabatic compression, it is

$$P_{\text{gt}} = V_{\text{grel}} P_1 \frac{\kappa}{\kappa - 1} \left[(P_s/P_1)^{\frac{\kappa-1}{\kappa}} - 1 \right] \quad (34)$$

while for compressors featuring a sudden pressure rise (Roots blowers, etc.)

$$P_{\text{gt}} = V_{\text{grel}} (P_s - P_1) \quad (35)$$

At low scavenge pressures the last equation can also be employed approximately for adiabatic course of the compression curve. In all cases the total efficiency η_g must be known from which then the mean pressure corresponding to the actual blower power is obtained at

$$P_g = \frac{P_{gt}}{\eta_g} \text{ kg/m}^2 \quad \text{or} \quad p_g = \frac{P_{gt}}{10000 \eta_g} \text{ kg/cm}^2 \quad (36)$$

The termination of the example stipulates certain assumptions regarding combustion, gear losses, and compressor characteristics, which in reality must be replaced by test data. As regards the total efficiency of the blower itself, its relation to the back pressure must also be accounted for. As a general rule, the total efficiency increases with increasing pressure in blowers whose volumetric efficiency does not drop abnormally with increasing back pressure, since the leakages can be kept at a minimum by constructive safeguards. But if the leakages cannot be reduced below a certain stage, i.e., the volumetric efficiency drops rapidly as the back pressure rises (Roots blower, positive displacement type) the total efficiency drops very rapidly with increasing pressure after reaching a maximum value.

It would serve no useful purpose to include assumptions concerning the course of the blower efficiency in the example and so restrict the general validity still more. Hence we shall figure with a value of $\eta_g = 0.6$ unrelated to the back pressure. The combustion is characterized by the following values:

$L_{min} = 13.85 \text{ kg/kg}$ (gas oil), $\lambda = 1.8$, $b_1 = 0.14 \text{ kg/hp}_1\text{-h}$ gear friction at 10 percent of the indicated hp., so that $P_{er} = 0.9 p_i$. This gives the values of table 5 and, in turn, of figure 14. According to it, the highest mean pressure obtainable under the given conditions is 5.9 kg/cm^2 at $P_s = 14500 \text{ kg/m}^2$ scavenging pressure. The aspect of η_m should also be observed, which amounts to $\eta_m = 0.75$ at $P_e = 5.9 \text{ kg/cm}^2$.

Effect of Port Dimensions and High Speed

The model example has demonstrated the basic relations between scavenge air pressure and scavenging volume as well as the effects on scavenging and boosting result, i.e., on the output. In the design, the numerical influence of different port sizes must, of course, be considered in order to assume the most effective arrangement for the particular conditions. But for merely following the effect of port size in general outlines it suffices to simply change one

quantity equivalent to the time area of the ports, i.e., the engine characteristic $n D$. This has the advantage of rendering part of the data obtained from the example amenable to use. The calculation for a scavenging pressure of $P_s = 20000 \text{ kg/m}^2$ and $n D = 100, 200, \text{ and } 300$ yields (table 6 and fig. 15). In view of the fact that in the chosen arrangement the second steep pressure rise is less due to the inflowing air than to motion of the piston, i.e., compression of the charge, an examination of figure 15 and table 6 yields the following: The height of the achieved terminal pressure is in surprisingly wider limits independent of the high speed and hence of the port area itself. The steepness of the pressure rise changes in the first part of the scavenging period, and the scavenging volume G_s . Thus an increase in speed or a reduction of the scavenging ports within certain limits lowers the scavenging volume G_{sp} , while the boost volume G_{boost} remains unchanged. Hence it is possible to reproduce the conditions of optimum air input figure k without change in scavenge and boost pressure, whereby not only the obtainable power but under circumstances also the cooling effected by scavenging and in mixture scavenging engines the fuel consumption are decisive. However, it should be borne in mind that this characteristic is also dependent upon the relationship of the course of port opening and piston motion. Hence other conditions may prevail for double, auxiliary-piston and valve-scavenging engines.

Exhaust Port Dimensions

Besides the scavenging ports, the dimensions of the exhaust port can also be changed. For constant exhaust lead and constant time area of the scavenging ports this mode of action also affects the position of the ports in the control diagrams. Furthermore, since the head of cylinder pressure (in the median part of the scavenging period) corresponding to the stationary flow depends on the ratio of inlet to outlet area, this precaution acts on the whole pressure rise during scavenging, i.e., evokes more far reaching consequences than changes on the scavenging section alone.

Mixture Scavenging Engines

Here the conditions are different insofar as losses in scavenging medium are synonymous with fuel losses. If L_{min} is the theoretical air requirement of the fuel, λ ,

the ratio of air weight input to L_{min} , where λ may exceed or be less than 1, then 1 kg of scavenging medium consists of B kg fuel and $B L_{min} \lambda$ kg air, or 1 kg of scavenging medium contains

$$B = \frac{1}{1 + L_{min} \lambda} \text{ kg of fuel}$$

Hence G_s kg of scavenging medium contain $B G_s$ kg of fuel of which, however, only $B G_n = B(G_e + G_{boost})$ ever reach combustion, while $B(G_s - G_n)$ is carried off unburned.

With \bar{b}_i denoting the indicated fuel consumption obtainable in the 4-stroke engine under otherwise identical conditions, the mean indicated pressure in the 2-stroke engine follows at

$$P_i = 27 \frac{G_{nrel}}{(1 + \lambda L_{min}) \bar{b}_i} \quad (37)$$

against the true indicated fuel consumption of

$$b_i = \bar{b}_i / \frac{G_n}{G_s} \quad (38)$$

in the 2-stroke engine. Hence the effective fuel consumption is given by

$$b_e = b_i / \eta_m = \bar{b}_i / \eta_m \frac{G_n}{G_s} \quad (39)$$

For gasoline engines it amounts to approximately:

$L_{min} = 14$ kg/kg, $\lambda = 1$, $\bar{b}_i = 0.2$ kg/hp-h. The equations (37) and (39) together with the foregoing values applied to the basic diagram of the example (table 7) gives figure 17, which explains the conditions in the carburetor engine. The corresponding mean pressure was put at the same head as on the Diesel engine. According to figure 16, the fuel consumption rather than the obtainable $p_e \max$ is decisive. Hence the scavenging pressure should be so chosen that the fuel consumption remains in the central flat zone of the consumption curve. The absolute height of the consumption

in the example does not justify a negative appraisal of such engine, because the port arrangement for this purpose is expressly unfavorable. It should rather be attempted to reach comparatively small G_{sp} at great G_{boost} values i.e., to provide smaller port sections. Then the factor G_n/G_s can be kept great. At the same time, considerable residual gas remains in the cylinder, which acts as a re-action brake and increases the knock stability of the mixture. In this manner, the compression ratio can be raised and \bar{b}_i lowered. It is therefore within the realm of possibility to design mixture scavenging engines with comparatively favorable consumption figures. Engines of this type are few. The much employed V engine of the Auto-Union remains, notwithstanding the separately arranged lift-piston pumps, a crankcase engine in its operating cycle (reference 10), with symmetrical control diagram and natural aspiration.

It is obvious that mixture scavenging engines with separate blower and approximately constant scavenging pressure must be designed as supercharged engines. But then their prospects are not unfavorable, provided, of course, that a suitable fan is available. This in turn brings the design of 2-stroke alternating engine within the realm of possibility.

Pressure Curve During Scavenging with Insufficient Exhaust Lead

If the time area of the exhaust lead is too short, the pressure P_a in the cylinder during opening of the scavenging ports is higher than the pressure in the exhaust manifold P_u . This does not affect equation (11), hence the pressure can be determined as before, except that the starting point of the pressure curve is higher, as illustrated in figure 17, for the conditions of the example, $P_s = 15000$ and $P_a = 13000$ kg/m², along with the pressure curve for $P_a = P_u$. The middle and final part of the pressure curve remain the same. The lowest cylinder pressure P_n becomes substantially higher (10,800 kg/m²), and the total air input G_s drops slightly from 2.197 to 2.183 kg/m³. On the other hand, G_{boost} becomes, according to equation (29) equal to 0.266 as against 0.316 kg/m³ for $P_a = 10000$ kg/m². Precisely the most valuable part of the scavenging air - because it is not exposed to losses - is reduced.

The effect of a rise of P_u in the exhaust manifold over the atmospheric pressure is similar. As P_u or P_n increases the advantages of the unsymmetrical control diagram vested in the supercharge are more and more lost, the cycle of the engine approaches that of a common 2-stroke engine operating in proximity of higher pressure. This could be obtained equally as well in a different manner; say, by throttling the exhaust. Then it no longer involves a supercharged but a pressure-scavenging engine. These facts assume special significance in mixture-scavenging engines. Hence the design rule of ample exhaust lead and of exhaust pipes designed for minimum flow resistances and absence of deleterious exhaust vibrations.

Blower

The greatest problem in 2-stroke-engine design remains as before the blower. In stationary and ship plants of normal high speed the piston blower has proved practical and remains a favorite in spite of its comparatively high price. More recently the Roots blower (the modern design types) has also found some favor. Its fitness for this purpose is unquestionable, although its assembly with the engine does not enhance the general appearance, and the noise abatement presents difficulties, which, however, will be overcome.

But, for small high-speed engines, the blower still remains the most serious obstacle. Only the well-known Junkers with single-acting piston pump has made any headway in this respect. No rotary blowers are used except for experimental purposes. The difficulties are too well known to require repeating, except for some remarks about the demands of the supercharged engine on its blower.

Typical for such an engine is the great r.p.m. range within which it must operate and remain "elastic." The concept of elasticity may be considered as being cleared up (references 7, 13, and 14). Aside from other characteristics - in this case unimportant - this means that the moment characteristic curves (p_e) from a point located at the lowest possible r.p.m., must be descending with increasing r.p.m. at all throttle or fuel pump settings. Four-stroke Otto engines satisfy this requirement so much better as the ratio of section of carburetor air scoop to piston displacement is smaller. In Diesel engines, this characteristic depends chiefly on the fuel pump. It

usually calls for some artificial intervention, at least in the slow speed range. Although the 2-stroke-cycle Diesel engine does not rest solely on its pump characteristics, the arguments here are confined to the Otto engine (mixture-scavenging type) because it brings out these conditions more sharply.

The determination of the pressure curve and of the scavenging volume of a certain engine (= example) at different r.p.m. or different $n D$ affords the curves shown in figure 10. Plotting a straight line parallel to the ordinate axis and then the scavenging pressures corresponding to the intersection points against the $n D$, we find the connection between scavenge-air pressure and r.p.m. for constant scavenge-air volume (fig. 18), i.e., with a blower whose efficiency is independent of the r.p.m. and the back pressure. The rising boost pressure indicates an increase in G_{boost} and consequently a drop in $G_{\text{sp}} = G_s - G_{\text{boost}}$, through which k becomes smaller. The result is that the share G_e of G_{sp} left in the cylinder is comparatively greater. Hence the quantity of mixture left in the cylinder and consequently also p_i increase. Admittedly the blower output itself increases, but this can make good the rise in p_i only if accompanied by a substantial drop in the total blower efficiency. But that would be followed by very adverse fuel consumption figures. The requirement therefore will be that the blower reach its maximum efficiency at comparatively low engine speed and low back pressure and that it decrease at increasing speed with concurrent pressure rise. At the same time, the over-all efficiency throughout the whole range should be as high as possible. For a number of reasons only the rotary blower comes in question on gasoline-driven mixture-scavenging engines. The only reliable rotary blower for high speed at present (the positive displacement blowers of importance for airplane engine being disregarded in this connection) is the Roots blower in its modern design versions. The efficiency of this blower increases at unchanged back pressure with the r.p.m. At constant r.p.m. the efficiency drops very quickly with increasing back pressure. Since the last effect is certainly predominant this type appears, with proper choice of dimensions and speed, or better, of the ratio engine speed to blower speed, to satisfy the above requirements (Venediger thinks otherwise, reference 8).

Crankcase Engines

The foregoing investigations deal exclusively with 2-stroke engines with separately disposed blowers for which the scavenging-air pressure is approximately constant. In true crankcase engines (characteristics: scavenging pressure drops to around atmospheric pressure, scavenging-air volume, referred to displacement, smaller than 1) the application of unsymmetrical control diagrams seems at present useless, as no boosting is possible. But even in such engines an unsymmetrical diagram may be of advantage, because the exhaust section can be reduced without reducing the the exhaust lead and the closing of the exhaust port can be effected before or with the closing of the scavenging port. These measures can influence power and consumption. If, in addition, the control diagram is variable, improved flexibility may result under certain circumstances (reference 9). Moreover, unsymmetrical adjustable control diagrams can be obtained with very simple constructive means. The mathematical treatment of these conditions appears at present hopeless, which makes experimental elucidation of the problem that much more necessary.

CONCLUSION

The present state of engine design is characterized by the fact that in various fields of application the 4-stroke engine has reached its potential limits. Thus, for given weight or space conditions (aircraft engines, trucks) the output can in many cases be reached only by supercharging. On 4-stroke aircraft Diesel engines even this measure barely suffices to assure adequate volumetric efficiencies, which explains the limited use of such engines. For these spheres of application, the change to the 2-stroke engine is just as inevitable as it was two decades ago in the design of large engines. The very fact that a 4-stroke engine fitted with supercharger has the same structurally undesirable features as the 2-stroke engine leads to a preference for the latter. And this explains why everywhere* the development of the 2-stroke engine is pushed energetically.

*Everywhere (for instance, reference 1) and not in Germany alone, to quote an English reviewer of my book: The most patriotic Briton or Frenchman could hardly deny to German (Continued on next page)

The present article is an attempt at supplying the mathematical data for a partial problem of 2-stroke-engine design as indicated previously (reference 11). The application of the calculating method is predicted on the knowledge of the scavenging output curves (see fig. 12): establishment of these curves at different conditions is one of the most urgent necessities of 2-stroke engine design. However, even with the available data, the method can be used in the design as a check. The prediction of the pressure curve is a time-consuming task. But even if it effects only a small saving in experimental labor the task will be well paid.

Translation by J. Vanier,
National Advisory Committee
for Aeronautics.

(Continued from preceding page) engineers the credit for the greater part of the progress that has been made (the 4-stroke Diesel is meant) and it is therefore instructive to see how in Germany the 4-stroke type has received a check, and now, both openly and behind the scenes, there is feverish activity in the development of small 2-stroke Diesels (Engineering, July 24, 1936)

REFERENCES

1. Dangert, P. H.: Neuzeitliche Eisenbahnfahrzeuge in Amerika. VDI, vol. 81 (1937), S. 510.
2. List, Hans: Crankcase Scavenging of Two-Stroke-Cycle Engines. T. M. No. 516, N.A.C.A., 1929.
3. Lutz, O.: Grundsätzliche Betrachtungen über den Spülvorgang bei Zweitaktmaschinen. Forschung, Bd. 5 (1934), S. 275.
4. Lutz, O.: Untersuchungen über die Spülung von Zweitaktmotoren. Berichte Heft 1, Stuttgart, 1931.
5. Neumann, Kurt: Der Spül- und Ladevorgang bei Zweitaktmaschinen. Forschungsarbeiten, 1930, Heft 334.
6. Nusselt, W.: Die Strömung von Gasen durch Blenden. Forschung, Bd. 3 (1932), S. 11.
7. Richter, L., und Zenan, J.: Belastung, Fahrgeschwindigkeit und Brennstoffverbrauch. ATZ, Jahrgang 38, Heft 13, July 10, 1935, S. 327-30.
8. Venediger, Herbert J.: Untersuchungen an schnellaufenden Auflade-Drehkolbenverdichtern. ATZ, Bd. 36, Heft 23, Dec. 10, 1933, S. 579-83, and Heft 24, Dec. 25, 1933, S. 619-22.
9. Venediger, H. J.: Grundsätzliche Betrachtungen zum Zweitaktverfahren. ATZ, Bd. 39, Heft 11, June 10, 1936, S. 273-80.
10. Venediger, H. J.: Stand und Entwicklung der Zweitaktmotoren für Kraftfahrzeuge. VDI, Bd. 81 (1937), S. 187.
11. Zenan, J.: Zweitakt Dieselmotoren. Vienna, 1935. (Julius Springer).
12. Zenan, J.: Verdichtungsverluste bei kleineren Zweitakt Dieselmotoren. Forschung, Bd. 6, Heft 3, May-June, 1935, S. 129-38.
13. Zenan, J.: Die natürlichen Kennlinien von Vergasermotoren. ATZ, Bd. 38, Heft 17, Sept. 10, 1935, S. 426-28.

14. Zeman, J.: Der Fahrzeugdieselmotor. Petroleum, Bd. 33 (1937), No. 6, S. 1.

List, H., and Niedermayer, E.: Versuche an der Zweitakt-dieselmachine. Forschung, Bd. 8, Heft 6, Nov./Dec. 1937, S. 265-78. (This article was published after completion of report.)

Table II

Part no.	1	2	3	4	5	6	7	8	9	10										
$\Delta \alpha$	0,0818	0,0818	0,1636	0,1636	0,1636	0,1636	0,1636	0,1636	0,0818	0,0818										
$\frac{s-y}{s} + 0,06$	1,041	1,05	1,057	1,059	1,051	1,032	1,005	0,965	0,930	0,904										
$l_{s,rel}$	0,022	0,07	0,138	0,169	0,161	0,142	0,115	0,075	0,040	0,014										
$l_{s,rel}$	0,121	0,130	0,137	0,139	0,131	0,113	0,085	0,045	0,010	0										
$l'_{s,rel}$	0,0211	0,0666	0,1305	0,1595	0,1532	0,1376	0,1145	0,0777	0,043	0,0155										
$l'_{s,rel}$	0,1182	0,1238	0,1296	0,1312	0,1246	0,1095	0,0845	0,0466	0,01075	0										
P assumed	10000	10100	10300	10400	11300	11400	12400	12200	12500	12400	12500	12700	12800	12900	13300	13400	14000	14100	14800	14700
ψ_s	1,397	1,387	1,364	1,351	1,239	1,225	1,053	1,091	1,033	1,053	1,033	0,994	0,974	0,954	0,887	0,845	0,683	0,650	0,258	0,342
ψ_s	0	0,216	0,435	0,511	0,873	0,899	1,108	1,072	1,125	1,108	1,125	1,158	1,173	1,188	1,243	1,254	1,313	1,322		
$A \psi_s l'_{s,rel}$	6040	5960	18620	18440	33300	32800	34450	35700	32450	33100	29150	28050	22870	22400	13800	13460	6200	5730	820	1086
$B P \psi_s l'_{s,rel}$	0	4840	10600	12570	24410	25350	34400	32750	33450	32700	29400	30750	24250	24750	14700	14950	3775	3830		
Difference	6040	1150	8020	5870	8890	7450	50	2950	-1000	400	-250	-2700	-1380	-2350	-900	-1500	2425	1900	820	1086
$\Delta y/s$	-0,01	-0,007	-0,0065	+0,0035	+0,012	+0,025	+0,032	+0,046	+0,024	+0,0275										
$\left(\frac{\Delta y}{s}\right)' \cdot \frac{1}{\Delta \alpha}$	-0,11075	-0,0815	-0,0376	+0,0202	+0,0698	+0,148	+0,1946	+0,291	+0,315	+0,372										
$1,4 P \left(\frac{\Delta y}{s}\right)' \cdot \frac{1}{\Delta \alpha}$	-1550	-1565	-1175	-1185	-594	-600	+350	+345	+1220	+1210	+2590	+2630	+3490	+3515	+5420	+5480	+6170	+6220	+7710	+7650
$\frac{\Delta P}{\Delta \alpha}$	4490	-415	6845	4685	8290	6850	400	3295	220	1610	2340	-70	2110	1165	4520	3960	8595	8120	8530	8736
ψ_s	1,392	1,358	1,239	1,090	1,04	1,013	0,964	0,86	0,668	0,345										
$\Delta G_{s,rel}$	0,03645	0,1133	0,4080	0,44	0,40	0,343	0,264	0,1538	0,0318	0,00575										
$G_{s,rel}$	2,197 kg/m ²																			

Table IV

P_s kg/m ²	11000	13000	15000	20000	
v_{sp} m ³ /kg	0,925	0,966	1,005	1,093	
$k = G_{sp,rel} \cdot v_s$	0,748	1,396	1,892	3,1	
Rest in Cylinder	Parts of volume of V_s (from Fig 12)	0,50	0,76	0,81	0,82
	$G_{s,rel}$	0,481	0,7	0,718	0,668

Table III

P_s kg/m ²	11000	13000	15000	20000
T_s °K	316	330	343	373
v_s m ³ /kg	0,842	0,743	0,67	0,546
$A = 92,3 \zeta_s \frac{\sqrt{T_s}}{nD} P_s$	144500	174300	205000	285000
$B = 92,3 \zeta_s \frac{\sqrt{T_{max}}}{nD}$	19,1	19,1	19,1	19,1
$\frac{120 \zeta_s}{\pi^2 nD} \sqrt{P_s/v_s}$	11,4	12,86	14,58	18,62
P_v kg/m ²	11500	13350	15050	19400
$G_{s,rel}$ kg/m ²	0,876	1,642	2,2	3,28
$G_{s,rel}$ kg/m ²	0,068	0,1907	0,316	0,547

Table V

P_s kg/m ²	11000	13000	15000	20000
p_1 kg/cm ²	4,32	6,95	8,05	9,4
$P_{er} = 0,9 p_1$ kg/cm ²	3,88	6,25	7,25	8,45
$V_{er,rel}$	0,74	1,39	1,86	2,77
P_{st} kg/m ²	710	3780	8000	21300
p_c kg/cm ²	0,118	0,63	1,33	3,6

Table VI

P_s kg/m ²	20000		
nD m/min	100	200	300
P_v kg/m ²	19350	19220	19000
$G_{s,rel}$ kg/m ²	3,28	1,6918	1,1517

Table VII

P_s kg/m ²	11000	13000	15000	20000
$G_{s,rel}$ kg/m ²	0,876	1,642	2,2	3,28
$G_{s,rel}$ kg/m ²	0,547	0,8967	1,034	1,215
G_s/G_s	0,625	0,547	0,47	0,37
p_1 kg/cm ²	5,01	8,07	9,3	10,95
$P_{er} = 0,9 p_1$ kg/cm ²	4,51	7,26	8,37	9,86
p_c kg/cm ²	0,118	0,63	1,33	3,6
η_m	0,877	0,822	0,757	0,572
b_s kg/hp-h	0,365	0,423	0,562	0,945

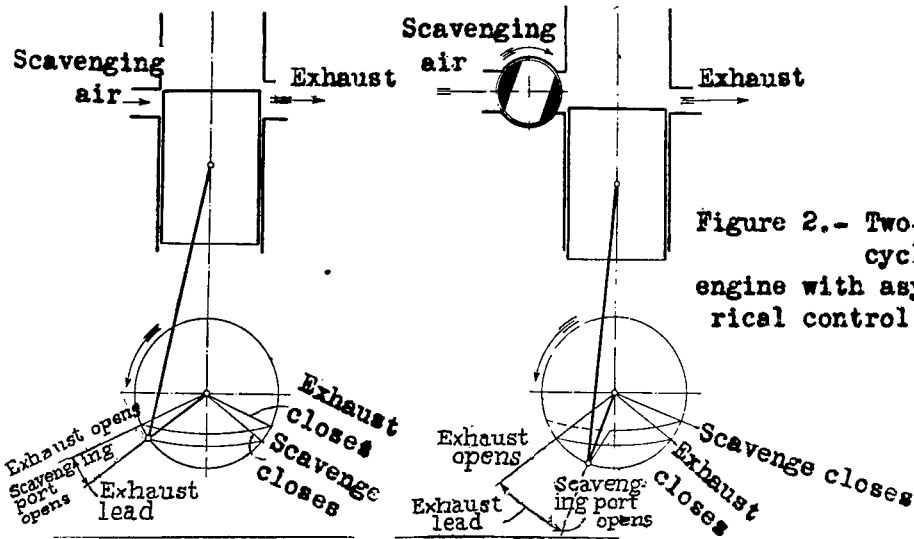

Figure 1.- Two-stroke cycle engine with symmetrical control diagram.

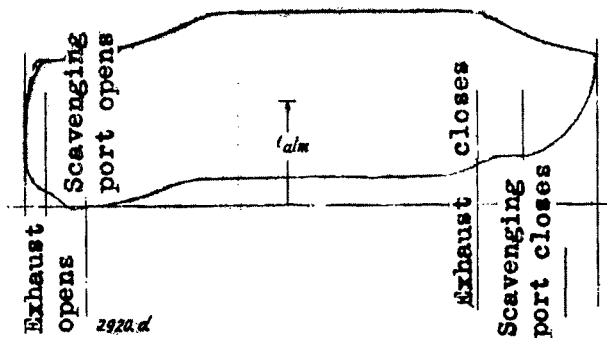
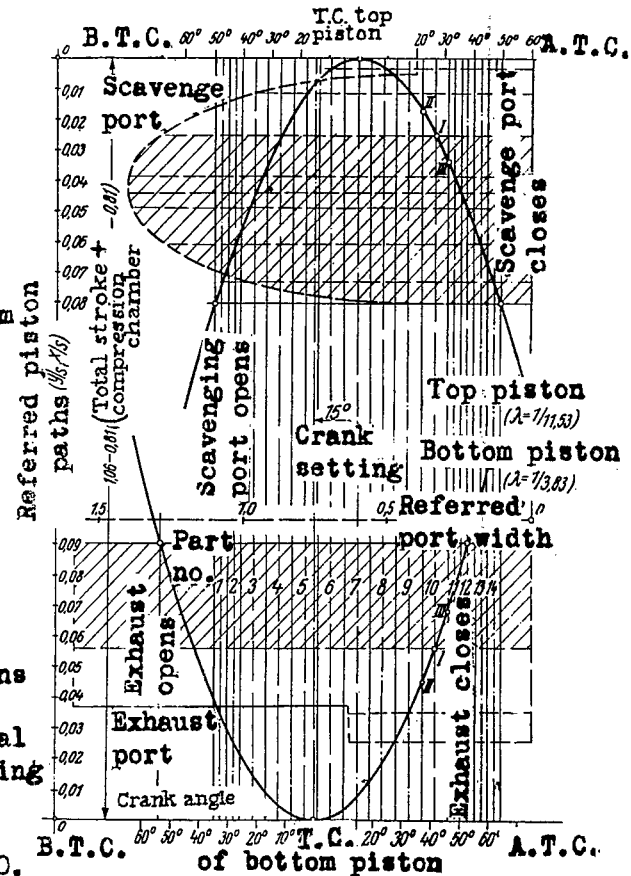

Figure 4.- Indicator card of the scavenging cycle of the Junkers engine - experimental values: $n = 560$, volume of air indicated by blower: $1:74 \text{ m}^3/\text{min.}$, room temperature 18°C , 735mm/Hg .

Figure 2.- Two-stroke engine with asymmetrical control diagram

Figure 3.- Piston path curves and referred part dimensions of the Junkers engine, defining the geometrical principles for evaluating eq. 15. The following relate to table 1. To illustrate: part no. 10. The shaded areas give $f_s \text{ rel} (= 0.06751)$ and $f_a \text{ rel} (= 0.0543)$, i.e. the values of line 4 and 5; the length I-I + $0.81 (= 0.979)$ is

equal to $\frac{s - x - y}{s} + 0.06$, i.e. the value of line 3. Hence $f_s \text{ rel} = 0.06751/0.979 = 0.069$ and $f_a \text{ rel} = 0.0543/0.979 = 0.0555$ and are the values of lines 6 and 7. In addition, the difference of II - III = $0.041 = (\Delta y - \Delta x)/s$, line 14, gives $0.041/0.979 + [(\Delta y - \Delta x)/s]$, which, multiplied by $1/\Delta a$ gives the value of line 15.



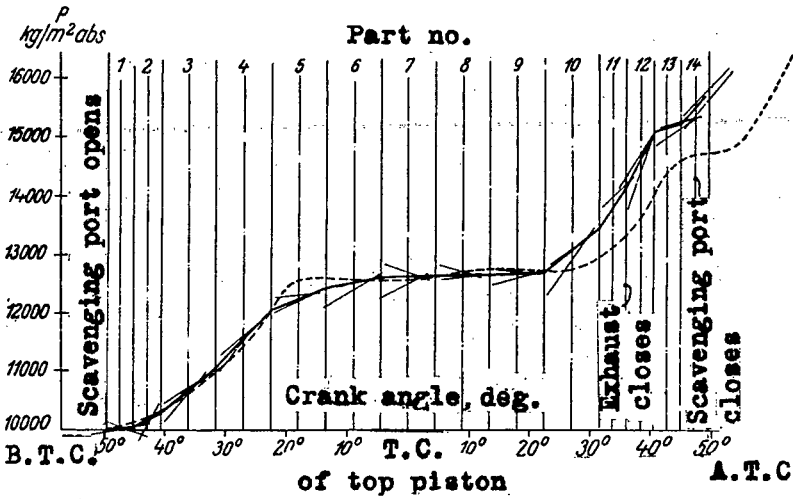

Figure 5.- Pressure variation during scavenging cycle in the Junkers engine. Solid line; computed; dotted line; indicated, as obtained by replotting fig. 4.

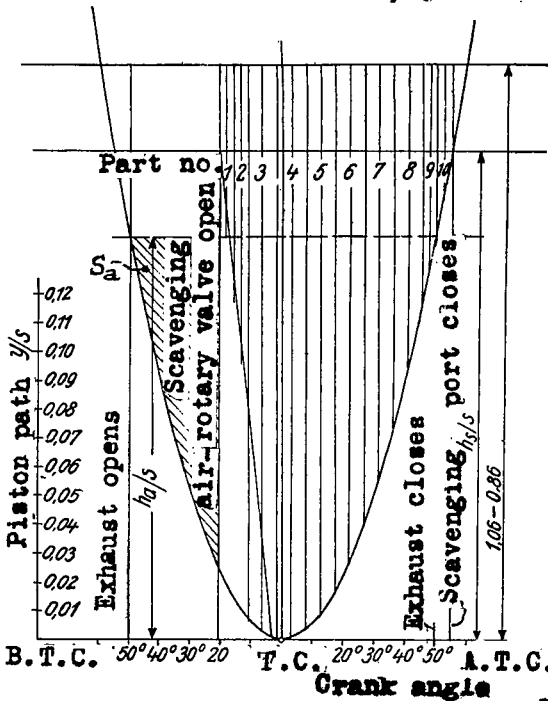

Figure 6.- Piston path and part height for illustrative engine. The evaluation gives, as in figure 3, the lines 3,4,5,6, 7,14, and 15 of table 2.

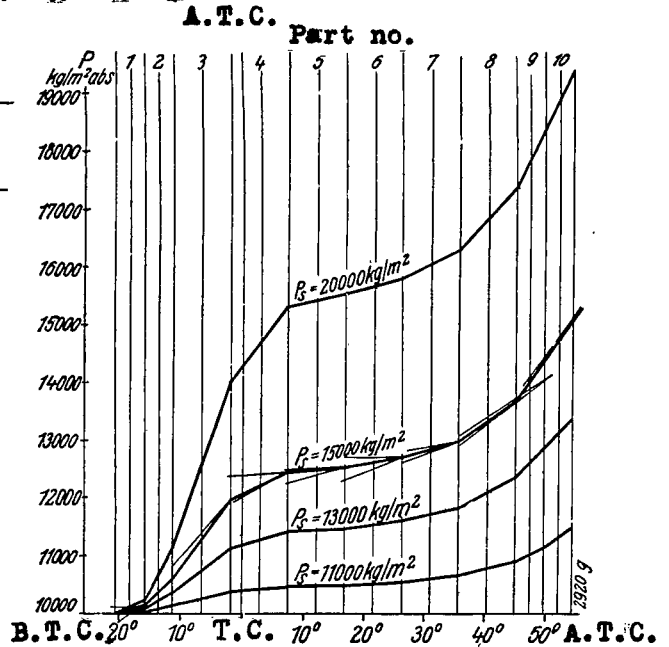

Figure 7.- Pressure variation during scavenging.

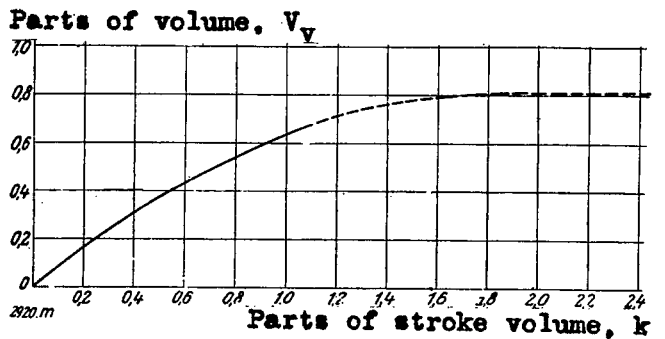

Figure 12.- Scavenging results for loop scavenging (adopted and extended according to reference 2)

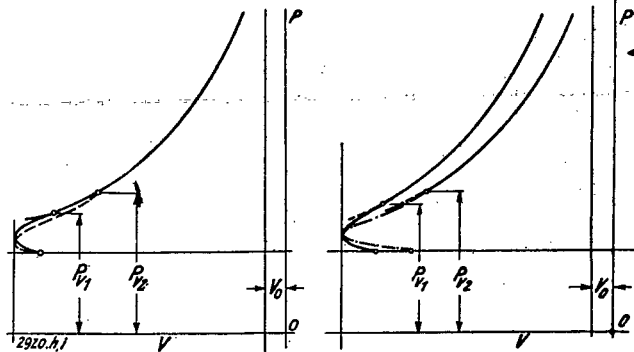

Figure 8.- Despite the difference in obtained boost pressure both scavengings are equivalent, since they pass in the same compression curve, i.e. the charging volume is the same in both cases.

Figure 9.- Despite the fact that P_{v1} is smaller than P_{v2} the charging result in the first case is better, since the pressure line empties in a higher located pressure line, the charging volume is better than in the second case.

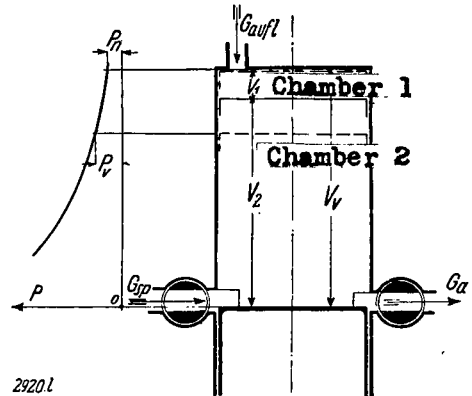

Figure 11.- Two-stroke cycle engine with scavenging and boosting separated in time and space.

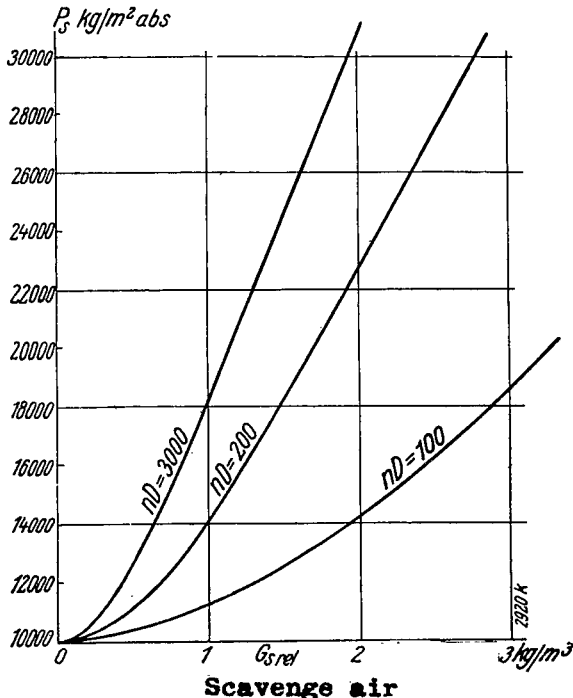

Figure 10.- Scavenging pressure against scavenging volume for different engine characteristics.

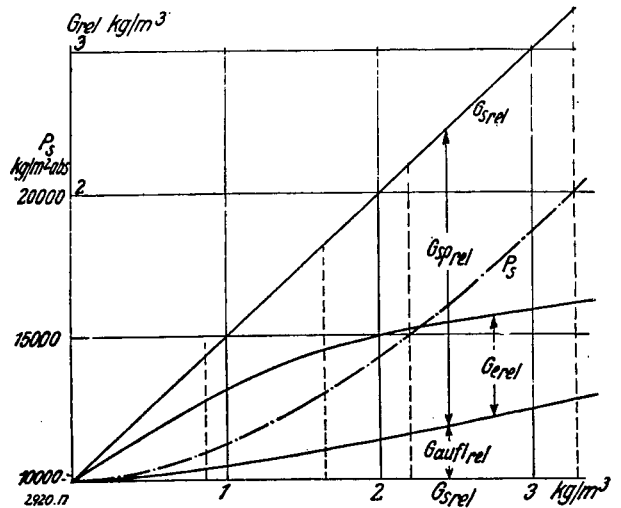

Figure 13.- Scavenging result. Air volume left in cylinder against scavenging air input.

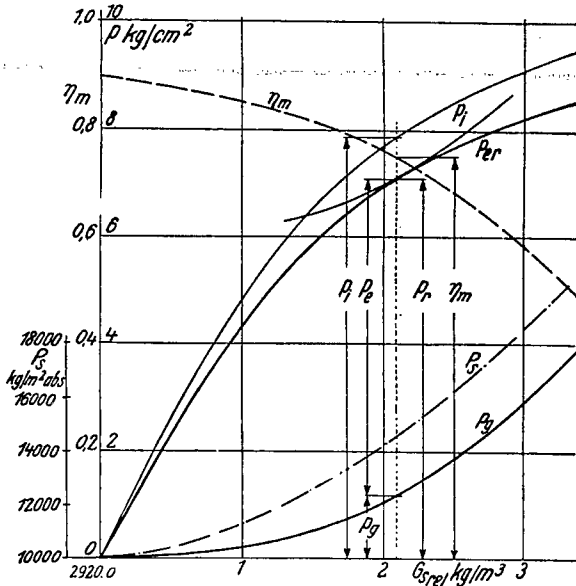

Figure 14.-Indicated and mean effective pressure, mechanical efficiency against amount of scavenging air in Diesel engines. The maximum P_e can be found by parallel shifting of P_g line.

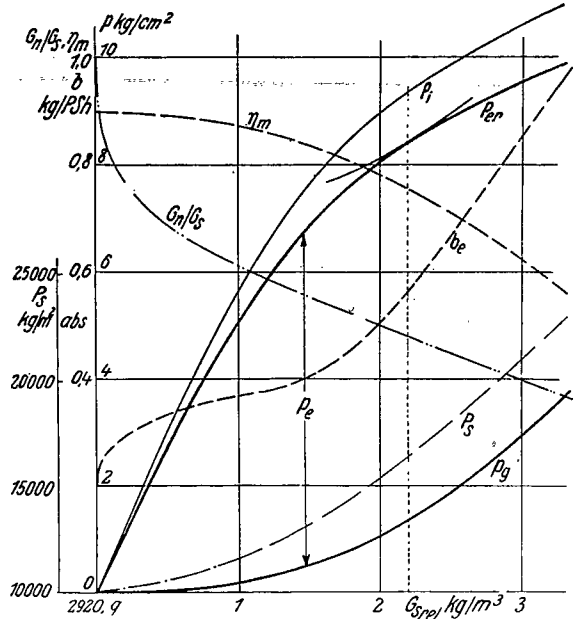

Figure 16.- Indicated and mean effective pressure, mechanical efficiency, fuel consumption against amount of scavenging air in mixture scavenging engines.

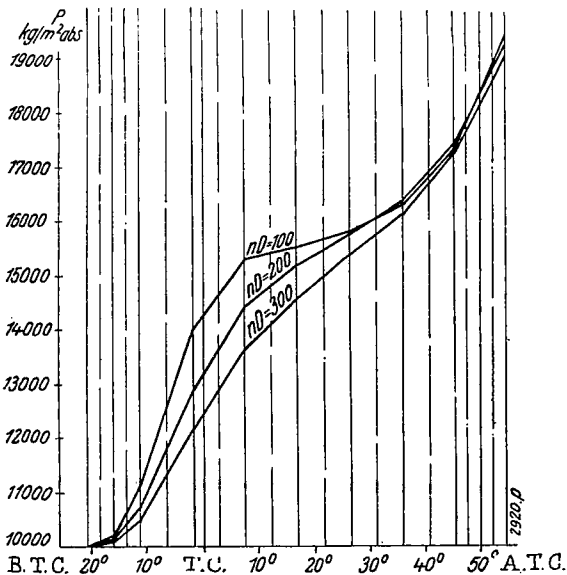

Figure 15.- Pressure variation during scavenging at $P_s = 20,000 \text{ kg/m}^2$ and different nD .

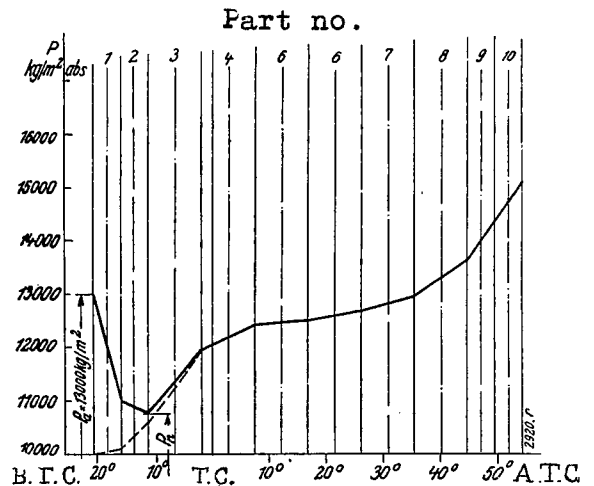

Figure 17.- Pressure variation during scavenging, for $P_a = 13,000 \text{ kg./m}^2$.

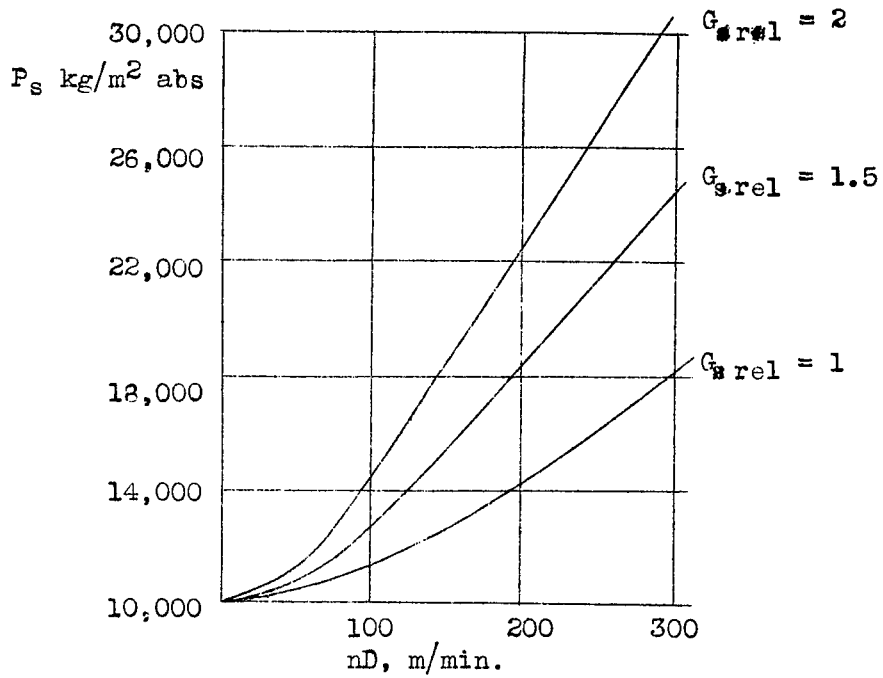

Figure 18.- Rise in scavenging pressure with the r.p.m. and constant scavenge air volume.

NASA Technical Library



3 1176 01440 6749