

NACA TM 564

TECHNICAL MEMORANDUMS
NATIONAL ADVISORY COMMITTEE FOR AERONAUTICS

No. 564

RECENT TESTS OF TAILLESS AIRPLANES

By Alexander Lippisch

From L'Aérophile, February 1-15, 1930

REPRODUCED BY
NATIONAL TECHNICAL
INFORMATION SERVICE
U.S. DEPARTMENT OF COMMERCE
SPRINGFIELD, VA 22161

Washington
May, 1930

NATIONAL ADVISORY COMMITTEE FOR AERONAUTICS.

TECHNICAL MEMORANDUM NO. 564.

RECENT TESTS OF TAILLESS AIRPLANES.*

By Alexander Lippisch.

The history of airplane construction is to-day at a decisive turning point. After the diversity of types of construction during the first ten years of aviation, the rapid development of this industry has led to a general standardization. These types met the demands made of them, so that it was not necessary to introduce notable innovations. Since then, the field of aviation has been extraordinarily enlarged. The airplane has now become a means of transportation which cannot be disregarded.

It is evident that, with an augmented field of application, efficiency should be improved and that subsequent development is only possible by conforming to these conditions. To-day these imperfections of standardized construction represent the real obstacle to the development of aviation. It is not unusual to hear it said that the airplane will always be surpassed in range of application by other means of locomotion. To prove the contrary, one has first to note ways in which airplanes could be improved. Three of these ways are:

- 1. To diminish the weight of construction by studying the structure and improving the materials;

*"Les nouveaux essais d'avions sans queue." From L'Aérophile, February 1-15, 1930, pp. 35-39.

2. To improve the power plant, diminish the specific fuel consumption and improve the propeller efficiency;

3. To modify the aerodynamic forms so as to lessen the structural drag, simplify the construction, and improve the fineness ratio (L/D).

As regards the first point, constant progress has been made during recent years. The same applies to the second point. However, a greater propeller efficiency is possible only with a new method of mounting the engine bed. That is why the third point constitutes, so to speak, the key to all the other possibilities of improvement, which cannot be applied entirely without considerably modifying the existing types of construction. It is surprising that so few improvements have been made in this connection during recent years.

We must seek first that form of airplane most nearly approaching the "ideal airplane." This ideal airplane would be one from which would be eliminated all accessories not actually necessary for flight. It would then be composed of only one wing carrying the loads, possessing a power plant and having the necessary controls.

It is a question at present therefore of making tests with airplanes whose wing form permits the elimination of separate tail surfaces; of ascertaining whether this wing presents disadvantages as compared with the standard type; and, finally, of

seeking ways to eliminate such disadvantages.

Some of these forms of construction, generally designated by the term "tailless," have already been practically tested. In regard to these, it is principally problems of construction which have brought failure to designs that promised much.

For such an airplane whose wing is heavier (due to unfavorable distribution of the stresses) than a normal wing of the same characteristics with tail and fuselage, its particular advantages would hardly count.

Suppose, for example, we work out a design and wish to make it full-scale. Will it meet our expectations? We might, as is generally done, determine the aerodynamic characteristics of the new airplane in a wind tunnel. This airplane may be deceptive, however, as to its performance, because the model tests give only an approximation of its aerodynamic characteristics and stability. The effect of outside disturbances during flight cannot be determined so easily, or at least necessitates long and costly experiments. It would be well then, besides testing in a wind tunnel, to verify the aerodynamic stability with the aid of reduced-size models in free flight and thus test the value of the design by both theory and practice.

That is why the author at the Institute of Research of the Rhön-Rossiten Society, began by determining the manner in which the models behaved. In order to be able to determine the flight characteristics of airplanes, it was necessary to choose their

dimensions and specific loads so that the laws of aerodynamic and mechanical analogy could be applied. The Reynolds Numbers must be above the critical domain, and the wing loading must conform to the scale.

These requirements call for airplanes of about 4 meters (13 feet) wing span, carrying 10 to 15 kg/m² (2 to 3 lb./sq.ft.). Different tailless models, as well as the "Canard" (duck) type, were thus tested. Model 4 (Fig. 1) shows the primitive form of the present "Storch" (stork) type of construction. In the sketch the model shows a wing with sweepback and normal ailerons which serve also as elevators. Beneath the tips of the wings, placed obliquely and in front, are the rudders.

Contrary to all the preceding types of wing construction with such a sweepback, stability was here obtained by the inversion of the profile. It is known that such a wing can be stable in flight only when the lift diminishes from the middle toward the tips. Formerly this progressive diminution of lift was obtained by the simultaneous action of the wind on the two surfaces of the wing ("Dunne" type) and the difference in lift was not held essential. In this manner, however, with the use of normal profiles and their usual displacement of the center of pressure at different angles of attack, considerable moments of torsion are produced, necessitating reinforcement. On the contrary, if the curvature of the wing profile, instead of its angle of attack, is modified, smaller moments of torsion are ob-

tained with the excessive sweepback of the wing than with a normal airplane wing. In the "Storch" with an ordinary profile, the camber and thickness diminish in such a manner that the profile of the wing tip is flat and inverted.

It is equally possible, however, to make wings tailless without sweepback by equipping straight wings with profiles having a fixed center of pressure. Such an arrangement allows a simpler construction, but occasions certain parasitic vertical motions. A model of this type was tested and showed that the theoretical objections to this arrangement were unfounded. The airplane shown in Figure 2 is stable because the center of gravity is below the center of pressure. The whole system represents an ordinary pendulum. Since its moments of inertia and its parasitic motions are small, its flight does not differ materially from that of normal airplanes. It can be stated, on the contrary, that the stability is particularly good. The different models were tested in a large number of flights. Launching was effected by means of an elastic cable and a track. In this way one can attain, over flat ground, a sufficient length of flight to test the effectiveness of different positions of the rudder. The launching track is shown in Figure 3. All the rudders could be fixed mechanically in definite positions, in order to determine their action in flight.

After the main problems were solved by these tests, construction was begun on a glider like the first model. Some experi-

ments in the wind tunnel were then made. It was found that the profiles, as designed, were unfavorable for the maximum lift. They were accordingly modified to approach the Joukowsky type. The models were tested with the fuselage and it was ascertained, on the basis of the polars, that, with an aspect ratio of 8, excellent fineness ratios L/D were obtained. The profiles tested, as well as the polars, are shown in Figure 4. Since the estimates allowed for the presence of the fuselage, no additional calculations had to be made for the structural drag of full-scale airplanes.

An airplane for one pilot was then built like the second model. It had at first a dihedral wing with rudders extending downward, but, since this arrangement gave poor maneuverability, the dihedral was completely eliminated and the lateral rudders were transferred to the upper surface of the wing. Figure 5 shows the diagram of the elevators and ailerons. A large number of gliding and soaring flights were made with the type shown in Figure 6, and these flights gave satisfactory results. They led to a modification of the fuselage. Furthermore, the rudders were enlarged and divided and the "elevator-aileron" were modified in such a way as to make their axes perpendicular to the direction of flight. Thus the glider arrived at the form shown in Figure 7. It then gave absolute satisfaction as regards stability, so that the action of the controls and all the special properties of tailless airplanes could

be studied in numerous gliding and soaring flights.

These flights, which took place during the summer of 1929, gave the following results. In horizontal flight, the elevator was more sensitive than that of a normal airplane. The movements were shorter and by jerks, but this sensitiveness was not disagreeable because it facilitated the transition from one attitude of flight to another. It was likewise possible to render the glider more stable in this respect by slight modifications of the profile. If the controls were handled as for a vertical landing, a stable attitude of flight was obtained without any tendency to side slip or assume another attitude of flight. The action of the rudders was conserved in spite of a very reduced speed, so that a change of course could be made under these conditions.

The setting of the elevator by degrees and locking it did not cause loss of stability. The glider ascended and descended vertically, until normal flight was attained while continuing to fly at a large angle of attack. Here also the extraordinary effectiveness of the controls was especially evident.

On the one hand the most abrupt turns were made in an ir-approachable manner. A side slip was then tried very successfully. On the other hand, a reduction in the length of the glide was also attained. An effective braking action was obtained by deflecting the two lateral rudders which could be operated independently of each other. The glider, which generally descends

very gradually, can in this manner make a more nearly vertical descent. Figure 8 shows the operation of the rudders.

The results obtained with the glider being absolutely satisfactory, its reconstruction as a powered airplane was begun in the fall of 1929. The engine was chosen as low-powered as possible - 500 cm³ (30.5 cu.in.) DKW air-cooled engine. Its power at the level of the Wasserkuppe - 900 to 1000 m (2953 to 3280 ft.) reached 7 to 9 hp. This is why the usual glider-launching device was adopted.

The engine placed behind the wing necessitated moving the pilot's seat forward. The fuselage was then reconstructed and the lateral rudders replaced by stronger ones. Figure 9 shows this airplane. A special cooling system was installed with a fan and air ducts. In the course of the tests the cooling system was still further improved and the fuel tank installed in the wing. The airplane was flown first as a glider with the propeller locked and then with the engine running. The airplane demonstrated its complete aptitude for flight although, due to the excessive dimensions of the propeller, the difficulty of cooling necessitated reducing the revolutions to 2800 r.p.m. (the maximum power corresponding to 3300 r.p.m.). Under these conditions, however, the climbing and speed performances of the airplane were very satisfactory. The speed reached 125 km (78 mi.) per hour at an altitude of 1000 m (3280 ft.). These first tests show that it should be possible to improve greatly the

performances of tailless airplanes. The airplane was exhibited in flight to a large number of German and foreign specialists. It was perfectly and successfully piloted during all these demonstrations by Groenhoff.

The tailless airplane is of special interest in every case where it is desired to improve the economy and maximum speed, that is to say, in particular, for commercial airplanes used on long flights. This improvement of performance should level the barriers which still prevent the airplane from finding its use in domains where it should render valuable service in economic and social life.

Characteristics of the "Storch" Airplane

Span	12.37 m	40.58 ft.
Length	3.8 "	12.47 "
Height	2.0 "	6.56 "
Chord at center of wing	1.89 "	6.20 "
Chord at end of wing	1.17 "	3.84 "
Wing area	18.5 m ²	199.13 sq.ft.
Area of elevator-aileron, each	0.93 "	10.01 "
Area of rudders with fins, each	0.80 "	8.61 "
Engine, DKW, air-cooled	7-9 hp	
Propeller, RRG	1.24/0.6 m H	4.07/1.97 ft.p.
Weight, empty	170 kg	374.8 lb.
Load carried	80 "	176.4 "

Weight in flight	250.0 kg	551.2 lb.
Wing loading	13.5 kg/m ²	2.77 lb./sq.ft.
Power loading	30.0 kg/hp	65.2 lb./hp
Power per unit area	0.45 hp/m ²	.042 hp/sq.ft.

Translation by
National Advisory Committee
for Aeronautics.

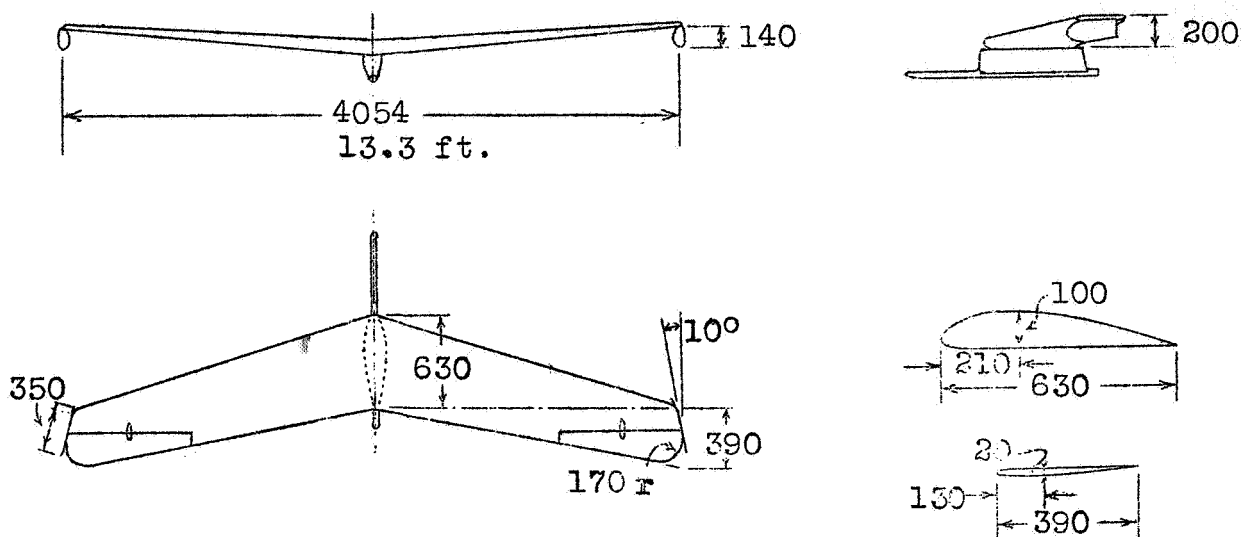

Fig. 1 Model No.4 Wing area 2 m^2 Weight 14 kg.
 21.53 sq.ft. 30.86 lb.

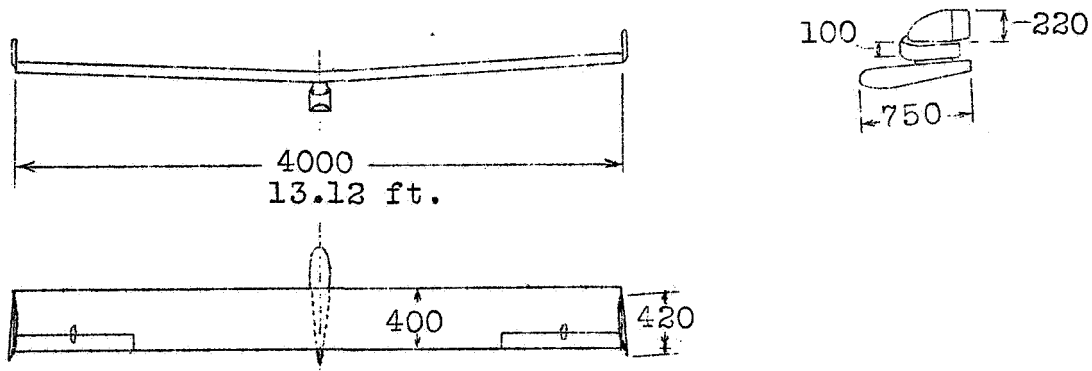

Fig. 2 Model No.6 Wing area 1.6 m^2 Weight 12 kg.
 17.22 sq.ft. 26.46 lb.

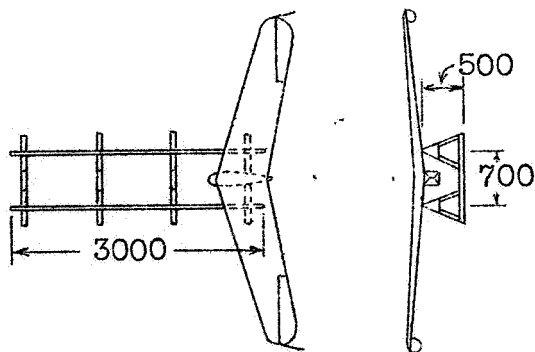

Fig. 3 Starting track for test models

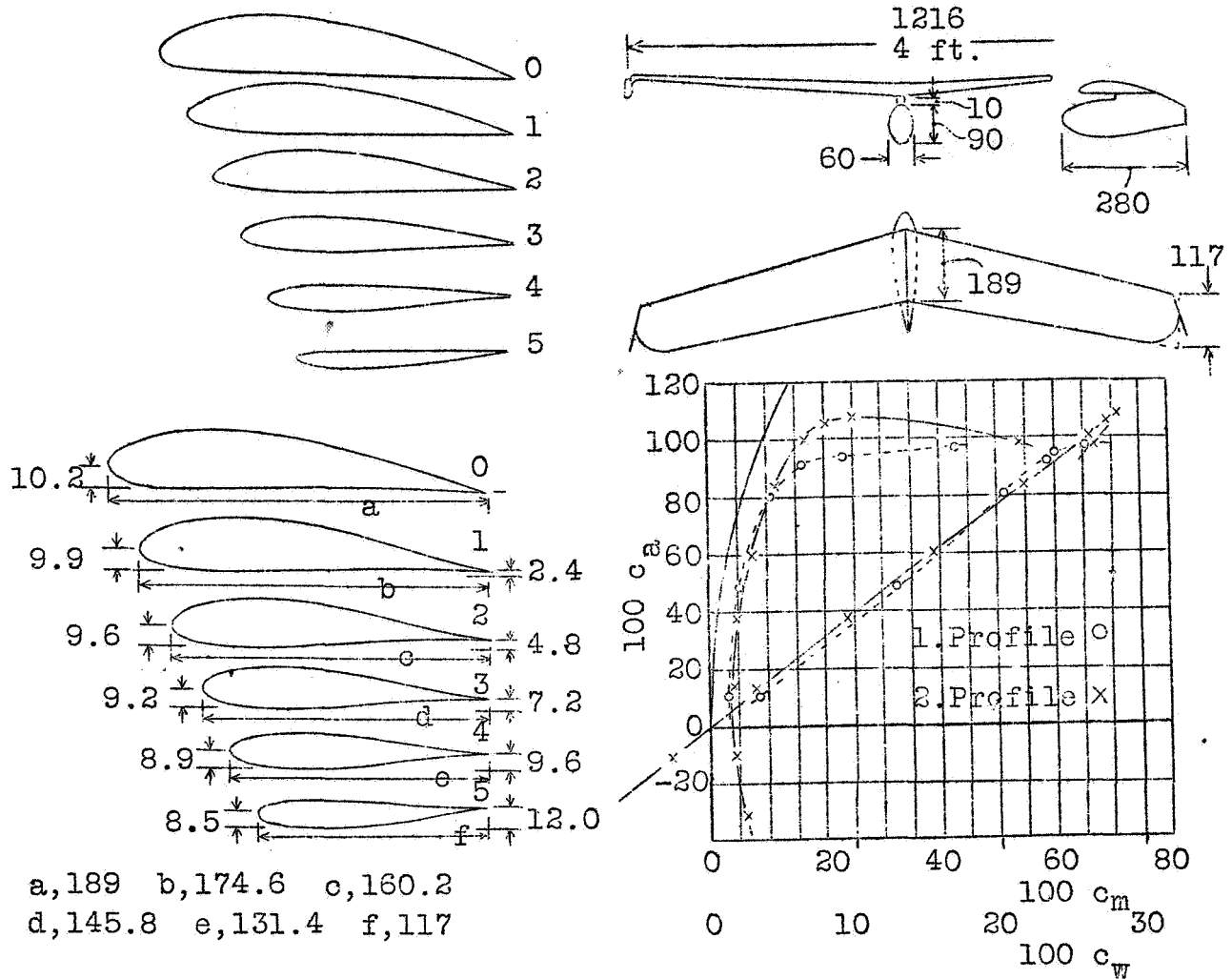

Fig. 4 Results of tests with models in Göttingen laboratory.

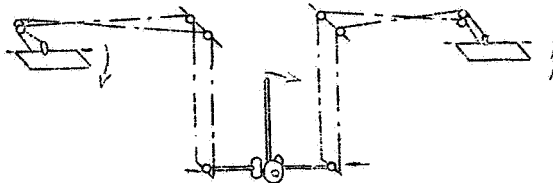
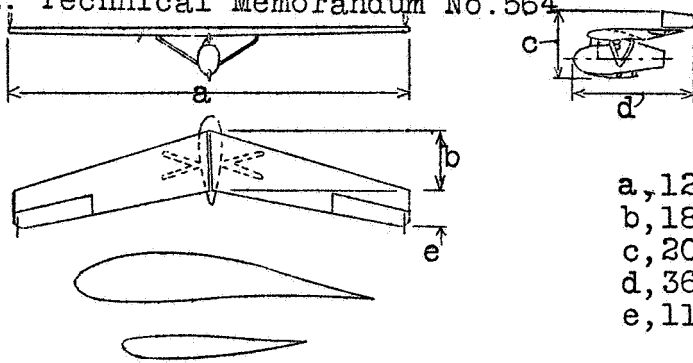

Fig. 5 Aileron and elevator controls of tailless glider.



- a, 12200 (40 ft.)
- b, 1890
- c, 2020
- d, 3655
- e, 1170

Fig. 6 Test glider model "Storch" first form, 1927.

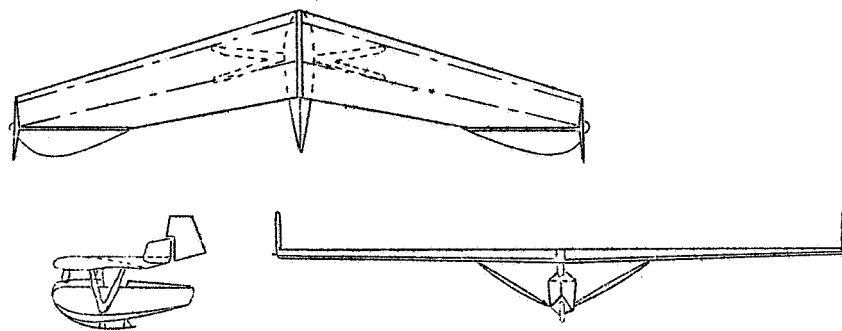

Fig. 7 "Storch" glider.

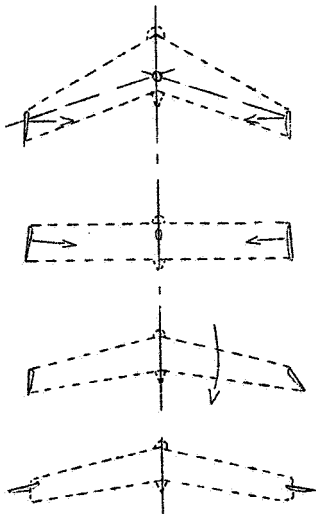

Fig. 8 Operation of lateral rudders.

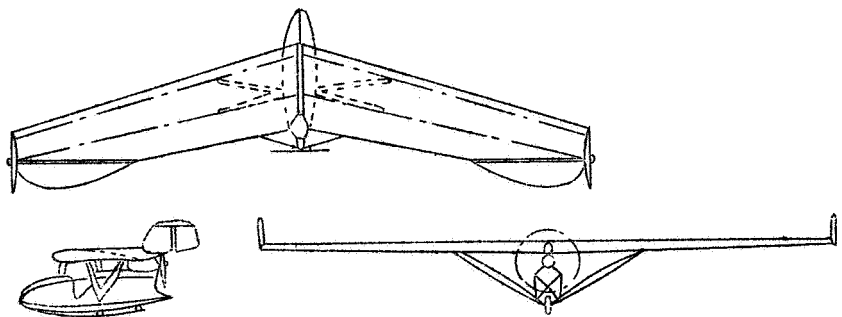

Fig. 9 Light tailless airplane "Storch" equipped with DKW 7-9 hp engine.