

1N-07  
P-83

NASA Contractor Report 189203

# Advanced Control for Airbreathing Engines

Volume 1

## Pratt & Whitney

J.A. Ralph  
*United Technologies, Inc.*  
*Pratt & Whitney*  
*West Palm Beach, Florida*

July 1993

Prepared for  
Lewis Research Center  
Under Contract NAS3-25952



(NASA-CR-189203) ADVANCED CONTROL  
FOR AIRBREATHING ENGINES, VOLUME 1:  
PRATT AND WHITNEY (United  
Technologies Corp.) 83 p

N94-12270

Unclas

G3/07 0176731



## ADVANCED CONTROL FOR AIRBREATHING ENGINES

Final Report for Phases I and II Work

Contract Periods

October 1989 - April 1990

October 1990 - April 1991

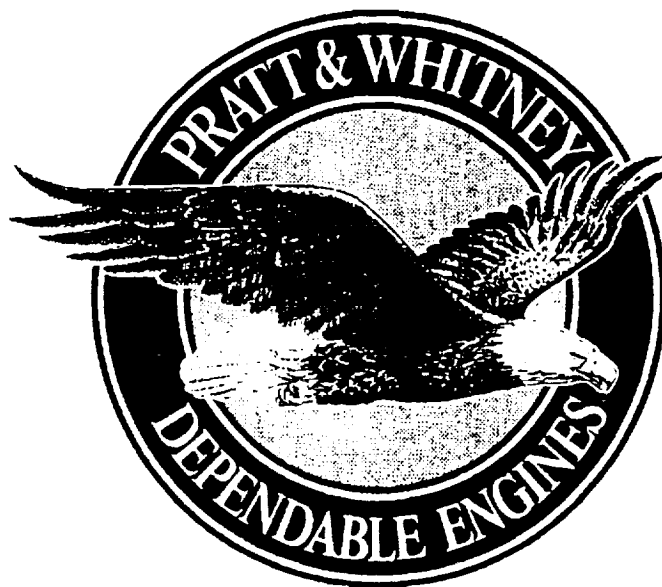

PREPARED FOR  
NATIONAL AERONAUTICS AND SPACE ADMINISTRATION  
Lewis Research Center  
Under Contracts  
NAS3-25117, Task 15  
NAS-25952, Task 4

*Jon A. Ralph*  
J. A. RALPH



P. O. Box 109600  
West Palm Beach, FL 33410-9600  
407/796-3051

Government Engine Business

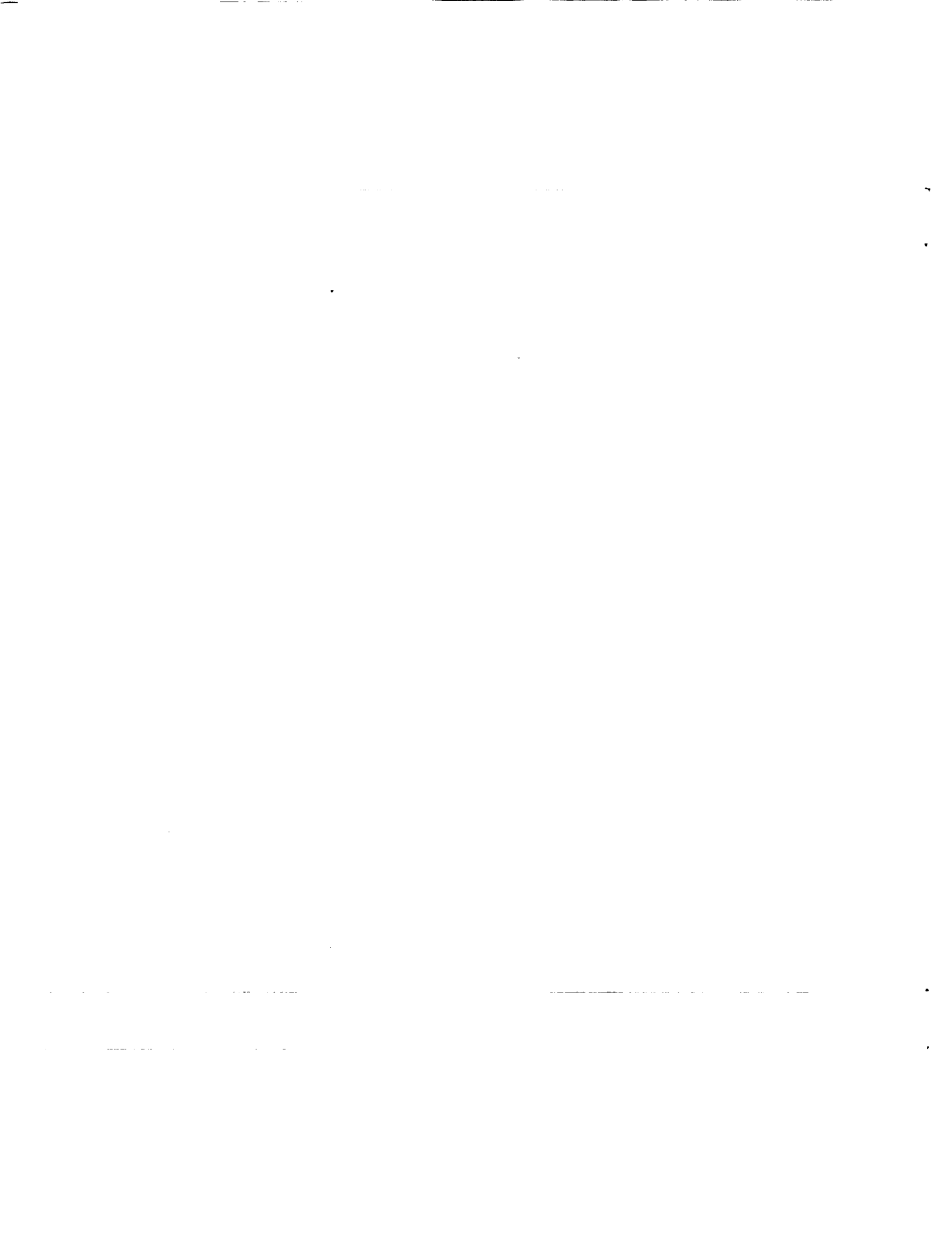

TABLE OF CONTENTS

Forward.....	ii
Table of Contents.....	i
Summary.....	1
Introduction.....	2
Main Text.....	3
Phase I - Preliminary Evaluation.....	3
Subtask 1 - Establish Control Concepts.....	3
Subtask 2 - Establish Basis of Comparison.....	4
Engine/Aircraft Selections.....	4
Figures of Merit.....	5
Preliminary Screening.....	5
Design Analysis.....	6
Concept Trade Factors and Weights.....	7
Cycle Analysis.....	7
Normalizing Factors.....	8
Phase I Summary.....	11
Phase II - Detailed Evaluation.....	12
Life Cycle Costs.....	13
Control System Component Weight Impacts.....	14
Cycle Impacts on Engine Weights.....	15
Compression System Component Weights.....	15
HIDEC/PSC Control System.....	15
Figures of Merit.....	16
Normalizing Schedule for FOMs.....	16
Phase II Evaluation.....	17
Trade Factors and Figures of Merit for ASC.....	17
Trade Factors and Figures of Merit for SSC.....	18
Trade Factors and Figures of Merit for PSC.....	18
Trade Factors and Figures of Merit for IEC.....	19
Detailed Cycle Analysis.....	20
Summary of Figures of Merit.....	20
Recommendations for Further Development.....	21
Summary.....	22
Appendix A, Phase I Descriptions and Diagrams.....	23
Appendix B, Phase II Descriptions and Diagrams.....	24

FORWARD

This report documents the work completed under Phase I (NAS3-25117, Task 15 of the Unique Propulsion Concepts) and Phase II (NAS3-25952, Task 4 of the Aero-propulsion Technology). The Phase I task purpose was to complete a "preliminary" evaluation of candidate control concepts and rank them in order of potential benefit toward engine operability and performance. "Detailed" evaluations of the top four ranked Phase I concepts were done in Phase II.

The bulk of the task was performed within the Propulsion Systems Analysis Department of the Government Engine & Space Propulsion Division of Pratt & Whitney. Experts within both government and commercial engine groups were consulted and their ideas were used to generate potential concepts, descriptions and performance trade factors. The trade factors were included in models of advanced aircraft/engine combinations; then mission impacts were analyzed by George Champagne of the Preliminary Design Engineering Department.

Jon A. Ralph  
Project Engineer  
Propulsion Systems Analysis

ADVANCED CONTROL FOR AIRBREATHING ENGINES

Final Report for Phases I and II Work  
Contract Periods  
October 1989 - April 1990  
October 1990 - April 1991

J. A. Ralph  
Pratt & Whitney

October 1991

Prepared for  
NATIONAL AERONAUTICS AND SPACE ADMINISTRATION  
Lewis Research Center  
Under Contracts  
NAS3-25117, Task 15  
NAS3-25952, Task 4

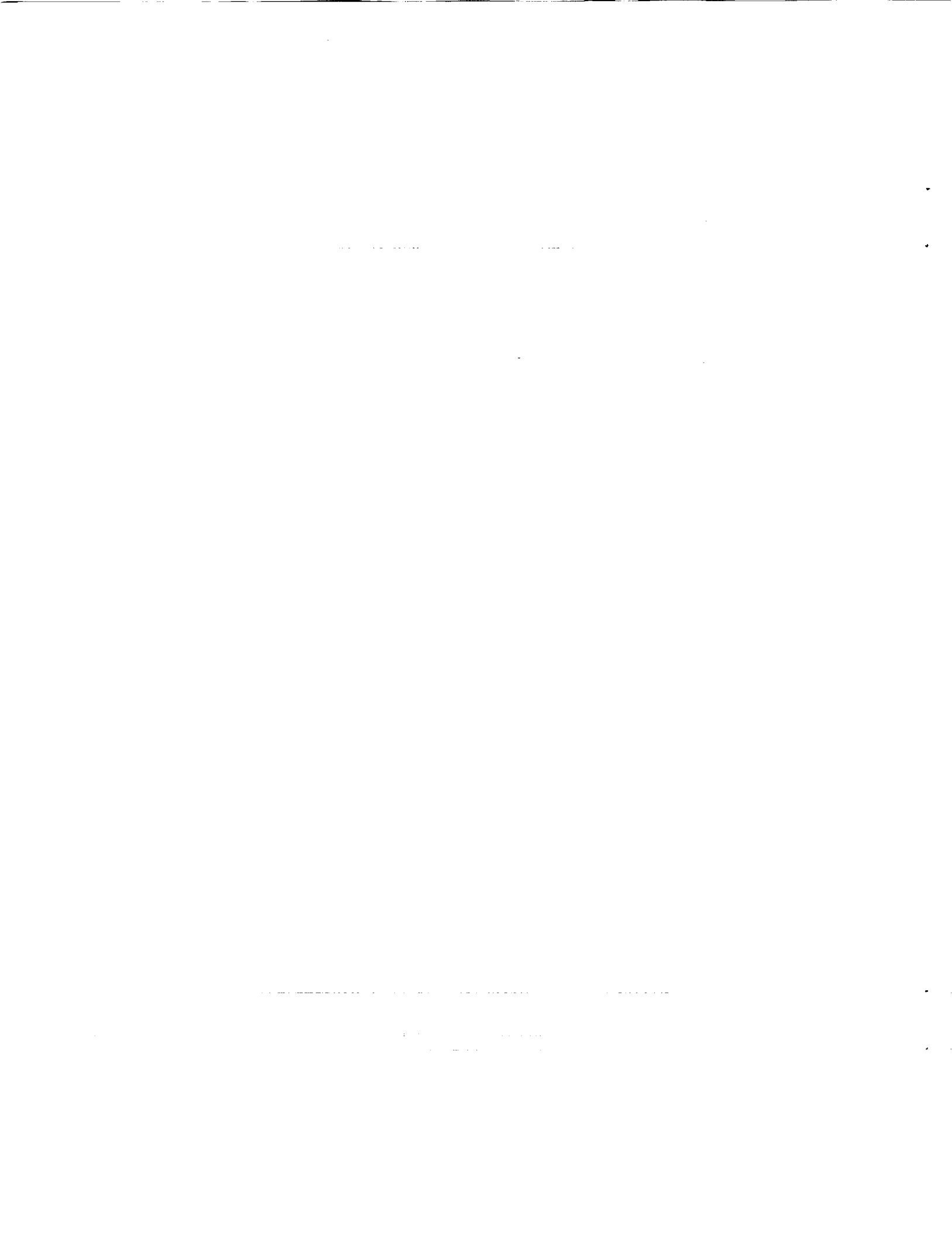



SUMMARY

Two phases of the Advanced Control for Airbreathing Engines have been completed. The objective is to quantify control concept benefits for application on a High Performance Military Fighter and on a High Speed Civil Transport (HSCT). During Phase I, candidate control concepts provided in the Statement of Work (SOW) and others included by P&W were identified and a preliminary screening was performed; then ranked for performance and operability. During Phase II, the higher ranked concepts underwent a detailed evaluation. The purpose of the second phase is to identify the control concept most desirable for development.

Figures of Merits (FOM) were selected (including complexity, risk, life cycle costs and operability impact). Takeoff Gross Weight (TOGW) impacts were determined by inserting trade factors (efficiency, cooling airflow, fuel consumption) along with controller system and engine weight contributors into the engine/aircraft models.

Normalizing factors were used to combine the FOM into a ranking list. Following a preliminary screening, eight concepts were ranked in the preliminary phase, while four were ranked during the detailed phase.

Of the nine control concepts included in the Phase I SOW, Intelligent Engine Control (IEC), Performance Seeking Control (PSC) and Stability Seeking Control (SSC) were ranked first, second, and third in both Phase I and Phase II. Active Stall Control from the SOW was tied for fifth ranking during Phase I, but due to the very high performance benefit, was selected for Phase II where it ranked fourth (of four). Three of the Phase I SOW concepts, Secondary Cooling Airflow Control, Active Noise Suppression and Active Tip Clearance control were discarded during the Phase I preliminary screening and not evaluated. The other concepts ranked during Phase I are: fourth - Active Afterburner Rumble Suppression, fifth (tied for) - Active Fuel Nozzle Staging (P&W), seventh - Afterburner Fuel Air Optimizer (P&W) and last Active Burner Pattern Factor Control.

## INTRODUCTION

This report documents work done under the first and second phases of a three phase plan, the contracts are NAS3-25117, Task 15 of the Unique Propulsion Concepts, and NAS3-25952, Task 4 of the Aeropropulsion Technology Program.

The purpose of the work is to identify and evaluate control system concepts with greatest benefit for performance and operability. Nine concepts were provided in the Description of Work that are of interest to NASA, some arising from discussions with and presentations on advanced control systems modes and logic by P&W. Pratt & Whitney experts supplied descriptions and benefits of each concept and suggested additional candidates.

For Phase II, four of the control concepts highly ranked during Phase I were selected by NASA for detailed evaluation. Based on the Phase II evaluation, the Intelligent Engine Control concept is recommended for development for use on the HSCT and Active Stall control is recommended for development on the Military High Performance Fighter.

A commercial application (HSCT) and a military application (MHPF) were specified for the evaluations. While advanced aircraft/engine were required, the need for detailed computer models of the engines and aircrafts restricted combinations to be developed in the late 1990's time span. For Phase I, a 891,000 pound TOGW 3.2 Mach HSCT with 940 lb./sec. engine airflow with dual spool, duct burning engines were used in the evaluation. For the Phase II, the HSCT has become a 742,000 pound TOGW, 2.4 Mach aircraft. The engine's were also down sized to 580 lb./sec. airflow single spool, non augmented.

The procedure utilized in the two phases was broken down into three tasks. In the first task of Phase I and Phase II, description (including block diagrams) of each concept was prepared by experts. Reference aircraft/engine combinations and figures of merit were identified in Task 2. Performance trade factors were identified, calculated and included in the engine cycle models where engine data weight and fuel burn (TSFC) impacts were computed. These were included with the concepts controller weight in the aircraft mission model. Changes in TOGW from the missions were scaled and combined with operability FOM's in Task 3 to prepare a ranking with concepts desirable for further evaluation at the top. Four of the highly ranked Phase I were selected by NASA for the detailed evaluation of Phase II. Detailed descriptions were prepared including rationale for the concept, control block diagrams, hardware/software requirements and critical technologies.

Additional FOMs including noise suppression, fault detection/accommodation, thrust response and thermal cycles were included with Phase II FOMs. As with Phase I, performance trade factors and controller weights were determined, engine fuel burner was calculated and aircraft TOGW was determined. Again, scaled TOGW was included with normalized FOMs to rank the concepts.

MAIN TEXTPhase I - Preliminary Evaluation

In October 1989, Pratt & Whitney (P&W) Government Engine & Space Power (GESP), formerly GEB, was awarded a task order contract under the Advanced Unique Propulsion Concepts (APC) program: "Advanced Control for Airbreathing Engines," NASA Lewis Contract NAS3-25117, Task 15. The objective of the study was to quantify benefits for application to a Military High Performance Fighter (MHPF) and a High Speed Civil Transport (HSCT). The purpose of the study was to identify and perform a preliminary screening of various advanced control concepts for improved engine performance and operability. The task order "Description of Work" was broken down into three subtasks. Subtask 1 - "Establish Control Concepts," Subtask 2 - "Establish Basis of Comparison," Subtask 3 - "Screening of Control Features" and Subtask 4 - Reporting. The format of the text will follow the activities accomplished in the subtasks.

Subtask 1 - Established Control Concepts:

Compile and describe control concepts which improve turbine engine performance and operability. The Description of Work contained an initial list of control concept candidates:

- o Active burner pattern factor control (BPF)
- o Stall/surge control (ASC)
- o Secondary cooling airflow control (SCAC)
- o Active compressor inlet distortion control (SSC)
- o Active noise suppression (ANS)
- o Active tip clearance controls (ATC)
- o Active afterburner rumble suppression (RUMB)
- o Performance seeking/maintaining control (PSC)
- o Intelligent diagnostic/control systems (IEC)

Ideas and consultation were provided by experts familiar with aspects of the listed control concept candidates in both commercial engine and military engineering groups. They provided descriptions of the concepts and helped prepare block diagrams. Additional control concepts candidates were solicited from them. The candidates added to the preliminary list are:

- o Active fuel nozzle staging (AFN)
- o Afterburner fuel-air optimizer (F/A OPT)

Descriptions and Block Diagrams of Phase I concepts are included in Appendix A.

Subtask 2 - Establish Basis of Comparison:

Select two reference aircraft/engine combinations for comparative evaluations and propose Figures of Merit (FOM) for the evaluation.

Engine/Aircraft Selections

Engines and aircrafts with models and simulations were required to provide the detailed evaluations needed in the next subtask. Missions were required for the aircrafts along with takeoff weights and thrust loading. For the engines, sizes, fuel burn, airflows and efficiencies were needed for incremental studies with trade factors identified for the concepts. The engine/aircraft combinations selected were:

Mach 3.2 High Speed Civil Transport

o	Base mission range	5000 N. Miles
o	Subsonic diversion range	260 N. Miles
o	Loiter time	30 Minutes
o	Pay load (250 passengers)	61,500 lbs.
o	Takeoff thrust loading (thrust/TOGW)	0.3
o	Takeoff gross weight (TOGW)	891,000 lbs.

The engines for the HSCT are duct burning dual spool turbofans with:

o	Required engine airflow	940 lbs./sec.
o	Sizing noise goal	FAR Stage 3
o	Take off thrust (per engine)	67,000 lbs.
o	Engine weight	14,066 lbs.
o	Bypass ratio	1.05

High Performance Military Aircraft (Derivative Advanced Tactical Aircraft  
(based on late 1990 availability)

o	Takeoff gross weight	47,760 lbs.
o	Takeoff thrust loading (thrust/TOGW)	1.26
o	Subsonic cruise radius (Mn = 0.9)	200 N. Miles
o	Supersonic cruise radius (Mn = 2.0)	200 N. Miles
o	Loiter time	20 minutes
o	Payload	2200 lbs.

Engine (based on Generation V) an afterburning, two spool turbofan with axial flow nozzle:

o	Engine airflow	230 lbs./sec.
o	Takeoff thrust	30,200 lbs.
o	Engine weight	3092 lbs.
o	Bypass ratio	0.19
o	Engine sizing --	
-	Excess power (30K/0.9, Max A/B)	550 ft./sec.
-	Load factor (30K/0.9, Max A/B)	5.0

Figures of Merit

Also during Subtask 2, Figures of Merit (FOM) were selected -- which measure impact of the control feature. The performance FOMs used are:

- o TOGW: takeoff gross weight
- o TSFC: thrust specific fuel consumption

These are performance indicators that combine engine thrust, fuel burn, control concept weight penalty and engine weight impact.

FOMs that will be used to evaluate operability benefits are:

- o Stall margin
- o Starting impact

and other FOMs include:

- o Complexity : Very simple to very complicated
- o Risk : Very low to very high
- o Life cycle costs : Improved to worsened
- o Diagnostics capability
- o Analytical redundancy

Preliminary Screening

Prior to the detailed evaluation of Subtask 3, the list of eleven candidate concepts was given a preliminary screening. Three candidates were not selected for further evaluation. Active Secondary Cooling, Active Noise Suppression and Active Clearance Control. Active Secondary Cooling, including both turbine airfoil and afterburner liner-nozzle cooling, did not benefit either engine/airframe combination. For turbine airfoil active cooling, TSFC benefits are

offset by increased weight and cost of cooling apparatus, cooling airflow capability is reduced significantly to provide outflow margin requirements which eliminate modulation of airfoil leading edge and pressure side cooling. Afterburner and nozzle designs of both engine/aircrafts are not appropriate for active cooling -- the low bypass military engine does not use mixed flow augmentation, but has the entire bypass stream for cooling while the HSCT configuration used in the evaluation uses duct burning, rather than afterburning. Active Noise Suppression has no obvious operability or performance benefit for military aircraft (Survivability/Vulnerability; not part of the SOW), in fact noise reduction reduces system performance. For HSCT designs, engines are designed to meet the FAR noise requirements, with a stowable, mechanical noise suppressor, or are oversized for lower power takeoff. Also, no significant effort is underway to pursue use of the engine control to suppress noise for commercial engines. Active Clearance Control was not selected for evaluation because much of the concept is already being used in commercial and military (F117) transport engines. The application is not closed loop at this time, but the technology is available with tip clearance measurements common on research/development engines. Military fighter engines are not good applications of the concept because advanced engines incorporate split case design (that tend to ovalize during operation) and the engines do not operate at steady-state conditions for extensive periods of time.

### Design Analysis

Preliminary design analyses were performed on the remaining eight control concept candidates. Trade factors were calculated for the candidates and control concept weight and engine weight impacts were determined for use in the engine cycle models. The trade factors included increased fan and core stall margin, increased maximum afterburner fuel flow and reduced primary fuel flow, along with cooling airflow increments. The weight penalty for the control components were estimated as:

<u>System Components</u>	<u>Estimated Weight</u>
Temperature sensor with cable	1. lbs.
Pressure sensor/pneumatic tube	1.5 lbs.
High response pressure sensor with cable	1. lbs.
High speed processor (stand alone)	5. lbs.
Expanded FADEC-like processor	4. lbs.
Multi-zone primary fuel distribution system	50 lbs.
Modified primary fuel manifold	10. lbs.
Solenoid with cable	3. lbs.

### Concept Trade Factors and Weight Impacts

The trade factors and weight impacts for the control concept candidates:

Burner Patter Factor Control: Up to 1% reduction in High Pressure Compressor (HPC) discharge air flow used for cooling (benefit to low turbine vanes -- blades pass through the profile and high turbine vanes are stoichimetric). 70 lbs. are added with 20 temperature sensors and an advanced fuel distribution control.

Active Stall/Surge Control: Up to 15% reduction in fan and HPC stall margin requirements, equivalent to approximately 2% increase in fan and HPC efficiencies. 29 lbs. were added for 24 (4 gangs of 6 each) high response pressure sensors and a high speed processor.

Stability Seeking Control: Up to 10% reduction in fan and HPC stall margin requirements, equivalent to approximately 1.5% increase in fan and HPC efficiencies. 4 lbs. were added for an expanded FADEC-like processor.

Afterburner Rumble Suppression: 10% higher max A/B fuel flow in the upper left portion of the aircraft envelope. 7 lbs are added for high response pressure sensors with a high throughput processor.

Performance Seeking/Maintaining Control: Performance benefits were estimated from a derivative F100 engine with a preliminary version of PSC -- the benefits are 1.5% improvement in cruise TSFC, 2% improvement in A/B TSFC and 4% higher max A/B thrust. 4 lbs are added for an expanded processor.

Intelligent Engine Control -- containing the benefits of the PSC and SSC: up to equivalent 3.8% TSFC and approximately 1.5% fan and HPC efficiencies.

Staged Fuel Nozzle: No performance benefit with a 13 lbs. added for a solenoid and modified fuel manifold.

Afterburner Fuel-Air Optimizer: Up to 2% increased in A/B efficiency with no control weight impact.

### Cycle Analysis

The trade factors were inserted into the engine cycle models. The HSCT engine cycle definition was not developed to the point of permitting weight trade studies, but the MHPF engine cycle definition was. Efficiency improvements were converted to bypass ratio resizing and then into weight reductions. Similarly reduced cooling airflow provides reduced engine weight, while increased A/B fuel flow directly resizes the engine. With the performance trade factors, controller weight impact and engine weight; TOGW was determined at the selected aircraft mission points.

Normalizing Factors

A committee of reviewers from the Advanced Technology Group within Propulsion Systems Analysis reviewed the Figures of Merit (FOM) and helped assign risk and complexity qualitative ratings. The FOMs and TOGW are summarized in the following chart -- FOM Summary Chart (Table 1). Since both qualitative and quantitative factors are included, a normalizing schedule was used to allow ranking the candidate concepts.

Normalizing Individual FOMs

Complexity:	very simple	5 points
	very complex	1 point
Risk:	very low	5 points
	very high	1 point
LCC:	Better	1 point
	Worse	-1 point
TOGW:	Smallest Improvement	0 points
	Largest Improvement	10 points
	(Linear Interpolation)	

Ranking

The normalized ranking is shown in the "Concept Ranking Chart." (Table 2)  
The top four concepts are:

IEC : Intelligent Engine Control  
PSC : Performance Seeking Control  
SSC : Stability Seeking Control  
RUMB: Active Afterburner Rumble Suppression



TABLE 1  
F O M S U M M A R Y C H A R T

<u>Concept</u>	<u>AFM Delta TOGW</u>	<u>HSC Delta TOGW</u>	<u>Complexity</u>	<u>Risk</u>	<u>LCC</u>	<u>Other FOM</u>
IEC	-6.2%	-4.2%	Moderate	Low	Better	Fault Accom., redundancy
PSC	-2.3%	-3.5	Simple	Very low	Better	
SSC	-3.6%	-0.7%	Simple	Very low	Better	
RUMB	-0.4%	0	Very simple	Very low	Better	
SFN	+0.4%	+0.1%	Simple	Very low	No. Imp.	Starting
ASC	-3.7%	-0.9%	Very complex	Very high	Better	
F/A OPT	-0.3%	0	Very simple	Moderate	Better	
BPF	+1.2%	+0.5%	Very complex	Moderate	Worse	

TABLE 2  
C O N C E P T   R A N K I N G   C H A R T

<u>Concept</u>	<u>Complexity</u>	<u>Risk</u>	<u>LCC</u>	<u>Other FOM</u>	<u>AFM TOGW</u>	<u>HSCT TOGW</u>	<u>SUM</u>	<u>RANK</u>
IEC	3	3	1	4	10	10	31	1
PSC	4	5	1	0	5	9	24	2
SSC	4	5	1	0	6	4	20	3
RUMB	5	5	1	0	3	3	17	4
SFN	4	5	0	2	1	3	15	5t
ASC	1	1	1	0	7	5	15	5t
F/A OPT	4	3	1	0	3	3	14	7
BPT	1	3	-1	0	0	2	5	8

Phase I Summary

Control concepts have been identified and preliminary screening of high payoff advanced control concepts has been completed. The top four ranked concepts are:

- o Intelligent engine control
- o Performance seeking control
- o Stability seeking control
- o Active afterburner rumble suppression

These top ranked concepts are both simple and low risk while providing significant performance benefits. These control concepts do not require engine development simultaneously with control concept development. Benefits of these concepts are available through modification to the control system and logic, rather than engine hardware.

These control concepts need to be demonstrated and developed in a timely and credible manner to obtain maximum benefits in future engine designs.

## Phase II - Detailed Evaluation

The second phase of the program began in November 1990 and extended through April 1991. The Statement of Work contained subtasks:

- (1) Prepare a detailed description of the chosen control concepts.
- (2) Provide quantified evaluation of potential impacts on aircraft/engine performance operability, life cycle cost and control complexity.
- (3) Compare the figures of merit and develop an overall ranking.

For the second phase of the study, the NASA Lewis Research Center program manager selected four control concepts for the detailed evaluation. The concepts from Phase I are:

- o Intelligent Engine Control (IEC)
- o Performance Seeking Control (PSC)
- o Stability Seeking Control (SSC)
- o Active Stall Control (ASC)

The directions specified detailed evaluations of the control concepts benefits/costs on two engine/aircraft combinations as was directed during Phase I:

- o Military High Performance Fighter (MHPF) aircraft with a generation IV (ATF) technology engine.
- o A 2.4 Mach High Speed Civil Transport (HSCT) aircraft and engine.

The MHPF aircraft/engine sizing/definition selection was that used for Phase I, an afterburning turbofan engine with 230 lb/sec airflow with a 47,700 lbs takeoff gross weight (TOGW) aircraft. The HSCT aircraft/engine was redefined; a TOGW of 742,000 lbs with a mission of 5000 nautical miles and 30 minutes loiter time. The payload is 53,100 lbs. The engine for Phase 2 is a Turbine Bypass Engine (TBE) that is a single spool, non augmented design. The engine is sized for 580 lbs/sec airflow with a takeoff thrust loading of 0.25. The cycle is Pratt & Whitney's preferred engine cycle selected under Task 002 of the Unique Propulsion Systems Contract (NAS3-25954), and the cycle deck has been defined to the extent necessary for performance trade-offs.

Subtask 1 of the SOW request that "Detailed Descriptions" be provided including:

- o Rationale for the Concept
- o Control Block Diagrams
- o Hardware Requirements
- o Implementation Time Frame
- o Development and Implementation Critical Steps

These detailed descriptions and block diagrams of Phase II concepts are included in Appendix B:

#### Life Cycle Costs

During Phase I, Life Cycle Costs (LCC) were included as one of the Figures of Merit (FOM). For evaluation purposes, the qualitative estimates were used; improves, no impact, or worsens with numerical range of +1, 0 and -1 for summaries. For the detailed evaluation of Phase II, a quantifiable analysis was completed.

The LCC analysis includes assigning costs for each phase of engine ownerships:

RDT & E: Engine development costs through qualification testing with estimates of post qualification testing costs.

Acq: Acquisition, costs for yearly basis with a learning curve on costs.

O & S: Operating and Support considering parts wear and replacement rate.

CIP & FT Component Improvement Program and Flight Test support.

The control concept features may reduce some costs while increasing others. RDT&E costs will increase with more control complexity requiring more research and development during both for design activity and development testing. RDT&E

costs will be reduced because of improved engine safety with diagnostic/redundancy improvements from the concepts that may reduce/eliminate potential engine damage during development testing. Since the RDT&E costs are small (5 to 10% are typical) and both positive and negative impacts are involved, no impact was included in the analysis.

Acquisition costs are raised due to the complexity of the new technology. For the analysis, the additional cost of the concepts were scaled based on the complexity FOM and the typical 15/25% baseline cost for acquisition.

O&S costs include parts that break down due to new part failures (reliability) which decreases with cumulative operating time on the engine model; durability, life-limited failures that increase according to statistical estimates; and random failures from foreign object damage, human errors and defects. The estimated Unscheduled Engine Removal rate is the sum of the three, reliability, durability and randoms. The typical cost of O&S is approximately 20%, while fuel burn costs are nearly 50% of LCC. For the analysis fuel burn costs were scaled using the overall TSFC improvement with each concept's durability type failures. The typical O&S LCC was broken down into approximately 40% for durability, 30% random and 30% reliability. Using these assumptions, complexity assignments, computed fuel burn impacts and other benefits of the concepts (stall probability, temperature level, redundancy and secondary damage avoidance) the results are:

#### Effect of Concepts on LCC (%)

	Active Stall <u>Control</u>	Stability Seeking <u>Control</u>	Performance Seeking <u>Control</u>	Intelligent Engine <u>Control</u>
For MHPF	-1.63	-0.90	-3.70	-5.30
For HSCT	-2.05	-0.70	-3.78	-6.33

#### Control System Component Weight Impact

The incorporation of the control concepts requires additional weight for the control components to be included in the overall engine weight. High response pressure sensors and a high response processor are required by the ASC. Optical pressure sensor/cable/connectors weigh 0.75 pounds, while the high speed processor weighs 5 pounds. With dual rakes (circumferentially dispersed) of 8 sensors each located in both the fan and the high pressure compressor (32 sensors total) the overall weight change is +29 pounds. For the SSC concept, no additional sensors or actuators are required but the existing FADEC must be expanded; adding 4 pounds to the engine weight. For the PSC concept, no additional sensors or actuators are required but 4 pounds is added for the FADEC expansion. For the IEC, the FADEC expansion adds 4 pounds, but the additional analytical sensor suite included in the real-time, on board

engine model, the level of hardware redundancy could be reduced. The weight of a sensor set is 14 pounds. Since the level of redundancy has not been defined (2, 3 or 4), half of the set was removed (7 pounds) for the detailed evaluation; so the weight impact for the IEC concept is -3 pounds.

#### Cycle Impacts on Engine Weight

The cycle definition included in the performance model of the High Performance Military Fighter Aircraft engines is fully defined. Engine cycle trade studies are possible with complete descriptions of the compression system components. With the models, the predicted reduction in stall margin remaining requirement, permitted by the Active Stall Control, Stability Seeking Control and the Intelligent Control, reduced engine weight. The reduced stall margin remaining was converted into component (fan and HP compressor) efficiencies using available trade factors. With improved component efficiencies, the engine airflow modification permitted resizing the bypass ratio, substantially reducing the engine weight. The cycle definition for the HSCT at the time of the analysis was not defined to the extent that cycle trade studies were possible. No engine weight reductions were included in the analysis for the HSCT.

#### Compression System Component Weights

Operating the compression system with closed loop control systems that eliminate stalls would allow reducing the component weights. Designs of the blades, vanes, disks and static structures must tolerate the loads applied by stalls; surplus weight if stalls are eliminated. Considerable design effort is required to determine the weight reduction; no weight impact was used for this evaluation.

#### HIDEC/PSC Control System

For the Phase I of the Advanced Control Concepts study the performance and operability benefits for the Performance Stability Control were determined using fuel burn improvements from results of the Highly Integrated Digital Electronic Control (HIDEC) program. While the fan upmatch improvements, also included in the HIDEC, were part of the Stability Seeking control for both phases of this study. SSC for this study includes both fan and high pressure upmatch capability, along with multi-variable control system design that attenuates transient stall margin excursions by controlling pressure ratios of both components.

With PSC defined as has been tested in the NASA sponsored program, it has been asked if Stability Seeking Control provides additional benefit. Using the benefits and trade factors of Phase I, the TOGW results are:

TOGW (%) Improvements with Concept Combinations					
	PSC (Study)	SSC (Study)	IEC (Study)	PSC (HIDEC)	HIDEC PSC wSSC
<u>Aircraft/ Engine</u>	<u>Fuel Burn</u>	<u>Fan Upmatch &amp; HPC Upmatch</u>	<u>Fuel Burn &amp; Fan &amp; HPC Upmatch</u>	<u>Fuel Burn &amp; Fan Upmatch</u>	<u>Core Upmatch</u>
MHPF	-2.3	-3.6	-6.1	-4.2	-1.9
3.2 HSCT	-3.5	-0.7	-4.2	-3.8	-0.4
2.4 HSCT	-1.4	-0.7	-2.1	-1.4	-0.7

The table shows 1.9% reduction in Take Off Gross Vehicle Weight for the advanced military application and 0.4% and 0.7% for the two HSCT versions, showing that the undeveloped part of the SSC (core upmatch only) is still a significant improvement. The definitions for Phase 2 are the same as Phase 1: Fuel burn only in PSC, and SSC includes both fan and HP compressor upmatches.

#### Figures of Merit

As with Phase 1, Figures of Merit (FOM) were used to evaluate characteristics of the control concepts. FOMs were quantified so that the benefits of each concept could be summed to establish an overall ranking. Performance, operability, life cycle cost, risk and control complexity were determined for each concept. The normalizing schedule for the FOMs used for the Phase 2 evaluation is:

#### Normalizing Schedule for FOMs

o Complexity:	Very simple	5 points
	Very Complicated	1 points
o Risk	Very Low	5 points
	Very High	1 points
o Life Cycle Costs:	Small Improvement	0 points
	Large Improvement	3 points
o TOGW:	Smallest Improvement	1 points
	Largest Improvement	10 points
o Other FOMs:	List Features	2 points/feature



Phase II Evaluation

Performance and operability benefits were determined and converted into parameters that are input into the engine cycle deck. The Phase I procedure was repeated for Phase 2.

Trade Factors and Figures of Merit for ASC

For the Active Stall Control, 10% reductions in fan and HP compressor stall margins requirements were converted to 1.4% efficiency improvements for each component. The ASC is projected to reduce the stall margins from the current 25% to 15%. The improvement is available by eliminating the need for worst case scenario stall margins during favorable engine operating conditions. After demonstration by rigorous testing that ASC can achieve substantial performance benefits, it may be possible to further reduce the margin requirement by another 10%; operating with 5% stall margin remaining. 10% reductions in both fan and HP compressor stall margins were used for the Phase II evaluation.

- o Control concept component weighs for the ASC are +29 pounds for 32 optical pressure sensors and a high speed processor; conventional pressure sensing devices would weigh approximately double.
- o Complexity                      Very Complex
- o Risk                                Very High
- o Life Cycle Costs                -1.8%
- o Damage Tolerance                Improved
- o The concept is ranked "Very Complex" due to the large number of sensors needed, as well as a processor that is unlike any in current engine control system.
- o The concept is ranked "Very High Risk" based on the need to measure high response pressure variations and extract signatures, process, and analyze them, and reset control system effectors in the short time period preceding stalls. The algorithms, measurement system and installations must all be developed.
- o The Life Cycle Costs were determined using the technique described in the LCC section.
- o Damage Tolerance is an added benefit for the ASC concept. Non catastrophic damage to the turbo machinery occasionally cause engine non recoverable stalls which result in aircraft loss. ASC could eliminate the secondary engine damage due to the stalls.

Trade Factors and Figures of Merit for SSC

- o For the Stability Seeking Control concept, 5% reductions in fan and HP compressor stall margin requirements were converted to 0.7% efficiency improvement for each component. The improvement is less optimistic than the 10% stall margin requirement reduction used for Phase I. Experts believe that the 5% improvement is achievable, but should be demonstrated before attempting to reduce the margins by 10%.
- o Control concept component weights for the SSC concept are +4 pounds for expanding the FADEC processor. No additional sensors or effectors are required for the SSC.
- o The complexity of SSC is ranked "Simple" since no new components are needed and the added logic is similar to existing logic or has successfully included in models.
- o Risk of SSC is ranked "Low". The stability audit algorithms are available and are regularly utilized off-line. The engine control modes that provide gracious transients have been demonstrated on real-time control system benches.

The Life Cycle Costs were determined using the technique described in the LCC section.

There are no "Other" Figures of Merits to be included in the SSC evaluation.

The Figures of Merit are:

Complexity	-	Simple
Risk	-	Low
Life Cycle Costs	-	-0.8%
Other FOMs	-	None

Trade Factors and Figures of Merit for PSC

For the Performance Seeking Control concept, reductions in gas generator fuel burn were inserted in the engine cycle model. Reductions were extracted from simulation results from the HIDEDEC/PSC at the aircraft/engine operating points of the Fighter mission profile. At the sizing point, 30K ft altitude and 0.9 mach and maximum augmentation, a 4% improvement in specific fuel consumption (TSFC) was predicted. A 2% improvement in TSFC at supersonic cruise (Mn=2.0), and a 1.5% improvement in TSFC at subsonic cruise (Mn=0.9) were also included in the model.

- o Control concept component weights for the PSC concept are +4 pounds for expanding the FADEC processor. No additional sensors or effectors are required for the PSC.
- o The complexity of SSC is ranked "Moderate"; supervisory logic engine update logic, executive logic and optimization routine must be integrated into the controller. A real time engine model with Kalman filter is also included in the system.
- o Risk of PSC is ranked "Very Low" since Pratt and Whitney has designed, integrated and tested portions of the concept. A optimization routine has been developed by MacAir and used in the HIDEDEC/PSC program.
- o The Life Cycle Costs were determined using the technique described in the LCC section.
- o There are no "other" Figures of Merit to be included in the PSC evaluation.

The Figures of Merit are:

Complexity	-	Moderate
Risk	-	Very Low
Life Cycle Cost	-	-3.7%
Other FOMs	-	None

#### Trade Factors and Figures of Merit for IEC

For the Intelligent Engine Control concept, the improvements of the Stability Seeking Control and the Performance Seeking Control concepts are summed. The IEC includes fan and HP compressor upmatch improvement provided by the on board stability audit and the fuel burn reduction available with use of the real time performance optimizer. 5% reductions in fan and HP compressor stall margin improvements in the turbo-machinery were input into the cycle balance. From the fuel burn reductions from PSC, the changes in TSFC are: 4% improvement at the engine sizing condition (30K/.9/max), 2% improvement at supersonic cruise and 1.5% improvement at subsonic cruise.

- o Control concept component weights for the IEC concept is -3 pounds, +4 pounds for an expanded FADEC less half of a sensor suite (possibly one suite or none) at 7 pounds.
- o The complexity of IEC is ranked "Complex" since it is more complex than either the SSC (Simple) and PSC (Moderate) which combine to form the IEC with the addition of the multivariable control system and the real time on board engine model.

- o The risk of the IEC's ranked "Moderate"; more risky than either of its parts. There are no known technical reason that the concept can not be implemented and developed.
- o Life cycle costs were determined using the technique described in the LCC section.
- o The IEC concept with its real-time on-board engine model has additional in-range sensor and fault isolation/accommodation providing redundancy/diagnostics. The model also provide the capability of improved engine/aircraft damage tolerance. With the addition of mission adaptive mode, the control system may be placed in a "quick" thrust mode for combat situations, or in a "precise" mode for approach/refueling/formation flying. In a life-enhancing mode, thermal cycles are minimized by limiting rotor excursions during transients; an active airfoil strain limiter.

The Figures of Merit are:

Complexity	-	Complex
Risk	-	Moderate
Life Cycle Costs	-	-5.8%
Other FOMs	-	Improved Damage Tolerance
	-	Improved Redundancy/Diagnostics
	-	Quicker/Precise Thrust Response
	-	Lower Rate Thermal Cycles

#### Detailed Cycle Analysis

The trade factors were included in the engine cycle deck by George Champagne of the Preliminary Design Engineering group; as was done for Phase I. The trade factors were: fuel burn reductions, component efficiencies and concept weights. The fan and HP compressor efficiency improvements permitted resizing the MHPF core and increasing the bypass ratio. Engine weight reductions resulted for the ASC, SSC and IEC concepts for the fighter engine application. Similar weight reductions were not possible for the HSCT engine since the model definition did not permit the trade-off. Since the HSCT is a single spool, the efficiency improvement would result in lesser weight benefit. The Take-Off Gross Weight (TOGW) for the concepts are shown in the following Table 3 for the MHPF and in Table 4 for the HSCT. The TOGW for both applications range from the SSC concept with the smallest improvement, up to the IEC concept, which has the largest improvement.

#### Summary of Figures of Merit

A summary chart of the Figures of Merit for the four concepts is included in Table 5. The FOMs were assigned the numerical factors previously identified; and the ranking chart with the normalizing factors was prepared, Table 6.

# ADVANCED CONTROLS

## FIGHTER ENGINE

<u>Concept</u>	<u>BASE</u>	<u>ASC</u>	<u>SSC *</u>	<u>PSC</u>	<u>IEC *</u>
Fan Efficiency, %	83.1	84.5	83.9	83.1	83.9
Compressor Efficiency, %	87.5	88.9	88.3	87.5	88.3
Bypass Ratio	0.19	0.26	0.23	0.19	0.23
$\Delta$ Weight (Cycle/Comp), Lb.	-----	-77.	-45.	0.0	-45.
$\Delta$ Weight (Control), Lb.	-----	29.	4.0	4.0	-3.0
$\Delta$ TSFC (Subsonic), %	-----	-2.0	-1.1	-1.5	-2.6
$\Delta$ TSFC (Max A/B), %	-----	0.0	0.0	-4.0	-4.0
$\Delta$ TSFC (Part A/B), %	-----	0.0	0.0	-2.0	-2.0
$\Delta$ TOGW (Engine Weight), %	-----	-2.3	-1.3	0.0	-1.3
$\Delta$ TOGW (TSFC), %	-----	-0.9	-0.5	-2.5	-3.0
$\Delta$ TOGW (Control Weight), %	-----	0.9	0.1	0.2	0.0
$\Delta$ TOGW (Total), %	-----	-2.3	-1.7	-2.3	-4.3

\* with -5% stall margin requirements.

Table 3. Fighter Engine TOGWs, Phase 2

# ADVANCED CONTROLS

## SUPERSONIC TRANSPORT ENGINE

<u>Concept</u>	<u>BASE</u>	<u>ASC</u>	<u>SSC *</u>	<u>PSC</u>	<u>IEC *</u>
Compressor Pressure Ratio	12.8	12.8	12.8	12.8	12.8
Compressor Efficiency, %	87.4	88.3	88.2	87.4	88.2
Engine Weight, Lb.	15850	-----	-----	-----	-----
$\Delta$ Weight (Cycle/Comp), Lb.	-----	0.0	0.0	0.0	0.0
$\Delta$ Weight (Control), Lb.	-----	29	4.0	4.0	-3.0
$\Delta$ TSFC (Subsonic), %	-----	-0.8	-0.45	-1.5	-2.0
$\Delta$ TSFC (Supercruise), %	-----	-0.5	-0.3	-1.5	-1.8
$\Delta$ TOGW (Engine Weight), %	-----	0.0	0.0	0.0	0.0
$\Delta$ TOGW (TSFC), %	-----	-0.6	-0.35	-1.4	-1.75
$\Delta$ TOGW (Control Weight), %	-----	0.0	0.0	0.0	0.0
$\Delta$ TOGW (Total), %	-----	-0.6	-0.35	-1.4	-1.75

\* with -5% stall margin requirements.

Table 4. HSC T Engine TOGWs, Phase 2

# ADVANCED CONTROL FOR AIRBREATHING ENGINES FIGURES OF MERIT

<u>FOM</u>	<u>ASC</u>	<u>SSC</u>	<u>PSC</u>	<u>IEC</u>
COMPLEXITY	VERY COMPLEX	SIMPLE	VERY LOW	MODERATE
RISK	VERY HIGH	LOW	VERY LOW	LOW
LIFE CYCLE COST	SLIGHTLY BET- TER	SLIGHTLY BET- TER	BETTER	MUCH BETTER
REDUNDANCY	---	---	---	ANALYTICAL
DIAGNOSTICS	---	---	---	ANALYTICAL
NOISE SUPPRESSION	---	---	SMALL IM- PROV.	SMALL IMPROV.
PRECISE THRUST	---	---	---	W MISSION ADAPT
QUICK THRUST RESPONSE	---	---	---	W MISSION ADAPT
DAMAGE TOLERANCE	W PRECURSOR	---	---	W MISSION ADAPT
LOWER STRAIN	---	---	---	W MISSION ADAPT
TOGW - FIGHTER	-3.9%	-1.9%	-4.2%	-6.2%
TOGW - HSCT	-0.9%	-1.4%	-1.4%	-2.1%

Table 5. Phase 2 Figures of Merit

# ADVANCED CONTROL FOR AIRBREATHING ENGINES

## Concept Ranking Chart, Normalized Factors

<u>FOM / CONCEPT</u>	<u>ASC</u>	<u>SSC</u>	<u>PSC</u>	<u>IEC</u>	<u>SSC *</u>	<u>PSC *</u>
COMPLEXITY	1	3	3	2	4	3
RISK	1	3	4	3	3	4
LIFE CYCLE COST	1	0.5	2	3	0.5	2
OTHER FOMS	2	0	2	8	0	2
HSCT TOGW	1.5	1.5	2	3.5	1	2.5
AMF TOGW	7	6	4	10	3	7
TOTAL POINTS	14.5	15.5	19.5	33.5	12.5	23.5
RANKING	4	3	2	1		
RANKING *	3			1	4	2

\* HIDEDEC definition of PSC (fuel burn + FAN upmatch)  
and SSC is defined as HPC upmatch only.

Table 6. Phase 2 Ranking Chart



The ranking are:

- 1st Intelligent Engine Control
- 2nd Performance Seeking Control
- 3rd Stability Seeking Control
- 4th Active Stall Control

The performance benefits of the IEC were significantly higher than any other concept; combined with the additional benefits from the on-board model and multi-variable controller added up to 36 points -- 50% higher than the second place PSC. The high risk/complexity of the ASC dropped it to the bottom ranking, although its performance figures were third.

#### Recommendations for Further Development

Intelligent Engine Control was the highest ranked concept based on both Phase I and II evaluations. The fuel optimization of the IEC along with the mission adaptive control system provide significant payoff for HSCT. While the IEC is equally attractive for the Advanced Military Fighter several portions are currently being funded/developed from several sources - HIDECC, ATEGG and JTDE, so to recommend the entire IEC be developed at one time for the MHPF is a substantial task. Since the control system for the HSCT is not yet defined, the IEC should be included in the baseline control system. To be available by the time of first engine test, decisions on the baseline control should be made as soon as possible.

The trade factors for the reductions in supersonic cruise fuel consumption are shown in Table 7. The 1.8% TSFC reduction is equivalent to more than 4 million dollars in airframe costs, or 17,300 pounds of weight per engine.

The Active Stall Control concept has high risk, but high payoff for the Military High Performance Fighter engine/aircraft system. The 10% reduction in stall margin requirement can be tracked for improved engine performance and/or lower weight for a new engine design. With the addition of thrust vectoring and supermaneuverability transient impacts on engine turbomachinery stability place greater demands for stall avoidance/suppression. Furthermore, ASC technology complements current on-going activities in Stability Seeking Control.

# RECOMMENDED PROGRAMS FOR FURTHER FUNDING INTELLIGENT ENGINE CONTROL NEEDED FOR HIGH SPEED CIVIL TRANSPORT

## FUEL OPTIMIZATION HAS SIGNIFICANT PAYOFF FOR HSCT

253 PASSENGERS/5000 NM DESIGN, \$1.00/GAL FUEL PRICE  
STJ949 TBE (650 LB/SEC AIRFLOW), YEAR 2005 EIS

TRADE FACTORS	<u>3500 NM MIXED MISSION</u>
1% SUPERSONIC TSFC =	4.6% SUBSONIC TSFC
	3.5% THRUST AT M 2.4
	960 LB WEIGHT/ENGINE
	29% NACELLE DRAG
	\$25/EFH MAINT. COST
	\$540,000 ENGINE PRICE
	\$2,300,000 AIRFRAME PRICE
	0.5% DOC + I

Table 7. HSCT Supersonic TSFC Trade Factors

Summary

- o The Phase II detailed evaluation of candidate advanced control concepts was completed. The ranking is: (1) Intelligent Engine Control, (2) Performance Seeking Control, (3) Stability Seeking Control, and (4) Active Stall Control.
- o Tremendous potential improvements in propulsion system performance and operability improvements are available through advanced control concepts.
- o To obtain maximum benefits in next generation engine designs, this technology needs to be developed and demonstrated in a timely and creditable manner.

A P P E N D I X A

PRELIMINARY DESCRIPTIONS OF PHASE I CONCEPTS

Control Concept	Page No.
Active Burner Pattern Factor Control	A1
Stall/Surge Control (Active Stall Control)	A4
Secondary Cooling Air Flow Control	A6
Active Compressor Inlet Distortion (Stability Seeking Control)	A8
Active Noise Suppression	A10
Active Clearance Control	A13
Active Afterburner Rumble Suppression	A15
Performance Seeking/Maintaining Control	A17
Intelligent Engine Control	A19
Improved Starting Control (Active Fuel Nozzle Staging)	A22
Augmentor Control System Improvements	A24

### Active Burner Pattern Factor Control

Pattern Factor (PF) is a measure of combustor exit temperature uniformity and is defined as:

$$PF = \frac{\text{Maximum Local Temperature in Combustor Exit} - \text{Average Combustor Outlet Temperature}}{\text{Average Combustor Outlet Temperature} - \text{Average Combustor Inlet Temperature}}$$

The significance of pattern factor is that it relates to the maximum local gas temperature to which the first turbine vanes are exposed and therefore influences turbine vane life and cooling flow requirements. A lower pattern factor represents a less severe environment for the turbine vanes and would enable performance improvement through reduced cooling requirements.

Extensive combustor development is conducted to achieve low pattern factor but some variation in pattern factor can occur in engines due to variation in fuel nozzle flow schedules, compressor discharge velocity profiles, and combustor and diffuser manufacturing dimensions. Pattern factor is often driven by a single hot region in the combustor outlet and an active pattern factor control could reduce fuel flow through the fuel nozzles associated with the hot spot, thereby reducing pattern factor.

The location of the hot spot(s) may vary from engine to engine, or within a given engine as a function of flight condition. Thus, the application of active pattern factor control requires highly detailed temperature measurements of the entire combustor exit flowfield and subsequent modulation of the individual fuel nozzle flows to achieve optimum gas temperature uniformity. The <sup>in situ</sup> measurement of combustor exit temperature distribution presents a formidable challenge, due to the elevated temperature levels in modern engines. Such a measurement has not been achieved at full power on even an

experimental basis, although optical pyrometry keying off carbon radiation and laser-excited Raman scattering are areas of interest. An alternative approach could be to measure first turbine vane metal temperatures around the engine, perhaps by several scanning optical pyrometers. This approach, while not addressing pattern factor directly, has the added advantage of tailoring the combustor exit temperature distribution to offset variations in cooling effectiveness from vane to vane. Thus, the temperature of the life-limiting vane is reduced whether the high vane temperature be caused by high gas temperature or vane cooling anomalies.

Measurement of the combustor exit gas temperature distribution or first vane temperature distribution has the advantage of being closely linked to the fuel distribution, i.e., the fuel flow should be reduced in the injectors immediately upstream of the hot region(s). However, measurement of the gas temperature distribution or vane metal temperatures at the turbine discharge would appear to be more feasible due to the lower temperature and pressure levels, as well as more convenient accessibility. The temperature pattern has been partially attenuated and rotated as it passes through the turbine so a "cause and effect" perturbation and modulation of individual nozzle fuel flows might be required to control pattern factor.

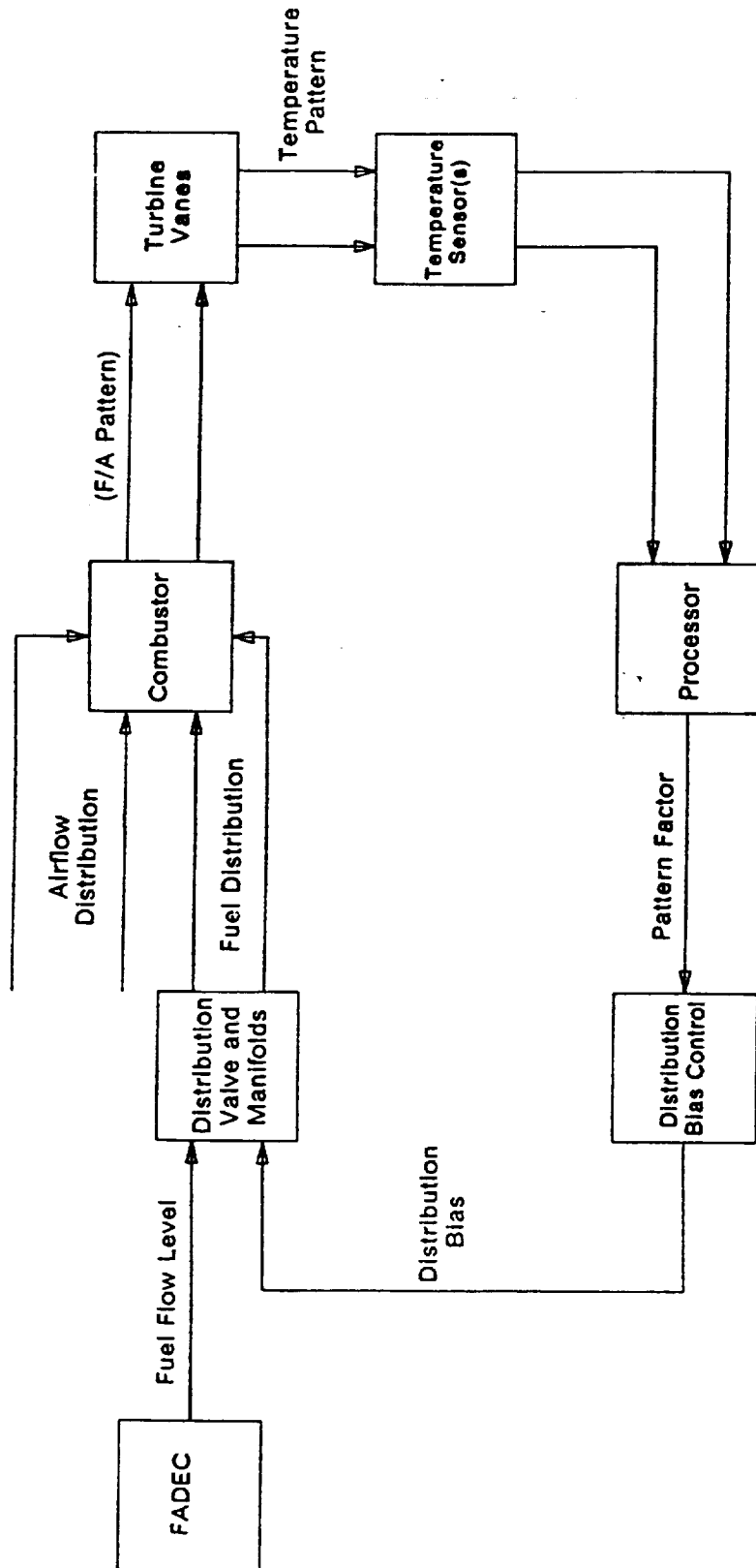

ACTIVE BURNER PATTERN FACTOR CONTROL

### STALL/SURGE CONTROL

Substantial surge margin is designed into the fan and high compressor components to maintain adequate engine stability under all operating conditions. This surge margin is intended to accommodate all destabilizing influences in their worst case magnitudes. But, under usual operating conditions, many of these destabilizing influences are either not present or are lesser in magnitude than the worst case levels, therefore the component is operating with excess stability margin. The excess stability margin comes at the expense of possible additional performance.

A new stall precursor has been identified that appears to give sufficient surge warning time for a control system to take action to suppress surge. The signal has been consistently identified in various compressor rigs and provides at least one order of magnitude more warning than previous schemes offered.

A reduction in the required design stall margin for a fan and compressor component from the current allocation of about 25 percent down to 15 percent (a 10% reduction) is projected for an active surge control system. The system can show up as an increased component performance and decreased component weight, and translates to a 3 percent increase in engine thrust-to-weight ratio with a 2 percent reduction in the specific fuel consumption. Improved engine operability and durability are also expected.



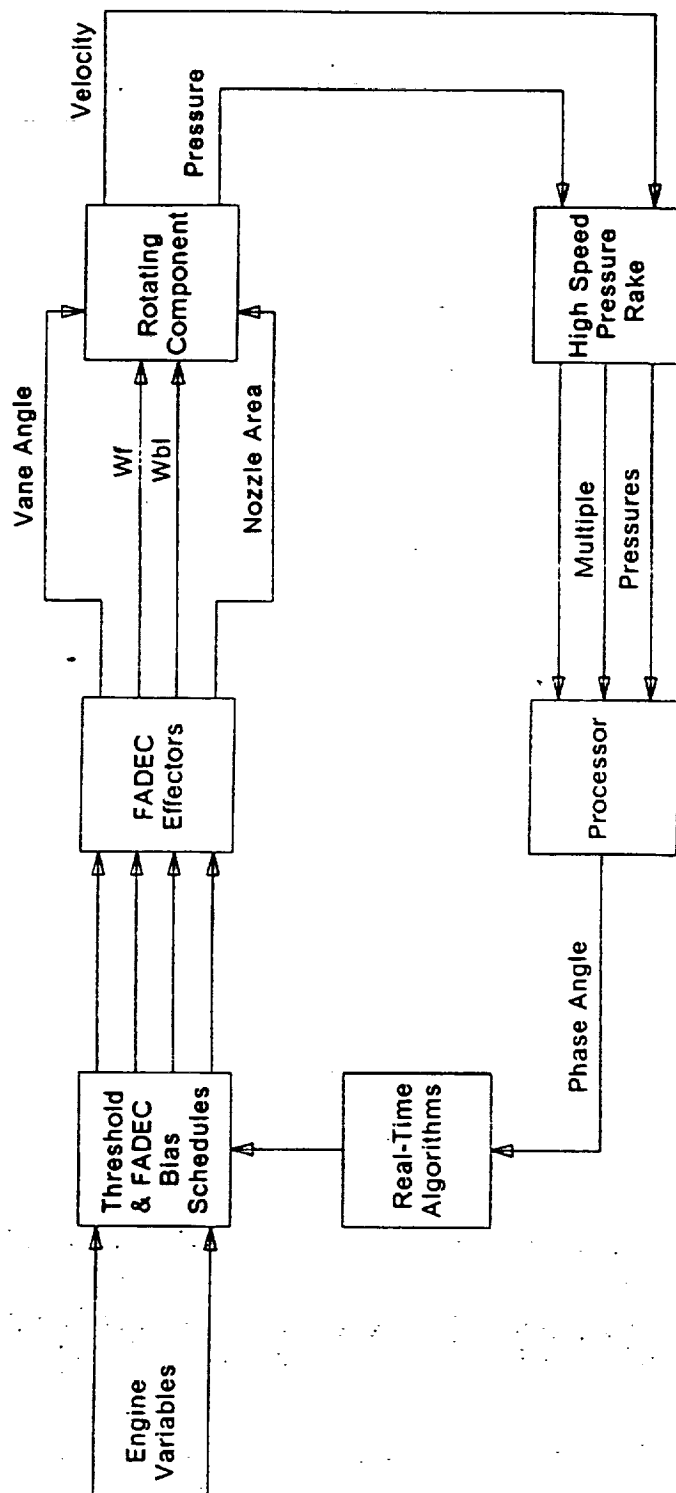

STALL / SURGE CONTROL

## SECONDARY COOLING AIR FLOW CONTROL

### Active Turbine Cooling Control

The turbine cooling air may be reduced at cruise conditions to minimize fuel consumption. At engine conditions requiring less than design turbine cooling flow, the excess cooling airflow overcools the turbine below tolerable temperatures. Extracting excess high pressure airflow from the combustion process reduces the overall efficiency. Fifteen to twenty percent of core airflow is used for high pressure cooling. Improving the cycle efficiency by reducing cooling airflow, decreases TOGW, takeoff gross vehicle weight. Reducing the cooling airflow by 25% is equivalent to a 3.5% core airflow increase.

Since turbine blade and vane life is severely effected by overtemperating, adequate airflow must be provided. Cooling airflow cannot be decreased at high power conditions. A variable area airflow control valve is positioned by an electrohydraulic servovalve with a resolver for loop closure for accuracy and response. Schedules for positioning the airflow valve are included in the Full Authority Digital Engine Control (FADEC). The airflow valve would be fully opened (the failsafe position) at takeoff and other high power conditions, and closed at altitude cruise. Measured turbine temperature (gas or metal), power lever position, measured altitude (inlet Pressure) and core rotor speed, along with temperature and pressure of the cooling airflow source, would be used in scheduling the airflow valve.

### Active Afterburner Liner/Nozzle Cooling Control

Afterburner liner/nozzle cooling design is generally driven by the lowest Bypass Ratio (BPR) operating conditions, generally extending from sea level static up through the center of the envelope. At higher BPR's the liner and nozzle are overcooled and thrust is penalized. By incorporating a control valve and distribution system, cooling airflow could be modulated as required to limit metal temperatures at design tolerable limits. Measured cooling airflow pressure and temperature and metal temperature would be used by the FADEC to schedule the control valve area. An open loop simplification of the control system would be to use the calculated BPR available in the FADEC to schedule the cooling valve area. Variations in cooling capacity would limit improvement since the schedule would provide adequate, or excess airflow at all conditions.

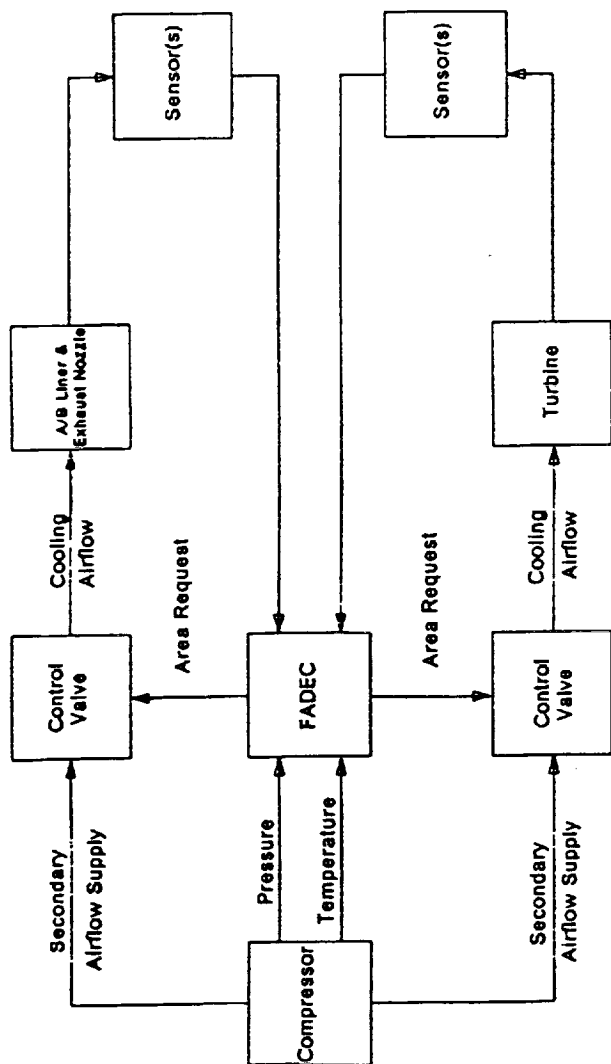

Engine Regulated Customer Bleed

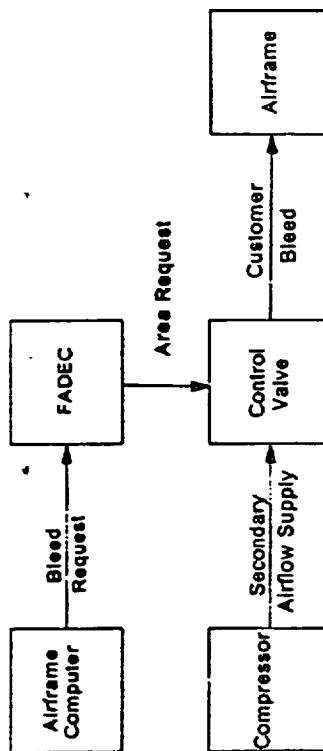

SECONDARY COOLING AIRFLOW CONTROL

## ACTIVE COMPRESSOR INLET DISTORTION

### expanded to STABILITY-SEEKING CONTROL

Current turbofan engine control modes and logic are designed to provide safe and stable engine operation under all conditions, including worst case. This design concept, although effective, requires stringent aerodynamic compressor design for stall margin, and in the process performance may be sacrificed. Stall margin requirements are allocated for both internal and external threats to engine stability. External threats, such as inlet distortion due to extreme aircraft maneuvers, have been addressed in numerous technology programs, resulting in demonstrated solutions via integrated flight/propulsion control systems. Internal threats to stability include power transients, augmentor sequencing pressure pulses, thermal case/rotor response, deterioration, etc. The internal threats appear to be more difficult to solve but may yield more significant payoffs in terms of improved engine thrust-to-weight.

The Stability Seeking Control would use control algorithms to reduce component stability margin requirements. The SSC would have stability audit techniques and correlations incorporated into the engine control logic. This would provide an on-line stability evaluation for the fan and high compressor, allowing the control to minimize the surge margins. The audit would include all destabilizing effects and all benefits that can be gained from engine inputs that are control system outputs. Awareness of control system inputs to the engine will have a two-fold impact in the SSC. First, they will minimize the stall margin required for the individual destabilizing effects. Second, they will allow the control to provide stall margin adjustment only for the magnitude of destabilizing influences that are present.

Conceptionally, a Stability Seeking Control with an on-line stability audit can calculate real-time destabilizing influences and their magnitudes rather, than assume worst case. This can result in significant reductions in the required maximum stall margin at any operating point since the worst case stack-up of destabilizing influences will rarely occur simultaneously. Even if this rare situation should occur, new scheduling techniques can evaluate and improve stability margin in real-time to accommodate this situation.

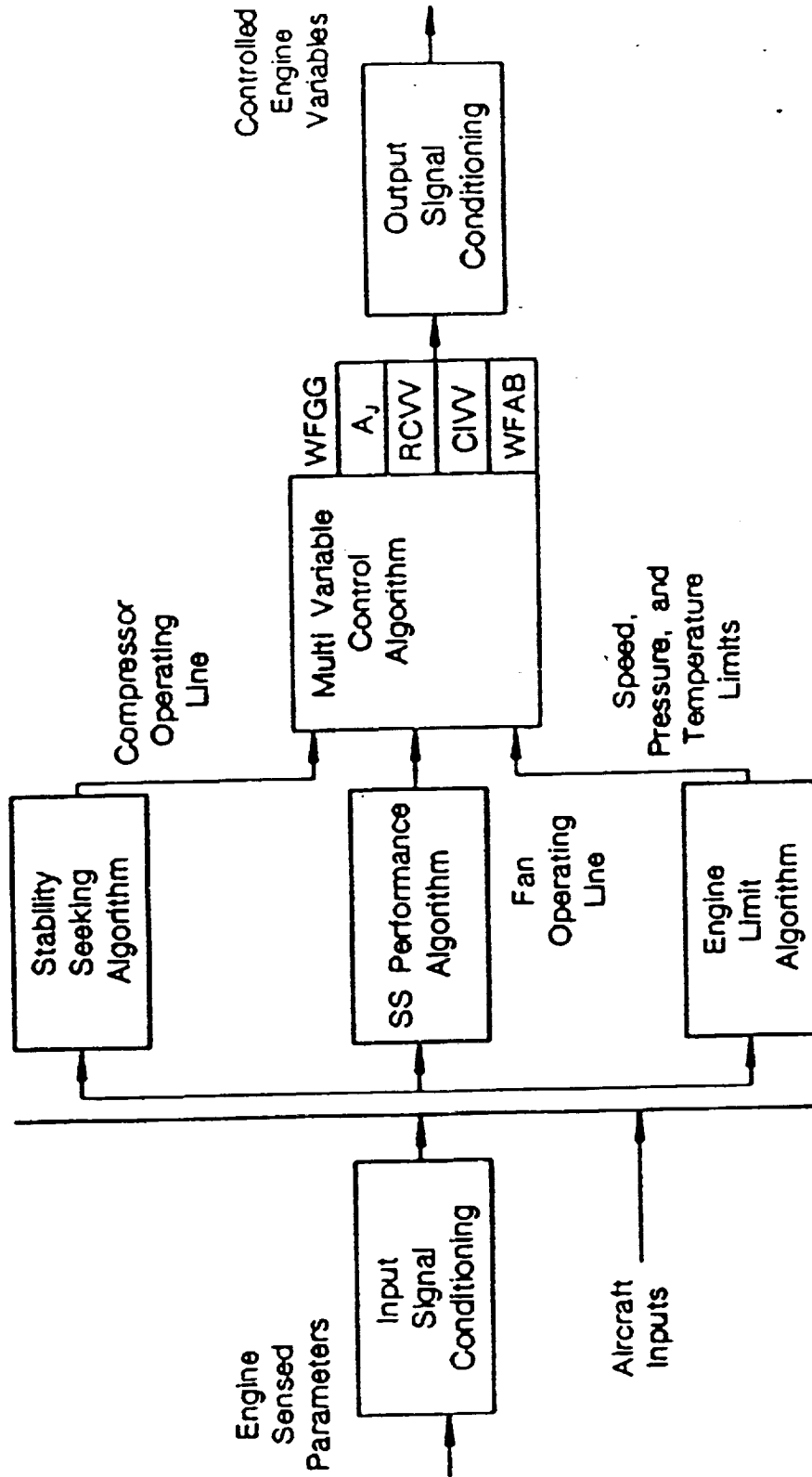

Stability-Seeking Control

## ACTIVE NOISE SUPPRESSION

Noise is unwanted sound, generated by a vibrating surface or a turbulent flow; transmitted by synchronized pressure fluctuations through a medium and received by a detector (an ear or microphone). For commercial aircraft, the major problem with noise is in terms of the number of people exposed in the vicinity of airports. Excessive noise level and duration can cause deafness, moderate levels reduce the ability to hear speech intelligibly and increase fatigue. Protective and preventive measures are required. For military aircraft, ground observers frequently hear approaching aircraft before seeing them. Noise is one of several aircraft observables that are used for target location, direction of travel and velocity. The information might be used for weapon system function including search, acquisition, tracking, fire control and guidance. Noise suppression permits unrestricted usage of commercial engines with the progressively reduced national noise regulations. Noise suppression improves the aircraft survivability of military aircraft/engine system.

A turbofan engine operating in the open generates both wide and narrow band noise spectrum from 30 to 30,000 hertz. Turbofan engine has many sources, within two categories: internal noise generated by the rotating machinery and combustion process, and external noise generated by exhaust gas jet blast. The internal noise propagates almost entirely through the inlet and nozzles, with very little emerging through the engine casing. Jet exhaust noise is generated in the turbulent mixing region behind the engine where high velocity exhaust gases mix with ambient air. Jet exhaust noise is broad-band in nature with the acoustic energy distributed widely over the frequency spectrum, but, is the predominant low frequency contributor.

Fan noise is generated primarily by flow interactions between rotating airfoils and stationary objects in the flow stream, such as stators and struts. This noise appears predominately at discrete frequencies, in the high frequency end of the spectrum with the acoustic energy concentrated at multiples of blade passing frequency. This noise propagates forward and rearward from turbofan engines. Broad-band fan noise, generated from the turbulence and airload fluctuations and multiple-tone noise, associated with shock waves caused by shock waves as also encountered.

Core noise is relatively more important for high bypass ratio turbofan engines where jet velocities, and jet noise, are reduced. Core noise consists of compressor noise, combustion noise and turbine noise. Compressor and turbine noise are similar to fan noise, resulting mainly from the interaction of the rotating and stationary blades. Combustion noise results from the turbulence generated by the burning of the fuel. Augmentors are very noisy, due to the combination of turbulence and very high jet velocities caused by the afterburning.

Noise emitted from the engine can be reduced by design, usually with added weight, length and cost. Also, compromises in aerodynamic design adversely impact engine performance. Noise suppressors were added to early commercial turbojets to reduce external noise caused by mixing hot gas with ambient air. Low bypass ratio turbofans had slightly reduced exhaust stream velocities. Exhaust gas mixers that mix fan and core airflow streams of low bypass turbofans re-

duces the exhaust steam velocity and external noise. Current commercial engines have large bypass turbofans that significantly reduce exhaust velocity and exhaust noise. Internal noise, caused by the rotating machinery, may be effectively confined by installing an acoustical liner in the engine inlet and/or exhaust duct. Other design changes to reduce internal noise are to decrease fan tip speed, increasing the spacing the rotor and stator, eliminate the inlet guide vanes and change the number of rotor and/or stator blades. Each of the noise improvements has disadvantages the include heavier and more costly engines, and may diminish the turbomachinery performance.

The sources of noise described present little or no potential for active noise suppression. Generally, noise level increases with increasing engine power level. Highest noise levels occur during takeoff conditions where canceling augmentation and reducing rotor speed would be an unacceptable solution. The active noise suppression concept is not highly rated for commercial engines since the simultaneous occurrence of maximum noise level and maximum power demand prohibit compromise. No noise level/performance compromise has been made in military engines basic design, so that active noise suppression would not improve military engine performance or operability. Noise suppression payoff would be directed toward reducing engine observables. Methods of implementing observables are considered classified, so discussion of the concept would be isolated.

Since active noise suppression does not improve performance or operability, it will be excluded from the evaluation.

ORIGINAL PAGE IS  
OF POOR QUALITY

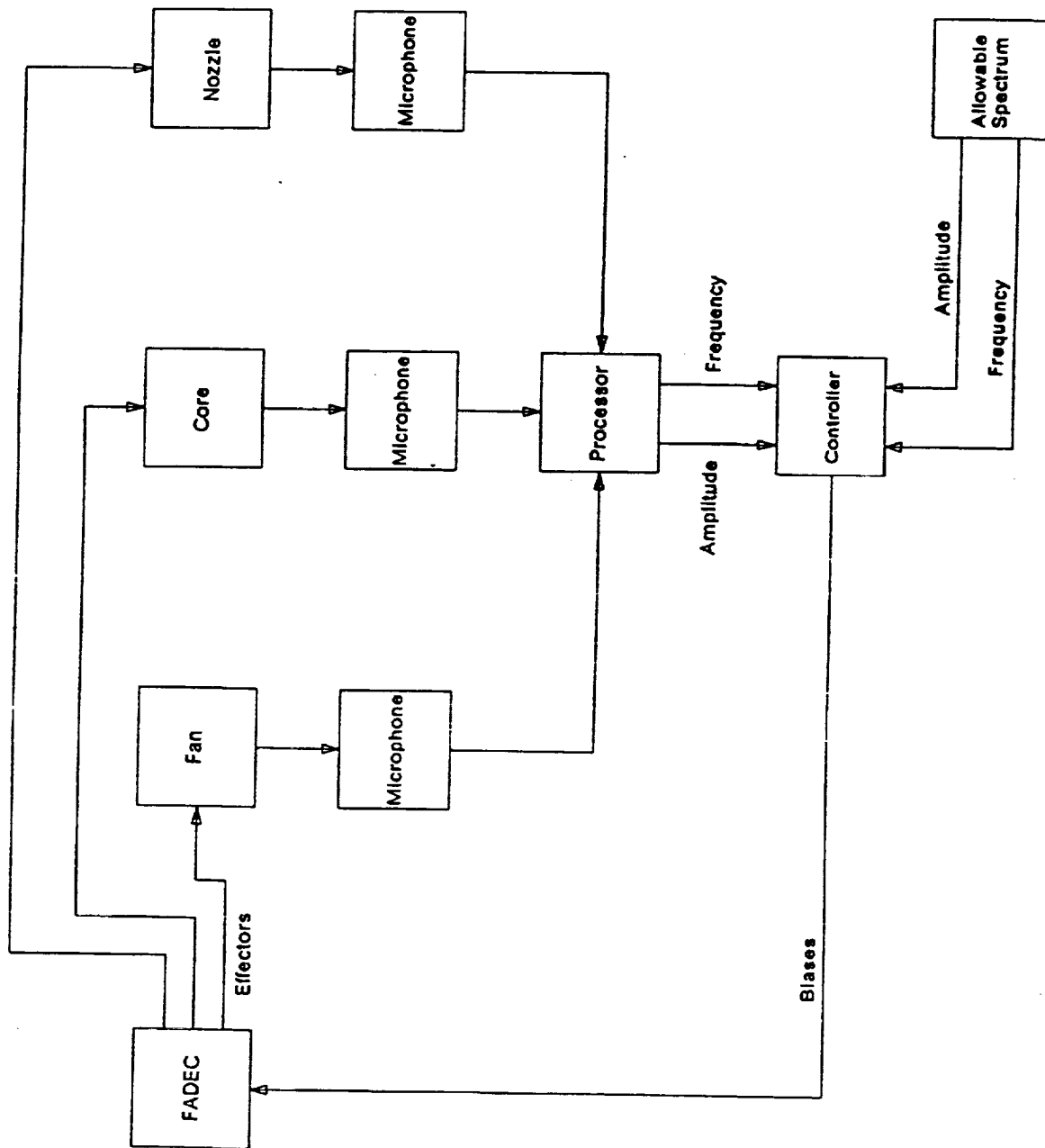

ACTIVE NOISE SUPPRESSION



## ACTIVE CLEARANCE CONTROL SYSTEM

The purpose of the Active Clearance Control (ACC) system is to increase engine efficiency (and minimizing fuel consumption) by reducing blade tip clearances. The tip clearances are reduced by shrinking the circumference of the cases. Cool air from the fan discharge is ported through air handling valves into manifolds supplying tubes surrounding the cases. Schedules for positioning the air flow valves are included in the FADEC (Full Authority Digital Engine Control). Electrohydraulic servovalves open and close the air flow valves as requested by the FADEC, and resolvers provide feedbacks to the FADEC for loop closures.

The schedules should provide fuel consumption improvements over the wide engine operating range, particularly the altitude cruise conditions. Open loop scheduling could open/close the valves as rotor speed exceeds a threshold steady state level, along with sensed inlet pressure, an indicator of altitude, dropping steady state threshold. Valve opening should be correlated with expected differential temperature between blade and the turbine case. Total closed loop active tip clearance control would require instrumenting the actual tip clearance, comparison with a desired gap, and incrementing the cooling air flow valve accordingly. Problem with closed loop controlling include variation in individual blade height, high speed blade passing frequency (roughly 10,000 blades passings per second in a very hot environment. Synthesized tip clearance from sensed engine control probably would not be sensitive enough to detect variations due to the expected efficiency changes. Possibly efficiency might be estimated using Kalman filtering within an overall 'intelligent' control system.

Failsafe conditions for an air valve supplying cooling flow to the low pressure turbine would be open; while one supplying the high pressure compressor and/or turbine would be closed.

Parts of the system described above has been included in the F117-900 engine included in the C17 aircraft. One cooling system supplies the LPT case, and another system cools the HPC and HPT. Scheduling of the air flow valves is open loop with functions of steady state core rotor speed and aircraft altitude. The benefit of tip clearance controlling on the F117-PW-100 installed in the C17 at SLS on engine performance caused by 0.91 pps cooling to HPC and HPT:

- ~ 1.8% improvement in TSFC
- 0.31% improvement in ETAHPC
- 1.4% improvement in ETAHPT
- ~ 0.32% mid-power improvement in FTALPC
- ~ 0.10% high-power
- 0.23% improvement in ETALPT

The above improvements apply to the net thrust range of 25,000 to 40,000 lbs.

ORIGINAL PAGE IS  
OF POOR QUALITY

# ACTIVE CLEARANCE CONTROL DIAGRAM

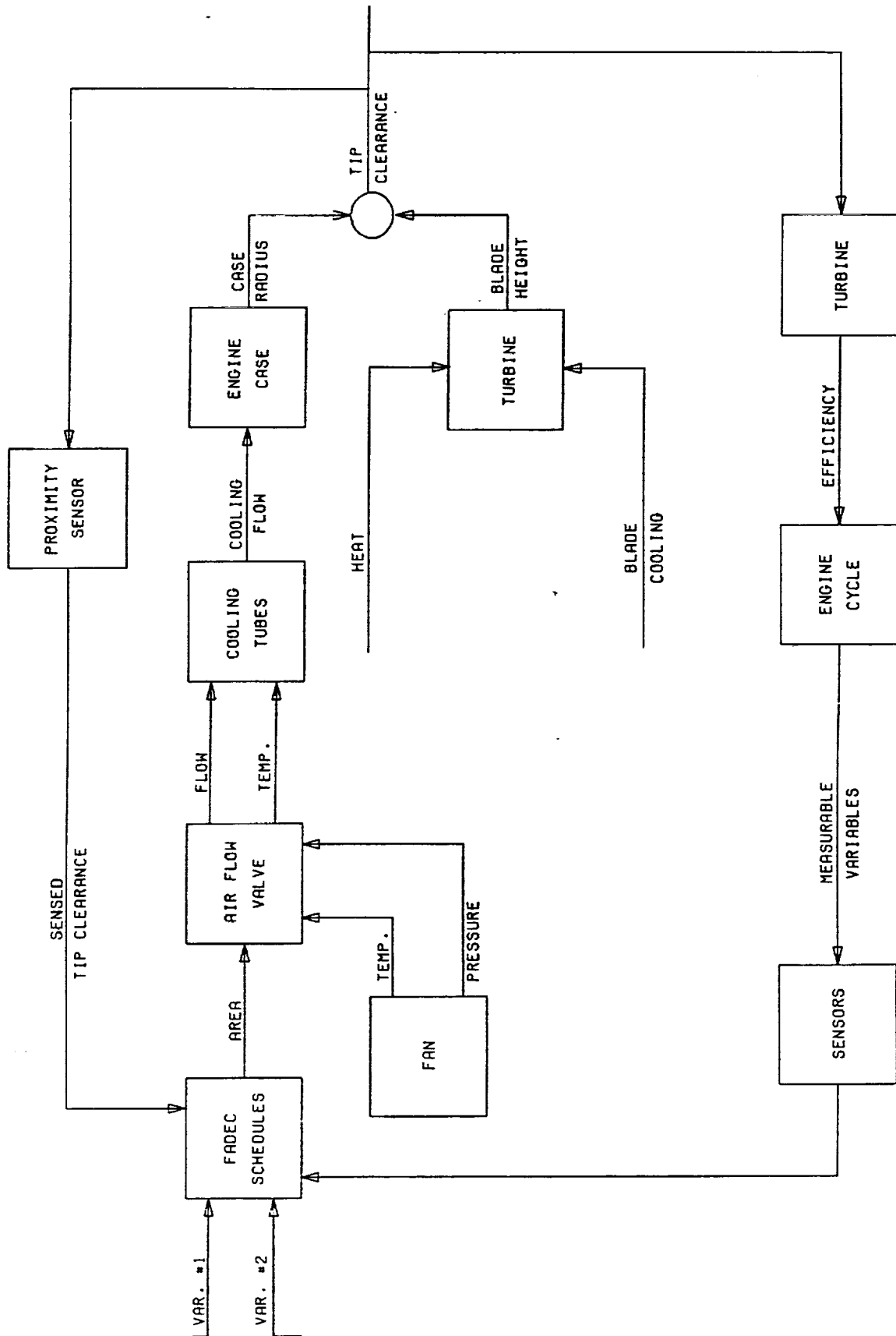

## ACTIVE AFTERBURNER RUMBLE SUPPRESSION

Rumble is a low frequency instability, fed by the combustion process, that occurs in mixed-flow afterburners in turbofan engines. Rumble occurs mainly at high fuel-air ratios and at flight conditions where low duct inlet air temperature and pressure exists (upper left corner of the flight envelope). Rumble causes 30 to 200 hertz pressure oscillations, normally 50 to 80 hertz, that usually lead to afterburner blowout and/or fan surge and engine stall.

Rumble characteristics are effected by engine design parameters and airflow and combustion dynamics. Redistribution of the fuel-to-air mixture ratio, and deriching the fan duct combustion reduces the rumble severity. Subtle changes in flameholder design and exhaust nozzle conditions alter rumble amplitudes and blowout characteristics. These engine design and airflow dynamic variations along with tolerances in fuel system scheduling, fuel distribution, fuel pressure regulation and fuel type (vaporization pressure) introduce considerable variation in rumble onset and severity. Current afterburner control system bias fuel-air ratio schedules to accommodate worst case expected combination of tolerances. Rumble is eliminated for worst case, but nominal and better engines are unnecessarily deriched. Thrust, and aircraft acceleration rate, are derated. A closed loop, active rumble system would not derich afterburner fuel-air ratio until an acceptable rumble amplitude threshold was exceeded. Derichment would be limited to the level necessary to prevent unacceptable rumble amplitudes.

An active afterburner rumble suppression system would begin with the addition of several high frequency pressure transducers (compared to current engine pressure sensors). The sensed pressure oscillations associated with rumble would be processed and provided to the FADEC. The processing would provide rumble pressure oscillation amplitude, oscillation frequency and pressure rate-of-change, and a rumble variable. The rumble variable would be a continuous indicator of rumble severity; varying from zero (0) in the absence of rumble up to full scale (100%) at the blowout/stall level. A threshold level of the rumble variable would be determined bases on acceptable rumble oscillations. The measured rumble variable would be compared with the threshold value, and scheduled fuel-air ratio would be down trimmed. Trimming would maintain the rumble variable at or below the threshold value at all engine and aircraft conditions; permitting maximizing afterburner thrust.

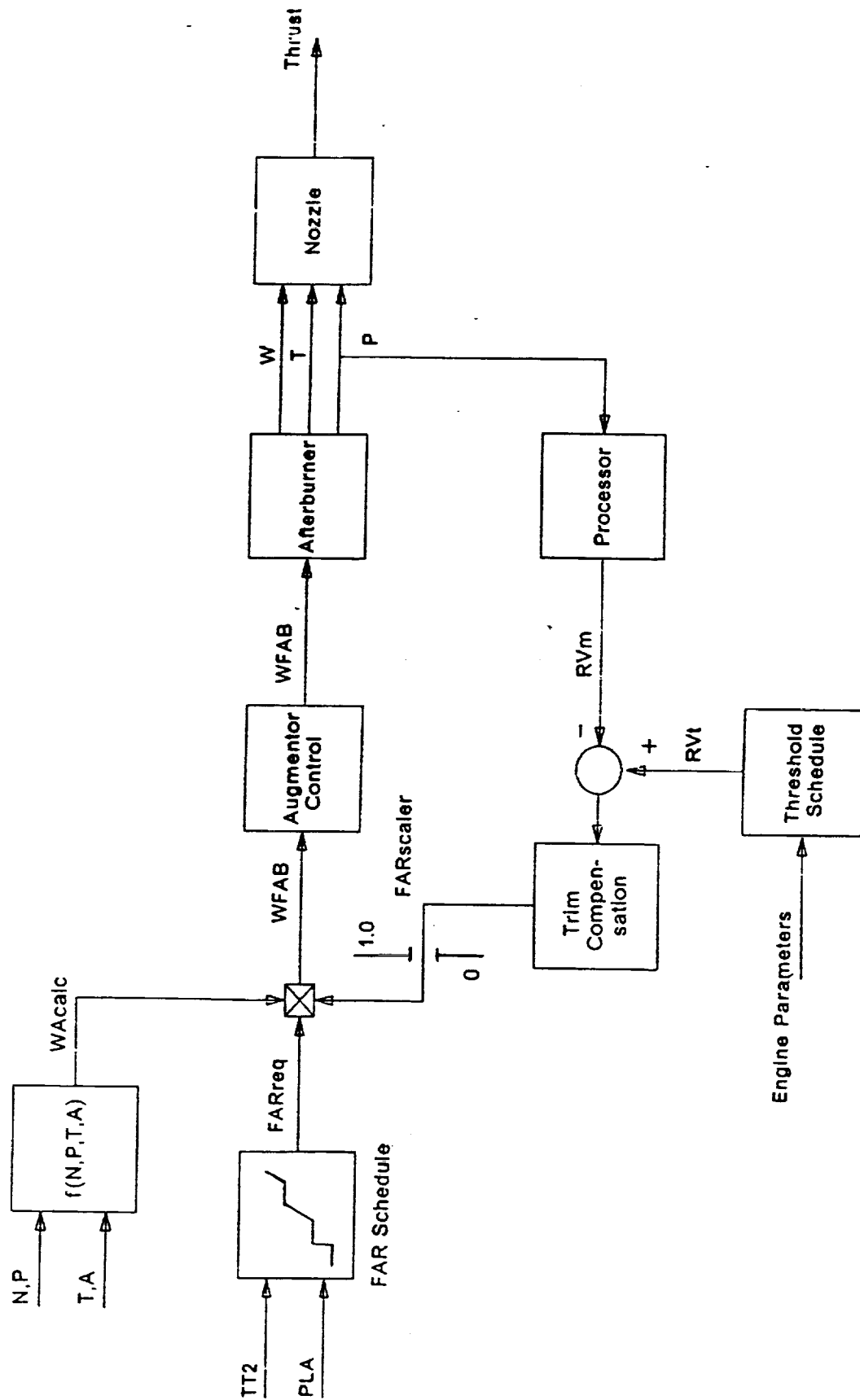

AFTER BURNER RUMBLE SUPPRESSION DIAGRAM

## PERFORMANCE SEEKING/MAINTAINING CONTROL

In conventional systems, engine mode and variable geometry scheduling is a compromise between performance, extended-life and stability. The compromise is a function of operating condition and is based on expected transient and maneuver requirements. Studies of integrated flight and propulsion control systems have shown that large improvements in aircraft system performance are possible by adjusting schedules based on the constraints of a particular mission segment. For instance during cruise, stability requirements may be traded for improved fuel consumption or extended-life. Initially these system improvements were achieved with predefined schedules based on simulation studies. However, recent studies indicate that additional improvements are possible with real-time adaptive schedules utilizing engine and aircraft models.

Normally, engine performance deterioration is a slow process resulting from wear and oxidation of the aerodynamic components and the secondary flowpath seals. Severe and rapid deterioration, however, can occur due to hardware failures, foreign object damage, and battle damage.

The Performance Seeking/Maintaining Control would include a parameter estimator that employs a Kalman filter, along with a State Variable Model (SVM). In this formulation system variables which are known to vary with time are included explicitly in the model, updated periodically using the estimation technique, and communicated to the control system which utilizes this information to accommodate off-nominal system behavior. The parameter estimator and its companion SVM identifies the level of key performance factors based on available instrumentation. Deviation estimates are supplied to an onboard model. The onboard model incorporates the effect of these deviations in the engine performance predictions in conjunction with aircraft performance models also employed with the in-flight algorithm. The model may be executed as part of a real-time aircraft optimization and as an onboard flight trajectory optimization. Outputs of the engine model may include both measured control variables such as engine temperatures, speeds, and pressures and unmeasured performance integration parameters such as airflow and thrust.

The benefits of a Performance Seeking/Maintaining Control are improved optimization of the combined aircraft/engine system for increased acceleration, higher penetration speed, reduced fuel consumption and increased payload. Optimum performance would be maintained for gradually deteriorated engine life, and safe operation if severe and rapid deterioration occurs. The control system is inherently adaptive and can accommodate engine-to-engine variations, aircraft aerodynamics configuration and aircraft loading.

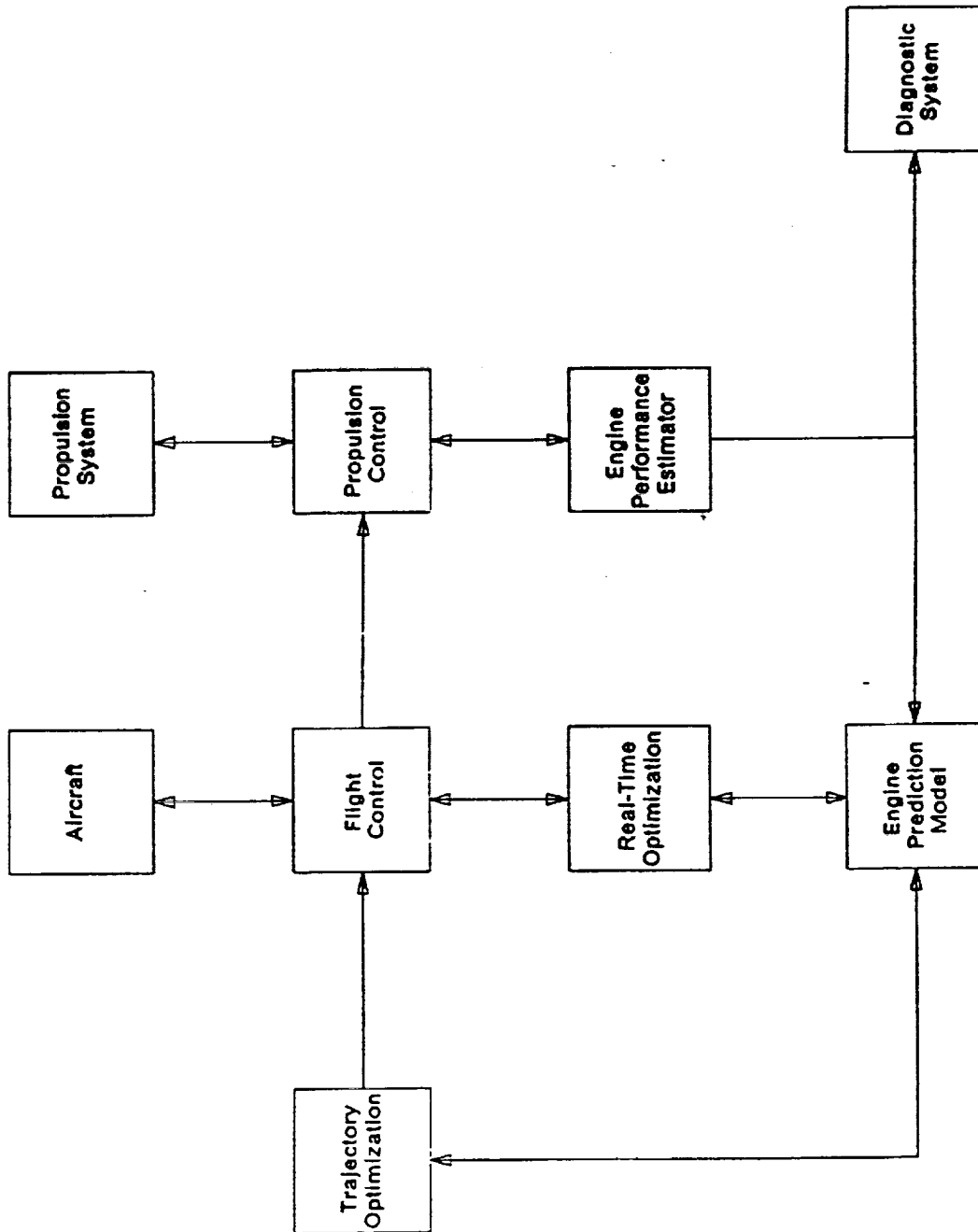

PERFORMANCE SEEKING / MAINTAINING CONTROL

## INTELLENT ENGINE CONTROL

Current turbine engine control modes and logic are designed to allow safe and stable engine operation under all conditions, included the most extreme. Variable compression system geometry and jet area have been controlled to meet steady-state requirements. As a results of accommodating worst case conditions, margins are excessive at most other operating conditions and engine performance capability is degraded. Engine thrust could be increased or compressor weight could be decreased if the high pressure compressor stall margin were reduced.

The intelligent control incorporates subsystems such as a real time engine model, an on-line surge line estimator, a high response multi-variable control and a performance optimizer. The intelligent control will integrate these subsystems to enhance engine operability and performance, allow engine operation with reduced margins, provide thorough, accurate fault diagnosis, control mode selection for optimized control response, analytical redundancy for sensor failure accommodation, and battle damage accommodation.

Pratt & Whitney has been developing, and is continuing to develop the subsystems required for the intelligent engine control. Multi-variable controls and self-tuning real time engine models have been developed for IR&D studies. A performance seeking control algorithm has been developed for the highly integrated digital electronic control (HIDEC) program. Rapid advances in digital electronics will allow the incorporation and integration of these and other control technologies into integrated flight propulsion controls to ensure attainment of the full potential of propulsion system performance.

Pratt & Whitney shall integrate the subsystems into an intelligent control functional architecture; then demonstrate each of the features using nonlinear engine simulations.

Comments from the paper "A Reusable Rocket Engine Intelligent Control" written by Merrill and Lorenzo of NASA. Their definition of an intelligent control includes that coordination and execution levels based on the principal of increasing precision with decreasing intelligence. The control framework contains life extending control, adaptive control, real-time engine diagnostics and prognostics, component condition monitoring, real-time identification, and sensor/actuator fault tolerance.

The framework provides top-down basis for incorporation through hierarchical integration at the execution level:

- High-speed -- closed-loop traditional controllers
- Engine diagnostics and adaptive reconfiguration
- Top level -- coordination/interface with aircraft/mission requirements

# CONTROL OF THE FUTURE

## ON-BOARD ENGINE MODEL IS KEY TO ADDITIONAL CAPABILITY

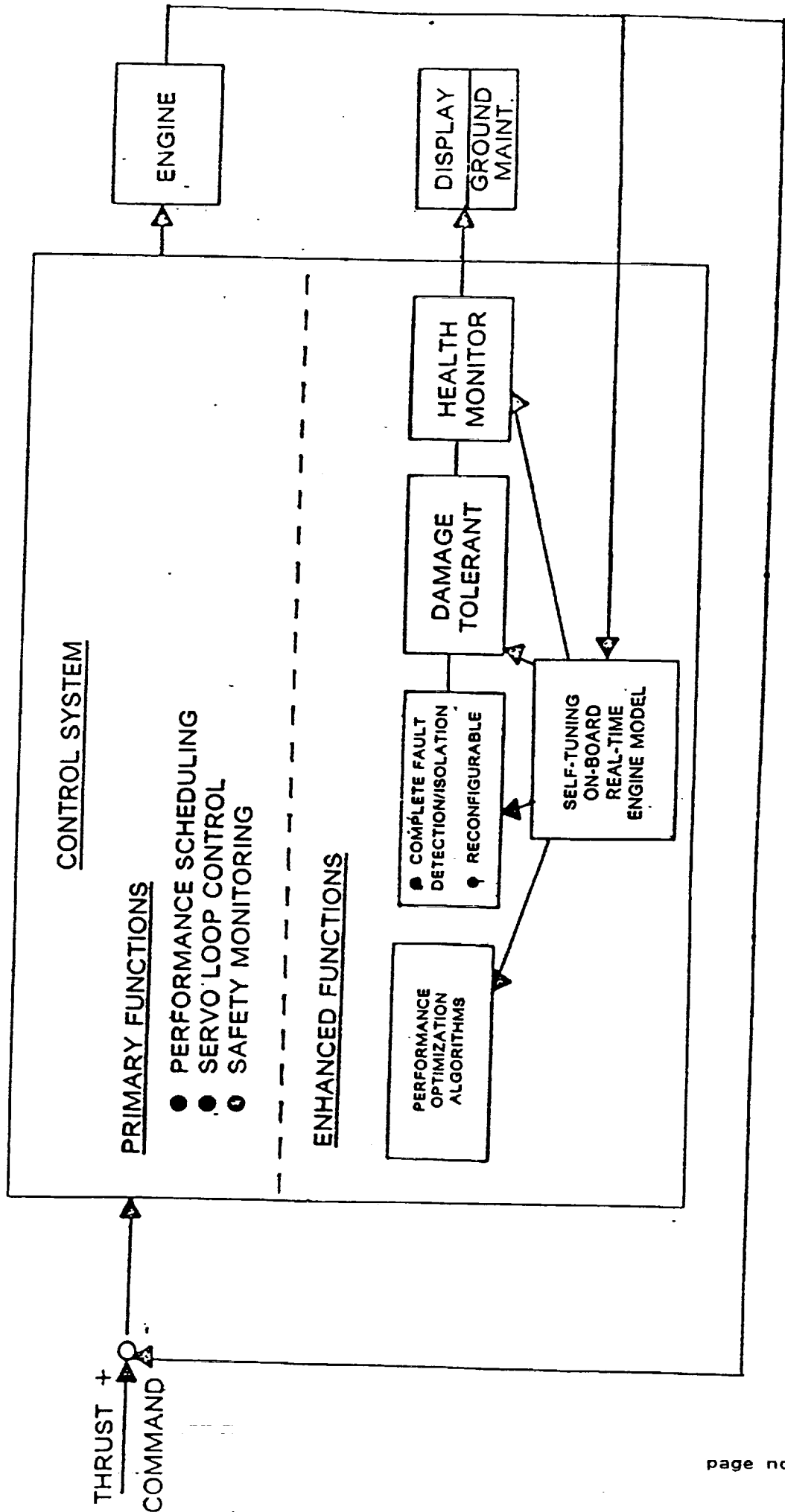



# INTELLIGENT ENGINE CONTROL PROVIDES ENHANCED SYSTEMS INTEGRATION

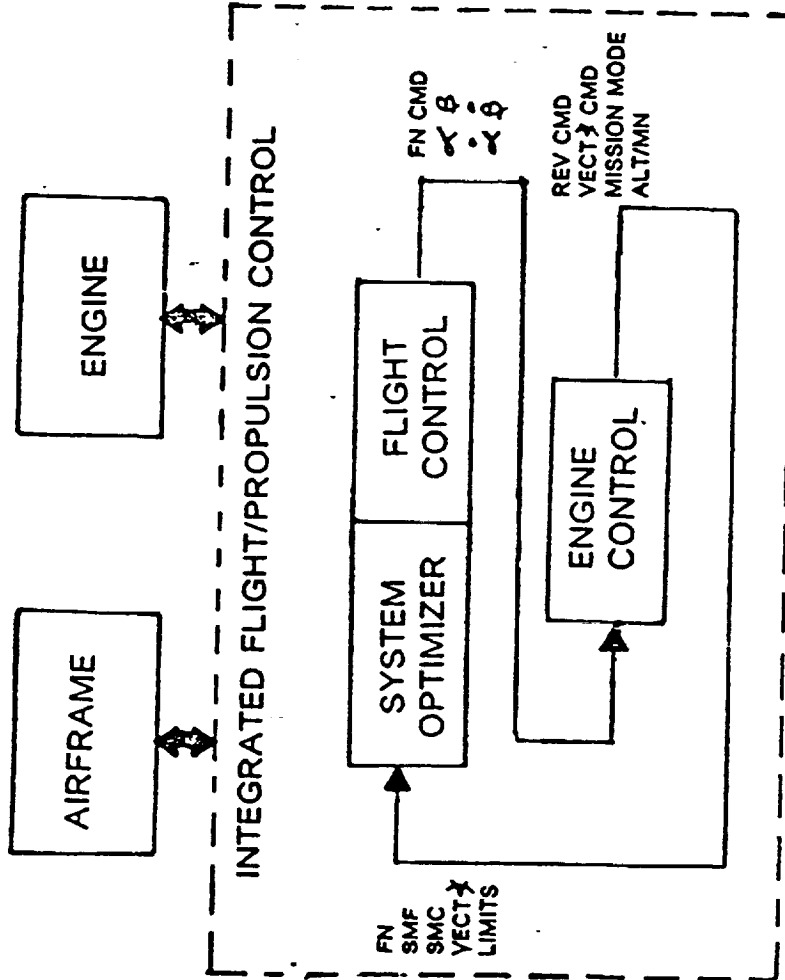

## IMPROVED STARTING (ACTIVE FUEL NOZZLE STAGING)

Combustion systems for modern turbofan engines are required to operate at ever-increasing levels of combustor temperature rise, or fuel-air ratio, without generation of objectionable levels of smoke. The control of smoke at increased fuel-air ratio typically requires higher levels of combustor primary or front end air flow to avoid rich combustion at high power. Unfortunately, these increased levels of combustor front end air flow adversely affects lean blowout and altitude relight capability. Staged fuel nozzles, wherein the total engine fuel flow is injected through only a portion of the fuel nozzles, are being used to provide local enrichment in the combustor to improve lean blowout and relight characteristics. The passive staging, currently employed uses distribution valves in the individual nozzles. Below a threshold pressure drop, with its overall fuel flow rate, metered fuel flow is delivered to unstaged nozzles only. At lightoff, all fuel flow is diverted to the bottom half of the engine to effectively double the local fuel-air ratio. At high power, when turbine inlet temperature is high, the fuel nozzles must flow uniformly to provide the uniform combustor exit temperature distribution necessary for turbine life.

The passive staging system has proven effective in current turbofan engines, but in more advanced applications the flight envelopes have become so large that the fuel flow for high power, high altitude, low flight Mach number points is approaching the sea level lightoff fuel flow. Thus, operation is required at the same low fuel flow rate in both uniform and staged modes. Passive staging on the basis of nozzle flow rate or pressure drop is no longer feasible. An active fuel nozzle staging system, wherein the transition from uniform to staged fuel distribution occurs at constant overall fuel-air ratio regardless of total fuel flow ratio, is needed. The proposed concept will enable the application of staged fuel nozzles and their attendant advantages in improved relight capability and avoidances of decel lean blowout to advanced engines.

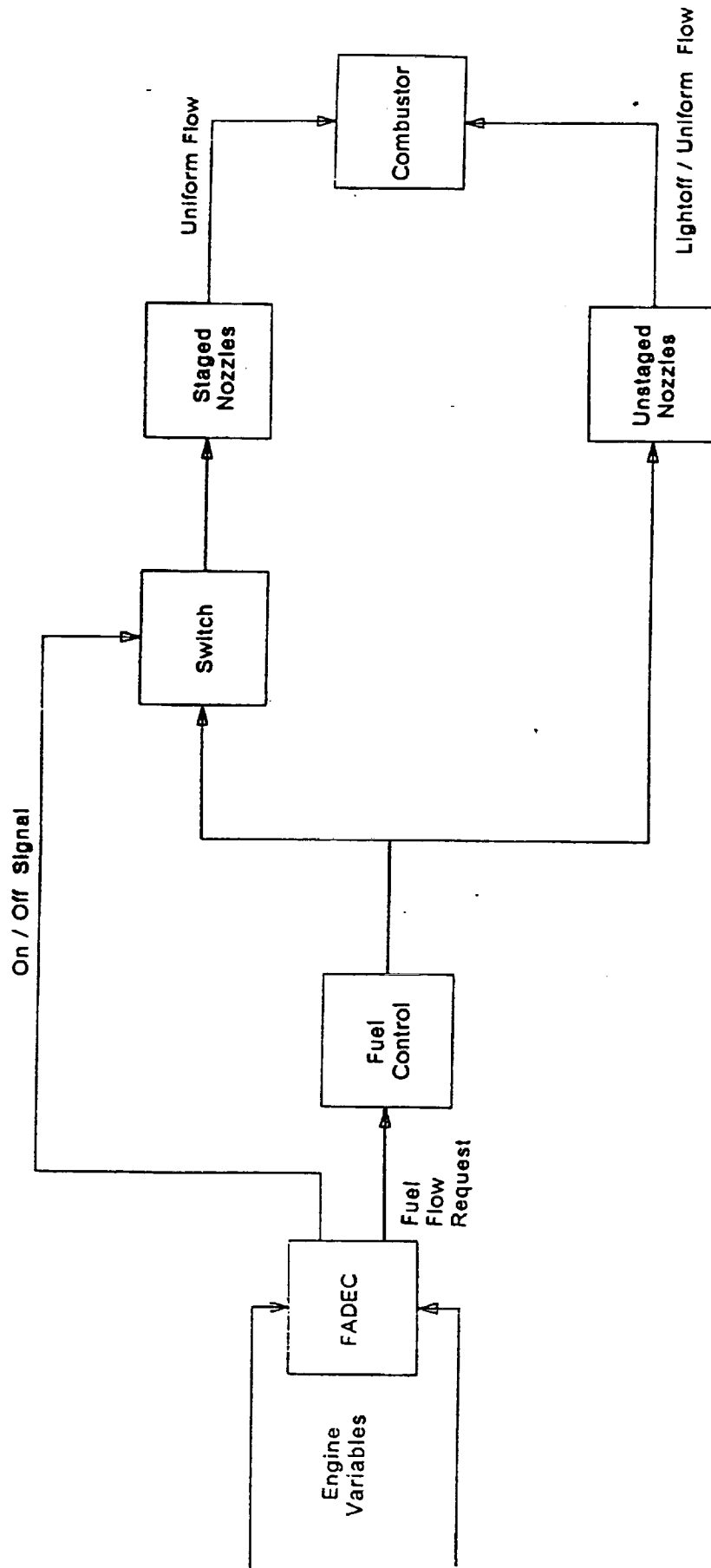

ACTIVE FUEL NOZZLE STAGING

## AUGMENTOR CONTROL SYSTEM IMPROVEMENTS

### Augmentor Flow Scheduling.

Augmentation is initiated through a power level command. This mode will be locked out during vertical land mode. The three (3) zone augmentor sequencing valves are scheduled based on a fuel/air ratio. The scheduling of the augmentor control logic has been upgraded to limit the minimum fuel/air ratio to a calculated stability parameter and to implement a fuel/air ratio optimizer. The optimizer will determine the optimum fuel/air ratio for a flight condition, engine deterioration and mechanical inaccuracies. The logic adjusts a flow parameter up or down until an optimum fuel/air ratio is obtained. The optimizer will achieve the maximum thrust for the aircraft thus avoiding too rich fuel/air ratios which would result in lower thrust and hotter nozzle exhaust temperature.

### Enhanced Partial Augmentor Fuel Flow Distribution.

During partial augmentation, current control systems sequence from zone 1 to zone "N", operating each zone to maximum fuel/air ratio until the required partial A/B fuel flow is attained. The scheduling approach penalizes partial A/B performance by producing a very non-uniform temperature profile in the exhaust nozzle. Significant improvements in part power A/B performance can be achieved if the necessary fuel flow is uniformly delivered to all zones so as to "flatten out" the nozzle inlet temperature profile. Scheduling would be dependent on the flame stability characteristics of the augmentor, i.e., the degree of uniformity achievable would vary with flight point so as to maintain combustion.

A P P E N D I X B

DETAILED DESCRIPTIONS OF PHASE II CONCEPTS

Control Concept -----	Page No. -----
Active Stall Control	B1
Stability Seeking Control	B5
Performance Seeking Control	B10
Intelligent Engine Control	B15

# ACTIVE AUGMENTOR FUEL/AIR SCHEDULING

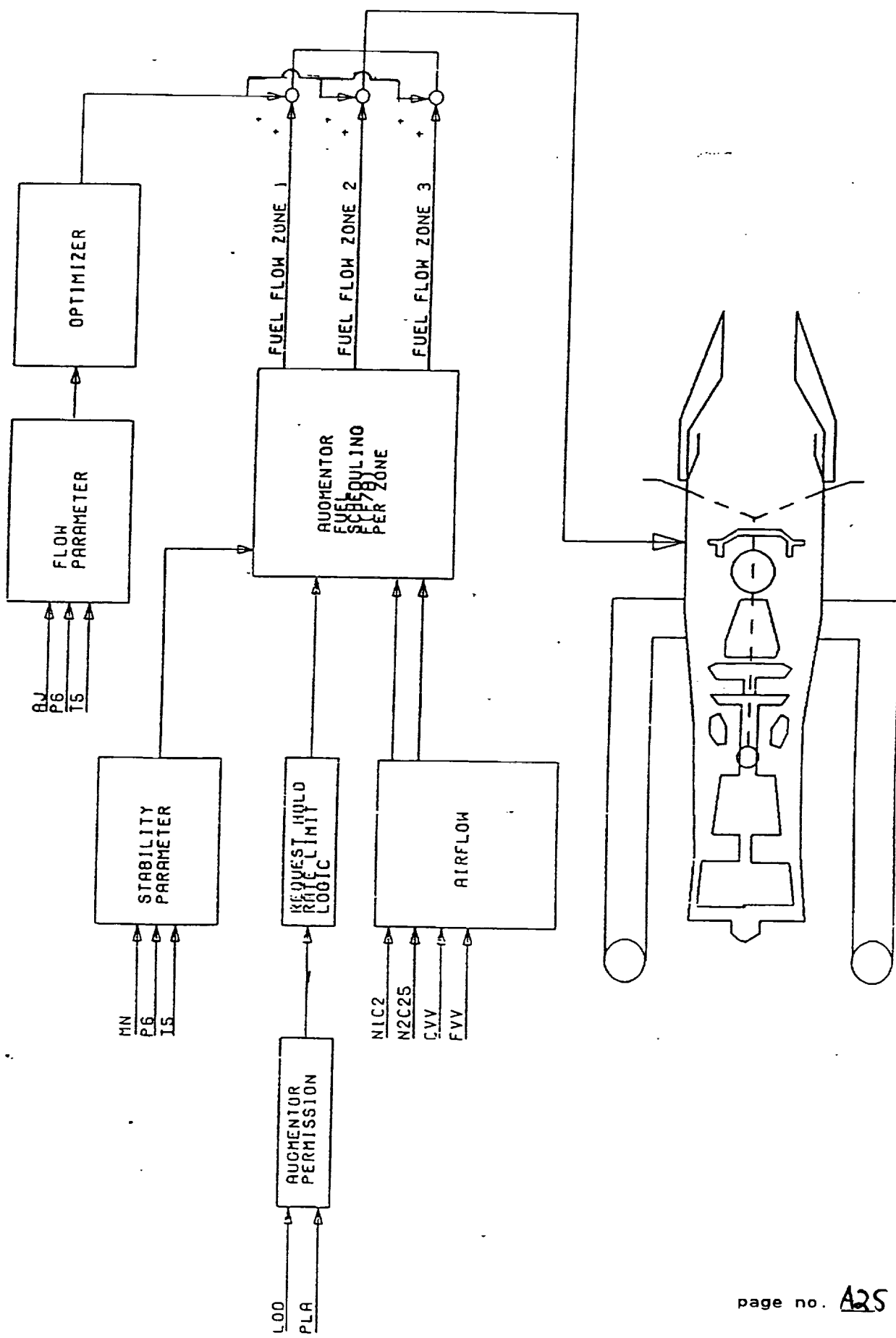

## a. Rationale for the Concept.

Current engine systems successfully use the control effectors to maintain adequate compression system aerodynamic stability margin to accommodate all destabilizing influences that may be encountered within the operational envelope. Destabilizing influences include Reynolds number effects, engine-to-engine variations and inlet distortion that lower the Fan or High Pressure Compressor surge lines, while augmentor sequencing backpressure perturbations, control tolerances and control upmatch raise the operating lines. Adequate component base surge margin is insured by rigorous upfront definition of the engine's stability and operability requirements. Current control methodology accommodates the destabilizing factors by designing schedules that account for the worst case of each of these factors at various flight conditions. This design philosophy, although effective, provides sufficient margin for the worst case scenario even when not needed and in the process, performance is sacrificed.

The Stability Seeking Control (SSC) will potentially reduce the required component design stability margin, while increasing compression system performance during favorable engine flight conditions; increasing engine thrust-to-weight ratio while reducing specific fuel consumption. The SSC schedules control effectors in response to sensed variations in engine or aircraft destabilizing influences and provides additional margin when needed.

## b. Control Block Diagram.

See separate page.

## c. Hardware Requirements.

- No addition sensors or actuators are required for the SSC.
- Increased processing is required for the SSC, but will reside within the existing Full Authority Digital Electronic Control (FADEC). Significant characteristics of the FADEC are:

The processor consists of two channels: each channel containing one of two interchangeable engine-mounted digital control units. The control operates in a dual active mode; each control is provided with its own input parameter set and output functions. Each channel shall be designed to be fail-passive such that a failure in one channel cannot precipitate a failure in the other channel. The dual active control simultaneously utilized both channels with equal authority.

The controller hardware requirements are:

Processor Architecture: The control has four processors-- one Input/Output Controller, one Data Management Processor and two Control Law Processors.

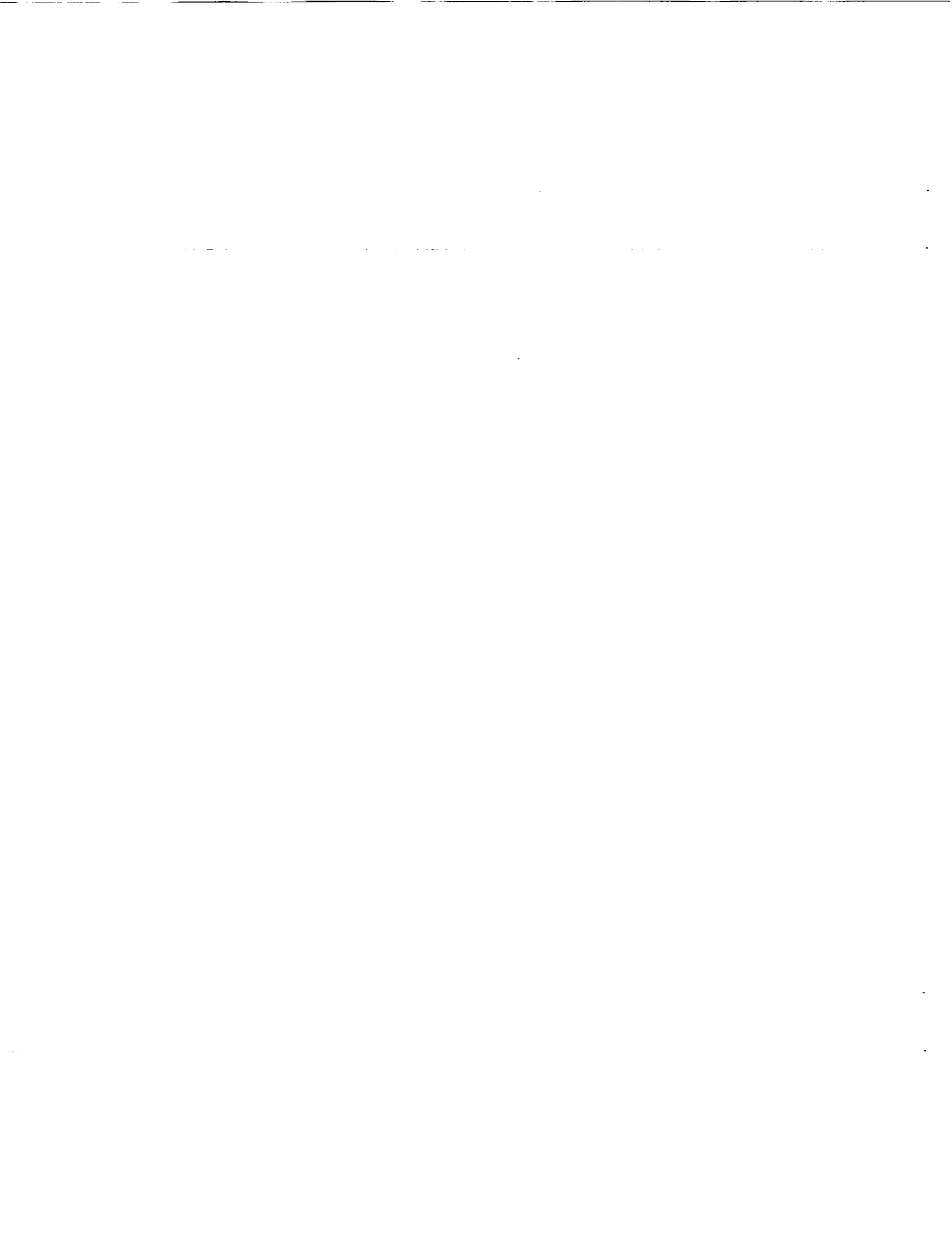



# STABILITY SEEKING CONTROL

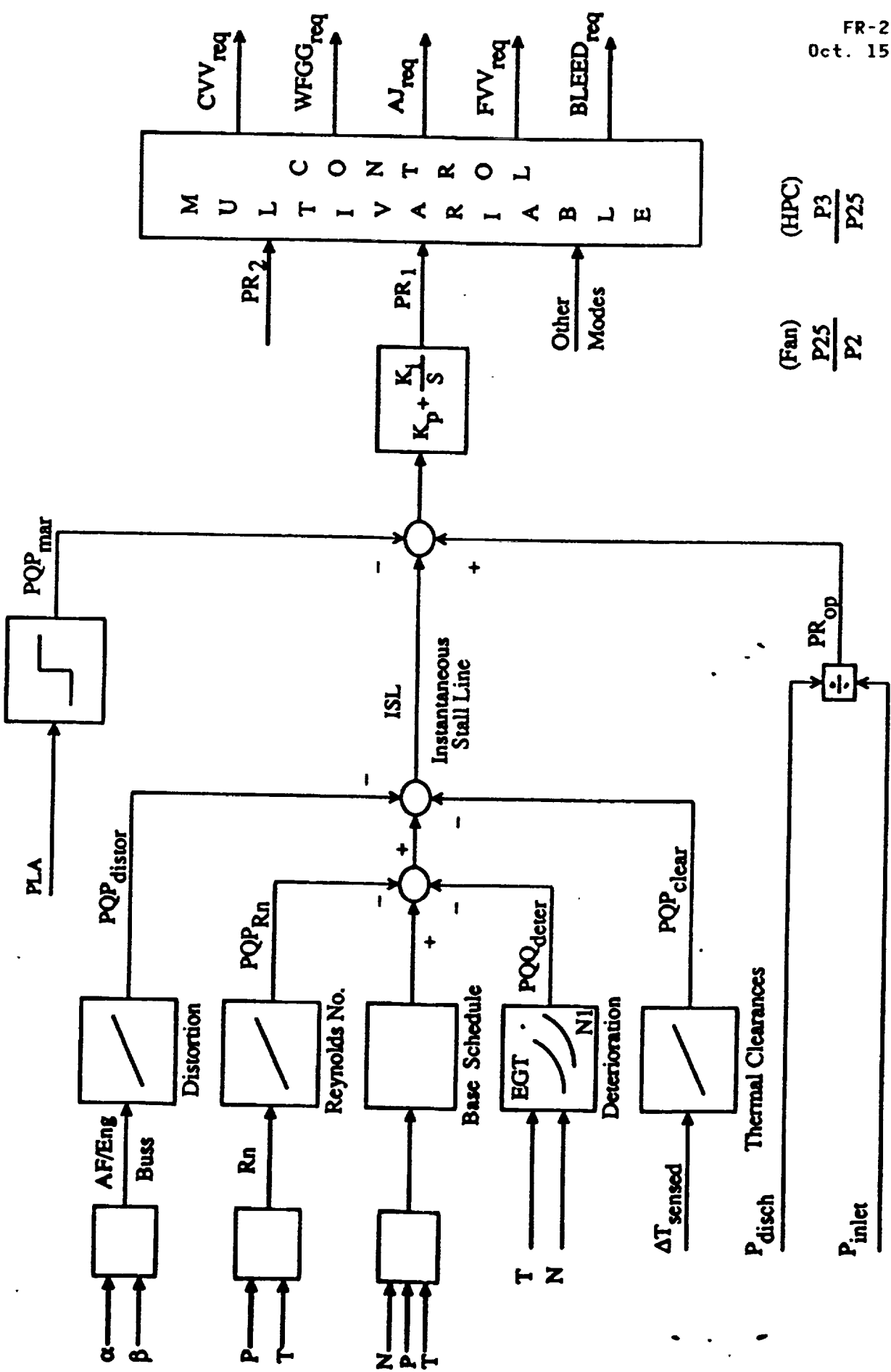

(Fan)  $\frac{P25}{P2}$   
(HPC)  $\frac{P3}{P25}$

**Control Law Processor:** Redundant main control processors with independent logic are provided. The CLP is designed with 68020 microprocessors, capable of running at 20 MHz and meeting the requirements of the Software Requirements Specification, for the Control Laws. The minimum throughput is 2.2 MIPS.

**Synchronization:** Control system synchronization is controlled by the Data Management Processor.

**Operational Software:** All operational software is programmed in the ADA program language.

**Built In Test:** The control incorporates testability features to support the following BIT functions: Initialization BIT executed upon initialization, and Real Time BIT to monitor I/O integrity.

**Memory:** Processor storage memory comprises of non-volatile Programmable Read Only Memory (PROM) devices. Production and pre-production units are programmable without disassembly by means of the DMP or IOC MIL-1553 interfaces. Development units may use ultra-violet erasable PROM, provided the devices are programmable at the board level without requiring removal from printed wiring/surface mounted assemblies. The minimum memory capacity for the processors consists of 410K bytes of program storage, 76K bytes of RAM and 26K bytes of EEPROM.

**Serial Data Communications:** Each control contains 10 serial data communication paths: 5 simplex MIL-STD-1553 data buses, dual 1 MEGAbaud Manchester link to the other control and two bidirectional UARTs.

**Dual Port RAM:** Data transfers between processors shall be via Dual Port RAM. Each dual port RAM memory has a minimum of 4K bytes for a total of 12K bytes.

The controller software requirements are:

The SSC Computer Software Configuration Item (CSCI) will be installed in the FADEC where it will interface with the existing Input/Output Controller (IOC) and the Control Laws (CL). The SSC CSCI will receive inputs from both the IOC and the CL and the outputs go to the CL CSCIs.

The SSC CSCI will exist in four distinct states; Power Off, Power Up, Control Active (Initialization Mode, Flight Mode, Initialized Built In Test Mode), and Maintenance (Initialization Mode and Monitor Support Mode).

**Timing Requirement:** The addition of the SSC CSCI to the baseline FADEC shall not jeopardize the modified software completing major cycle processing within 150 milliseconds and minor cycle processing within 12.5 milliseconds, by consuming a small portion of the 33 percent margin of the base-

Sizing Requirements: The SSC CSCI shall consume less than 10 percent of the baseline software package's memory growth margin; 170K bytes of UVPROM, 13.6K bytes of EEPROM and 16.4K bytes of RAM.

d. Implementation Time Frame.

Tasks

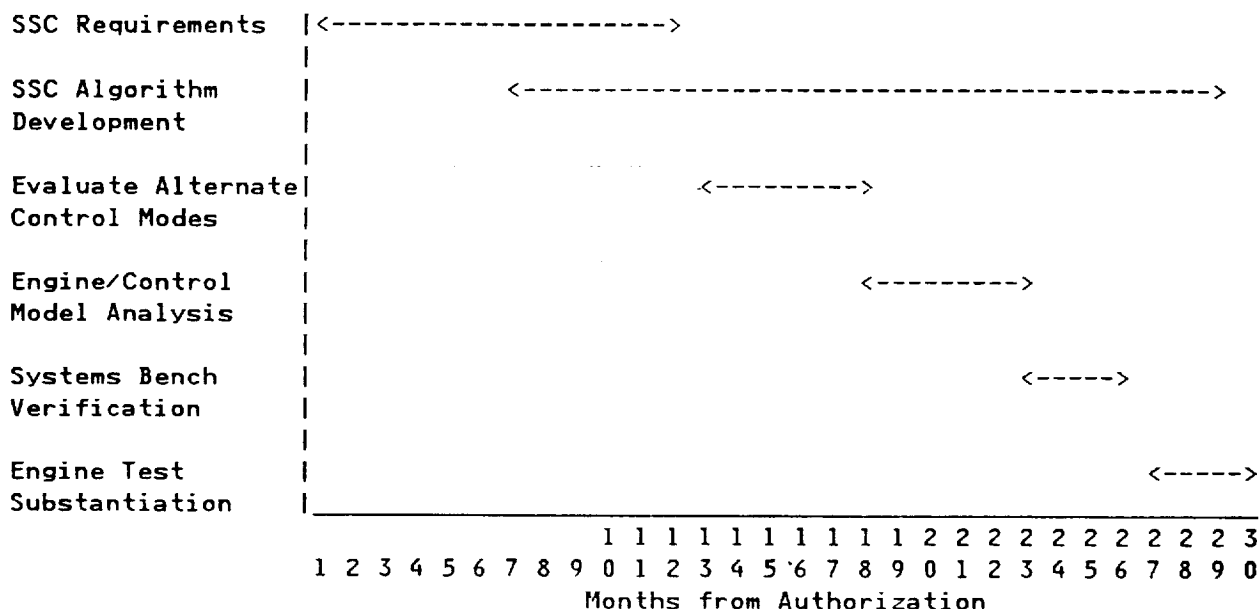

e. Critical Steps.

- Define and develop stability audit requirements for a stability seeking control. The definition includes the requirements for validation of the SSC control modes within a simulation environment, including flight condition, engine usage and external disturbances. Several conditions will be selected.
- Define control system requirements and design the control algorithms. Develop a multivariable control system computer model, compatible with a transient engine model. The control system design includes gains and scheduling for the entire flight envelope operation.
- Develop algorithms to perform an on-line stability audit to be executed within the engine control model. Included are effects on stall pressure ratio and operating pressure ratio for the following:
  - \* Aircraft angles of attack and sideslip
  - \* Deterioration
  - \* Steady-state and transient compressor blade tip clearance
  - \* Transient heat storage
  - \* Flight condition (Reynolds Number)

\* Combustor bleed and power extraction

- Alternative control modes for transient operation that minimize fan and HP compressor operating line excursions, while maintaining operability characteristics similar to current systems will be investigated and evaluated.
- Baseline engine/control models will be run at the specified test conditions to determine the component stall margin requirements. Improvements in component stall margins and operability characteristics will be evaluated by running the engine/SSC at the same test conditions.
- Requirements for an engine validation of the control algorithms shall be determined and a program test plan shall be generated.
- SSC algorithms shall be validated by loading the logic into a controller installed on a real time engine/control system bench.
- SSC algorithms shall be substantiated by installing the controller containing the SSC algorithms on a developmental test engine, and executing the prepared engine test program.

## a. Rationale for the Concept.

Turbomachinery achieve optimum performance when operated near its maximum pressure ratio. Unfortunately, stall with unstable flow conditions exists at the optimum conditions. Stall margin must be provided by scheduling the engine controls. Current engine systems successfully use the control effectors to maintain adequate compression system aerodynamic stability margin to accommodate all destabilizing influences that may be encountered within the operational envelope. Destabilizing influences include Reynolds number effects, engine-to-engine variations and inlet distortion that lower the Fan or High Pressure Compressor surge line, while augmentor sequencing backpressure perturbations, control tolerances and control upmatch raise the operating lines. Adequate component base surge margin is insured by rigorous up-front definition of the engine's stability and operability requirements. Current control methodology accommodates the destabilizing factors by designing schedules that account for the worst case of each of these factors at each flight condition. This design philosophy, although effective, provides sufficient margin for the worst case scenario even when not needed and in the process, performance is sacrificed.

The Active Stall Control (ASC) will permit operation with reduced component design stability margin, beyond that available with Stability Seeking Control, by sensing impending surge and causing the control to reposition the control system effectors. The combination of ASC and SSC will reduce the impact of the destabilizing influence, while increasing compression system performance during favorable engine flight conditions; increasing engine thrust-to-weight ratio while reducing specific fuel consumption.

## b. Control Block Diagram.

See separate page.

## c. Hardware Requirements.

Additional high response pressure sensors and a high response processor are required for the ASC.

**Pressure Sensor Requirements.** The pressure sensors measure the absolute pressure in the fan or high pressure compressor. The sensors (Optical or Electrical small volume strain gauge) then convert the measurements into signals which are received by the control.

Excitation:	10.0 Vdc	(Electrical)
Sensor Output:	50 millivolts, +/- 0.5%.	(Electrical)
Pressure Range:	0 to 500 psia.	
Bridge Balance:	0. psia shall be within +/- 1% of full scale.	
Bridge Resistance:	I/O resistance to be 2500 ohms nominal.	
Accuracy:	+/- 0.5% of full scale at room temperature (including linearity, hysteresis and repeatability by RSS method).	
Response:	Faster than an equivalent 1st order response with a lag time constant of .001 second.	

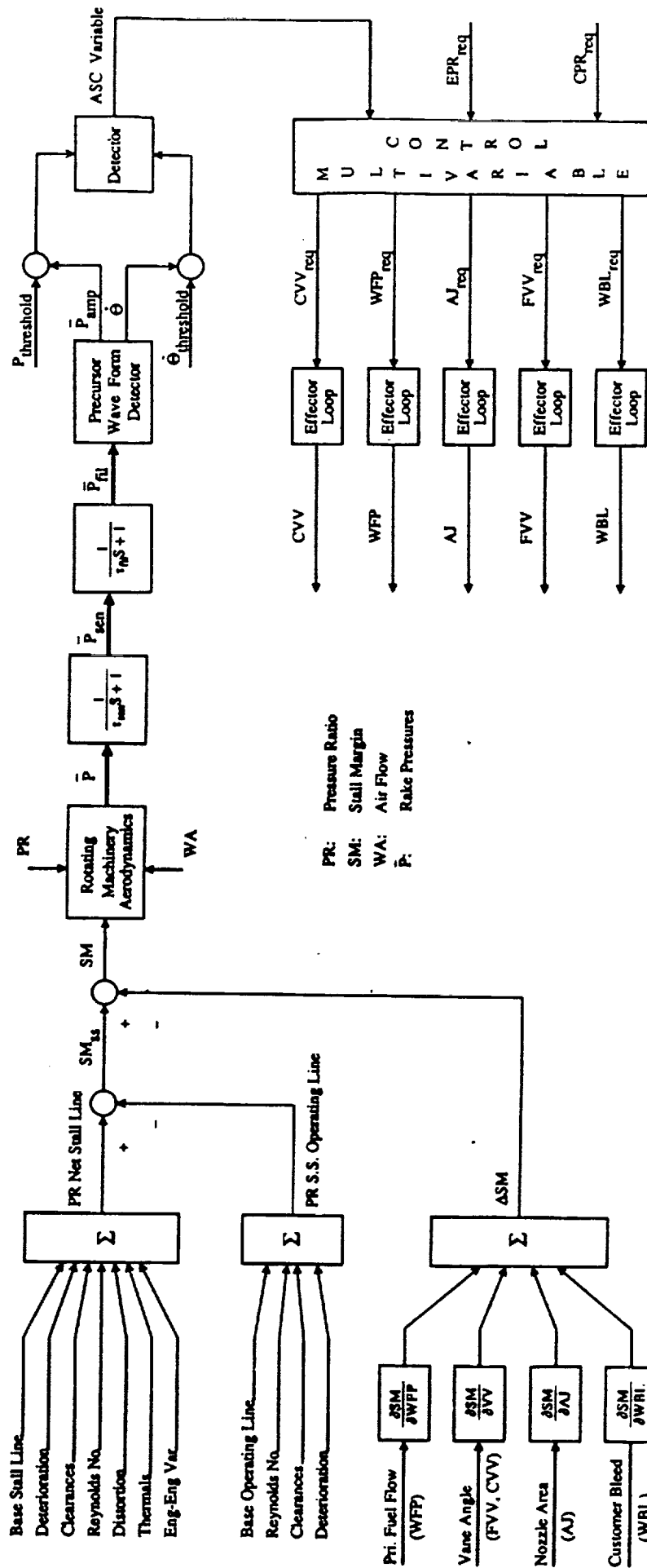

PR: Pressure Ratio  
SM: Stall Margin  
WA: Air Flow  
P: Rake Pressures

ACTIVE STABILITY CONTROL DIAGRAM

-- High speed pressure data processing (Electrical or Optical) is required for the ASC.

Description: Eight high response pressure sensors are mounted in pressure rakes located in each of two planes around the outer walls of the high pressure compressor and the fan. Sensed pressure signals from the pressure measurement probes are supplied to the controller. The controller calculates rotating pressure waves phase angles, used as a stall precursor. The processor may be analog or fast digital for the electrical sensors or digital for the optical.

The requirements for the controller include:

Conversion Algorithm: To be Determined  
System Repeatability: " " " "  
System Accuracy: " " " "  
Input Voltage: +/- 15 VDC, 3.0 W (max)  
Output Voltage: 1.0 +/- 0.1 to 9.0 +/- 0.4 VDC  
with 100 ohms Impedance (max)  
Response: Faster than an equivalent 1st order response with a  
time constant of .001 seconds.

Purging and Cooling: Same as Base Engine Controllers  
Fluid Compatibility: " " " "  
External Leakage: " " " "  
Environmental: " " " "

For Digital Processing --

Architecture: contains I/O controller and control law processor  
Memory: as required to process the algorithms.  
Input/Output: 32 inputs and 2 outputs

Software for the Digital Processing --

Inputs: 32 dynamic pressures (16 for Fan and 16 for the HPC)  
Algorithms: 2 channels, Phase Angle for Fan and Phase Angle for HPC  
Update Rate: 400 passes per second

d. Implementation Time Frame.

Tasks

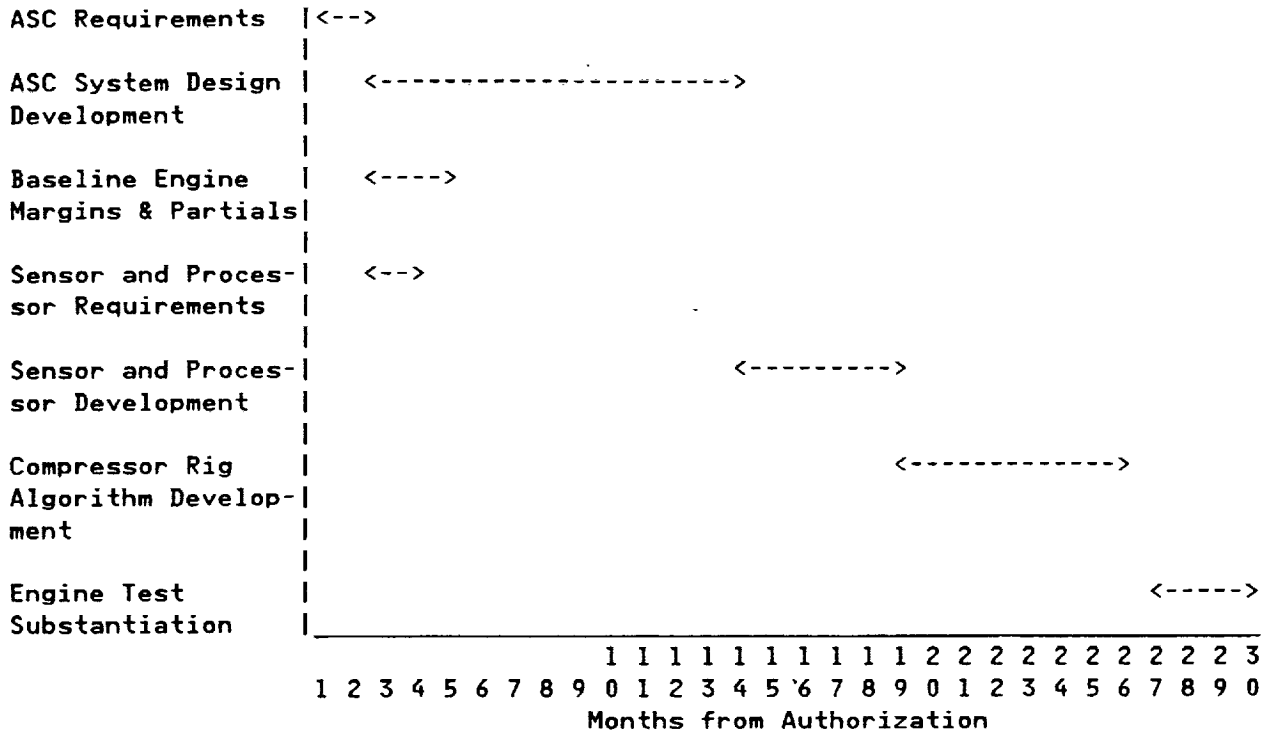

e. Critical Steps.

- Define and develop operational requirements for the Active Stability Control. The definition includes the requirements for validation of the ASC on the test rig and engine test substantiation.
- An ASC system will be designed for the existing Pratt & Whitney advanced Full Scale High Speed Research (FSHSR) three-stage compressor rig. A stall precursor signal has been identified and analyzed under a related Independent Research and Development (IR&D) program.
- High response pressure measurements on the baseline engine fan and HP compressor will be recorded during engine stall testing. Sensitivity of stall margins to controller outputs will be determined at various engine operating conditions. The ASC algorithm will reset appropriate controller effectors in response to the precursor.
- Unambiguous signals of the presence of rotating stall must be generated. When the precursor detects rotating stall control action must occur within the millisecond time frame, and its effect should be almost immediate. When no rotating stall is present, the control should have no effect on the compression system operation.



- Sensors and high response data processor may be developed by installing the sensors in a development engine inlet. The quieter ambient conditions will simplify development of the processing algorithm. Real-time measurement and processing may be verified prior to installation in the fan or HP compressor.
- ASC algorithm will be verified by installing the pressure rakes and processor containing the ASC algorithm on the FSHSR compressor rig. The system will actively monitor component performance, recognize the stall precursor signal, and act to downmatch the component slightly from its stall boundary.
- ASC algorithms will be substantiated by installing the pressure rakes and processor containing the ASC algorithms on a development test engine, and executing the prepared test program.

## a. Rationale for the Concept.

Performance Seeking Control (PSC) can improve steady-state performance of engine designs by on-line control calculations of performance-seeking algorithms to obtain maximum thrust or minimum fuel consumption. This concept is being demonstrated in the NASA-sponsored HIDEDEC Program, worked jointly with MCAIR. For a typical air superiority mission, 85% of flight time and 45% of fuel is spent during cruise, and 97% of the mission is conducted at steady-state operation conditions. Current turbofan engine control modes and logic are designed to provide safe and stable engine operation under all conditions, including worst case. As a result, control performance schedules are normally not at the optimum for best thermodynamic efficiency. Integrated flight and propulsion controls, coupled with an accurate onboard engine model, provide the necessary information to adjust the steady-state engine match, as well as engine inlet ramps and divergent flaps, on-line for the best fuel burn. The HIDEDEC Program predicts up to a 1.5 percent improvement during nonaugmented cruise and will be demonstrated in the PSC flight-test phase scheduled for mid-1990. For the F100-family PW1128 engines used in the flight test, studies show that about a 4-percent improvement in High Pressure Compressor (HPC) efficiency would have to be achieved for an equivalent benefit.

## b. Block Diagram.

See separate page.

## c. Hardware Requirements.

- No addition sensors or actuators are required for the PSC.
- Increased processing is required for the PSC, but will reside within the existing Full Authority Digital Electronic Control (FADEC). Significant characteristics of the FADEC are:

The processor consists of two channels: each channel containing one of two interchangeable engine-mounted digital control units. The control operates in a dual active mode; each control is provided with its own input parameter set and output functions. Each channel shall be designed to be fail-passive such that a failure in one channel cannot precipitate a failure in the other channel. The dual active control simultaneously utilized both channels with equal authority.

- The controller hardware requirements are:

Processor Architecture: The control has four processors-- one Input/Output Controller, one Data Management Processor and two Control Law Processors.

Control Law Processor: Redundant main control processors with independent logic are provided. The CLP is designed with 68020 microprocessors, capable of running at 20 MHz and meeting the requirements of the Software Re-

PSC CONTROL LAW

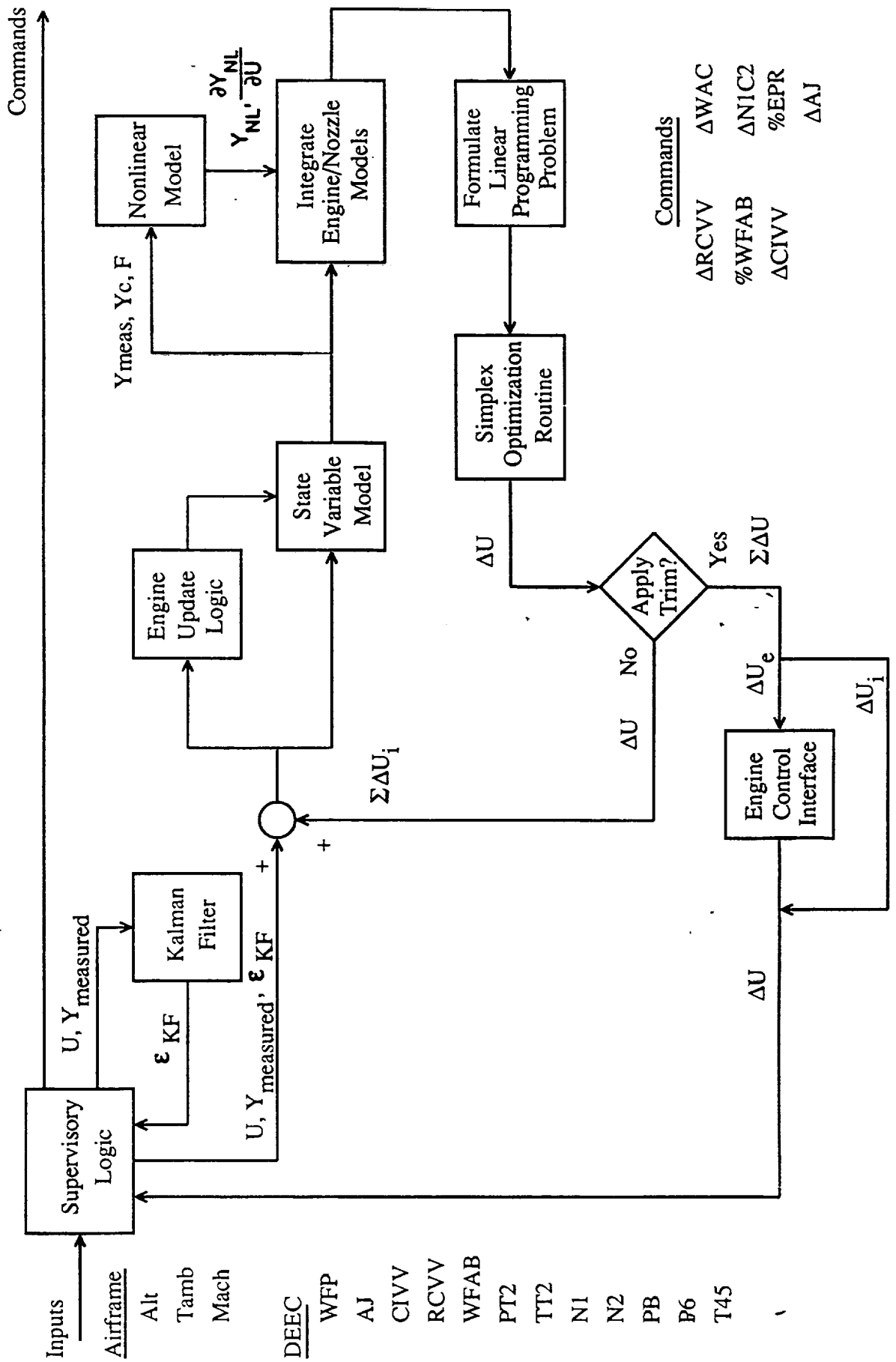

Commands  
 $\Delta RCVV$   $\Delta WAC$   
 $\%WFAB$   $\Delta NIC2$   
 $\Delta CIVV$   $\%EPR$   
 $\Delta AJ$

quirements Specification, for the Control Laws. The minimum throughput is 2.2 MIPS.

**Synchronization:** Control system synchronization is controlled by the Data Management Processor.

**Operational Software:** All operational software is programmed in the ADA program language.

**Built In Test:** The control incorporates testability features to support the following BIT functions: Initialization BIT executed upon initialization, and Real Time BIT to monitor I/O integrity.

**Memory:** Processor storage memory comprises of non-volatile Programmable Read Only Memory (PROM) devices. Production and pre-production units are programmable without disassembly by means of the DMP or IOC MIL-1553 interfaces. Development units may use ultra-violet erasable PROM, provided the devices are programmable at the board level without requiring removal from printed wiring/surface mounted assemblies. The minimum memory capacity for the processors consists of 410K bytes of program storage, 76K bytes of RAM and 26K bytes of EEPROM.

**Serial Data Communications:** Each control contains 10 serial data communication paths: 5 simplex MIL-STD-1553 data buses, dual 1 MEGAbaud Manchester link to the other control and two bidirectional UARTs.

**Dual Port RAM:** Data transfers between processors shall be via Dual Port RAM. Each dual port RAM memory has a minimum of 4K bytes for a total of 12K bytes.

-- The controller software requirements are:

The PSC Computer Software Configuration Item (CSCI) will be installed in the FADEC where it will interface with the existing Input/Output Controller (IOC) and the Control Laws (CL). The PSC CSCI will receive inputs from both the IOC and the CL and the outputs go to the CL CSCIs.

The PSC CSCI will exist in four distinct states; Power Off, Power Up, Control Active (Initialization Mode, Flight Mode, Initialized Built In Test Mode), and Maintenance (Initialization Mode and Monitor Support Mode).

**Timing Requirement:** The addition of the PSC CSCI to the baseline FADEC shall not jeopardize the modified software completing major cycle processing within 150 milliseconds and minor cycle processing within 12.5 milliseconds, by consuming a small portion (less than 10%) of the 33 percent margin of the baseline software package.

**Sizing Requirements:** The PSC CSCI shall consume less than 10 percent of the baseline software package's memory growth margin; 170K bytes of UV PROM, 13.6K bytes of EEPROM and 16.4K bytes of RAM.

d. Implementation Time Frame.

Tasks

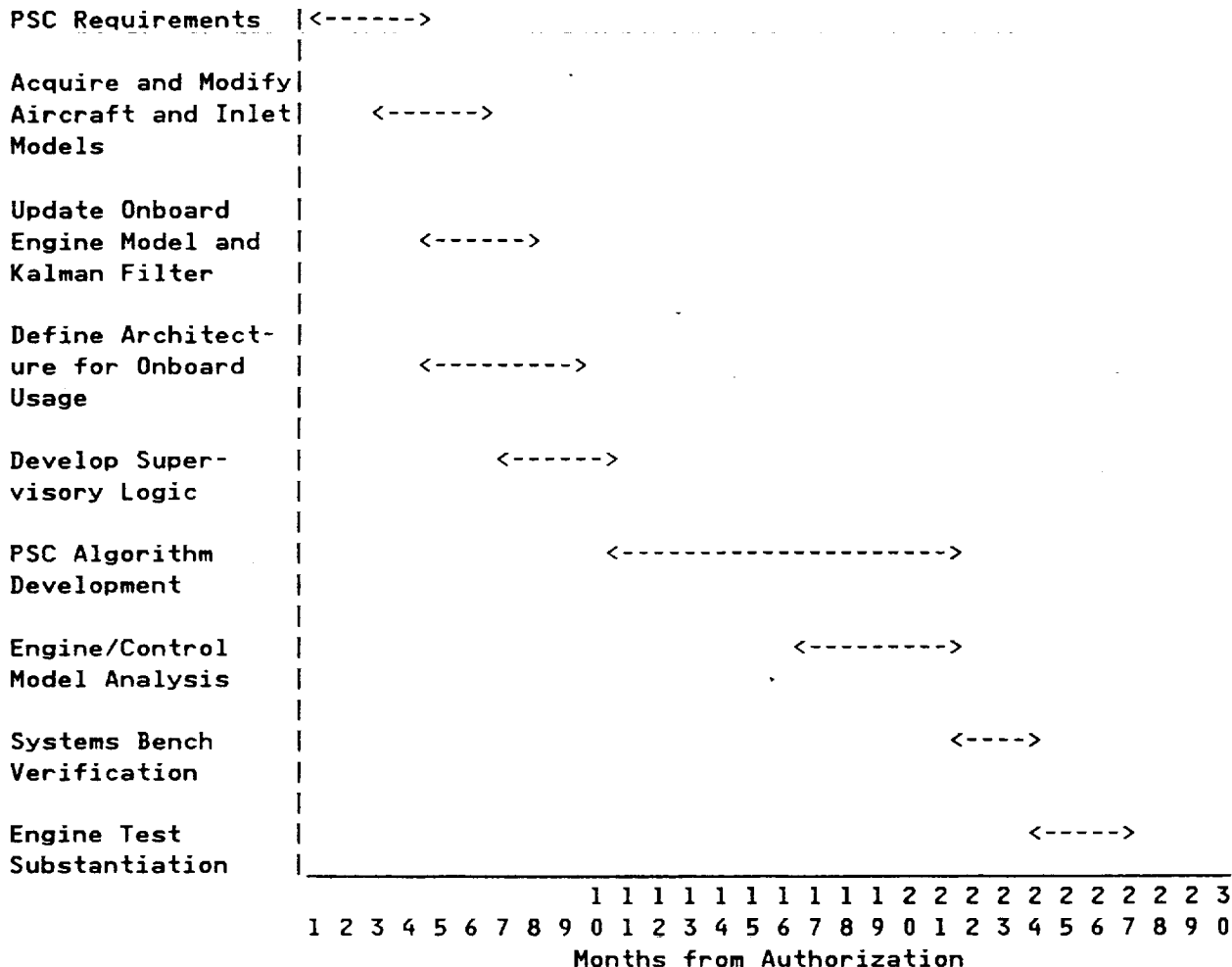

e. Critical Steps.

- Define and develop performance and operability improvement requirements for a performance seeking control. Optimization factors and operating conditions will be defined. The definition includes the requirements for validation of the PSC control modes within a simulation environment, including flight condition, power levels, engine usage and external disturbances. Several conditions will be selected.
- An accurate real-time engine model will be developed, enabling making on-line estimates of engine variables and parameters. The model makes a variety of optimization approaches possible. The model can be used to directly generate derivatives for linear and nonlinear gradient search procedures. The practical factors for optimization are predominantly engine-

related, such as stall margin, fuel consumption gross thrust and nozzle expansion ratio.

- The architecture integrating the several PSC system components will be defined. The hardware and software interfaces between the existing engine sensor/controller/effector components with the compact engine, inlet and nozzle models, along with the executive logic, supervisory logic and optimization logic will be connected by data busses and logic interfaces.
- Baseline engine/control models will be run at the specified test conditions to determine the engine performance improvement requirements for each selected mode. Improvements in engine performance and operability characteristics will be evaluated by running the engine/PSC at the same test conditions.
- PSC algorithms will be validated by loading the logic into a controller installed on a real time engine/control system bench. PSC algorithms will be substantiated by installing the controller containing the PSC algorithms on a developmental test engine, and executing the prepared engine test program.
- PSC algorithms will be substantiated by installing the controller containing the PSC algorithms on a flight test aircraft, and executing the prepared flight test program.

## a. Rationale for the Concept.

Control systems for today's aircraft gas turbines engines are typically designed with the same philosophy incorporated in hydromechanical control systems of the last decade. Previous control systems were limited in computational resources, allowing only a single operating mode. The control system schedules were generalized for the entire flight envelope, for all missions, and for the entire life of the engine, rather than being customized for a specific point, mission, or state of health. As a result, the engine did not achieve optimum performance at any time. Communications with the flight control was minimal in these systems, so the engine control had to ensure stable engine operation even in the worst-case aircraft maneuvering and inlet distortion conditions. This requirement, combined with control inaccuracy and a control mode designed primarily for maintaining steady-state performance, limited engine transient rates and small signal response capabilities. Additionally, this requirement dictated that the compression system components be designed with large amounts of stall margin (typically well above 20 percent). The excess stall margin requirements limited component performance, increasing the size and weight of the engines.

The inherent sensitivity of the control system to sensor failures required the designer to either accept the potential for serious degradation in system performance (including inflight shutdown) or to provide redundancy through either additional sensors or a backup control system. The most significant limitation of the hydromechanical systems was the absence of diagnostic capabilities - numerous maintenance man-hours were spent troubleshooting engine anomalies.

## b. Control Block Diagram.

Diagram shown on separate page

## c. Hardware Requirements.

- No addition sensors or actuators are required for the IEC.
- Increased processing is required for the IEC, but will reside within the existing Full Authority Digital Electronic Control (FADEC). Significant characteristics of the FADEC are:

The processor consists of two channels: each channel containing one of two interchangeable engine-mounted digital control units. The control operates in a dual active mode; each control is provided with its own input parameter set and output functions. Each channel shall be designed to be fail-passive such that a failure in one channel cannot precipitate a failure in the other channel. The dual active control simultaneously utilized both channels with equal authority.

FD 375238

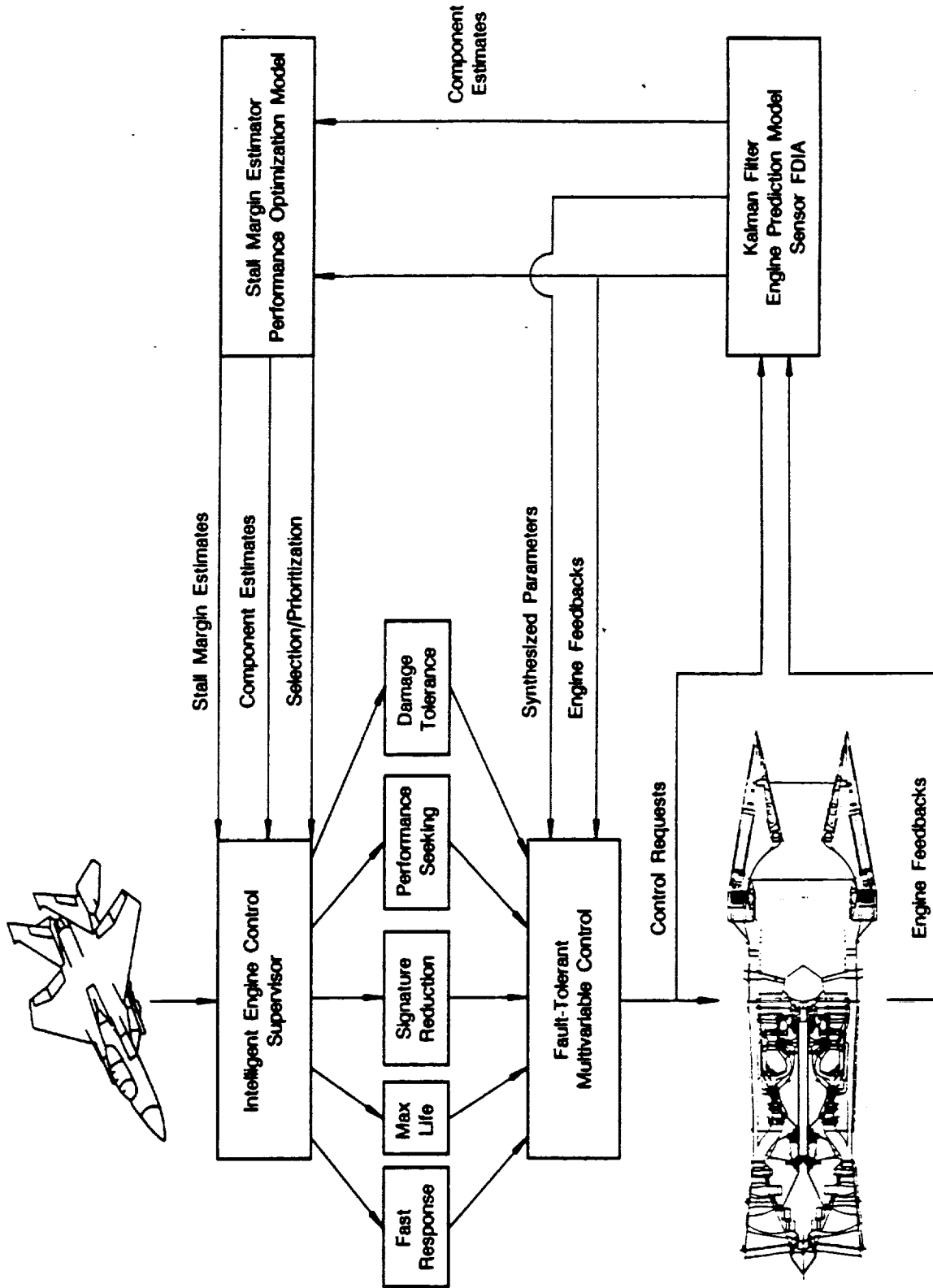
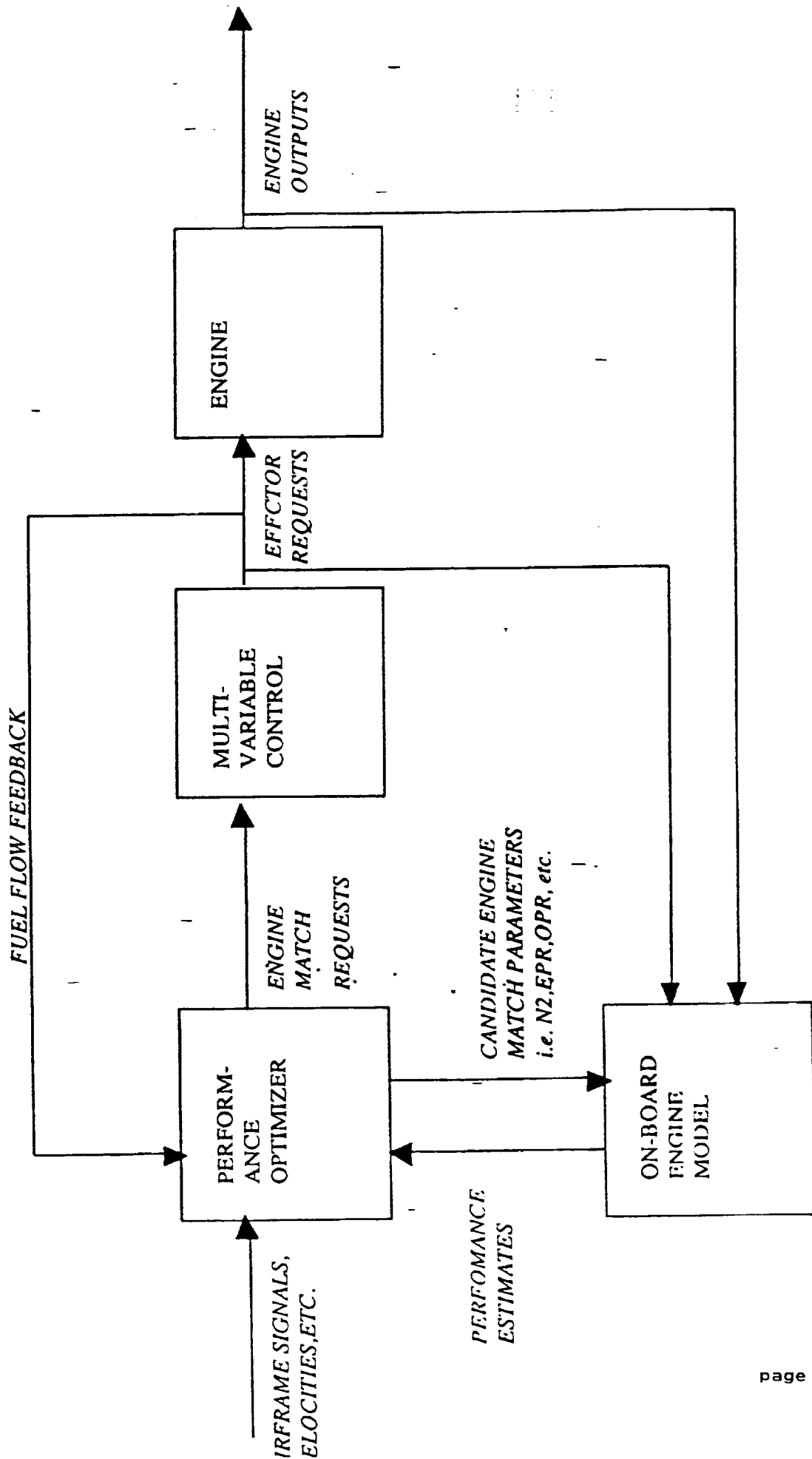

Figure 2-3. Intelligent Engine Control Architecture



# PERFORMANCE OPTIMIZING CONTROL MODE



# TYPICAL ON-LINE STABILITY AUDIT

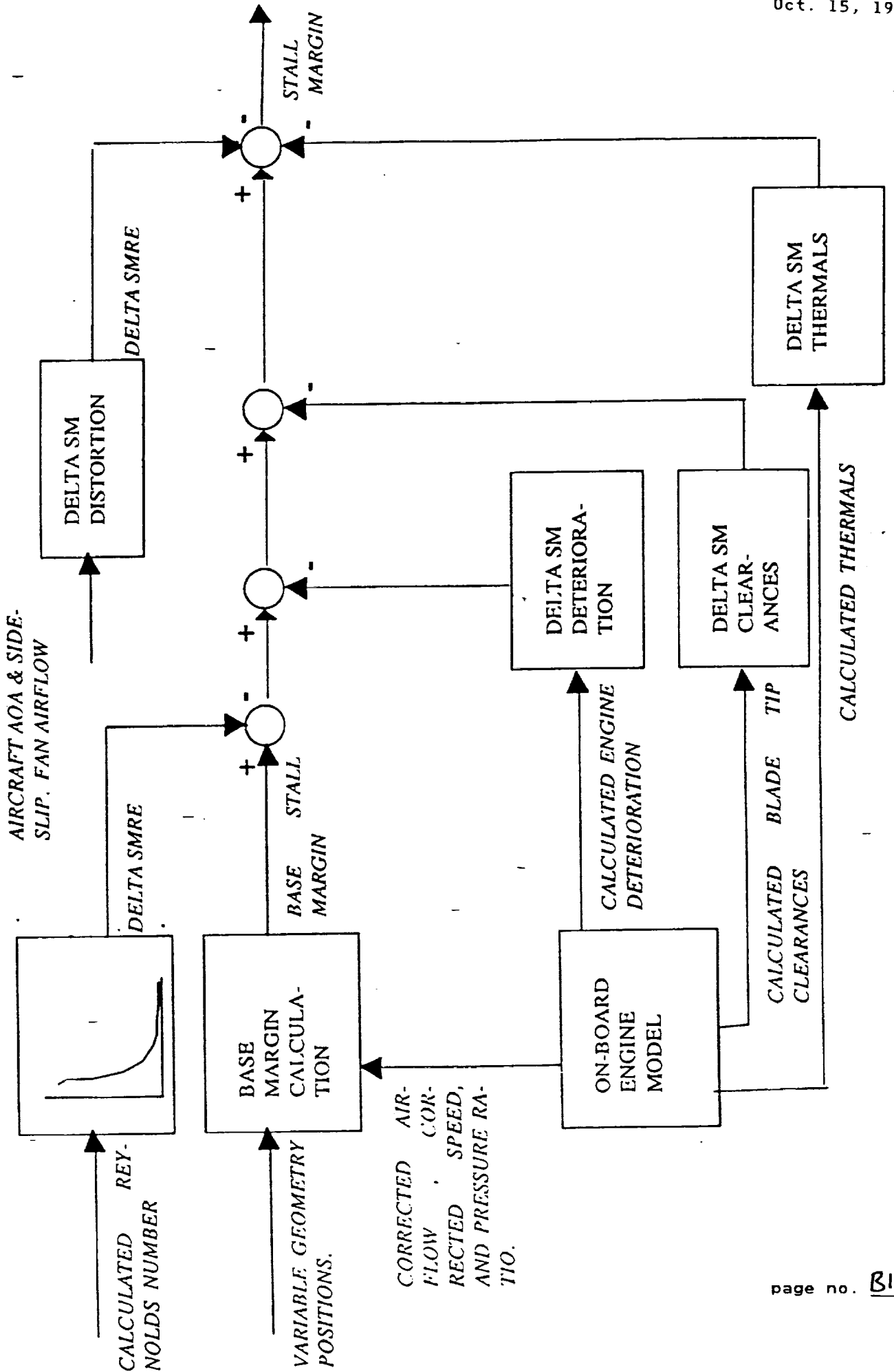

The controller hardware requirements are:

**Processor Architecture:** The control has four processors-- one Input/Output Controller, one Data Management Processor and two Control Law Processors.

**Control Law Processor:** Redundant main control processors with independent logic are provided. The CLP is designed with 68020 microprocessors, capable of running at 20 MHz and meeting the requirements of the Software Requirements Specification, for the Control Laws. The minimum throughput is 2.2 MIPS.

**Synchronization:** Control system synchronization is controlled by the Data Management Processor.

**Operational Software:** All operational software is programmed in the ADA program language.

**Built In Test:** The control incorporates testability features to support the following BIT functions: Initialization BIT executed upon initialization, and Real Time BIT to monitor I/O integrity.

**Memory:** Processor storage memory comprises of non-volatile Programmable Read Only Memory (PROM) devices. Production and pre-production units are programmable without disassembly by means of the DMP or IOC MIL-1553 interfaces. Development units may use ultra-violet erasable PROM, provided the devices are programmable at the board level without requiring removal from printed wiring/surface mounted assemblies. The minimum memory capacity for the processors consists of 410K bytes of program storage, 76K bytes of RAM and 26K bytes of EEPROM.

**Serial Data Communications:** Each control contains 10 serial data communication paths: 5 simplex MIL-STD-1553 data buses, dual 1 MEGAbaud Manchester link to the other control and two bidirectional UARTs.

**Dual Port RAM:** Data transfers between processors shall be via Dual Port RAM. Each dual port RAM memory has a minimum of 4K bytes for a total of 12K bytes.

The controller software requirements are:

The IEC Computer Software Configuration Item (CSCI) will be installed in the FADEC where it will interface with the existing Input/Output Controller (IOC) and the Control Laws (CL). The IEC CSCI will receive inputs from both the IOC and the CL and the outputs go to the CL CSCIs.

The IEC CSCI will exist in four distinct states; Power Off, Power Up, Control Active (Initialization Mode, Flight Mode, Initialized Built In Test Mode), and Maintenance (Initialization Mode and Monitor Support Mode).

**Timing Requirement:** The addition of the IEC CSCI to the baseline FADEC shall not jeopardize the modified software completing major cycle proces-

sing within 150 milliseconds and minor cycle processing within 12.5 milliseconds, by consuming a small portion (less than 20 %) of the 33 percent margin of the baseline software package.

Sizing Requirements: The IEC CSCI shall consume less than 20 percent of the baseline software package's memory growth margin; 170K bytes of UVPR0M, 13.6K bytes of EEPROM and 16.4K bytes of RAM.

d. Implementation Time Frame.

Tasks

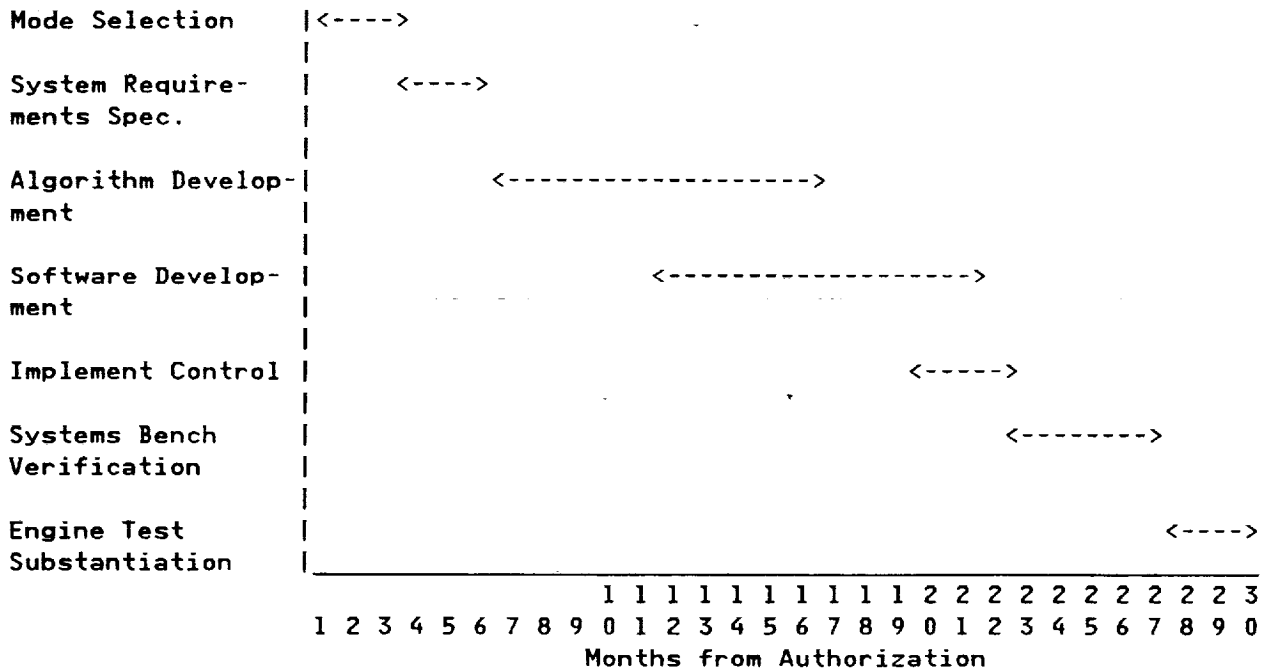

e. Critical Steps.

- Review and assess candidate advanced control modes for their benefits and suitability for incorporation into Intelligent Engine Control. Stability Seeking Control and Performance Seeking Control modes were included in the preliminary phase. Additional modes may include Mission Adaptive mode and Combat Rating Mode.
- An accurate real-time engine model will be developed, enabling making on-line estimates of engine variables and parameters. The model makes a variety of optimization approaches possible. This model can be used to direct-
- The critical steps required to design and develop a Stability Seeking Control will be completed.

- The critical steps required to design and develop the Performance Seeking Control will be completed.
  
- Real-time bench software verification and engine substantiation testing will be completed in accordance with the carefully written test plans. Testing will evaluate the effects and interaction of multiple parameters. The planned tests will be performed on the system simulation to evaluate success criteria and data recording requirements.

**REPORT DOCUMENTATION PAGE**Form Approved  
OMB No. 0704-0188

Public reporting burden for this collection of information is estimated to average 1 hour per response, including the time for reviewing instructions, searching existing data sources, gathering and maintaining the data needed, and completing and reviewing the collection of information. Send comments regarding this burden estimate or any other aspect of this collection of information, including suggestions for reducing this burden, to Washington Headquarters Services, Directorate for Information Operations and Reports, 1215 Jefferson Davis Highway, Suite 1204, Arlington, VA 22202-4302, and to the Office of Management and Budget, Paperwork Reduction Project (0704-0188), Washington, DC 20503.

<b>1. AGENCY USE ONLY (Leave blank)</b>		<b>2. REPORT DATE</b> July 1993	<b>3. REPORT TYPE AND DATES COVERED</b> Final Contractor Report	
<b>4. TITLE AND SUBTITLE</b> Advanced Controls for Airbreathing Engines Volume 1 Pratt & Whitney			<b>5. FUNDING NUMBERS</b>  WU-505-62-61 C-NAS3-25952	
<b>6. AUTHOR(S)</b>  J.A. Ralph				
<b>7. PERFORMING ORGANIZATION NAME(S) AND ADDRESS(ES)</b>  United Technologies, Inc. Pratt & Whitney P.O. Box 109600 West Palm Beach, Florida 33410-9600			<b>8. PERFORMING ORGANIZATION REPORT NUMBER</b>  E-8006	
<b>9. SPONSORING/MONITORING AGENCY NAME(S) AND ADDRESS(ES)</b>  National Aeronautics and Space Administration Lewis Research Center Cleveland, Ohio 44135-3191			<b>10. SPONSORING/MONITORING AGENCY REPORT NUMBER</b>  NASA CR-189203	
<b>11. SUPPLEMENTARY NOTES</b>  Project Manager, Peter J. Ouzts, Instrumentation and Control Technology Division, (216) 433-6469.				
<b>12a. DISTRIBUTION/AVAILABILITY STATEMENT</b>  Unclassified - Unlimited Subject Category 07			<b>12b. DISTRIBUTION CODE</b>	
<b>13. ABSTRACT (Maximum 200 words)</b>  The application of advanced control concepts to airbreathing engines may yield significant improvements in aircraft/engine performance and operability. Screening studies of advanced control concepts for airbreathing engines have been conducted by three major domestic aircraft engine manufacturers to determine the potential impact of concepts on turbine engine performance and operability. The purpose of the studies was to identify concepts which offered high potential yet may incur high research and development risk. A target suite of proposed advanced control concepts was formulated and evaluated in a two phase study to quantify each concept's impact on desired engine characteristics. To aid in the evaluation specific aircraft/engine combinations were considered: a Military High Performance Fighter mission, a High Speed Civil Transport mission, and a Civil Tiltrotor mission. Each of the advanced control concepts considered in the study are defined and described. The concept potential impact on engine performance was determined. Relevant figures of merit on which to evaluate the concepts are determined. Finally, the concepts are ranked with respect to the target aircraft/engine missions. A final report describing the screening studies has been prepared by each engine manufacturer. Volume 1 of these reports describes the studies performed by Pratt & Whitney.				
<b>14. SUBJECT TERMS</b>  Controls			<b>15. NUMBER OF PAGES</b> 79	
			<b>16. PRICE CODE</b> A05	
<b>17. SECURITY CLASSIFICATION OF REPORT</b> Unclassified	<b>18. SECURITY CLASSIFICATION OF THIS PAGE</b> Unclassified	<b>19. SECURITY CLASSIFICATION OF ABSTRACT</b> Unclassified	<b>20. LIMITATION OF ABSTRACT</b>	