

N 9 4 - 1 3 7 4 4**STUDY ON THE MECHANISM OF LIQUID PHASE SINTERING
M-12****S. Kohara
University of Tokyo
Tokyo, Japan****Description of the Project****Objectives:**

(1) To obtain the data representing the growth rate of solid particles in a liquid matrix without the effect of gravity.

(2) To reveal the growth behavior of solid particles during liquid phase sintering using the data obtained.

Background of the Experiment:

Sintering means the particle coalescence of a powdered aggregate accomplished by heating at an elevated temperature. When a powdered aggregate composed of two kinds of constituent metals is heated and kept at a temperature higher than the melting point of one constituent metal, the metal with the lower melting point melts down and forms a liquid phase. Sintering is accelerated by the existence of a liquid phase compared to the sintering in a solid phase. This technique in powder metallurgy is called liquid phase sintering.

The properties of sintered products are dependent on the size distribution of the second phase particles. However, the solid particles in a liquid matrix grow larger during sintering. Therefore, it is important to reveal the growth behavior of the solid particles during sintering to

control the properties of sintered products in industrial applications. However, the study on the growth behavior of solid particles during liquid phase sintering is difficult on Earth because of the gravitational segregation of solid particles.

In the present experiment, nickel and tungsten are used as the constituent materials in liquid phase sintering. The properties of the constituent metals are given in Table 1. When a compact of the mixture of tungsten and nickel powders is heated and kept at 1550 °C, nickel melts down but tungsten stays solid. As the density of tungsten is much greater than that of nickel, the sedimentation of tungsten particles occurs in the experiment on Earth. Figure 1 illustrates the difference between the experiments on Earth and in space. The tungsten particles sink to the bottom and are brought into contact with each other. The resulting pressure at the contact point causes the accelerated dissolution of tungsten. Consequently flat surfaces are formed at the contact sites. As a result of dissolution and reprecipitation of tungsten, the shape of particles changes to a polygon. This phenomenon is called "flattening." An example of flattening of tungsten particles is shown in Figure 2. Thus, the data obtained by the experiment on Earth may not represent the exact growth behavior of the solid particles in a liquid matrix. If the experiments were done in a microgravity environment, the data corresponding to the theoretical growth behavior of solid particles could be achieved.

Experimental Procedure:

The mixtures of tungsten powder and nickel powder with the compositions of 3.5, 7, 15, 20, and 30 mass % Ni are prepared and compacted into cylindrical specimens. As illustrated in Figure 3, each specimen is inserted in an alumina (Al_2O_3) receptacle and five receptacles are put in a boron nitride (BN) container. The container is enclosed in a tantalum (Ta) capsule. The capsule is evacuated and filled with argon gas. Last, the capsule is put in a tantalum cartridge.

Two cartridges will be prepared and heated at 1550 °C in space (one for 1 h and the other for 3 h) in the FMPT experiment. The furnace and cartridge for the experiment is shown in Figure 4. The profiles of PS operation, sample temperature, heater power, and gas supply are shown in Figure 5.

The specimens will be cut and polished for metallographic measurement after return to Earth. Then the distribution curves of solid particle size will be determined and analyzed.

Tungsten	3410 °C	19.3 g/cm ³
Nickel	1453 °C	8.9 g/cm ³

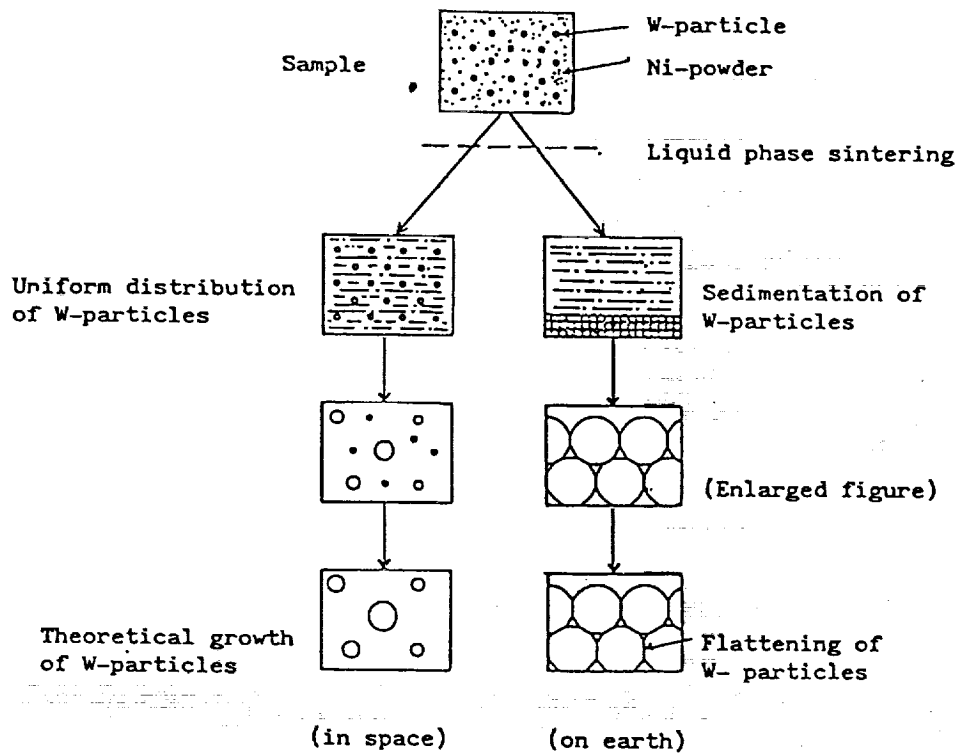

Figure 1. Illustration of the experiment.

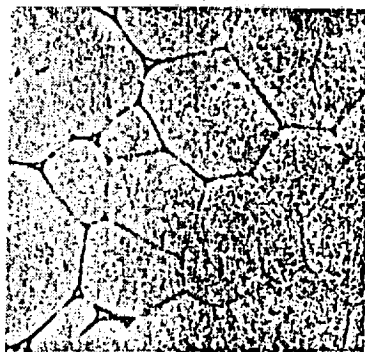

Figure 2. Flattening of tungsten particles.

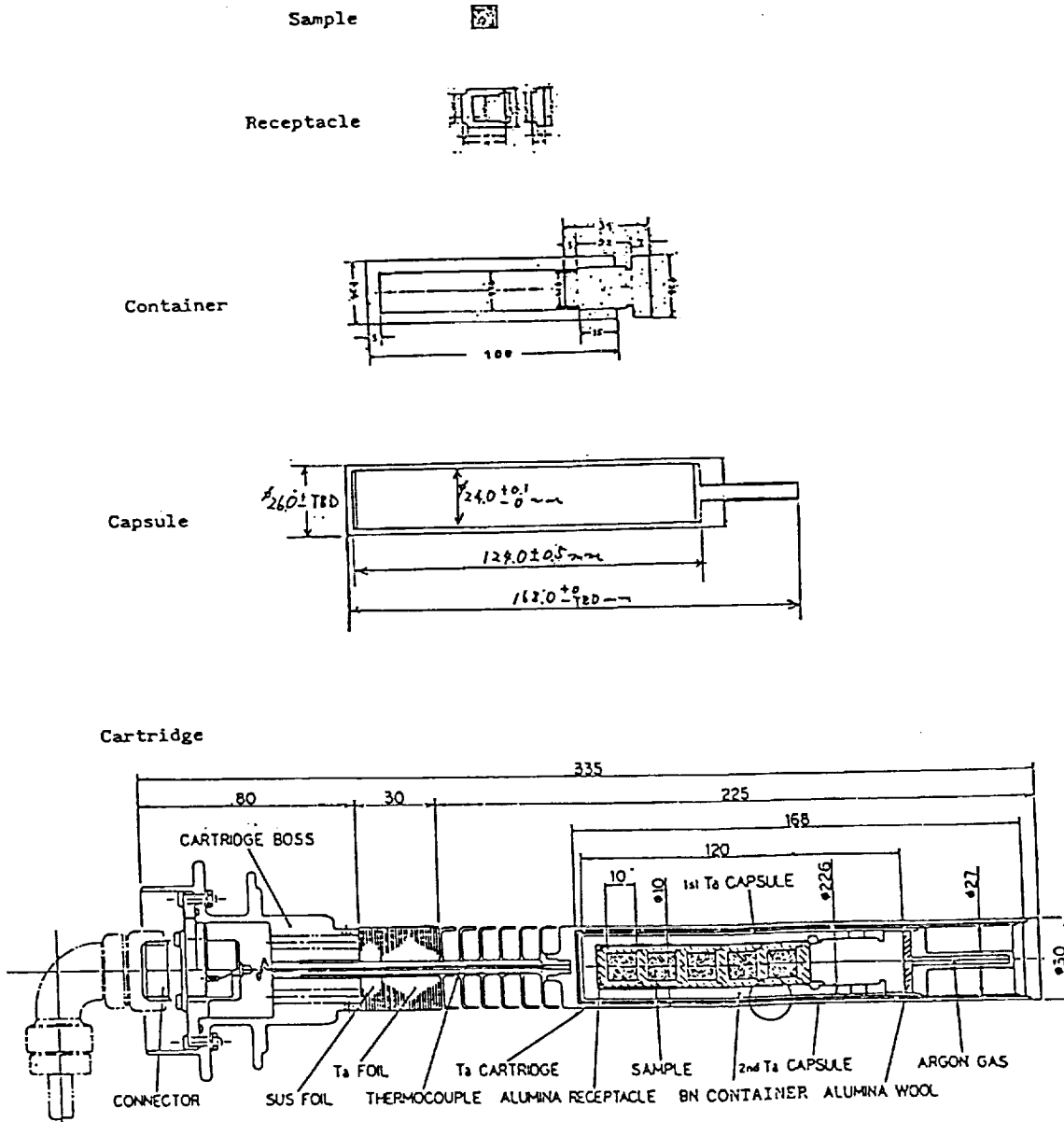

Figure 3. Setting of samples in a cartridge.

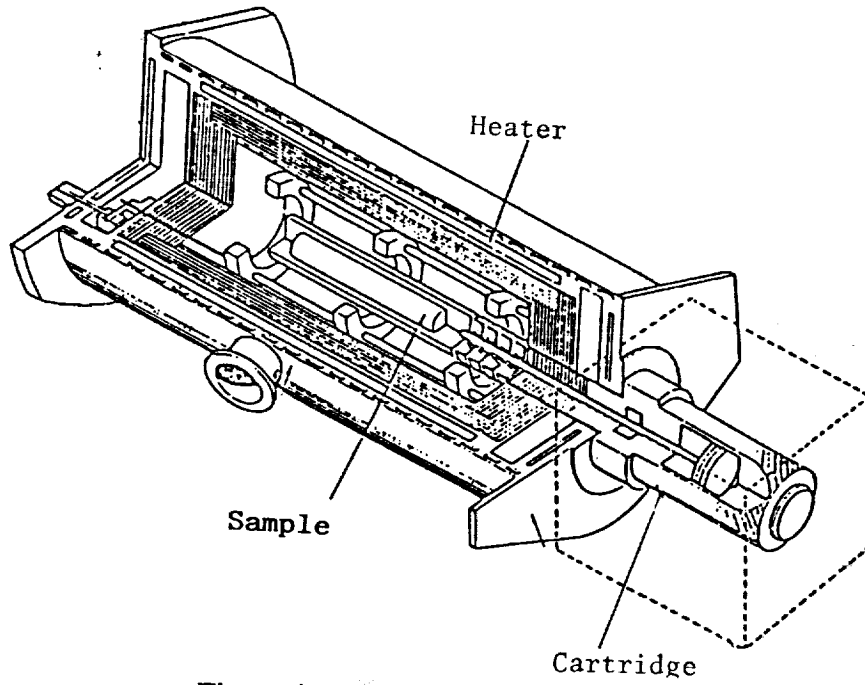

Figure 4. Heating furnace and cartridge.

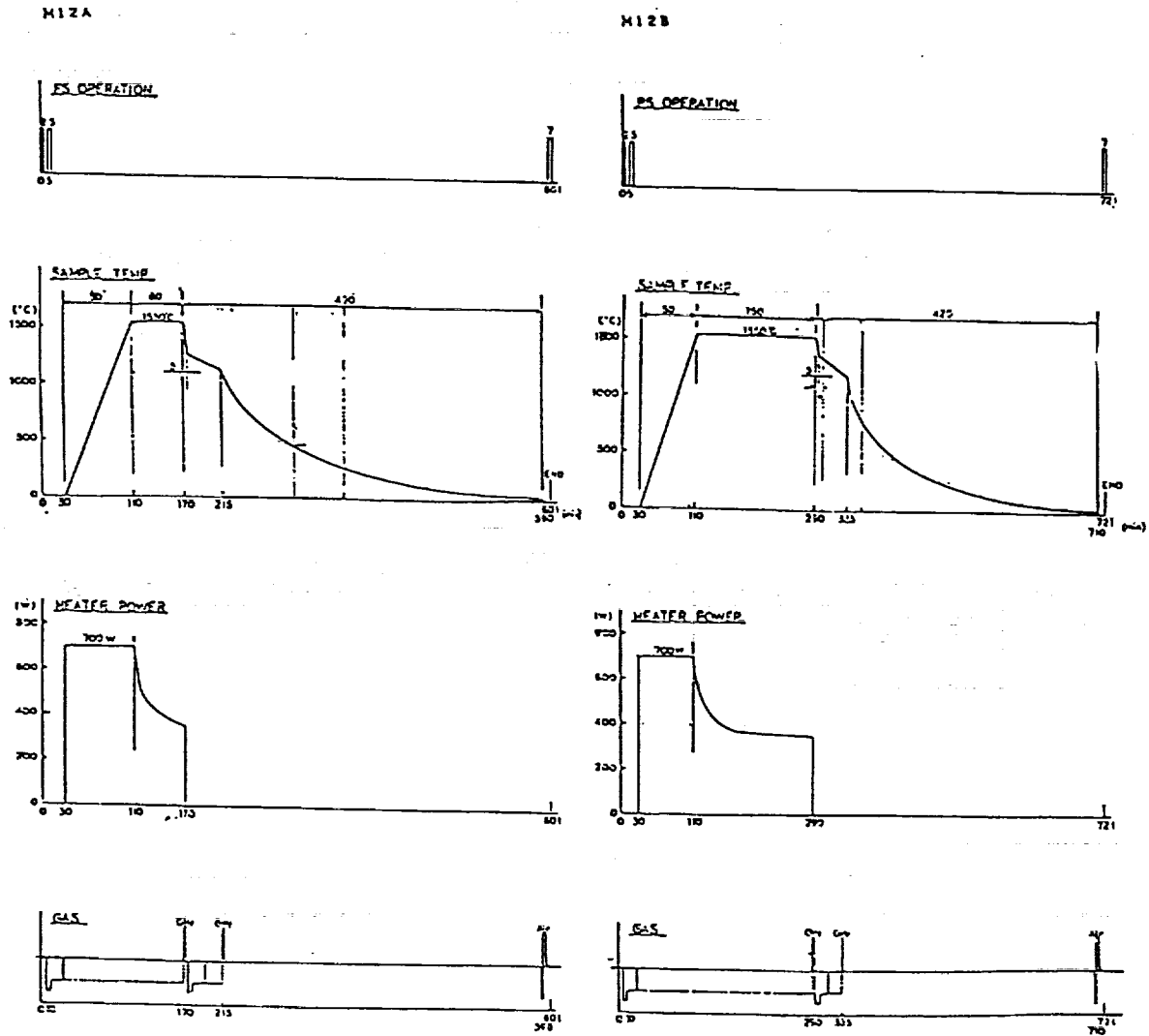

Figure 5. Experiment resource utilization profiles.