

N94-13746

**GAS-EVAPORATION IN LOW-GRAVITY FIELD
(COGELATION MECHANISM OF METAL VAPORS)
M-14**

**N. Wada
Nagoya University, Faculty of Science
Nagoya, Japan**

When metal and alloy compounds are heated and vaporized in a rare gas such as helium, argon, or xenon, the vaporized substances diffused in the rare gas are supersaturated resulting in a smoke of fine particles of the material congealing as snow or fog. The gas vaporizing method is a fine particle generation method. Though the method has a variety of applications, the material vapor flow is disturbed by gravitational convection on Earth. The inability to elucidate the fine particle generation mechanism results in an obstruction to improving the method to mass production levels.

As no convection occurs in microgravity in space, the fine particle generation mechanism influenced only by diffusion can be investigated. Investigators expect that excellent particles with homogeneous diameter distribution can be obtained. Experiment data and facts will assist in improving efficiency, quality, and scale or production processes including element processes such as vaporization, diffusion, and condensation.

Experiment Objectives

The objective of this experiment is to obtain important information related to the mechanism of particle formation in the gas atmosphere (smoke particles) and the production of sub-micron powders of extremely uniform size.

Experimental Procedures

Several glass chambers (Evaporation Bulbs) with evaporation sources (as on the filament) at the centers are prepared and filled with He or Xe gas of various pressure.

Heated by the filament, the metal is evaporated and the motion of the smoke produced is recorded by the VTR. The variations of the heating temperature, pressure, etc. are recorded simultaneously.

After the experiment each bulb will be brought back to the ground and the deposited particles observed using an electron microscope.

Expected Results

In the gravity field, the particle generation mechanism becomes complicated and results in various configurations and sizes of the particles because the vaporizing process is disturbed by convection. In the low-gravity field, the situation is much more simplified, provided that the vaporation is carried out at the center of spherical chamber. The diffusion of vapors into the gas atmosphere and the condensation into fine particles takes place in a spherical symmetric way.

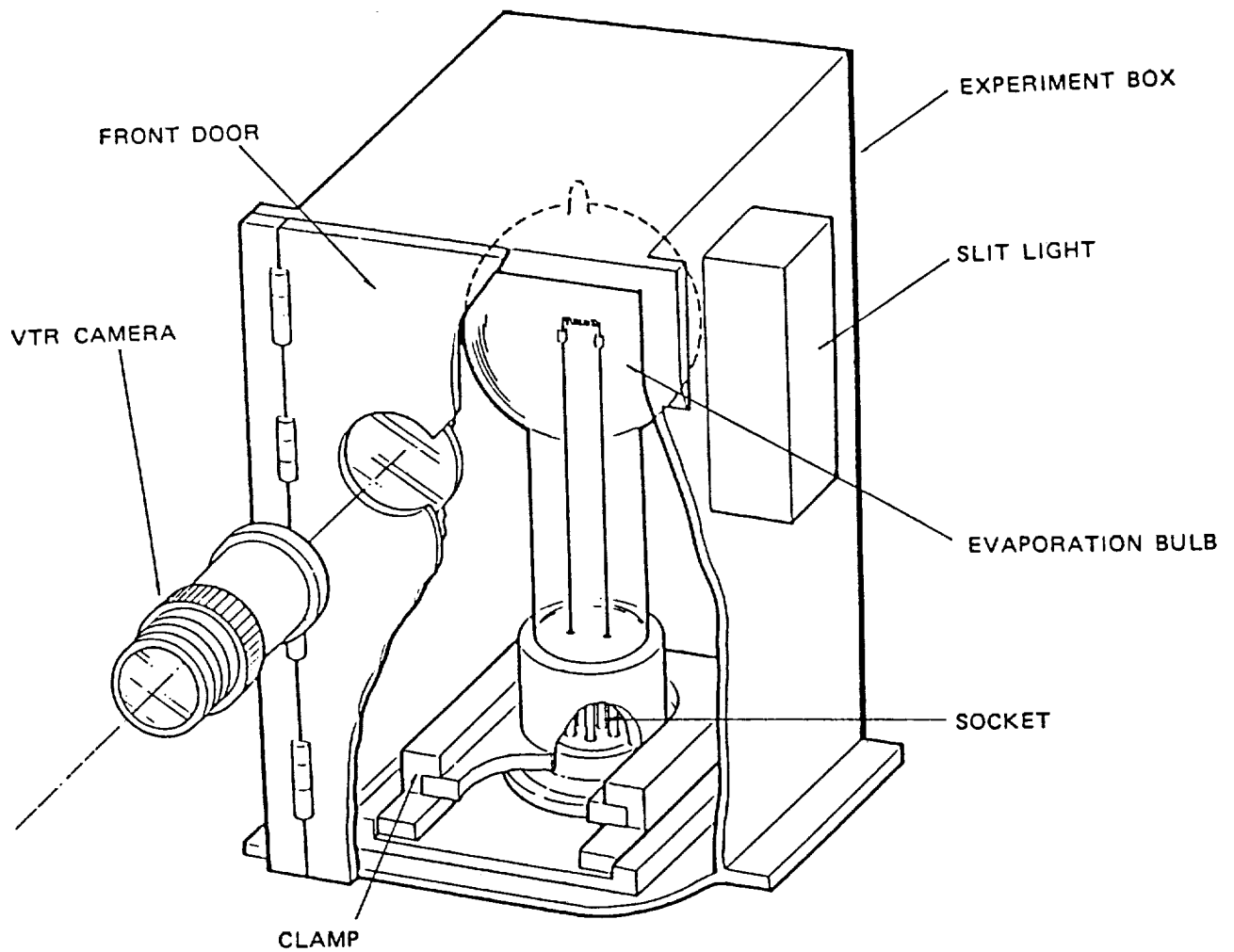

EVAPORATION BULB

- 1) Protection Cover (poly-carbonate)
- 2) Evaporation Bulb (glass 80 ϕ , sealed He or Xe)
- 3) Filament (W, Ta) with Metal sample (Ag or Al)
- 4) Thermo-couple (WRe-W)
- 5) Thermo-couple (PtRh-Pt)
- 6) Pressure Detector (quartz)
- 7) Stem (W-rod 2 ϕ)
- 8) Getter
- 9) Thermal reflector (quartz disk)
- 10) Electrode-Base (poly-carbonate)

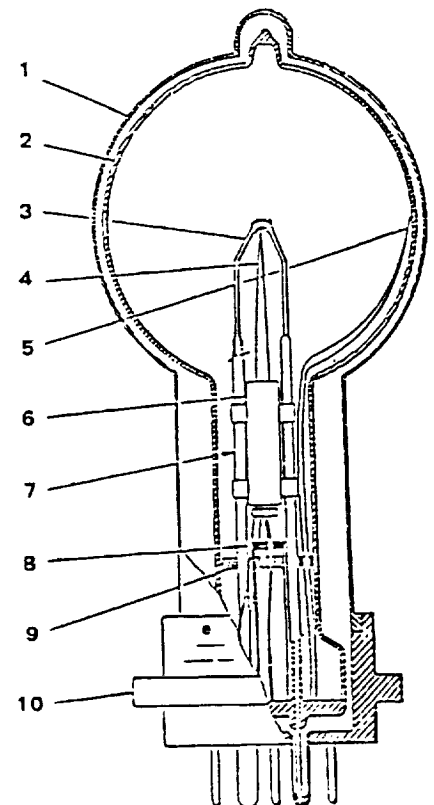

Figure 1. Gas Evaporation Experiment Facility.

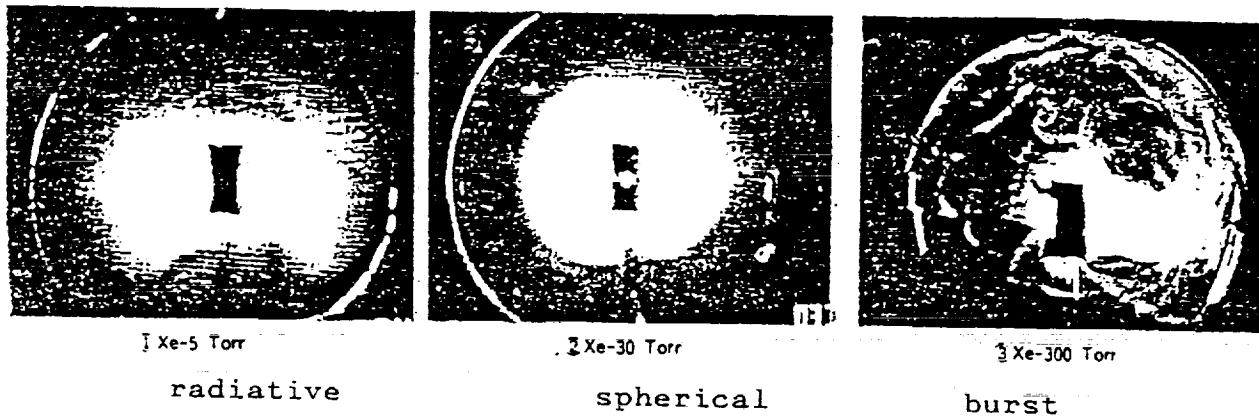

Figure 2. Deference of smoke shapes for the pressure difference of E.B (by airplane).