

N94-13752

## GROWTH OF SAMARSKITE CRYSTAL UNDER MICROGRAVITY CONDITIONS M-20

S. Takekawa  
National Institute for Research in Inorganic Materials  
Japan

### Purpose of the Experiment

To grow single crystals of samarskite under microgravity conditions by the traveling solvent float zone (TSFZ) method.

To study the phase relations in the samarskite-related systems involving liquid phases by the slow cooling float zone (SCFZ) method.

Samarskite is one of the minerals in a metamict state and is composed of Ca,Fe,Y,U, Th,Nb,Ta,O, etc.  $\alpha$ -particles radiating from uranium and/or thorium in the samarskite itself has destroyed its original structure without damaging its chemical composition and its external form. Consequently its structure has been converted into a vitreous structure.

### The TSFZ Method

The TSFZ method is for growing a single crystal (B) of an incongruently melting compound from the high temperature solution having the composition (S) which coexists with the solid phase (B). B denotes the composition of the compound B in Figure 1. S denotes the composition of the high temperature solution coexisting with the compound B in Figure 1.

## The SCFZ Method

The SCFZ method is for investigating the phase relations in the system involving liquid phases. The samples are melted and solidified in the controlled solidification process by using a float zone apparatus. The whole solidification sequence of the solidified phases and the concentration distribution in the solidified bodies are disclosed by means of EPMA technique. The phase relations are revealed by using the information obtained with the procedure described above. The scheme for explaining the method is shown in Figure 2.

The chemical formula of our sample is expressed by  $\text{Ca}_{0.24}\text{U}_{0.20}\text{Y}_{0.84}\text{Fe}_{1.56}\text{Nb}_{5.04}\text{O}_{16}$  and the shape is shown in Figure 3. The weight of uranium in the sample is 0.0669 g and its radioactivity is 0.0223  $\mu\text{Ci}$ .

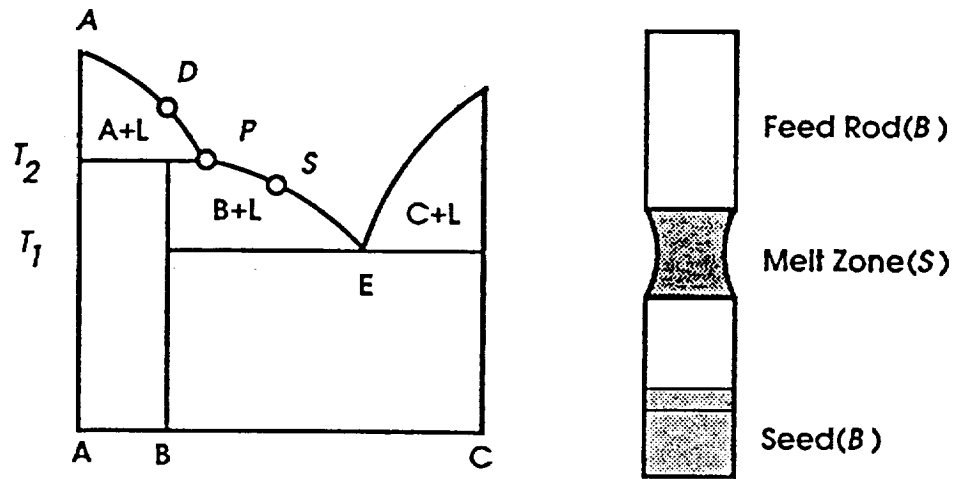

Figure 1. TSFZ method.

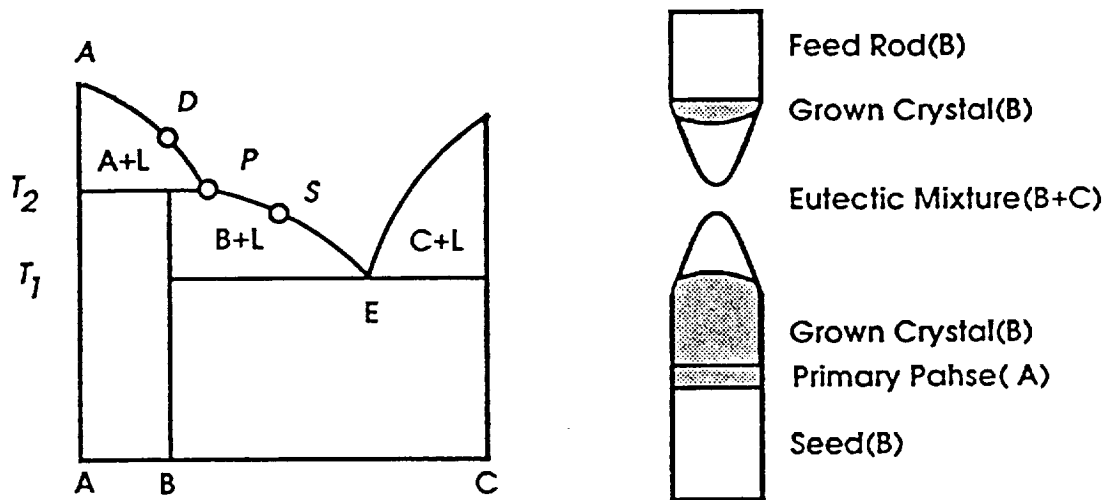

Figure 2. SCFZ method.

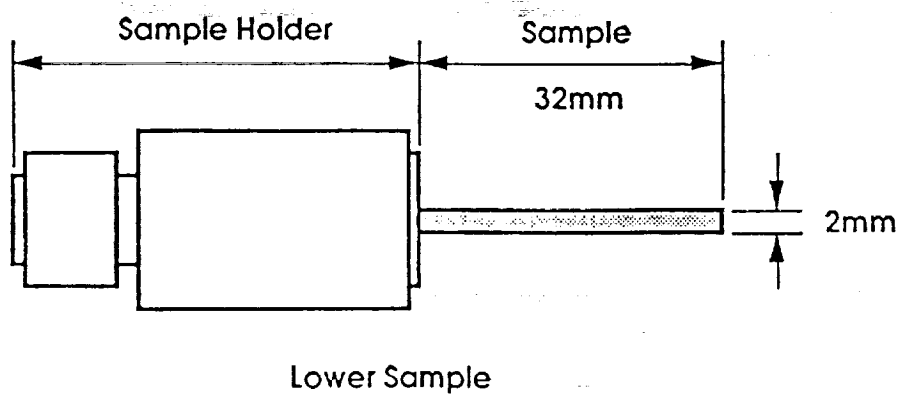
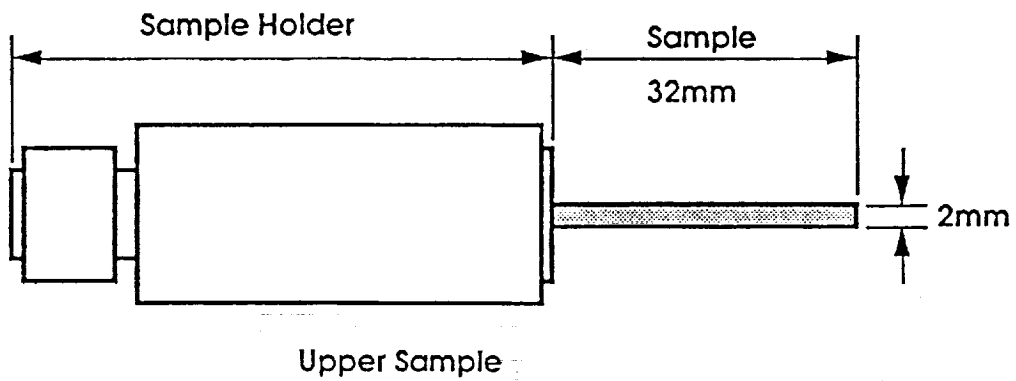

Figure 3. Samples.

### Stages in the Experiment

The experiment is consists of 7 stages(shown in Fig.4). The function in each stage is shown in below.

- ① Prepare the experimental environment such as setting up samples, quartz tube, IMF.
- ② Lamp power is automatically increased up to 260W. No PS task.
- ③ Build melt zone. If necessary, increase or decrease lamp power.
- ④ Single crystal growth by the TSFZ method. If necessary, adjust the shape of melt zone.
- ⑤ Study of phase relations by SCFZ method. No PS task.
- ⑥ Upper shaft moves upward rapidly to cut off the melt zone with certainty and Lamp power is automatically decreased down to 0W. No PS task.
- ⑦ Restore samples, quartz tube etc. and make IMF into the initial condition.

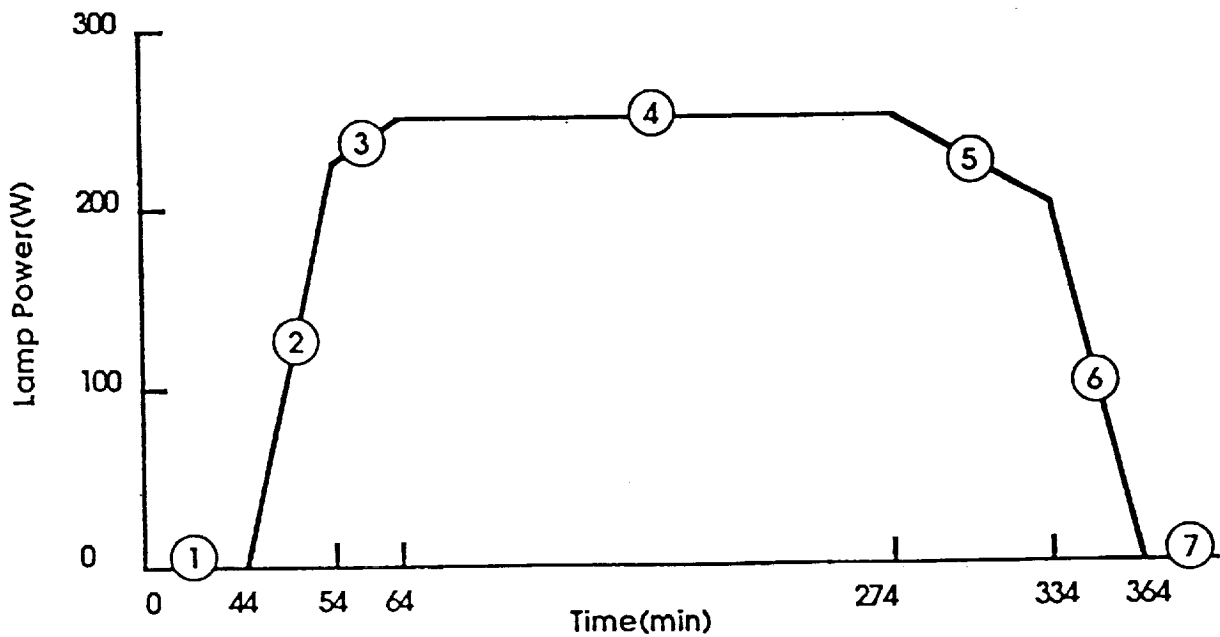

Figure 4. Experiment stages.

