

TWO WAVELENGTH SATELLITE LASER RANGING USING SPAD

N 9 4 - 1 5 5 8 4

I.Prochazka, K.Hamal, H.Jelinkova

Faculty of Nuclear Science and Physical Engineering, Czech Technical University
Brehova 7, 115 19 Prague 1, Czechoslovakia
phone/fax +42 2 848840, tlx 121254, bitnet TJEAN@CSEARN.BITNET

G.Kirchner, F.Koidl

Lustbuehel Observatory, Lustbuehel str. 46, A-8042 Graz, Austria
phone +43 316 472231, fax +43 316 462678

GENERAL

When ranging to satellites with lasers, there are several principal contributions to the error budget : from the laser ranging system on the ground, from the satellite retro array geometry and from the atmosphere. Using a single wavelength we have been routinely achieved a ranging precision of 8 millimeters when ranging to the ERS-1 and Starlette satellites. The systematic error of the atmosphere, assuming the existing dispersion models, is expected to be of the order of 1 cm. Multiple wavelengths ranging might contribute to the refinement of the existing models. Taking into account the energy balance, the existing picosecond lasers and the existing receiver and detection technology, several pairs or multiple wavelengths may be considered. To be able to improve the atmospheric models to the subcentimeter accuracy level, the Differential Time Interval (DTI) has to be determined within a few picoseconds depending on the selected wavelength pair [1].

There exist several projects, based on picosecond lasers as transmitters and on two types of detection techniques : one is based on a photo detectors like photomultipliers or photodiodes connected to the time interval meters [5]. Another technique is based on the use of a streak camera as a echo signal detector, temporal analyzer and time interval vernier. The temporal analysis at a single wavelength using the streak camera showed the complexity of the problem [2].

EXPERIMENT SETUP

We are reporting on the novel concept of ranging to satellites at two wavelengths using a single solid state photon counter. The block scheme is plotted on Figure 1. The receiver package is based on the Silicon avalanche photodiode [4] capable of single photon detection. The receiver and detector is common for both wavelengths, the different color returns are separated in time due to the atmospheric dispersion. In principle, the use of common detector for both wavelengths results in system simplicity, stability and accuracy, as well. Most of the DTI measurement error contributions cancel out by averaging. The system calibration is simple and straightforward.

The experiment has been accomplished at the Satellite Laser Ranging Station Graz, Austria, employing the 0.5 meter aperture Contraves tracking telescope. Considering the available laser technology, the satellite laser telescope transmitter and receiver optics, namely

the Coude path dielectric coatings, and the detector sensitivity, we have chosen the wavelength pair of $0.532 \mu\text{m}$ and $0.683 \mu\text{m}$ proposed by J.Gaignebet [3]. The laser transmitter consists of the passively mode locked Quantel Nd:AG laser including the second harmonic generator, modified by inserting a Raman cell filled by Hydrogen at 25 Bars, delivering $15 \text{ mJ}/35 \text{ psec}$ at $0.532 \mu\text{m}$ and $5 \text{ mJ}/25 \text{ psec}$ at the $0.683 \mu\text{m}$ Stokes waves. Additionally, the anti Stokes radiation at $0.45 \mu\text{m}$ having the energy of $1\text{-}3 \text{ mJ}$ is generated.

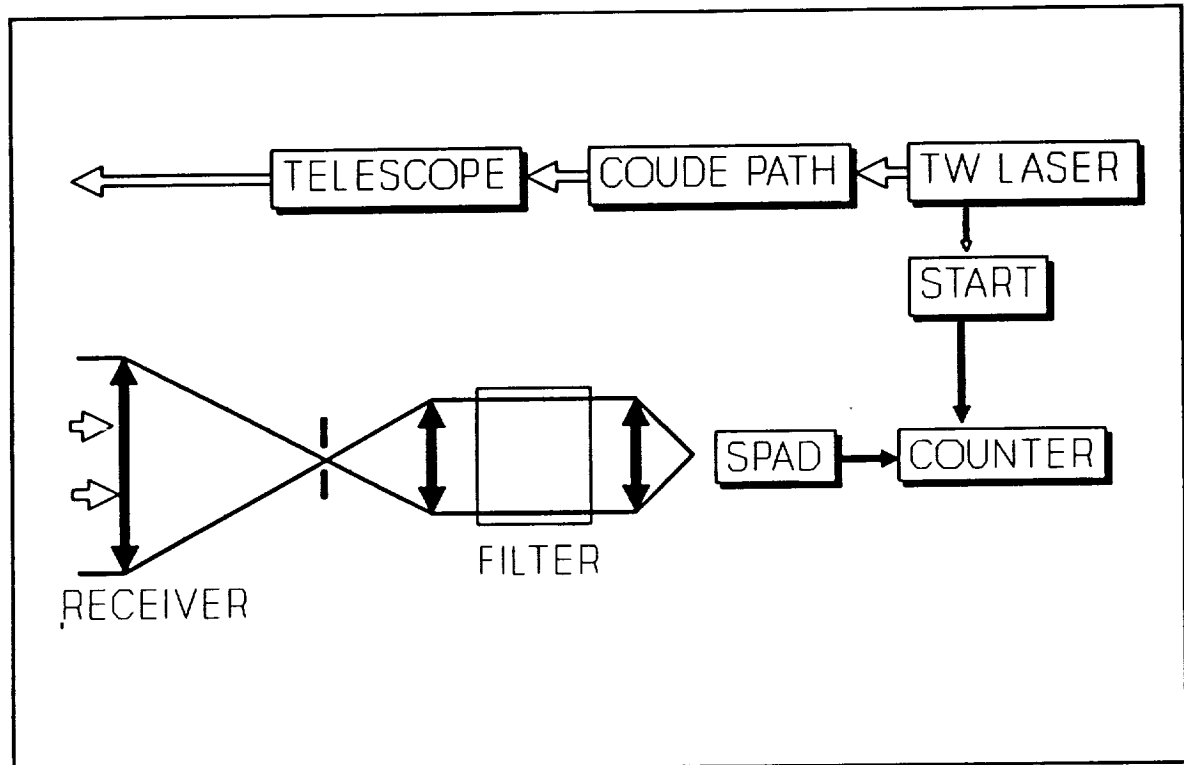

Figure 1 Two wavelengths laser ranging system setup using SPAD

RESULTS

Ranging to several ground targets we obtained a ranging precision of 42 picoseconds at $0.532 \mu\text{m}$ and 56 picoseconds at $0.683 \mu\text{m}$. The detector quantum efficiency at both these wavelengths reaches 20 %. The 6 kilometer distant ground target ranging results is shown on Figure 2. The first peak corresponds to $0.683 \mu\text{m}$ echoes, the second one to the $0.532 \mu\text{m}$ echoes. The measured DTI was 303.3 picoseconds. Taking into account the data of the atmosphere at this time, the calculated value is 299.4 picoseconds. The precision estimate of our DTI measurement is 4 picoseconds, if 400 returns per color are accumulated.

The first results of two wavelength laser ranging to the Ajisai satellite is on Figure 3, where the range residuals to the fitted orbit are plotted. The lower trace corresponds to the $0.683 \mu\text{m}$ echoes, the upper one to the $0.532 \mu\text{m}$ echoes. The DTI value variation along the pass is caused by changes in the satellite elevation and hence the atmospheric path difference. Up to now the satellites Lageos, ERS-1 and Ajisai have been ranged with two wavelengths. Typically a few hundreds of returns per pass and per wavelength have been collected when the system has been operating at 2.5 Hz. Averaging the two wavelengths data over the whole pass, the two wavelengths differential time interval has been determined with the precision typically 7 picoseconds.

2-COLOR RANGING TO TARGET

RESIDUALS of 532/683 nm Pulses

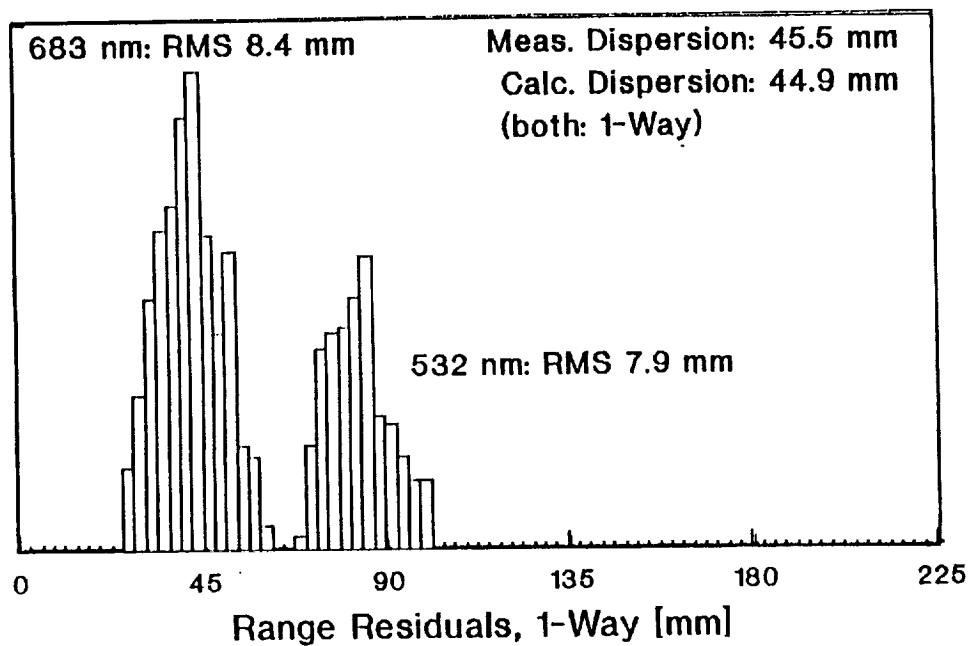

1991-12-12

Fig. 2

Satellite AJISAI

2-Color Ranging: 532 and 683 nm

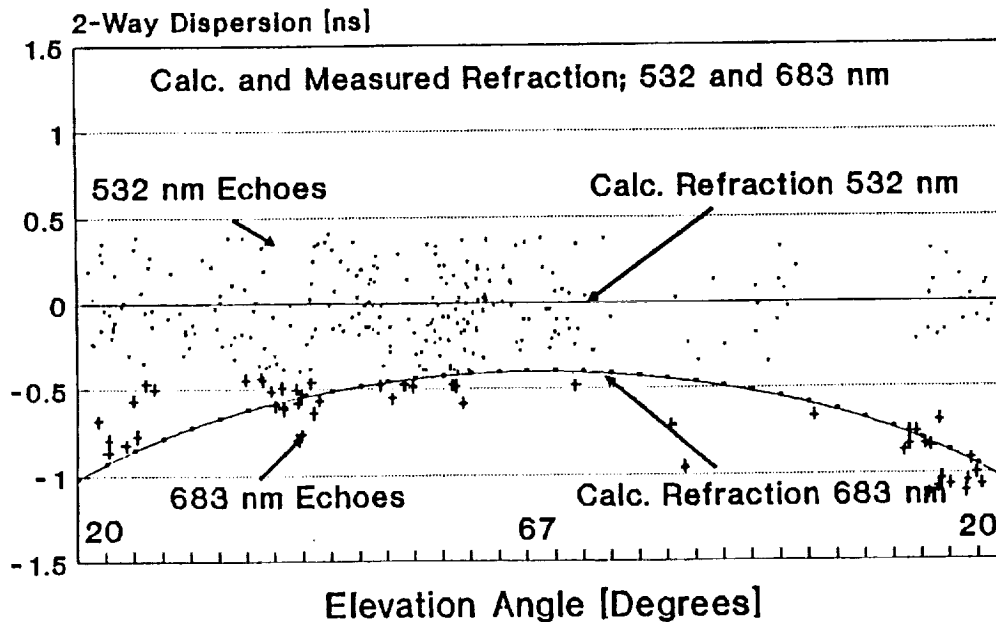

1991-12-12

Fig. 3

The energy budget, the number of returns per wavelength and hence the differential time interval precision has been limited by the system ranging repetition rate of 2.5 Hz, which is determined by the station ranging electronics. Additional limitation is the chromatic aberration of the transmitter refracting telescope, which limits the minimal divergence achievable simultaneously on both wavelengths. These two limitations are expected to be resolved within 1992.

CONCLUSION

Taking into account the energy budget when ranging to a satellite, assuming the data rate requested for two minute burst averaging and the ground target ranging results, one may conclude, that the picosecond accuracy of the two wavelength time difference interval is achievable using this technique. Comparing to the other two wavelengths ranging techniques, the simplicity, stability and the simple calibration is obvious. Some other wavelengths pairs, namely the Raman Stokes and anti Stokes, resulting in a considerably higher value of DTI may be considered. However, the telescope transmitter beam delivering optics has to be reconstructed.

References

1. J.B. Abshire, Applied Optics, Vol.19, No.20, 1980, p34-36
2. I.Prochazka, K.Hamal, G.Kirchner, M.Schelev, V.Lozaoui, V.Postovalov, SPIE 1449-40
3. J.Gaignebet et al, Technical Digest of the Conference on Lasers and Electro Optics, CLEO 89, Baltimore, MD, 1989
4. I.Prochazka et al, technical Digest of the Conference on Lasers and Electro Optics, CLEO 90, Anaheim, CA, May 1990
5. B.Greene, proc.of the 6th International Workshop on Laser Ranging Instrumentation, Antibes, France, 1986