

N94-15620

MULTI-BEAM LASER ALTIMETER

Jack L. Bufton
David J. Harding
Luis Ramos-Izquierdo

Laboratory for Terrestrial Physics
Goddard Space Flight Center
Greenbelt, MD

Laser altimetry provides a high-resolution, high-accuracy method for measurement of the elevation and horizontal variability of Earth-surface topography. The basis of the measurement is the timing of the round-trip propagation of short-duration pulses of laser radiation between a spacecraft and the Earth's surface. Vertical (i.e. surface elevation) resolution of the altimetry measurement is determined primarily by laser pulsewidth, surface-induced spreading in time of the reflected pulse, and the timing precision of the altimeter electronics. With conventional gain-switched pulses from solid-state lasers and sub-nsec resolution electronics, sub-meter vertical range resolution is possible from orbital altitudes of several hundred kilometers. Horizontal resolution is a function of laser beam footprint size at the surface and the spacing between successive laser pulses. Laser divergence angle and altimeter platform height above the surface determine the laser footprint size at the surface; while laser pulse repetition-rate, laser transmitter beam configuration, and altimeter platform velocity determine the spacing between successive laser pulses.

Multiple laser transmitters in a single altimeter instrument provide across-track as well as along-track coverage that can be used to construct a range image (i.e. topographic map) of the Earth's surface. Figure 1 is an illustration of the pushbroom laser altimeter instrument measurement concept that utilizes multiple laser beams. This multi-beam laser altimeter (MBLA) contains modular laser sources arranged in a linear, across-track array. Simultaneous or near simultaneous measurements of range to the surface are possible by independent triggering of the multiple laser pulse transmitters and reception by a single telescope that is staring at nadir and is equipped with a multi-element linear detector array in its focal plane. This arrangement permits alignment of each transmitter output into a separate, dedicated receiver channel. The illustrated configuration is a linear, contiguous across-track array of 30 beams which produces a strip-image range map of the Earth's surface. This MBLA configuration is one possible arrangement to accomplish high accuracy terrestrial topographic mapping near the nadir track in a NASA Earth Probe mission devoted to global topographic measurements. The configuration can be changed in accord with required science products and available resources. Possible modifications in the design include variation of footprint size and/or footprint spacing both along-track and cross-track to produce the desired coverage or sampling density within the sensor swath width.

The illumination pattern incident on the Earth's surface from any one transmitter element is a two-dimensional circular pattern of laser irradiance, with a Gaussian spatial distribution of illumination intensity, that is produced by a single

transverse (spatial) mode of the laser cavity. The transmitted laser pulsewidth is short (i.e. ~ 5 nsec full-width-at-half-maximum). The temporal distribution of laser irradiance in the pulse is approximately Gaussian and is the result of multiple longitudinal laser cavity modes produced by the gain-switched (Q-switched) laser cavity. In an ideal altimeter application (e.g. measurement of a smooth water surface) the backscattered laser pulse retains the shape of the incident pulse. However in the general case, the height distribution (i.e. roughness) and slope of the surface within the laser footprint produce spreading in time of the laser pulse reflected to the receiver. After interaction of the laser footprint with a rough or sloping surface, the backscattered pulsewidth may be expanded to several tens to several hundreds of nsec. The spread pulse degrades range measurement accuracy but analysis of the received pulse shape provides additional information on surface structure.

Figure 2 illustrates the pulse spreading effect and portrays the measurement approach in laser altimetry by providing the time varying amplitude of an altimeter detector that observes both the transmitted and backscattered laser pulse. Pulse spreading, by re-distributing the available pulse energy into a larger time interval, acts to reduce the peak-power signal-to-noise-ratio, thus increasing the probability of error for the range measurement. Pulse spreading also adds timing uncertainty by slowing the rise time of the return signal. Variability in pulse rise time in turn produces a time-walk effect when conventional threshold-crossing time-interval-unit devices are used for the range measurement. The application of GHz-bandwidth digitization or multi-stop time-interval measurement to the receiver pulse waveform provides pulse shape data. Digitization is indicated by the horizontal axis tick marks in Figure 2. The centroid T_s of the pulse shape data is used to make a timing correction that provides the measure of range-to-surface. The centroid is in effect the mean round-trip time-of-flight range to surface features within the laser footprint, weighted by: (1) the input two-dimensional Gaussian illumination pattern; (2) the reflectivity and areal extent of the surface features; and (3) the laser altimeter receiver transfer function.

The pulsewidth (or rms pulse spreading) that is derived from digitizer or multi-stop timing data is used to assess the magnitude of surface slope and/or surface structure within the footprint. Pulse spreading data taken together with along-track and across-track slope information provided by adjacent range pixels, enables calculation of the sub-pixel (footprint) slope or roughness. An analytical expression has been developed (Gardner, 1991) to express pulse spreading (mean square pulse width) in terms of the laser altimeter system parameters, beam curvature, nadir angle of observation, surface slope, surface roughness, and laser receiver operating signal-to-noise ratio.

The total area under the received pulse is proportional to pulse energy and is a measure of surface reflectance at the monochromatic $1 \mu\text{m}$ laser wavelength. Effective use of this reflectance data requires normalization by laser transmitter energy and consideration for atmospheric transmission. Reflectance data acquired with the pushbroom scan pattern of the laser altimeter provide an imaging capability that supplements the ranging functions. Since this image is acquired with an active sensor that transmits and receives only near nadir (180° phase function, i.e. backscatter mode), the surface illumination angle is fixed within 1° of zenith and the resultant image is free of bidirectional reflectance effects that exist in passive images with variable solar illumination geometries. Surface slope effects

on this reflectance image can also be directly characterized from the associated laser altimeter along-track and across-track range measurement record.

The functional block diagram of the multi-beam laser altimeter instrument appears in Figure 3. The laser transmitter module, receiver telescope, detector package, ranging and waveform electronics, GPS receiver, and pointing attitude measurement components form the major instrument subsystems. These subsystems are packaged into a common structure that provides a rigid platform for the laser transmitter, receiver optical components, and dual star cameras. The size of this structure is primarily dependent on telescope aperture (~ 0.9 m). The key component of the laser altimeter instrument structure is a lightweight, rigid optical bench illustrated in the perspective view of the MBLA Instrument in Figure 4 and the cross-sectional view of Figure 5. The altimeter telescope primary mirror is attached to the nadir-viewing side of the optical bench and the laser transmitter modules, detector package, and dual star cameras are attached to the opposite side. This construction ties all the transmitter and receiver optics together for maintenance of arc sec alignment. Beryllium is the material of choice for fabrication of the telescope optics and structure, optical bench, laser module cases, and the star camera mounting brackets. Beryllium provides a rigid optical platform, superior thermal diffusivity for removal of waste heat, an athermal optical train, and a minimum total mass. With these beryllium components, the design illustrated in Figure 5 has a mass of ~ 60 kg. Mass of the altimetry electronics, instrument computer, thermal, power, and GPS receiver subsystems bring the instrument total to ~ 100 kg.

The pulsed transmitter is based on high-power neodymium (Nd)-doped solid-state laser crystals and employs the Q-switching technique to concentrate laser energy in a short pulse. Each of the 30 laser transmitter modules illustrated in Figure 5 is optically-pumped by separate AlGaAs laser diode arrays that are coupled into the Nd laser crystal by fiber-optic cables. This results in an all-optical laser module that is separated from the electronic and power supply components of the laser subsystem. The majority of thermal dissipation for the laser modules can thus be grouped together and placed at a remote radiator location in the spacecraft instrument. The laser module design is a scaled version of present-day commercial diode-pumped Nd laser technology that is in use in NASA airborne laser altimeter systems. The illustrated array of laser transmitter modules is capable of producing ~ 7000 pulses-per-sec and requires average input electrical power of 1 kW when operational.

Optical backscatter from the Earth's surface is collected by the MBLA telescope that is fixed in orientation at the nadir track of the spacecraft. A series of two optical lenses and optical bandpass filters are used to collimate, filter, and then focus the backscattered radiation on the detector plane. Each laser transmitter element is angle-mapped into a silicon avalanche photodiode detector array element for a continuous two-dimensional range and reflectivity image of the surface. Energy measurements are made for the transmitted and received laser pulses and are affected by the reflectivity and transmission of the various optical surfaces in the instrument as well as detector sensitivity. Optical contamination and degradation for long term exposure to the space environment are potential problems. An on-board laser diode emitter can be utilized as a calibration source and coupled with fiber optics into the optical detectors. This method will maintain calibration for the energy measurement for surface reflectance studies.

Pointing attitude knowledge is generated by dual star cameras. Each camera is a second-generation star tracker that employs a 2-dimensional CCD array that is capable of simultaneous tracking of as many as five stars. On-board Kalman-filtering is utilized to compare stellar angular position data with a star catalog and provide an output pointing attitude estimate; in principle eliminating the need for an inertial reference unit. Both star cameras are capable of 1 arc sec (total angle) pointing knowledge limited by the quality of the star catalog. The dual star camera system can provide the 2 arc sec total angle (1-sigma) knowledge required for sub-meter accuracy altimetry. Pointing angle data are continuously generated with-respect-to the stellar inertial reference frame. Laser pointing angles are tied to the star camera data through beam angle sensors which sample a portion of one or more output laser pulses and measure the angle (at the arc-sec level) of reflection from reference mirrors on the star cameras. Output laser pulse samples are also coupled with retroreflectors directly into the receiver telescope in order to assess alignment shifts between telescope and lasers.

The pulse timing data, waveform digitizer, and pulse energy data form the basic laser altimeter dataset for each laser pulse. These data points accumulate in a buffer in digital form, are formatted into data blocks or files, and then enter the altimeter platform data stream for recording or telemetry. The expected data rate of the laser altimeter resulting from 1000 - 7000 laser pulse measurements a second is estimated to range from 10 - 50 kbps. On-board processing is planned for the ranging centroid correction and waveform shape data products. Data telemetry involves range-to-the-surface, waveform shape products, sensor housekeeping, pointing attitude, and GPS position data. Post processing on the ground is used to correct the altimetry data for the precision orbit and spacecraft pointing attitude. The basic data products are a gridded topographic map containing $\geq 10^{10}$ surface elevation measurements with the selected horizontal resolution (grid size) and an image of Earth's surface reflectance at 1 μm wavelength with a similar level of detail. These products will be developed with minimal ground processing, stored on compact optical disks, and made available to the scientific community in a timely fashion. Analysis and use of the topographic data will be done by the end user in the scientific community.

REFERENCE:

Gardner, C.S., "Generalized Target Signature Analysis for Laser Altimeters", Applied Optics, 1992.

ACKNOWLEDGMENTS:

The definition of the MBLA instrument was made possible through the efforts of a number of individuals in the Laboratory for Terrestrial Physics (LTP) at the Goddard Space Flight Center and in the aerospace industry. Notable among these efforts were those of David Rabine in the University Research Foundation of the Maryland Advanced Development Laboratory, Nita Walsh of Science Systems and Applications, Inc., Ying Hsu of the Optical Corporation of America, David Thompson of Spectrum Astro, Inc., and Tom Baer, Spectra Physics, Inc.

MULTI-BEAM LASER ALTIMETER MISSION CONCEPT

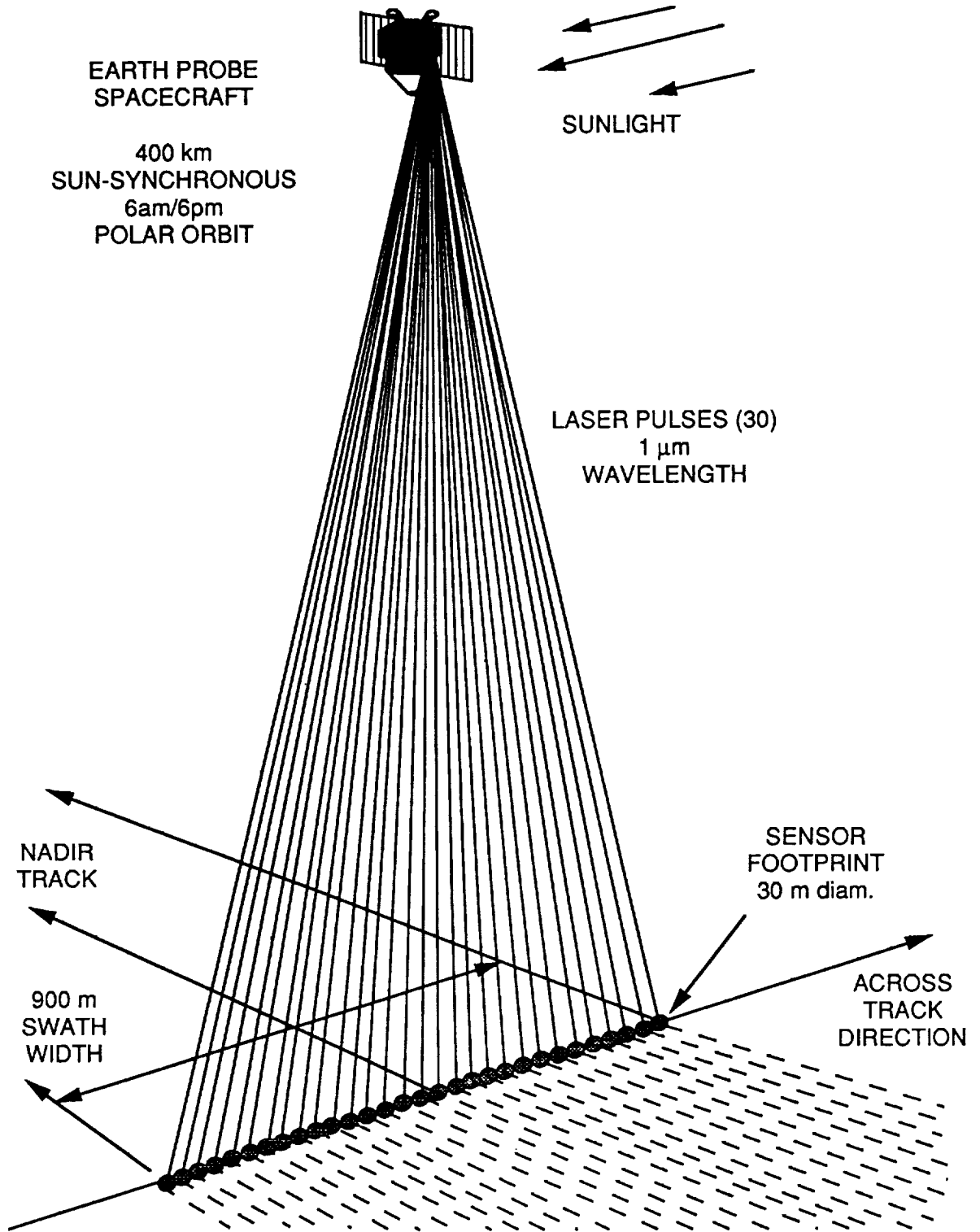
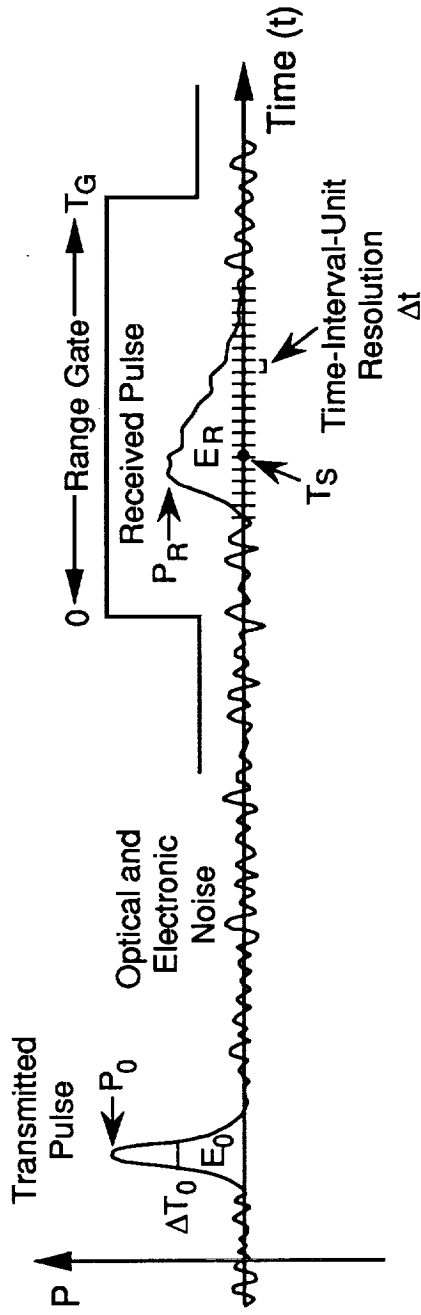

Fig. 1

LASER ALTIMETER PULSE WAVEFORMS



Pulse Centroid: $T_S = \int_0^{T_G} (1/T_G) \cdot t \cdot P(t) dt$

Fig. 2

MULTI-BEAM LASER ALTIMETER

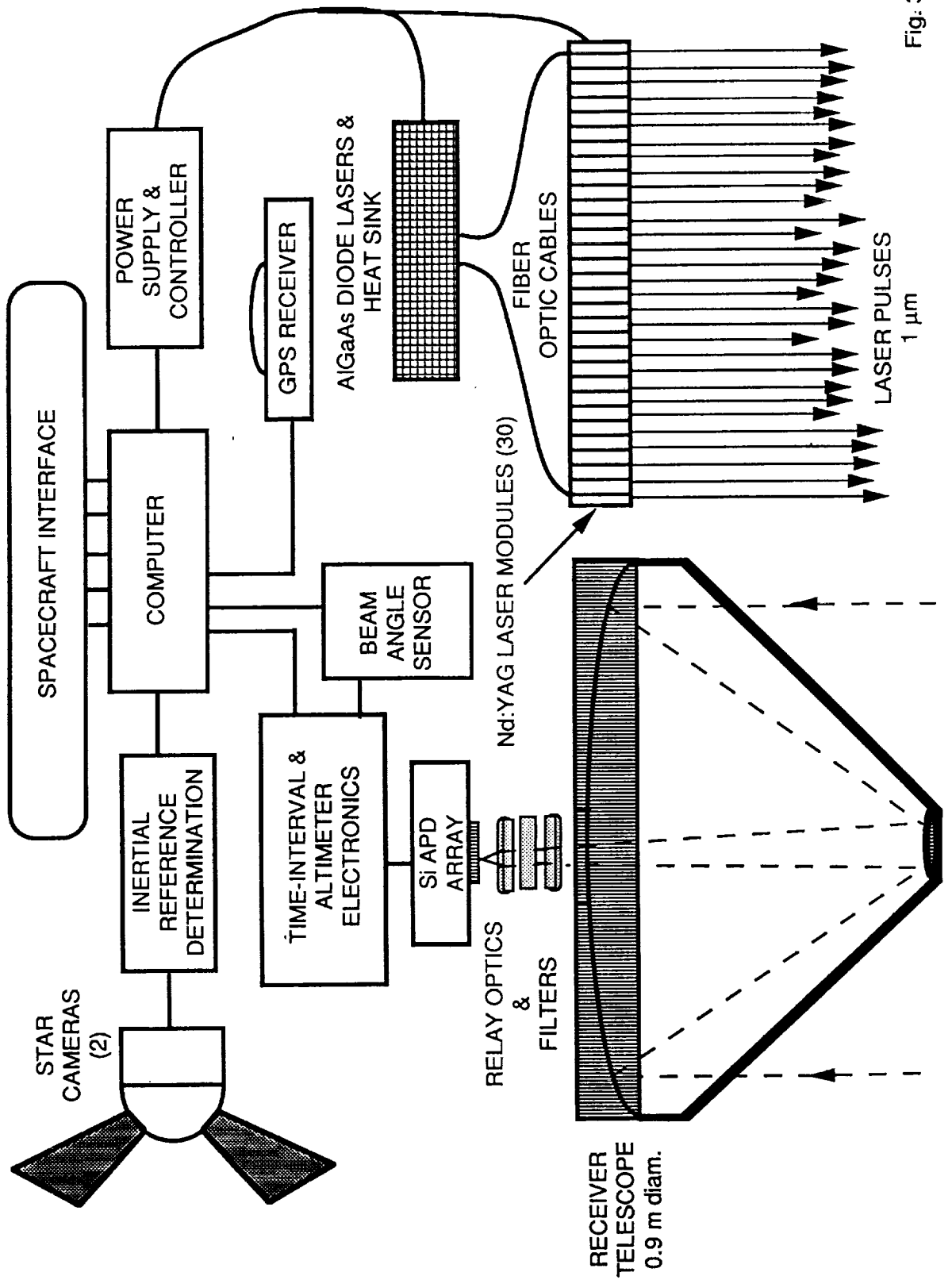
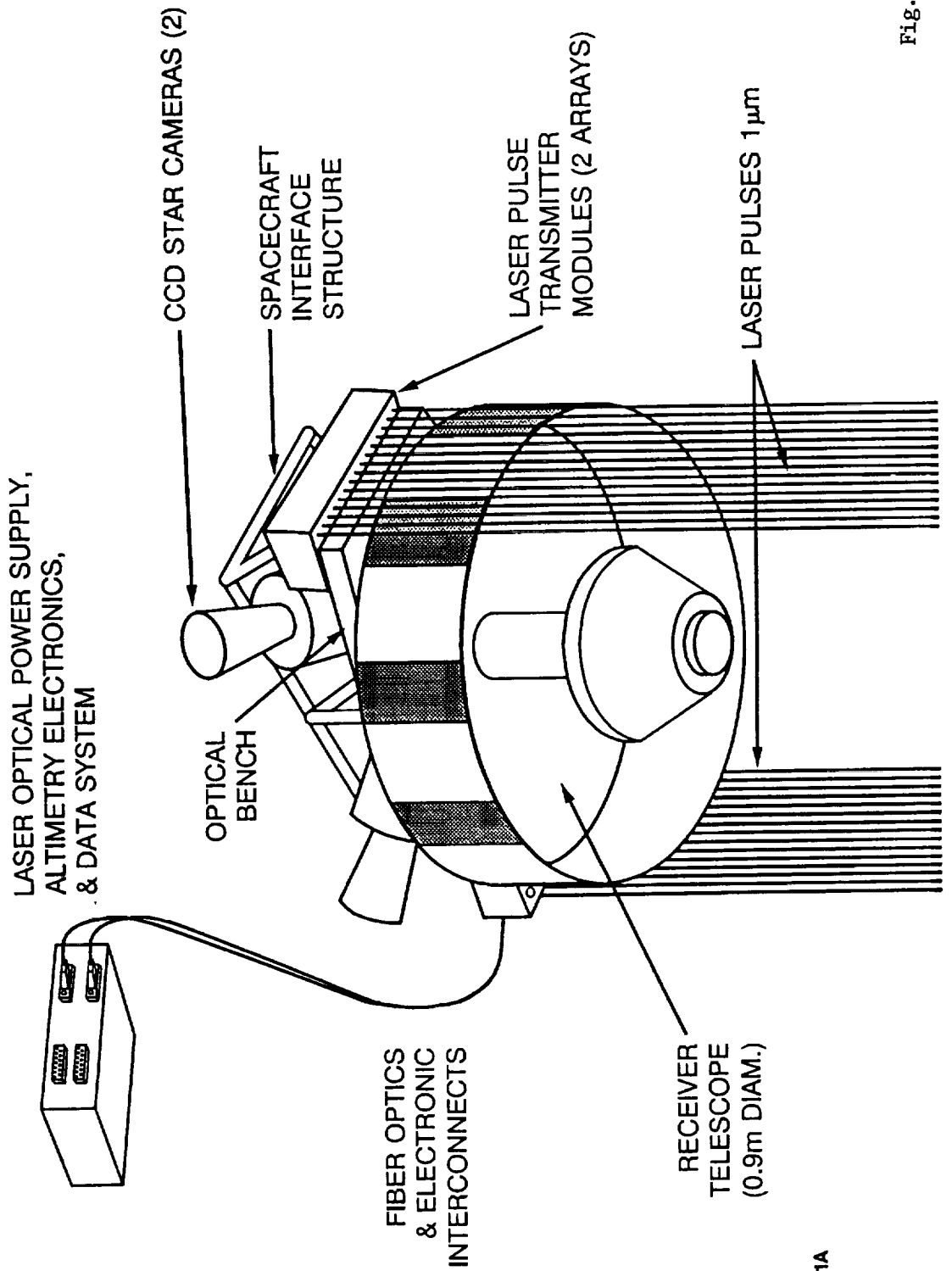

Fig: 3

MULTI-BEAM LASER ALTIMETER



H233.01A

MULTI-BEAM LASER ALTIMETER

elevation view

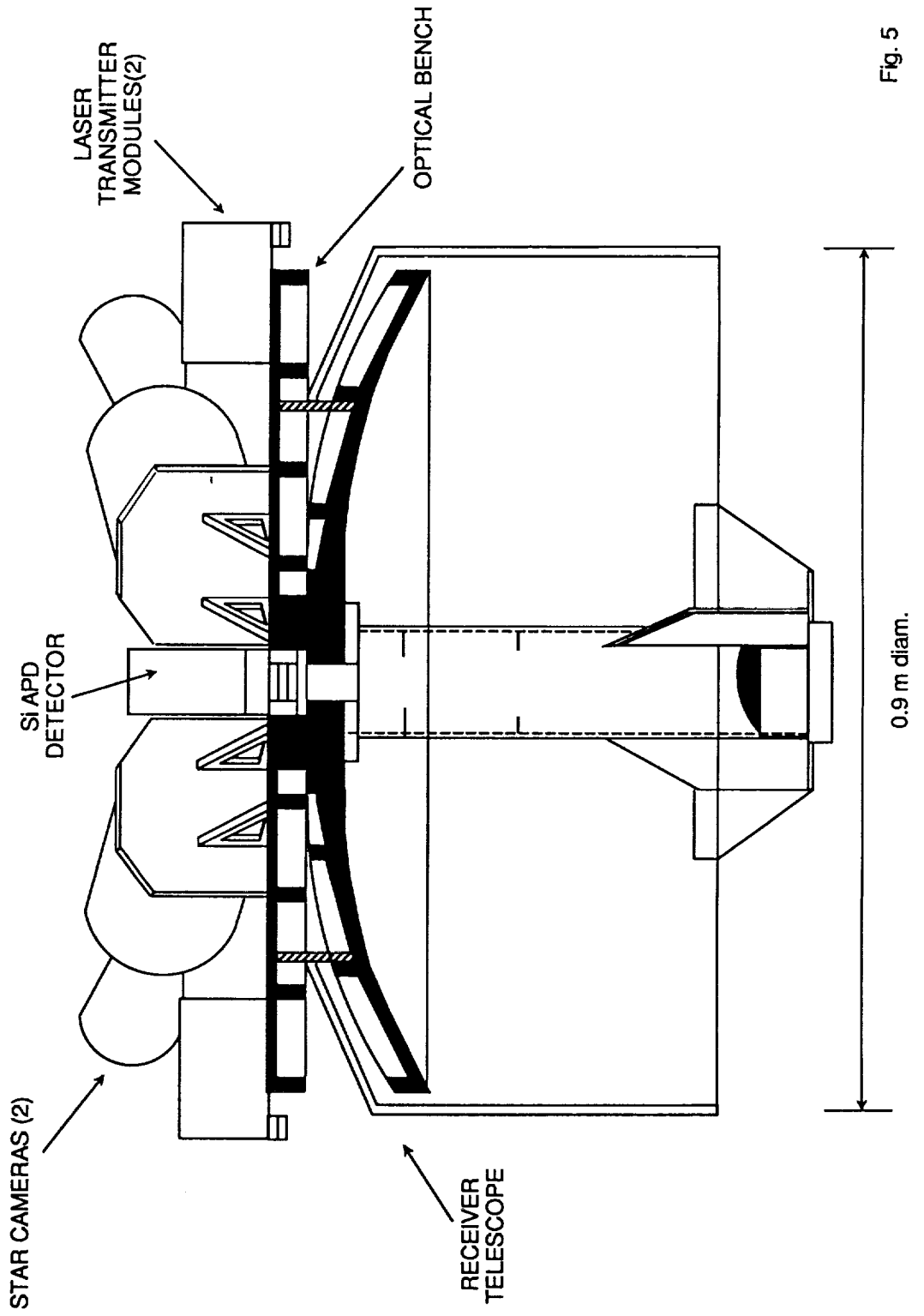

Fig. 5

Poster Presentations