

11-71  
193597  
257A

NASA Contractor Report 191484

# STRATEGIC PLANNING FOR AIRCRAFT NOISE ROUTE IMPACT ANALYSIS: A THREE DIMENSIONAL APPROACH

Prepared by:

C. R. Bragdon, M. J. Rowan and K. K. Ahuja  
*Georgia Tech Research Institute*  
*Georgia Institute of Technology*  
*Atlanta, Georgia 30332*

Prepared for  
Langley Research Center  
under Contract NAS1-19061  
(Task Assignment 9)  
September 1993

(NASA-CR-191484) STRATEGIC  
PLANNING FOR AIRCRAFT NOISE ROUTE  
IMPACT ANALYSIS: A THREE  
DIMENSIONAL APPROACH Final Report,  
12 Jul. 1991 - 15 Jan. 1993  
(Georgia Inst. of Tech.) 259 p

N94-17278

Unclass

G3/71 0193597



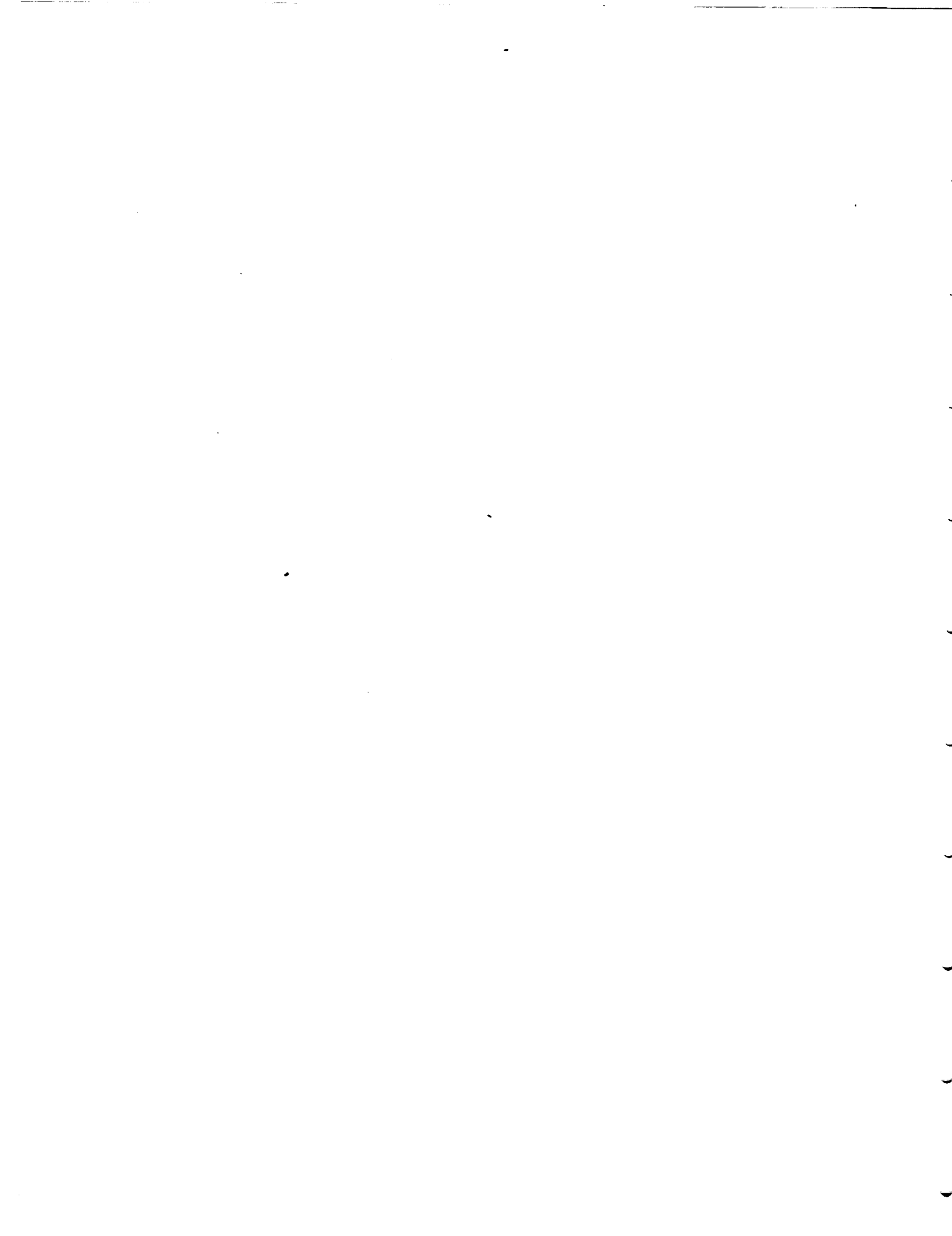

# TABLE OF CONTENTS

SUMMARY .....	vii
1.0 INTRODUCTION .....	1
1.1 Background .....	2
1.2 Objectives and Tasks .....	2
1.2.1 Geographic Information Systems .....	2
1.2.2 Sound Metrics and Descriptors and Noise Prediction Programs .....	3
1.2.3 Land Use Data bases .....	3
1.2.4 Governmental Regulatory Data bases .....	3
1.2.5 Airspace Operational Control Measures .....	3
1.2.6 Federal Regulations and Advisory Circulars Pertaining to Route Analysis .....	3
1.2.7 Census, Demographics, and Real Estate Based Analysis .....	3
1.2.8 Environmental Attributes .....	3
1.2.9 Feasibility of Developing a Comprehensive Three-Dimensional Route Impact Methodology .....	4
1.3 Methodology .....	4
1.4 Acknowledgements .....	4
2.0 GEOGRAPHIC INFORMATION SYSTEMS .....	7
2.1 Introduction .....	8
2.1.1 Purpose .....	8
2.1.2 Background .....	8
2.1.3 Interrelationship .....	12
2.1.4 Relevance .....	13
2.2 Methodology .....	16
2.2.1 General .....	16
2.2.2 Specific .....	17
2.3 Findings .....	21
2.4 Conclusion .....	21
2.4.1 Applicability .....	21
2.4.2 Comprehensiveness .....	21
2.4.3 Future .....	21
3.0 SOUND METRICS AND DESCRIPTORS .....	22
3.1 Introduction .....	23
3.1.1 Purpose .....	23
3.1.2 Background .....	23
3.1.3 Interrelationship .....	23
3.1.4 Relevance .....	24

	3.2 Methodology . . . . .	25
	3.2.1 General . . . . .	25
	3.2.2 Specific . . . . .	25
	3.3 Findings . . . . .	25
	3.3.1 Sound Descriptors and Metrics . . . . .	25
	3.3.2 Noise Prediction Programs . . . . .	26
	3.4 Conclusions . . . . .	29
4.0	LAND USE DATA BASES . . . . .	30
	4.1 Introduction . . . . .	31
	4.1.1 Purpose . . . . .	31
	4.1.2 Background . . . . .	31
	4.1.3 Interrelationship . . . . .	31
	4.1.4 Relevance . . . . .	32
	4.2 Methodology . . . . .	32
	4.2.1 General . . . . .	32
	4.2.2 Specific . . . . .	33
	4.3 Findings . . . . .	33
	4.3.1 Data bases at the National Level . . . . .	33
	4.3.2 Land Use Data bases at the State and Local Level . . . . .	35
	4.3.3 Land Use Data base from Individual GIS Vendors . . . . .	37
	4.3.4 Data Standardization and Coordination . . . . .	37
	4.4 Conclusion . . . . .	39
5.0	GOVERNMENTAL REGULATORY DATABASE . . . . .	40
	5.1 Introduction . . . . .	41
	5.1.1 Purpose . . . . .	41
	5.1.2 Background . . . . .	41
	5.1.3 Interrelationship . . . . .	42
	5.1.4 Relevance . . . . .	43
	5.2 Methodology . . . . .	43
	5.2.1 General . . . . .	43
	5.2.2 Specific . . . . .	43
	5.3 Findings . . . . .	43
	5.3.1 Noise Regulatory Provisions . . . . .	43
	5.3.2 Specific Noise Provisions . . . . .	46
	5.4 Conclusion . . . . .	61
	5.4.1 Applicability . . . . .	61
	5.4.2 Comprehensiveness . . . . .	61
	5.4.3 Future . . . . .	61
6.0	AIRSPACE OPERATIONAL CONTROL MEASURES . . . . .	62
	6.1 Introduction . . . . .	63
	6.1.1 Purpose . . . . .	63



	6.1.2 Background: Airspace .....	63
	6.1.3 Interrelationships .....	67
	6.1.4 Relevance .....	70
	6.2 Methodology .....	70
	6.3 Findings .....	72
	6.3.1 General Classifications .....	72
	6.3.2 Specific Description of Operational Control Measures .....	73
	6.4 Conclusion .....	77
	6.4.1 Applicability .....	77
	6.4.2 Comprehensiveness .....	78
	6.4.3 Future .....	78
7.0	<b>FEDERAL REGULATIONS AND ADVISORY CIRCULARS PERTAINING TO ROUTE ANALYSIS .....</b>	<b>84</b>
	7.1 Introduction .....	85
	7.1.1 Purpose .....	85
	7.1.2 Background .....	85
	7.1.3 Interrelationship .....	85
	7.1.4 Relevance .....	86
	7.2 Methodology .....	86
	7.2.1 General .....	86
	7.2.2 Specific .....	86
	7.3 Findings .....	87
	7.3.1 FAR PART 36 .....	87
	7.3.2 Advisory Circular Part 150: Noise Control and Compatibility Planning for Airports .....	88
	7.3.3 Part 77: Objects Affecting Navigable Airspace .....	93
	7.3.4 CFR Part 161 .....	95
	7.4 Conclusion .....	98
8.0	<b>CENSUS, DEMOGRAPHICS AND REAL ESTATE BASED DATA BASES .....</b>	<b>99</b>
	8.1 Introduction .....	100
	8.1.1 Purpose .....	100
	8.1.2 Background .....	100
	8.1.3 Interrelationship .....	100
	8.1.4 Relevance .....	101
	8.2 Methodology .....	101
	8.2.1 General .....	101
	8.2.2 Specific .....	102
	8.3 Findings .....	102
	8.3.1 Overview of Data from U.S. Bureau of the Census .....	102
	8.3.2 Use of the GIS in Real Estate .....	105

	8.3.3 Geographic Data . . . . .	109
8.4	Conclusion . . . . .	112
	8.4.1 Applicability . . . . .	112
	8.4.2 Comprehensiveness . . . . .	112
	8.4.3 Future . . . . .	113
9.0	<b>ENVIRONMENTAL ATTRIBUTES . . . . .</b>	<b>114</b>
9.1	Introduction . . . . .	115
	9.1.1 Purpose . . . . .	115
	9.1.2 Background . . . . .	115
	9.1.3 Interrelationship . . . . .	115
	9.1.4 Relevance . . . . .	116
9.2	Methodology . . . . .	118
	9.2.1 General . . . . .	118
	9.2.2 Specific . . . . .	120
9.3	Findings . . . . .	120
	9.3.1 Federal Flight Restrictions . . . . .	122
	9.3.2 Air Quality . . . . .	122
	9.3.3 Water Quality . . . . .	123
	9.3.4 Recreation Land . . . . .	124
	9.3.5 Historic, Architectural, Archeological Culture Resources . . . . .	124
	9.3.6 Endangered and Threatened Species of Flora and Fauna . . . . .	125
	9.3.7 Wetlands . . . . .	128
	9.3.8 Floodplains . . . . .	129
	9.3.9 Coastal Barriers . . . . .	130
	9.3.10 Wild and Scenic Rivers . . . . .	130
9.4	Conclusion . . . . .	131
	9.4.1 Applicability . . . . .	131
	9.4.2 Comprehensiveness . . . . .	132
10.0	<b>FEASIBILITY OF DEVELOPING A COMPREHENSIVE THREE-DIMENSIONAL ROUTE IMPACT METHODOLOGY . . . . .</b>	<b>133</b>
10.1	Introduction . . . . .	134
	10.1.1 Purpose . . . . .	134
	10.1.2 General . . . . .	134
10.2	Database Summary . . . . .	136
	10.2.1 Data Cost . . . . .	136
	10.2.2 Data Availability Trends . . . . .	141
	10.2.3 Standards . . . . .	142
	10.2.4 Summary . . . . .	144
10.3	GIS Status . . . . .	145
	10.3.1 Three-Dimensional Aspects . . . . .	146

10.4 Trends and Future Capabilities . . . . .	146
APPENDIX A: GLOSSARY OF GIS TERMS . . . . .	149
APPENDIX B: GIS SOFTWARE EVALUATION MATRIX . . . . .	152
APPENDIX C: INTEGRATED NOISE MODEL (INM) VERSION 3.10 . . . . .	156
APPENDIX D: ELEVATION USE DATA BASES . . . . .	159
APPENDIX E: LAND USE DATA BASES . . . . .	162
APPENDIX F: SOIL DATA BASES . . . . .	170
APPENDIX G: ANCILLARY DATA BASES OF SPECIALIZED INFORMATION . . . . .	172
APPENDIX H: SURVEY AND RESPONSES REGARDING MUNICIPAL NOISE REGULATIONS . . . . .	178
APPENDIX I: AIRSPACE DEFINITIONS . . . . .	187
APPENDIX J: FIELD HEADINGS FOR OPERATIONAL CONTROL MEASURES . . . . .	191
APPENDIX K: FAA PART 36: NOISE STANDARDS . . . . .	193
APPENDIX L: FAA PART 150: LAND USE COMPATIBILITY . . . . .	199
APPENDIX M: FAA PART 77: OBJECTS AFFECTING NAVIGABLE AIRSPACE . . . . .	202
APPENDIX N: HIERARCHY OF CENSUS GEOGRAPHY AND MAJOR CONTENTS OF 1990 CENSUS . . . . .	213
APPENDIX O: 1990 CENSUS OF POPULATION AND HOUSING REPORTS . . . . .	217
APPENDIX P: AIR QUALITY DATA BASES . . . . .	221
APPENDIX Q: WATER QUALITY DATA BASES . . . . .	223
APPENDIX R: PUBLIC LANDS DATA BASES . . . . .	226

APPENDIX S:	HISTORICAL SITES DATA BASES . . . . .	229
APPENDIX T:	ENDANGERED SPECIES DATA BASES . . . . .	231
APPENDIX U:	WETLANDS DATA BASES . . . . .	234
APPENDIX V:	FLOOD PRONE AREAS DATA BASES . . . . .	236
APPENDIX W:	COASTAL BARRIER DATA BASES . . . . .	238
APPENDIX X:	RECREATIONAL RIVER DATA BASES . . . . .	240
LIST OF FIGURES . . . . .		242
LIST OF TABLES . . . . .		244
REFERENCES . . . . .		245

## SUMMARY

Navigable airspace is a finite asset that must be effectively planned and managed to support airport capacity. The largest single impediment in the routing of aircraft, as part of the aviation system, is noise. This research project has been initiated for the purpose of examining data bases to strategically plan for aircraft impact from a three-dimensional perspective. Aircraft routing pertains to both fixed as well as rotary wing aircraft operating in various modes, including takeoff and landing, high altitude and low altitude flyovers, and run-up.

Eight interrelated data bases were identified, inventoried and analyzed. These included geographic information systems (GIS), sound metrics, descriptors and noise prediction programs, land use, governmental regulations, airspace operational control measures, federal regulations and advisory circulars, census related information and environmental attributes. The characteristics and content of these data bases were reviewed individually as well as collectively, since the ultimate goal was to determine the feasibility of developing a comprehensive three-dimensional route impact methodology.

The investigation represents a new perspective on route analysis for aircraft. It vertically integrates all space that supports the biosphere including subsurface, surface and aerial planes. Three-dimensional "space use" planning is an important replacement for more traditional two-dimensional "land use" planning that focuses primarily on the surface or ground plane alone. The application of compatibility planning strategies to minimize aircraft routing impacts needs to be three-dimensional. Effective problem solving can only occur when the appropriate three-dimensional point of reference, is in place.

The results of this research indicates that a three-dimensional multi-sensory route impact system for noise is both desirable and feasible. There are several problems that must be overcome before it can be fully operational including:

1. Data Base Parity

The present data bases vary significantly in the quality and extensiveness of information. To maximize their contributions they must be elevated to a common level of parity, including filling the information voids where necessary.

2. Three-Dimensional Format

Existing information contained within these data bases are being defined either in two or three-dimensional points of reference. To be effective and consistent a three-dimensional format is necessary.

### 3. Multi-Sensory and Multi-Media Platform

Currently, the data bases are primarily operating within a visual and static platform. To enhance their utility will require that they also be translated into a kinetic and multi-sensory interactive medium. Aircraft need to be electronically simulated and kinetically interacting with various relational data bases.

### 4. Communication Interface

There is not a uniform language for communicating this information consequently not all data are translatable. A common interface and language is needed to standardize these important data bases in order to access multiple systems.

### 5. Accessibility

Information contained within these data bases range in terms of accessibility, depending upon the sponsoring agency. Due to their proprietary nature or classification, access to both public and private sector information is highly variable. These relational data bases must be more accessible to be effective.

### 6. Cost

There are necessary financial requirements to upgrade and expand existing bases. Those resources may not be forthcoming, which could diminish the overall effectiveness of implementing a three-dimensional route impact methodology.

These six factors, represent impediments to initiating a more responsive methodology for route noise planning and assessment. However they should not be looked upon as permanent roadblocks but rather as obstacles that can be overcome.

Lastly, the technology of GIS is a very attractive platform for relating data including the incorporation of noise. Geographically distributed sound data (i.e. geosonics) displayed both visually and acoustically is an important step toward a more virtual reality based reference system for avigational planning of aircraft. In the long run, GIS must be merged with other multi-media interactive based systems. The ultimate simulation, beneficial for aviation route planning among other applications, will be one that incorporates spatial, sensory and temporal elements.

**NASA/GT**

AIRCRAFT NOISE ROUTE IMPACT ANALYSIS



# **SECTION 1**

**INTRODUCTION**

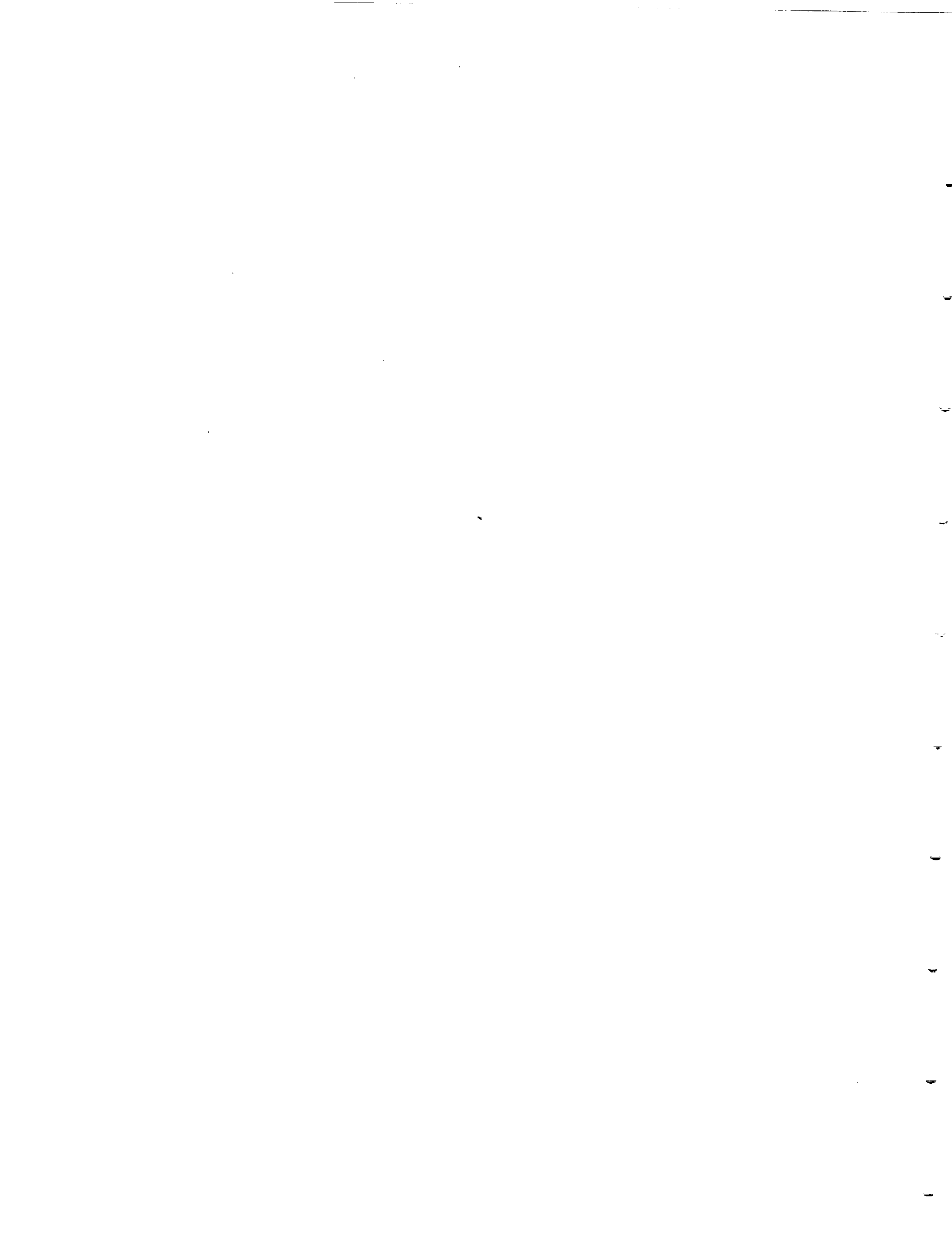



## 1.1 BACKGROUND

The strategic routing of aircraft through navigable airspace to minimize noise impact for both sensitive land uses as well as populated areas is essential in the airport planning process. Noise ranks as one of the leading factors affecting aircraft capacity, consequently it needs to be effectively addressed in order to maximize the airport and aviation system within the United States. Routing of aircraft at various assigned altitudes primarily from mean sea level (MSL) to 60,000 feet (FAA controlled airspace) for both civilian as well as military aircraft by the FAA must consider noise and associated impacts. Such issues are becoming of increasing concern because of population densities in more highly travelled air corridors, such as the northeast (e.g., Boston-New York to Baltimore-Washington). Today nearly 90% of the U.S. population now resides on approximately 10% of the land. However that does not mean the vast majority of the nation's land use, despite lower concentrations of people, should not also be protected and avoided when appropriate. Military flight operations, due to certain mission requirements, such as low level and nap-of-the earth flying are another part of the aircraft routing issue. This subject not only applies to both present technology aircraft but also future technology aircraft that will be subsequently part of the aviation system for the 21st century. To maximize the effectiveness of airspace as a finite asset requires the examination of all aircraft types, including both fixed and rotary wing vehicles, throughout the entire United States.

In order to determine an effective way for planning and evaluating aircraft routing, including noise impact, on a three-dimensional basis, requires the development of a comprehensive interdisciplinary data base.

## 1.2 OBJECTIVES AND TASKS

The major objective of this research project is to identify, inventory, characterize and analyze the various environmental, land planning and regulatory data bases, along with potential three-dimensional software/hardware systems that can be potentially applied in a noise impact assessment of any existing or planned air route. These routes of interest should include any geographical area of the United States including populated urbanized areas as well as sensitive environmental, historic, cultural, and recreational areas of interest. In support of this effort, a series of interrelated tasks were initiated that constitute a comprehensive approach to strategic routing of aircraft from a noise impact perspective (Figure 1.1). These nine tasks and their description are as follows:

### 1.2.1 Geographic Information Systems

Examine both existing software and hardware GIS-based systems to determine their potential application to three-dimensional route analysis. This will include examining relational data bases, their characteristics and applicability.

## 1.2.2 Sound Metrics and Descriptors and Noise Prediction Programs

Review the prevailing sound metrics and descriptors used for characterizing environmental noise impact, including dBA, LEQ and DNL, etc. Assess the various noise prediction programs including the Integrated Noise Model Version 3 (Data base No. 10), NOISEMAP (Noise Exposure Model, 6.0), and Heliport Noise Model, Version 1, and their potential applicability to GIS as well as other graphic/multi-media systems.

## 1.2.3 Land Use Data Bases

Identify and evaluate the present land use profiles for both existing and projected land uses for the United States. Determine their compatibility in terms of classification, scale, coverage, accuracy, availability and computer applicability.

## 1.2.4 Governmental Regulatory Data bases

Inventory present data bases that regulate land use impacts (i.e. environmental noise) at the local and state government level. Determine the characteristics of such information systems, including their computer applicability.

## 1.2.5 Airspace Operational Control Measures

Review and inventory aircraft-related operational control measures that pertain to airspace within the United States. Such operational controls should relate to land compatibility. Determine the extent to which these measures can be developed spatially in order that they be effectively integrated with evolving GIS software for aviation planning.

## 1.2.6 Federal Regulations and Advisory Circulars Pertaining to Route Analysis

Inventory and review all federal regulations and advisory circulars that pertain to aircraft-related route procedures and environmental land use compatibility. Included would be FAR Parts 36, 77, 150 and 161 and any data bases that may have been compiled related to the application of these regulations and advisory circulars.

## 1.2.7 Census, Demographics, and Real Estate Based Analysis

Review U.S. census of population, housing, business, manufacturing, and real estate data bases for specific attributes that may have applicability to a route impact analysis. Included would be real estate appraised property values along with non-resident population information.

### 1.2.8 Environmental Attributes

Identify and inventory all physiographic environmental features (e.g. wetlands, endangered species, archaeological) related to environmental impact and assessment methodologies and their applicability to route analysis.

### 1.2.9 Feasibility of Developing a Comprehensive Three-Dimensional Route Impact Methodology

Integrate the results of these eight other subtasks to determine the feasibility of performing a three-dimensional route impact analysis that uses multi-senses (e.g. vision and sound) in a fixed frame and kinetic medium.

## 1.3 METHODOLOGY

For each of these tasks, a specific methodology was developed to research data bases. A background description was prepared along with an analysis of their applicability, comprehensiveness, and future use of each data base. The importance and interrelationship of these data bases were also reviewed in terms of how they addressed the goal of developing a three-dimensional route analysis system for aviation related noise. A glossary of terms and selected references was prepared, as well as an evaluation matrix characterizing the research conducted as part of these tasks.

To date, there has not been a comprehensive investigation of the subject conducted. This undertaking required an interdisciplinary approach to the subject and the proposing of a three-dimensional impact assessment model that represents a new perspective on route analysis for aircraft. This perspective featured a spatial approach which included understanding the subsurface, surface, and aerial characteristics of our biosphere, that contains the navigable airspace in which aircraft are permitted to operate and influence the environment. By moving into the three-dimensional multisensory world, this challenging project provided an opportunity to consider the magnitude of aviation and the effective need for space use rather than land use planning. Two dimensional points of reference need to be replaced by a more visionary three-dimensional examination of space as a finite and critical asset for more effective planning, particularly as the 21st century approaches. Aviation as a mode of transportation, is the only one that offers all three degrees of freedom for exploring the dimensionality of space.

Space as an asset must be thoroughly explored and adequately protected as the United States positions itself in the competitive world economy for the year 2000 and beyond. It is a finite and limited resource which is a non-renewable asset that must be carefully planned and managed. Planners must move away from this two-dimensional constrained approach of land use planning and meet the challenge and need for three-dimensional space use planning. This methodology will assist in achieving this goal of a new spatial reference for more productive planning.

#### 1.4 ACKNOWLEDGEMENTS

A dedicated team of researchers, reflecting a multitude of disciplines were involved including engineering, urban planning, geography, computer science, landscape architecture, and acoustics. In addition to the professional assistance and competent insight provided by the other principal investigators, Mike Rowan and Krish Ahuja, the graduate students supporting this research project performed in a laudatory manner. These individuals included Troy Russ, Andreas Georgiopoulos, Katherine Bragdon, Paul Duda, Prashant Parikh, Kent Ahrens, Matt Taylor and John McShane. I would also like to thank NASA Langley personnel in the Structural Acoustics Branch for their confidence, patience, and commitment to a research area that was previously uncharted "spatially" - specifically Dr. Clemans A. Powell, the technical project monitor. Lastly, I want to acknowledge Vicky Mathis, my administrative assistant who provided strong support in preparing this report.

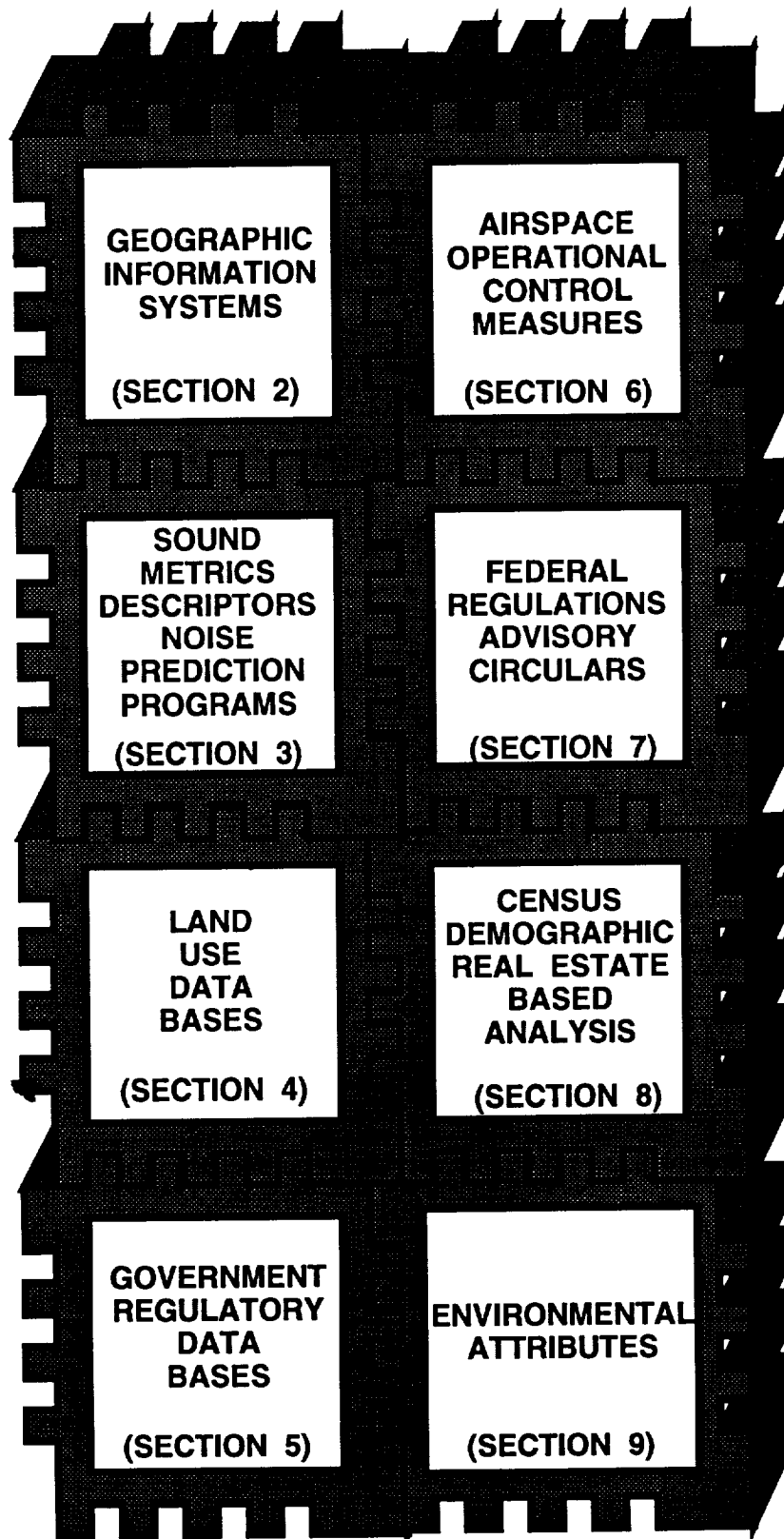

Figure 1.1 Interrelationship of strategic routing of aircraft tasks for developing a three - dimensional methodology.



**NASA/GT**

AIRCRAFT NOISE ROUTE IMPACT ANALYSIS



# **SECTION 2**

**GEOGRAPHIC  
INFORMATION  
SYSTEMS**

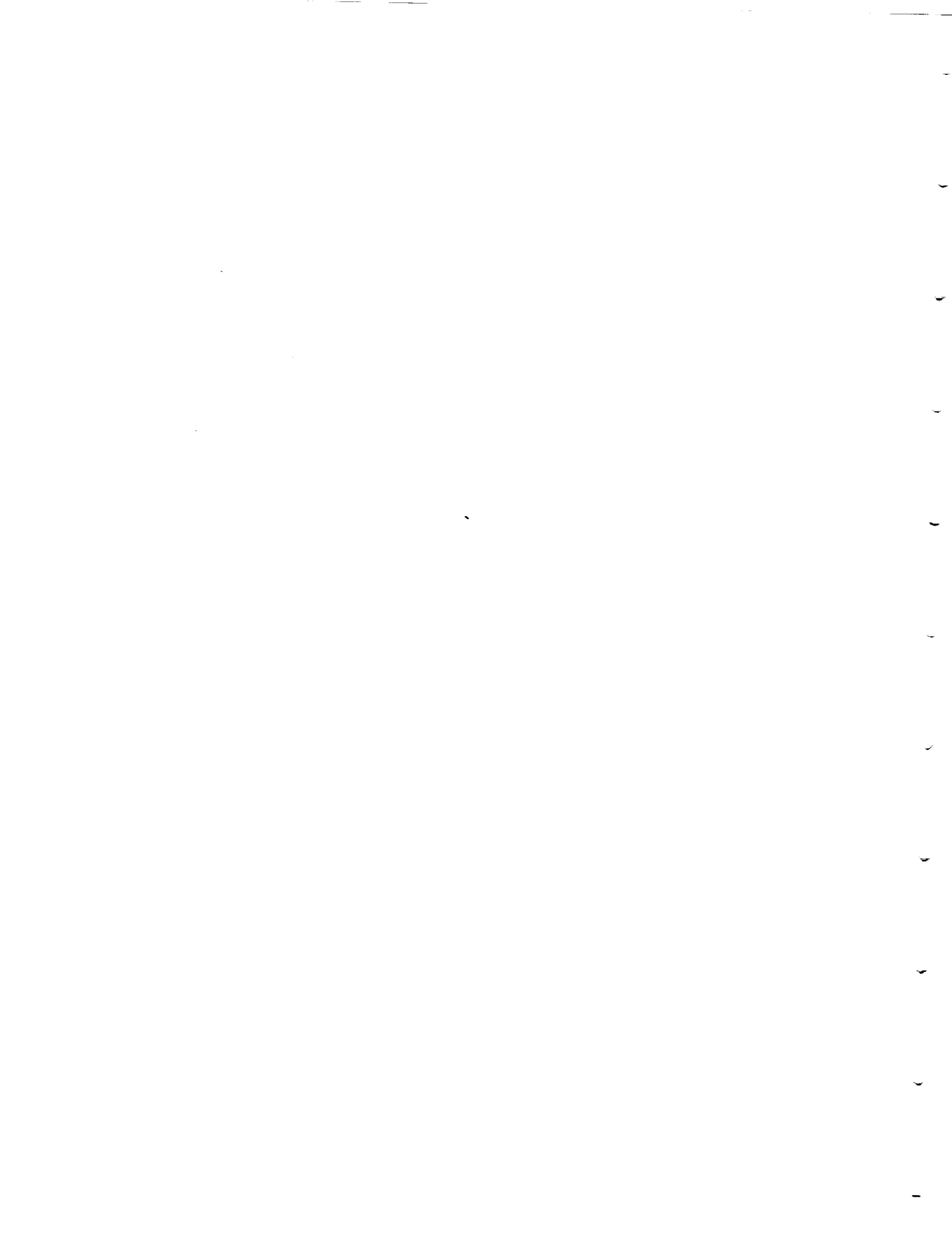



## 2.1 INTRODUCTION

### 2.1.1 Purpose

The purpose of Section 2 is to examine both hardware and software components of existing Geographic Information Systems (GIS) to determine their potential application to three-dimensional route analysis. Subsection 2.3 examines the ability of present GIS to relate spatial data including noise contours and census information to airspace planning and route analysis.

### 2.1.2 Background

A GIS manages information associated with specific spatial coordinates, or spatial data. The term GIS refers to a hardware and software system along with associated spatial data bases. The spatial data in a GIS consist of three elements: points, lines, and areas (Figure 2.1). A point represents one specific location in space. While a line connects two points, and an area encloses a series of three or more points. The glossary of GIS terms is contained in Appendix A.

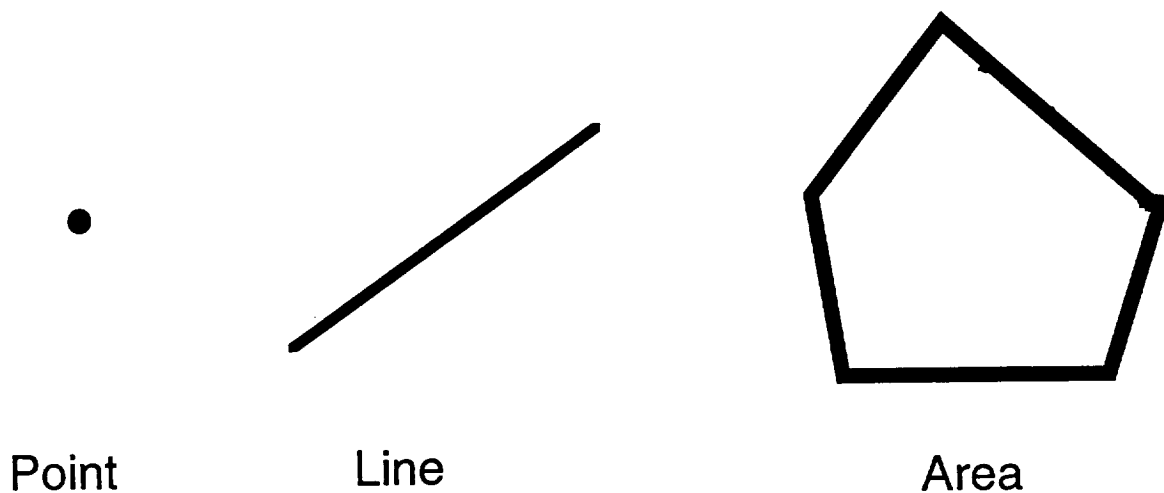

Figure 2.1 GIS elements.

Each set of information elements stored in a GIS might be visualized as a series of transparent overlays placed over a base map (Figure 2.2). A GIS can display any number of overlays at one time. These multiple overlays can be input from a variety of media such as floppy computer disks, compact digital disks, digital tapes, and paper maps through peripherals such as disk drives, digitizers, and scanners.

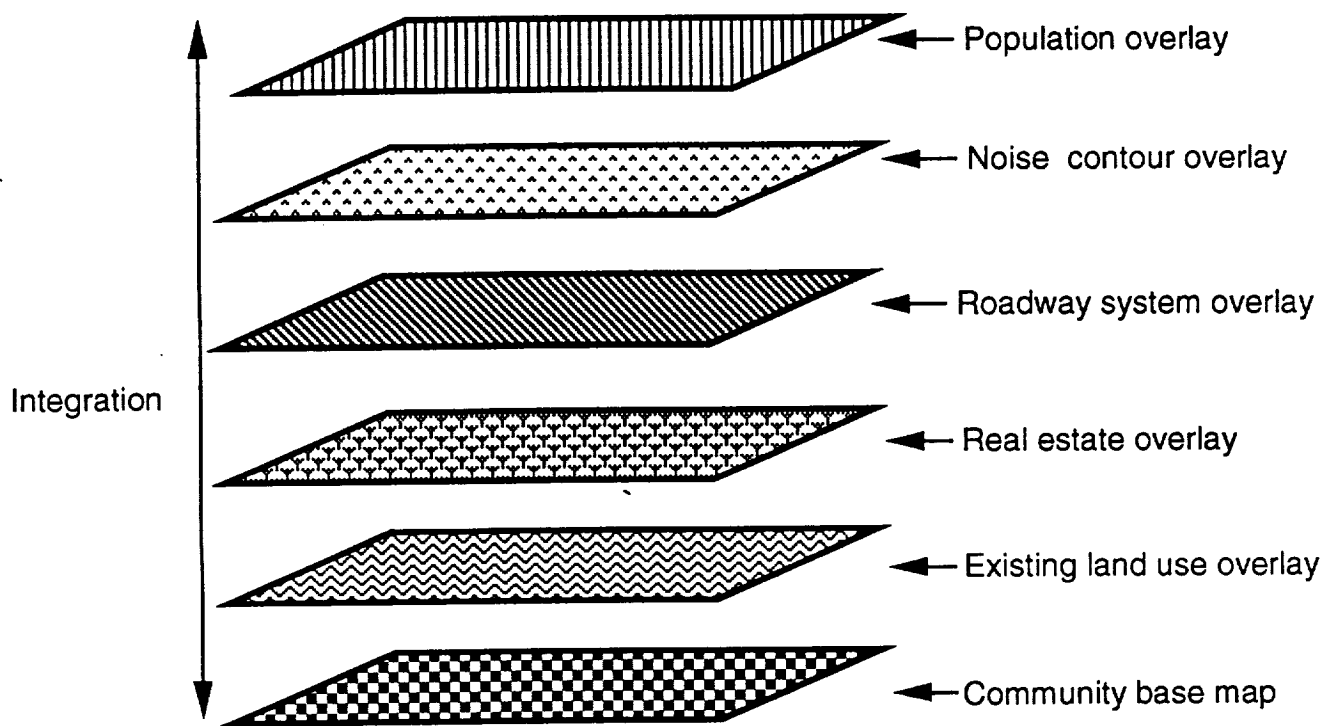
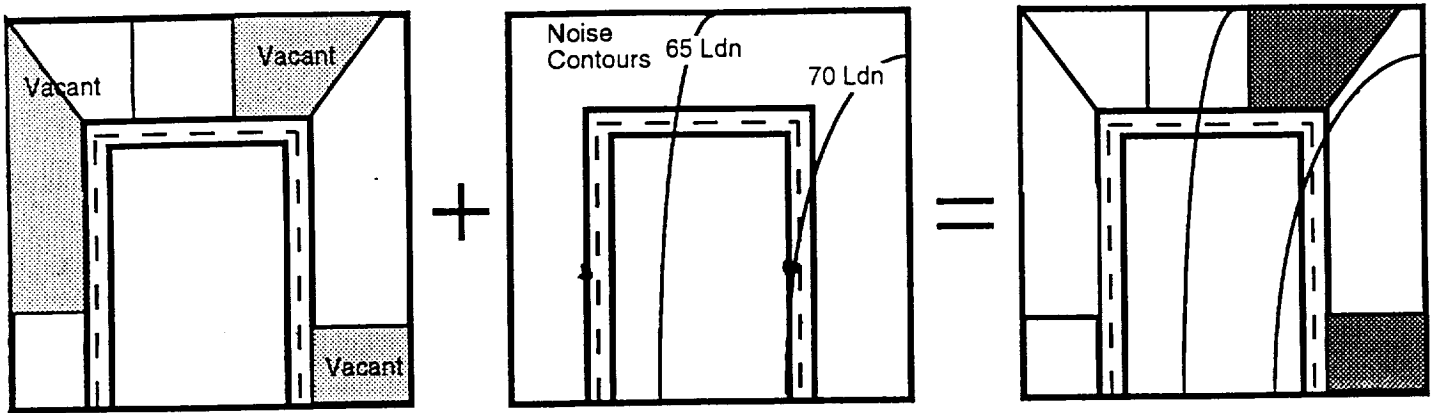

Figure 2.2 Typical GIS overlays.

More important than the display capability is the ability to perform analyses that interrelate these overlaid data layers. The key element of a GIS is that it can manage spatial data while preserving the positional relationships among spatial elements. Preserving this relationship enables a GIS to perform complex spatial analyses. For example, a GIS could combine land use and noise contour overlays to identify and display all vacant land within a certain noise contour (Figure 2.3). An airport authority might want to know the amount of vacant land in an area affected by the proposed expansion of their airport. Identifying the vacant parcels within specified noise contours could provide the airport authority with an estimate of the amount of undeveloped land and their ownership for a proposed noise abatement plan. This information would then allow the airport authority to determine the number of acres that might be needed to be acquired or sound insulated to minimize aircraft noise exposure in a specific residential area.



Land Use Overlay  
showing vacant land  
and parcel  
boundaries

Noise Contour Overlay

Combination of Overlays  
highlighting vacant land  
within 65 Ldn noise contour  
and 70 Ldn noise contour

Figure 2.3 Example of noise overlay analysis.

A GIS can provide significant cost and time-saving benefits to the user in that these systems offer responsive answers to complex analysis problems. For example, a community development agency might use a GIS to investigate aircraft noise levels around a possible investment site. The agency might discover that certain climatic conditions and air traffic patterns which dictate that flights from an expanded airport be routed near the site. This problem may not be readily apparent from existing airport documents, and it could alert the agency that the site might at some time be eligible for acquisition in a buy-out program with financial assistance from the federal government on some cost matching basis.

GIS are used in a variety of applications both in the public and private sectors. For example, municipal planning offices commonly use these systems to manage and store zoning information. Engineering departments apply GIS to inventory and update infrastructure layouts. Transportation engineers use a function of GIS known as network analysis to model road and highway networks and corresponding data. City planners commonly apply a function of GIS known as buffer analysis for identifying and analyzing incompatible land uses. In air space planning these functions can be used to model air traffic control corridors and flight paths. Figure 2.4 shows some typical airspace planning GIS overlays. The overlays shown in this example include a noise grid and a zoning map.

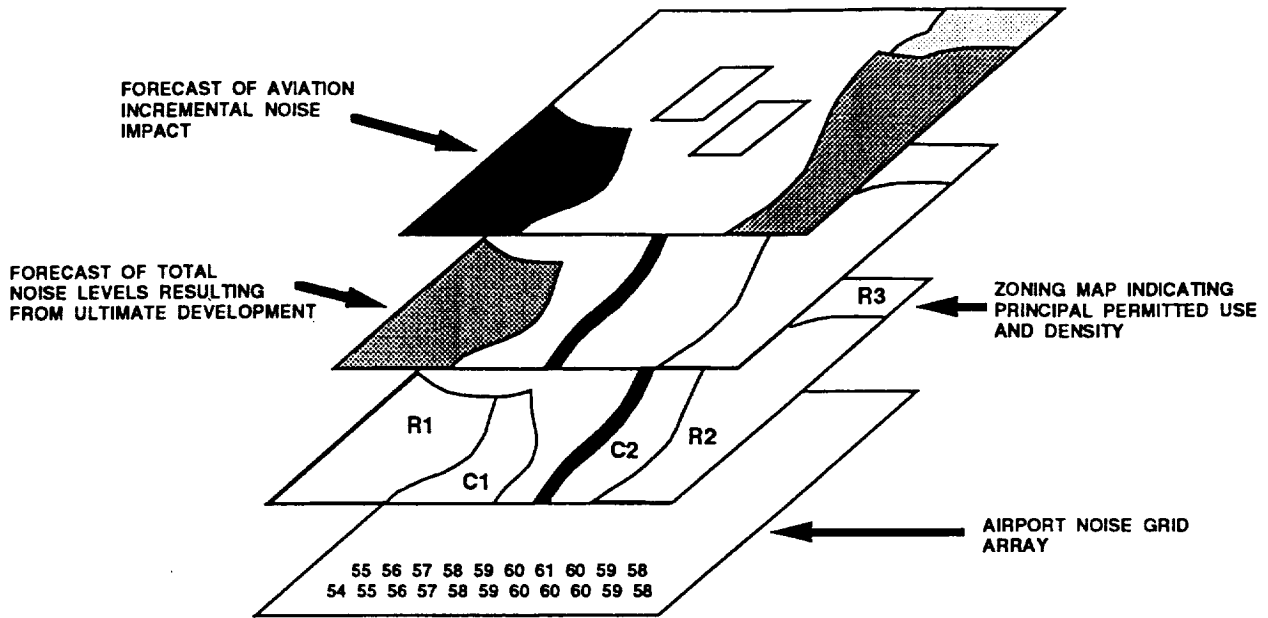

Figure 2.4 Typical airspace planning overlays [2.1].

GIS systems usually employ one of two data structures. These structures, known as the raster data structure and the vector data structure, refer to the way in which the data is stored (Figure 2.5). The raster data structure can be compared to a fine grid covering the mapped surface. Each cell of the grid contains an item of information referring to that particular location. Examples of a raster system include photography and satellite imagery. Instead of a grid-like structure, data items in a vector system are stored as points, lines, and polygons. In contrast, vector data systems include contour lines on topographical maps and census blocks with population, housing, and economic data. A series of noise contours could be classified as part of a vector based system.

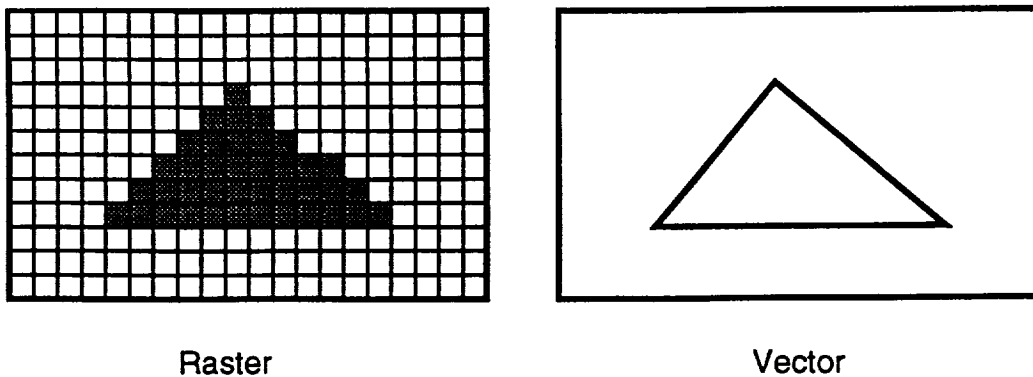

Figure 2.5 Raster and vector data structures.

The topological data structure is also commonly used. This data structure is a variation of a vector based system allowing multiple layers of data to be compressed into a single layer. Although computationally complex, it provides for efficient storage of data.

### 2.1.3 Interrelationship

Developing a system for airspace planning requires the assimilation of a large amount of data from a wide range of diverse sources. A GIS is an important tool that can assist in combining data from this whole range of sources for spatial analysis. Such a GIS could be developed for analyzing aircraft noise in conjunction with ground information data bases including census information, land use, terrain models, governmental regulations, operational controls, and environmental restrictions. GIS are particularly useful for these applications because of their ability to combine and analyze large quantities of data quickly and efficiently.

Table 2.1 shows the interrelationship between a GIS and the next seven sections of this report. A GIS is closely related to every other item because GIS is the vehicle or platform by which they can be spatially related to one another. The level of relationship between geographic information systems and the other items is major in most instances (i.e. R1), and no minor relationships are identified.

Table 2.1 Interrelationship between geographic information systems and other sections.

<u>Section</u>	<u>Name</u>	<u>Level of Relationship</u>
3	Sound metrics and descriptors	R1
4	Land use data bases	R1
5	Government regulatory data bases	R1
6	Airspace operational control measures	R2
7	Federal regulatory and advisory circulars pertaining to route based analysis	R1
8	Census, demographic and real estate based analysis	R1
9	Environmental attributes	R1

- R1 - Major Relationship
- R2 - Moderate Relationship
- R3 - Minor Relationship
- R4 - No Relationship

One of the more recent developments in GIS technology is the capability to import sets of data from a multitude of sources. Many of the data bases mentioned in this report are being produced in standard formats so that they can be reality utilized in a variety of GIS.

#### 2.1.4 Relevance

The use of geographically based spatial information applied to airport planning did not occur until the 1980s. For example, one of the earliest uses of GIS for assessing airport noise was applied at Atlanta Hartsfield International Airport. This study, which began in 1983 assessed the aircraft activity over an adjacent county (DeKalb County, Georgia) [2.2]. It used a GIS to model current and projected noise contours in relation to land use, population, noise complaints, and income levels. A series of graphic based maps representing several variables were produced, including household income by census tract and annual average noise contours (Figure 2.6).

In recent years several airports have developed geographical data bases in response to the Federal Aviation Regulations (FAR) Part 150 process [2.3]. These systems, which store selected demographic, land use, and noise data, are becoming more common today. Such GIS based systems are now being developed by a multitude of air carrier airports to assist them in airport planning, engineering, and design. These data bases are usually limited geographically to the airport and the immediately adjacent communities.

Several computer models have been produced for airspace planning, but these models do not have the data management capabilities of a GIS. The Federal Aviation Administration (FAA) has approved an aircraft noise model (Integrated Noise Model 3.10) that estimates average noise levels and provides a graphic representation of noise contours on the ground surface around airports [2.4]. Working with the FAA the Florida Department of Transportation produced an airspace management system that is being applied at selected airports throughout the state of Florida [2.5]. The Florida model is capable of accessing the FAA Integrated Noise Model, drawing noise contours at selected elevations, and displaying approach and departure paths. Figure 2.7 is an example of output from this 3-D Airspace Analysis Model used at Orlando International Airport for the purposes of height and clearance analysis. Using a computer aided design software package this graphic provides a three-dimensional perspective where approach and departure paths are displayed along with the imaginary surfaces. By combining the geographical data bases with other computer aided design modeling systems, a powerful planning tool can be developed.

# DEKALB CO.

## ATLANTA INTERNATIONAL AIRPORT NOISE STUDY

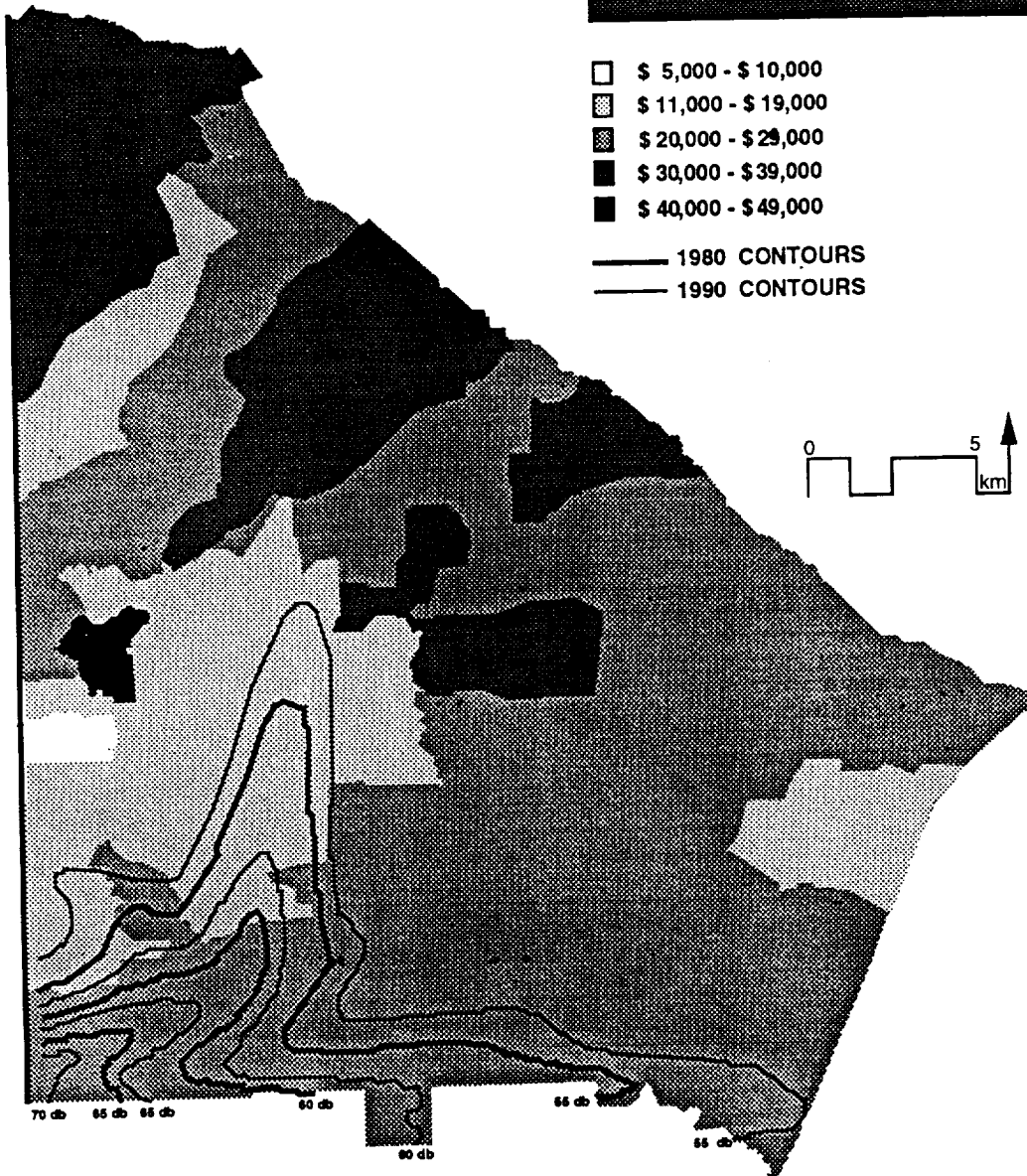

**ANALYSIS:  
INCOME / 1980 & 1990  
NOISE CONTOURS**

Figure 2.6 Average household income and aircraft noise contours:  
DeKalb County, Georgia [2.2].

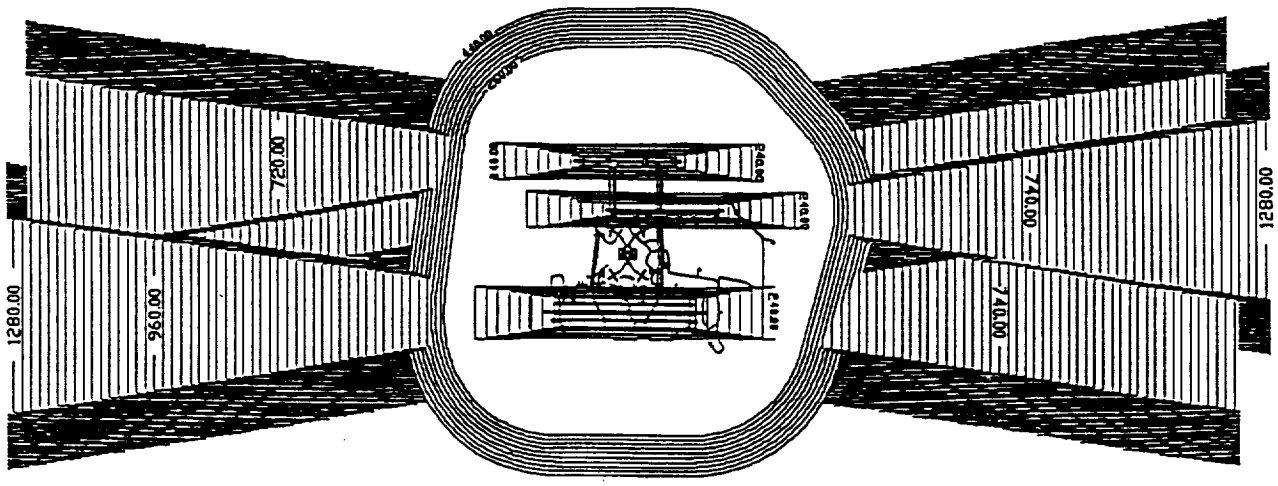

Plan View

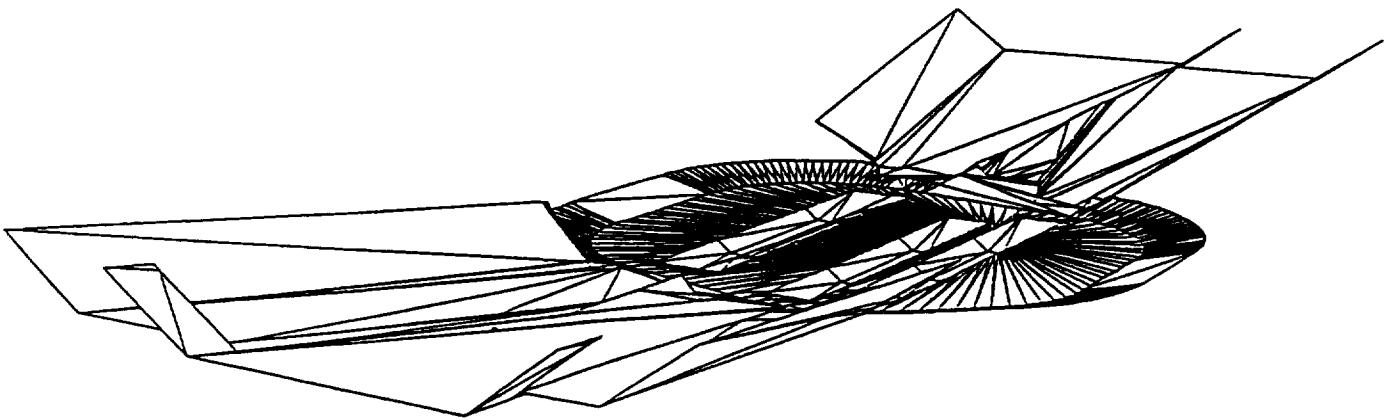

Perspective View

Figure 2.7 Computer generated three-dimensional airspace surface analysis (FAR Part 77) program: Orlando International Airport [2.6]



## 2.2 METHODOLOGY

### 2.2.1 General

An investigation was conducted to determine the current state of GIS technology. Selected GIS companies were requested to answer a series of questions pertaining to the capabilities of their systems. Appendix B includes a list of the questions in the survey and a summary of the results. Figure 2.8 presents the nine GIS vendors included in the investigation.

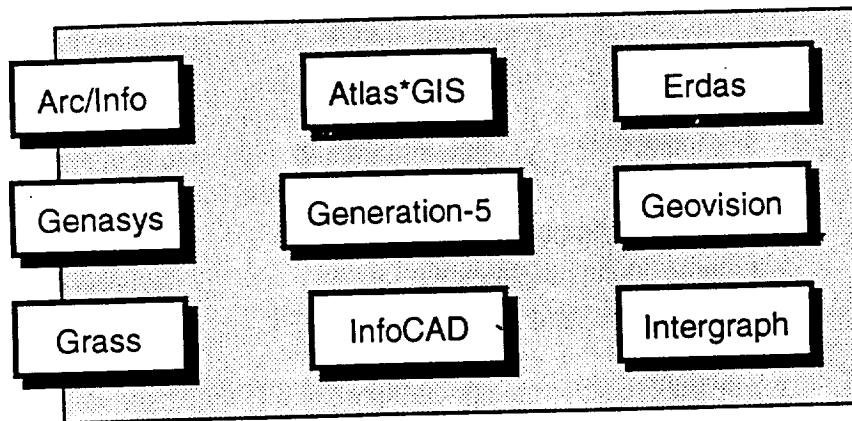

Figure 2.8 GIS vendors surveyed.

### 2.2.2 Specific

The nine vendors designated above were chosen due to their visibility and market share. These nine do not comprise a complete list of GIS based companies and products, but rather a representative sample of current technology and capabilities that are recognized within the industry and available in the marketplace.

Material pertaining to these GIS was obtained through correspondence by mail, telephone inquiries, and discussions at professional conferences. The names of the specific representatives contacted are included with the investigation results in Appendix B. Not all of the manufacturers were able to supply answers to every question, and some of the answers were influenced by the interpretation of the question by the representative. Even though the individual answers may be less than complete in some instances, the matrix does provide a meaningful overview of the current capabilities of GIS.

## 2.3 FINDINGS

Geographic information systems are a developing technology that began in the late 1960s. The state of the art is constantly evolving. A short time ago GIS manufacturers were dealing with problems that now have been solved in even the least sophisticated systems. For example, in the past, GIS were not designed to handle multiple coordinate systems. Now almost every system can change from one coordinate system to another. GIS also were incapable of displaying terrain models. Now most systems are designed to display topography. Figure 2.9 shows some common GIS capabilities.

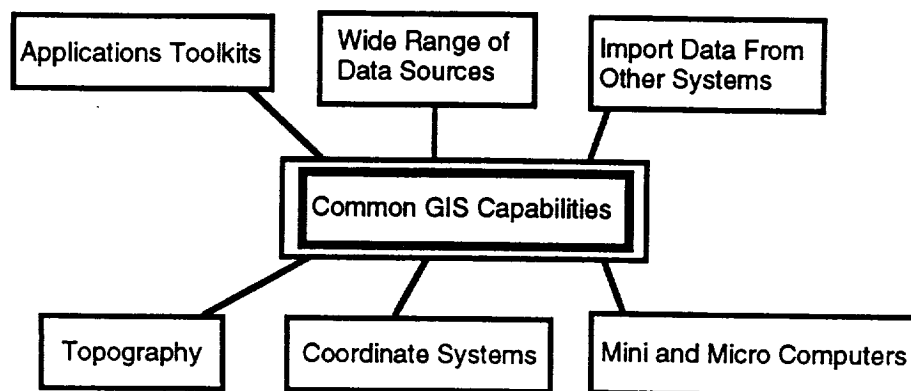

Figure 2.9 Some common GIS capabilities.

Most GIS packages are capable of reading data from a wide range of sources, such as the U.S. Bureau of the Census TIGER (Topologically Integrated Geographic Encoding and Reference) files, the U.S. Geological Survey Digital Line Graphs, and the AutoCAD Digital Exchange Format [2.7, 2.8, 2.9]. The ability to input data from a variety of sources is especially important in an area such as airspace planning where many different types of data are pertinent and must be merged to obtain a clear understanding of the issues.

This ability to import data from other systems is also an important development in GIS technology. When combining data from a broad range of sources, data stored in one system's format might need to be combined with data of another format. Many systems today allow data to be imported in an external format and then converted to the system's own internal format. Such a capability is essential when aircraft activity including noise information is needed to be related to other data bases from other platforms.

GIS can run on a mini-computer work station or personal computer. The larger

memory of a mini-computer allows for faster analysis of large volumes of data. Higher graphic resolution also makes a mini-computer more desirable, however these work stations are more costly than personal computers. The quality and degree of resolution depends more now on the hardware than software since most vendors are now offering graphic resolution packages that are approaching comparability. This geographic representation of mapped data is also now available in color.

Most GIS provide the user with a toolkit for writing personalized applications. These toolkits are valuable because they allow more experienced users to set up custom systems which eliminate manual repetition of complicated procedures. Toolkit commands are often structured much like the commands of common programming languages.

One problem that requires resolution before developing a large scale airspace planning model involves the significant volume of data that must be analyzed in airspace planning. This investigation uncovered different responses to this problem, but manufacturers agreed that computer analysis capabilities could limit the ability of the software to perform such large-scale analyses.

Existing GIS packages available on the market can utilize what is referred to as a relational data base. The system can allow virtually an unlimited amount of data to be stored. When a particular attribute file is queried, other attribute files related to the original datum are simultaneously accessed. The original query activates the second data file. Likewise, other attribute files can be linked to the second data file. The result can be a continuous series of related and linked data files. This means that there is really no upper limit to amount of data that can be stored. A problem that has to be resolved with this potentially large amount of data is the speed at which a particular package can retrieve and utilize the data. Vast amounts of information can be stored but the question is how fast can the system move among the stored data? How fast can the system search and retrieve the data for a particular type of analysis? The speed at which the particular system performs this task could be a major constraint to the GIS proposed in this report.

Perhaps the most important capability of a GIS used for aircraft planning is the ability to perform three-dimensional analyses. GIS vary in their ability to display data in three dimensions. This investigation found no current system capable of analyzing such data. GIS manufacturers have tended to focus on data which varies in only two dimensions while ignoring the third dimension.

Airspace planning involves three dimensions for it to be effective. Since data regarding the flight of aircraft varies spatially, the data structure internal to a GIS must be able to analyze data not only as it varies over the ground surface but also in the vertical dimension. Only recently have GIS manufacturers begun to investigate developing a data structure with the ability to perform a spatial analysis.

Most GIS manufacturers claim to have a volumetric capability, but the data cannot

be analyzed spatially. These programs merely store an elevation value as one attribute of the ground map, and this elevation value can be viewed from various projections. Several manufacturers are interested in developing capabilities which will allow analyses of spatial data in three dimensions, but these capabilities are off in the future.

However, there are ways in which one might adapt a GIS to perform a volumetric analysis. For example, one conceptual way is to use a series of data layers representing different elevations (Figure 2.10). Each data layer would represent a horizontal spatial "slice". The slices could be stacked to simulate a continuous space. As an aircraft would penetrate each slice, new information would be displayed pertaining to that elevation. By freezing these layers one could produce a spatial history of route impacts on the ground.

A kinetic GIS would permit aircraft and their relational data bases move through navigable airspace over selected corridors of interest. At the appropriate points in time and space, the flight could be suspended or frozen to analyze certain ground attributes (e.g., noise generation, population and residential structure impact). This capability is not readily available at the present time.

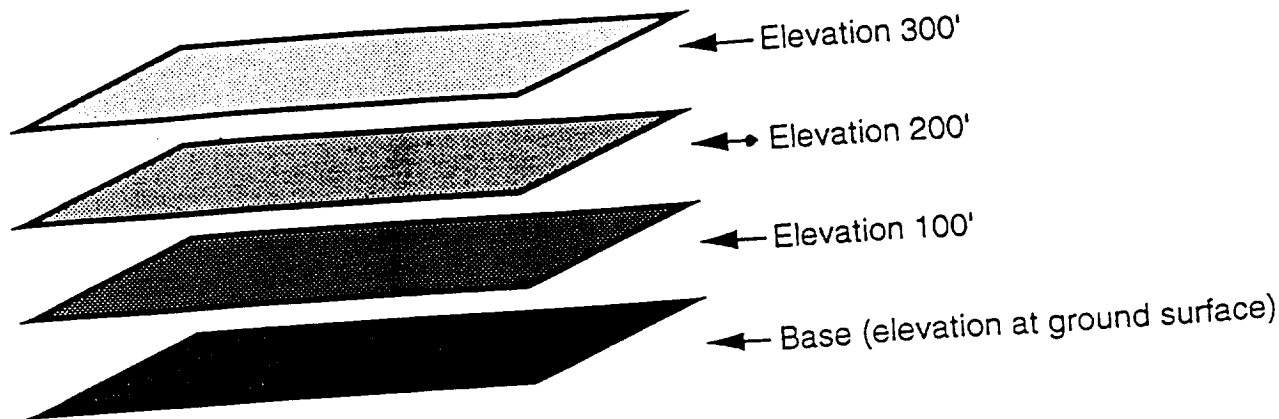

Figure 2.10 A possible three-dimensional GIS structure.

The future trend in GIS seems to be the development of spatial analysis capabilities, but more complex data structures are required in handling truly three-dimensional data. Programmers with several GIS manufacturers are presently trying to develop capabilities for analyzing such data. For example, these manufacturers are interested in developing a system to store data in cubic units similar to grid cells. Each of these units could store data. A volume of space could be modeled as a volume filled with these tiny cubes (Figure 2.11).

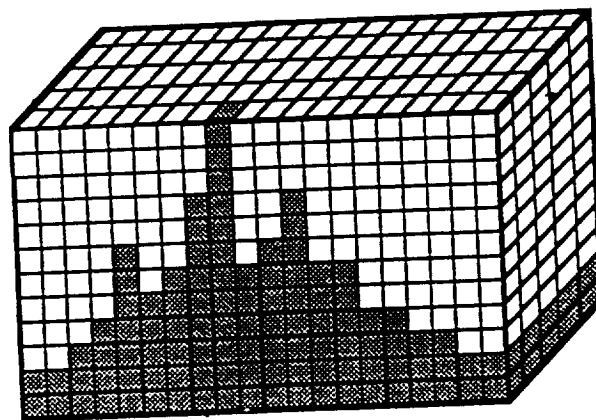

Figure 2.11: A volumetric three-dimensional GIS data structure.

Technologies for visualizing dynamic volumetric entities have been developed in the past few years. These visualization techniques are an important step towards

developing a dynamic spatial GIS. Although these systems cannot manage spatial data as a GIS can, they are capable of displaying three-dimensional images that change over time, unlike conventional static systems. The combination of dynamic visualization technology with a GIS will be a significant step towards the type of GIS desired for airspace planning.

Over the past few years many significant problems have been overcome in GIS development, including flexible coordinate systems, importing data from a wide range of data sources including other GIS systems, and displaying topography. Developing a dynamic three-dimensional analysis capability is one of the current problems being addressed.

## 2.4 CONCLUSION

### 2.4.1 Applicability

GIS provide valuable tools for managing spatial data. Since a large amount of spatial data is needed for comprehensive airspace planning, GIS programs are at least one appropriate technology. Continuing developments in the GIS field will lead to more complete spatial analysis capabilities in the future.

### 2.4.2 Comprehensiveness

This study is not an attempt to provide a comprehensive report on the capabilities of all GIS programs. Nine GIS based vendors were selected to be included in the investigation. Since these systems were selected on the basis of their national visibility, the information obtained from the investigation appears to be representative of the types of GIS capabilities available in common programs. Refer to the section entitled "Selected Readings" for information about other GIS programs. It should also be noted that this study made no attempt to compare the claims of GIS companies to the actual capabilities of their products. Consequently, the utility of these survey results is heavily dependent upon the accuracy of the vendors' responses.

### 2.4.3 Future

GIS technology is continuously expanding. Capabilities common today did not exist a short time ago. Trends indicate that GIS technology will continue to expand, and capabilities uncommon today will soon be typical of all systems. A true three-dimensional relational data base applicable to airports and airspace using GIS as the platform is possible in the future, but does not yet exist.

**NASA/GT**

AIRCRAFT NOISE ROUTE IMPACT ANALYSIS



# **SECTION 3**

**SOUND METRICS  
MODELS  
PREDICTION PROGRAMS**





## 3.1 INTRODUCTION

### 3.1.1 Purpose

The purpose of this section is to review the prevailing sound metrics, descriptors, and noise prediction programs for characterizing noise impacts including dBA, LEQ, and DNL that are recognized by the Federal Interagency Committee on Noise (FICON) [3.1]. The specific noise prediction programs include the Integrated Noise Model Version 3 (Data Base No. 10), NOISEMAP (Noise Exposure Model, 6.0) and Heliport Noise Model, Version 1 [2.3, 3.2, 3.3].

### 3.1.2 Background

The physical measurement of sound in a community setting is a relatively new phenomena. Although acoustical terminology and the development of national standards for sound began to appear during the early part of this century, noise instrumentation for outdoor measurement purposes did not become available until the late 1920s. The first series of outdoor noise measurements were initiated in New York City, in conjunction with Bell Laboratories. Equipment used for this first community noise survey was laboratory based instrumentation. It was another 30 years before any methods were adopted to predict environmentally generated noise [3.4].

In the United States, the primary interest in modeling noise involved military related aircraft. This initial work was prepared for the U.S. Air Force in the early 1950s, to determine the sound level of aircraft in the vicinity of military airfields. Airfield planning for noise compatibility purposes had begun to be a concern of the Department of Defense. Community growth and encroachment around many installations began to be recognized as a threat to the military mission. This had been one of the basic themes of the Doolittle Aviation Commission Report, submitted to President Harry S. Truman in 1948; the need for more effective airport related planning [3.5].

Initiated by the Air Force and subsequently by the FAA, computer based models for predicting aviation noise have evolved rapidly. Today, there are two recognized aviation based noise models for fixed wing aircraft; one civilian and one military. The military version, NOISEMAP is used throughout the Department of Defense by all branches of the service for airport master planning and environmental assessment and review. In contrast, the INM, developed for the FAA, is used for most civilian related airport studies.

### 3.1.3 Interrelationship

Appropriate sound metrics, descriptors, and aircraft related noise prediction models profoundly impact the strategic routing of aircraft. Consequently, they have an important relationship with the tasks described in the other sections. These specific relationships

and their degree of importance are presented in Table 3.1.

Table 3.1. Interrelationship of sound metrics and descriptors and other sections.

<u>Section</u>	<u>Name</u>	<u>Level of Relationship</u>
2	Geographic information systems	R1
4	Land use data bases	R1
5	Governmental regulatory data bases	R1
6	Airspace operational control measures	R1
7	Federal regulations and advisory circulars pertaining to route analysis	R1
8	Census, demographics and real estate based analysis	R2
9	Environmental attributes	R1

R1 - Major Relationship

R2 - Moderate Relationship

R3 - Minor Relationship

R4 - No Relationship

There appears to be a very positive relationship with most of the other sections as noted by the high ratings (i.e. R1).

#### 3.1.4 Relevance

Noise modeling for aircraft operations in navigable airspace can provide the physical footprint of aviation activity throughout the United States. Comparisons of these alternative routes and their relationship with human settlement patterns will result in valuable data sets for assessing impact and determining future courses of action. Since the Federal government has accepted the Day-Night Average-A Weighted Sound Level (DNL) as the cumulative noise exposure metric for assessing all transportation noise impacts including aircraft, the process of analysis and planning has been facilitated [3.1].

The Federal Interagency Committee on Noise (FICON) was chartered to review specific elements of federal agency procedures for the assessment of airport noise impacts and to make appropriate recommendations to the President. Federal government representatives involved in this recent year long review included the Departments of Transportation, Defense, Justice, Veterans Affairs, Housing and Urban Development, the Environmental Protection Agency; and the Council on Environmental Quality [3.1].

## 3.2 METHODOLOGY

### 3.2.1 General

The acoustical terminology in place today has been described by some as the world of alphabet soup since there appears to be sound descriptors and metrics available for every possible occasion. Often this has led to considerable confusion, unnecessary duplication and redundancy, institutional conflicts and territorial wars over what should be consensus and accepted jargon. The methodology employed to describe relevant sound descriptors and metrics was to examine consensus documents or reports prepared to establish acceptable environmental noise terminology pertaining to aviation as well as examining the primary noise prediction models. Consequently, the emphasis is on brevity, professional and scientific agreement, rather than acoustical esoterica.

### 3.2.2 Specific

The U.S. Environmental Protection Agency, Office of Noise Abatement and Control (ONAC) was established as a result of the Noise Control Act to be the federal clearinghouse for noise related activity. Although their role has diminished in recent years, primarily due to budgetary cuts and personnel shortages, they did establish acceptable terminology as part of the preparation of the levels document for Congress [3.6]. This publication became the primary source for developing the appropriate descriptors and sound metrics to be included in the findings. A similar process was employed to determine what noise models should be examined, and that was based on acceptability by FICON for predicting airport and aircraft noise impact. There are however many other existing models that describe community noise impact from an airport and/or aircraft perspective including ALAMO, ANOPP, ROTONET, and TRAC.

## 3.3 FINDINGS

### 3.3.1 Sound Descriptors and Metrics

The following descriptors and metrics were examined as they particularly related to aircraft and airport noise impact assessment and planning.

#### 3.3.1.1 A-Weighted Sound Level - dBA

The A-Weighted Sound Level is abbreviated as dBA, and whose symbol is  $L_A$ , expressed in decibels refers to the A scale of the frequency response curve. This A scale weighing network has been selected by the EPA as the preferred sound descriptor for assessing the impact of environmental noise [3.6]. This descriptor, dBA, indicates the magnitude of a sound at a specific position and point in time and is used to describe aircraft noise.

### 3.3.1.2 Sound Exposure Level - SEL

The Sound Exposure Level abbreviated as SEL whose symbol is LAE or LAX, usually represents the time integral of the mean square A-weighted sound pressure level, dBA, normalized to one second. It can be thought of as the accumulation of sound energy over the duration of an event, where the duration is defined as the time when the A-weighted sound level exceeds a threshold, typically above the ambient. The SEL provides a comprehensive way to describe an aircraft noise event, which can be used for aircraft noise exposure modeling.

### 3.3.1.3 Equivalent Continuous Sound Level - LEQ

The Equivalent Sound Level, abbreviated as LEQ or  $L_{eq}$ , represents the accumulation of A-weighted sound levels integrated over a particular time duration. This time period can vary and typically involves a continuous one hour  $L_{eq(1)}$ , eight hour  $L_{eq(8)}$  and/or twenty-four hour  $L_{eq(24)}$  interval. In most environmental noise studies associated with aircraft the time period of interest covers 24 continuous hours, however hourly periods are often used as a basis to perform other analyses.

### 3.3.1.4 Day Night Average Sound Level - DNL

The Day Night Sound Level, abbreviated as DNL whose symbol is  $L_{dn}$ , represents the equivalent sound level (LEQ) for a 24 hour period with a 10 dBA penalty added to the nighttime. Nighttime hours cover the time from 10:00 p.m. to 7:00 a.m. This addition for nighttime related noise activity is specifically designed to account for the intrusiveness of noise during this period, including its potential impact on sleep [3.1]. Aircraft related noise occurring during the evening and nighttime hours would be a potential noise source that could impact the community. The DNL metric is used as the principal means for describing long term noise exposure of both civil and military aircraft operations, usually based on an annual average DNL.

There are many other metrics in use to describe sound which may come into play, depending upon the specific type of analysis and sound source. These may include TA (Time Above - expressed in minutes for which aircraft-related noise exceeds a specific A-weighted sound level, or dBA) and  $L_{max}$  (A-Weighted Maximum Sound Level). Several states utilize other related metrics such as Community Noise Equivalent Level (CNEL) as well as specific Level exceedence percentiles ( $L_n$ ).

## 3.3.2 Noise Prediction Programs

Currently, there are only three FAA approved computer based noise models for airport / aircraft planning. For conducting analysis of fixed wing aircraft operations the two accepted programs include the Integrated Noise Model developed by the FAA, and NOISEMAP developed by the U.S. Air Force. Historically, NOISEMAP was applied to

military type airfield facilities primarily because their data base involved military aircraft while the INM was the civilian counterpart to be used at civilian airports involving air carrier and general aviation operations. Today, the picture is now changing due to the expansion of existing aircraft types in the data bases, as well as the initiation of joint land use studies (JLUS) involving military and civilian air facilities. Consequently, the distinctions and applications are becoming less clear. FAA will now accept airport planning studies that have utilized NOISEMAP for the development of noise contours, in addition to the INM. They would still prefer to have NOISEMAP be applied only to military and JLUS type airports rather than civilian facilities, primarily due to the extensive NOISEFILE which includes all military type aircrafts.

### 3.3.2.1 Integrated Noise Model (INM)

Historically, the INM has been the standard prediction analysis tool used by the FAA to compare all computer based airport noise models for airport planning and impact analysis. In January, 1978, Version 1 of the INM was initially released. Since that date, improvements have been constantly made in terms of expanded data bases, additional input options, as well as user interface, among other features. Today, the FAA is using INM Version 3.10. Version 3.10 refers to the third version of the source code, and the 10th data base. A major transition was from a mainframe to an optional personal computer based version. This model has been used to support, FAR Part 150 Airport Noise and Land Use Compatibility studies along with airport master plans and environmental impact assessments and statements. A general description of INM 3.10 can be found in Appendix C.

Currently, there are over 200 airports that have used the INM for determining baseline as well as five year noise contour projections in order to produce Noise Exposure Maps (NEM) for the FAA to review and approve. A minimum of three equal energy noise contours expressed in DNL must be plotted for an airport and its environs as part of the FAR Part 150 process [3.7, 3.8]. They should include the 65, 70, and 75 DNL, however, the INM is capable of producing contours from 55 to 85. The actual land area (per square mile) of each contour is also plotted. Four specific metrics can be calculated by this model including DNL, LEQ, Noise Exposure Forecast (NEF) and TA. This present data base contains 101 different aircraft and 67 sets of noise tables (Appendix C). Grid point analysis can also be performed in order to determine one decibel intervals to refine a geographical distribution of the noise. At the current time, FAA does not provide any population and land use data bases or software interface to assist in the geographical and demographic distribution of data.

### 3.3.2.2 NOISEMAP

The first fully computerized procedures for generating cumulative noise contours around airbases was begun by the U.S. Air Force in 1971. Like its counterparts in the FAA, the military has expressed concern that noise associated with airbase flight and

ground runup activity could result in incompatible land use impacts, community annoyance and the threat of legal action, potentially impairing or restricting navigable airspace and airport capacity.

Shortly after NOISEMAP became operational, the Department of Defense in 1973 established the Air Installation Compatibility Use Zone (AICUZ) program. A major reason for establishing AICUZ for the military was similar to the PART 150 FAA program; to protect the operational capability of air installations, minimize encroachment and any potential incompatible land uses. A primary difference between INM and NOISEMAP is the addition of Accident Potential Zones. The AICUZ considers noise contour zones, and accident potential zones, since aviation training is an important component of military installations. Airspace modeling and a computerized simulation of training operations including noise and accident potential is a major goal of any military related AICUZ plan.

The present version of NOISEMAP, Noise Exposure Model Version 6.0, is pc based, making it similar to INM Version 3.10. It operates on any MS-DOS 80286 or greater having a math co-processor and at least one megabyte of memory. NOISEFILE is an ASCII file for both military and civilian aircraft including flyover and runup related noise. This NOISEFILE aircraft data base is larger than the INM since it contains over 200 different aircraft with a slightly larger percentage being military than civilian. In contrast, the INM provides a pre-approved list of aircraft substitutions by airplane category which are equivalent to specific aircraft models and series.

The Air Force is also striving to take advantage of emerging multi-media technologies including optical disk storage coupled with digitized geographic and demographic data bases. At this point in time, it appears the FAA has not placed as much emphasis in this area as the Air Force.

#### 3.3.2.3. Helicopter Noise Model (HNM)

Rotary wing aircraft has been modeled for determining the total impact of helicopter noise at and around proposed heliport sites. The HNM was developed for the FAA and issued as Version 1 in February, 1988 [3.3]. This model is a companion to the INM and provides similar noise metrics as outputs, including DNL. This current version has not been updated by the FAA, due to other priorities.

The HNM was developed to be used in conjunction with any FAA funded heliport planning studies, as part of the FAR Part 150 program. To date, there have been approximately 20 studies initiated in the vertical flight area which includes helicopter and/or tilt rotor aircraft. There appear to be current operational problems in the computer program and the FAA at the present time is not recommending that the HNM be used, until changes are made and version 2 is released. Such a new version is expected to be available by 1994.

### 3.4 CONCLUSION

Computer based noise modeling for fixed wing military and civilian aircraft including both flyover and run-up activity has evolved substantially over time. Both the FAA and the Department of Defense (primarily the U.S. Air Force) have initiated major programs to support airbase and airport planning and impact assessment. The Air Force computer noise modeling initiative is now 22 years old, while the FAA activity began seven years later in 1978.

Today, both of these programs can plot equal energy noise contours with an increasing degree of accuracy for various aspects of aircraft activity, in a two dimensional field. Due to the interest of the Federal government and FICON, a common metric, the DNL has been selected for describing the overall noise impact in the vicinity of airports for compatibility planning purposes. Through expanded data bases, new source codes and other related refinements portraying aircraft noise in a free field environment are becoming increasingly accurate. These models provide good computer fidelity from an acoustical standpoint. However, spatially, they are prepared only from a two dimensional point of reference. Currently, graphics interface, multi-media applications and the full utilization of other relational data bases have not been fully explored at this time.





**NASA/GT**

AIRCRAFT NOISE ROUTE IMPACT ANALYSIS



# **SECTION 4**

**LAND USE  
DATA BASES**



## 4.1 INTRODUCTION

### 4.1.1 Purpose

The purpose of this section is to identify and evaluate the present land use profiles for both existing and projected land uses for the United States and to determine their compatibility in terms of classification, scale, coverage, accuracy, availability, and computer applicability. These profiles include federal, state, and local governmental entities.

### 4.1.2 Background

The regulation of land is the responsibility of the state or local government. Federal government only regulates the use of federally owned land. Existing laws and regulations for the use of land vary among governments. The documentation of these laws is beyond the scope of this study. This section identifies and evaluates the current land use profiles for both existing and projected land use inventories within the United States. Efforts are made to determine their compatibility in terms of classification, scale, coverage, accuracy, availability and computer applicability in order to maximize their utility for airport planning.

This research study has been successful in identifying a wide variety of data sets. A large number of land use profiles were obtained from various governmental units, particularly federal agencies. Attempts were also made to identify the data bases at the state and local level; however, only a small number of these were actually received. Even though there were 15 data bases considered relevant to this section all originating from five federal agencies, there may well be others in existence.

### 4.1.3 Interrelationship

Land use data are essential in determining the planning of airport development and the routing of aircraft through space. The control of land is a critical factor to this study; consequently, there are significant interrelationships between this section and the remaining sections. Levels of relationship between this and other sections of this report are shown in Table 4.1.

Table 4.1 Interrelationship of land use data bases and other sections.

<u>Section</u>	<u>Name</u>	<u>Level of Relationship</u>
2	Geographic information systems	R1
3	Sound metrics and descriptors	R1
5	Governmental regulatory data base	R2

6	Airspace operational control measures	R1
7	Federal regulation and advisory circulars pertaining to route analysis	R2
8	Census, demographics, and real estate based analysis	R1
9	Environmental attributes	R1

R1 - Major relationship  
R2 - Moderate relationship  
R3 - Minor relationship  
R4 - No relationship

#### 4.1.4 Relevance

The use and regulation of land as three-dimensional space is a major factor in the planning of airports and aircraft routing. Land use data bases could serve as a fundamental tool in achieving a comprehensive national airport planning compatibility system. The documentation and survey of existing land uses will contribute to the determination and location of incompatible uses with aircraft related activity (i.e. run-up, takeoff, landing, and flyover aspects of flight operations). Consequently, identifying and evaluating the present land use profiles for existing and projected land use in the United States and determining their compatibility in terms of classification, scale, accuracy, coverage, availability and computer applicability are essential elements of this project.

## 4.2 METHODOLOGY

### 4.2.1 General

A fundamental planning approach in locating airports and their route structure is to identify and evaluate the existing and projected land uses. The following federal agencies all maintain data bases of existing land uses, which are generally available for the United States in a digital format:

1. Defense Mapping Agency (DMA)
2. U.S. Geological Survey (USGS)
3. U.S. Department of Agriculture - Soil Conservation Service (SCS)
4. Earth Science Information Center (ESIC)
5. National Cartographic Information Center (NCIC)

Each of these federal agencies provided certain data bases for information covered in this section of the study report. Due to the varied missions of these agencies, they offer nationwide data that may be helpful in characterizing land use in a variety of ways.

It is very evident at this point in time that there is not a singular data base that characterizes land use on a comprehensive basis nationwide.

#### 4.2.2 Specific

The following data bases were collected through the use of a letter survey and literature search. Each data base was obtained and evaluated to assess its potential applicability for an impact assessment of any existing or planned air route system.

1. Digital Elevation Models (DEM's)
2. Digital Terrain Elevation Data Level 1 (DTED 1)
3. World Mean Elevation Data (WMED)
4. Land Use and Land Cover (LULC) and Associated Maps Digital Data
5. Digital Planimetric Data
6. Digital Feature Analysis Data (DFAD)
7. Interim Terrain Data (ITD)
8. Tactical Terrain Data (TTD)
9. Geographic Names Information Data Base
10. Probabilistic Vertical Obstruction Data (PVOD)
11. Automated Air Facilities Information File (AAFIF)
12. Digital Aeronautical Flight Information File (DAFIF)
13. Electronic Chart Updating Manual (ECHUM)
14. Multispectral Imagery
15. Digital Soils Data

### 4.3 FINDINGS

#### 4.3.1 Data Bases at the National Level

Existing data bases at the national level are primarily produced by the Defense Mapping Agency (DMA), U.S. Geological Survey (USGS), and US Department of Agriculture - Soil Conservation Service. The data bases that are produced by DMA and USGS are also distributed through a series of federal information centers, including the Earth Science Information Center (ESIC), and the National Cartographic Information Center (NCIC). Appendices D-G provide summary descriptions of selected data bases, including figures.

The characteristics of these data bases range significantly; however, some basic generalizations can be drawn regarding their content. Four general categories of data included in these data bases address elevation, land use, soil, and ancillary data. These relevant data bases, identified as being applicable to routing, are described below.

##### 4.3.1.1 Data bases that provide information on elevation

The knowledge of elevation is vital in determining the location of airports and routing aircraft. There are three data bases that provide information on elevation (Appendix D). They include Digital Elevation Models (DEM's), Digital Terrain Elevation Data Level 1 (DTED1), and World Mean Elevation Data (WMED).

These data bases may be used in air routing to generate graphical displays of the slope, direction of slope, and terrain profiles between designated points. They also can be used as the basic medium resolution elevation data source to obtain land form, slope, elevation, and terrain roughness in a digital format. The information on land form, elevation, slope, and direction of slope can prove vital in locating sites for airports as well as for simulation.

#### 4.3.1.2 Data bases that provide information on land use

There are five data bases that provide information on land use. These include Land Use and Land Cover (LULC) and Associated Maps Digital Data, Digital Planimetric Data, Digital Feature Analysis Data (DFAD), Interim Terrain data (ITD), and Tactical Terrain Data (TTD) (Appendix E).

These data bases will be useful in locating all areas with similar characteristics for area analysis, that is, in locating suitable sites for airports. The data can be used in various combinations to conform to the requirements of a specific project. It is possible, for example, to use only the file containing "Airports", omitting the files for the other categories in transportation.

#### 4.3.1.3 Data bases that provide information on soils

The U.S. Department of Agriculture Soil Conservation Service has established three soil geographic data bases representing different intensities (based upon the level of detail) of soil mapping. Common to each soil geographic (spatial) data base is the linkage to a soil interpretations (attribute) record data base which gives the proportionate extent of the component soils and their properties for each map unit. With these computerized data bases, users can store, retrieve, analyze, and display soil data in a highly efficient manner, as well as integrate the data with other spatially referenced source and demographic data in a GIS environment. Soil classification and the suitability for land development becomes an important parameter in determining future land use patterns and their degree of compatibility.

The three data bases include the Soil Survey Geographic Data Base (SSURGO), the State Soil Geographic Data Base (STATSGO), and the National Soil Geographic Data Base (NATSGO) (Appendix F).

#### 4.3.1.4 Ancillary data bases

Ancillary data bases contain more specialized information that could be applicable depending upon the specific task. These data bases include:

- A. Geographic Names Information Data base (GNID)
- B. Probabilistic Vertical Obstruction Data (PVOD)
- C. Automated Air Facilities Information File (AAFIF)
- D. Digital Aeronautical Flight Information File (DAFIF)
- E. Electronic Chart Updating Manual (ECHUM)
- F. Multispectral Imagery (MSI)

Details of the six data bases can be found in Appendix G. This appendix provides a description and application for each data base.

#### 4.3.2 Land use data bases at the state and local level

##### 4.3.2.1 Land use data bases at state level:

There is considerable activity in the development of land use data base information at both the state and local levels of government. Various organizations have been formed at the state and local level to look at spatial data and to create an environment for exchange and sharing of the spatial data between the related organizations. Several states, including Georgia, Florida, Alabama, California, New Hampshire and North Carolina, have taken the lead in this area. There is an increasing trend to develop comprehensive statewide data bases to address multiple user interest including reapportionment, tax digests, reappraisal, emergency preparedness, environmental impact, and comprehensive planning.

In order to explain this phenomena at the state level in more detail, the "Creation of Georgia Land use Classification System" [4.1] is described below.

The Georgia Planning Act of 1989 directed the Department of Community Affairs (DCA) to "coordinate and participate in compiling a Georgia data base and network to serve as a comprehensive source of planning information available to local governments and state agencies". DCA has established the Office of Coordinated Planning which is responsible for implementing the Planning Act in terms of a Statewide GIS. Through the local government comprehensive planning process identified in the Planning Act, a region-wide and statewide GIS will be developed by DCA. As local comprehensive plans are certified by DCA, each Regional Development Commission (RDC) will compile land use information (both existing and future) and community facilities information from each local plan. This information will be digitized and incorporated into each RDC's Standard Industrial Classification (SIC) system. The intent is to incrementally "build" a region-wide and statewide land use and community facilities GIS and data base which will contain such planning information as land use, the location of streets, schools, hospitals, airports, fire stations, among other uses.

A GIS containing these and other items of planning-related data will serve three basic purposes of the Georgia Planning Act of 1989:

1. Enabling RDCs to better evaluate the consistency of a local government plan with its neighboring local government plans;
2. Allowing RDCs and DCA to systematically acquire and maintain land use and community facilities data for each region of the state;
3. Assisting RDCs in the preparation of regional plans as local comprehensive planning is completed in 1994-95.

Many other states are beginning to see the benefits of such a digital based mapping initiative.

As a first step to facilitate the development of the statewide GIS, local governments in Georgia are being asked to use a standardized classification system when conducting inventories of land use and economic information within their jurisdictions.

The use of the standardized land use classification system by local governments would:

1. Provide a basis for better land use and economic analyses within and among local governments
2. Enhance local land records management (property ownership, land use taxation, appraisals, etc.)
3. Facilitate the establishment of the statewide GIS.

#### 4.3.2.2 Land use data bases at local level:

To explain the coordinating effort at the local level, the following regional program for metropolitan Washington, D.C. is described:

In 1984, five organizations - the Washington Suburban Sanitary Commission (WSSC), Prince George's County, Montgomery County, and the two county branches of the Maryland-National Capital Park and Planning Commission (MNCPPC) explored the idea of developing a GIS for the bi-county area. Led by WSSC, the consortium also included the Maryland Department of Assessments and Taxation as a non-voting participant. Initially calling itself the Interagency Committee (now called the GeoMAP committee), the group selected a vendor in 1986 to study the technical, institutional, and economic feasibility of a multi-agency GIS. The pilot project area was identified as a total area of 6.9 square miles [4.2].

It is very evident that municipal and regional governmental agencies are beginning to develop rather ambitious initiatives in this area like the states.



#### 4.3.3 Land use data base from individual GIS vendors

There are several land use data bases developed by individual GIS vendors. These data bases do not cover the entire United States. However, they could serve as an important resource at the local level by serving as a supplement to existing government information. Privately developed data bases may have certain limitations as well. Specifically, limiting factors may be:

1. Data bases which are developed by using a certain type of coordinate system may be different from the coordinate system established for the governmental entity. This may cause an incompatibility problem of which reduces the usefulness of the data base
2. The data bases may not have the ability to read data from various sources which form an important element in airspace planning
3. The claims made by these vendors about the capability of importing data from a different data base into their data base may be vague or inaccurately stated.

Different sets of data are available from a variety of GIS vendors. For details concerning both data bases and hardware refer to Section 2, Geographic Information System.

#### 4.3.4 Data Standardization and Coordination

There are certain issues significant to our study concerning standardizing land use data bases for compatibility purposes. A secondary concern is coordination among the various agencies to ensure proper coordinating and data compatibility.

##### 4.3.4.1 Spatial Data Transfer Standard (SDTS)

The USGS has taken the lead in creating a data standard that will facilitate the exchange of digital spatial information between dissimilar computer systems. The committee is seeking approval for the SDTS as a Federal Information Processing Standard (FIPS) [4.3].

The objectives of creating the standard are:

1. To provide a mechanism to transfer digital spatial data between dissimilar computer systems while preserving data meaning and minimizing the need for descriptive information about the data;
2. To provide a set of "standards" objects and relationships representing real-world spatial entities that can be transferred among and interpreted by dissimilar systems;
3. To provide a model that transfers objects and relationships into SDTS while

- preserving meaning;
4. To ensure that any implementation of SDTS has the following characteristics;
    - a. The ability to transfer raster, vector, grid, attributes and other ancillary data.
    - b. The ability to be implemented on any media.
    - c. The ability to encompass new spatial data.
    - d. The ability to maintain descriptions of data types, formats, and structures in such a way that information can be processed by a user's native system; and
    - e. The ability to base data and media formats on existing FIPS, ANSI, ISO, and other accepted standards.

#### 4.3.4.2 Federal Geographic Data Committee (FGDC)

In response to a request from the Office of Management and Budget (OMB) regarding coordination of federal spatial data use, the Federal Inter-agency Coordinating Committee on Digital Cartography (FICCDC) has been renamed as the Federal Geographic Data Committee. (FGDC) in order to reflect the broader coordination responsibility.

The FGDC supports surveying and mapping activities, aids GIS uses, and assists land managers, technical support organizations, and other users in meeting their program objectives through:

1. Promoting the development, maintenance, and management of distributed data base systems that are national in scope of surveying, mapping, and related spatial data;
2. Encouraging the development and implementation of standards, exchange formats, specifications, procedures, and guidelines;
3. Promoting technology development, transfer and exchange;
4. Promoting interaction with other existing coordinating activities that have interest in the generation, collection, use and transfer of spatial data.

This newly renamed committee has established a series of goals. The primary goals are to increase the Nation's ability to compete more effectively in the world marketplace, resolve complex issues and improve the efficiency and effectiveness of federal programs.

Three major objectives have been established by the committee to accomplish these goals. They are:

1. Promote the development of a National Digital Spatial Data infrastructure;

2. Reduce duplication and waste; promote sharing of digital spatial data;
3. Promote wise use of spatial data technologies.

Currently the FGDC is involved with a series of activities that have applicability to land use data bases. These activities include: developing a National Geographic Data System (NGDS) (a system of independently held and maintained Federal Digital Spatial data bases, linked by standards and criteria); updating the FICDC technical report "A Process for Evaluating GIS"; and continuing to inventory and revise the "Summary of GIS Use in the Federal Government".

#### 4.4 CONCLUSIONS

Land use information is available in abundance, and at all levels of government. The type of land use information covers a broad range of categories from physiographic natural features to social, cultural, and population based. Federal coverage of general geographical characteristics appears to be more advanced than state and local initiatives. Digitized land use base maps reflecting existing and proposed comprehensive local, regional, and statewide master plans are in the process of being developed, but are far from being complete. Furthermore, they are not being standardized, although certain standards setting groups are preparing guidelines. Secondly, land use related criteria for airport noise compatibility have not been fully developed, although there are positive initiatives for federally related projects [3.1, 3.8].



**NASA/GT**

AIRCRAFT NOISE ROUTE IMPACT ANALYSIS



# **SECTION 5**

**GOVERNMENT  
REGULATORY  
DATA BASE**



## 5.1 INTRODUCTION

### 5.1.1 Purpose

The major objectives of this section are: 1) to inventory and to analyze the various current regulations that address land use impacts (from an environmental noise perspective) at the local/state governmental level, and 2) to determine the characteristics of such information systems, including their computer applicability.

### 5.1.2 Background

Historically, local governments were the first political entities to initiate any type of noise legislation in the United States [5.1]. During the early stage of regulatory history, these laws contained only general descriptive language. At that time, noise was not quantified (e.g., noise was defined as being unreasonably loud, disturbing, or unnecessary) [5.1].

Prior to 1930, there was limited interest in noise regulations. With the publication of City Noise in 1930 by the New York City Department of Public Health, noise sources were measured for the first time. This work was conducted in conjunction with the Bell Laboratories [5.1]. Before the end of the decade, vehicle noise emission based laws were being enacted with Memphis, Tennessee becoming the first city. The first national model noise ordinance was written in 1948 by the National Institute of Municipal Law Enforcement Officials (NIMLO) [5.1]. Noise related land use controls were initially adopted in 1955 when the city of Chicago amended their zoning ordinance incorporating performance standards for noise [5.1].

A summary of the municipal noise regulations and programs established over the past seven decades is presented in Table 5.1. During the 1930s, there were only 20 municipalities with regulations in place. This number remained constant for the next 40 years. Even as recently as the 1970s, there were only 59 municipalities with noise laws. It was the establishment of the U.S. Environmental Protection Agency (EPA) and the Office of Noise Abatement Control that provided the primary impetus for the growth of both state and local legislation [5.1]. During the 1980s, the number of municipalities having noise legislation in place grew from 59 to 1,284. In more recent years, there has been a general leveling off in the number of new ordinances. By the end of 1991, that number had grown modestly to 1,534, (Table 5.1).

Table 5.1 Municipal noise regulations.

PERIOD	MUNICIPAL NOISE REGULATIONS
1930	20
1940	25
1950	35
1960	55
1970	59
1980	1,284
1991	1,534

### 5.1.3 Interrelationship

Section 5 is related to the other project sections in varying degrees, as illustrated by the matrix of sectional relationships (Table 5.2). This section is most strongly related to Section 3 since these regulations usually contain acoustical provisions that incorporate sound metrics (e.g. sound level expressed in dBA). Section 3 is concerned with noise terminology, sound metrics, descriptors and noise prediction models. These noise related terminologies are relevant to noise abatement procedures that are the subject of Section 6. Certain operational controls described in Section 6 can be related to certain noise ordinance provisions (i.e., run-up noise). To a lesser extent, Section 5 is related to Sections 8 and 9. No minor relationships (i.e., R3) between Governmental Regulatory Data Bases and the other sections of this report were identified.

Table 5.2 Interrelationship between governmental regulatory data bases and other sections.

<u>Section</u>	<u>Name</u>	<u>Level of Relationship</u>
2	Geographic information systems	R1
3	Sound metrics and descriptors	R1
4	Land use data bases	R2
6	Airspace Operational Control Measures	R1
7	Federal Regulatory Circulars - Route Analysis	R1
8	Census, Demographics, Real Estate Based Analysis	R2
9	Environmental Attributes	R2



R1 - Major relationship  
R2 - Moderate relationship

R3 - Minor relationship  
R4 - No relationship

#### 5.1.4. Relevance

Section 5 is relevant to the major objectives of this research project and can assist in the development of a Geographic Information System (GIS) relational data base that incorporates noise. The noise criteria and standards pertaining to land use (i.e., space use) can be evaluated in three dimensions for space compatibility planning since land use regulations relating to noise define property in three dimensional terms. It is important to recognize that only certain local noise controls are applicable to aviation due to federal pre-emption and interstate commerce provisions associated with the FAA Act, and upheld by the courts.

## 5.2. METHODOLOGY

### 5.2.1 General

In an effort to inventory and analyze the various present data bases that regulate land use impacts at the local level, selected municipalities were mailed questionnaires. Additional regulatory information was obtained by a literature search.

### 5.2.2 Specific

A data base spreadsheet was developed to enter both existing and new regulatory information concerning local governments in the United States. The first environmental survey was initiated to determine the status of regulations for all U.S. cities. Surveys were sent to over 4,800 municipalities. The 928 municipalities offering responses about environmental noise regulations were sent a follow up letter and questionnaire requesting copies of their noise regulations. Appendix H contains the questionnaire and cover letter used for the survey along with the summary tables of municipal laws by noise provision. Currently, 430 cities (46%) have responded positively by submitting new information for the data base. All ordinances received have been filed by state then alphabetized by city and compiled into the data base. These responses have been merged with the local noise regulations data base described in Municipal Noise Legislation [5.2]; the result is an expanded data base currently containing 1,534 municipalities.

## 5.3 FINDINGS

### 5.3.1 Noise Regulatory Provisions

Based on the original 1980 municipal survey, there were 1,284 laws in place;

currently there are 1,534 enacted noise ordinances. This represents a modest growth of 250 additional ordinances over 21 years in the United States. A summary of these regulations that pertain to some aspect of noise and land use is found in Appendix H. For the purposes of this survey, these noise ordinances contain ten provisions including:

1. Nuisance
2. Zoning
3. Vehicles
4. Recreation Vehicles
5. Railroad
6. Aircraft
7. Construction
8. Building Code
9. Animals
10. Entertainment

Each of these ten provisions has either a Yes or No response. An affirmative response indicates the provision contains an acoustical level using some quantitative noise descriptor, while a negative response indicates there is no acoustical value specified and the legal language used is subjective in nature. Non-acoustical laws are based upon the exercise of police power and general nuisance. Table 5.3 depicts the total number of noise ordinance provisions adopted or enacted during the last three decades. It is clear that the most common noise ordinance provisions at the local level apply to nuisance, zoning, and vehicle related activities. In contrast, the least frequently mentioned regulations, numbering less than 200 responses, pertain to railroad, aircraft, and building codes. A discussion of each of the ten provisions is contained in the following subsection.

Table 5.3 Municipal noise regulations.

MUNICIPAL NOISE LAWS AND PROVISIONS		1971	1981	1991
		Total	Total	Total
Municipal Laws	Noise	59	1,284	1,534
Provisions:				
	Nuisance	50	982	1,331
	Zoning	23	698	926
	Vehicles	13	706	819
	Vehicles: Recreation	1	484	634
	Railroad	4	61	165
	Aircraft	5	85	196
	Construction	15	558	657
	Building Code	4	85	198
	Animals	0	77	358
	Entertainment	0	187	286

### 5.3.2 Specific Noise Provisions

#### 1. Nuisance

Nuisance laws are designed to cover all noise sources that may affect the legal use of the police power, specifically public safety, health, and general welfare (Figure 5.1). Laws of this kind do not define noise sources but rely on general language (i.e., "unnecessary loud") rather than any quantitative and measurable standards. Of the 1,534 municipalities with some kind of noise provisions, 905 or 59.0% of them have quantitative provisions and 426 (27.8%) have non-quantitative provisions of nuisance.

#### 2. Zoning/Land Use

Zoning provisions address the permitted use of land in terms of a district rather than parcel of land (Figure 5.2). Noise limits usually apply to district boundaries from an emitting source (i.e., noise generator). When the noise from an emitting source crosses the property boundary of the receiving source (e.g., a residence) this is considered the location for enforcing the ordinance provisions. Presently, there are 839 municipalities (54.7%) having quantitative provisions and 87 (5.7%) having non-quantitative provisions for zoning.

#### 3. Vehicles

Surface transportation noise is commonly regulated (Figure 5.3). These regulations apply to licensed vehicles operating on roadway rights-of-way. Most ordinances specify a maximum peak noise level (dBA), measured at a prescribed distance from the centerline of the path of the vehicle. The majority of vehicle laws use a distance of either 25 or 50 feet. These noise limits frequently depend upon vehicle speed (i.e., greater or less than 35 miles per hour). Currently, there are 667 (43.5%) municipalities which use acoustics provisions and 152 (9.9%) municipalities with non-acoustic provisions.

#### 4. Recreation Vehicles

Recreation vehicle provisions in most ordinances refer to off-road vehicles (e.g., motorized dirt bikes, all-terrain vehicles, snowmobiles) as summarized in Figure 5.4. Frequently noise restrictions are applied to where, when and what level of noise they may emit. Some regulations apply to their operational use on a public right-of-way while others apply directly to the manufacturer. Since the use of recreation vehicles is growing, there is an increasing interest in their regulation. Today, 584, or 38.1% of the municipalities establishing noise laws, have some acoustic provision.

#### 5. Railroad

Rail systems are commonly regulated as noted in Figure 5.5. Concern with the rail generated noise has paralleled the development of rapid transit systems in medium and high density areas. Usually the provisions are enforced on the basis of the

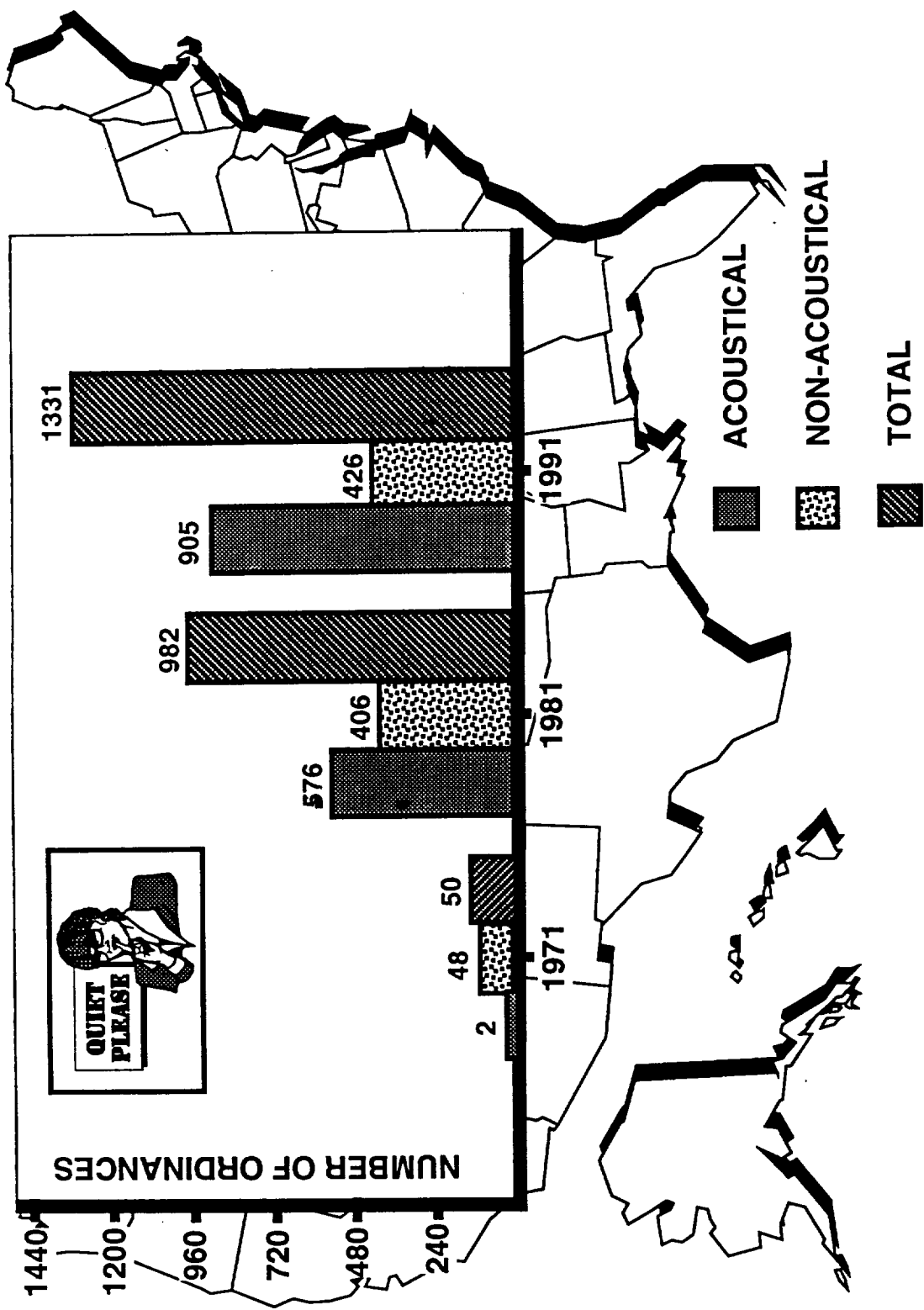

Figure 5.1 Noise ordinance provision: nuisance.

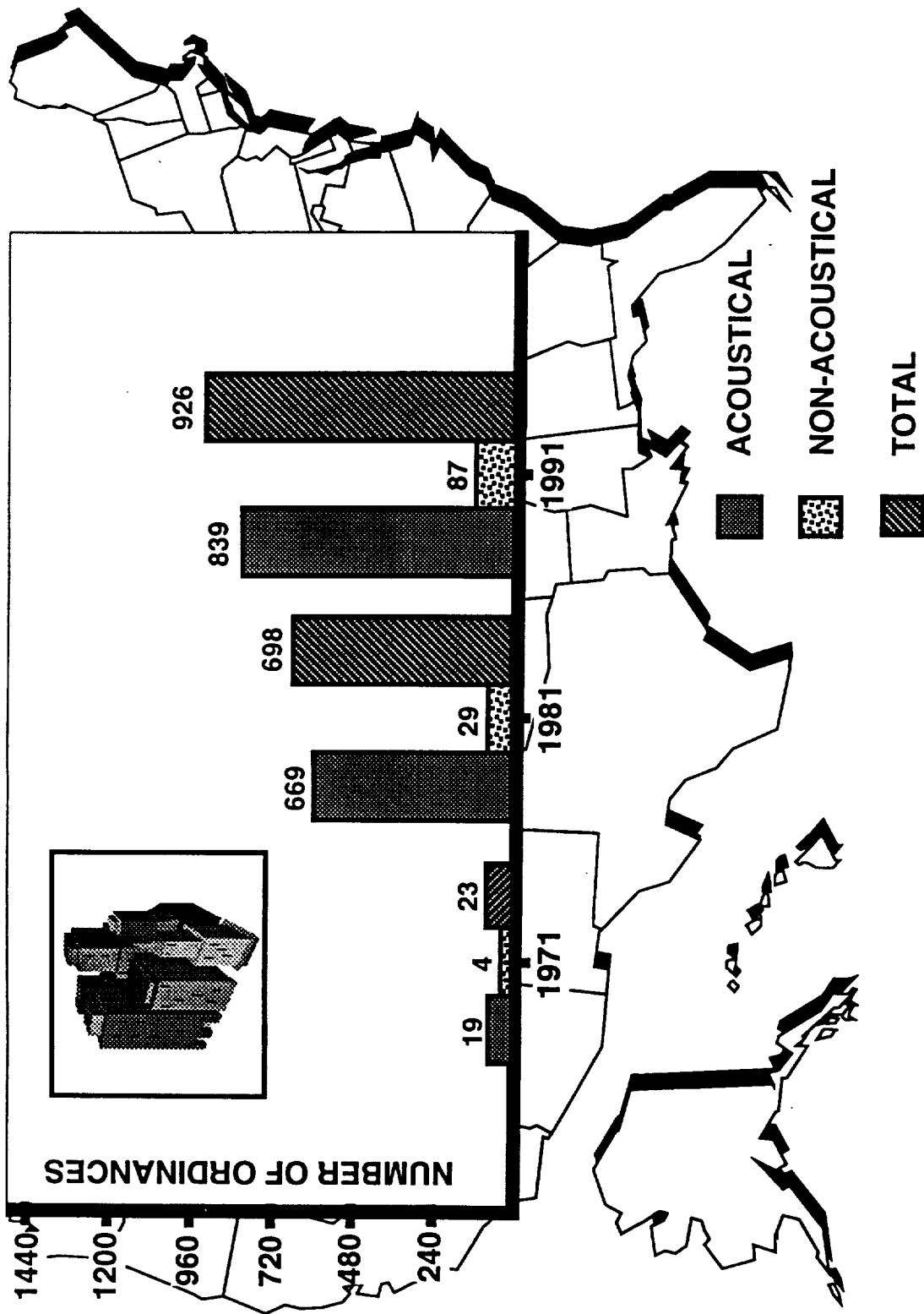

Figure 5.2 Noise ordinance provision: zoning / land use.

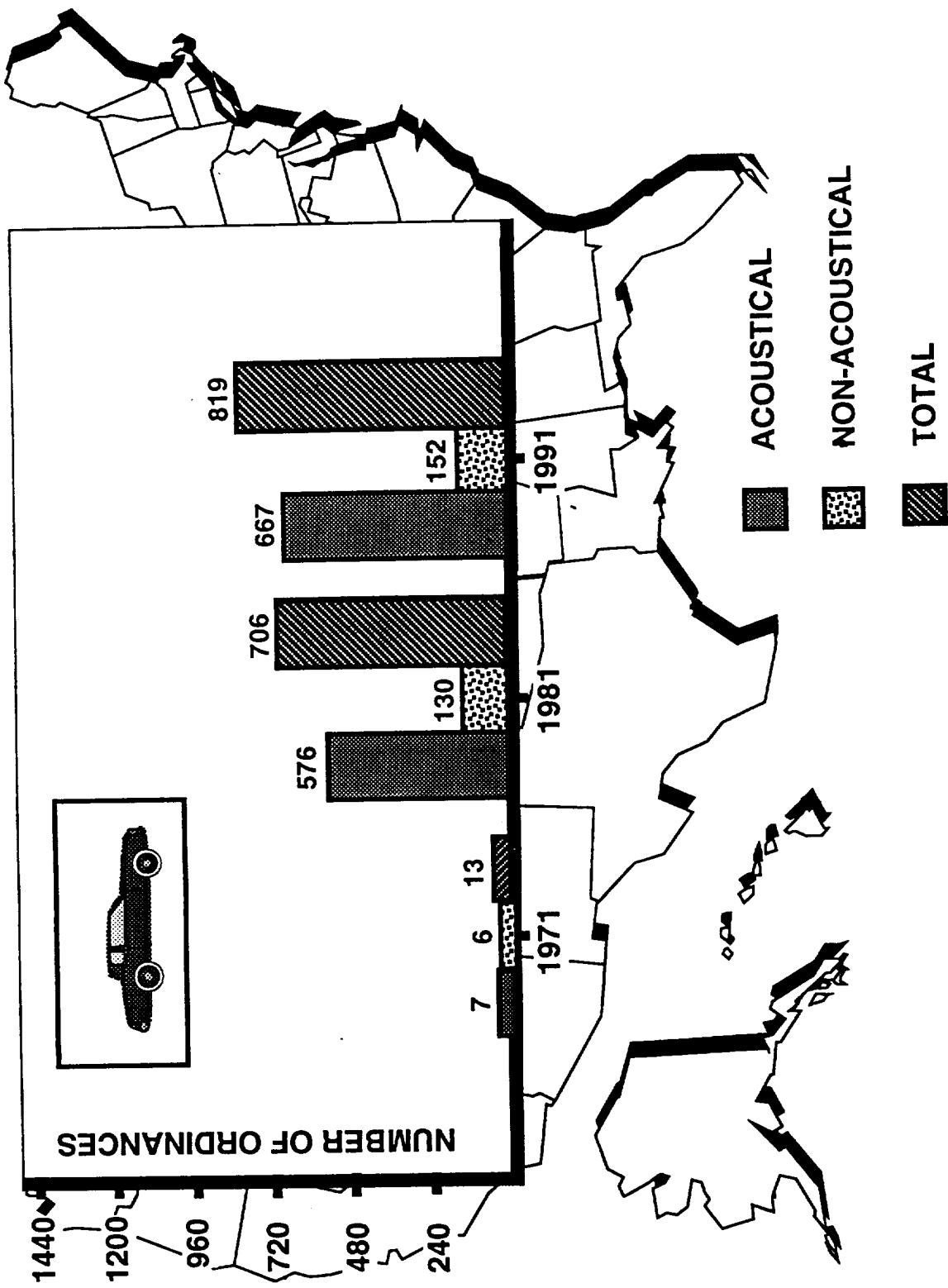

Figure 5.3 Noise ordinance provision: vehicles.

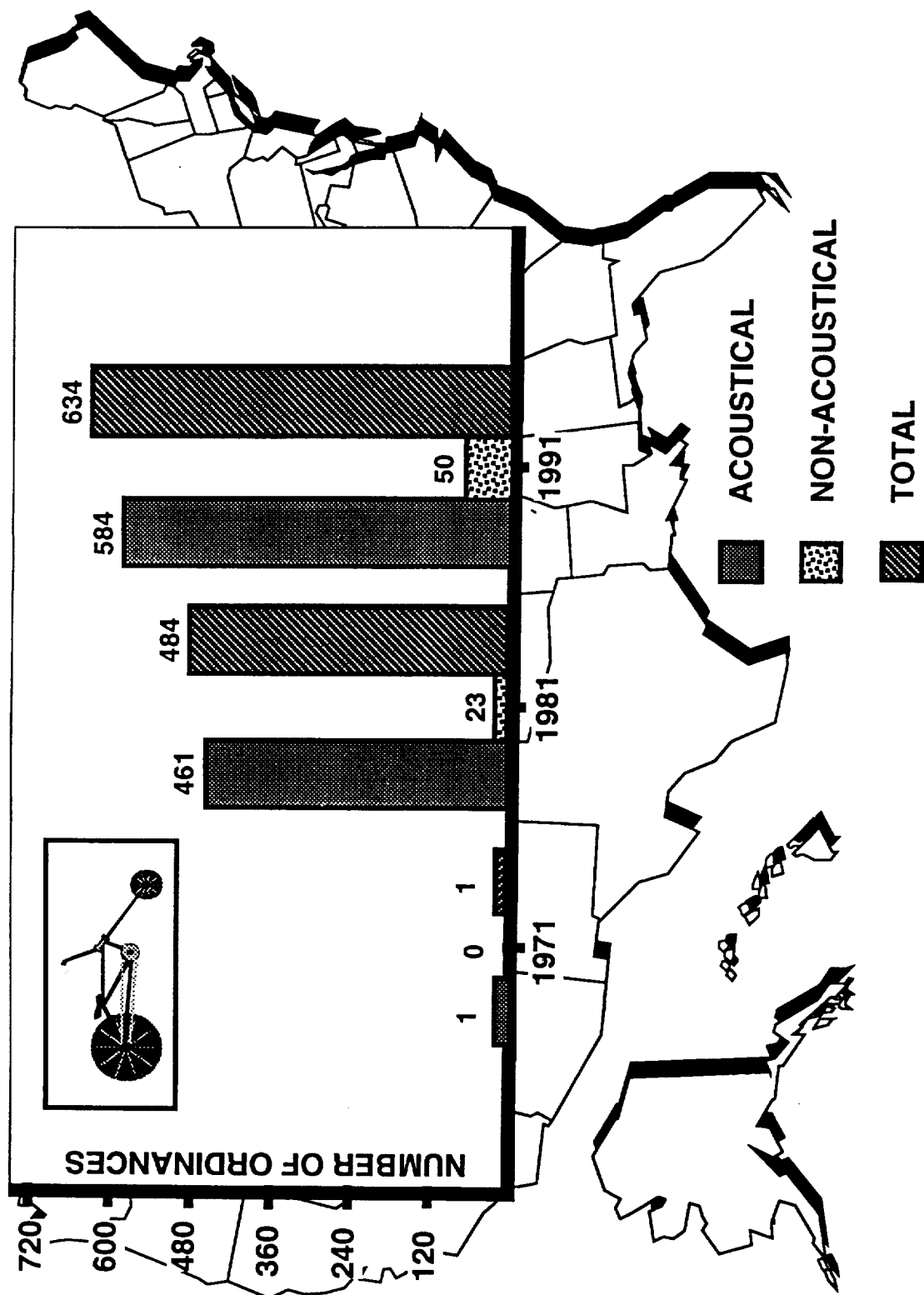

Figure 5.4 Noise ordinance provision: recreation vehicles.



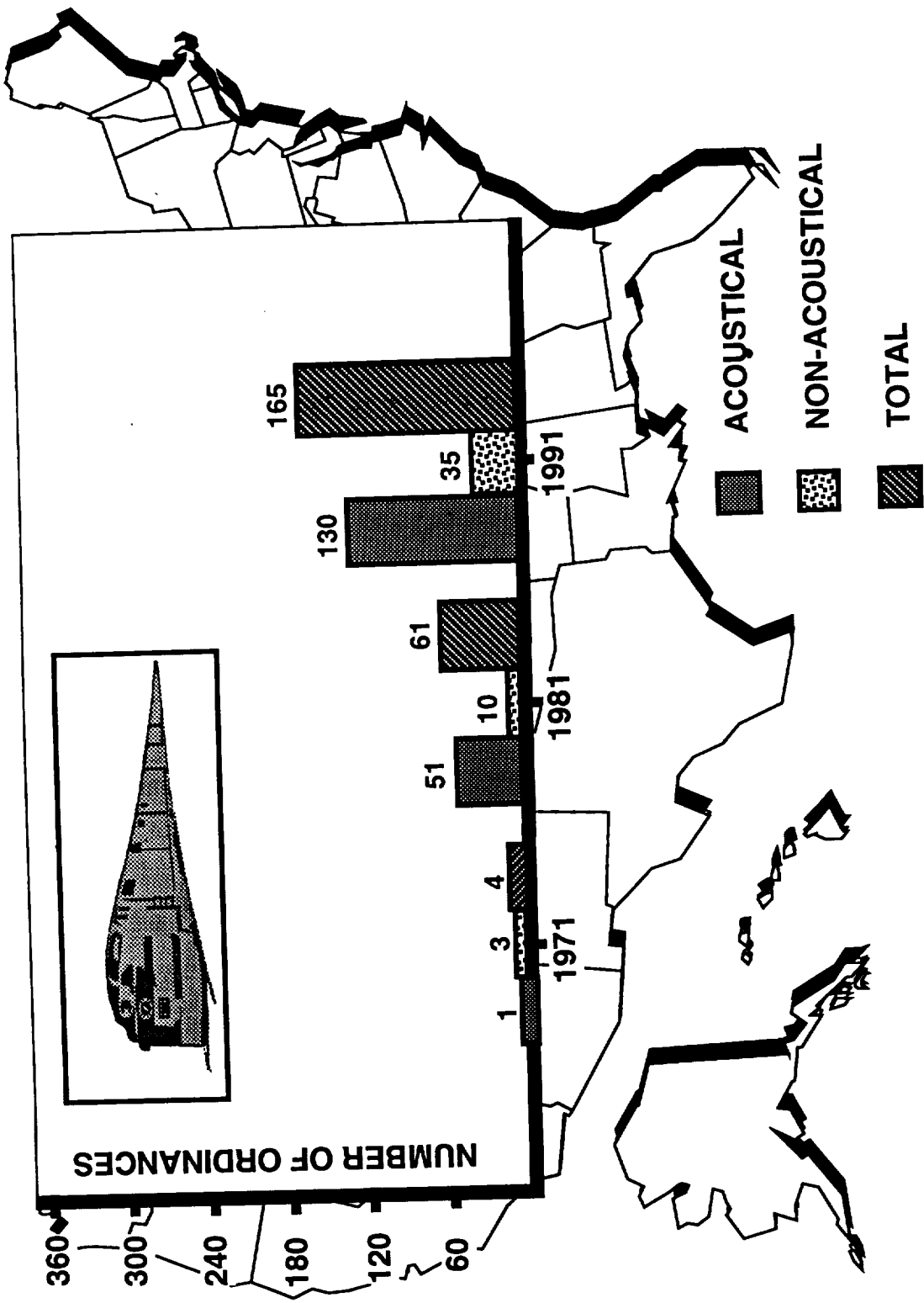

Figure 5.5 Noise ordinance provision: railroad.

primary source, rather than accessory noise (e.g., horn blowing). Mainline tracks and rail yard facilities are frequently regulated. Only 130 cities have quantitative provisions and another 35 cities have non-quantitative provisions for noise associated with railroad activity.

6. Aircraft

The noise generated by aircraft is regulated by the FAA since it involves navigable airspace associated with interstate commerce. Runup noise, which is part of maintenance and repair of aircraft is the most common form of local regulation. Some laws specify limits based on aircraft weight, type, or even manufacturer. Due to the total number of airports, some proprietors are installing noise monitoring systems. Many of these systems have been at least partially funded under the FAA Part 150 (Airport Noise and Land Use Planning) [3.7]. Today, just 159, or 10.4% of the municipalities have any type of quantitative aircraft noise emission requirements (Figure 5.6) while 37, or 2.4%, of the municipalities have non-quantitative requirements.

7. Construction

Construction activity is a significant source of noise due to the construction methods, hours of operation, and equipment used. Exemptions are usually given for emergency construction and repair (i.e., public streets, etc.). At this time, 536, or 34.9% of the municipalities, have quantitative provisions (Figure 5.7).

8. Building Code

Most cities do not have noise provisions within their building codes. There is a movement to incorporate noise standards previously adopted by building organizations. To date, there has been little effort to link energy conservation with sound control. Only 149, or 9.7% of the cities, have quantitative provisions and 49, or 3.2%, have non-quantitative provisions for building codes (Figure 5.8).

9. Animals

The domestic animal population is rapidly rising and so are complaints. Actual noise laws, however, are not found frequently. In most instances, the leash law is the basis for enforcement and noise measurements occur only on demand (resident) basis. Presently, 133, or 8.7% of the cities, have acoustic provisions and 125 have non-acoustics provisions for animal related noise. The findings are summarized in Figure 5.9.

10. Entertainment

Entertainment, particularly at outdoor public and commercial parks (e.g., theme parks) which permit electronically amplified music, is a recognized community noise problem. The number of ordinances addressing this subject is not large, but amplified musical entertainment can be a major source of impact to adjacent residential areas. In some cases, entertainment groups must perform within a

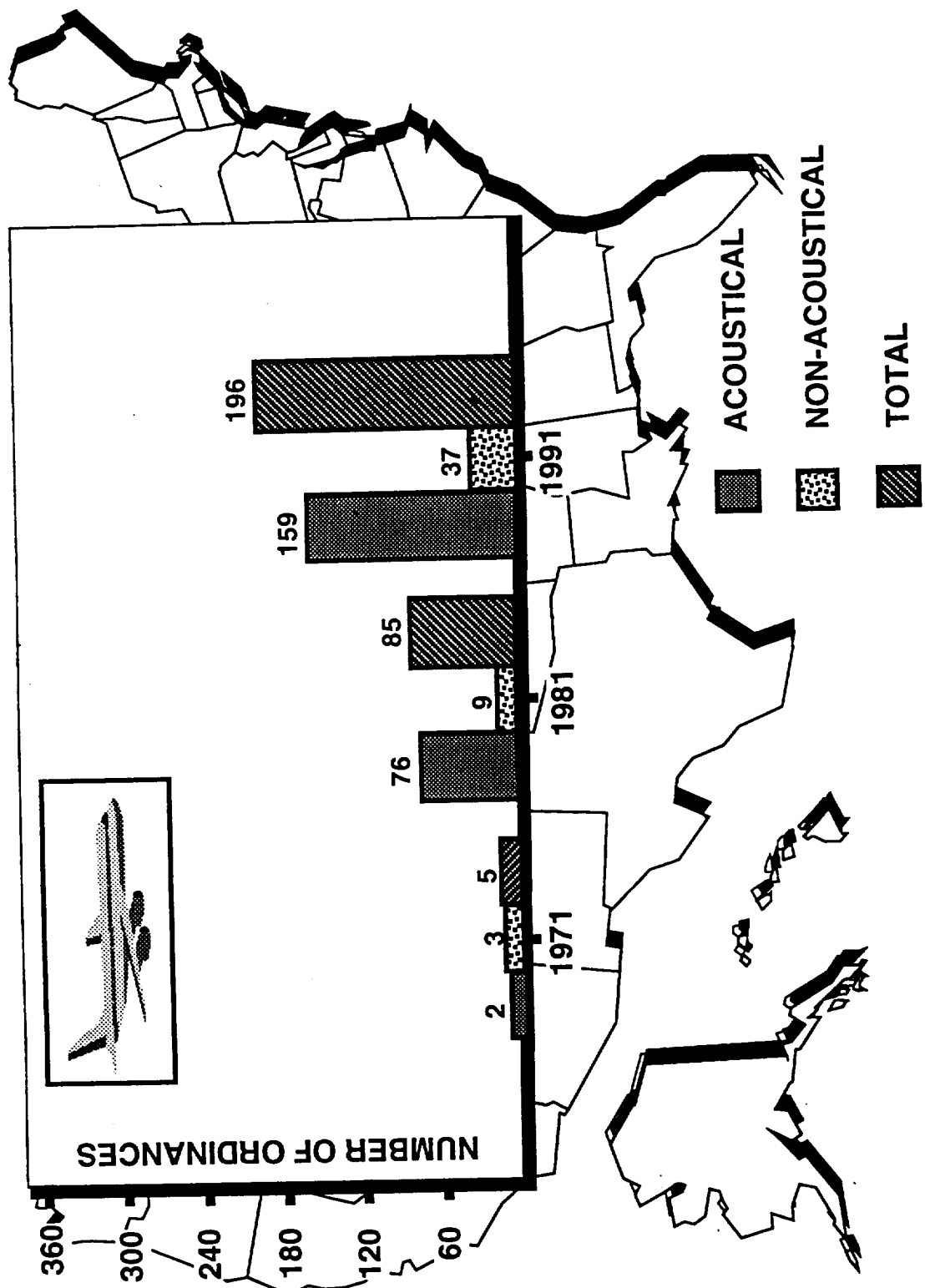

Figure 5.6 Noise ordinance provision: aircraft.

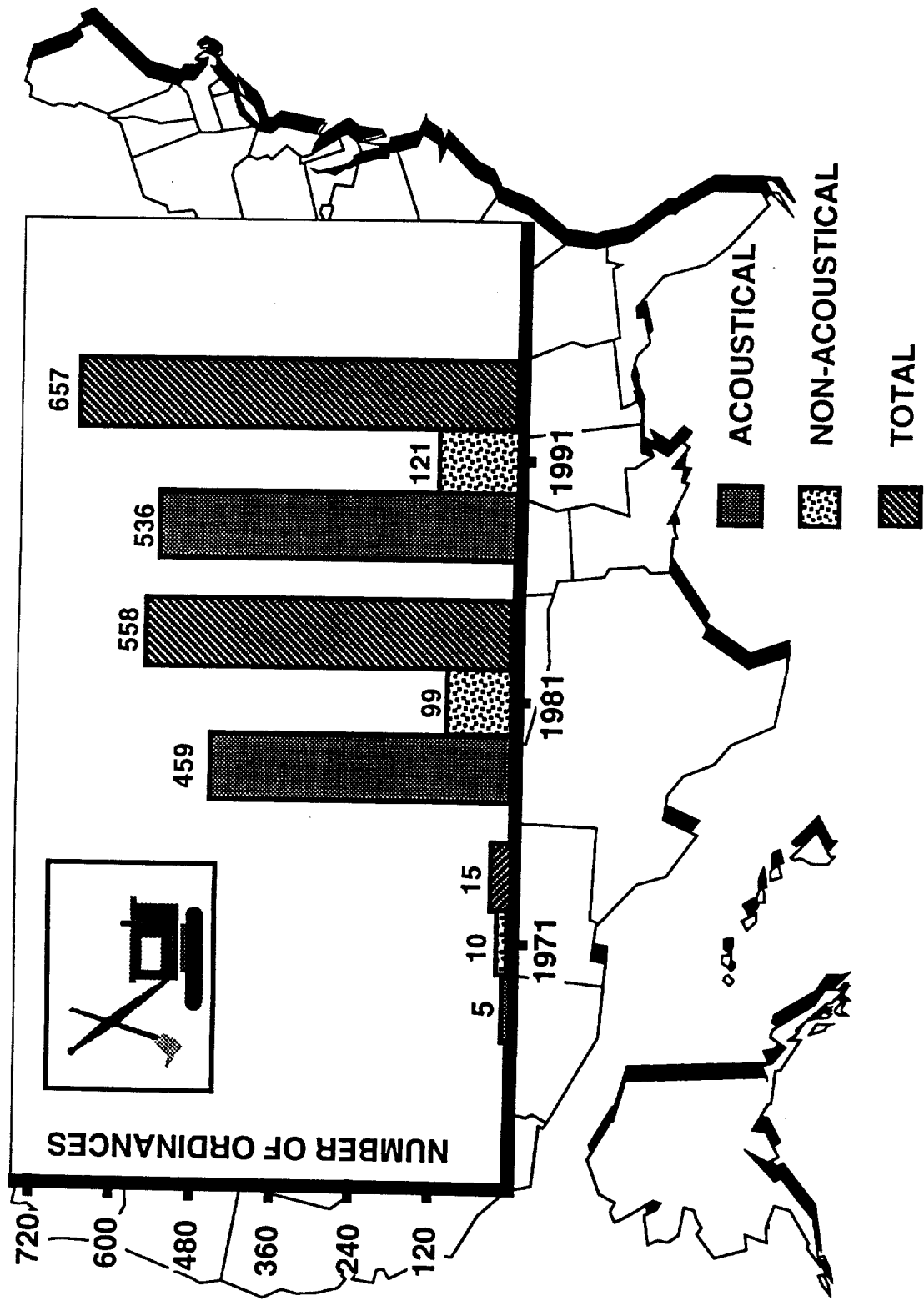

Figure 5.7 Noise ordinance provision: construction.

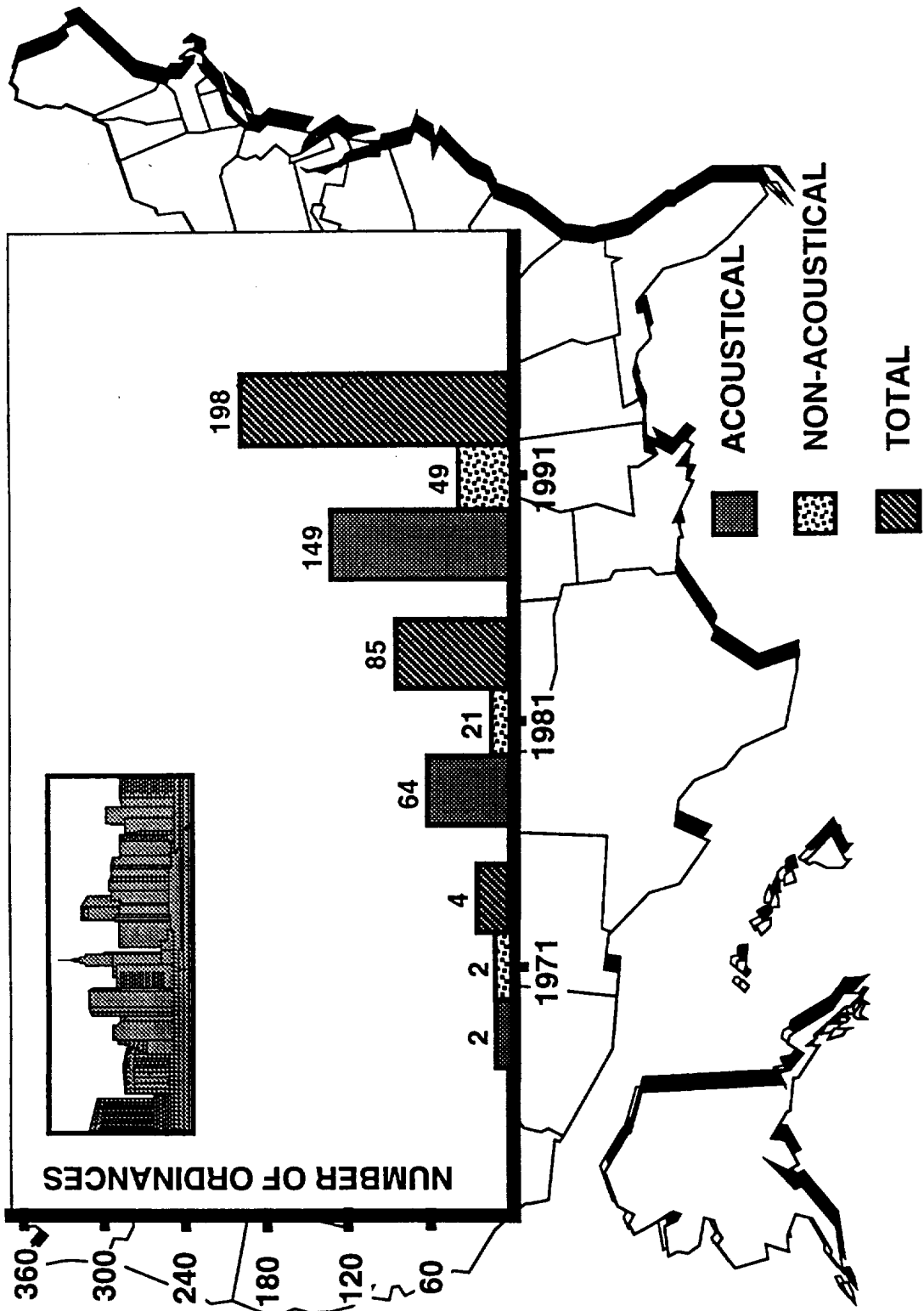

Figure 5.8 Noise ordinance provision: building code.

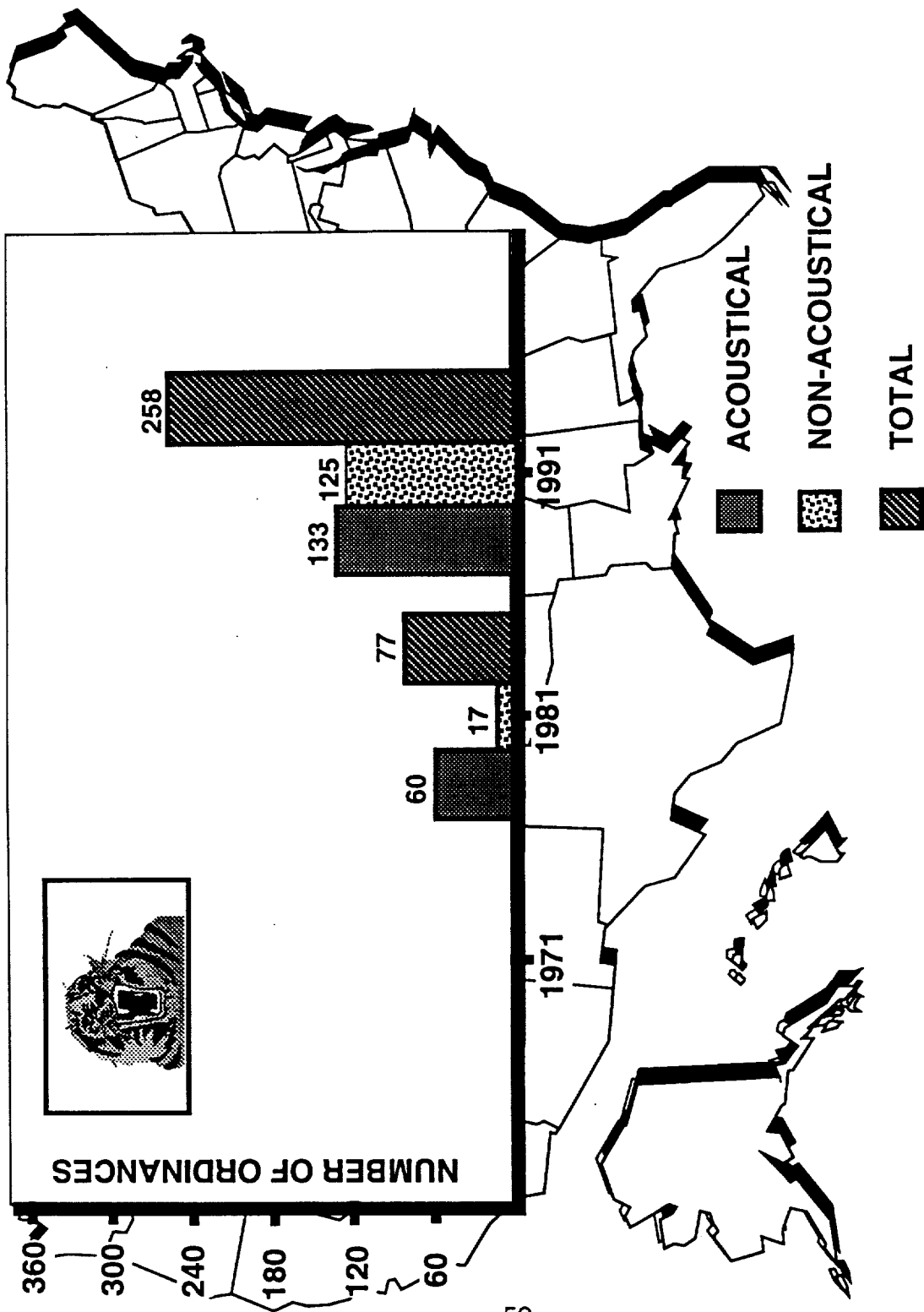

Figure 5.9 Noise ordinance provision: animals.

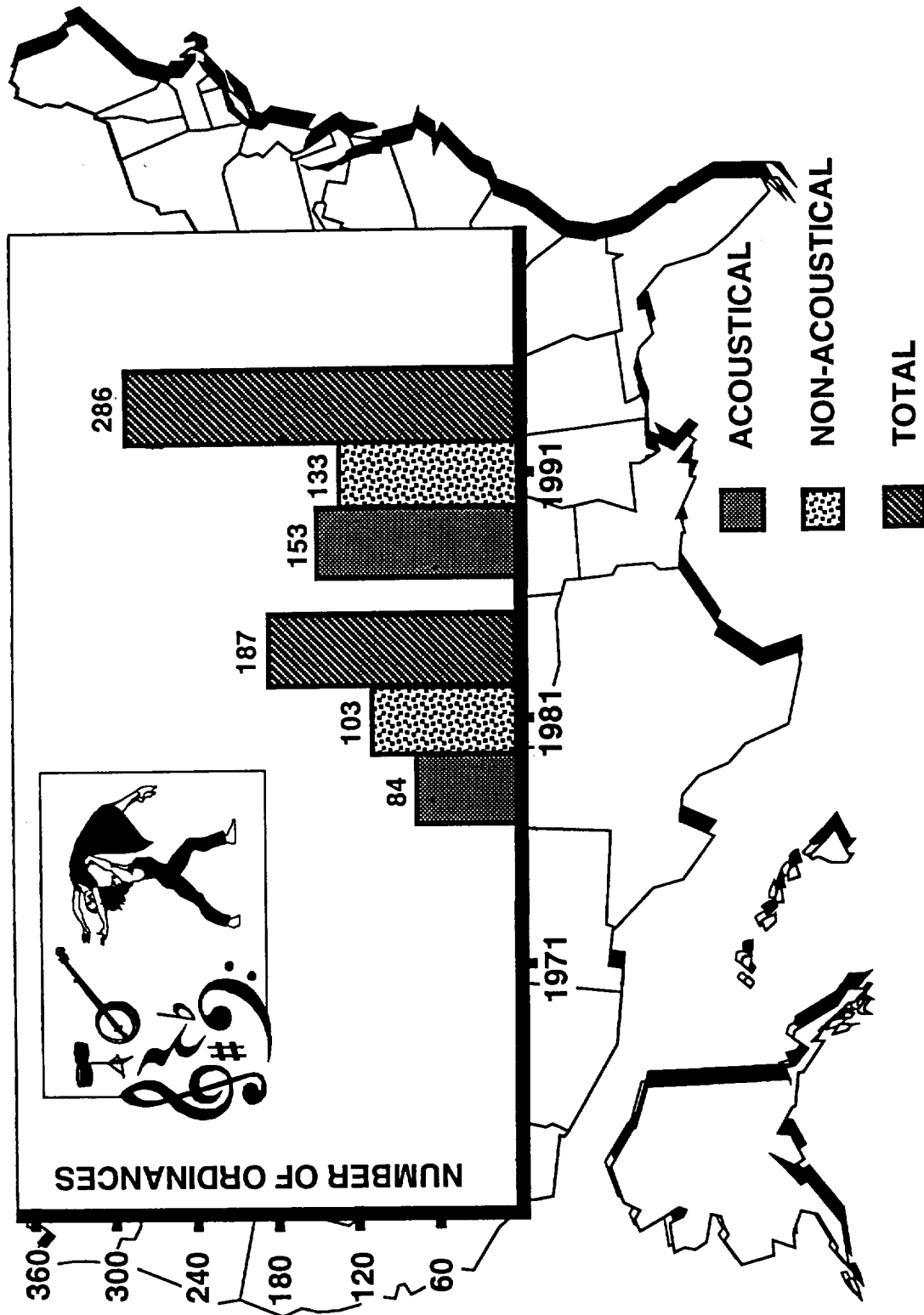

Figure 5.10 Noise ordinance provision: entertainment.

defined noise level in order to be compensated. Only 153, or 10% of the municipalities, have quantitative provisions (Figure 5.10).

Figures 5.1 - 5.10 depict the relative legislative activity growth for the last three decades. The sources of the data for 1971 and 1981 were two earlier environmental surveys [5.2, 5.3]. The present data are the results of a more current survey conducted between September, 1991, and January, 1992 [5.4]. Although the most substantial increase in the number of regulations during the last ten years was in the area of animal related noise and noise associated with railroad activity (465% and 270% respectively), these areas are still modest in number. Only 10.8% of the 1,534 municipalities with noise legislation have provisions that apply to railroad and 16.8% have adopted provisions that apply to animal related noise.

The total number of U.S. municipalities that have enacted some type of noise legislation, by state, is depicted in Table 5.4. Coverage by state varies widely from high percentages in Rhode Island, Hawaii, Connecticut, Massachusetts, New Hampshire and Florida to low percentages in North and South Dakota, Kansas, Nebraska, Oklahoma, Arkansas, and Mississippi. Basically, the east and west coasts have the most comprehensive coverage with the remaining states varying considerably, but usually with lesser number of noise regulations.



Table 5.4 Municipal noise laws by state [5.3, 5.4].

Jurisdiction	Total		Percent Response (%)
	Number	Response	
Alabama	436	15	3.4
Alaska	149	3	2.0
Arizona	81	9	11.1
Arkansas	483	7	1.5
California	442	137	31.0
Colorado	266	24	9.0
Connecticut	31	28	90.3
Delaware	57	3	5.3
District of Columbia	1	1	100.0
Florida	390	146	37.4
Georgia	532	36	6.8
Hawaii	1	1	100.0
Idaho	198	5	2.5
Illinois	1,279	365	28.5
Indiana	567	23	4.1
Iowa	955	17	1.8
Kansas	627	6	1.0
Kentucky	437	10	2.3
Louisiana	301	12	4.0
Maine	22	5	22.8
Maryland	155	8	5.2
Massachusetts	39	25	64.1
Michigan	534	48	9.0
Minnesota	855	24	2.8
Mississippi	293	4	1.4
Missouri	930	52	5.6

Table 5.4 Municipal noise laws by state [5.3, 5.4].

Jurisdiction	Total		Percent Response (%)
	Number	Responses	
Montana	128	8	6.3
Nebraska	534	10	1.9
Nevada	18	3	16.7
New Hampshire	13	5	38.5
New Jersey	320	80	25.0
New Mexico	98	5	5.1
New York	618	57	9.2
North Carolina	495	59	11.9
North Dakota	366	2	0.6
Ohio	940	31	3.3
Oklahoma	591	10	1.7
Oregon	240	40	16.7
Pennsylvania	1,022	30	2.9
Rhode Island	8	8	100.0
South Carolina	269	35	13.0
South Dakota	309	4	1.3
Tennessee	334	15	4.5
Texas	1,156	32	2.8
Utah	225	10	4.4
Vermont	55	1	1.8
Virginia	229	18	7.9
Washington	266	30	11.3
West Virginia	230	4	1.7
Wisconsin	580	15	2.6
Wyoming	95	8	8.4

## 5.4 CONCLUSION

### 5.4.1 Applicability

Noise criteria and standards are utilized by local governments throughout the U.S. in an effort to develop strategies for the abatement of noise. Most of these standards can be evaluated three-dimensionally for space compatibility planning, and therefore, they have immediate application to GIS route impact analysis. As the world's population continues to grow in absolute terms, both the population exposure and distribution of noise will expand.

### 5.4.2 Comprehensiveness

Currently there are 1,534 local governments with noise legislation out of an estimated total of 19,200. These ordinances cover a broad range of sources and deal with several different legal and regulatory controls (i.e. ordinances, codes, performance standards, comprehensive master and land use plans). It is projected that the population of the United States will nearly double within the next 75 years. In addition, rural agricultural land will continue to be converted to residential use. There will be an increase in the number of municipal governments with noise control regulations as the environmental concerns of society grow including the subject of sound pollution. In addition, noise surveillance systems and other environmental sensors will be more common in the future for the purposes of monitoring and enforcement, where legally applicable. Consequently, governmental measures in the noise area appear to be broad in nature, and will increase in importance as population growth and density continues.

### 5.4.3 Future

More noise related laws will be enacted in the future. The use of geographic information systems could well become the key spatially applied technology for plotting noise standards and criteria three-dimensionally for an air route analysis. Noise legislation will aid in the development of a GIS relational data base as at least one layer of information. However, only certain types of laws pertain directly to aircraft overflights. From a preventive standpoint, noise provisions specifically addressing zoning, land use, and building codes will significantly influence the potential impact of aircraft overflights.



**NASA/GT**

AIRCRAFT NOISE ROUTE IMPACT ANALYSIS



# **SECTION 6**

**AIRSPACE OPERATIONAL  
CONTROL  
MEASURES**



## 6.1 INTRODUCTION

### 6.1.1 Purpose

The purpose of Section 6 is to review and inventory aircraft related operational noise control measures that pertain to airspace within the United States and determine the extent to which they can be graphically interfaced with computer systems. Such operational controls should relate to land compatibility from a three-dimensional integrative perspective. Airspace, surface, and subsurface activities related to aircraft and airport operations need to be considered as part of an integrated three-dimensional system.

### 6.1.2 Background: Airspace

Operationally, there are two different types of airspace: controlled and uncontrolled. In the United States controlled airspace is under the jurisdiction of the Federal Aviation Administration (FAA), with air traffic control exercising primary responsibility. Uncontrolled airspace is not under their jurisdiction. The FAA defines uncontrolled airspace as an area within which air traffic control has neither the authority nor the responsibility for exercising control over air traffic [6.1].

Figure 6.1 presents, in a cross-section, the different types of controlled airspace classified as part of the United States airspace system. Controlled airspace is represented by the white, or unshaded areas of this exhibit and includes several components: control zone, airport radar service area, terminal control area, transition area, control area, continental control area, and positive control area. All of these areas may be subject to air traffic control procedures and regulations promulgated by the FAA. Airspace is a three-dimensional term because it contains the dimensions of both vertical height (altitude) and horizontal area. Vertically, controlled airspace extends from the earth's surface up to 60,000 feet in space (FL 600) or altitude. Complete definitions of these areas that are part of controlled airspace are presented in Table 6.1. The spatial relationship of the airport radar service area (ARSA) in terms of both vertical and horizontal distances is contained in Figure 6.2. Such service areas are where the air traffic control tower provides radar information to aircraft as part of the national aircraft radar tracking system. The horizontal service area for ARSA is normally 40 nautical miles from the airport for both instrument flight rules (IFR) and visual flight rules (VFR). See Appendix I for a comprehensive list of defined airspace terms.

Uncontrolled airspace is represented by the shaded area as depicted in Figure 6.1. It extends from the earth's surface to 700 feet where the transition area begins outside the control zone. This area also extends from the ground up to 1,200 feet where federal airways begin and up to 14,500 feet where the continental control area begins.

All airspace is now under the jurisdiction of the FAA, as mandated by the FAA Act of 1958 [6.2]. The goal of this Act was to promote the development of aviation and to

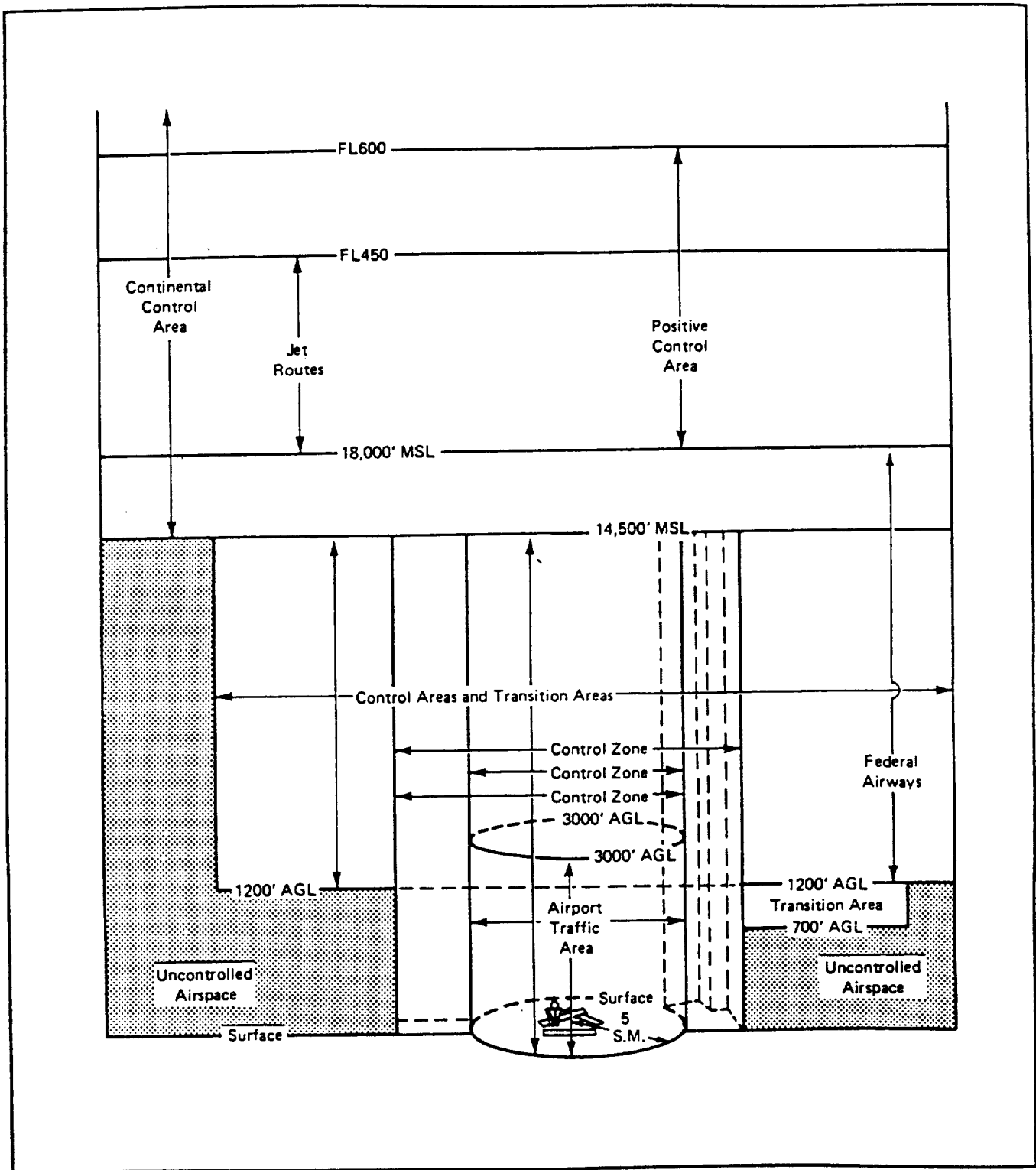

Figure 6.1 U.S. regulated airspace [6.4].



Table 6.1 Definition of controlled airspace [6.4].

**CONTROLLED AIRSPACE**—Airspace designated as a control zone, airport radar service area, terminal control area, transition area, control area, continental control area, and positive control area within which some or all aircraft may be subject to air traffic control. (Refer to AIM) (Refer to FAR 71)—  
Types of U.S. Controlled Airspace:

1. **Control Zone.** Controlled airspace which extends upward from the surface of the earth and terminates at the base of the continental control area. Control zones that do not underlie the continental control area have no upper limit. A control zone may include one or more airports and is normally a circular area with a radius of 5 statute miles and any extensions necessary to include instrument approach and departure paths.
2. **Airport Radar Service Area [ARSA].** Regulatory airspace surrounding designated airports wherein ATC provides radar vectoring and sequencing on a full-time basis for all IFR and VFR aircraft. The service provided in an ARSA is called ARSA service which includes: IFR/IFR-standard IFR separation; IFR/VFR-traffic advisories and conflict resolution; and VFR/VFR-traffic advisories and, as appropriate, safety alerts. The AIM contains an explanation of ARSA. The ARSA's are depicted on VFR aeronautical charts. (See Conflict Resolution) (See Outer Area) (Refer to AIM) (Refer to Airport/Facility Directory) (Refer to FAR 91)
3. **Terminal Control Area [TCA].** Controlled airspace extending upward from the surface or higher to specified altitudes, within which all aircraft are subject to operating rules and pilot and equipment requirements specified in FAR 91. TCA's are depicted on Sectional, World Aeronautical, En Route Low Altitude, DOD FLIP, and TCA charts. (Refer to FAR 91) (Refer to AIM)
4. **Transition Area.** Controlled airspace extending upward from 700 feet or more above the surface of the earth when designated in conjunction with an airport for which an approved instrument approach procedure has been prescribed; or from 1,200 feet or more above the surface of the earth when designated in conjunction with airway route structures or segments. Unless otherwise specified, transition areas terminate at the base of the overlying controlled airspace. Transition areas are designed to contain IFR operations in controlled airspace during portions of the terminal operation and while transiting between the terminal and en route environment.
5. **Control Area.** Airspace designated as Colored Federal airways, VOR Federal airways, control areas associated with jet routes outside the continental control area (FAR 71.161), additional control areas (FAR 71.163), control area extensions (FAR 71.165), and area low routes. Control areas do not include the continental control area, but unless otherwise designated, they do include the airspace between a segment of a main VOR Federal airway and its associated alternate segments with the vertical extent of the area corresponding to the vertical extent of the related segment of the main airway. The vertical extent of the various categories of airspace contained in control areas is defined in FAR 71.
6. **Continental Control Area.** The airspace of the 48 contiguous States, the District of Columbia and Alaska, excluding the Alaska peninsula west of Long. 160° 00' 00"W, at and above 14,500 feet MSL, but does not include:
  - a. The airspace less than 1,500 feet above the surface of the earth; or
  - b. Prohibited and restricted areas, other than the restricted areas listed in FAR 71.
7. **Positive Control Area [PCA].** Airspace designated in FAR 71 within which there is positive control of aircraft. Flight in PCA is normally conducted under instrument flight rules. PCA is designated throughout most of the conterminous United States and its vertical extent is from 18,000 feet MSL to and including flight level 600. In Alaska PCA does not include the airspace less than 1,500 feet above the surface of the earth nor the airspace over the Alaska Peninsula west of longitude 160 degrees West. Rules for operating in PCA are found in FAR 91.135 and FAR 91.215.

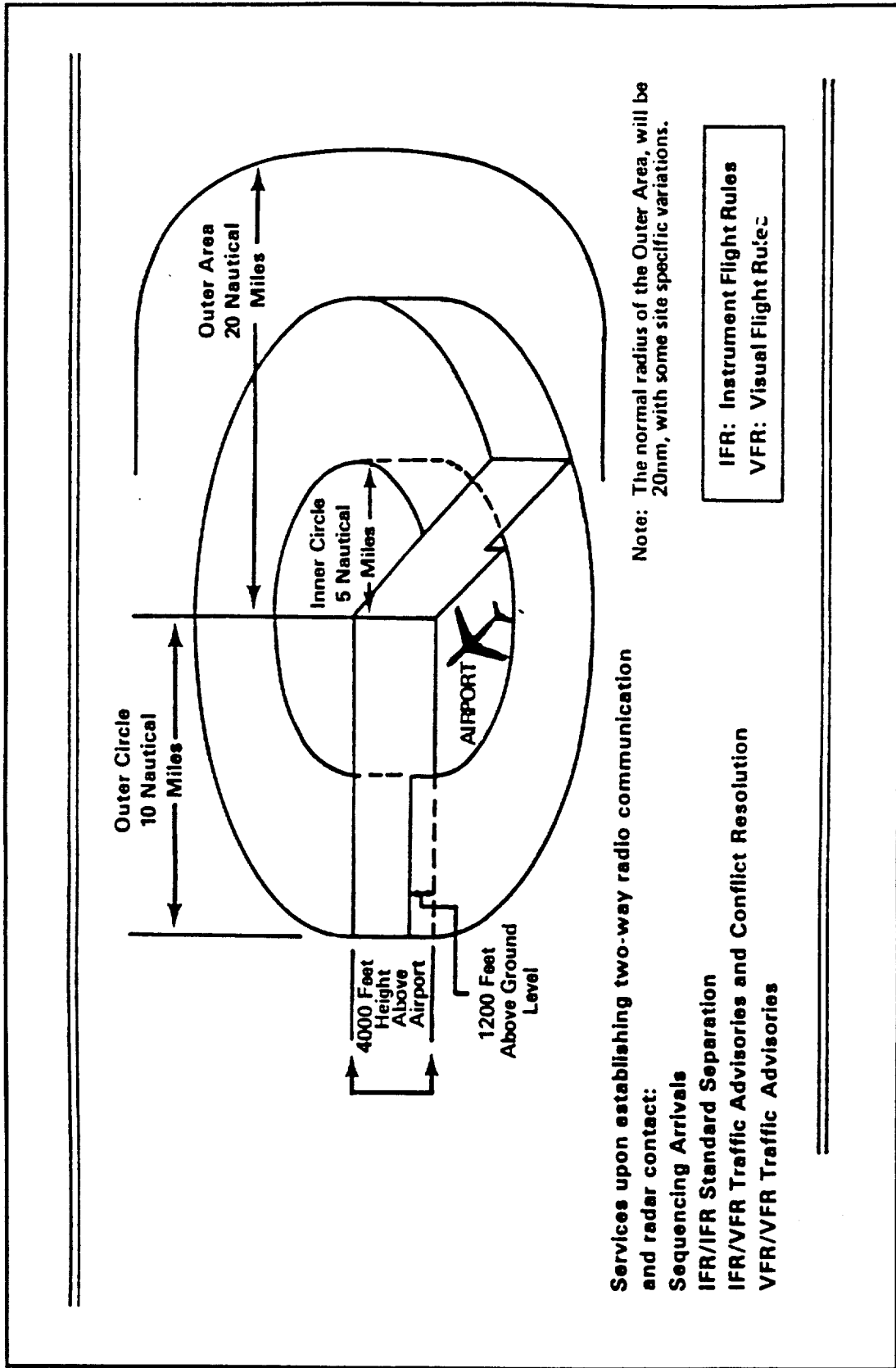

Figure 6.2 Airport radar service area (ARSA).

protect the public health, safety, and welfare. Because air travel crosses state boundaries, aviation involves interstate commerce. Therefore, it falls under federal control rather than any smaller governmental entity. Consequently, all other levels of government are preempted by the FAA in controlling airspace. The FAA became the regulatory authority for managing all navigable airspace with the passage of the 1958 Act [6.2].

Property is part of three distinct but related planes. There is the aerial plane that includes airspace along with the surface and subsurface planes. Figure 6.3 shows the relationship between these three planes and the right a property owner has to legally use these planes. The FAA acts as both the steward and manager of navigable airspace with the property owner limited in their use, generally 50 to 200 feet above their structure, or surface plane. In most instances aircraft do not enter this airspace above the structure and trespass this vertical property boundary. The owner does have avigational rights that are part of the bundle of rights that protect the use of his or her property. Noise can be a potential trespass because it may penetrate through this three-dimensional property boundary thereby possibly affecting the associated land use. Historically, property ownership included the area from the center of the earth to infinity. However, the broad spatial definition of private property has become restricted as public interest has grown. Figure 6.4 shows how a private residence may relate to these three planes. In addition a profile of ownership is presented in terms of public/private rights and ownership for a residential property. In this illustrated example, only the operational use of the surface and a limited distance above and below it are privately owned. Private right to airspace usually ends at a vertical distance of 50 to 200 feet above the ground surface and as long as it does not interfere with the safe movement of aircraft.

The spatial aspect of property and ownership rights is very complex and varies depending upon the region of the country. However, airspace operational controls have significant relationships to all other sections of this project.

### 6.1.3 Interrelationships

In varying degrees Section 6 is related to all other project sections. As illustrated by the matrix of sectional relationships (Table 6.2), Section 6 is most closely related to Sections 3 and 7 because they are concerned with noise terminology and aircraft procedures, respectively. Section 3 includes sound metrics, descriptors, and noise prediction models. These noise related terminologies are relevant to noise abatement procedures which constitute a large portion of airspace operational controls. Federal regulations and advisory circulars that pertain to route analysis are included in Section 6. They supplement operational control measures. To a lesser extent, Section 6 is related to the other sections: 2, 4, 5, 8, and 9. Airspace operational control measures potentially could be incorporated into a Geographic Information System, or GIS (Section 2). There is an increasing trend toward the use of GIS in attempting to represent three-dimensional data as part of the airport planning process. The data from other sections such as Land

# AVIGATIONAL CONSTRAINTS: FAA INTERSTATE COMMERCE

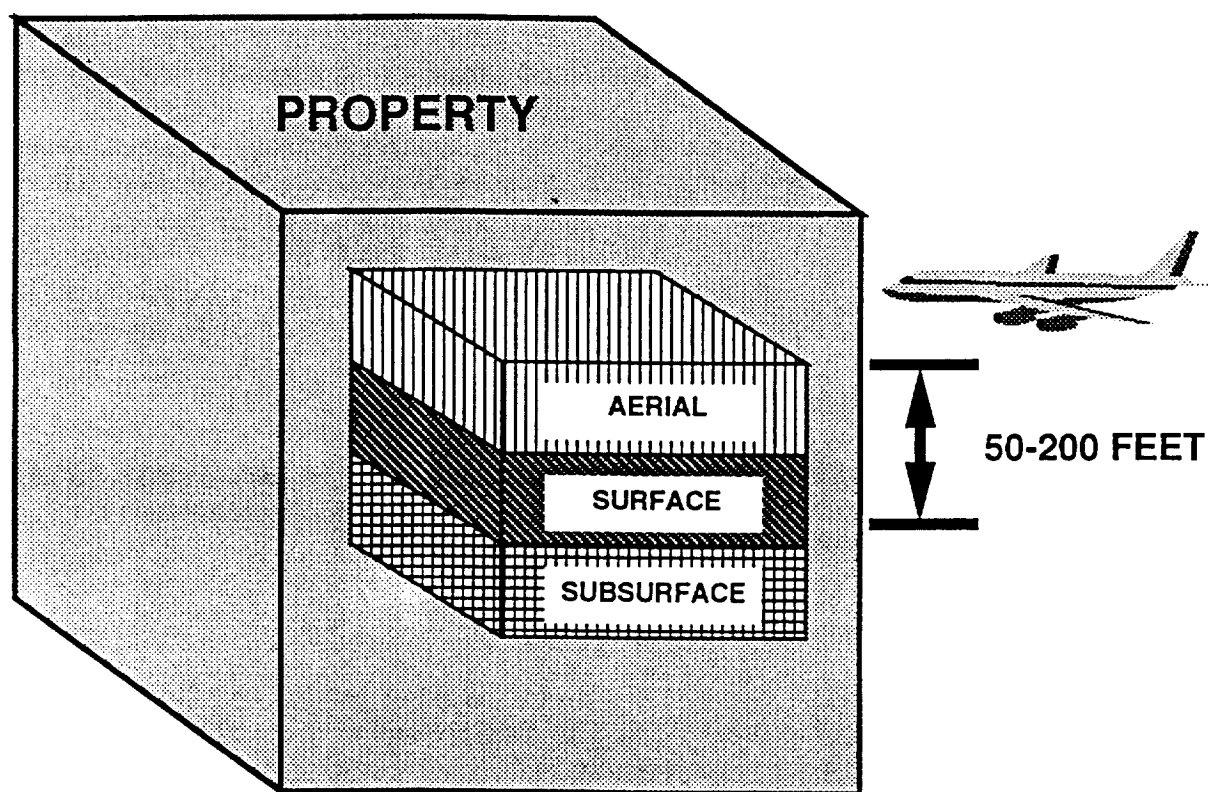

Figure 6.3 Three - dimensional property rights.

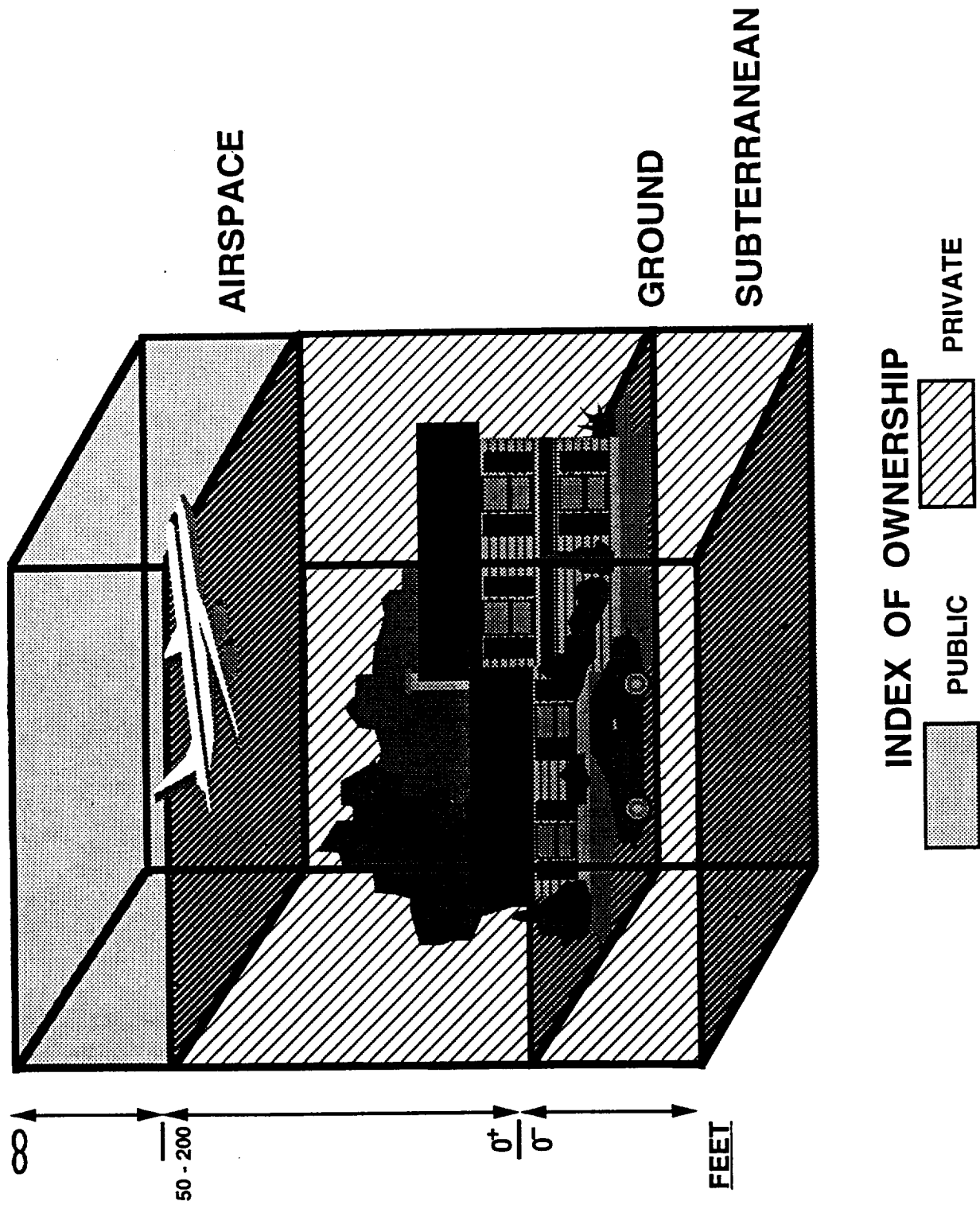

Figure 6.4 An example of three - dimensional property ownership.

Use Data (Section 4) and Census, Demographics, and Real Estate Data (Section 8) can also be part of a GIS. All of the relationships appear to be very important in developing any route methodology for aircraft.

Table 6.2 Interrelationship between aircraft operational control measures and other sections.

<u>Section</u>	<u>Name</u>	<u>Level of Relationship</u>
2	Geographic information systems	R2
3	Sound metrics and descriptors	R1
4	Land Use databases	R1
5	Governmental regulatory data bases	R1
7	Federal regulations and advisory circulars circulars pertaining to route analysis	R1
8	Census, demographics, and real estate based analysis	R2
9	Environmental Attributes	R2

- R1 - Major relationship
- R2 - Moderate relationship
- R3 - Minor relationship
- R4 - No relationship

#### 6.1.4 Relevance

Section 6 is extremely important. It deals with the operational controls of aircraft which relate to noise control in a three-dimensional universe. The objective of this section is to identify and evaluate these regulations and operational control measures that are of a spatial nature. As noted, these regulations can be incorporated into a GIS as single or multiple layers of information. The data bases from other sections can likewise make up additional GIS layers. Collectively, these layers make up a whole that will describe the most relevant information relating to airspace route analysis.

## 6.2 METHODOLOGY

The two main areas of inquiry were airspace and operational control measures. Airspace has been discussed in the background section and was the first area to be investigated. Through interviews with the FAA and literature searches, information was gathered which emphasized graphic illustrations and aviation technology. Contributing significantly to this airspace investigation was an interview with Russ Gausman of the FAA, and material contained in The Airman's Information Manual [6.3].

Operational controls were the second area of investigation. This involved a search of aviation and related airport literature. Two major airport surveys were obtained and used to classify operational controls. One of these surveys was compiled by the National Business Aircraft Association (NBAA). They compile an annual survey of all airports having a hard surface runway over 3,000 feet that report the use of noise advisories [6.4].

The 1991 edition of the NBAA survey, which included 562 airports, was thoroughly examined. This information was converted into a data base. Additional information was obtained from a recent national survey of 5,000 municipalities conducted by C.R. Bragdon at Georgia Institute of Technology [6.5]. The output of these two surveys were combined resulting in an inventory of 574 airports.

All control measures identified in these surveys have been codified in the data base and represent the headings for 28 different data base fields. The definitions of each data base field heading are included in Appendix J. Those control measures, or data base fields which have a spatial aspect have been further defined and analyzed. The definitions of the 20 spatial field names are listed below in Table 6.3. For clarity, both data base field names and common names are given for each term.

Table 6.3 - Definitions of three-dimensional operational control measures.

Field Name (common name) --definition

1. NEM (Noise exposure map)--Map delineating the noise level contours of aircraft operations in the airport and surrounding area
2. NCP (Noise compatibility program)--Program designed to abate noise
3. NOISE PERM (Permanent noise monitoring station)--Station that exists in the airport for the purpose of measuring noise levels of aircraft operations
4. RUNUP (Aircraft maintenance procedures)--Procedures involving maintenance of aircraft that occur on the ground; they may involve running aircraft engines at certain thrusts
5. ACTRAINING (Aircraft training)--Training procedures such as touch and goes that often involve repetitive operations
6. EVEN REST (Evening restrictions)--Restrictions on aircraft type or aircraft operation during the evening (1900-2200 hours)
7. NIGHT REST (Night restrictions)--Restrictions on aircraft type or aircraft operation during the night (2200-0700 hours)
8. CURFEW (Curfew)--A specified time when some or all operations end
9. BAN (Ban)--The elimination of certain aircraft or operations from the airport
10. PREF RUNWAY (Preferential runway)--The use of a preferential runway especially for noise abatement or weather conditions
11. LANDING PROCED (Landing procedures)--The use of certain flight patterns when landing to abate noise

12. TAKEOFF PROCED (Takeoff procedures)--The use of certain flight pattern when taking off to abate noise
13. DISPLAY THRESHOLD (Display threshold)--Higher altitude landings and takeoffs used for noise abatement
14. SENSITIVE AREAS (Sensitive areas)--Noise sensitive areas that have been identified in the surrounding airport area; they are avoided by the use of landing and takeoff procedures and other noise abatement activities
15. ALT REST FIXED (Altitude restrictions, fixed wing)--Altitude restrictions for fixed wing aircraft, such restrictions are to avoid vertical obstructions and for noise abatement
16. ALT REST HELI (Altitude restrictions, helicopters)--Altitude restrictions for helicopters for the purpose of avoiding vertical obstructions and noise abatement
17. AIRCRAFT TYPE (Aircraft type)--Type of aircraft
18. ENGINE TYPE (Engine type)--Type of engine
19. PART 77 (FAR Part 77 requirements)--Requirements set by the Federal Aviation Administration that involve vertical obstructions
20. PART 93 (FAR Part 93 requirements)--Requirements set by the Federal Aviation Administration that involve flight patterns.

### 6.3 FINDINGS

#### 6.3.1 General Classifications

The purpose of operational control measures is to abate noise, and to make air travel as safe and efficient as possible. Those operational control measures that have a spatial dimension have been classified in five different ways: the number of airports using spatially related optional control measures, the method of control, the plane of control, the location of control (on or off-airport), and spatial dimension (two or three-dimensional).

The first classification is a rank order listing of the number of airports by operational control measure. These findings are presented in Table 6.4. As the table indicates, noise exposure maps are the most popular operational control measure; 113 airports use such maps. Typically the maps are generated as part of an approved FAA Part 150 Airport Noise and Land Use Planning Program [6.6]. Takeoff and landing procedures along with noise compatibility related measures are the next most common group of operational control measures. These involve both actual flight operations as well as static operations (i.e. runup activity). The remaining seven control measures cited in the table represent less than two percent of the airports surveyed.

Methods for controlling noise represents the second classification. Each control measure was analyzed to determine if the noise control location was at the source, path, or receiver position (Table 6.5). The noise source is the noise generator, such as the aircraft engine or air frame. A noise path is the area where the noise travels from the source through space, usually through the medium of air. Lastly a person or structure



represents the receiver position. As indicated in Table 6.5, most operational controls occur at all three locations of control, source, path, and receiver. For example, the institution of a noise exposure map can be used for consumer information for real estate transactions or developing a comprehensive land use plan to avoid future incompatible receiver sites.

Each control measure was then analyzed to determine if it occurred in the aerial, surface, or subsurface plane (Table 6.6). Most control measures occurred on the surface; however, there were exceptions. Noise compatibility programs, for example, may include the subsurface. Such programs could involve building structures both on the surface and beneath the ground to avoid noise impact. One such example is the use of the subsurface area at London's Gatwick Airport. At Gatwick, an earth berm was constructed for noise abatement. Integrated into this earth berm constructed for noise control was a multi-level utility substation that was earth sheltered (i.e. partially above and below the ground). Earth sheltered structures near airports provide an additional amount of sound reduction or attenuation than comparably built facilities constructed at grade.

The fourth control measure determined if the location of control occurred off-airport or on-airport (Table 6.7). On-airport controls refer only to controls occurring on fee title airport property. An example of control occurring on the airport property would be runup activity. Runup refers to aircraft maintenance procedures that take place at a fixed and static location on the airport property, usually in a designated run-up area. Off-airport controls refer to the airspace and land surrounding the airport. An example of such a control is a landing procedure. Landing procedures occur in the airspace initiated well beyond the airport boundaries. A majority of control measures involve both on and off airport locations. Some, such as noise sensitive areas are off-airport, because they are defined as residential, institutional and/or commercial land uses situated beyond the airport property boundaries.

Finally, these control measures were evaluated in terms of their spatial dimension. They were classified as 2D, 2DM, or 3D (Table 6.8). Two-dimensional (2D) refers to controls that occur in a two-dimensional field defined by length, width, and area. Two-dimensional modified (2DM) refers to two-dimensional controls that have topographical elements such as area and elevation. Three-dimensional includes area and elevation but also vertical interaction since it shows the relationship between the three spatial planes: aerial, surface and subsurface. Noise exposure maps are the only control measure that are classified as 2DM. Such maps may have topographical elements represented in them. All control measures are referred to as being two-or-three dimensional, but not both. As presented in this table these controls fall into one of three spatial categories. Figure 6.5 represents is graphic depiction of the spatial relationships of operational control measures.

### 6.3.2 Specific Description of Operational Control Measures

**SPATIAL  
DIMENSION**

**DESCRIPTION**

2D



2DM

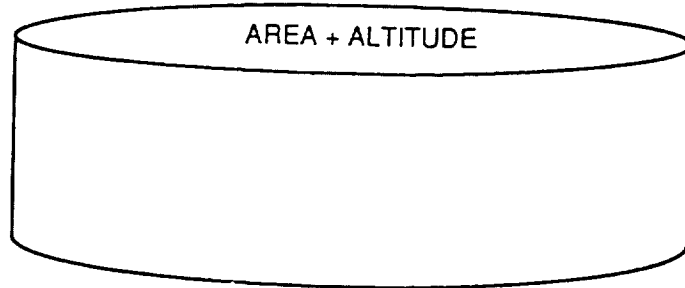

3D

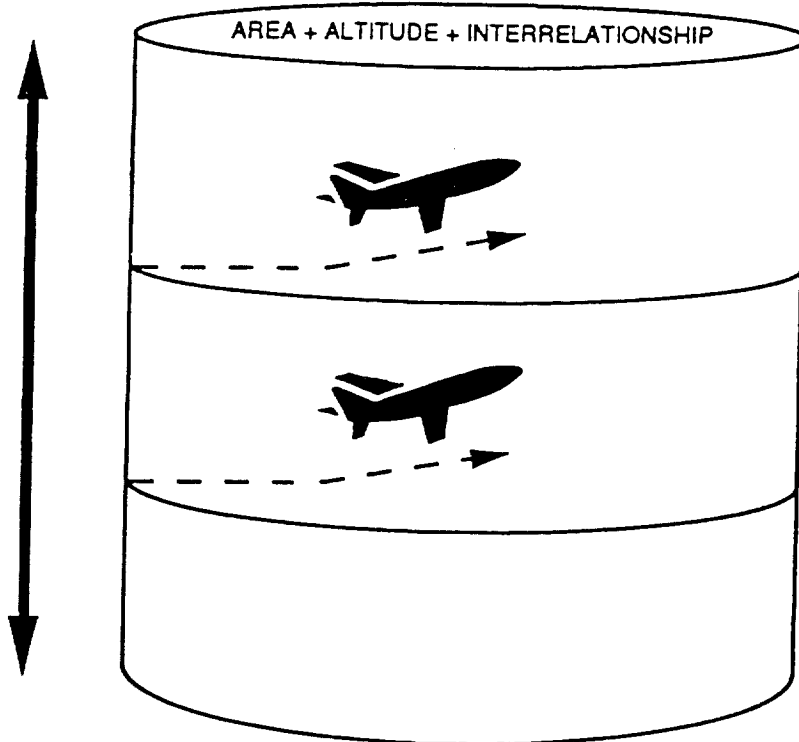

Figure 6.5 Spatial relationship and operational control measures.

Six of the most important control measures among the original 20 inventoried are further described and illustrated in the following section. They include:

1. Noise perm (Permanent noise monitoring system)
2. Runup (Aircraft maintenance procedures)
3. Actraining (Aircraft Training)
4. Curfew
5. Pref Runway (Preferential Runway)
6. Landing proceed (Landing Procedures)/Takeoff proceed (Takeoff Procedures)

1. Noise perm - (Permanent noise monitoring system)--The use of a 24-hour noise monitoring system for measurement purposes. Such systems serve a variety of purposes such as assessing alternative flight procedures for noise control, assisting in the investigation of specific public inquiries and complaints, and assisting in addressing land-use planning and noise-impact issues. These systems have four primary components: a series of remote monitoring stations, central processing station, computer software, and graphic map terminal(s). Remote monitoring stations are fixed stations that physically measure airborne-generated noise and include a microphone for every outdoor noise monitoring location. This acoustical information is then relayed to the central processing station which receives, analyzes, and stores the data using a computer based system. Software then continues the processing stage and can portray the data electronically using graphic display terminals or geographic maps depicting sound levels in the vicinity of the airport. In the United States there are 28 noise monitoring systems in place at airports, with additional ones coming on line in the future.

2. Runup - (Aircraft maintenance procedures)--Runup refers to the conducting of aircraft maintenance procedures, such as static tests requiring thrust or engine power settings. Such tests may cause a noise impact to the area beyond the airport boundaries. Many airports maintain such facilities but they may be subject to operational controls. Restrictions typically apply to: overall noise limits, time of day, location, and site design. Figure 6.6 illustrates the runup noise contour overlaid onto an airport. It shows the noise contours that aircraft maintenance procedures may create. Noise contours depending on the runup site can penetrate into noise sensitive areas (e.g. residential land use), as the illustration depicts. Often these runup areas either have to be relocated to less noise sensitive areas, or they are acoustically buffered or aircraft are contained with a portable suppressor or permanent structure.

3. Actraining - (Aircraft training)--These activities are a major source of regulation by airports. The reasons for such regulation are several: safety, unusual time occurrences, repetitive flight activities, and sound level. Safety is important because accident potential is elevated when training flights are interspersed with normal flight operations. Aircraft training can contribute significantly to the integrated noise level at an airport, especially

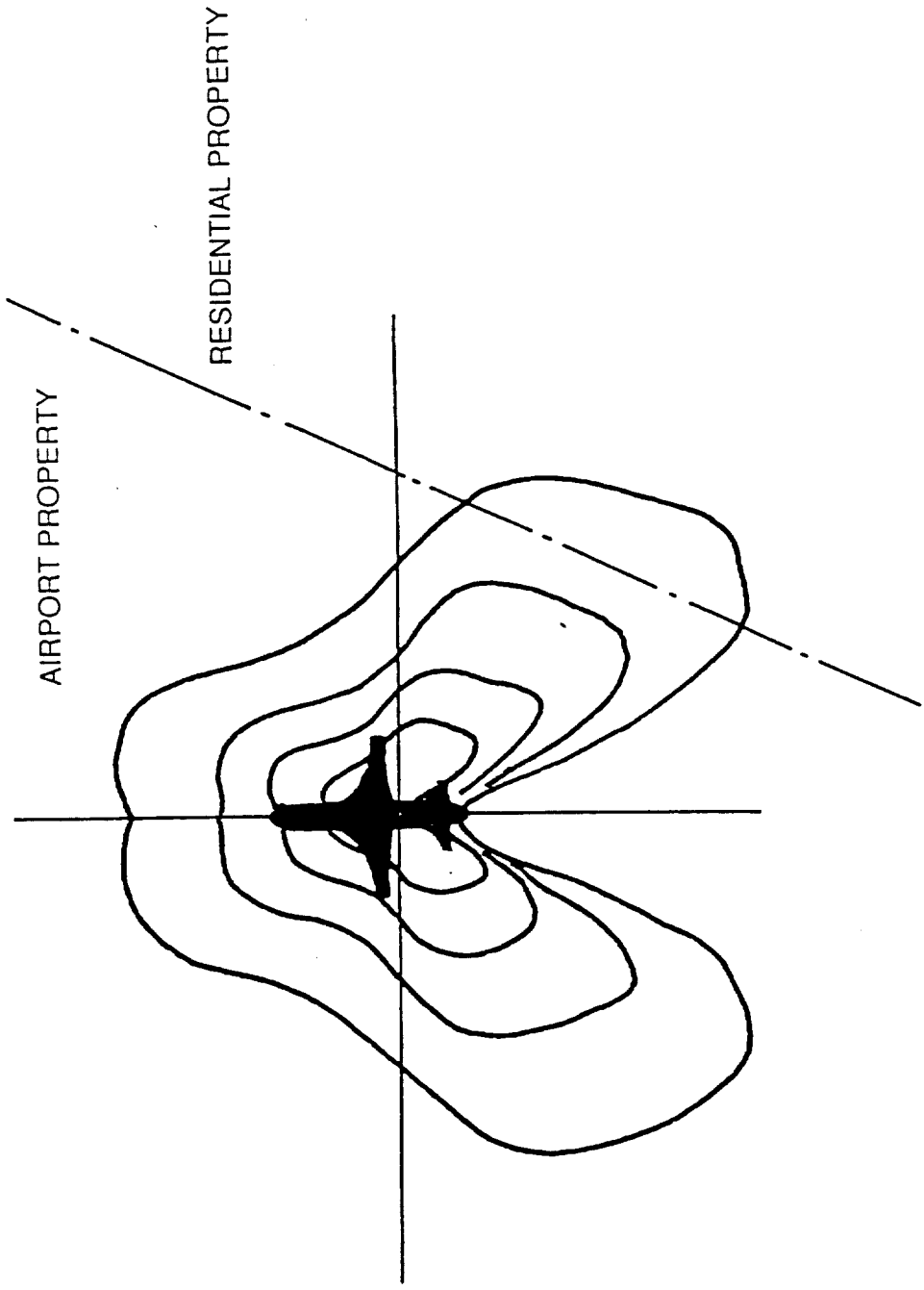

Figure 6.6 Operational controls: ground runup restrictions.

when there are a large number of operations (e.g. touch and goes).

4. Curfew - A curfew refers to a temporal control that applies to the period aircraft are permitted to operate. This may be in the form of a restriction between certain hours such as at the Washington National Airport which has a curfew on all flights between 2200-0659. Other controls may include a ban or limit on: the type of aircraft, type of operation, or the total number of operations. Such controls are considered to be the most severe form of noise control because of the economic consequences for the industry and possibly the economic base of the community. Curfews may occur at any time although the example of a night curfew is more frequent, usually instituted between 2200-0700 hours. Since the passage of the Airport Noise Capacity Act there are now restrictions placed on the type and number of controls that can be used at an airport. Most airports are grandfathered, and no new controls can be initiated without significant justification [6.7].

5. Pref Runway - (Preferential Runway)--Selective runway use may enable jets to avoid certain noise sensitive areas. Smaller airports with only a single runway system are unable to use this technique. By instituting such an operational strategy it may reduce the sound level of a runway closer to a residential population, thereby offering some relief to the affected residents.

6. Landing procedure/Takeoff procedure - The manner in which a fixed wing aircraft must operate during takeoff or landing is heavily influenced by noise abatement procedures. Depending upon the airport's takeoff procedure the aircraft will retract flaps or cleanup and reduce the thrust to a specified setting. Typically the pilot uses a high thrust in the beginning and then reduces power to minimize noise impact. Such procedures will help abate noise and depend on the noise sensitive areas located near the airport. This allows an aircraft to achieve its altitude as fast as possible thereby avoiding an extended area of more intense noise. Although this can reduce the area exposed to high levels, it may well increase the area exposed to lower noise levels. Procedures for landing fixed wing aircraft can also reduce noise, particularly at a higher level of intensity. The FAA recommends the use of a 3 degree glide slope on approach to minimize noise especially on the ground. This keeps aircraft at a higher than usual altitude, thereby reducing ground noise exposure for the longest possible period.

## 6.4 CONCLUSION

### 6.4.1 Applicability

Operational control measures are utilized throughout the national airport system to minimize aircraft community impact. Most of these measures are used currently as a three dimensional tool, therefore, they have immediate application to a spatially based route impact analysis. There will be additional operational control measures used at

airports in the future. More airports will benefit from such measures by reducing noise. In addition, new methods will be created to increase the effectiveness of noise abatement programs. This will be stimulated in part by the FAA Airport Noise and Land Use Planning Part 150 program which provides funding of airport plans that establish noise exposure maps and noise compatibility programs. Current funding for this program amounts to \$33.5 million and to date 208 airports have received FAA supported grants amounting to over \$1.204 billion dollars [6.7].

#### 6.4.2 Comprehensiveness

Currently there are 574 airports using operational controls out of an estimated total of 20,000 airports. As the United States population increases, along with the demand for further air travel more airports and adjacent communities will enact controls. Such controls, however, cannot be discriminatory nor can they interfere with the FAA responsibilities. With the United States population projected to nearly double within 75 years along with more rural land conversion to residential use, operational controls will become increasingly important. There are now limits being placed on the type and number of control measures that can be implemented at the local level due to enacted federal legislation [6.7].

#### 6.4.3 Future

As noted more airspace operational controls will be required in the future due to population growth and the increase in aviation demand. The use of geographic information systems will be a key in plotting operational controls three dimensionally for air route analysis. Currently such use is not widespread, but, in the future operational controls will be part of a GIS as a layer of information. Another major advance will take place when GIS and CAD systems and data bases become compatible and interactive. The result will be improved computer-based graphics that will be of considerable assistance in airport community planning and noise route evaluation.

Table 6.4 Aircraft operational control measures.

CONTROL MEASURE	NUMBER	PERCENTAGE
Noise Exposure Maps	113	16.7
Takeoff Procedures	91	13.5
Noise Sensitive Areas	81	11.9
Noise Compatibility Programs	81	11.9
Flight Training	56	8.3
Landing Procedures	52	7.7
Preferential Runway	49	7.2
Runup	48	7.1
Noise Monitoring Systems	28	4.1
Altitude Restrictions: Fixed Wing	22	3.2
Curfew	13	1.9
Part 77	12	1.7
Aircraft Type	11	1.6
Aircraft Ban	7	1
Engine Type	6	.9
Altitude Restrictions: Helicopter	4	.6
Displaced Threshold	2	.3
TOTAL	676	100

Sample Size: 574 airports

Table 6.5 Aircraft operational control measures:  
control strategy.

CONTROL MEASURES	SOURCE	PATH	RECEIVER
Noise Exposure Maps			X
Takeoff Procedures	X	X	X
Noise Sensitive Areas			X
Noise Compatibility Programs	X	X	X
Flight Training	X		X
Landing Procedures	X	X	X
Runup	X	X	X
Noise Monitoring Systems			X
Altitude Restrictions: Fixed Wing	X	X	X
Curfew	X	X	X
Part 77			X
Aircraft Type	X	X	X
Aircraft Ban	X	X	X
Engine Type	X	X	X
Altitude Restrictions: Helicopter	X	X	X
Displaced Threshold	X	X	X



Table 6.6 Aircraft operational control measures:  
spatial plane.

CONTROL MEASURES	AERIAL	SURFACE	SUBSURF
Noise Exposure Maps		X	
Takeoff Procedures	X	X	
Noise Sensitive Areas		X	
Noise Compatibility Programs	X	X	X
Flight Training	X	X	
Landing Procedures	X	X	
Preferential Runway	X	X	
Runup		X	
Noise Monitoring Systems		X	
Altitude Restrictions: Fixed Wing	X		
Curfew	X	X	
Part 77	X		
Aircraft Type		X	
Aircraft Ban	X	X	
Engine Type		X	
Altitude Restrictions: Helicopters	X		
Displaced Threshold	X	X	

Table 6.7 Aircraft operational control measures:  
location of control.

CONTROL MEASURE	OFF AIRPORT	ON AIRPORT
Noise Exposure Maps	X	X
Takeoff Procedures	X	X
Noise Sensitive Areas	X	
Noise Compatibility Programs	X	
Flight Training		X
Landing Procedures	X	X
Preferential Runway		X
Runup		X
Noise Monitoring Systems	X	X
Altitude Restrictions: Fixed Wing	X	X
Curfew		X
Part 77	X	X
Aircraft Type		X
Aircraft Ban		X
Engine Type		X
Altitude Restrictions: Helicopter	X	X
Displaced Threshold		X

Table 6.8 Aircraft operational control measures:  
spatial dimension.

CONTROL MEASURE	2D	2DM	3D
Noise Exposure Maps		X	
Takeoff Procedures			X
Noise Sensitive Areas	X		
Noise Compatibility Programs	X		
Flight Training			X
Landing Procedures			X
Preferential Runway			X
Runup	X		
Noise Monitoring Systems	X		
Altitude Restrictions: Fixed Wing			X
Curfew			X
Part 77			X
Aircraft Type	N/A	N/A	N/A
Aircraft Ban			X
Engine Type	N/A	N/A	N/A
Altitude Restrictions: Helicopter			X
Displaced Threshold			X

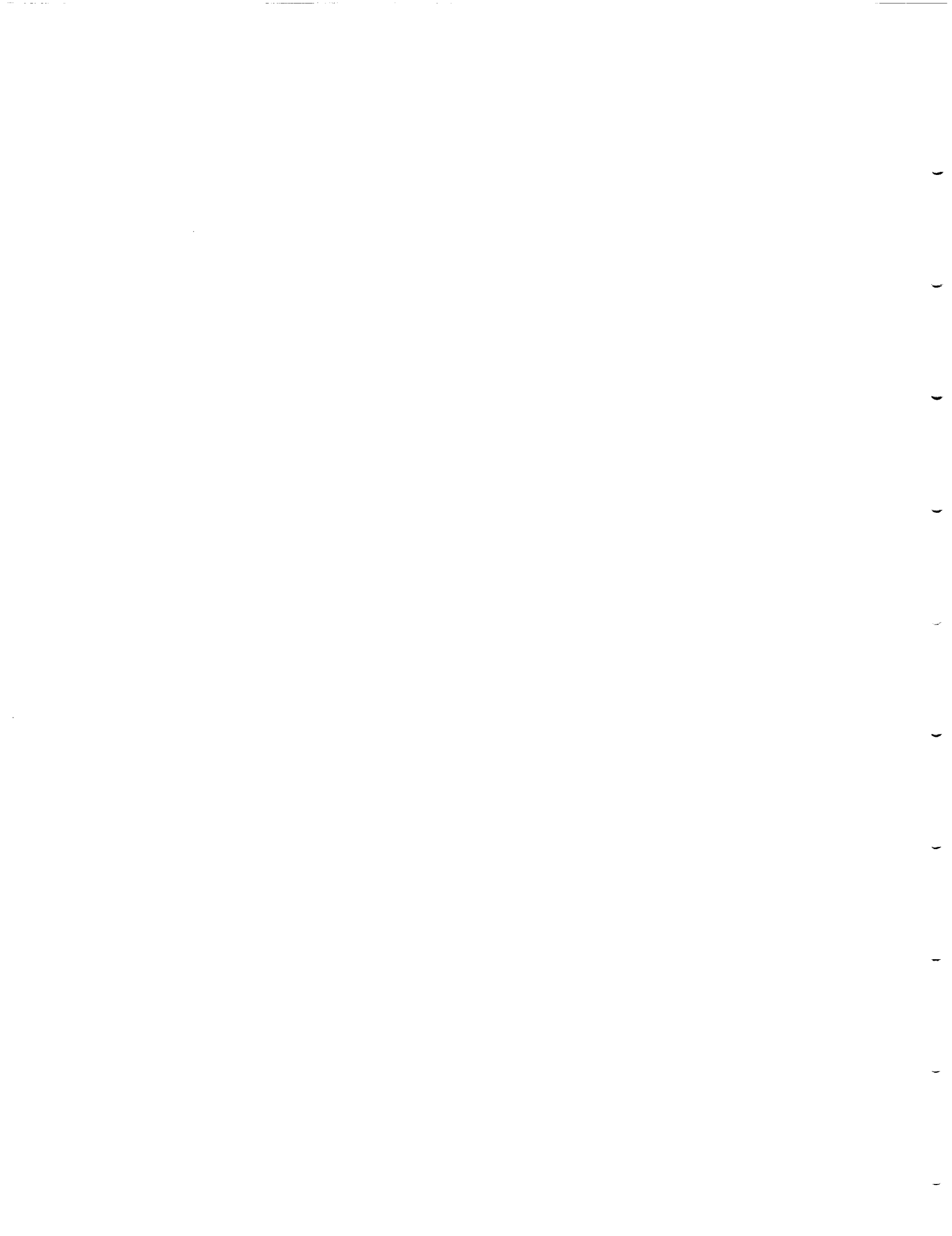

**NASA/GT**

AIRCRAFT NOISE ROUTE IMPACT ANALYSIS



# **SECTION 7**

**FEDERAL REGULATIONS  
AND  
ADVISORY CIRCULARS**

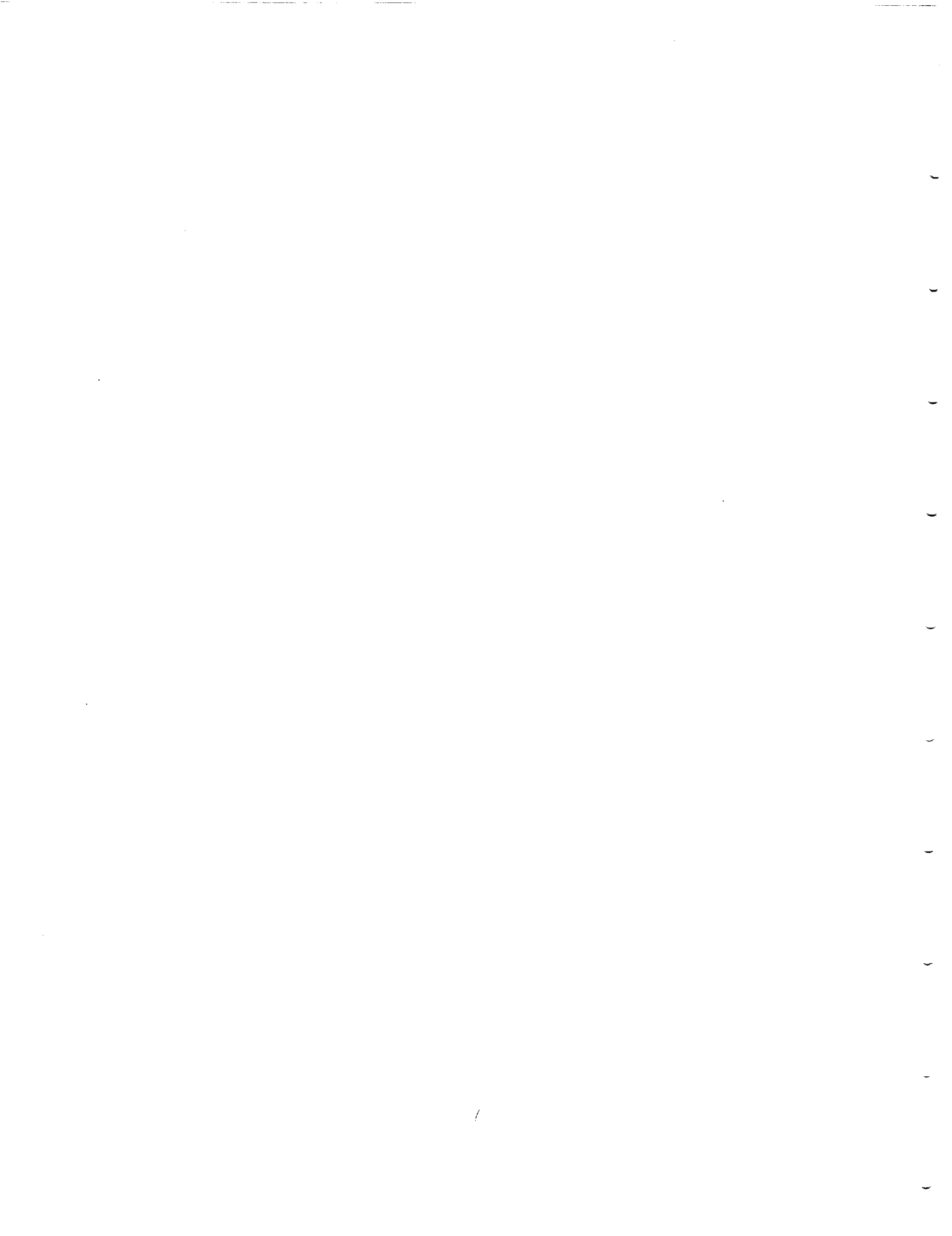

## 7.1 INTRODUCTION

### 7.1.1 Purpose

The purpose of this section is to inventory and review relevant federal regulations and advisory circulars that pertain to aircraft noise, route procedures and environmental land use compatibility. Included are Federal Advisory Regulation (FAR) Part 36, 77, 150, 161 (among others) and any data bases that may have been compiled relating to the application of these regulations and advisory circulars.

### 7.1.2 Background

All FAA regulations and advisory circulars pertaining to noise and aircraft related procedures and environmental land use compatibility were inventoried and reviewed. The details are given in subsection 7.2, which outlines methodology.

### 7.1.3 Interrelationship

Sections 3,5 and 6 relate most closely to federal regulations and advisory circulars since sound metrics, regulatory data bases, and airspace operational control measures apply directly to activities of the FAA. Data bases connected with land use, census and the environment reflect a moderate relationship since there are no FAA requirements that they be used. The FAA is becoming interested in GIS as a technology, but at this time it can be classified as minor relationship.

Table 7.1 Interrelationship of federal regulation and advisory circulars pertaining to route analysis and other sections.

<u>Section</u>	<u>Name</u>	<u>Level of Relationship</u>
2	Geographic information systems	R3
3	Sound metrics and descriptors	R1
4	Land use data bases	R2
5	Governmental regulatory data bases	R1
6	Airspace operational control measures	R1
8	Census, demographics, and real estate based analysis	R2
9	Environmental attributes	R2

- R1 - Major relationship
- R2 - Moderate Relationship
- R3 - Minor relationship
- R4 - No relationship

#### 7.1.4 Relevance

The Federal Aviation Administration (FAA) acts as the regulatory agency for the nation's airspace by formulating statutory federal regulations and advisory circulars that pertain to aircraft-related route procedures and environmental land use compatibility, among other responsibilities. Such documentation is extremely pertinent to any research initiative that addresses the routing of aircrafts through airspace and the associated impact of noise.

## 7.2 METHODOLOGY

### 7.2.1 General

In an effort to inventory and review all federal regulations and advisory circulars that pertain to this subject, the FAA was contacted by letter both at their headquarters in Washington, D.C., as well as the Southern Regional Office located in Atlanta, GA. These two offices were very cooperative in identifying the relevant documents and providing copies for this research project.

### 7.2.2 Specific

Eleven regulations and advisory circulars were collected and reviewed to assess their pertinence to aircraft-related route procedures and environmental land use compatibility. Several of these regulations included amendments and changes from the original date of publication. The regulations listed by Federal Aviation Regulation PART number and title are listed as follows:

**PART-36:**

Noise Standards: Aircraft Type and Airworthiness Certification  
(including changes 1 through 10, and 13 through 16).

**PART-71:**

Designation of Federal Airways, Area Low Routes, Controlled Airspace,  
and Reporting Points (including changes 1, 4, 5 and 6).

**PART-73:**

Special Use Airspace (including changes 1 through 3).

**Part-77:**

Objects Affecting Navigable Airspace.

**PART-91:**

General Operating and Flight Rules (consolidated reprint incorporating  
changes 1 through 10).



**PART-93:**  
Special Air Traffic Rules and Airport Traffic Patterns (consolidated reprint incorporating changes 1 through 21).

**PART-99:**  
Security Control of Air Traffic.

**PART-139:**  
Certification and Operations: Land Airports Serving Certain Air Carriers (consolidated reprint incorporating changes 1 through 3).

**PART-150:**  
Noise Control and Compatibility Planning for Airports.

**PART-159:**  
National Capital Airports (including changes 2 through 10).

**PART-161:**  
Final Rule Establishing a Program for Reviewing Airport Noise and Access Restrictions on the Operations of Stage 2 and Stage 3 Aircraft.

### 7.3 FINDINGS

Among the federal regulations and advisory circulars that were reviewed, the following were found to be the most pertinent to the overall study:

1. FAR PART-36
2. Advisory Circular PART-150
3. FAR PART-77
4. CFR Part-161

#### 7.3.1 FAR PART-36

Before any aircraft receives air worthiness certification it must be in compliance with specific noise standards. Once a particular aircraft type and series undergoes these noise measurement tests and meets these noise limits a noise certificate is issued. Upon issuing this certification all subsequent production aircraft of that type and series are also considered in compliance.

The FAR Part 36 includes several subparts that address:

1. Noise measurement and evaluation for transport category large airplanes and turbojet powered airplanes.

2. Noise limits for subsonic transport category large airplanes and subsonic turbojet powered airplanes.
3. Noise limits for supersonic transport category airplanes.
4. Noise limits for propeller driven small airplanes.
5. Operating limitations and information.

This particular Federal Aviation Regulation (FAR) also includes sections dealing with noise measurement, data collection and noise limits. These noise limits have been established for three stages of aircraft types: Stage 1, 2, and 3. Stage 3 represent the quietest technology aircraft (e.g. Boeing 767) while Stage 2 (e.g. Boeing 727) and Stage 1 (e.g. Boeing 707) are progressively noisier because of their earlier technological development. Efforts are being made to modernize the commercial air carrier fleet, based on economic feasibility, market demand, and FAA rule making (Airport Noise and Capacity Act of 1990). The basic objective is it to upgrade the aging fleet mix with the newer generation aircraft that are quieter and more energy efficient. In turn this will reduce the overall noise level of our commercial air carrier fleet. Part 161 (subsection 7.3.4) discusses these noise and access restrictions which are based on the stage of classification used in Part 36. Appendix K contains details of FAA Part 36 requirements.

### 7.3.2 Advisory Circular Part 150: Noise Control and Compatibility Planning For Airports

#### 7.3.2.1 Purpose

This advisory circular provides guidance for noise control and compatibility planning for airports under FAR Part 150 and the Aviation Safety and Noise Abatement Act of 1979 (ASNA) as amended. It is intended for use by airport operators, state/local planners and other officials, and interested citizens who may engage in noise control planning. Airport noise compatibility planning has the goals of reducing existing noncompatible land uses around airports and of preventing the introduction of additional noncompatible land uses through the cooperative efforts of all levels of government working in a public/private partnership. FAA Part 150 has the greatest potential of any federal program to encourage compatible planning in airport communities since the establishment of HUD's Section 701 planning program.

#### 7.3.2.2 Background

There are existing airport noise land use compatibility problems at many airports in the United States. In addition, there is a potential for exacerbation of present noise and land use incompatibilities and the possibility that new ones will occur at other airports as

air travel continues to grow. As a direct result of the Part 150 program there is increasing intergovernmental cooperation which is limiting the growth and distribution of noise. Actions have included limits upon noise emissions by new aircraft, provision for the retirement or retrofitting with quieter engines of the noisiest transport aircraft, and an environmental review process for airport development projects. Some of the major remaining obstacles for implementing successful noise compatibility programs around airports have been the need for a single system for measuring airport noise, a single system for determining the exposure of individuals to airport noise, the identification of land uses that are normally compatible with the various levels of noise around airports, and a process for safety and economic evaluations of proposed actions. These remaining major obstacles have been addressed by regulatory actions detailed below:

- a. FAR Part 150 implements portions of Title I of the ASNA. It specifically establishes a single system for the measurement of airport noise, a single system for determining the exposure of individuals to airport noise, and a standardized airport noise compatibility planning program. The planning program includes:
  1. provision for the development and submission to the FAA of Noise Exposure Maps (NEM) and Noise Compatibility Programs (NCP) by airport operators;
  2. standard noise units, methods and analytical techniques for use in airport assessments;
  3. identification of land uses that are normally compatible with various levels of noise around airports; and
  4. procedures and criteria for FAA approval or disapproval of noise compatibility programs by the administrator.
- b. The Airport Noise Compatibility Planning Program includes land use planning and implementation programs necessary to carry out the ASNA act. The act does not in any way, however, interfere with established prerogatives of state and local governments concerning land use and related noise compatibility actions and responsibilities. Accordingly, approvals and disapprovals of programs submitted to the FAA under Part 150 do not constitute a federal determination that the use of land covered by the program is acceptable or unacceptable under federal, state, or local law.

Nearly all the 200 airports that have participated in the program have also developed an NCP which reinforces the commitment to land use compatibility planning

at the local and regional level for noise control purposes.

### 7.3.2.3 Definitions

Several acoustical terms specifically discussed in this regulation are defined below. For further information and discussion refer to Section 3 - Sound Metrics, Descriptors, and Noise Prediction Programs.

a. **A-Weighted Sound Level (LA):**

The A-Weighted Sound Level is a sound pressure level which has been filtered or weighted to reduce the influence of the low and high frequency noise (formerly dBA).

b. **Compatible Land Use:**

Compatible land use is the use of land that is compatible with the outdoor noise environment at the location because the yearly day-night average sound level is at or below that identified for that particular use. The compatibility table (Appendix L) correlates noise exposure levels with the land use classification system. Although it is modified to suit the various needs of the local airport communities, this table is widely circulated and referenced by the professional planning community when political jurisdictions are developing or implementing a Noise Compatibility Plan (NCP).

c. **Yearly day-night average sound level (YDNL):**

YDNL is the 365 day average, in decibels, day-night average sound level. The abbreviation for YDNL is also  $L_{dn}$ .

d. **Day-Night Average Sound Level (DNL):**

DNL is the 24-hour average sound level, in decibels, for the period from midnight to midnight, obtained after the addition of ten decibels to sound levels for the periods between midnight and 7 a.m., and between 10 p.m., and 7 a.m.

e. **Noise Exposure Map (NEM):**

NEM is a scaled, geographic depiction of an airport, its noise contours, and surrounding area.

f. **Noncompatible Land use:**

Noncompatible Land Use is the use of land that is incompatible with the outdoor noise environment because the yearly day-night average sound level is above that

identified for that particular use (Appendix L).

#### 7.3.2.4 Noise Exposure Map Development, Noise Contours and Land Uses

- a. To determine the extent of the noise impact around an airport, airport proprietors developing noise exposure maps in accordance with this Part must develop DNL contours. Continuous contours must be developed for YDNL levels of 65, 70, and 75. In those areas where YDNL values are 65 YDNL or greater, the airport operator shall identify land uses and determine land use compatibility.
- b. Appendix M describes compatible land use information for several land uses as a function of YDNL values. These ranges of YDNL values reflect the statistical variability for the responses of large groups of people to noise. Any particular level might not, therefore, accurately assess an individual's perception of an active noise environment. Compatible or noncompatible land use is determined by comparing the predicted or measured YDNL values at a site with the values given.
- c. Compatibility designations (Appendix L) generally refer to the major use of the site. If other uses with greater sensitivity to noise are permitted by local government at a site, a determination of compatibility must be based on that use which is most adversely affected by noise. When appropriate, noise level reduction through incorporation of sound attenuation into the design and construction of a structure may be necessary to achieve compatibility.
- d. For the purpose of compliance with this Part, all land uses are considered to be compatible with noise levels less than Ldn 65 dB. Local needs or values may dictate further delineation based on local requirements or determinations.
- e. Except as provided in (f) below, the NEM must also contain and identify:
  - (i) Runway locations.
  - (ii) Flight tracks.
  - (iii) Noise Contours of Ldn 65, 70, and 75 dB resulting from aircraft operations.
  - (iv) Outline of the airport boundaries.
  - (v) Noncompatible land uses within the noise contours, including those within the Ldn 65 dB contours.

- (vi) Location of noise sensitive public buildings (such as schools, hospitals, and health care facilities), and properties on or eligible for inclusion in the National Register of historic Places.
  - (vii) Locations of any aircraft noise monitoring sites utilized for data acquisition and refinement procedures.
  - (viii) Estimates of the number of people residing within the Ldn 65, 70, and 75 dB contours.
  - (ix) Depiction of the required noise contours over a land use map of a sufficient scale and quality to discern streets and other identifiable geographic features.
- f. Notwithstanding any other provision of this Part, noise exposure maps prepared in connection with studies which were either federally funded or federally approved and which commenced before October 1, 1981, are not required to be modified to contain the following items:
- (i) Flight tracks depicted on the map.
  - (ii) Use of ambient noise to determine land use compatibility.
  - (iii) The Ldn 70 dB noise contour and data related to the Ldn 70 dB contour. When determinations on land use compatibility using Appendix L differ between Ldn 65-70 dB and the Ldn 70-75 dB, determinations should either use the more conservative Ldn 70-75 dB column or reflect determinations based on local needs and values.
  - (iv) Estimates of the number of people residing within the Ldn 65, 70, and 75 dB contours.

#### 7.3.2.5 Use of Computer Prediction Model

- a. The airport operator shall require the aviation operations data necessary to develop noise exposure contours using an FAA approved computer program, such as the Integrated Noise Model (INM) or NOISEMAP for airports. For details of NOISEMAP and INM 3.10 version refer to Section 3 (Sound Metrics, Descriptors and Noise Prediction Programs).
- b. The following information must be obtained for input to the calculation of noise exposure contours:

- (i) A map of the airport and its environs at an adequately detailed scale (not less than 1 inch to 8000 feet) indicating runway length, alignments, landing thresholds, takeoff start-of-roll points, airport boundary, and flight tracks.
  - (ii) Airport activity levels and operational data which will indicate, on an annual average daily basis, the number of aircraft, by type of aircraft, which utilizes each flight track in both the standard daytime (0700-2000 hours local) and nighttime (2200-0700 hours local) periods for both landings and takeoffs.
  - (iii) For landings, glide slopes, glide slope intercept altitudes, and other pertinent information needed to establish approach profiles along with the engine power levels needed to fly that approach profile.
  - (iv) For takeoffs the flight profile which is the relationship of altitude to distance from start-of-roll along with the engine power levels needed to fly that takeoff profile; these data must reflect the use of noise abatement departure procedures and, if applicable, the takeoff weight of the aircraft or some proxy for weight such as stage length.
  - (v) Existing topographical or airspace restrictions which preclude the utilization of alternative flight tracks.
  - (vi) The government furnished data depicting aircraft noise characteristics.
  - (vii) Airport elevation and average temperature.
- c. Accuracy: As is the case with any computer program, the accuracy of the output of INM is directly dependent upon the appropriateness, completeness, and accuracy of the input data. Input of average flight tracks, flight procedures, aircraft types and mix, and the schedules of operations can degrade the accuracy of the predicted contours. Further, the effects of local topography, weather, buildings, etc., cause acoustical variations from point to point along a contour. Accordingly, the accuracy of the INM computer noise prediction model in estimating the yearly average Ldn value at any specific geographical point has been estimated to be for the Ldn 75 contours  $-/+ 3$  dB and for the Ldn 65 contours  $-/+ 5$  dB, with the average error over all points along the contour tending towards zero. With each new model version, the accuracy in terms of prediction improves.

### 7.3.3 PART 77 - Objects Affecting Navigable Airspace

Safe navigable airspace is significantly influenced by land use development. Any structural obstacle that penetrates this airspace is tied to some type of development on the surface plane or ground. Consequently compatibility planning requires a three-dimensional analysis of both airspace and proposed development to insure there will be no possible physical conflicts. FAR PART 77 contains several characteristics described by scope, definitions and affected obstacles.

#### 7.3.3.1 Scope

- a. Establishes standards for determining obstructions in navigable airspace;
- b. Sets forth the requirements for notice to the Administrator of certain proposed construction or alteration;
- c. Provides for aeronautical studies of obstructions to air navigation, to determine their effect on the safe and efficient use of airspace;
- d. Provides for public hearings on the hazardous effects of proposed construction or alteration on air navigation; and
- e. Provides for establishing antenna farm areas.

#### 7.3.3.2 Definitions

Several terms that are pertinent to this regulation are given below.

- a. "A seaplane base" is considered to be an airport only if its sea lanes are outlined by visual markers.
- b. "Nonprecision instrument runway" means a runway having an existing instrument approach procedure utilizing air navigation facilities with only horizontal guidance, or area type navigation equipment, for which a straight-in nonprecision instrument approach, and for which no precision approach facilities are planned, or indicated on an FAA planning document or military service military airport planning document.
- c. "Precision instrument runway" means a runway having an existing instrument approach procedure utilizing an Instrument Landing System (ILS), or a Precision Approach Radar (PAR).
- d. "Utility runway" means a runway that is constructed for and intended to be



used by propeller-driven aircraft of 12,500 pounds maximum gross weight and less.

- e. "Visual runway" means a runway intended solely for the operation of aircraft using visual approach procedures, with no straight-in instrument approach procedure and no instrument designation indicated on an FAA approved airport layout plan.

#### 7.3.3.3 Kinds of Objects Affected

- a. Any object of natural growth, terrain, or permanent or temporary construction or alteration, including equipment or materials used therein, and apparatus of a permanent or temporary character; and
- b. Alteration of any permanent or temporary existing structure by a change in its height, or lateral dimensions, including equipment or materials used therein.

Appendix M contains PART 77 requirements in more complete detail.

#### 7.3.4 CFR PART-161

##### 7.3.4.1 Purpose

Part 161, which establishes a program for reviewing airport noise and access restrictions on operations of both Stage 2 and Stage 3 aircraft, has been issued, to implement the Airport Noise and Capacity Act of 1990. Several requirements and procedures associated with Part 161 are detailed below:

- a. Notice requirements and procedures for airport operators implementing stage 3 aircraft noise and access restrictions in accordance with agreements between airport and aircraft operators;
- b. Analysis and notice requirements for airport operators proposing stage 2 aircraft noise and access restrictions;
- c. Notice, review, and approval requirements for airport operators proposing stage 3 aircraft noise and access restrictions; and
- d. Procedures for Federal Aviation Administration reevaluation of agreements containing restrictions on stage 3 aircraft operations and of aircraft noise and access restrictions affecting stage 3 aircraft operations imposed by airport operators.

##### 7.3.4.2 Definitions

a. Agreement:

A document in writing signed by the airport operator; those aircraft operators currently operating at the airport that would be affected by the noise or access restriction; and all affected entrants planning to provide new air service within 180 days of the effective date of the restriction that have submitted to the airport operator a plan of operations and notice of agreement to the restriction.

b. Noise or Access Restrictions

Restrictions, including but not limited to provisions of ordinances and leases, affecting access or noise that affect the operations of stage 2 or stage 3 aircraft, such as limits on the noise generated on either a single-event or cumulative basis; a limit, direct or indirect, on the total number of stage 2 or stage 3 aircraft operations; a noise budget or noise allocation program that includes stage 2 or stage 3 aircraft; a restriction imposing limits on hours of operations; a program of airport-uses charges that has the direct or indirect effect of controlling airport noise; and any other limit on stage 2 or stage 3 aircraft that has the effect of controlling airport noise.

7.3.4.3 Notice of the Proposed Restriction

- a. An airport operator may not implement a stage 3 restriction in accordance with an agreement with all affected aircraft operators unless there has been public notice and an opportunity for comment.
- b. The airport operator must, at least 45 days before implementing the restriction, publish a notice of the proposed restriction in an area-wide newspaper and use a media which covers the airport noise study area; direct notification of the following parties must occur:
  1. Aircraft operators providing scheduled passenger or cargo service at the airport; affected operators of aircraft based at the airport; potential new entrants that are known interested in serving the airport; and aircraft operators known to routinely provide non-scheduled service;
  2. The Federal Aviation Administration
  3. Each federal, state, and local agency with land use control jurisdiction within the vicinity of the airport, or the airport noise study area
  4. Fixed-base operators and other airport tenants whose operations

may be affected by the proposed restriction; and

5. Community groups and business organizations that are known to be interested in the proposed restriction.

c. Each direct notice must include:

1. The name of the airport and associated cities and states;
2. Description of proposed restriction, sanctions for noncompliance, and a statement of the restriction's implementation in accordance with a signed agreement;
3. Discussion of need for and goal of the proposed restriction;
4. Identification of the affected parties
5. A proposed effective date and proposed enforcement mechanism
6. An invitation to comment on proposed restriction within a minimum of 45 days
7. Information on requesting copies of the restriction as well as additional information
8. A notice to potential new entrant aircraft operators of the requirements established for them
9. Information on submitting a new entrant application, comments, and identification of the appropriate contact person at the airport

d. The Federal Aviation Administration will publish an announcement of the proposed restriction in the Federal Register

#### 7.3.4.4 Required Analysis and Conditions for Approval of Proposed Restrictions

Each applicant proposing a noise or access restriction on operations must provide:

- a. The complete text of the proposed restriction and any submitted alternatives;
- b. Maps denoting the airport geographic boundary and the geographic boundaries and names of each jurisdiction that controls land use within the

airport noise study area;

- c. An adequate environmental assessment of the proposed restriction of adequate information supporting a categorical exclusion in accordance with FAA orders and procedures regarding compliance with the National Environmental Policy Act of 1969;
- d. A summary of the evidence in the submission supporting the six statutory conditions for approval;

The conditions for approval include:

- 1. The restriction is reasonable, nonarbitrary, and nondiscriminatory;
  - 2. The restriction does not create an undue burden on interstate or foreign commerce;
  - 3. The proposed restriction maintains safe and efficient use of the navigable airspace;
  - 4. The proposed restriction does not conflict with any existing Federal statute or regulation;
  - 5. The applicant has provided adequate opportunity for public comment on the proposed restriction; and
  - 6. The proposed restriction does not create an undue burden on the national aviation system.
- e. An analysis of the restriction, demonstrating by substantial evidence that the statutory conditions are met.

#### 7.4 CONCLUSION

Four FAA regulations and their appropriate advisory circulars were considered to be the most applicable to this research report. It appears that PART 77, 150 and 161 relate most closely to the routing of aircraft and the relationship to noise and safety. Land use compatibility planning is inexorably linked to all three of these aviation regulations either directly (i.e. PART 150) or indirectly (i.e. PART 77 and 161). There is a distinct role for local government through the use of police power to enact land use controls (e.g. zoning, etc.) for noise compatible development. At the same time these three federal regulations have an impact on local land use planning.

**NASA/GT**

AIRCRAFT NOISE ROUTE IMPACT ANALYSIS



# **SECTION 8**

**CENSUS, DEMOGRAPHICS  
AND  
REAL ESTATE DATA BASES**



## 8.1 INTRODUCTION

### 8.1.1 Purpose

The purpose of this section is to review the U.S. Census of Population, Housing, Business, and Manufacturing, and real estate data bases for specific attributes applicable to route impact analysis. Geo-economic information and demographic data from the U.S. Bureau of the Census for the entire United States as well as state and municipal political subdivisions are addressed. The study focuses on the usefulness of census-related data in the potential development and support of a three-dimensional aircraft routing model.

A primary subject area addressed in this section is the Topologically Integrated Geographic Encoding and Referencing (TIGER) system. The TIGER files are a digital data base which contain an automated description of selected physical attributes of the United States. These files comprise a computer-readable map and geographic data base for the entire United States [8.1,8.2]. When combined in a Geographic Information System (GIS), with digital census data, this resource can be used to access census data spatially.

### 8.1.2 Background

Mandated by Congress, the U.S. Census of Population and Housing is conducted on a decennial basis. The most recent Census of Population and Housing was conducted during April, 1990. Most of the 1990 census reports will be published by the end of 1993 [8.3 -8.5]. The census has many applications and is widely used by various entities such as federal agencies, state and local governments, business groups, demographers, and community organizations.

In 1989 the Census Bureau decided to build the TIGER system to produce improved maps for its census and survey. Prior to the 1990 census, the Bureau depended mostly on local sources to provide the base maps used by census enumerators. These maps came in many formats and were inconsistent in the features included. For the 1990 census, the Bureau consulted private sector GIS experts and joined forces with the United States Geological Survey (USGS) to develop a single integrated geographic data base for the entire nation. This geographic data base is known as the TIGER files.

### 8.1.3 Interrelationship

In assessing route impacts, spatial census data has numerous applications. For example, these data can be used to investigate population at risk relative to aircraft noise exposure level or to correlate sound level to housing values. Applications like these link census data and the TIGER files together.

Used within a GIS, the TIGER data base provides topologically integrated map

features that can be combined with census data and other data bases such as environmental and land use information. Therefore, census data and the TIGER files have a major relationship with GIS, Sound Metrics and Descriptors, Land Use Data Bases, and Environmental Attributes, and a moderate relationship with Government Regulatory Data Bases, Airspace Operational Control Measures, and Federal Regulations and Advisory Circulars. Table 8.1 shows the levels of interrelationship between this section and the other sections of this report.

Table 8.1 Interrelationship between census and other sections.

<u>Section</u>	<u>Name</u>	<u>Level of Relationship</u>
2	Geographic information systems	R1
3	Sound metrics and descriptors	R1
4	Land use data bases	R1
5	Government regulatory data base	R2
6	Airspace operational control measures	R2
7	Federal regulations and advisory circulars pertaining to route based analysis	R2
9	Environmental attributes	R1

R1 - Major relationship

R2 - Moderate Relationship

R3 - Minor relationship

R4 - No relationship

#### 8.1.4 Relevance

The use of U.S. Census data is essential to developing an aircraft routing system. Such data can be used to assess the potential impacts of any route from a locational perspective. The census data and the TIGER files can be used to spatially describe population distribution and to produce maps which display numerous demographic features for planning purposes.

## 8.2 METHODOLOGY

### 8.2.1 General

The research method used in this Section involved a detailed literature review of census information. Both the 1980 and 1990 decennial Census of Population and Housing and ancillary information (e.g. the TIGER files) were examined. Other related information, such as use of the real estate and property value data with GIS technology, was also examined.



## 8.2.2 Specific

A variety of techniques were used to acquire information for this section. Information concerning the U.S. Census, the TIGER files, and real estate data were obtained through library searches, correspondence, telephone inquiries requesting information, and materials collected at a national GIS conference (URISA, 1991).

## 8.3 FINDINGS

### 8.3.1 Overview of Data From the U.S. Bureau of the Census

The U.S. Bureau of the Census plays several roles. The primary roles include data collection and tabulation through censuses, surveys, and other programs. Supporting roles include acquiring and preparing maps used for data collection and publication, conducting surveys of political boundary changes, determining statistical area boundaries, and developing and maintaining automated geographic reference files [8.4]. The Bureau creates reference files with varying hierarchical geographic structures such as census tracts and urbanized areas.

Census data includes a wide range of subjects available in several forms. Data are available on the following subjects: General and Reference, Agriculture, Construction, Economic-General, Economic-Outlying Areas, Foreign Trade, Geography, Governments, Housing, International, Manufacturers, Mineral Industries, Population, Retail Trade, Service Industries, Transportation, and Wholesale Trade [8.4]. These data are available in the form of printed reports, microfiche, computer tape, computer floppy diskette, read-only compact disc (CD-ROM), and on-line information services.

Population, housing, geography, and economic-general data are most relevant to this project since they can be used to facilitate airport site planning, and noise abatement. The geo-economic, demographic, and housing information is essential in off airport site analysis for land acquisition and sound insulation programs.

Census data are organized according to a geographic hierarchy for tabulating and reporting statistics. Different levels of detail are reported in the census according to the level of geographical hierarchy [8.5]. The level of Census data available by geographical unit is shown in Figure 8.1 with the United States being the largest statistical geographic unit, and the block data is the smallest unit. A description for each of these geographical units is contained in Appendix N.

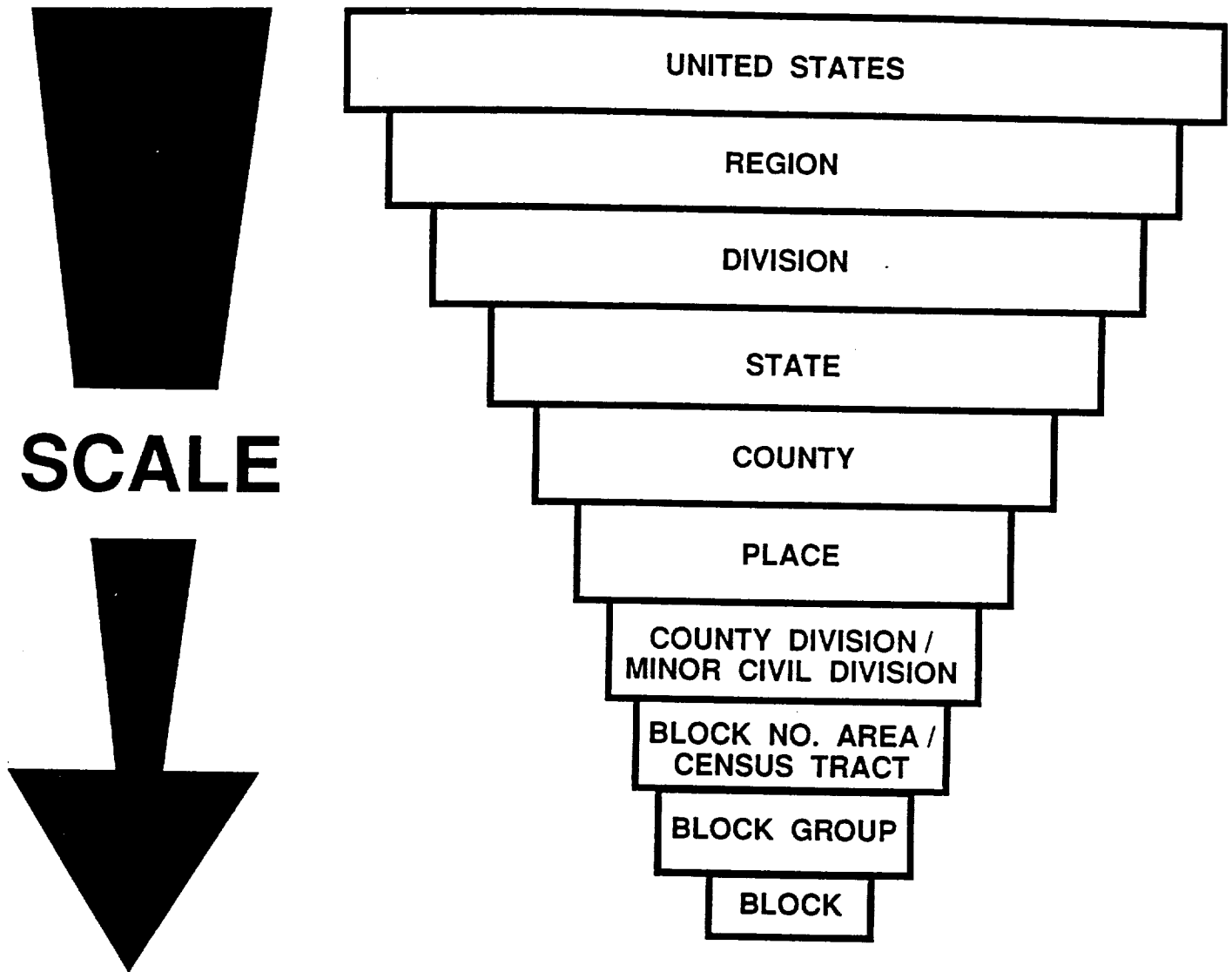

Figure 8.1 Geographic hierarchy of census data [8.5]

### 8.3.1.1 The Content of U.S. Census of Population and Housing

The 1990 Census of Population and Housing contains information on a broad range of topics, including total population counts, household relationships, sex, race, age, marital status, and ethnic origin [8.4,8.5]. These data are collected every ten years through the U.S. Bureau of the Census. The population and housing characteristics and counts covered in the 1990 census are contained in Appendix N. Corresponding information is provided for racial subcategories such as White, Black, American Indian, Eskimo or Aleut, Asian and Pacific Islander and for persons of Hispanic origin. Additional social and economic characteristics are provided for the entire U.S. population. The full breakdown of these characteristics is also presented in the same appendix. A full detail of these social and economic characteristics is not included at all hierarchical levels.

Population census data also contains social and economic characteristics. The subjects covered in the 1990 census are listed in Appendix N. The social characteristics of the population include education level, place of birth, ancestry, language spoken at home, migration, disability, fertility, and veteran status. Economic characteristics of the population include labor force, occupation, place of work, journey to work, work experience, income level and last year worked. Detailed economic data are reported from counties down through census tracts.

The 1990 housing data contains specific data related to housing. The following data categories covered include: number of units in structure, number of rooms in unit, number of occupants, tenure-owned or rented, value of home or monthly rent, congregate housing, and vacancy characteristics [8.5]. The primary characteristics covered in the 1990 census are listed in Appendix N. Detailed data are available for all levels in the geographic hierarchy, even to the block level. These data can be used with the TIGER files to derive other information such as the density of housing units or approximations of land value based on surrogate cost data.

### 8.3.1.2 List of 1990 Printed Census Reports

The Census Bureau is releasing the results of the 1990 Census to the public on a flow basis. This process began in 1991 and will continue through 1993 [8.4,8.5]. Printed reports will be published under the following subject titles:

- \* 1990 Census of Population and Housing (CPH)
- \* 1990 Census of Population (CP)
- \* 1990 Census of Housing (CH)

An overall listing of the printed reports planned for the 1990 census, described according

to the three major subject titles is contained in Appendix O.

### 8.3.1.3 Related Census Information

County Business Patterns are annual statistical reports that contain additional economic data organized by individual states [8.6]. This annual report provides detailed social and economic information including the number of employees, total payroll, and the number and employment size class. These data are listed and tabulated by state and county. The types of industries and major groups are categorized by individual standard code numbers referred to as Standard Industrial Classification (SIC) codes. The most current year available is 1989. County Business Patterns are available in a variety of formats including floppy diskettes, computer tapes and CD-ROM.

Business information can be very useful for this project. County Business Patterns data can be used to derive the economic patterns of the study regions, to identify the economic growth in the study areas, and to determine possible need for an airport. Airport sites can stimulate and reinforce the economic base of an area. Economic patterns, economic growth, and the trends of business patterns of the area could be studied so that the need for an airport and the present and future traffic demand can be identified and predicted.

Mandated by Congress, the U.S. Department of Housing and Urban Development (HUD) in cooperation with the Bureau of Census conducts a survey of housing, initially referred to as the Annual Housing Survey and subsequently as the American Housing Survey (AHS) [8.7]. The question of noise as an issue of environmental quality has been incorporated into the questionnaire, so that comparisons can be drawn between noise and other characteristics such as crime, air quality, street activity, and abandoned vehicles. Historically, noise has ranked as a primary reason why the population would relocate from their existing neighborhood. However, there is limited geographic data associated with the information. State and national AHS reports were last published in 1989. City level reports are also available for 1989. Although these reports provide useful ancillary information, no fixed frequency of publication has been set for the document.

### 8.3.2 Use of GIS in Real Estate

#### 8.3.2.1 Using GIS in Real Estate for Airport Site Analysis

GIS is useful for applications in real estate and airport site analysis. For example, this technology can be used to estimate the area of potential impacts for an airport site and to identify the attributes within that area. GIS can also be used to conduct spatial distribution mapping which is important in conducting an impact analysis. Another example of an application is creating environmental impact area maps from the airport site location and the associated noise contours. The noise contours can be used as polygons from which other information can be retrieved in order to define the magnitude

of conditions. These polygons, for example, could be used to extract the number of single family dwelling units, hospitals and other noise sensitive land uses from data bases stored in a GIS. Figure 8.2 is an example of the use of a GIS combining land use information with a set of annual average noise contours for Dekalb County, Georgia [2.2].

Studying airport site alternatives is another possible use of a GIS containing real estate data. Land values, property values, and locations relative to both existing and future airport noise contours can be analyzed. All of this data can be combined with other environmental information in a GIS format to develop a land acquisition program including the approximate costs in order to establish a phased budget [2.1, 3.8 and 8.8]. Appropriate land use management and land purchasing policies can also be studied in order to eliminate environmental impacts.

Other real estate applications of GIS involve the TIGER files. Combining census data with the TIGER files creates data bases that can be used to produce maps for metropolitan areas nationwide. Census data is related to the TIGER files through address data, as shown in Figure 8.3. This data could be used to show various attributes pertinent to real estate including residential land use, property value, and population density, housing, age, and condition. The attribute data can be graphically displayed using different patterns and colors that enable the GIS/Tiger File user to easily identify attribute characteristics on the display map. Depending upon the information desired as part of an aircraft noise route study these housing and population characteristics can be applied down to census block data.

**DEKALB CO.**  
**ATLANTA INTERNATIONAL**  
**AIRPORT NOISE STUDY**

- ESTATE RES
- LOW DENSITY RES
- L/M DENSITY RES
- MED DENSITY RES
- HI DENSITY RES
- MIXED USE
- INDUSTRIAL
- OFFICE/COMMERC
- QUARRIES
- INSTITUTIONAL
- OPEN SPACE



**FUTURE LAND  
 USE & 1990  
 NOISE CONTOURS**

Figure 8.2 Integration of future land use (1990) with projected noise contours (1990) in Dekalb County, Georgia [2.1]

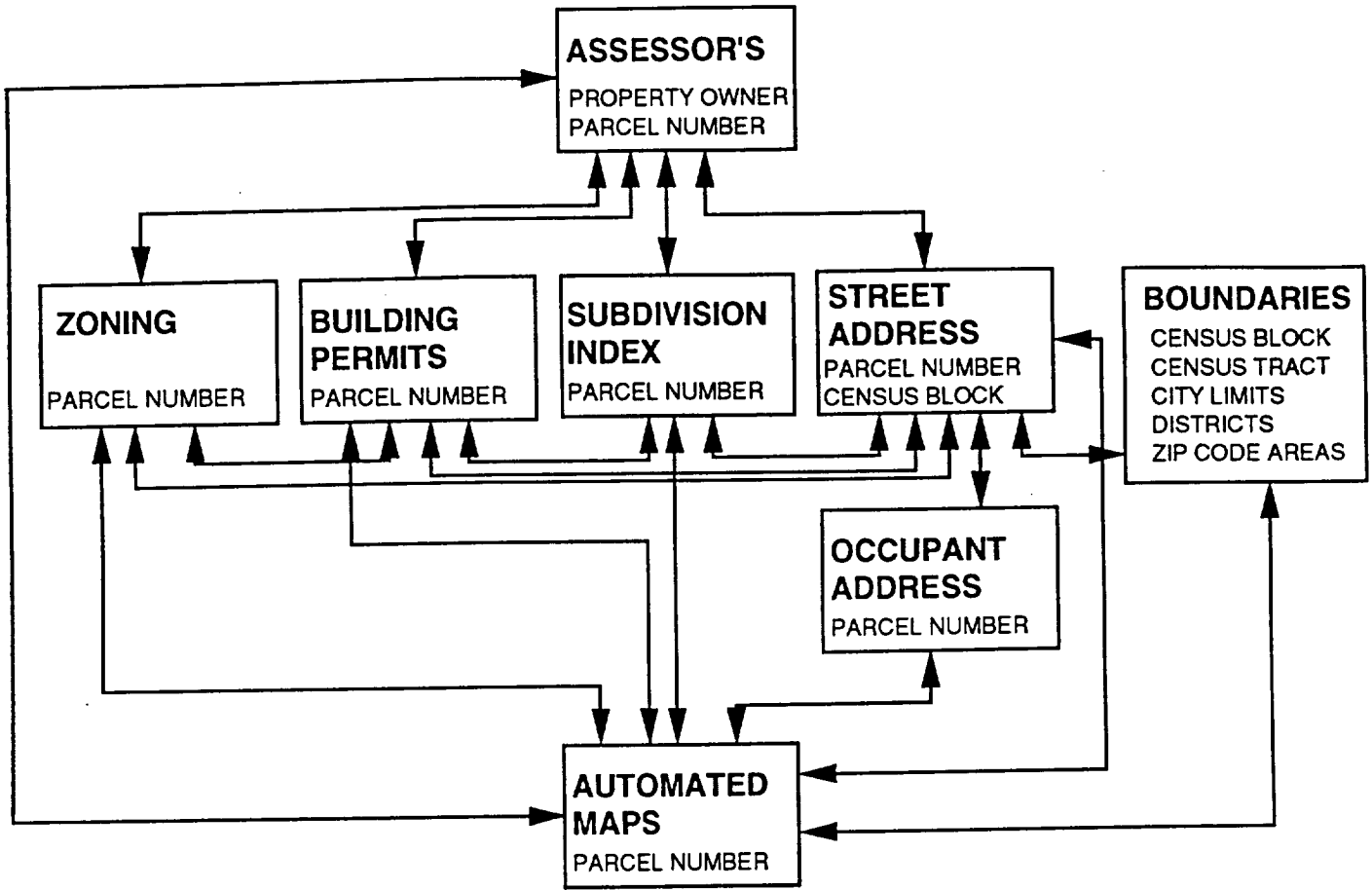

Figure 8.3 Flow chart showing file relations at a parcel based level [8.9]

### 8.3.2.3 Eliminating or Reducing Aircraft Noise in Residential Areas

A GIS using census data and the TIGER files can be used to eliminate or reduce aircraft noise in residential areas. Airport sites in undeveloped, non-residential areas are most desirable. However such land may not be always available, and it may not be cost effective to build an airport in an isolated area. When residential areas surrounding the desired airport site are already developed, purchasing the residential housing within the airport noise contour can reduce the noise impacts. A land purchasing policy such as this has been used in the development of the new Denver International Airport [8.9].

Another way to eliminate noise impacts on residential areas is through appropriate land use management [8.10]. A GIS could be used to study land use management alternatives. The original designated land use of parcels surrounding an airport site might be changed to other uses that could take better advantage of the infrastructure. Some areas near airports may not be suitable for residences but may be in high demand for other uses such as high technology research parks and large commercial malls, for example.

### 8.3.3 Geographic Data

A digital data base known as the Topologically Integrated Geographic Encoding and Referencing (TIGER) system could be useful in airport site analyses. TIGER, designed for use in computer mapping and GIS, contains an automated description of selected physical attributes of the United States [8.12]. This data base allows a user to topologically integrate map features with other demographic and economic data. The TIGER files can be used to generate maps such as transportation and hydrologic networks within a GIS.

#### 8.3.3.1 Overview of the TIGER Files

For the 1990 Census, the U.S. Bureau of the Census and the U.S. Geological Survey have jointly developed the TIGER system, a computer-readable map and geographic data base containing nearly every street in the United States [8.1 and 8.2]. The TIGER data base contains digital data of all 1990 census map features (such as roads, railroads, and rivers) and associated collection geography (such as census tracts and blocks), political areas (such as cities and townships), feature names and classification codes, alternative feature names, 1980 and 1990 census geographic area codes, FIPS (Federal Information Processing Standard) codes, and within metropolitan areas, address ranges and ZIP Codes for streets. Figure 8.4 presents a flow chart which can help potential TIGER/Line File users determine if the TIGER files are appropriate for their application.



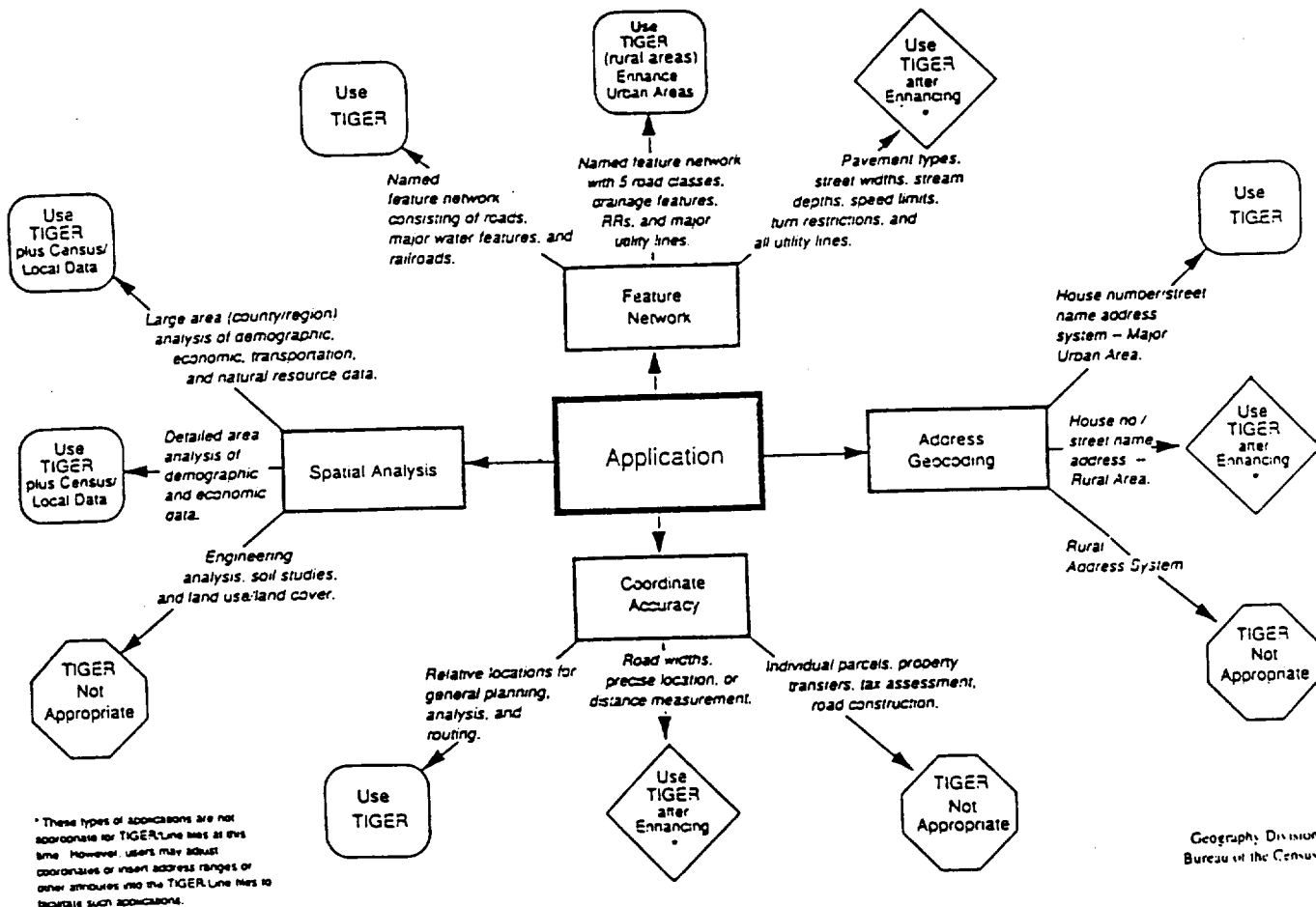

Figure 8.4 Flow chart for potential tiger/line file users [8.2]

A GIS allows a user to combine the geographic and cartographic data of the TIGER files with other demographic and socio-economic information such as population, housing, income, age, and travel behavior, etc., to create and display spatial distribution maps of these attributes. A user can select an area for analysis and automatically retrieve corresponding census data specified by census tracts and blocks, address ranges, and associated ZIP codes. The result is a powerful data base model suitable for thematic mapping; transportation and land use planning, routing and scheduling, market analysis, environmental impact assessment, pavement management, accident analysis, service district planning, site selection, political redistricting and many other applications. For example, with a TIGER-based GIS, government agencies can plot projected population growth derived from census data for analyzing and forecasting infrastructure and community needs in their jurisdiction. Public works departments can locate high accident intersections on a GIS. The map output could be used to prioritize improvements, schedule repairs for particular traffic signals, and designate specific intersections for geometric design improvements. Public utilities use GIS to locate utility lines and plan service for their customers. The physical location of public utility grids represents a precursor to residential development which in turn can be influenced by noise sensitive flight corridors.

#### 8.3.3.2 Significance of the TIGER System

The TIGER files are significant because they provide a computerized map data base to which census and other data can be associated. They contain detailed locational information about roads, census geography, and other features that describe census tracts and blocks. The essential characteristic of the TIGER files is that each area in the data base has been assigned the same FIPS code that is found in the census data associated with that area. With the census summary tapes, census statistics (attribute data) can be easily associated with the TIGER areas (cartographic data) through the FIPS code.

With a GIS linked to the TIGER files, analysis and study of census statistics can be done in any area specified by the user. Spatial relationships among attributes data can be studied by overlaying their corresponding maps.

Spatial relationships among population density, land use, economic growth, business patterns, real estate values, transportation systems, and other demographic and socio-economic information available from the Census Bureau can be studied in a GIS. Spatial distributions of various data can be created and displayed. With appropriate algorithms, an automated analysis can be developed in a GIS. By integrating census data with the TIGER system, analyses of airport site alternatives can be done in any area within specified boundaries, such as states, counties, census tracts and census blocks. Information pertaining to any land parcel can be retrieved for any region of interest specified by the user.

### 8.3.3.3 Conversion of the TIGER Files into a GIS Compatible Format

Once obtaining the TIGER files, they must be converted to a format used by a GIS. This format is dependent upon the application software, and different systems have their own programs for format conversion. There are a variety of software packages available which provide data conversion programs for files that can be in turn used for airport related communities or flight tracks involving community exposure.

## 8.4 CONCLUSION

### 8.4.1 Applicability

In this section, major categories of data produced by the U.S. Census Bureau have been reviewed. Among the census data, the demographic and socio-economic information is most useful to our project. Population data is important because it can be used to create a spatial distribution of population density for a particular area. These data can be displayed in a GIS conjugated with other maps derived from other data, such as land uses, current transportation systems, regional population growth and land values. Housing data can be used to determine residential density and its spatial distribution. Overlaying noise contours on Tiger Files with GIS technology provides analysts with the means to assess potential noise impacted areas.

According to the U.S. Census of Population and Housing, household income, property values, and monthly rents can be used to create the spatial distributions of real estate values. The economic data produced by the census bureau in the County Business Patterns can be used to derive the economic patterns of the study regions, to identify the economic growth of the study areas, and to determine the need for an airport. With a GIS, this information can be displayed as spatial maps, and the spatial relationships among all this information can be studied.

With the TIGER system, the current condition of a particular land parcel can be studied. The specific study region for an airport site or route analysis could be specified and then the noise impacts, environmental impacts, public safety concerns, and supportive transportation networks can be investigated. Census data organized in accordance to the TIGER file's geographic hierarchy can be used to extract the demographic and socio-economic information of any land parcel specified by the users and to display this information using a GIS.

### 8.4.2 Comprehensiveness

The coverage of the census data and TIGER files includes the entire United States. The relevant and useful census data for route analysis studies are population, housing and socio-economic data. The population and housing data are available for levels from states and counties down to census tracts and blocks. The socio-economic data is

available from counties down to towns and townships. This study included all known data bases containing census, demographic, and real estate information.

#### 8.4.3 Future

The development of national data bases containing census, demographic, and real estate is expected to continue in the future. The U.S. Bureau of the Census will continue to collect data as constitutionally mandated, and as the use of the TIGER files spreads more applications are likely to be developed for this digital data base, including their applicability to aircraft routing and airport community impact analysis and planning.

**NASA/GT**

AIRCRAFT NOISE ROUTE IMPACT ANALYSIS



# SECTION 9

**ENVIRONMENTAL  
ATTRIBUTES**

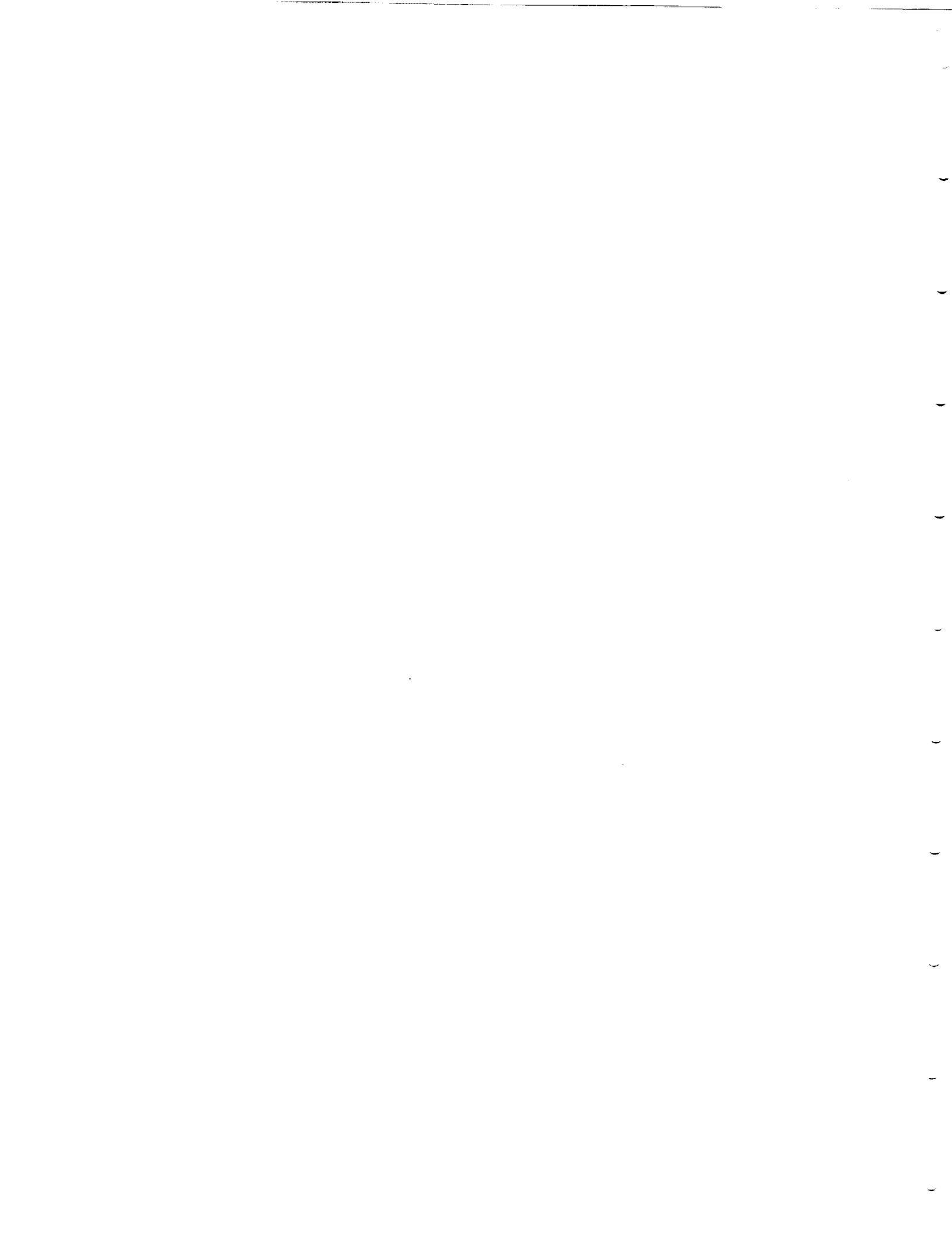

## 9.1 INTRODUCTION:

### 9.1.1 Purpose

The objective of this section is to identify and inventory all of the physiographic environmental features that are related to the environmental impact and assessment methodologies developed in response to the National Environmental Policy Act of 1969 and their applicability to airport location and aircraft route analysis. A detailed study of most environmental data bases available at the national level are attained within the appendices. Geographic information systems should be implemented in the early stages of the planning process for airport development and aircraft routing.

### 9.1.2 Background

The preservation of the natural environment is vital for human activity. There are portions of the environment that are particularly vulnerable to human development. Since the late sixties, the United States government has produced several laws protecting and maintaining certain resources vital to our environment. This study will document these laws and the data bases available to supplement the protection of these natural features. These laws include the Clean Air Act, the Clean Water Act, Endangered Species Act, National Historic Preservation Act, and the Coastal Barriers Act.

Aviation is an important transportation technology. Aircraft development and the efficient routing of aircraft is essential. Aircraft noise has become a prominent issue at all levels of government. Proper management and planning with an integrated three-dimensional route analysis tool will enable the aviation industry to proceed, minimizing a variety of environmental impacts to the physical and human environment.

This investigation will further highlight the concept of three-dimensional environmental planning for airport development and aircraft routing. From airport location and its influence on ground water supply to aircraft routing and the National Park Service's regulations on over-flights, three-dimensional planning includes traditional site planning as well as sub-surface and aerial planning. The integration of GIS into the planning and environmental impact assessment process will enhance the value of the output.

### 9.1.3 Interrelationship

Environmental attributes relate differently to the various sections within this report. All federal environmental laws and regulations affect the use of land and human development. Section 4 and Section 8 share information regarding data bases available for evaluation. Section 7 relates somewhat to the environmental attributes section because the federal regulations and advisory circulars pertaining to route analysis directly impact the same features in the natural environment. GIS (Section 2) will be the tool to

integrate environmental features into airport and aircraft route planning in the future and are directly related. The remaining section's relationships with environmental features vary. Section 3 (Sound Metrics) is evolving into the natural environment. The National Park Services is now developing a system that would document the impacts of noise on park populations. Sections 5 and 6 relate partially environmental attributes. Some regulations and airport operations affect the environment; yet, all of the laws do not relate directly to the environment. The following table describes the interrelationships between the environmental attributes section and the other sections performed in the project.

Table 9.1 Interrelationship between environmental attributes and other sections.

<u>Section</u>	<u>Name</u>	<u>Level of Relationship</u>
2	Geographic information systems	R1
3	Sound metrics and descriptors	R2
4	Land use data bases	R1
5	Government regulatory data base	R2
6	Airspace operational control measures	R2
7	Federal regulations and advisory circulars pertaining to route analysis	R2
8	Census, demographics and real estate based analysis	R1

- R1 - Major Relationship
- R2 - Relationship,
- R3 - Minor Relationship
- R4 - No Relationship

#### 9.1.4 Relevance

In 1969, the United States passed the National Environmental Policy Act, (NEPA). NEPA established the Council on Environmental Quality(CEQ) and required that specific environmental impact guidelines for government agencies to follow for federally funded projects be established. If federal funds are needed for a project to be completed the sponsor agency that is supervising the project must review that project's environmental impact statement(EIS). Copies of impact statements are sent to the Environmental Protection Agency and other agencies for review before the project can proceed. Figure 9.1 illustrates the EIS procedure. The Council on Environmental Quality designed the environmental impact statement as a planning tool to further understand the potential



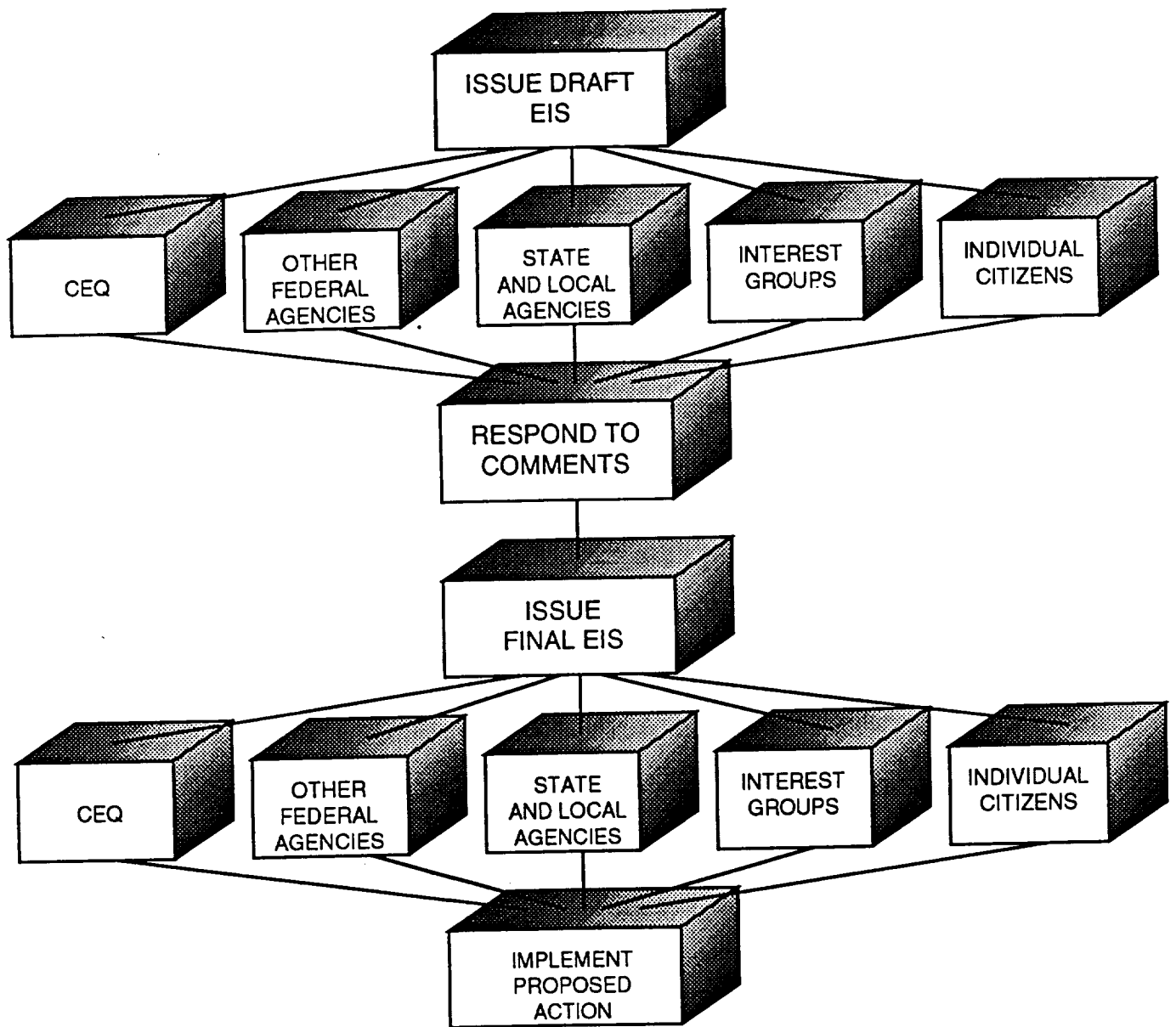

Figure 9.1. EIS procedures.

impacts, both positive and negative, of development sponsored by the federal government. This assessment and review process is required to occur before any money can be allocated by the federal government. The agency of the federal government that sponsors a type of development is required to approve the document and send it to the Environmental Protection Agency (EPA) for review, as well as to other agencies at the federal state and local levels. The information required in an EIS is illustrated in Figure 9.2. If the EIS is approved, then the government agency is allowed to assist funding the project.

The CEQ established regulations requiring the Department of Transportation's Federal Aviation Administration (FAA) to determine types of action subject to environmental assessments and procedures involving these actions related to air travel. The type of actions requiring an EIS are:

- 1) Approval of an Airport Location
- 2) Approval of an Airport layout plan or revisions to an airport layout plan
- 3) Approval of funding for airport development
- 4) Request for the conveyance of government land under Section 516 of the Airport and Airway Improvement Act of 1982
- 5) Request for new or revised air traffic control procedures which routinely route air traffic over noise sensitive areas less than 3,000 feet above ground level
- 6) Permission for special use airspace if the floor of the proposed area is below 3,000 feet above ground level or if supersonic flight is anticipated at any altitude [9.1].

The FAA produced the Airport Environmental Handbook in response to the NEPA requirements developed by the CEQ. This handbook outlines the steps and guidelines which are needed to produce a satisfactory EIS. The handbook provides guidance for airport personnel, airport sponsors, and others involved in airport actions, on the format and content of FAA environmental assessments and impact statements.

## 9.2 METHODOLOGY

### 9.2.1 General

The Airport Environmental Handbook, produced by the FAA on October 8, 1985, is the tool that will be used in determining and establishing all of the physiographic environmental features related to the environmental impact and assessment methodologies. The handbook includes information essential to meeting procedural and substantive environmental requirements established by the Council on Environmental Quality in its regulations implementing the National Environmental Policy Act. This FAA document provides guidance for the legal and administrative process needed to implement an airport development or expansion, including aircraft routing patterns.

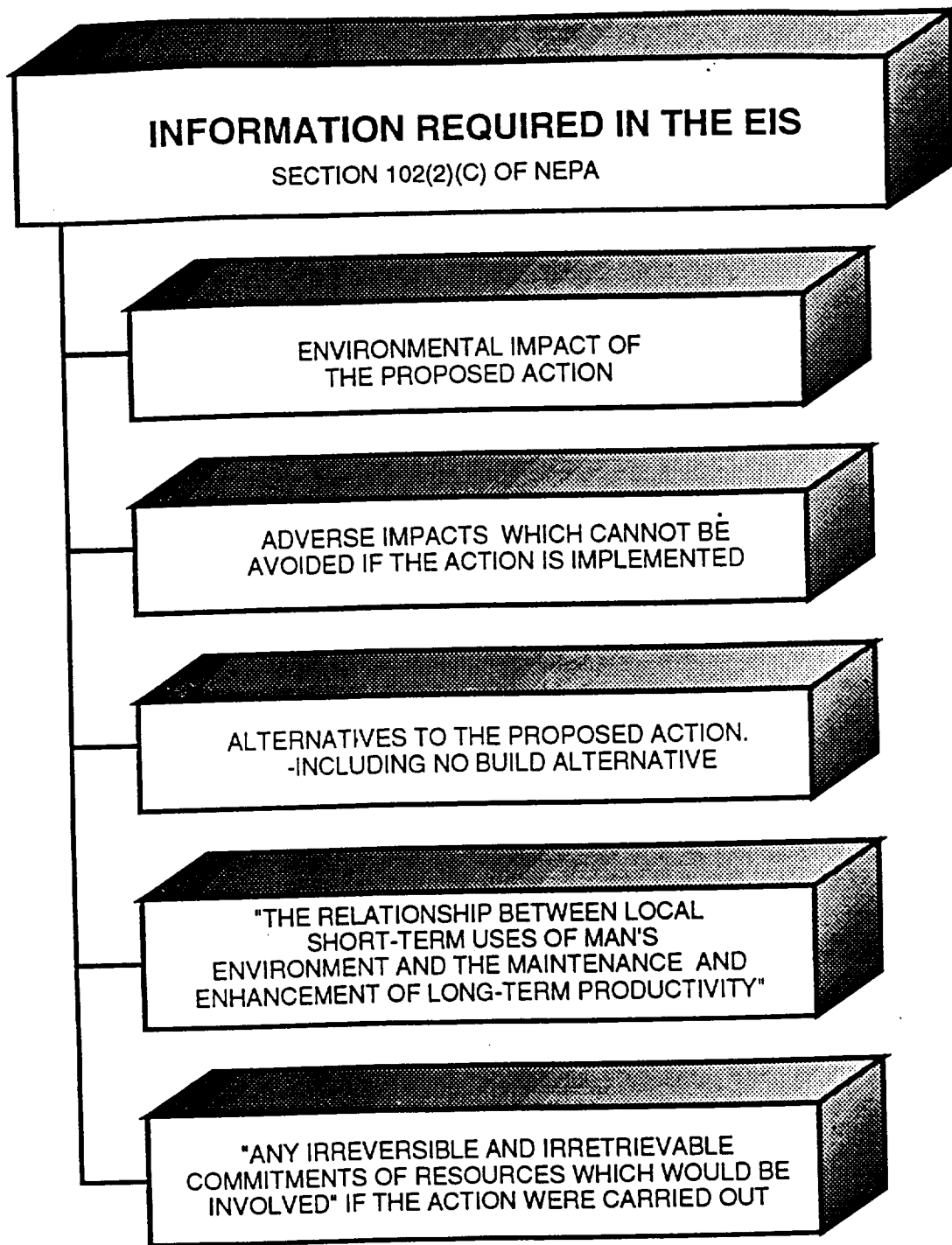

Figure 9.2 Required information in an EIS

### 9.2.2 Specific

After determining the procedure, the FAA requires for airport and air route development, specific government agencies were contacted because they maintain and collect the environmental features required to be reviewed by the FAA. These specific environmental features and the respective federal agencies required to be reviewed are:

- 1) Air Quality: U.S. EPA, U.S. National Oceanic & Atmospheric Administration
- 2) Water Quality: U.S. EPA, U.S. Geological Survey
- 3) Recreation Lands: U.S. National Park Service
- 4) Historic, Architectural, Archeological, and Cultural: U.S. National Park Service
- 5) Endangered and Threatened Species: U.S. Fish and Wildlife Service, Nature Conservancy
- 6) Wetlands: U.S. Fish and Wildlife Service
- 7) Flood Plains: U.S. Federal Emergency Management Agency
- 8) Coastal Barriers: U.S. National Park Service, U.S. Fish and Wildlife Service
- 9) Wild and Scenic Rivers: U.S. National Park Service.

Numerous interviews were conducted in order to obtain detailed information regarding the status of federal data bases for each of these nine environmental features. Similar inquiries were made at regional levels in order to determine the status of selected state-wide data bases. A literature review on the various environmental features and GIS capabilities with these features was also conducted.

The next section of the analysis will document the various federal laws and regulations pertaining to the over-flight of the natural environment and the nine specific features stated in the Environmental Handbook earlier. Each feature section will contain the data bases currently available to the public. Figure 9.3 illustrates the procedure followed for each environmental attribute.

### 9.3 FINDINGS

The section will identify, inventory, characterize and analyze the various environmental data bases that should be considered for airport and air route development.

The Handbook mentioned above identifies nine specific environmental features that must be examined in the EIS process and thus must be included in airport and aircraft route analysis.

In addition to the Airport Environmental Handbook, the FAA has some specific requirements, regulations and advisory circulars pertaining to aircraft routing and physiographic environmental features in the United States.

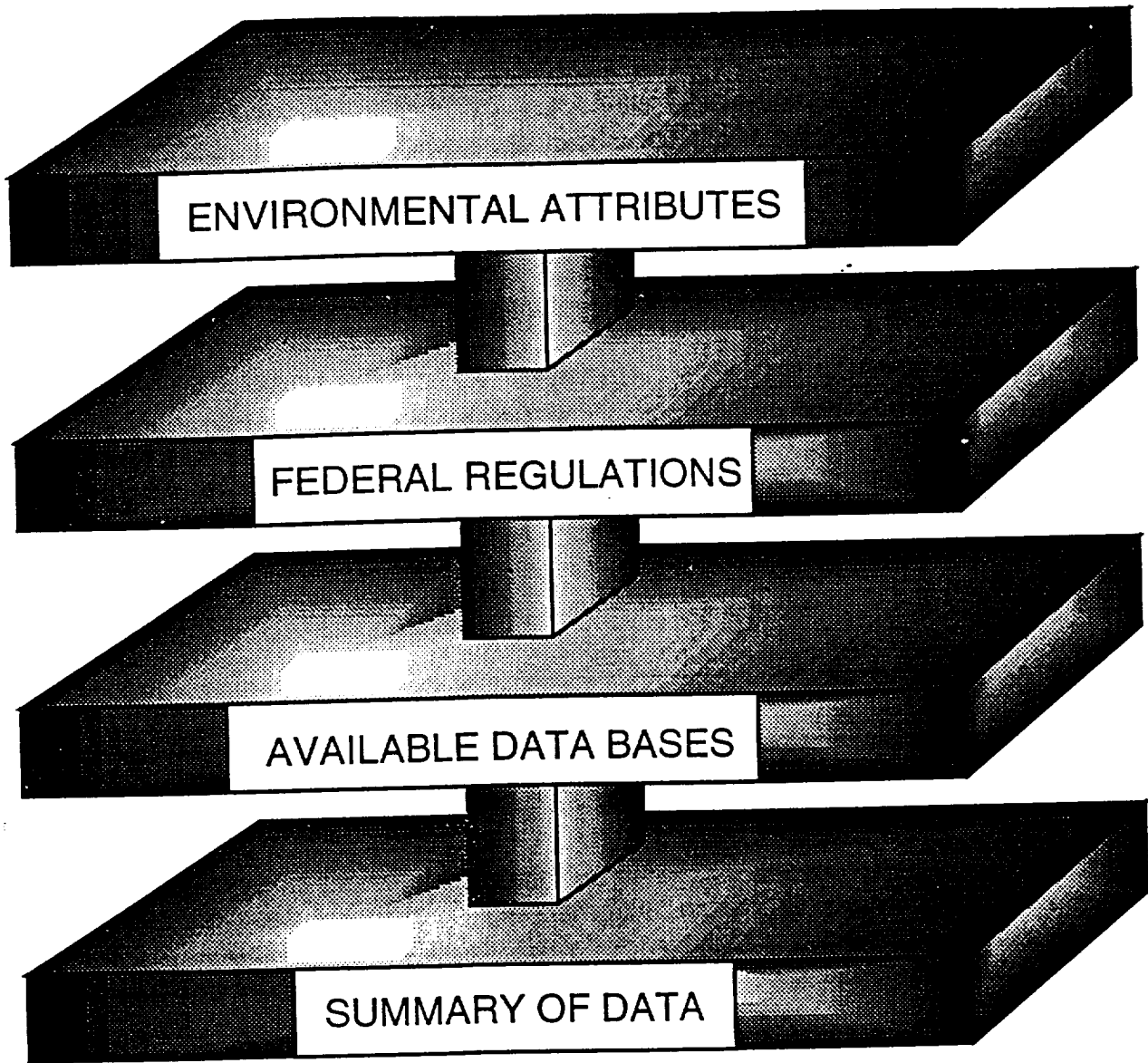

Figure 9.3 Research procedure

### 9.3.1 Federal Flight Restrictions

In 1987 Congress passed Public Law 100-91, which placed restrictions on aircraft over-flights at three National Parks. These parks are the Grand Canyon National Park in Arizona, Yosemite National Park in California, and Haleakala National Park in Hawaii. The law requires the FAA to impose flight restrictions at these parks to "...provide for the substantial restoration of the natural quiet and experience of the parks and protection of public health and safety from adverse effects associated with aircraft over-flights." [9.1] The FAA designed these restrictions to include flight free zones that encompass approximately 530,000 acres or 44% of the Grand Canyon Park. In addition, Congress required the FAA to prepare an advisory circular restricting overflights at Mount Rushmore National Memorial. The restrictions and advisory circulars require flight free districts 2,000 feet above the highest elevation at each of the four national parks.

Included with the restrictions, Congress required the National Park Service to conduct studies of noise impacts at these parks for the possibility of establishing permanent flight free zones at all of the National Parks in the United States. Currently the National Park Service is conducting these required studies, in order to determine the effects of aircraft over-flights on park users. The results from the noise studies will be available to the public by 1993.

### 9.3.2 Air Quality

#### 9.3.2.1 Regulatory Process

In the sixties the government started to realize that it would have to protect its citizen from air pollution. Laws were passed and amended to regulate the ambient quality of air; and to control the output of polluting gases. Section 176(c) of the Clean Air Act Amendments of 1977 states in part "that no Federal agency shall engage in, support in any way or provide financial assistance for, license or permit, or approve any activity which does not conform to a State Implementation Plan after it has been approved or promulgated under section 110 of that act" [9.2]. It is the FAA's responsibility to assure that Federal airport actions conform to state plans for controlling area wide air pollution impacts [9.2].

If Federal action involves airport location, runway development or other physical air-side and/or land-side improvements increase airport capacity an air quality analysis is required. The procedures for such an analysis are adopted from the handbook, "Air Quality Procedures for Civilian Airports and Air Force Bases," report # FAA-EE-82-21" [9.2].

Other types of airport projects generally do not require air quality analysis for the environmental assessment. It can be assumed that there will be no potential for significant air quality impacts [9.2]. There may be exceptions which occur very

infrequently that require FAA judgement on a case-by-case basis of how much air quality information is needed [9.2]. The available databases and summary of data information can be found in Appendix P.

### 9.3.3 Water Quality

#### 9.3.3.1 Regulatory Process

Water quality has been a concern of the United States government since the turn of the century. Yet, specific legislation protecting water quality was not passed until 1965. The Federal Water Pollution Control Act, as amended by the Clean Water Act of 1977 provides the authority to establish water quality standards, control discharges into surface and subsurface waters, develop waste treatment management plans and practices, and issue permits for discharges (section 402) and for dredged or fill material (section 404). "The Environmental assessment shall include sufficient description of design, mitigation measure, and construction controls applicable to the proposal to demonstrate that state water quality standards and any federal, state, and local permit requirements can be met. Such factors as storm and sanitary sewer design, requirements for additional water supplies, waste treatment capacity, erosion controls to prevent siltation, provisions for containing fuel spills and waste water from aircraft washing, designs to preserve existing drainage or to minimize dredge and fill, locations with regard to an aquifer or sensitive ecological area such as wetlands area be considered to the extent applicable to the individuals proposal" [9.2]. Due to the large paved areas associated with the runway, taxi, and apron areas, runoff represents a major potential problem for airports.

The FAA requires early consultation with local, state, and federal agencies in charge of implementation of water quality regulations and issuance of permits. These informational meetings will normally identify any deficiencies in the proposal with regard to water quality [9.2].

A water quality certification is required under the 1982 Airport Act for approval of an Airport Improvement Program application for a project involving airport location, a major runway extension, or a runway location [9.2].

Consultation with the EPA regional office is required if there is the potential for contamination of an aquifer designated by the EPA as a sole or principal drinking water resource for the area pursuant to the section 1424(e) of the Safe Drinking Water Act.

Section 402 of the Clean water act requires A national pollutant discharge elimination system permit for discharges into navigable waters. A Section 10 permit under the Rivers and Harbors Act of 1899 is required for obstruction or alteration of navigable waters [9.2].

An environmental impact statement may be required if the environmental

assessment and early consultation show the potential for exceeding water quality standards. Identification of water quality problems which cannot be avoided or satisfactorily mitigated must be documented [9.2]. The available data bases and a summary of data information can be found in Appendix Q.

#### 9.3.4 Recreation Land

##### 9.3.4.1 Regulatory Process

Large amounts of public funds are used to finance transportation systems. Public funds should not be used to take away or destroy areas already being preserved or protected from development by federal programs. Department of Transportation Act section 4(f) states "that the secretary shall not approve any program or project which requires the use of any publicly owned lands, from a public park, recreation area, or wildlife and waterfowl refuge of national, state, or local significance as determined by the officials having jurisdiction thereof unless there is a feasible and prudent alternative to the use of such land and such program or project includes all possible planning to minimize harm resulting from airport construction, or fly-overs at altitudes under 3,000 ft., or at supersonic speeds.

The environmental assessment procedures should include evidence of contact with appropriate grantor agencies if Federal grant money was used to acquire the land involved (i.e., open space under H.U.D., various conservation programs under D.O.I.) before the project can proceed [9.1]. The available data bases and a summary of data information can be found in Appendix R.

#### 9.3.5 Historic, Architectural, Archeological, Cultural Resources

##### 9.3.5.1 Regulatory Process

The nation's cultural and historical landmarks are preserved by two basic laws; the National Historic Preservation Act of 1966, and the Archeological and Historic Preservation Act of 1974. Thresholds concerning both of these laws must be examined in the environmental assessment.

The first law is the National Historic Preservation Act of 1966, specifically Section 106, which establishes the Advisory Council on Historic Preservation to advise the President and the Congress on historic preservation matters, to recommend measures to coordinate Federal historic preservation actions affecting properties included in or eligible for inclusion in the National Register of Historic Places [9.3]. The Advisory Council's most recent procedures for the "Protection of Historic and Cultural Properties" (36 CFR Part 800) were published in the Federal Register on January 30, 1979.

The second law is the Archeological and Historic Preservation Act of 1974 which



provides for the survey, recovery, and preservation of significant scientific, prehistorical, historic, archeological, or paleontological data when such data may be destroyed or irreparably lost due to a federally licensed, or federally funded project [9.2].

An initial review shall be made to determine if any properties in, or eligible for inclusion in, the National Register of Historic Places are within the area of the proposed action's potential environmental impact. This area is the geographic area within which direct and indirect impacts generated by the proposed action could reasonably be expected to occur and thus cause a change in the historic, architectural, archeological, or cultural qualities possessed by the property. The National Register criteria shall be applied to all such identified properties [9.3].

To aid in identifying properties, the National Park Service maintains the National Register data base and publishes a list of new entries once a year in the Federal Register. This data base is spatially referenced using the Universal Transverse Mercator coordinate system of the North American Datum of 1927. In addition, the state Historic Preservation Officer must be consulted for advice. Most of the fifty states maintain an extensive survey of eligible sites for the National Register. These data bases are often more extensive than the National Park Service's data base of eligible sites. Currently the National Survey of Eligible Sites contains 11,000 sites, while the State of Georgia alone has a data base of over 6,500 sites [9.6 and 9.7].

If any property eligible for the National Register has been identified within the area of the proposed action's environmental impact, the Advisory Council on Historic Preservation Procedures for the Protection of Historic and Cultural Properties shall be used to determine if the proposed action will have any effect on the property. Initially the criteria of effect (36 CFR Part 800) shall be applied in consultation with the State Historic Preservation Officer [9.3]. The procedural process is shown in Figure 9.4. The available data bases and a summary of data information can be found in Appendix S.

### 9.3.6 Endangered and threatened Species of Flora and Fauna

Americans have become aware that land development can impact or even destroy the habitats of many valued animals including our national symbol, the Bald Eagle Figure 9.5. Section 7 of the Endangered Species Act as amended requires each federal agency to insure that "any action authorized, funded, or carried out by such agency...is not likely to jeopardize the continued existence of any endangered or threatened species or result in the destruction or adverse modification of habitat of such species which is determined by the Fish and Wildlife Service, after consultation as appropriate with the affected states" [9.2]. Further, Section 7a(3) requires that "each Federal agency shall confer with the Secretary of the Interior on any species proposed to be listed under section 4 or results in the destruction or adverse modification of critical habitat proposed to be designated for such species" [9.2].

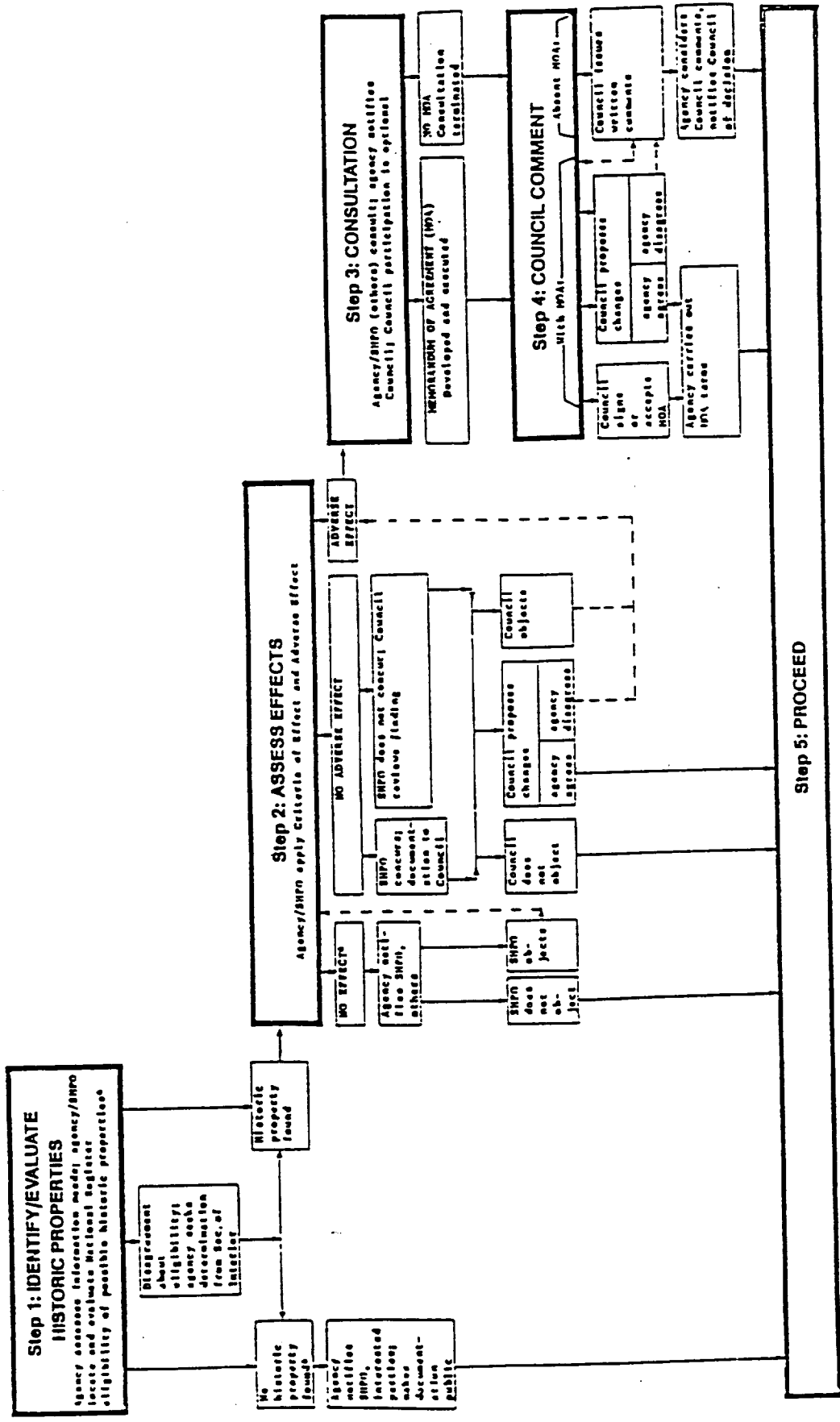

Figure 9.4 The basic steps of section 106 review.

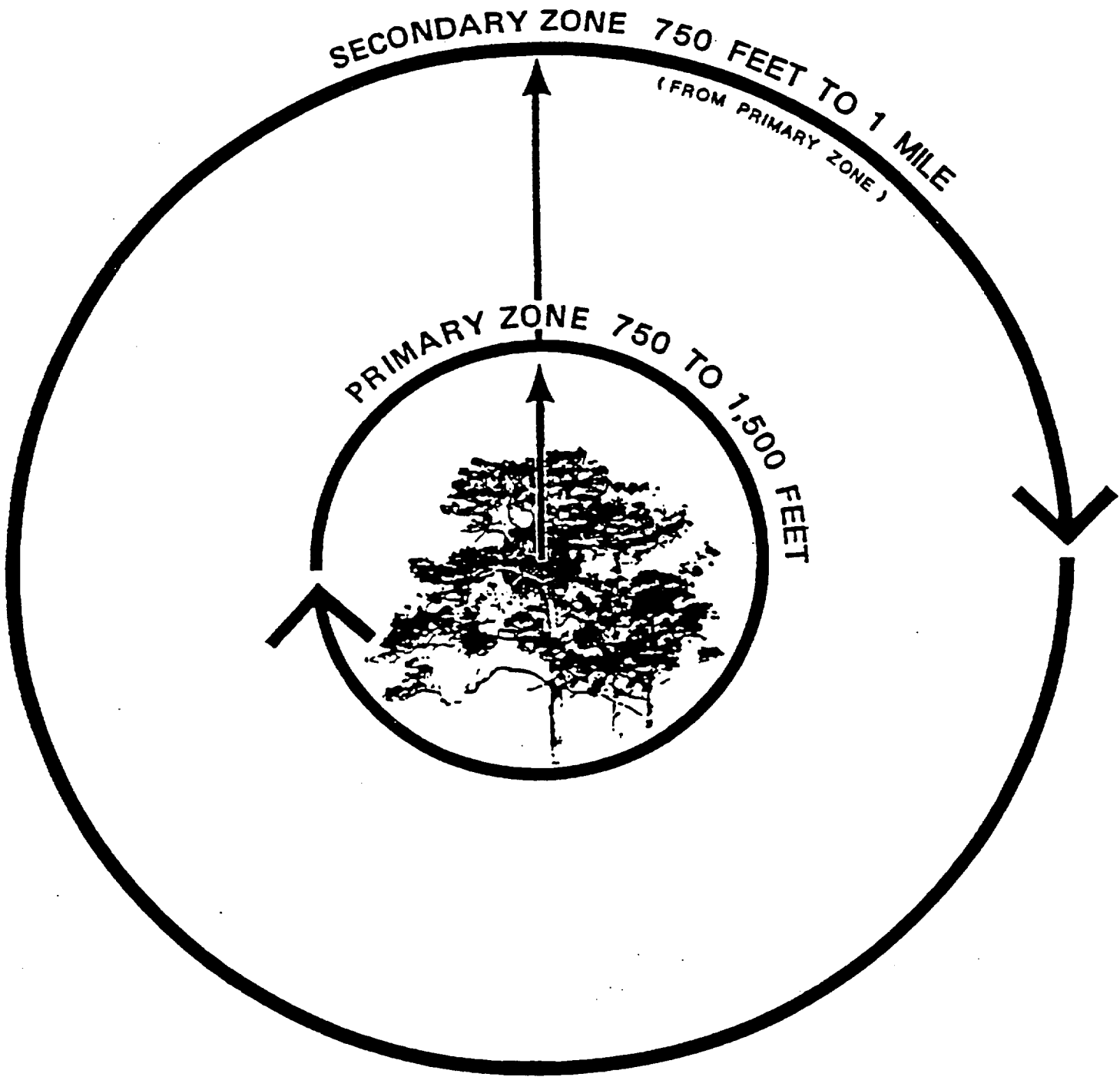

Figure 9.5 Bald eagle colony buffer requirements [9.4].

The Fish and Wildlife Service and the National Marine Fisheries Service define a construction project as "any major federal action designed primarily to result in the building of man made structures and which significantly affects the quality of the human environment. This includes federal actions such as permits, grants, licenses, and other forms of federal authorization or approval which might result in construction" [9.2].

Section 7(c) of the Endangered Species Act as amended information shall be requested by the FAA or by the sponsor on behalf of the FAA from the Fish and Wildlife Service or the National Marine Fisheries Service on whether any species which is listed or proposed to be listed may be present in the area affected by the proposed action [9.2].

If there is an indication that an endangered or threatened species may be present in the area affected by the proposed action, a biological assessment shall be prepared to identify whether the species or critical habitat are likely to be affected by the action and what those effects would be. The available data bases and a summary of data information can be found in Appendix T.

### 9.3.7 Wetlands

Wetlands are the heart of the natural environment. More life is supported around or near wetlands than most other natural features in the country. Wetlands are protected and defined in Executive Order 11990, as "those areas that are inundated by surface or ground water with a frequency sufficient to support and under normal circumstances does or would support a prevalence of vegetative or aquatic life that requires saturated or seasonally saturated soil conditions for growth and reproduction" [9.2]. Although the precise application of wetlands terminology continues to change, wetlands generally includes swamps, marshes, bogs, and similar areas such as sloughs, potholes, wet meadows, river overflows, and shallow lakes and ponds with emergent vegetation. Adjacent uplands or regions upstream and downstream from wetlands are areas covered with water for such a short time that there is no effect on moist soil vegetation are not included with in the definition of wetlands nor are the permanent waters of streams, reservoirs, and deep lakes [9.2]. The importance of wetlands to the Nation is reemphasized in Executive Order 11990, issued May 24, 1977. The Executive Order provides that "federal agencies: 1) avoid to the extent possible the long and short term adverse impacts associated with the destruction or modification of wetlands and to avoid direct or indirect support of new construction in wetlands wherever there is a practicable alternative. 2) avoid undertaking or providing assistance for new construction located in wetlands unless the head of the agency finds that there is no feasible alternative to such construction, and that the proposed action includes all practicable measures to minimize harm to wetlands which may result from such use" [9.2].

A construction project is considered to affect wetlands if it would involve development in a wetland area. Such action would involve dredging, filling, draining,

channelizing, diking, impounding, or otherwise directly impact a wetlands area. Also, the process would involve disturbing the water table of an area in which a wetlands lies; or, indirectly affect a wetland by impacting regions upstream or downstream or inducing secondary development [9.2]. If there is uncertainty about whether an area is a wetland, the U.S. Fish and Wildlife Service or the local or state natural resource agency shall be contacted for further information.

At this time the Executive Branch of the federal government is considering changing the definition of wetlands. The requirements and regulations that were established with Executive Order 11990 would not be altered; however, the physical characteristics of the wetlands definition would be changed to reduce the acreage available for protection by E.O. 11990. An executive appointed committee is currently reviewing public responses to the proposed definition change. Based on the public response, the President can change the definition of wetlands, thereby reducing the protected areas by as much as thirty percent [9.5]. The available national wetlands data bases and a summary of data information can be found in Appendix U.

### 9.3.8 Floodplains

Rivers and streams have played an important role in the history of our society. Water's multiple uses make it our most important commodity. Flooding, however, annually costs the country millions of dollars and the tragic loss of life. Governments at all levels are discouraging certain activities on the floodplains. Floodplains defined in Executive Order 11988 as "lowland and relatively flat areas adjoining inland and coastal waters including flood prone areas of offshore islands, including at a minimum, that area subject to a one percent chance of flooding in any given year" (i.e., the area that would be inundated by a 100-year flood) [9.2].

Executive Order 11988 directs Federal agencies to "take action to reduce the risk of flood loss, to minimize the impacts of floods on human safety, health and welfare, and to restore and preserve the natural and beneficial values served by flood plains..." [9.2]. Implementation of the DOT's policies and procedures are contained in DOT Order 5650.2, Floodplain Management and Protection [9.2]. The beneficial value served by floodplains are defined by the DOT include, "natural moderation of floods, water quality maintenance, ground water recharge, fish, wildlife, plants, open space, natural beauty, scientific study, outdoor recreation, agriculture, aquaculture, and forestry [9.2]. Executive order 11988 and DOT order 5650.2 establish policy to avoid taking an action within a 100-year floodplain where feasible. Every effort must be made to minimize the potential risks to human safety and property damage and the adverse impacts on natural and beneficial floodplain values. If a 100-year flood map is in question, then the Federal Insurance Administration (FIA) or the Corps of Engineers shall be contacted for information [9.2]. The available data bases and a summary of data information can be found in Appendix V.

### 9.3.9 Coastal Barriers

Coastal barriers are vital to the natural balance and protection of coast lines. The Coastal Barriers Resources Act of 1982, PL 97-348, (CBRA), "prohibits, with some exceptions, Federal financial assistance for development within The Coastal Barriers Resource System which consists of undeveloped coastal barriers along the Atlantic and Gulf coasts" [9.2]. Maps identifying lands included in this system are available for inspection in the Fish and Wildlife Service offices. The Department of the Interior issued CBRA Advisory Guidelines (43CFR Subtitle A, reference 48 FR 45664). New financial assistance for specific types of construction or purchase, including airports is prohibited by the C.B.R.A.. [9.2]. Section 6 of PL 97-348 exceptions include "maintenance, replacement, reconstruction, or repair of publicly owned or operated roads, structures, or facilities and establishment, operation, and maintenance of air and water navigation aids and devices and access thereto as long as the expenditure is consistent with purposes of PL 97-348" [9.2].

A construction project on a coastal barrier protected by CBRA could qualify as an exception to the funding prohibition. Consultation with the Fish and Wildlife Service is required. Results of consultation shall be incorporated in the environmental assessment. The environmental assessment should include analysis under other impact categories such as water quality, biotic communities, and construction impacts [9.2]. The available databases and a summary of data information can be found in Appendix W.

### 9.3.10 Wild and Scenic Rivers

There is a growing demand for the preservation and protection of wilderness areas and their river systems. The aesthetic value of these streams and rivers is important to the American people. The Wild and Scenic Rivers Act PL 90-542 protects "free flowing outstandingly remarkable scenic, recreational, geologic, fish and wildlife, historic, cultural or similar values" [9.2]. A national inventory of the river segments that appear to qualify for inclusion in the national system is maintained by the U.S. Department of Interior (DOI).

Verification with the DOI is required if a proposed construction project is in an area that could affect an inventory river. If the DOI indicates that an inventory river could be affected, the "Procedures for Interagency Consultation to Avoid or Mitigate Adverse Effects" circulated by the Council on Environmental Quality in August of 1980, provides guidance [9.2].

Actions which could adversely affect an inventory river include:

- 1) The destruction or alteration of the free flowing nature of the river
- 2) Introduction of visual, audible or other sensory intrusions which are out of character with the river or alter its setting
- 3) Deterioration of water quality

- 4) Transfer of property interests without adequate restrictions for protecting the river or its surrounding environment [9.6 and 9.7].

Rivers are classified as wild, scenic, or recreational. The following definitions are provided by the Wild and Scenic Rivers Act:

- 1) WILD RIVERS: rivers or sections of rivers that are free of impoundments and are generally inaccessible except by trail, with water sheds or shorelines essentially primitive and water are unpolluted
- 2) SCENIC RIVERS: rivers or sections of rivers that are free of impoundments, with shorelines or watersheds still largely undeveloped, but accessible in places by roads
- 3) RECREATIONAL RIVERS: rivers or sections of rivers that are readily accessible by road or railroad, that may have some development along their shoreline, and that may have undergone some impoundment or diversion in the past. The available data bases and a summary of data information can be found in Appendix X.

## 9.4 CONCLUSION

### 9.4.1 Applicability

The emergence of GIS can make the site planner more productive and permits greater flexibility. The most important aspect for a successful GIS implementation is the availability of digital spatial data. With a full compliment of basic data sets a site planner can investigate numerous options or use the same data in other non-related analyses. In the past field surveys for a single project required a site planner to assemble data by location and document the information in hard copy form. These data frequently could not be used for other purposes. Now data can be stored and reused in a GIS system.

A planner using an operational GIS system will save time in data collection over the long run and can focus on a more comprehensive evaluation methods. Major constraints to their broad use are the cost and time needed to develop useful data bases. Digital data is very expensive and difficult to produce properly; but, the rewards of maintaining digital data will outweigh the costs. A need exists to combine available data. Communities and private companies cannot afford to produce all of their individual data. A common data library would be beneficial for most every one. This is especially true at the national level. There is potential to incorporate the researched data bases into a national level GIS system. Problems with the availability of data, and its compatibility, should be a concern at this time. Additional data bases are provided at the state and local levels for all the environmental features. These data bases vary in format from one state to another. Yet, the data in each data base can be valuable and should be used. The difference in formats can be manipulated to access most GIS systems.

A national data base for all nine specific environmental features has not been completed however, many of the variables that must be considered for an airport site selection and impact analysis do exist in digital form. These data provide a basis for the implementation of a GIS in this problem domain.

The trend through the 1980's has been one of movement away from the traditional paper map to digital map. Both of the mapping agencies in the U.S. government, the Defense Mapping Agency and the Geological Survey, are continuously introducing new digital geographical data products and are taking steps toward the development of total digital map production facilities.

Federal regulations require the FAA to examine these nine environmental attributes in the planning phase of airport development. Future trends indicate that digital data will only increase in comprehensiveness and availability for these nine attributes. A GIS system, with the existing level of digital data available, will contribute in the site planning for airports. GIS contributions to planning will only increase as digital data becomes more available.

#### 9.4.2 Comprehensiveness

Environmental attributes digital data will increase over time. The major government mapping agencies are converting their data to digital form. Also, agencies responsible for maintaining and preserving these nine environmental attributes are indicating that their data will be available in digital form within the next ten years. Currently the historical, air quality, and water quality data are completely available in digital form. Of the nine environmental attributes, only the endangered species habitat, and floodplain data are not contained in some sort of digital format; and only the habitat data may never be completely comprehensive in digital form because of the political and technical difficulty in identifying such vast areas of land. Currently, there is potential for creating an airport and air route development three-dimensional planning GIS system. The data needed for developing such a GIS system to study potential sites at the national level in most instances is currently available in digital and non-digital form.

Developing a GIS system to aid in the selection of airport and aircraft routing is practical. Once the system is in place, GIS will have site information continually available as a resource. As data becomes more available at a national level, it would be programmed into the GIS system for evaluation. At the state level all the data is available in digital or map form. GIS is capable of generating sites, through the layering vital environmental information eligible for airport and aircraft routing as required in the environmental review process. Over the next decade there will be a dramatic expansion in the use of this type of three-dimensional information to evaluate airport environmental issues.



**NASA/GT**

AIRCRAFT NOISE ROUTE IMPACT ANALYSIS



# **SECTION 10**

**FEASIBILITY:  
COMPREHENSIVE THREE-  
DIMENSIONAL ROUTE  
IMPACT METHODOLOGY**

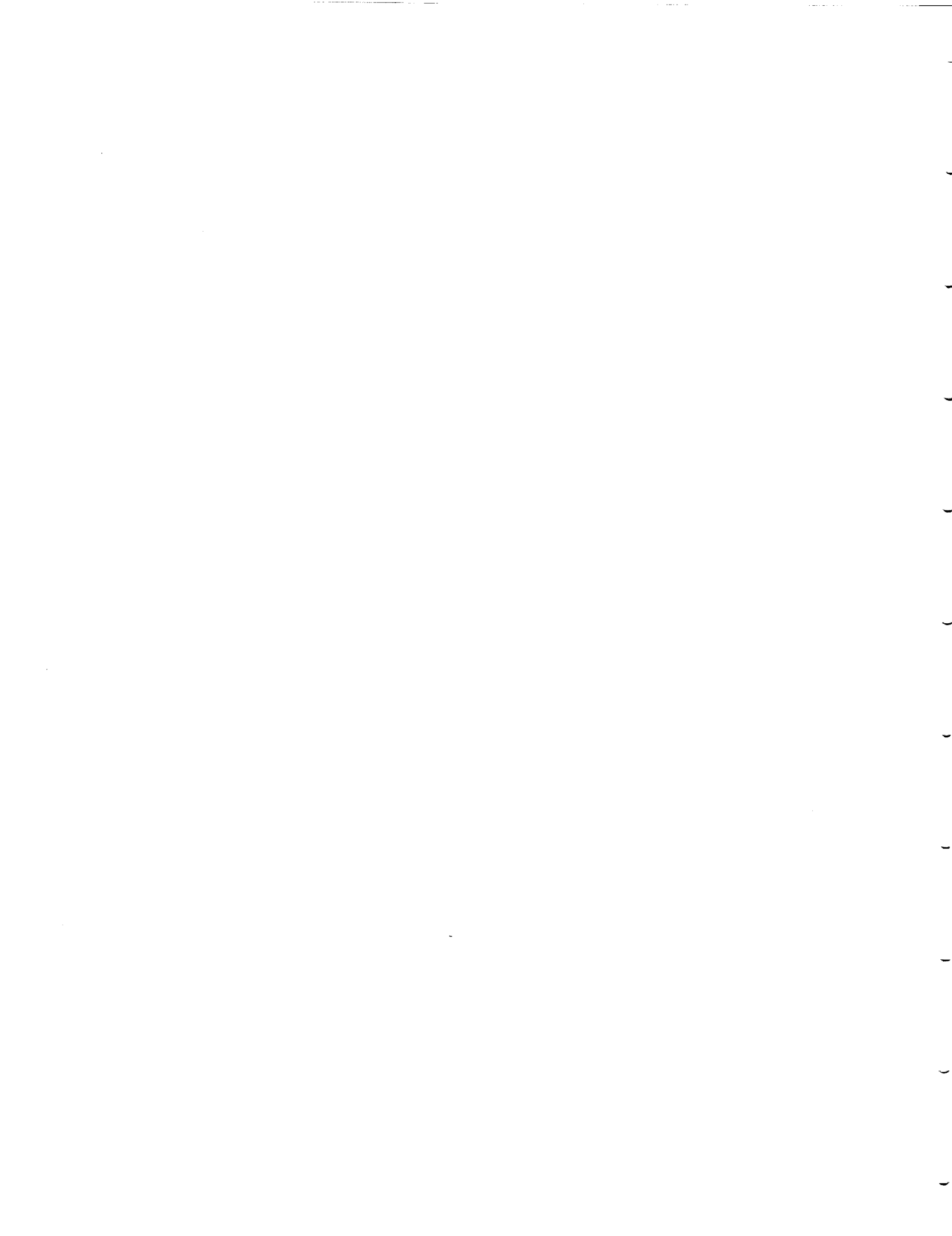

## 10.1 INTRODUCTION

### 10.1.1 Purpose

The purpose of this section is to integrate the results of these eight other subtasks to determine the feasibility of performing a three-dimensional route impact analysis that uses multi-senses (e.g. vision and sound) in a fixed frame and kinetic medium.

### 10.1.2 General

There is an increasing need to utilize a three-dimensional approach toward examining, analyzing, and planning the aviation routes within the biosphere. The biosphere is an appropriate reference base since it represents the total life support system for the earth, and it is three-dimensional in shape. For the most part, aircraft operations, their noise emission and propagation as well as "land" use impacts (including human and other animal populations and artifacts) are considered two dimensionally. A three-dimensional approach is absolutely critical since potential impacts do not take place at a surface or ground level elevation alone.

Aircraft related impacts involve more than just takeoffs and landings. Land use, or more accurately "space use" compatibility planning, may also include high and/or low level flight activity. Such operations could involve civilian or military based aircraft as part of either a commercial or military mission. Table 10.1 indicates the various operational parameters of aircraft routing. All aspects must be addressed including take off, landing, runway and flyover related aircraft noise. Noise associated with these operations depending in part on the speed of aircraft can be either sonic or subsonic. These aircraft produce steady-state or impulsive type acoustic signatures. Clearly the sound is treated as a static two-dimensional phenomena, but in reality it is kinetic, temporal, as well as three-dimensional. A coined word that depicts this concept is geosonics (Figure 10.1). A combination of sound and geography, this term relates the environmental sound source to the morphology of settlement patterns, both natural and manmade, as they occur within our ecosystem [10.1]. Geosonics therefore refers to geographically distributed sound data. To be totally representational, a geographic profile of aircraft routes should be reproduced three-dimensionally, temporally (selected time histories, daily, seasonally, annually) as well as kinetically (in motion indicating the impact of the sound signature occurring through space).

Table 10.1 Aircraft routing operational parameters

Aircraft Type	Takeoff	Landing	Flyover		Runup
			High Alt	Low Alt	
Fixed wing	x	x	x	x	x
Rotary wing	x	x		x	x

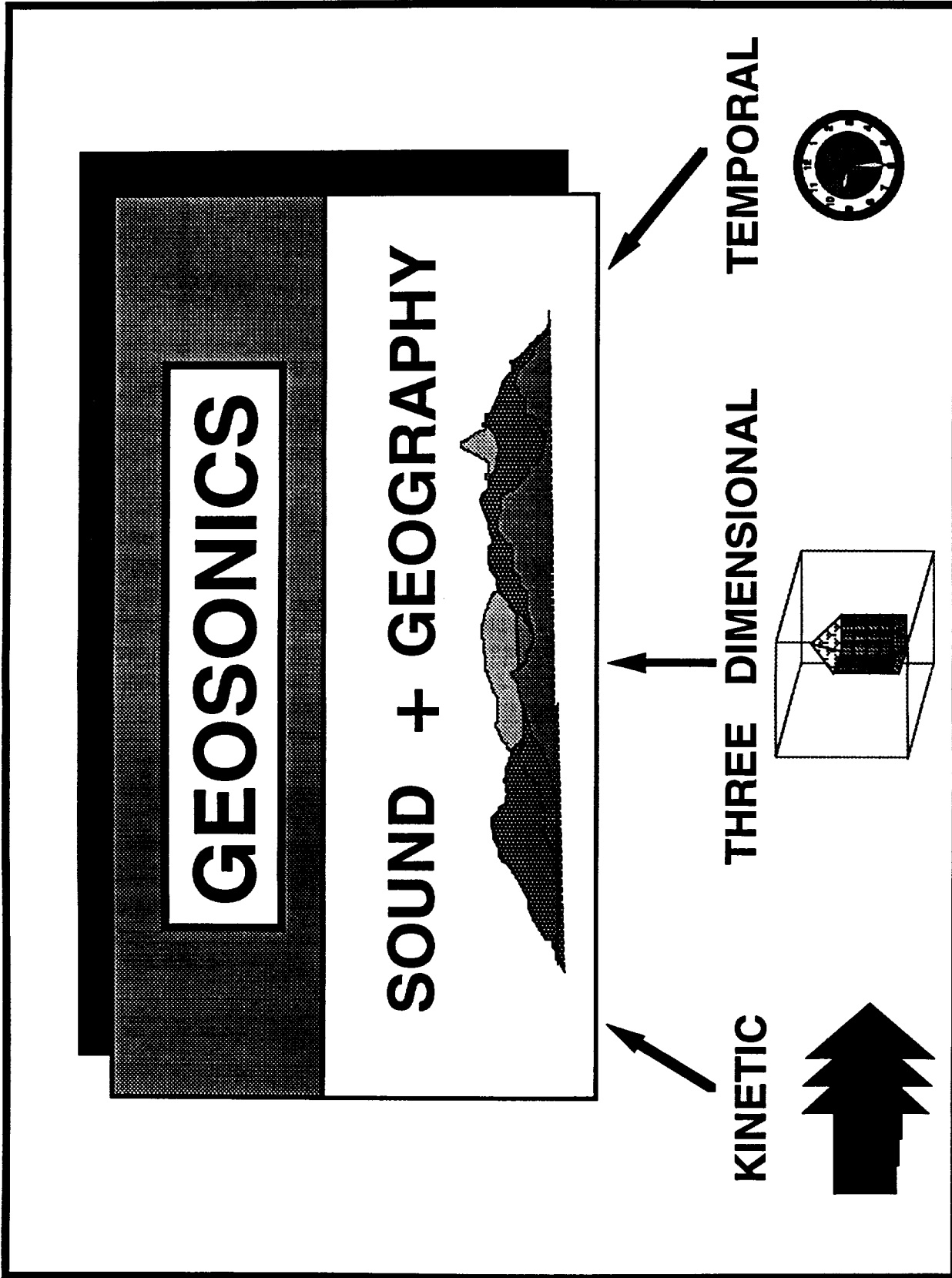

Figure 10.1 Geosonics: Geographically distributed sound data.

The development of the multi-media interactive presentation for the City of Atlanta's successful bid to host the 1996 Summer Olympics has stimulated expansion of this earlier concept for aviation planning and simulation. Three Georgia Tech faculty applied these principles to potential Olympic venue sites for a vertical flight system of vertiports [10.2]. One site examined in a graduate city planning study was proposed to be located over the air rights of Interstates 75 and 85 in midtown Atlanta. Referred to as a vertiport, this was being planned as a vertical multi-modal gateway to the city.

A three-dimensional approach into the vertiport was proposed, based on certain aircraft parameters and simulation commands, as shown in Figure 10.2. Each of these commands represented an overlay as part of the Atlanta Vertiport data base system. A terminal en route system (TERPS) was proposed over Interstate 75/85 as one overlay (Figure 10.2,) to avoid residential or institutional land uses. A second overlay addressed possible airspace or height obstacles in the approach and departure corridors (Figure 10.4). Noise contours (DNL) averaged over a 24-hour day were prepared indicating the 65, 60, and 55 Ldn in Figure 10.5. All of this analysis was applied to the V22 tiltwing aircraft (i.e. Bell-Boeing joint venture) using a computer visualization process.

This emerging multi-sensory technology applied to airport/aviation planning has considerable potential for assisting in making decisions about environmental and public policy issues, including routing. Geographic Information Systems (GIS) is an essential ingredient to this planning process since it involves the technology for collection, management and analysis of spatial data. GIS is a newly developing technology. We will review GIS as it exists to address this problem and then discuss the future potential (development) of GIS and related technologies (visualization, integration with existing modeling capabilities) as a tool in comprehensive planning for aviation systems.

This geosonic approach is an important tool that has immediate application to such activities as airport master planning, FAA supported Part 150 studies (i.e. Airport Noise and Land Use Compatibility) as well as environmental impact assessments or related studies. Such a tool could have been highly useful in the Eastcoast plan mandated by Congress, to review air traffic routes over several populated northeastern states.

## 10.2 DATA BASE SUMMARY

### 10.2.1 Data Cost

Geographically referenced data bases are clearly important in order to adequately address regulatory issues regarding the impact of airport and flight operations. This study has attempted to identify the type of data needed for an analysis of impact and, in particular, the availability of such data in digital formats. The latter aspect is particularly important because of the relative costs and difficulties involved in geographic data collection and encoding. It is by far the major cost in the successful implementation of GIS technology.

### THREE - DIMENSIONAL AVIATION APPROACH SIMULATION

AIRCRAFT PARAMETERS		SIMULATION COMMANDS	
TYPE A/C	APPROACH	<input type="radio"/> TERPS AIRSPACE <small>(Terminal Instrument Procedures)</small>	<input type="radio"/> MISSED APPROACH
ENGINE	HEADING	<input type="radio"/> NOISE CONTOURS	<input type="radio"/> HEIGHT OBSTACLES
AIR SPEED	DISTANCE TO TLOF**		
DISTANCE TO FATO*			

\*FATO - FINAL APPROACH AND TAKEOFF AREA    \*\*TLOF - TOUCHDOWN AND LIFTOFF SURFACE

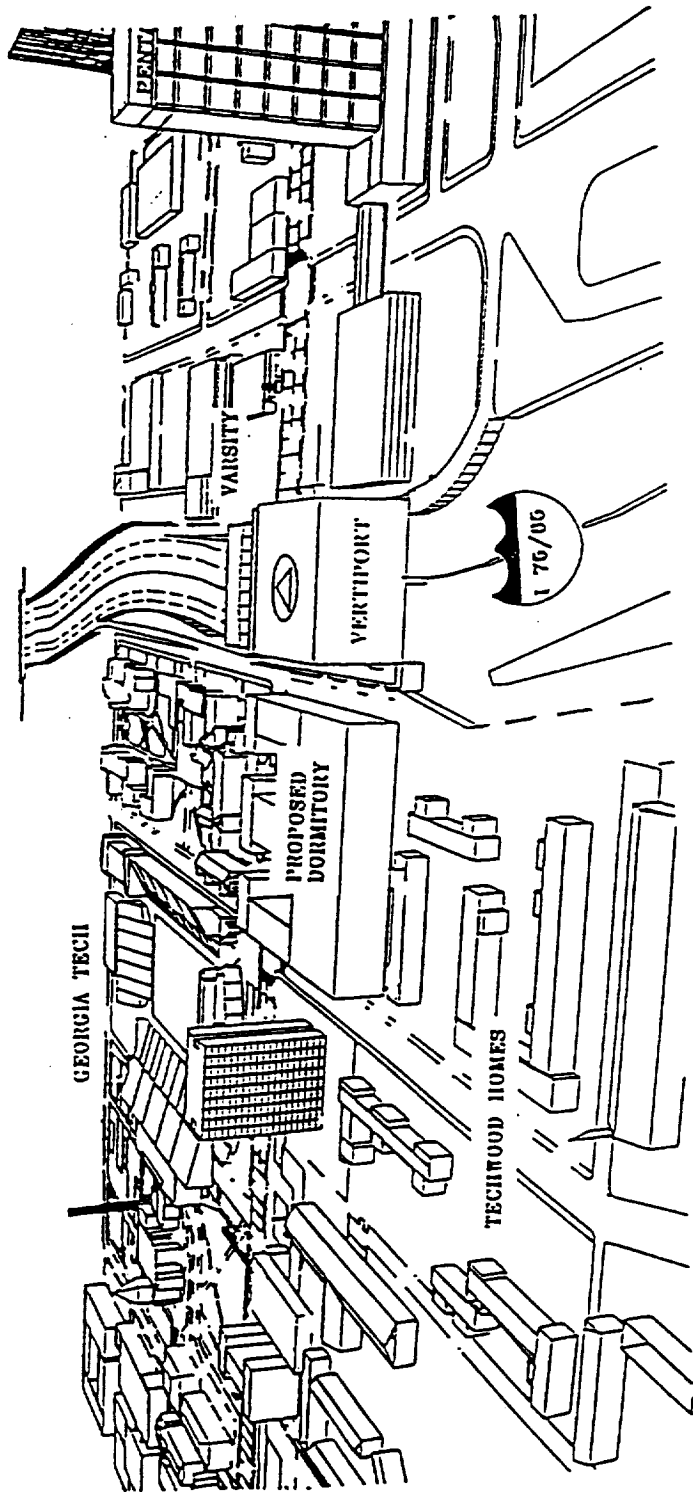

Figure 10.2 Atlanta vertiport: A three - dimensional approach simulation.

### THREE - DIMENSIONAL AVIATION APPROACH SIMULATION

#### AIRCRAFT PARAMETERS

TYPE A/C

ENGINE

AIR SPEED

DISTANCE TO FATO\*

APPROACH

HEADING

DISTANCE TO TLOF\*\*



#### SIMULATION COMMANDS

TERP'S AIRSPACE  
(Terminal Instrument Procedures)

MISSED APPROACH

NOISE CONTOURS

HEIGHT OBSTACLES

\*FATO - FINAL APPROACH AND TAKEOFF AREA

\*\*TLOF - TOUCHDOWN AND LIFTOFF SURFACE

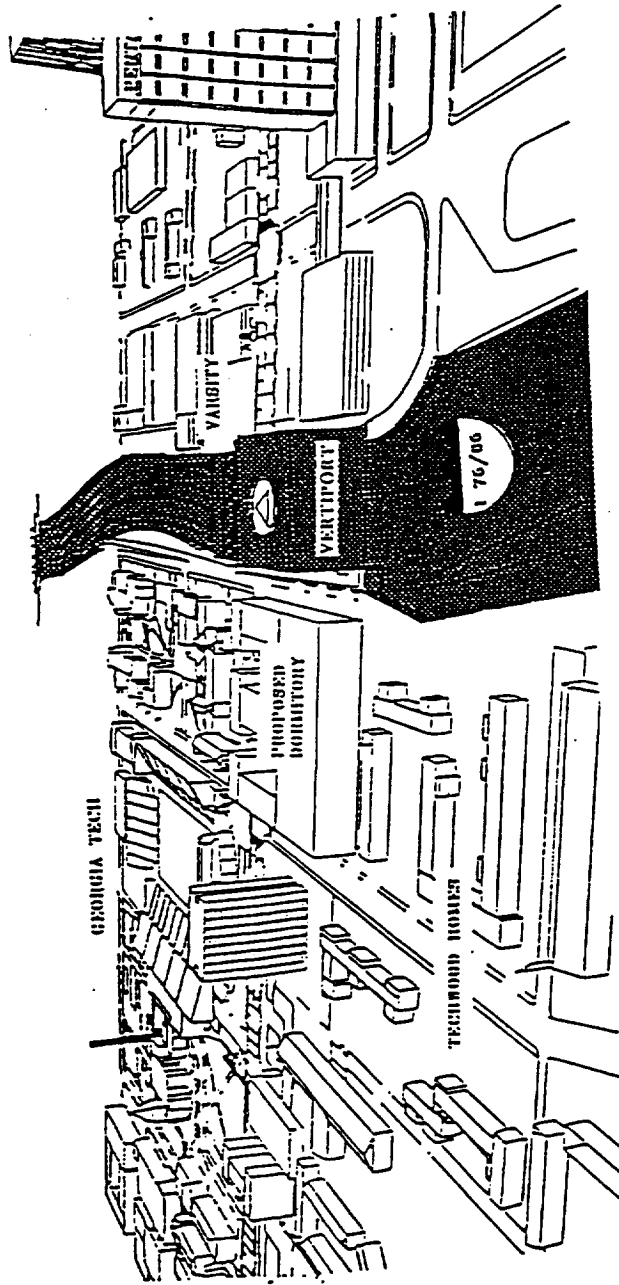



Figure 10.3 Atlanta vertport: A three - dimensional approach simulation - Terminal Instrument Procedures.

### THREE - DIMENSIONAL AVIATION APPROACH SIMULATION

AIRCRAFT PARAMETERS		SIMULATION COMMANDS	
TYPE A/C	APPROACH	● TERPS AIRSPACE <small>(Terminal Instrument Procedures)</small>	● MISSED APPROACH
ENGINE	HEADING	● NOISE CONTOURS	●/✓ HEIGHT OBSTACLES
AIR SPEED	DISTANCE TO TLOF**		
DISTANCE TO FATO*	DISTANCE TO FATO*		

\*FATO - FINAL APPROACH AND TAKEOFF AREA    \*\*TLOF - TOUCHDOWN AND LIFTOFF SURFACE

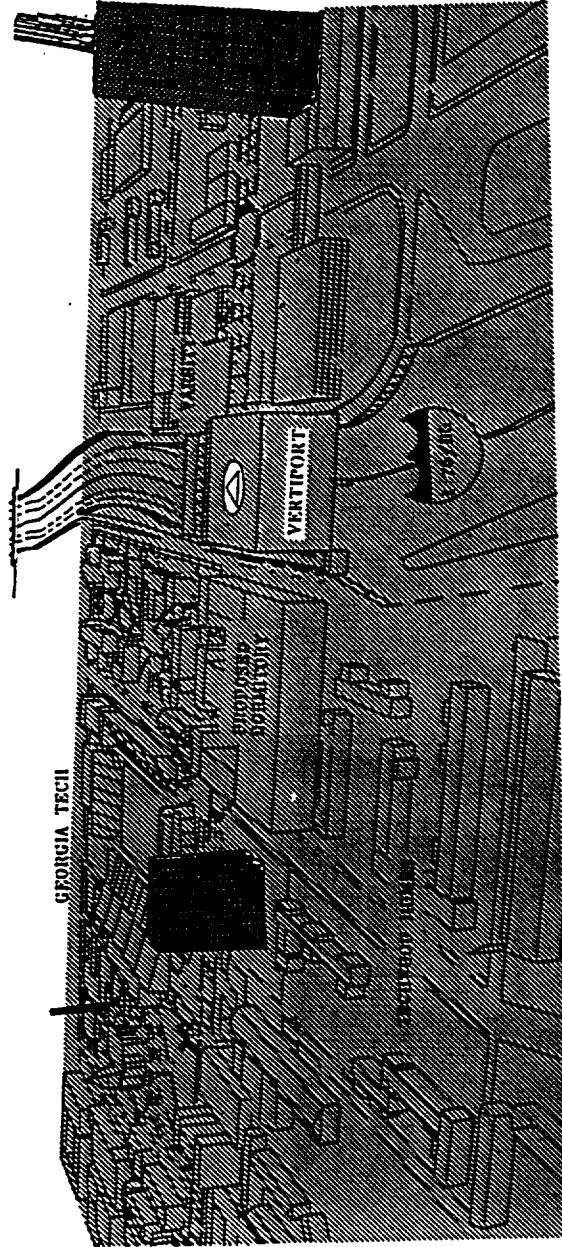



Figure 10.4 Atlanta vertiport: A three - dimensional approach simulation - Height obstacles.



### THREE - DIMENSIONAL AVIATION APPROACH SIMULATION

#### AIRCRAFT PARAMETERS

TYPE A/C	APPROACH	<input type="checkbox"/>
ENGINE	HEADING	<input type="checkbox"/>
AIR SPEED	DISTANCE TO TLOF**	<input type="checkbox"/>
DISTANCE TO FATO*		<input type="checkbox"/>

#### SIMULATION COMMANDS

- TERPS AIRSPACE  
(Terminal Instrument Procedures)
- MISSED APPROACH
- NOISE CONTOURS
- HEIGHT OBSTACLES

\*FATO - FINAL APPROACH AND TAKEOFF AREA    \*\*TLOF - TOUCHDOWN AND LIFTOFF SURFACE

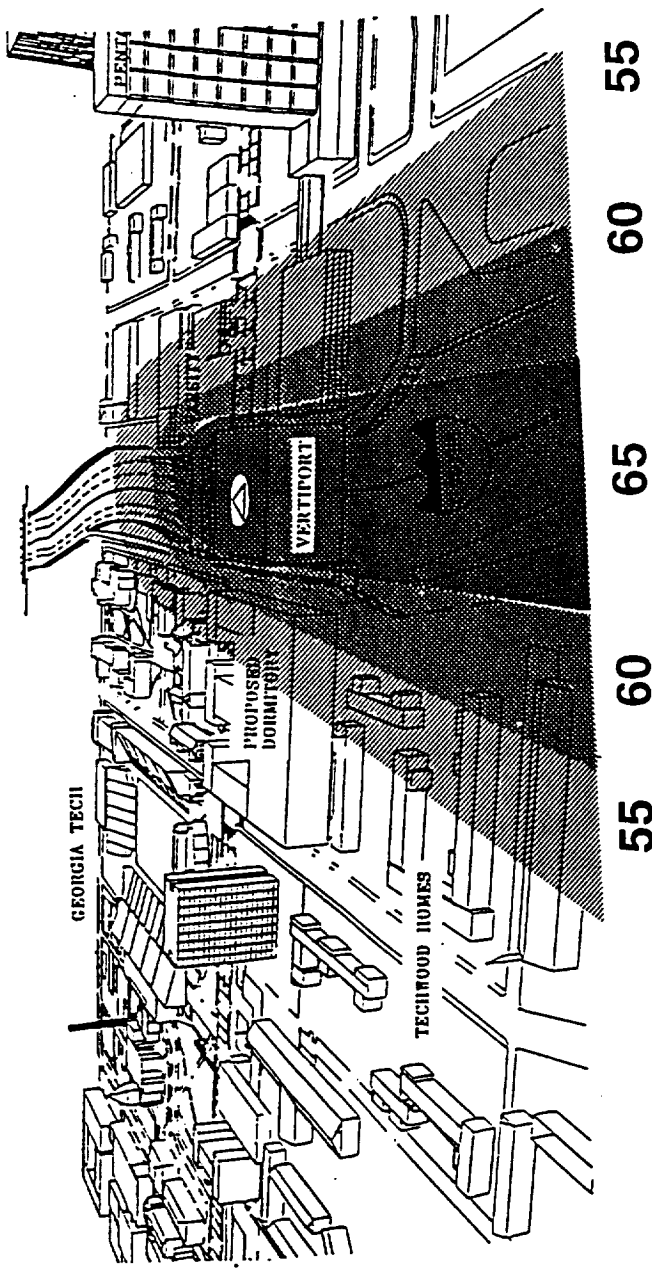

Figure 10.5 Atlanta vertiport: A three - dimensional approach simulation - Noise contours (DNL).

Early geographic data collection was based on manual techniques. Field surveys, and manual extraction of information from maps and air photos were the common approaches. Today's electronic digitizers are a major improvement but still consume many man-hours of an operators time. Recent advances in scanner hardware and software will further reduce an operators effort. Paper maps can be scanned and lines following algorithms can be used to extract the spatial definition of selected information that gives meaning to the line definitions. Even more important, it assumes base data are available in map form.

Satellite collection systems, such as LANDSAT, have been, and will be, important sources of GIS data. Their advantages include: repetitive coverage through time; data available for all locations and in a consistent format; the utility of the data for natural resource issues; and a reasonably low cost per unit area. Nevertheless, the final data cost will go much higher. Generally, the raw data must be processed by a skilled operator through a series of complex algorithms before they are usable in a GIS environment. Finally, for the purposes of this study, satellite collection systems can only provide a subset for the total data requirements.

In the final analysis, data costs for a GIS implementation can best be understood by evaluating two factors: the application requirements, which translates into the number of variables collected, and the size of the area the system must process. The requirements identified herein were comprehensive, including both socio-economic and numerous physical environmental impacts. Moreover, the system must be able to evaluate conditions nationwide. For these reasons, one primary emphasis of this study has been the utility and availability of existing nationwide data.

#### 10.2.2 Data Availability Trends

One factor clearly impacting data availability is the dramatic growth in GIS usage. At all levels of government, there are data producers and consumers. In past years, a primary data source for geographic information has been the standard topographic map sheets produced by the National Mapping Division (NMD) of the U.S. Geological Survey. Recently, however, studies have shown that the information content is clearly inadequate for almost all uses [10.3, 10.4]. Much of the information content (e.g. elevation, roads) is available in digital format and previous map users are now choosing the latter. Consequently, the NMP is critically evaluating map data requirements (including digital) for future products. By maintaining digital data sets of numerous variables, one could produce maps customized to a specific issue. Small pilot studies designed to assist local governments are currently underway based on this concept. Such a revised mapping effort at the National level will tremendously affect data availability.

The Defense Mapping Agency (DMA) has been evolving steadily in this direction. Weapon systems, planning systems, simulators, and other high technology systems are dependent upon digital geographic data. Even the DMA-produced standard maps are

being made available in a digital image format. DMA is continually expanding both the types of information available and its production facilities. Advances in technology made by this organization will ultimately impact data collection and availability in other sectors.

Other Federal agencies are also contributing to the overall availability of digital data. These data have been collected originally to assist in the day to day operations of the respective agency, but ultimately, it was recognized that they had an importance for addressing other diverse problem domains. Subsequently, the data were made available and are now in common usage. The TIGER file, introduced in Section 8, is an excellent example of this process. Considering the expansion in GIS usage by Federal agencies, it is not hard to assume that even more data sets will be made available in the future.

Commercial firms, recognizing the difficulties of geographic data collection and the value of information, are offering packages of multi-variable data for sale. Some firms are in business solely to produce the data, but others sell both GIS software and data.

### 10.2.3 Standards

GIS, like most new technologies, developed without a consistent set of guidelines to assure conformity and hence interchangeability. Again, the difficulties and cost of developing digital geographic data make this situation one of critical importance. At all levels of government, local, state and federal, and within the private sector, there are activities underway to create an environment for sharing data. The development of the proposed methodology for evaluating impacts of airport and flight operations, in the long run, is dependent upon the utilization of many data sets developed by other organizations. This study, therefore, has also focused on the nature of the data bases identified as applicable to the problem at hand. Also, each GIS was evaluated in terms of its ability to operate with multiple data characteristics.

The critical aspects of geographic data that must be recognized are: 1) the coordinate system and reference datum; 2) the data structure used to represent space; 3) the source scale of the data; 4) classification schemes used to characterize the data; and 5) the export format for the data product. Another attribute that may have to be considered in the near future is compression techniques used on the data. Of lesser importance is the media used to distribute the data. Generally, an incompatibility in this area can be solved by a reasonably low cost purchase (e.g. CD-ROM drive) of the GIS supports device.

Coordinate systems and the associated reference datum are an often overlooked but potential problem area within the GIS technology. Depending on the accuracy requirements of the problem domain, serious positional errors can be introduced if this attribute is not systematically evaluated. There are a number of planar cartesian coordinate systems and geodetic coordinates based on multiple reference datums in existence and in use. The increased use of the new North American Datum 1983

(NAD83) and the Global Positioning System (GPS) will further compound this problem. A candidate GIS should be evaluated regarding any a priori assumptions concerning coordinates and datums and the ability of the software to transform coordinates between multiple systems and datums. The goal is to have a single consistent scheme within all data bases on a system. The previous sections identified that not all available data bases have such common references. Fortunately, the more advanced systems, identified in Section 2, have well developed transformation capabilities.

Data structure compatibility is another important issue when evaluating the utility of existing data sets. Section 2 introduced some of the most common structures (point, line, polygon, topological, and raster), and other unique types are continually being developed. Many low and medium priced systems have the capability to convert or use multiple types. No standards exist in these areas.

The source scale of data is an issue that has subtle implications for impact analysis. Scale relates to levels of generalization within the data, and hence to the inferences that can be made by using the data for analysis. Very large-scale urban data bases, for example, can have detailed information down to the block face, whereas smaller scale source materials may only permit differentiation of high density versus low density urban activities. The inferences or associations that can be made based on the nature of the data should show a corresponding level of generalization. Mixture of data derived from a variety of scales possibly can contribute to false interpretations of the actual conditions.

Classification schemes applied to data deserve attention to assure that the data set contains the information needed for a particular application. A soils data base, for example, can be classified according to a variety of schemes. Soils can be defined by their formation environment (source bedrock, climate), or by engineering properties or other attributes. Fortunately, some standards exist. Federal Information Processing Standards (FIPS) codes are used where applicable in many federally produced data sets; however, other data sets may reflect the original intent for which a data set was derived.

Export format relates directly to the capability of exchanging data developed within any given geographic data processing environment and its use within another environment. The format is comprised of the physical order and field definitions of data items within a file, the encoding process (e.g. binary, ASCII, etc.), and header or trailer information written by the data processing system. Detailed format documentation is available for many of the nationwide data bases identified in earlier sections (e.g. TIGER, DLG) so that software developers can build applications. Most commercial GIS's currently can import one or more of these data sets. The situation is not so straight forward, however, when exchanging data between different GIS packages. For competitive reasons, most GIS developers have restricted or carefully limited the dissemination of format information. The negative result is that a data developer may be amenable to sharing data, but system incompatibility negates the process.

The desire to exchange data because of cost combined with the data incompatibility problem between systems has led to a call for data exchange standards. One major response has been the creation of the Spatial Data Transfer Standard which is currently in the approval stage by the National Institute of Standards and Technology (NIS). Upon approval, it will become a Federal Information Processing Standard (FIPS). The Federal Geographic Data Committee (formerly the Federal Interagency Coordinating Committee on Digital Cartography), a consortium of representatives from Federal agencies with an interest in geographic data, provided the coordination, and the U.S. Geological Survey developed the technical details of SDTS. Input was made by members of the GIS and mapping communities from both the private sector and academia. It is hoped that there are no technical shortcomings, business decisions, or other reasons that will impede the implementation of this standard.

In the absence of formal standards, it should be noted that several de facto standards have emerged as GIS technology has developed. Certain GIS packages, because of their commercial success, have had their export file formats become de facto standards. Other GIS companies, generally through contractual arrangements, have developed the capability to import data from these formats. These formats have been identified in the data tables for Section 2, included in Appendix B.

A final factor that may affect data exchange is data compression technology. It has been noted throughout that GIS data sets can become extremely large, and for this reason, compression software has been developed. To date, most implementation has been associated with the image data, but these same techniques can be applied readily to grided data sets. Once a compression algorithm has been applied to data, any subsequent user must apply a decompression algorithm based on the identical technique. The Department of Defense has taken the lead in the image area and developed the National Imagery Transmission Format (NITF). Within this program, the Joint Photographic Experts Group (JPEG) has defined a series of compression algorithms under the NITF.

#### 10.2.4 Summary

Viewed from a discrete point in time, the status of geographical data include the following:

- 1) nationwide coverage does not exist for all variables that are necessary for a comprehensive impact assessment tool; and
- 2) there can be technical compatibility issues between diverse data sets.

However, when viewed along a time continuum, the situation changes. The increase in available digital geographic data has been monumental, and all indications suggest the trend will accelerate through this decade [10.5].

Where specific data do not exist, other options have to be identified. State and local governments are possible sources for data, especially when an analysis is limited to a specific site and the impact does not cross state boundaries. Some analyses could cross boundaries, especially if the data are derived from satellite collection systems. Many states, for example, have used LANDSAT data for the identification of wetlands. A second approach is to derive the missing data from an analysis of existing data. Wildlife habitat was presented as an example. Other data can be generated by spatial models using GIS data or by using existing GIS functions. FAA regulations that have geographical definitions were researched, but corresponding digital data could not be located. Many of the definitions were based on distance or radii. Many GIS packages can generate secondary data sets based on a set radius from a point or distance from other features.

Likewise, the technical compatibility issues are being recognized and solved. Most GIS developers provide the capability to operate between multiple coordinate types and have recognized and account for the multiple datum problem. Scale issues are best handled by user education and by thorough documentation of data bases. In many states and at the federal level, ad hoc organizations are forming for purposes of exchanging data, and one of the first steps in the process is the establishment of data documentation standards. The Spatial Data Transfer Standard contains a section to document the lineage history of a data set. Finally, and most significantly, the SDTS directly addresses the movement of data between incompatible systems.

### 10.3 GIS STATUS

GIS is best viewed as one of the newer computer technologies that is still in its infancy. Geographic data processing techniques were being developed back in the 1960's, but the first commercial "information system" did not appear until the latter 1970's and early 1980's. The past several years have witnessed a virtual explosion in the use of the technology in diverse areas of both the public and private sectors.

Data volume have always been a concern in the GIS industry. Single scenes derived from multi-spectral scanners on satellites contain tens of megabytes of data. Coordinate strings defining the spatial extent of numerous other variables add significantly to the magnitude. Some data bases for global applications are in the terabyte range. Fortunately, GIS has benefitted from corresponding hardware and software advances in data storage technology.

Both CD-ROM and erasable optical disks have had a major impact in recent years. Large geographically encoded data bases are commonly provided to the public in CD-ROM format from both public and private data procedures. The optical disk "jukebox" is pushing on-line storage volumes toward the terabyte range. These hardware devices consist of several erasable optical disks and software to manage the distribution for data. This technology and its follow-on will make the development of a nationwide impact

methodology feasible. Clearly, the ability to operate the on-line data makes a system more usable, in particular within the computer work station environment.

Data compression algorithms, discussed above, further add to the ability to handle large volumes of data. The more sophisticated algorithms are claiming compression ratios of 200:1. Hardware implementation of compression algorithms are also being announced. New data structures such as Triangulated Irregular Networks (TIN) and Quad-trees have the effect of reducing storage requirements for certain types of data bases.

### 10.3.1 Three-Dimensional Aspects

This study has identified the need for a three-dimensional approach to spatial data and analysis. Impacts and regulatory areas extend from the surface into the vertical planes. The problem, however, is that existing commercial GIS packages view geographic data as zero, one, or two dimensional. The analogy is the weather map that includes surface features as well as atmospheric data plotted on a two-dimensional paper plane.

Current technology allows for an approximation of three-dimensional data by creating a series of data layers where each represents a slice at a given above or below ground level. As the number of slices increases the data approach a near continuous representation. Nevertheless, explicit connectivity that would define a coherent three-dimensional object is absent, and that could present problems if serious modeling were attempted.

Research organizations and some commercial GIS vendors are looking at three-dimensional data structures. The approaches range from regular partitioning of space, with such types as voxels and oct-trees, to irregular polygonal meshes. Each will be evaluated against the factors that have effected the development of two-dimensional structures: the growth in data storage requirements; coordinate concepts; and how the data structure will support spatial analysis and modeling.

## 10.4 TRENDS AND FUTURE CAPABILITIES

The visualization of future issues requiring decisions of a public nature is rapidly coming into its own. Using computing environments which utilize parallel architecture, networks and data sharing, telecommunications technology and its use in conflict resolution, such analysis can be brought into the decision making planning process.

The integration of GIS with other advanced computing technologies provides greater insights to airport communities. Work in this area which relates GIS to airport noise compatibility planning is less than a decade old. A noise envelope (eg. equal energy noise contour) can be projected over selected data bases, including population





census and land (space) use information. The progression of this into a three-dimensional format enhances the potential utility of this methodology as we begin to address the verticality of space including altitude and associated space use developments that occur at various elevations.

Aircraft route noise impact simulation presents the opportunity for an electronic dress rehearsal using state-of-the-art computer technology. Figure 10.6 displays an electronic command center for assessing aircraft route noise impact simulation. The first parameter of interest addresses aircraft operational characteristics which include takeoff, landing, flyover (high and low altitude), and engine runup factors. Noise generation will vary depending upon the operational condition of the aircraft. Aircraft parameters include the type of aircraft, altitude, heading, air speed along with a series of noise abatement procedures in place for the location and route of interest. Lastly, there are a series of noise impact assessment commands that are display outputs. These outputs can detail noise contours, height obstacles, population exposure, exposure of structures, land use incompatibility and applicable regulatory controls. All of these commands could be displayed as part of a pre-flight/pre-route simulation rehearsal in order to make appropriate adjustments before establishing a final course of action.

This technology which integrates sound with vision can then be used to examine the siting of airports as well as simulating approach and departure profiles and flight tracks through the air traffic control system. The layering of these data bases can then be strategically combined to review such things as alternative spatial alignments over various settlement patterns to develop a course of least resistance which is most compatible with the ecosystem. In time, geosonic analysis will be able to be developed into a highly sophisticated and compact digital electronic system. Electronically based multi-media technology will be applied to nearly real time decision making, with the effective coupling of GIS and acoustical modelling to selected environments of interest. This highly responsive interactive electronic assessment process will displace the more traditional and deliberate environmental impact methods now in use.

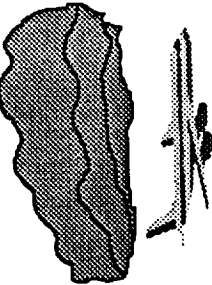
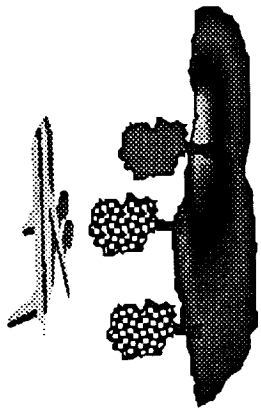

# OPERATIONAL PARAMETERS

TAKEOFF	LANDING	FLYOVER		RUNUP
		HIGH ALTITUDE	LOW ALTITUDE	
				

AIRCRAFT PARAMETERS		NOISE IMPACT ASSESSMENT COMMANDS	
AIRCRAFT TYPE	<input type="text"/>	<input type="radio"/> NOISE CONTOURS	<input type="radio"/> POPULATION EXPOSURE
ALTITUDE	<input type="text"/>	<input type="radio"/> HEIGHT OBSTACLES	<input type="radio"/> STRUCTURE EXPOSURE
HEADING	<input type="text"/>	<input type="radio"/> LAND USE INCOMPATIBILITY	<input type="radio"/> REGULATORY CONTROLS
AIR SPEED	<input type="text"/>	NOISE ABATEMENT PROCEDURES	<input type="radio"/> _____ <input type="radio"/> _____ <input type="radio"/> _____ <input type="radio"/> _____

Figure 10.6 Aviation route noise impact simulation.

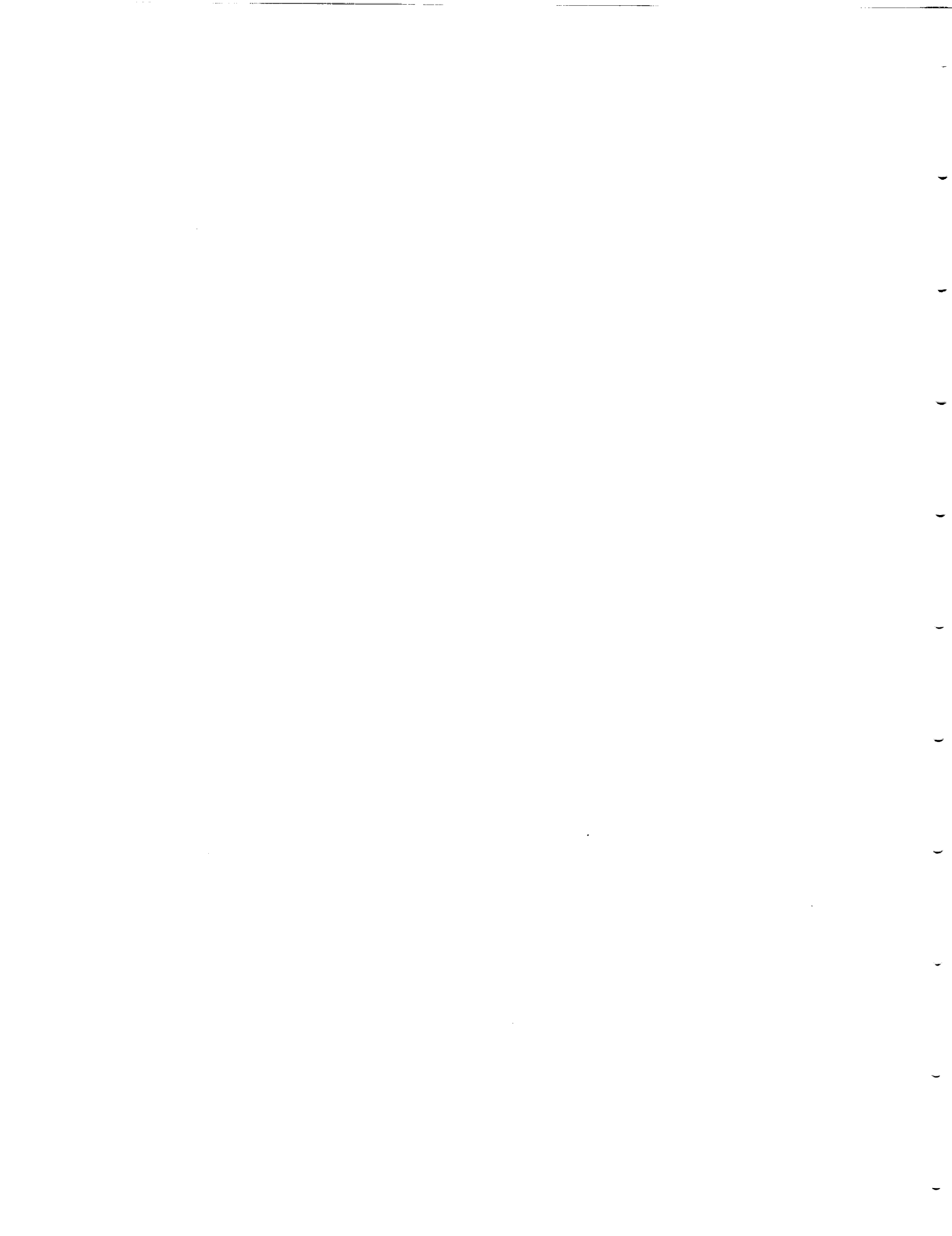

APPENDIX A: GLOSSARY OF GIS TERMS

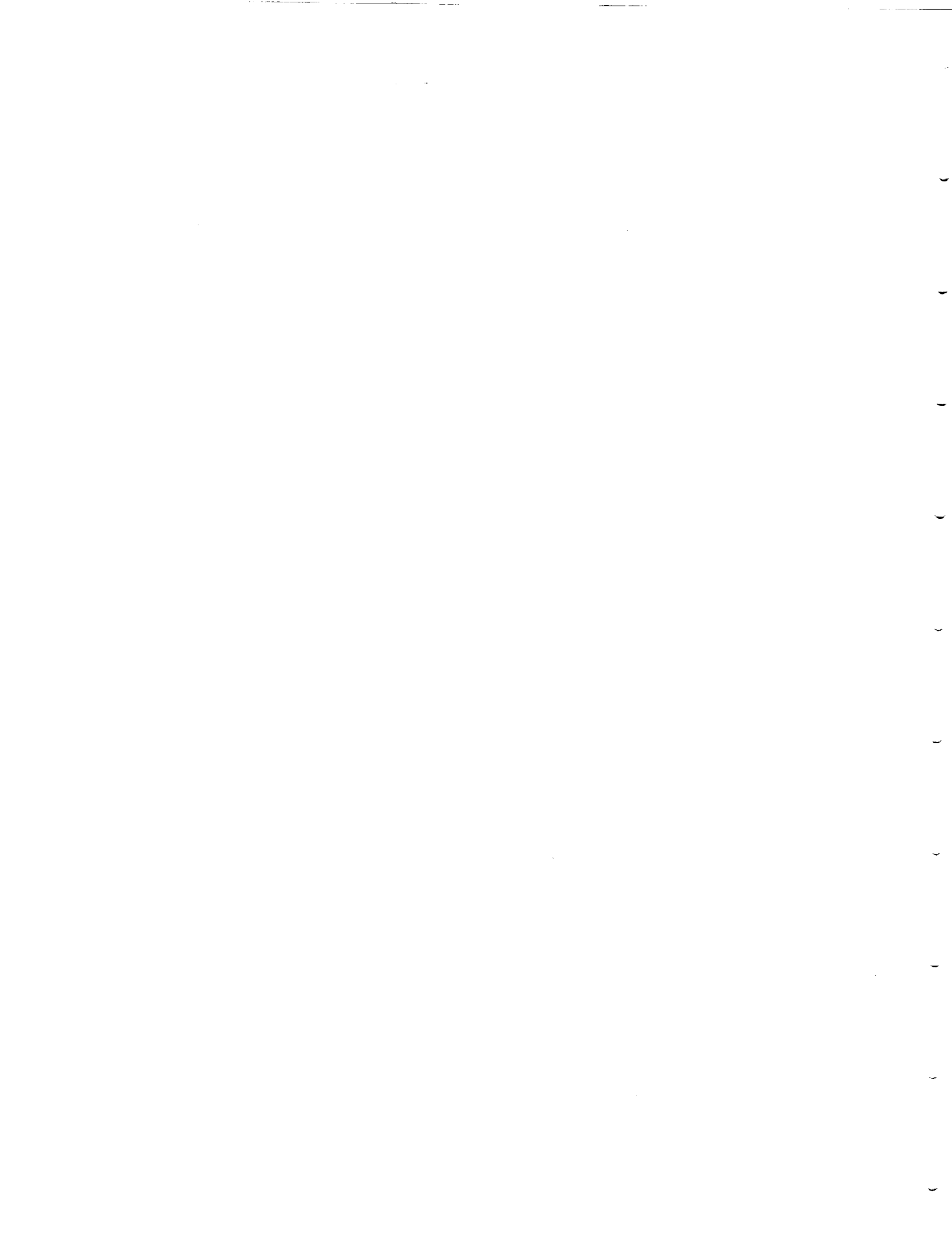

**Base Map** Fundamental map information, either as one layer or a combination of layers, which is used as a standard framework upon which additional data of a specific nature is overlaid.

**Buffering** A spatial analysis function that forms a polygon around a point, line, or other polygon by locating its boundaries at a certain distance from the point, line, or polygon.

**Data Base** A Collection of interrelated data that is stored in a computerized information system to serve one or more applications and is independent of the computer programs that use it.

**Digitizer** A small device guided by a human operator over the surface of a digitizing table to either position the cursor on the computer terminal screen or to identify the locations of cartographic features on a hardcopy map for the purpose of entering their coordinates into the computer.

**Geographic Information System (GIS)** A computerized data base system for capture, storage, retrieval, analysis, and display of spatial data.

**Line\*** A unit of spatial information consisting of a segment connecting to points.

**Map Layer** A grouping of homogeneous map information that is stored or identified separate from other map layers.

**Network Analysis** A spatial analysis function that uses the topological structure of lines to follow a path along an interconnected network and then process attribute data associated with line segments.

**Point\*** The smallest unit of spatial information referring to one particular location.

**Polygon\*** A unit of spatial information consisting of a series of points connected by line segments creating closure.

**Plotter** A hardware device for a computer system that produces hardcopy graphic outputs called "plots".

**Raster** A method of displaying or storing graphic data that uses individual points for processing.

**Spatial Data\*** Data pertaining to a particular location in three-dimensional space.

**Topological Data Structure** The explicit definition of how map features represented by points, lines, and areas are related.

Vector\* A type of data structure consisting of data stored for points, lines and polygons.

Work Station A combination of hardware and software normally used by one person to interact with a computer system.

Digital Elevation Model (DEM's):

All references, unless marked with an asterisk (\*) are from reference as noted below.

Huxhold, William E., An Introduction to Urban Geographic Information Systems, New York: Oxford University Press, 1991.

APPENDIX B: GIS SOFTWARE EVALUATION MATRIX

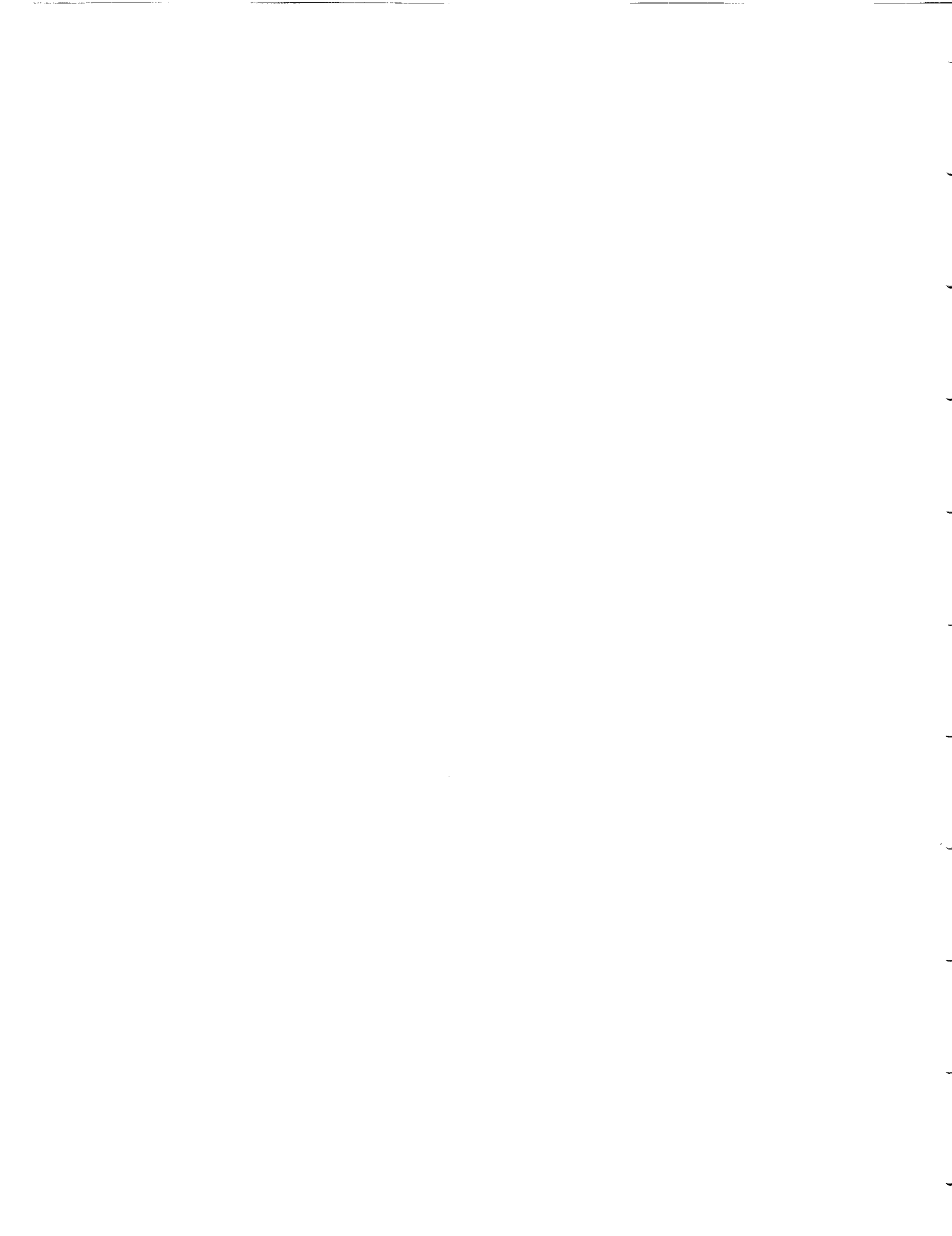



APPENDIX B  
GIS SOFTWARE EVALUATION MATRIX

		VENDOR		
QUESTION	INTERGRAPH	GENERATION-5	GRASS	
Name, Address, and Phone Number	Peter Owen, Product Planner Intergraph Corporation Huntsville, Alabama, 35894-0001 (205) 730-1915	Ally Bailey, V.P. Operations Generation-5 Technology Inc., 8670 Wolff Court, Suite 120 Denver, Colorado, 80030 (303) 427-0055	Shella Gooden DBA Systems 10560 Arrowhead Drive Fairfax, Virginia, 22030 (703) 934-6765	
GIS Data Storage: Raster or Vector	Both	Both	Both	
Operating Hardware (minimum required)	Unix, some PC (Intergraph 2000)	Unix, PC (386)	Unix, PC (386)	
Input Peripherals	CD ROM, Disc, Scanner, Video, Digitizer	Digitized, Scanner	Digitizer	
What publically available data files can be translated	TIGER, DIME, ETAK, DLG, SPOT, PL-941	DIME, DLG, TIGER, ETAK, DTM, SPOT	DLG, DEM, SPOT, TIGER	
What other GIS can be inputted	GEOVISION, GENASYS	ARC/info, Intergraph	ARC/info	
Coordinate System and Data	Flexible	Flexible	UTM-Lat/Long, State Plane or User Defined	
Is there an upper limit to database	Relational database - hardware limited	Relational database - hardware limited	No limit	
Is there a data layer limit	No limit	No limit	No limit	
Is there a upper limit to data per layer	Relational database - hardware limited	Relational database - hardware limited	Source code available for entire package	
Toolkit Available	GOAL - Program language applications	Structured command language	Surface capability only	
3-D Analysis	Voxel 3-D analysis package	Can bring 3-D Cad image to analysis	Proximity analysis, Logical reasoning,	
Other Analytical Capabilities	Grid analysis, Spatial analysis, Buffer analysis, Network analysis, Terrain modeler	Network analysis, Spatial overlay	Weighted overlays, Neighborhood process,	
Graphic Resolution	1024 x 1280 pixels	1024 x 768 pixels	1024 x 768 pixels	
Color	256 + shading	256 + shading	256 + shading	
Output Peripherals	Printer, Plotter, Filmwriter, Typewriter, Video	Printer, Plotter	Printer, Plotter	

APPENDIX B GIS SOFTWARE EVALUATION MATRIX			
QUESTION	VENDOR		
	GEOVISION	ARC/info	ERDAS
Name, Address, and Phone Number	Shannon Moore Geovision Systems Inc., 5251 DTS Parkway, Suite 200 Englewood, Colorado, 80111 (303) 796-8200	Chris McWire Environmental Systems Research Institute Inc 8000 Corporate Ctr Dr, Suite 111 Charlotte, North Carolina, 28226 (704) 541-9810	Irene S.Zeff ERDAS Inc. 2801 Buford Highway Atlanta, Georgia, 30329 (404) 248-9000
GIS Data Storage: Raster or Vector	Both	Both	Both
Operating Hardware	Unix, PC(386)	Unix, PC(386)	Unix, PC(386)
Input Peripherals	Scanner, CD-ROM, Digitizer	Scanner, Digitizer, Video, CD-ROM	Scanner, Digitized, Tapes, CD-ROM
What publically available data files can be translated	DTM, SPOT, TIGER, DIME, Landsat	DLG, SPOT, TIGER, DIME, SIF, DTM DEM, Landsat	DLG, SPOT, DEM, TIF, Landsat
What other GIS can be inputted	Intergraph	GRASS	ARC/info, GRASS, Intergraph
Coordinate System and Data	Flexible	Flexible	Flexible
Is there an upper limit to database	Relational database - hardware limited	Relational database - hardware limited	Tabular - hardware limited
Is there a data layer limit	No limit	999	No limit
Is there a upper limit to data per layer	Relational database - hardware limited	Relational database - hardware limited	Software toolkit available
Toolkit Available	Vision Developer, macro language	Arc macro language	Terrain modeling, 3-D Graphic interface
3-D Analysis	Only "z" value stored	TIN modeling	Overlay analysis, Proximity analysis
Other Analytical Capabilities	Network analysis, Terrain modeler, Polygon analysis, Spatial analysis	Buffer analysis, Network analysis	Buffer analysis, Spatial analysis
Graphic Resolution	1024 x 768 pixels	1024 x 768 pixels	1024 x 768 pixels
Color	256 + shading	256 + shading	256 + shading
Output Peripherals	Printer, Plotter	Printer, Plotter, Post Script	Printer, Plotter, Postscript

APPENDIX B  
GIS SOFTWARE EVALUATION MATRIX

QUESTION	VENDOR		
	GENASYS	ATLAS*GIS	INFOCAD
Name, Address, and Phone Number	Tom Bramble Genasys 2629 Redwing Road, Suite 330 Fort Collins, Colorado, 80526 (303) 226-3283 or 1-800-447-0265	Craig Silverman Strategic Mapping Inc. 4030 Moorpark Ave., Suite 250 San Jose, California, 95117 (408) 970-9600	Harold Jacobs, Sales Representative Digital Matrix Services Inc. 3191 Coral Way, Suite 900 Miami, Florida, 33145 (305) 445-6100
GIS Data Storage: Raster or Vector	Vector based	Vector	Vector based
Operating Hardware	Unix, PC(386)	PC(386)	Unix(HP 700)
Input Peripherals	Scanner, Digitized, CD-ROM	Digitizer, Scanner, CD-ROM	Digitizer, Scanner, CD-ROM
What publically available data files can be translated	DXF, DLG, SIF, TIGER, DIME, DEM, DGN, TIF	TIGER, DIME, DLG	ETAK, TIGER, DIME, MOSS, DXF, IGES, SIF
What other GIS can be inputed	Intergraph	AcInfo	Flexible
Coordinate System and Data	Flexible	Flexible	Flexible
Is there an upper limit to database	Relational database - hardware limited	Relational database - hardware limited	Relational database - hardware limited
Is there a data layer limit	No limit	No limit	No limit
Is there a upper limit to data per layer	Relational database - hardware limited	Relational database - hardware limited	Relational database - hardware limited
Toolkit Available	Interactive customization	Atlas Script	InfoTRAN-FORTRAN and C
3-D Analysis	With 3-D package	"z" value stored	Yes
Other Analytical Capabilities	TIN Modeling, Network analysis Spatial analysis, Grid analysis	Overlay analysis, Buffer analysis Grid analysis, Spatial analysis	Network Analysis, Buffer analysis Spatial analysis, TIN modeling, Overlay an
Graphic Resolution	1024 x 1280	1024 x 768	1024 x 768
Color	256 + shading	256 + shading	256 + shading
Output Peripherals	Printer, Plotter	Printer, Plotter	Printer, Plotter

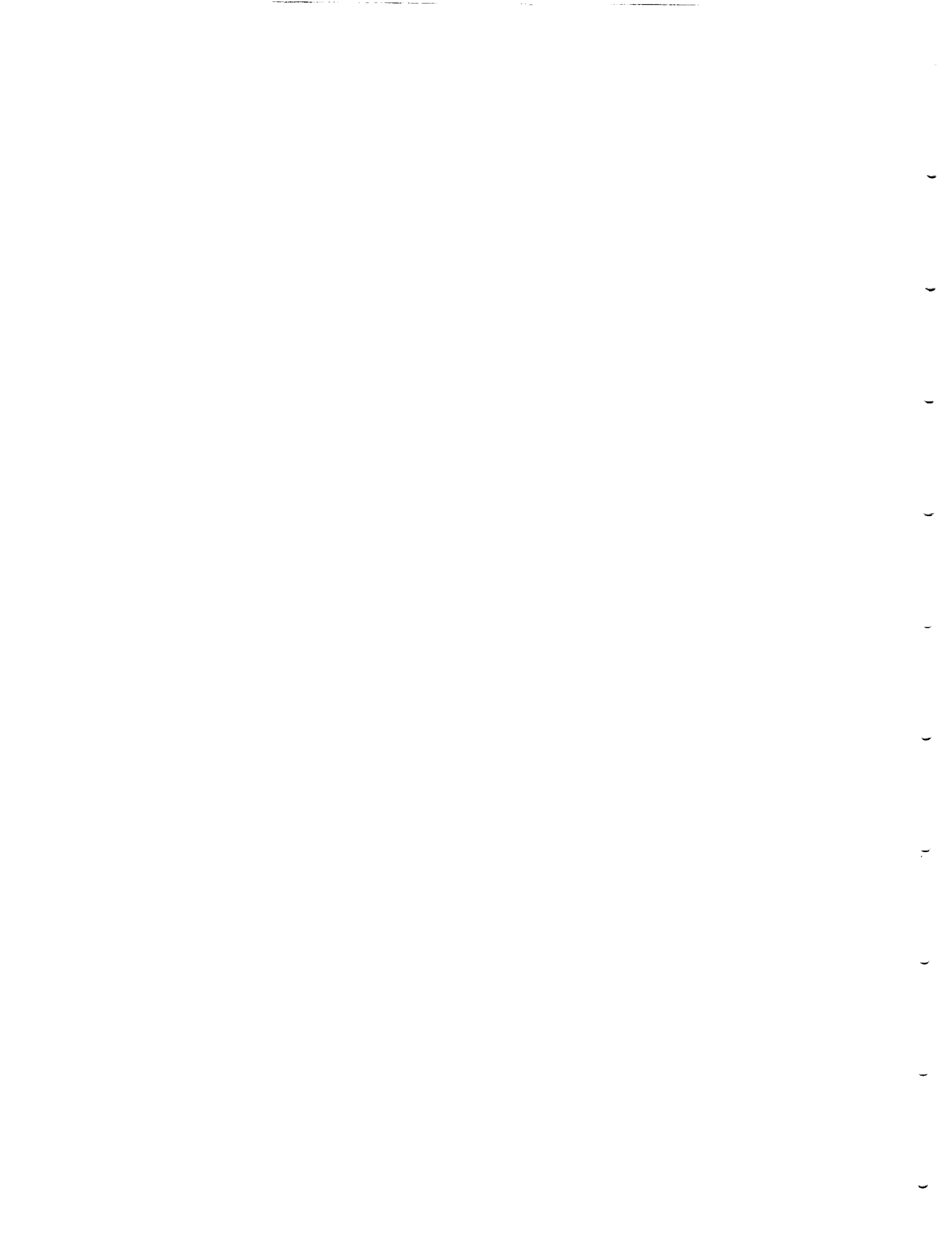

APPENDIX C: INTEGRATED NOISE MODEL (INM) VERSION 3.10

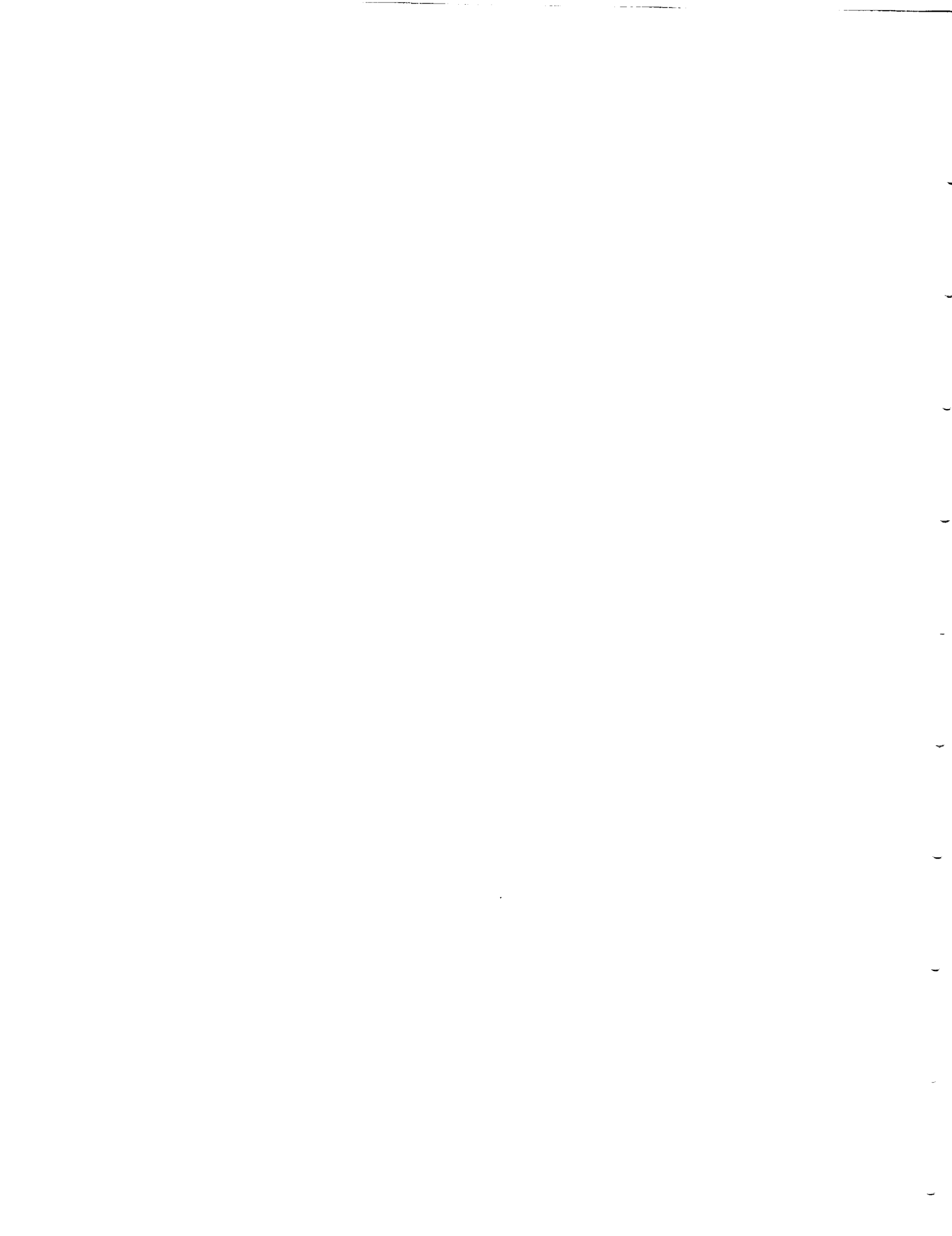



U.S. Department  
of Transportation  
Federal Aviation  
Administration

800 Independence Ave., S.W.  
Washington, D.C. 20581

June 25, 1992

## INTEGRATED NOISE MODEL (INM) VERSION 3.10

The Federal Aviation Administration (FAA) is now offering the new Integrated Noise Model (INM) Database No. 10 to use with INM Version 3. To order, simply fill out and return the attached request form.

The FAA's INM is a set of computer software with a database of aircraft performance and noise to predict aircraft noise in the vicinity of airports. The present standard is INM Version 3.9 which refers to the third version of the source code and the ninth database. Database No. 9, which has been in use since 1987, contains 81 aircraft; each of which has associated noise-power-distance (NPD) tables, one or more takeoff profiles, and approach parameter data. In 1990, through the Transportation Systems Center in Cambridge, Massachusetts, the FAA contracted with Acoustical Analysis Associates, Inc., of Canoga Park, California, to develop a new set of takeoff and approach profiles. At the same time, FAA requested updated performance and NPD data from several of the airframe manufacturers on their newer technology aircraft, such as, the 747-400 and the 'Federal Express' 727's. Database No. 10 is the result of this effort. Some of the salient features of the new database are as follows:

1. Contains 101 aircraft and 67 sets of noise tables as opposed to 81 and 59, respectively in No. 9.
2. 20 new aircraft with new NPD tables.
3. Improved standard takeoff and landing profiles.
4. Improved approach parameters.
5. Retained Database No. 9's aircraft ID numbering. All new aircraft are numbered 82 through 101.
6. Revised User's Guide.

Database No. 10 contains the 101 aircraft shown in Figure 1-1. This new database contains a mixture of new aircraft with new and old NPD tables, and it contains all new performance information. All the new aircraft use either the NPD tables from Database 9 or their own new tables with the exception of aircraft Nos. 93 and 94, which have no noise data. (These data will be supplied when they become available.) Database No. 10 does represent the best available data for a wide variety of aircraft.

Aircraft #	Name	Description	Category Name	Noise #	Name	Apprch #	Takeoff Profiles by Trip Length (nm)							
							0-500	500-1000	1000-1500	1500-2500	2500-3500	3500-4500	over 4500	
1	747100	B747-100/JT90B	JCOM	6	JT90B	1	1	2	3	4	5	6	0	
2	747200	B747-200/JT9D-7	JCOM	7	JT9D FL	2	7	8	9	10	11	12	13	
3	747100	B747-100/JT9D-7GM	JCOM	7	JT9D FL	3	14	15	16	17	18	19	0	
4	747SP	B747SP/JT9D-7	JCOM	7	JT9D FL	4	20	21	22	23	24	25	0	
5	747200	B747-200/JT9D-7G	JCOM	50	JT9D7G	5	27	28	29	30	31	32	26	
6	DC820	DC-8-20/JT4A	JCOM	1	JT4A	6	34	35	36	37	38	39	33	
7	707	B707-120/JT3C	JCOM	1	JT4A	7	40	41	42	43	44	45	0	
8	720	B720/JT3C	JCOM	1	JT4A	8	46	47	48	49	50	0	0	
9	707320	B707-320B/JT3D-7	JCOM	2	JT3D	9	51	52	53	54	55	56	0	
10	707120	B707-120B/JT3D-3	JCOM	2	JT3D	10	58	59	60	61	62	63	57	
11	720B	B720B/JT3D-3	JCOM	2	JT3D	11	64	65	66	67	68	69	0	
12	DC850	DC8-50/JT3D-3B	JCOM	2	JT3D	12	69	70	71	72	73	74	0	
13	DC860	DC8-60/JT3D-7	JCOM	2	JT3D	13	75	76	77	78	79	80	0	
14	DC870	DC8-70/CFM56-2C-5	JCOM	4	CFM562	14	82	83	84	85	86	87	81	
15	BAE146	BAE146-200/ALF502R-5	JCOM	5	ALF502R	15	89	90	91	92	93	94	85	
16	707GM	B707-320B/JT3D-7GM	JCOM	3	JT3D	16	92	93	94	95	96	97	98	
17	DC89W	DC8-60/JT8D-7GM	JCOM	3	JT3D	17	99	100	101	102	103	104	105	
18	CONCOR	CONCORDE/OLY593	JCOM	8	OLY593	18	106	107	108	109	110	111	106	
19	DC1010	DC10-10/CF6-60	JCOM	11	CF660	19	112	113	114	115	116	117	0	
20	DC1030	DC10-30/CF6-50C2	JCOM	11	CF660	20	118	119	120	121	122	123	0	
21	DC1040	DC10-40/JT9D-20	JCOM	11	CF660	21	125	126	127	128	129	130	124	
22	L1011	L1011/RB211-22B	JCOM	12	RB2112	22	132	133	134	135	136	137	131	
23	L1011S	L1011-500/RB211-224B	JCOM	12	RB2112	23	138	139	140	141	142	143	0	
24	727200	B727-200/JT8D-7	JCOM	9	JT8D	24	145	146	147	148	0	0	144	
25	727100	B727-100/JT8D-7	JCOM	9	JT8D	25	149	150	151	152	0	0	0	
26	727015	B727-200/JT8D-15	JCOM	9	JT8D	26	153	154	155	156	157	0	0	
27	72709	B727-200/JT8D-9	JCOM	10	JT8D	27	158	159	160	161	0	0	0	
28	72707	B727-100/JT8D-7GM	JCOM	10	JT8D	28	162	163	164	165	0	0	0	
29	727015	B727-200/JT8D-15GM	JCOM	10	JT8D	29	166	167	168	169	170	0	0	
30	727017	B727-200/JT8D-17	JCOM	10	JT8D	30	171	172	173	174	0	0	0	
31	A300	A300B4-200/CF6-50C2	JCOM	19	2CF650	31	175	176	177	178	179	0	0	
32	767CF6	B767-200/CF6-80A	JCOM	60	2CF680	32	180	181	182	183	184	185	186	
33	767JT9	B767-200/JT9D-7R4D	JCOM	60	2CF680	33	187	188	189	190	191	192	193	
34	A310	A310-300/CF6-80C2A2	JCOM	19	2CF650	34	194	195	196	197	198	199	0	
35	737300	B737-300/CFM56-3B-1	JCOM	49	CFM563	35	200	201	202	203	0	0	0	
36	737382	B737-300/CFM56-3B-2	JCOM	49	CFM563	36	204	205	206	207	0	0	0	
37	BAC111	BAC111/SPEY MGS11-14	JCOM	13	2JT8D	37	208	209	210	0	0	0	0	
38	F28M2	F28-2000/RB183MCS55	JCOM	56	RB183	38	211	212	0	0	0	0	0	
39	F28M4	F28-4000/RB183MCS55	JCOM	57	RB183P	39	213	214	215	0	0	0	0	
40	DC930	DC9-30/JT8D-9	JCOM	13	2JT8D	40	216	217	218	0	0	0	0	
41	DC910	DC9-10/JT8D-7	JCOM	13	2JT8D	41	219	220	221	0	0	0	0	
42	737	B737/JT8D-9	JCOM	13	2JT8D	42	222	223	224	225	0	0	0	
43	DC909	DC9-30/JT8D-9GM	JCOM	14	2JT8D	43	226	227	228	0	0	0	0	
44	DC907	DC9-10/JT8D-7GM	JCOM	14	2JT8D	44	229	230	231	0	0	0	0	
45	737GM	B737/JT8D-9GM	JCOM	14	2JT8D	45	232	233	234	235	0	0	0	
46	DC950	DC9-50/JT8D-17	JCOM	14	2JT8D	46	236	237	238	0	0	0	0	
47	737D17	B737-200/JT8D-17	JCOM	14	2JT8D	47	239	240	241	242	0	0	0	
48	M81	MD-81/JT8D-209	JCOM	54	2JT8D2	48	243	244	245	0	0	0	0	
49	M82	MD-82/JT8D-217A	JCOM	54	2JT8D2	49	246	247	248	249	0	0	0	
50	M83	MD-83/JT8D-219	JCOM	54	2JT8D2	50	250	251	252	253	0	0	0	
51	757LR	B757-200/RB211-535E4	JCOM	52	RB535E	51	254	255	256	257	258	0	0	
52	757PW	B757-200/PW2037	JCOM	53	PW2037	52	259	260	261	262	263	264	0	
53	COMJET	1985 BUSINESS JET	JGA	21	CGAJ	53	265	0	0	0	0	0	0	
54	LEAR35	LEAR 36/TF731-2	JGA	23	TF7312	54	266	0	0	0	0	0	0	
55	LEAR25	LEAR 25/CJ610-8	JGA	22	CJ610	55	267	0	0	0	0	0	0	

FIGURE 1-1.



APPENDIX D: ELEVATION USE DATA BASES

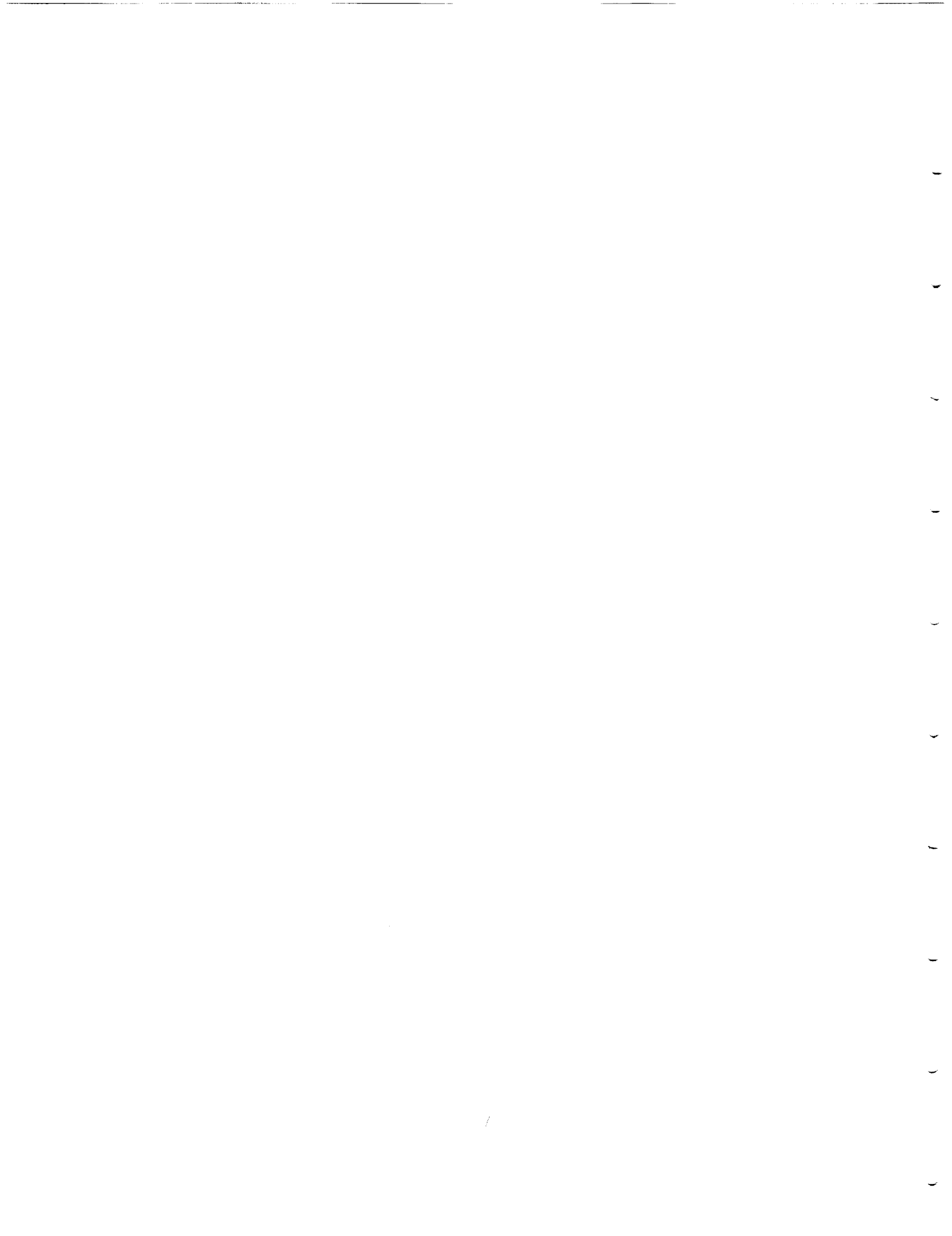

## Digital Elevation Models (DEM's):

DEM's are digital cartographic representations of the surface of the earth or a subsurface feature represented through a series of three-dimensional coordinate values. They are digital records of terrain elevations for ground positions at regularly spaced intervals. In digital form, terrain elevations can be valuable for regional terrain modeling, determining the direction of slope, land use studies and air routing. US geographical data tapes for terrain elevations are available, for United States indifferent formats, from the NCIC in Washington, D.C.

One such format is the USGS 7.5 minute digital elevation model data. This isometric illustration is of the Little Bigelow Mountain area in Maine. These data are available in 7.5 minute blocks which correspond to USGS topographic quadrangle maps. Each DEM, like each topographic quadrangle, covers approximately 60 square miles. The ground distance between each digitized point is 30 meters.

The second format available from NCIC is DMA DEM data. These data are available in 1 degree by 1 degree block format. Two of these blocks are required to cover each 1 degree by 2 degree map (1:250,000 scale quadrangle) from which the data were produced. The ground distance between each digitized point is 3 arc-seconds.

## Digital Terrain Elevation Data Level 1 (DTED 1)

DTED 1 produced by the Defense Mapping Agency contains a uniform matrix uniform matrix of terrain elevation values (Figure D.1). These plots can be presented from both an oblique and vertical perspective. The elevation data can be depicted using a profile or contour plot. This elevation model provides basic quantitative data for all systems that require terrain elevation, slope, and/or surface roughness information system. Each cell offers identification, administrative data, and information required for the application, maintenance, and verification of the elevation values.

## World Mean Elevation Data (WMED)

The World mean elevation data consists of minimum, maximum, and mean terrain elevations for all areas throughout the world. Elevation data, depicted in meters, are collected for World Area Grid (WAG) cells - (the standard unit for WMED depiction) for all land masses. The preferred source for this is the DTED. In areas with no DTED coverage, a small scale cartographic source is used. Data for each cell include minimum elevation value (low), maximum elevation value (high), arithmetic mean elevation, standard deviation, source, and absolute vertical accuracy.

# DMA DTED LEVEL I DATA OVER MOUNTAINOUS TERRAIN

## Profile Plot

Elevations depicted as profile lines from an oblique perspective.

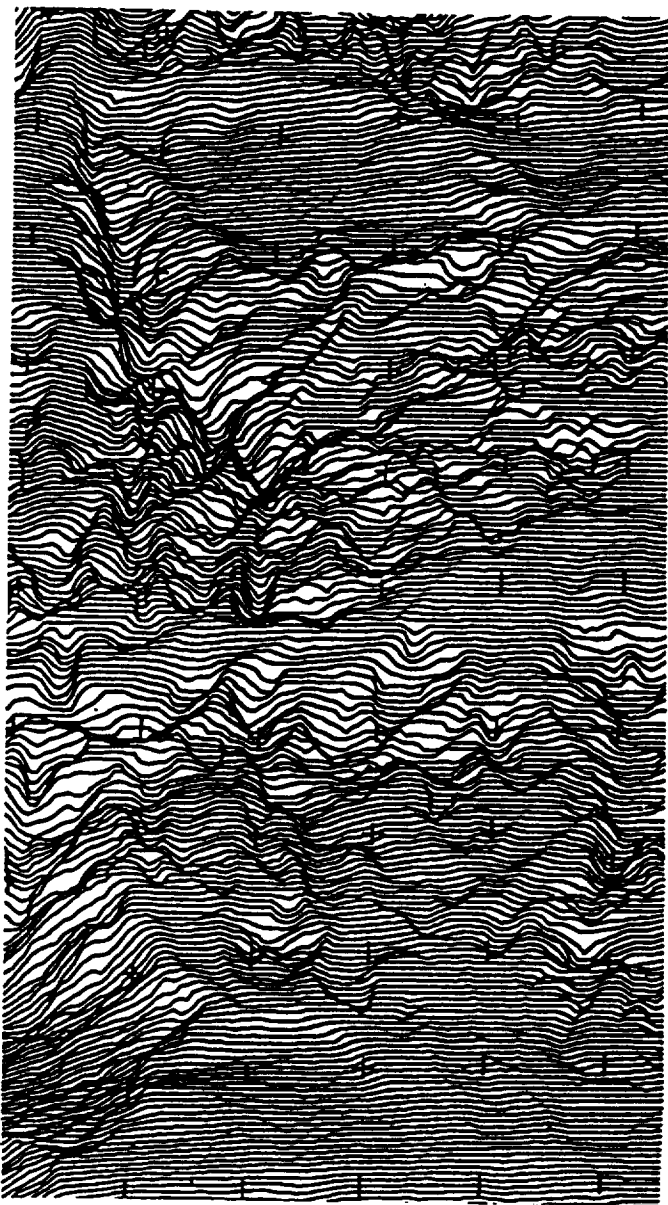

**DTED Level I  
Profiles**

## Contour Plot

Elevations depicted as contour lines from a vertical perspective.

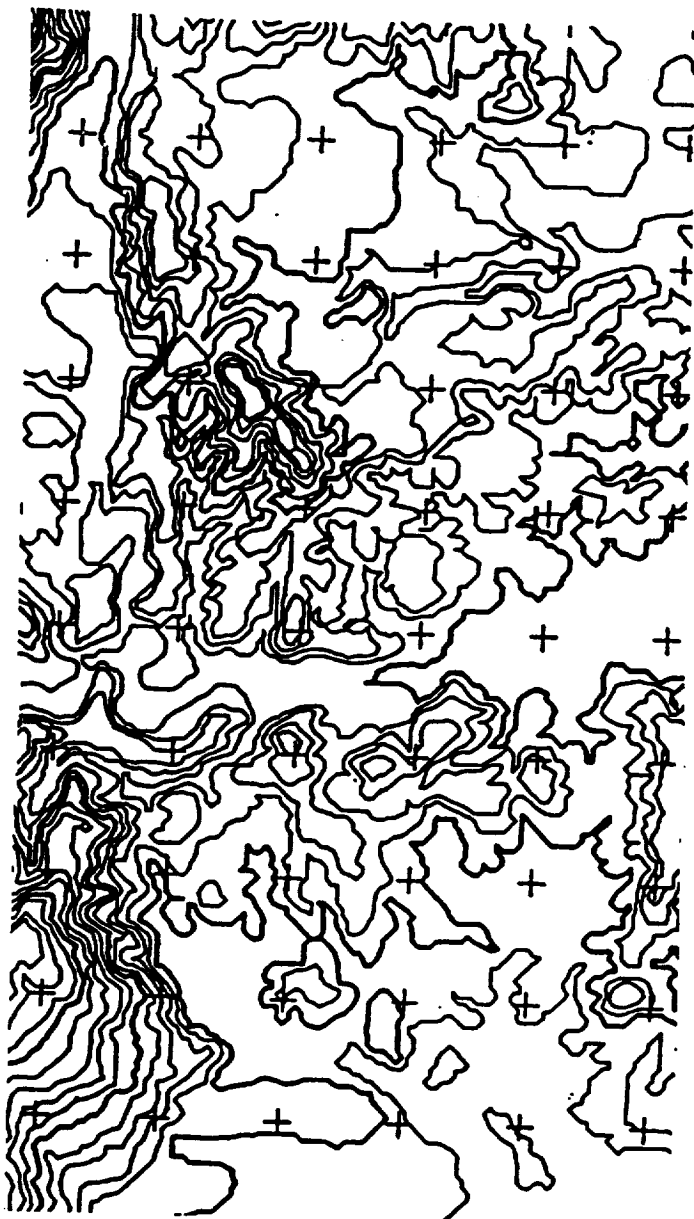

**DTED Level I  
Contours**

Figure D.1 Digital Terrain Elevation Data (DTED).

APPENDIX E: LAND USE DATA BASES

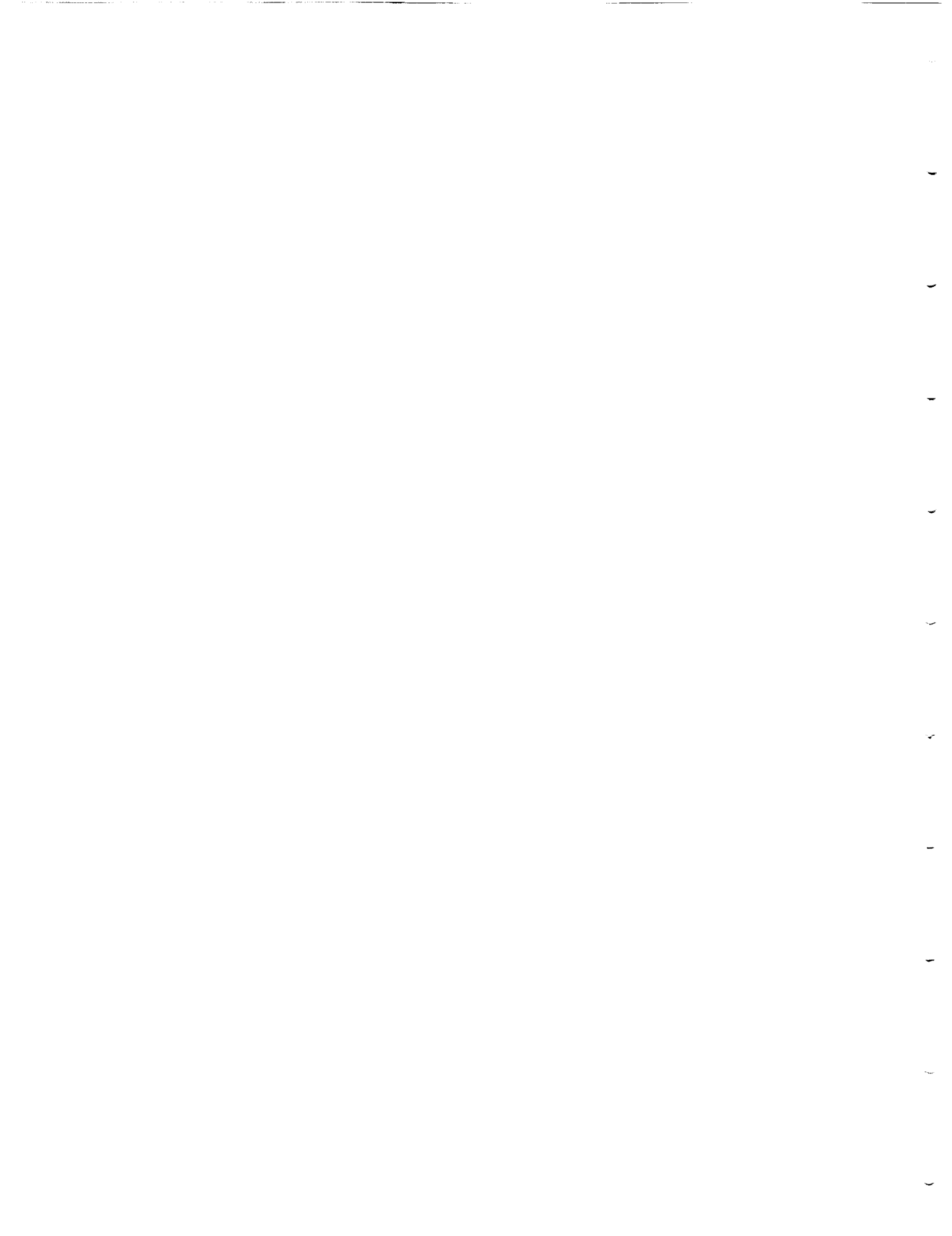

## Land Use and Land Cover (LULC) and Associated Maps Digital Data

LULC digital data (the representation of cartographic features in a form that allows the values of their attributes to be stored, manipulated, and output by a computer system) are derived from thematic overlays (the overlays that display data related to a specific topic such as airport sites represented by dot-density, contour etc.) prepared at a map scale of 1:250,000 and 1:100,000 scale base maps.

The overall goal was to cover all the areas in United States, but under the present conditions they are far from reaching that goal. LULC digital data available in the form of computer tapes provide information on urban or built up land, agricultural land, range land, forest land, water, wetland, barren tundra and perennial snow or ice. Associated maps display information on political units, hydrological units, Federal land ownership and census county subdivisions. Each major class is composed of several minor classes. For example, forest lands are further classified as deciduous, evergreen or mixed forest land. These categories of land use information are not as refined as those for specific political jurisdictions, which delineate all categories of land related to the comprehensive land use plan and zoning ordinances.

LULC and associated maps are polygons (an enclosed geographic area such as land parcel or political jurisdiction), or aerial maps. Each polygon is identified with an attribute code describing the area. When the map information is digitized, it is processed through the Geographic Information Retrieval and Analysis System (GIRAS). They are available in two formats, one being the vector polygon format and the other being composite theme grid cell format.

LULC and associated maps are in the Universal Transverse Mercator (UTM) Coordinate System (a map projection and plane coordinate system based on sixty north-south trending zones, each 16 degrees of longitude wide, that circle the globe). With these data, one can rotate and translate the coordinate system and scale it to the size they desire. One can also transform the data to other map projections by converting to geographic coordinates and relating geographic coordinates to their specified map projection.

## Digital Planimetric Data

Digital Planimetric data are the digital form of physical features and other physical entities located on the land as shown in Figure E.1. As a first step in providing 1:100,000 scale digital cartographic data for the United States, the USGS has produced 1:100,000 scale Digital Line Graphs (DLG's) consisting of planimetric data from USGS 1:100,000 quadrangles for all of the area in United States. At present, the topologically structured (a geographic data structure in which the inherent spatial connectivity and adjacency relationships of features are implicitly stored and maintained) 1:100,000 scale DLG's include planimetric data on three categories namely hydrography, transportation,

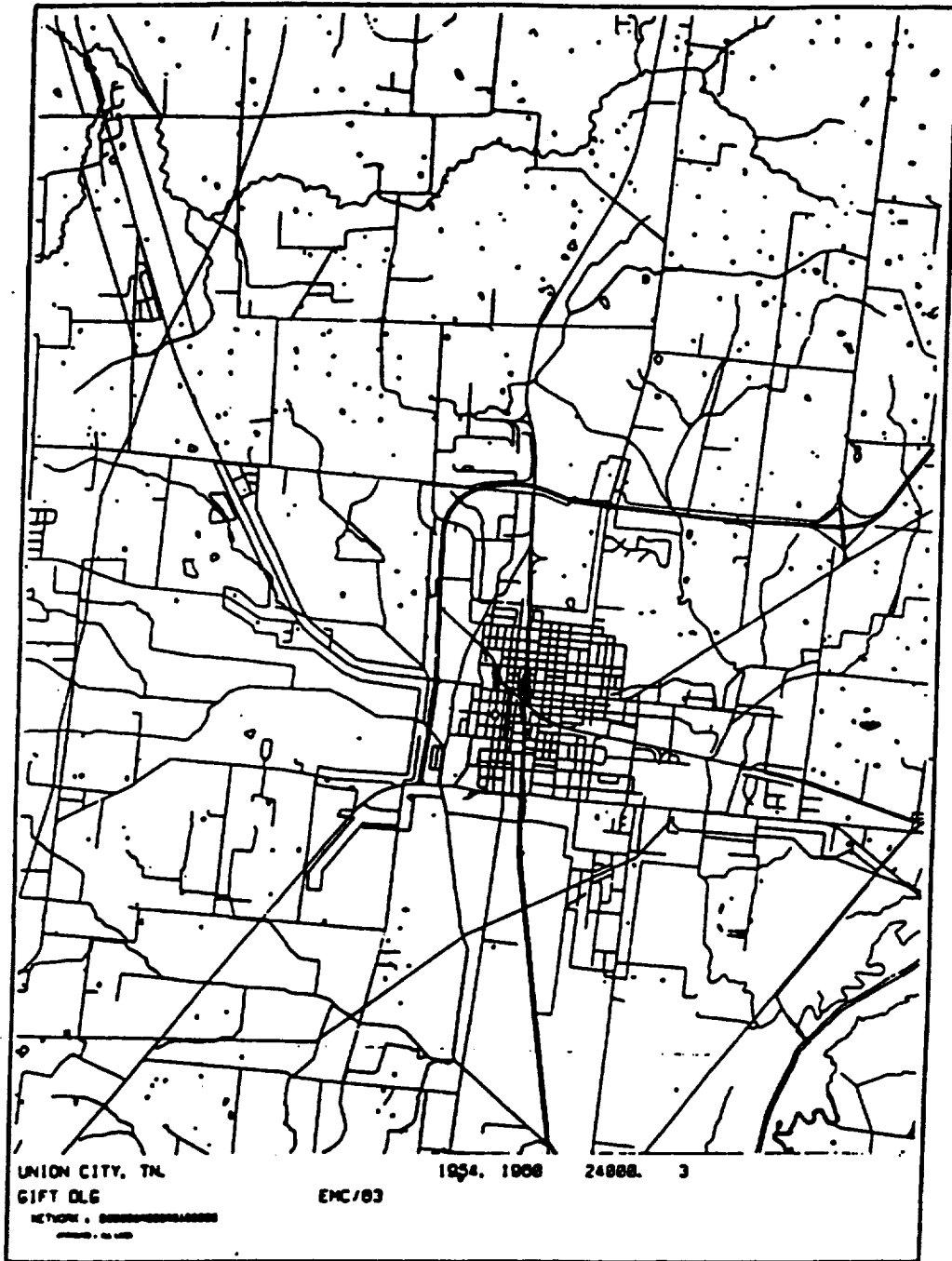

Figure E.1 Digital planimetric data.



boundaries and U.S. public land survey system (Figure E.2).

1. Hydrographic data consists of
  - flowing water
  - standing water
  - wetlands
2. Transportation data consists of
  - roads and trails
  - railroads
  - pipelines, transmission lines
  - airports
3. Boundaries
  - state and county boundaries
  - federally administered lands (National Forests, National Parks, etc.).

The 1:100,000 scale DLG's are available in two formats. The standard format has an internal file coordinate system. The optional format has already been converted to UTM Coordinates.

#### Digital Feature Analysis Data (DFAD)

The DFAD data base consists of selected natural and manmade planimetric features classified as point, line or area features as a function of their size and composition (Figure E.3). Each feature is assigned an identification code and further described in terms of composition, height, length, and orientation. It includes information on lines of communications (roads/rails), vegetation, drainage, urban areas, prominent buildings, power lines, towers, etc.

They are available in four forms, namely DFAD Level 1, DFAD Level 1c, DFAD Level 2, and DFAD Level 3c. Both in DFAD Level 1 and DFAD Level 1c the data are stored in vector format (a format for processing and displaying graphic data. Vector data are represented by strings of coordinates representing the true position of features represented by points, areas, and their boundaries) and segregated into 1 degree by 1 degree geographic cells. The feature density of DFAD level 1c is generally less than DFAD level 1. DFAD level 2 and DFAD 3c are more detailed than DFAD level 1. Both are typically stored in variable patch sizes ranging from 2x2 nm to 3.75x3.75 nm.

#### Interim Terrain Data (ITD)

Interim Terrain Data consists of contiguous digital data sets covering specified geographic areas. These data sets are composed of attributed (a type of non-graphic data that describes the entities represented by graphic elements) and un-symbolized feature information equivalent to the content of either Tactical Terrain Analysis Data bases (TTADB's) or Planning Terrain Analysis Data Bases (PTADB's), and an enhanced

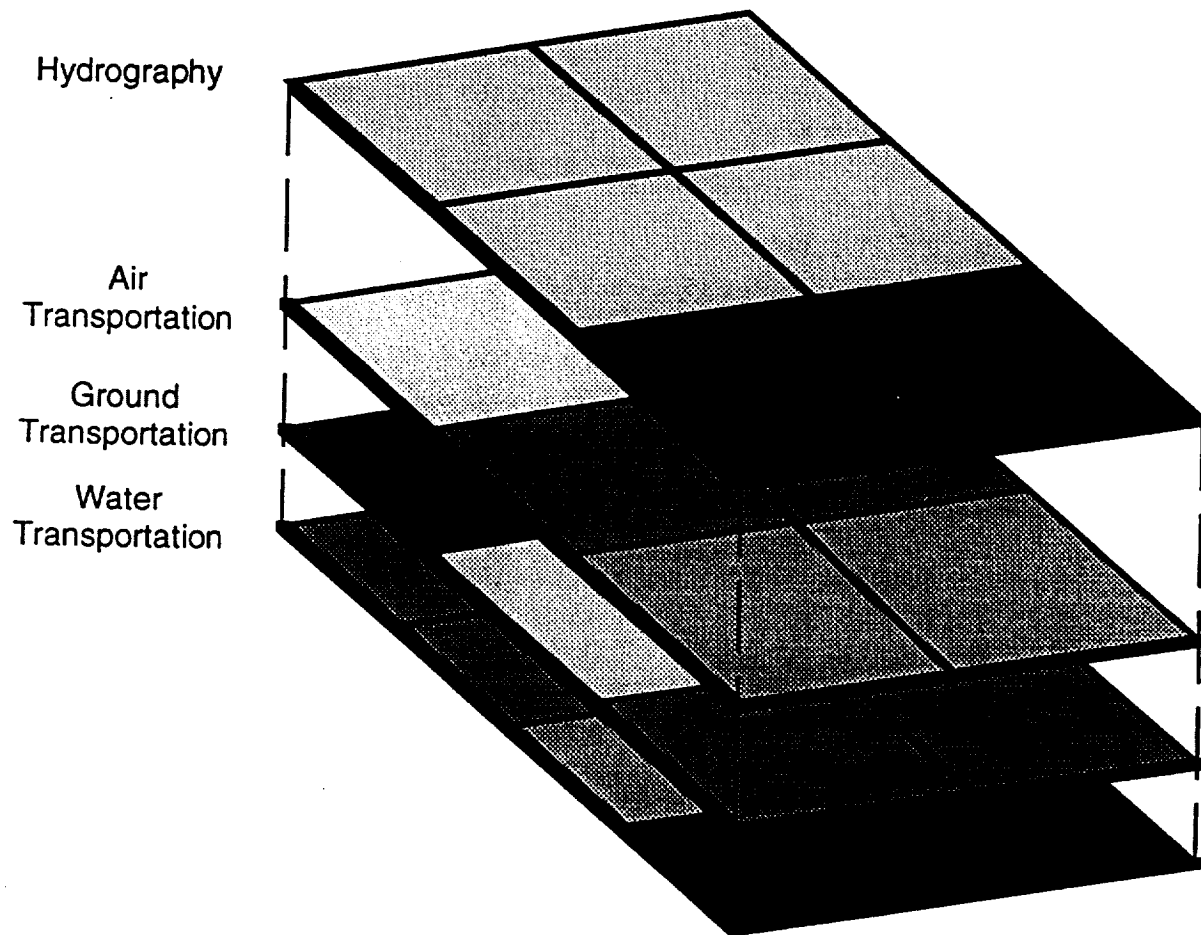

Figure E.2 Organization of overlays and files for the digital line graphs (DLG's).

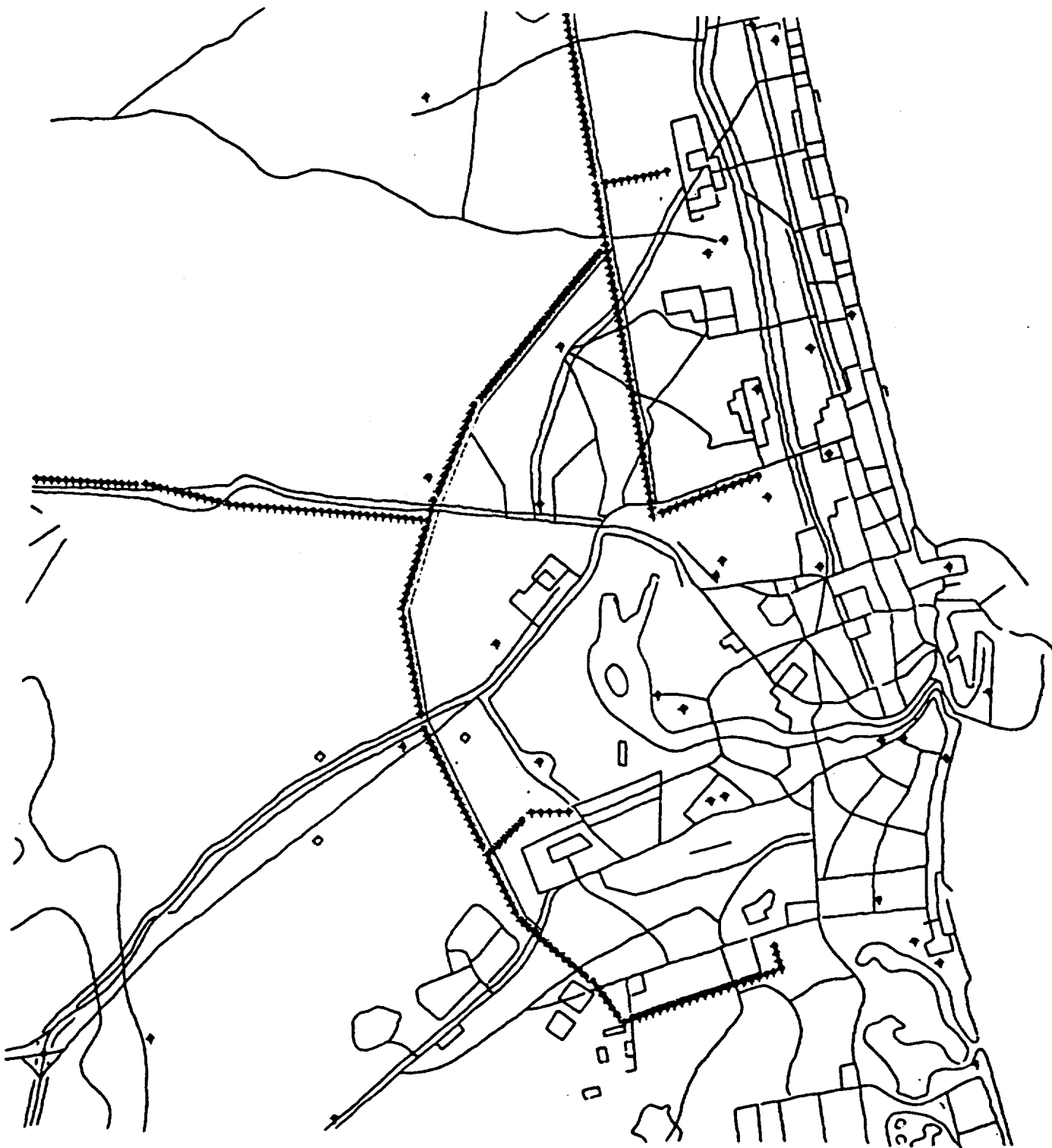

Figure E.3 Digital feature analysis data (DFAD).

transportation file (Figure E.4). ITD is used in conjunction with DTED 1. It consists of feature data in seven segregated files: surface configuration (slope), vegetation, surface materials, surface drainage, transportation, obstacles, and DTED 1.

#### Tactical Terrain Data (TTD)

Tactical Terrain Data contains three dimensional feature data and are more detailed than ITD. The elevation data are the elevations of the features. Each three-dimensional TTD cell will be accompanied by elevation data at a resolution appropriate to the terrain. Feature data are topologically structured and provide an enhanced version of TTD base thematic overlays with selected features consistent with 1:50,000 scale topographic line maps.

**Vegetation**



**Transportation**

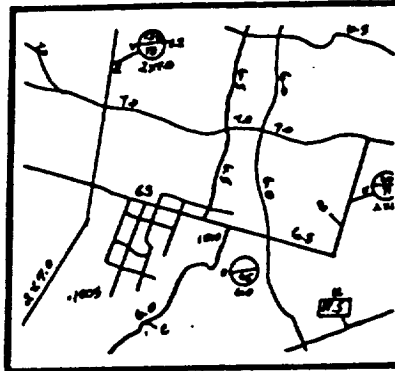

**Surface Materials**

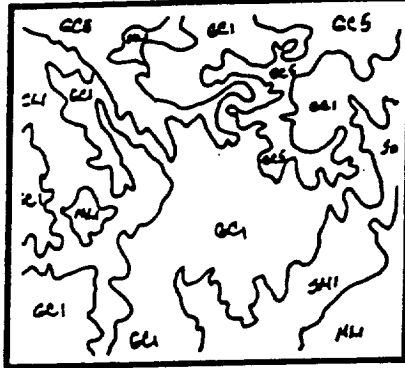

**Surface Drainage**

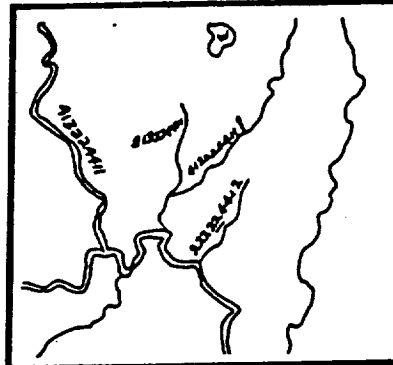

**Surface Configuration**



**Obstacles**

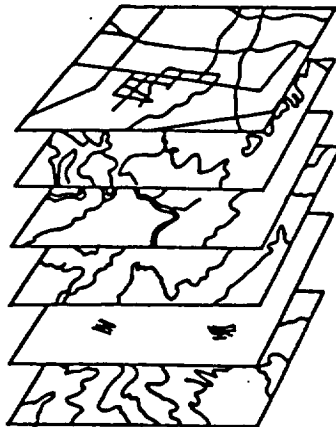
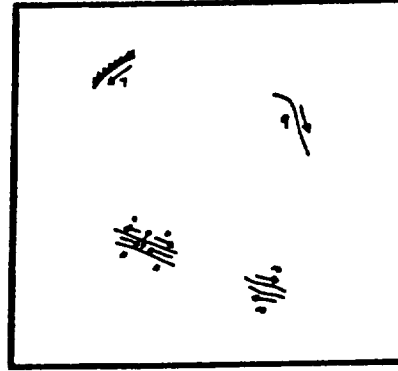

**Composite of Overlays**

Figure E.4 Interim terrain data (ITD).

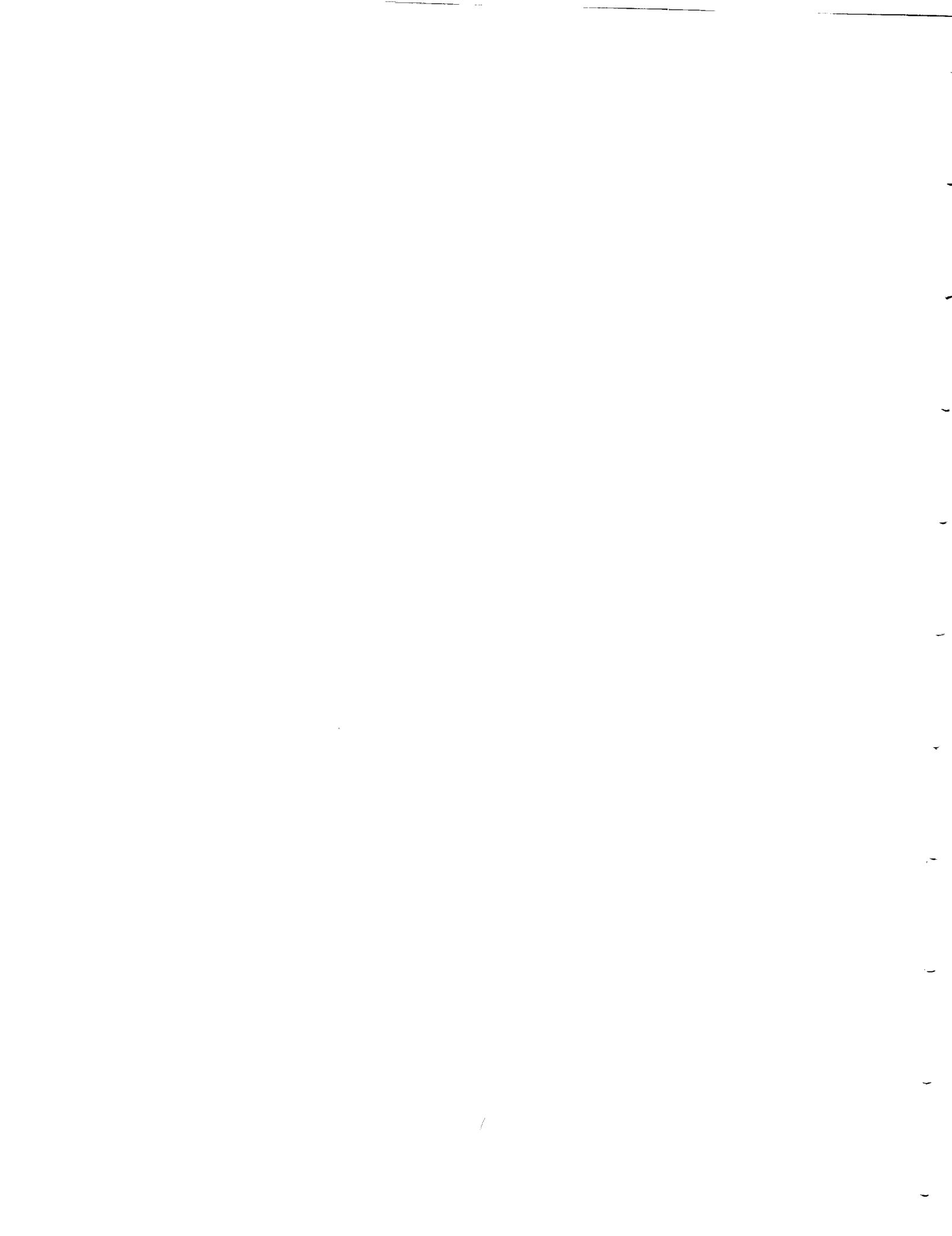

APPENDIX F: SOIL DATA BASES

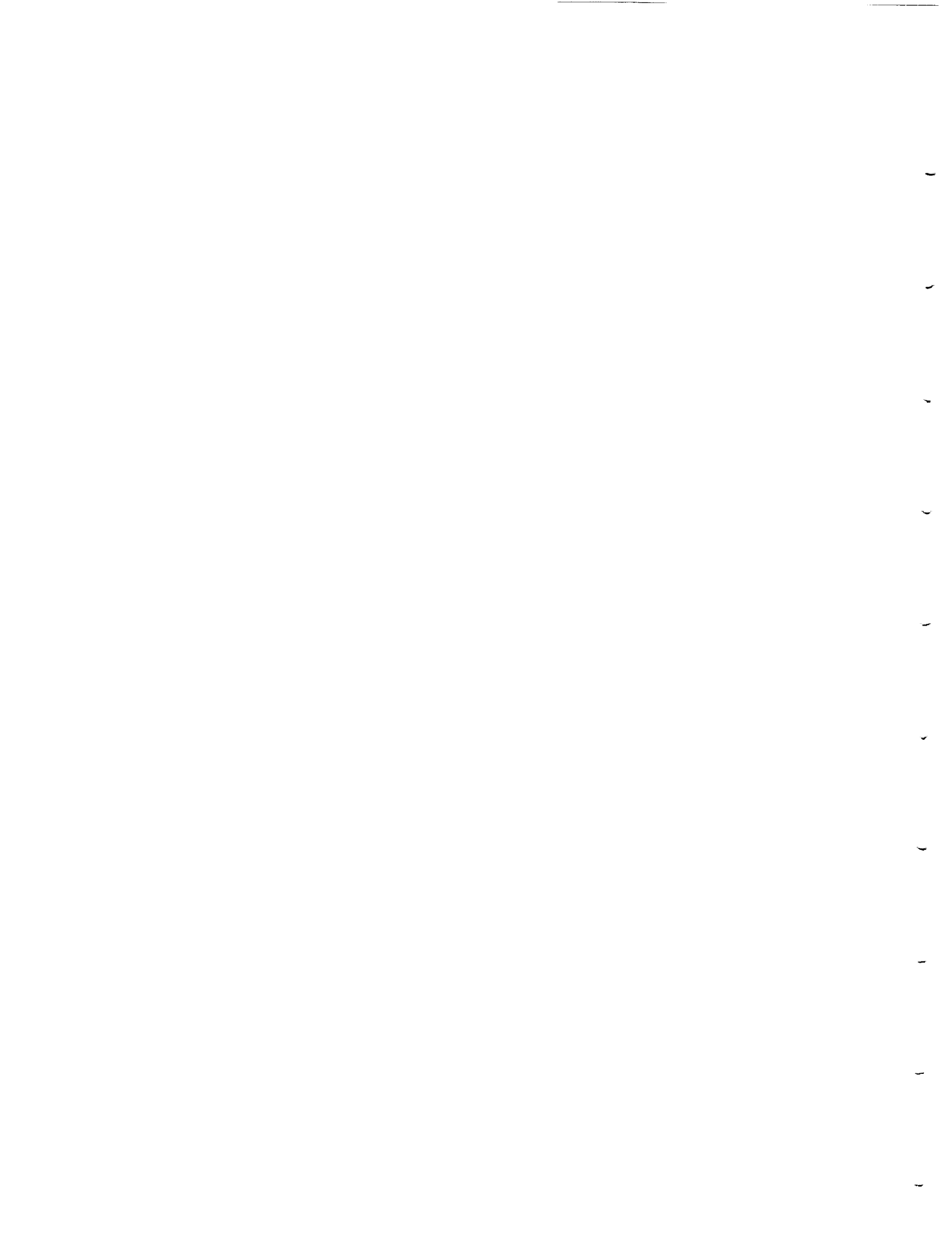



### SSURGO Data Base

SSURGO, the most detailed level of information, is used primarily for resource planning and management at the county, parish and township level. Utilizing the soil attributes, this data also serves as an excellent source to review site development proposals and land use potential to make land use assessments and to identify potential wetland areas.

### STATSGO Data Base

STATSGO is used primarily at the state level for river basin, and multi-county resource planning, management and monitoring. Soil maps for STATSGO are made by generalizing more detailed soil survey maps. Where more detailed maps are not available, data on geology, topography, vegetation, and climate are assembled, together with Landsat images provided by NASA. Soils of analogous areas are studied, and a determination of the probable classification and extent of the soils is made.

### NATSGO Data Base

NATSGO is used primarily for national, regional, and multi-state resource appraisal, planning, and monitoring. The boundaries of the major land resource area (MLRA) and land resource regions were used to form the NATSGO data base. The MLRA boundaries were primarily developed from state general soil maps.

SSURGO, STATGO and NATSGO spatial data are distributed from National Cartographic Center (NCC) in either the USGS Digital line graph (DLG-3) Optional Distribution Format or the SCS Geographic Exchange Format (SCS-GEF).

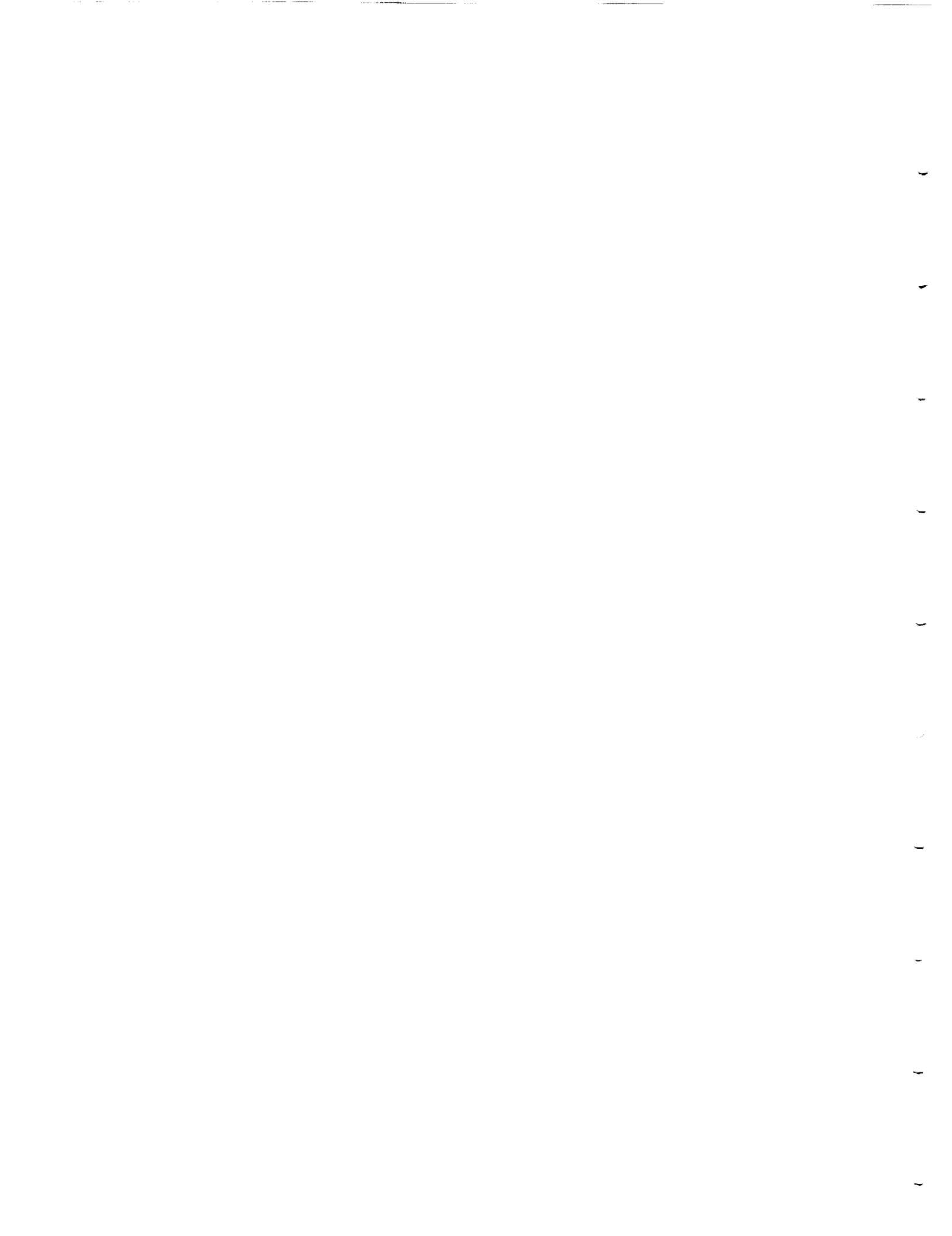

**APPENDIX G: ANCILLARY DATA BASES OF SPECIALIZED INFORMATION**

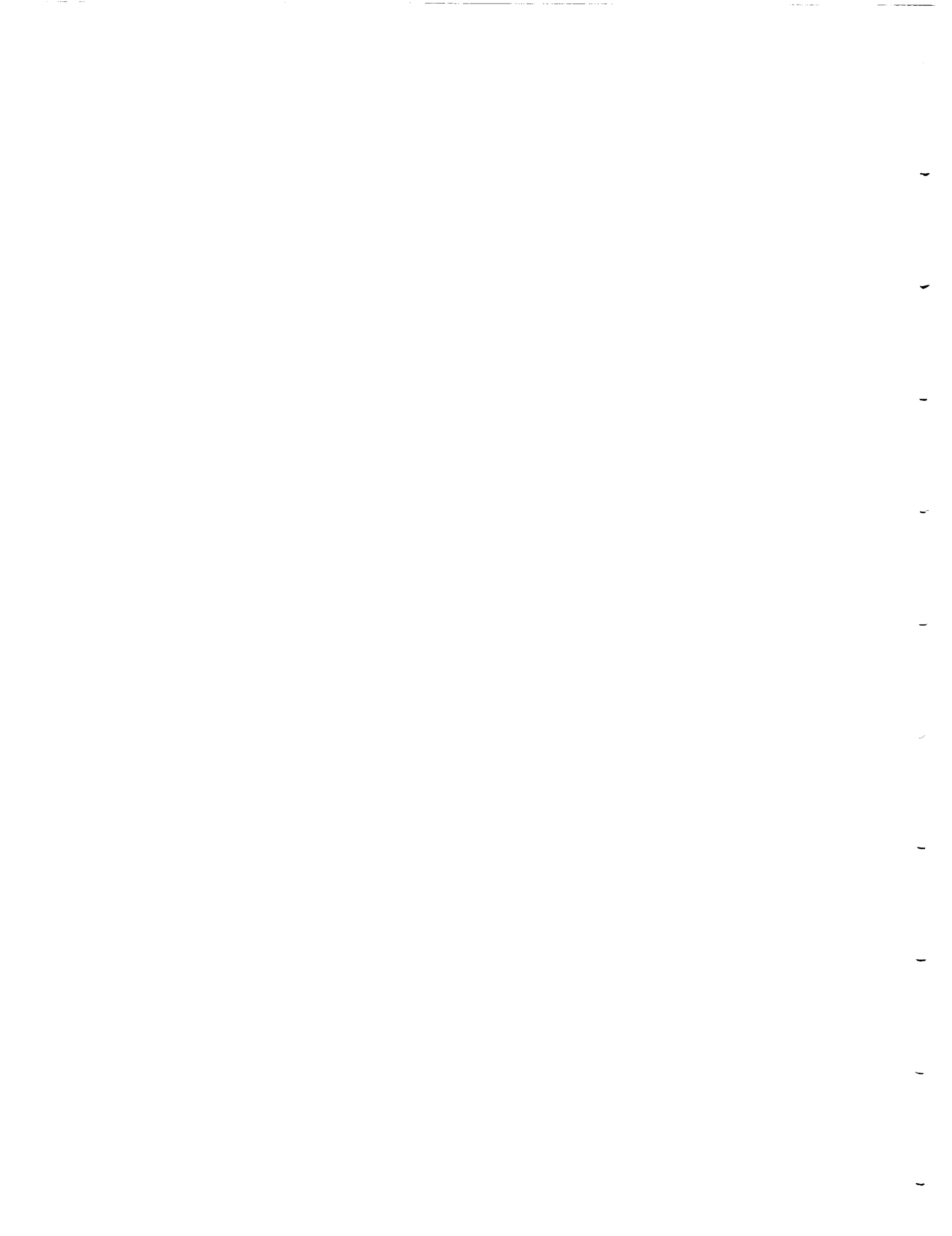

## Geographic Names Information Data Base

The Geographic Names Information System (GNIS), available from USGS, is an automated data system developed by the USGS to standardize and disseminate information on geographic names. GNIS provides primary information for all known places, features and areas in the United States identified by a proper name. GNIS is composed of three separate data bases. Each of these databases provide different, but related information for names in the 50 states, the District of Columbia, and the territories and outlying areas of the United States.

### National Geographic Names Data base (NGNDB)

The NGNDB is the primary, and by far the largest, data base in GNIS. This database contains computerized records on almost two million geographic feature names in the United States - populated places, schools, parks, airports, etc. The information in the NGNDB is useful in locating manmade and natural features (Figure E.1). For example, if one wants to know where Atlanta Hartsfield Airport is located, the data base can quickly provide the county and geographic coordinates.

### Topographic Map Names Data Base (TMNDB)

The TMNDB is the official digital inventory of past and present topographic maps published by the Geological survey. The data base is presently organized into five files representing individual map series. Standard reports produced from the file include the official map name, geographic coordinates, the first 8 characters of the code developed by the survey that uniquely identifies each map, the map publication date, and five digit FIPS code(s) referring the state(s) and county(s) for which the map portrays.

### Reference Data Base

The reference data base is organized into two files. The Generic Reference File contains an entry for every feature type Generic term encountered in compilation of the NGNDB (for example, river, mountain, AIRPORT). The Bibliographic Reference File houses the annotated bibliographies of all source materials used in compilation of the NGNDB.

### Probabilistic Vertical Obstruction Data (PVOD)

Probabilistic vertical obstruction data is a file which contains discrete (man-made and natural) vertical obstruction information extracted from Vertical Obstruction Data (VOD), DFAD, the DMA Digital Vertical Obstruction File (DVOF), Power Line Data, Digital Cities Data, and intelligence data bases. Vertical obstructions (VO) include such man-made objects as radio towers, smokestacks, bridges, and power lines.

Each cell in the vertical obstructions file contains a data block header record which

provides identification data, administrative data, and information required for the application, maintenance, and verification of the obstruction records, such as:

1. Obstruction category
2. Location of the obstruction
3. Obstruction height above the terrain
4. Horizontal dimensions of the obstruction
5. Vertical obstruction identification code

Each cell provides information for subregions within the one degree cell for determination of the probability of additional vertical obstructions not captured in the VO File.

Application:

The vertical obstruction information provided by this file can be used for planning air routes, and to set mean clearance heights. They also can be applied in siting airports especially at lower levels.

Automated Air Facilities Information File (AAFIF)

Automated air facilities information file is an automated text file containing evaluated information on facilities, support equipment, services, operations, nav aids/communications, transportation, climatology, and other items for approximately 43,000 air facilities worldwide (Figure G.1). Air facilities are classified by runway length. Seventy-nine subcategories of information are maintained for major air facilities (those with over 2,000 feet usable runway length), and fifty-one subcategories are maintained for minor air facilities.

Application:

Detailed information provided by this file on air facilities, support equipment, services, operations, nav aids/communication, and climatology proves vital in route selection and in siting airports.

Digital Aeronautical Flight Information File (DAFIF)

Digital automatic flight information file is a flight information data base containing airport, runway, navigational aid, and enroute data. The data base includes both the high altitude (18,000 feet and above) and the low altitude (below 18,000 feet) flight corridors. The records include:

1. Airport records, which contain geographic locations and other information for Instrument Flight Rules (IFR) airports.
2. Runway records, which contain specifications for hard-surface runways 3,000 feet or longer.

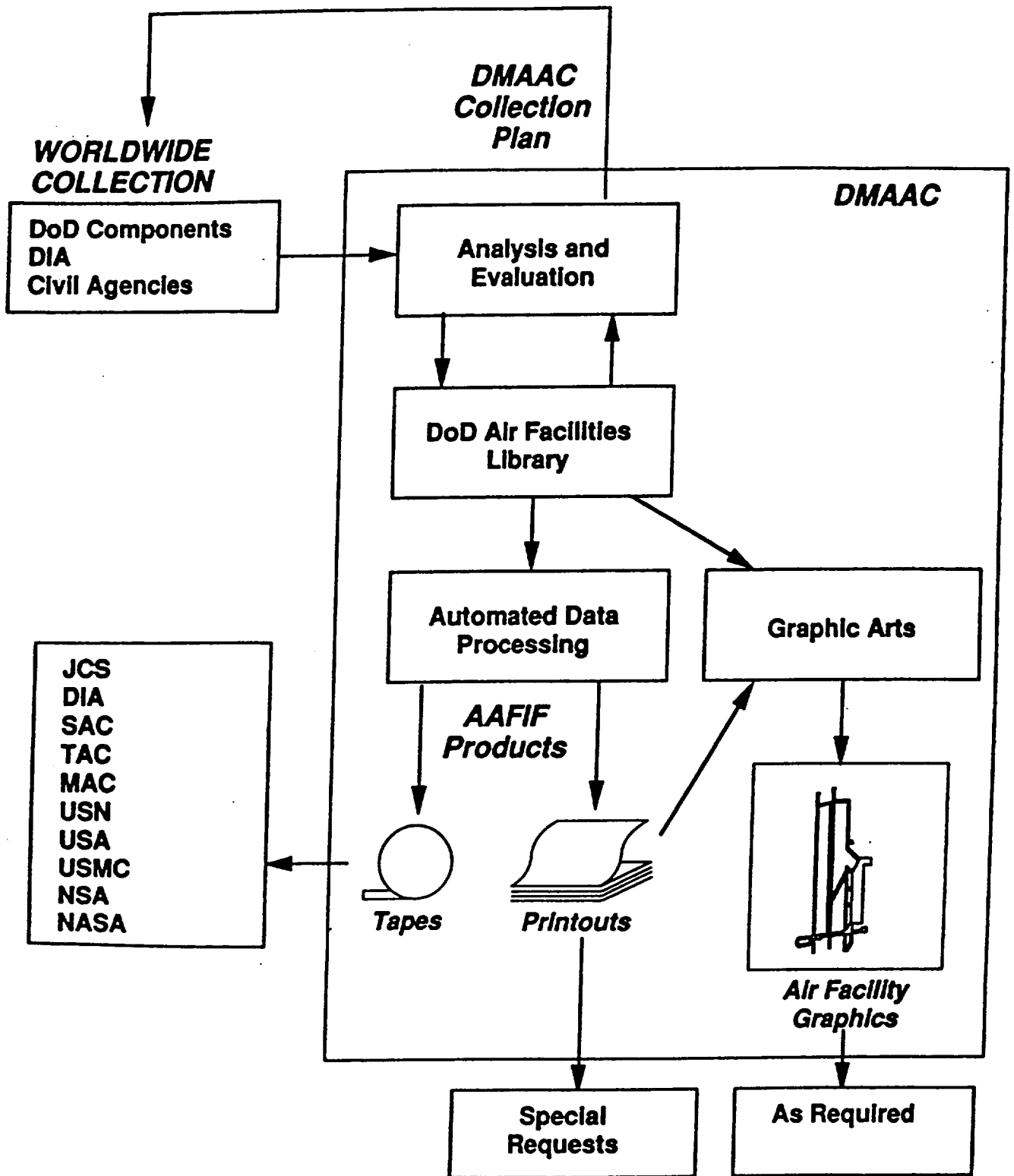

Figure G.1 Automated air facilities information file (AAFIF).

3. Arresting gear records for the above runways.
4. Enroute records, which contain information on high altitude enroute airways and their associated way points.
5. Airspace boundary records, which contain information on airspace of defined dimensions within which flight information service and alerting service are provided.
6. Navigational aid (NAVID) records, which contain information on LF/MF and VHF/UHF facilities.

Application:

The information on airport, runway, navigational aid, and airspace boundary records would be very useful in providing air safety, air route selection, and in airport siting.

Electronic Chart Updating Manual (ECHUM)

The DMA Aeronautical Chart Updating Manual (CHUM) is a semi-annual hard copy publication containing a complete list of published charts for each chart series selected and a list of known corrections. The ECHUM will contain the same information as the CHUM but the information will be accessible from a magnetic tape, CD-ROM or other media. ECHUM will include chart series, chart name, edition number, aeronautical information currency data, and corrections for the available charts in a given series.

Application:

An ECHUM will be used for manual or automated amendment of selected aeronautical charts with updated or corrected information pertaining to safety of Air Navigation. ECHUM information in digital form will enable dial-up receipt of data over a communication network similar to NAVINFONET and direct distribution to users on magnetic/optical media for automated correction of charts and electronically displayed chart images.

Multispectral Imagery (MSI)

Two or more coincident images simultaneously collected in different colors or parts of the electromagnetic spectrum is defined as Multispectral Imagery. The most significant characteristic is its multispectral and color presentation capability. MSI is acquired from satellites distributed by commercial firms (Earth Observation Satellite (EOSAT)). The resolution of the products depends on the satellite and the sensor. Landsat Thematic Mapper (TM) data has a spatial resolution of 30 meters. Landsat Multispectral Scanner (MSS) data has approximately 79 meters spatial resolution. SPOT has 20 meters spatial resolution or 10 meters spatial resolution with a panchromatic sensor.



Application:

Cartographic applications which have been identified include:

1. Satellite image mapping
2. Land cover feature extraction
3. Elevation data extraction

Air crews using natural color perspective views created by "draping" the imagery over DTED finds MSI to be of greater use.

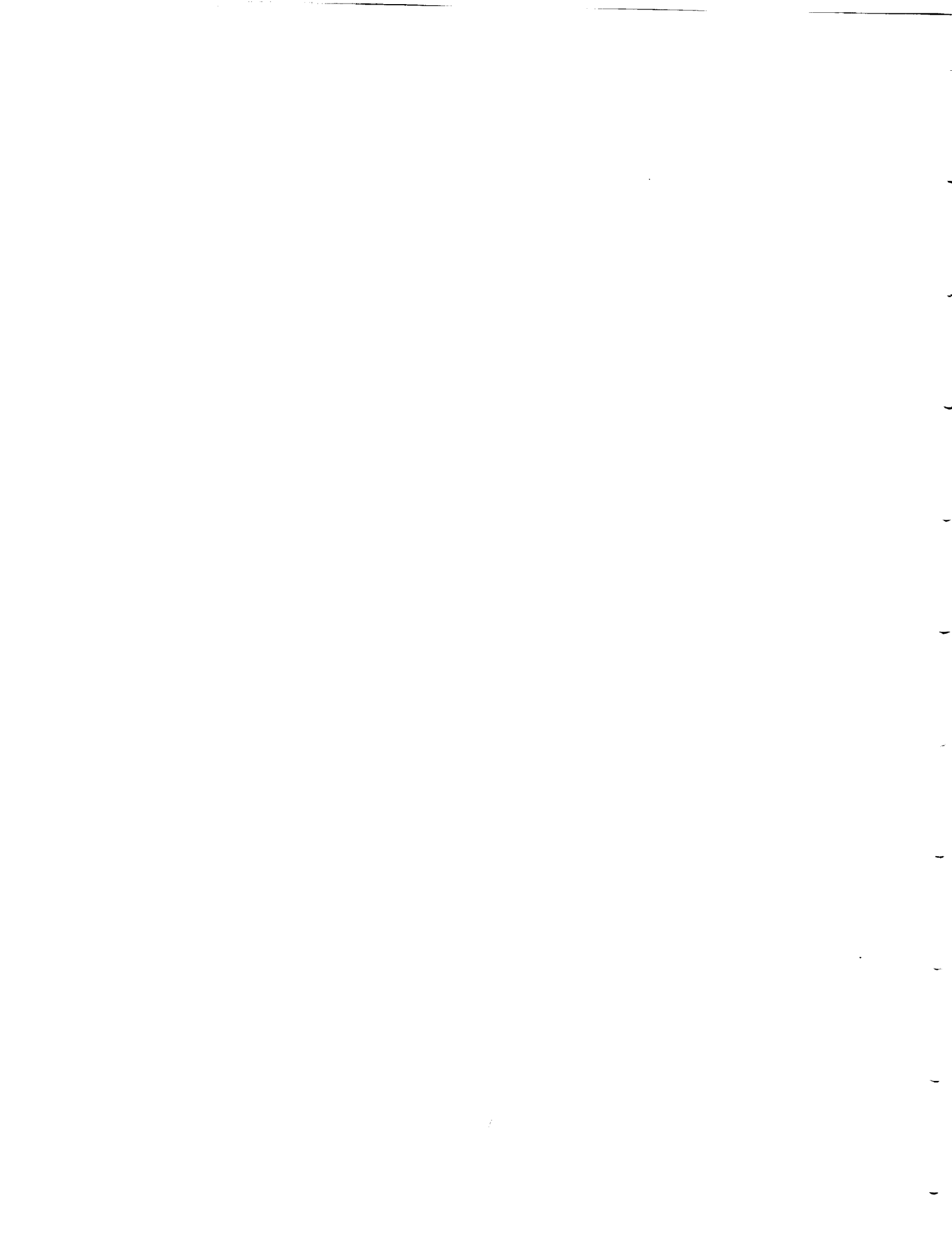

APPENDIX H: SURVEY AND RESPONSES REGARDING MUNICIPAL  
NOISE REGULATIONS

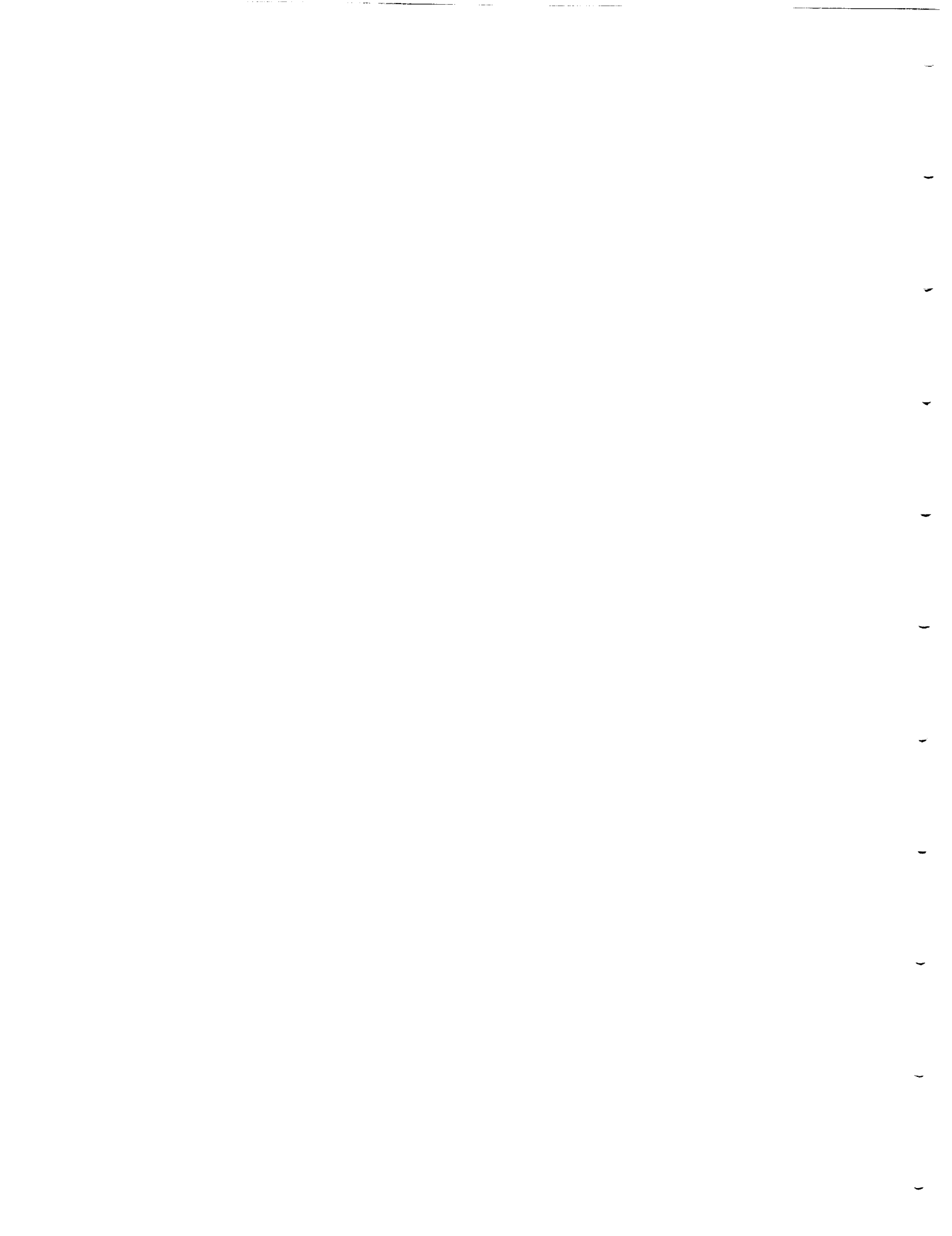

November 1, 1990

Dear Mayor:

Environmental issues are becoming increasingly important at all levels of government. I have compiled a listing of cities that have enacted environmental legislation in several areas, including noise ordinances and the methods for enforcement (i.e., comprehensive plan, zoning, building code, subdivision review, site design, etc.) as a result of several nationwide annual surveys.

Your city has always cooperated by responding, and, I have reported that there are nearly 1,900 such ordinances among cities having a population of 10,000 or more. The results were published in Sound and Vibration and with a text, Municipal Noise Legislation (Fairmont Press and Van Nostrand-Reinhold Press), in 1980.

Due to the interest and positive response, I would like to expand this survey to include several additional potential categories of environmental impact that cities are trying to address including electro-magnetic field (EMF), radon, odor, light pollution and asbestos.

I would appreciate it if the brief questionnaire on the reverse side of this letter could be complete and returned by **January 15, 1991**. As a Professor of City Planning and Special Assistant in the Office of the President at Georgia Tech, I will be very pleased to provide you with a **personal copy** of these findings as soon as the municipal environmental survey is completed.

Thank you for your assistance in this request and for the previous help in my earliest surveys.

Sincerely,

Clifford R. Bragdon, Ph.D., AICP  
Special Assistant, Office of the President  
Professor of City Planning

CRB/vmm

# MUNICIPAL ENVIRONMENTAL SURVEY

(Please list your city and state in the box above.)

1. Has your municipality enacted any ordinance or legislation regarding the following environmental subject areas? If yes, do they contain specific criteria? Please describe.

Environmental Category	Current Regulation		Quantitative Standards, Criteria or Emission Limits		If Yes, Describe the Standards, Criteria or Emission Limits
	Yes	No	Yes	No	
Noise					
Vibration					
Light					
Odor					
Electro-magnetic Field/Radiation					
Radon					
Asbestos					

Comment: \_\_\_\_\_  
 \_\_\_\_\_

2. If no, do you intend to develop any environmental regulations in any of these subject areas within the next six months? If so, which environmental category or categories?

Comment: \_\_\_\_\_  
 \_\_\_\_\_

3. Please check  if your environmental regulations have applicability to the municipal:

- |  |   |
|--|---|
| <input type="checkbox"/> Master Comprehensive Land Use Plan<br><input type="checkbox"/> Zoning Ordinance<br><input type="checkbox"/> Building Code<br><input type="checkbox"/> Subdivision Regulation<br><input type="checkbox"/> Site Design Review<br><input type="checkbox"/> Environmental Impact Assessment | <input type="checkbox"/> Environmental Audit<br><input type="checkbox"/> Capital Improvement Program/Budget<br><input type="checkbox"/> Real Estate Disclosure<br><input type="checkbox"/> Real Property Transfer (Mortgage/Title)<br><input type="checkbox"/> Impact Fee<br><input type="checkbox"/> Other _____ |
|--|---|

Copies of any regulations enacted/proposed in these subject areas, or at least their citation/reference, as a minimum, would be extremely useful. *Thank you.*

Please return to: Clifford R. Bragdon, PhD, AICP      Phone: (404) 894-6914  
 Office of the President      Fax: (404) 853-9163  
 Georgia Institute of Technology  
 Atlanta, GA 30332-0325

PLEASE RETURN BY JANUARY 15, 1991

# MUNICIPAL NOISE CONTROL ORDINANCES AND PROVISIONS. TOTAL RESPONSE BY NUMBER [5.2 & 5.4].

JURISDICTION	TOTAL	NOISE CONTROL ORDINANCES												ORDINANCE PROVISIONS											
		NUISANCE		ZONING		VEHICLES		RECREATION VEHICLES		RAILROAD		AIRCRAFT		CONSTRUCTION		BUILDING CODE		ANIMALS		ENTERTAINMENT					
		NOISE CRITERIA		NOISE CRITERIA		NOISE CRITERIA		NOISE CRITERIA		NOISE CRITERIA		NOISE CRITERIA		NOISE CRITERIA		NOISE CRITERIA		NOISE CRITERIA		NOISE CRITERIA					
		YES	NO	YES	NO	YES	NO	YES	NO	YES	NO	YES	NO	YES	NO	YES	NO	YES	NO	YES	NO	YES	NO		
ALABAMA	15	6	6	5	1	5	3	3	3	4	1	6	0	3	1	3	0	3	0	3	2	2	4		
ALASKA	3	3	0	0	1	0	1	0	0	0	0	0	0	0	0	0	0	0	0	0	0	0	0		
ARIZONA	9	6	3	3	2	5	4	2	3	3	5	1	1	2	0	3	1	1	0	1	0	1	4		
ARKANSAS	7	3	4	1	6	0	0	0	0	0	0	0	0	0	0	1	0	0	0	0	0	0	0		
ARIZONA	137	77	33	68	8	4	18	34	2	8	0	32	2	27	13	17	4	16	12	25	20	3	3		
COLORADO	24	15	15	3	17	6	8	5	3	5	4	2	7	5	2	5	2	6	3	6	3	3	3		
CONNECTICUT	28	12	9	14	0	14	0	8	0	2	0	5	1	6	1	4	0	2	2	2	0	0	0		
DELAWARE	3	2	1	3	0	2	0	0	0	0	0	0	0	0	0	0	0	0	0	0	0	0	0		
District of COLUMBIA	1	1	0	1	0	1	0	1	0	1	0	0	0	0	0	0	0	0	0	0	0	0	0		
FLORIDA	146	87	32	53	2	44	4	30	2	26	0	31	0	32	5	31	2	27	6	30	10	9	9		
GEORGIA	36	11	25	14	5	3	12	6	3	3	2	3	0	6	6	4	0	2	9	5	6	1	1		
HAWAII	1	0	1	1	1	0	0	0	0	0	0	0	0	0	0	0	0	0	0	0	0	0	0		
IDAHO	5	2	2	0	2	3	1	1	1	1	1	0	0	1	2	0	0	0	0	2	0	0	0		
ILLINOIS	365	365	0	365	0	365	0	365	0	0	0	0	0	365	0	0	0	0	0	0	0	0	0		
INDIANA	23	10	7	12	0	12	2	8	1	0	0	4	0	0	7	0	0	6	4	1	5	2	2		
IOWA	17	3	9	6	2	5	6	2	2	0	0	0	0	2	2	0	0	0	0	0	0	0	0		
KANSAS	6	2	2	3	0	2	1	3	0	0	0	0	0	3	0	0	0	0	0	0	0	0	0		
KENTUCKY	10	4	2	3	1	3	3	4	2	3	0	3	0	4	1	1	0	1	1	2	1	4	4		
LOUISIANA	12	7	3	5	1	7	1	3	1	4	0	3	0	4	3	4	1	4	1	1	4	5	1		

**MUNICIPAL NOISE CONTROL ORDINANCES AND PROVISIONS.  
TOTAL RESPONSE BY NUMBER [5.2 & 5.4].**

JURISDICTION	NOISE CONTROL ORDINANCES										ORDINANCES AND PROVISIONS									
	TOTAL					NOISE					ORDINANCE					PROVISIONS				
	NUISANCE		ZONING		VEHICLES		RECREATION VEHICLES		RAILROAD		AIRCRAFT		CONSTRUCTION		BUILDING CODE		ANIMALS		ENTERTAINMENT	
	NOISE CRITERIA	NOISE CRITERIA	NOISE CRITERIA	NOISE CRITERIA	NOISE CRITERIA	NOISE CRITERIA	NOISE CRITERIA	NOISE CRITERIA	NOISE CRITERIA	NOISE CRITERIA	NOISE CRITERIA	NOISE CRITERIA	NOISE CRITERIA	NOISE CRITERIA	NOISE CRITERIA	NOISE CRITERIA	NOISE CRITERIA	NOISE CRITERIA	NOISE CRITERIA	NOISE CRITERIA
1990	YES	NO	YES	NO	YES	NO	YES	NO	YES	NO	YES	NO	YES	NO	YES	NO	YES	NO	YES	NO
MAINE	5	2	0	0	0	0	0	0	0	0	0	0	0	0	0	0	0	0	0	0
MARYLAND	8	4	2	3	0	0	2	1	0	0	0	0	0	0	0	0	0	0	0	0
MASSACHUSETTS	25	12	6	8	2	7	3	3	4	0	7	1	3	2	6	1	1	6	1	4
MICHIGAN	48	18	20	17	4	20	1	12	0	5	1	6	1	7	3	10	1	4	5	3
MINNESOTA	24	9	7	13	1	6	4	10	3	6	3	2	3	5	2	5	0	6	3	3
MISSOURI	52	50	8	50	1	9	1	1	1	6	1	5	1	8	3	4	1	5	5	4
MISSISSIPPI	4	3	1	0	0	0	0	0	0	0	0	0	0	0	0	0	0	0	0	0
MONTANA	8	2	5	5	0	4	1	5	0	3	0	4	0	3	0	2	0	2	0	0
NEBRASKA	10	3	4	3	0	3	3	0	3	0	0	3	0	0	0	3	3	0	0	3
NEW HAMPSHIRE	5	1	3	0	0	2	0	1	0	0	1	0	1	0	0	0	1	0	1	0
NEW JERSEY	80	26	53	36	4	11	5	6	1	4	0	4	1	3	8	2	3	2	2	8
NEW MEXICO	5	1	3	1	1	3	1	1	1	0	0	2	1	2	0	0	2	1	1	1
NEW YORK	57	22	29	17	1	12	21	1	6	0	3	6	1	5	9	4	1	4	8	6
NEVADA	3	1	1	2	0	0	1	0	0	0	2	0	0	2	0	0	0	0	1	0
NORTH CAROLINA	59	4	53	9	1	6	7	3	2	2	1	2	1	2	8	2	1	2	7	4
NORTH DAKOTA	2	1	1	0	0	1	0	0	0	0	0	0	0	0	0	0	0	0	0	0
OHIO	31	15	7	12	4	14	2	7	3	5	2	2	3	3	2	3	2	5	3	3
OKLAHOMA	10	5	3	4	0	4	1	4	0	0	2	1	2	1	4	0	0	2	2	3
OREGON	40	17	15	18	3	15	6	5	2	5	0	1	6	2	2	2	2	3	3	3







**MUNICIPAL NOISE CONTROL ORDINANCES AND PROVISIONS.  
TOTAL RESPONSE BY PERCENTAGE [5.2 & 5.4].**

JURISDICTION	TOTAL 1990	NOISE CONTROL ORDINANCES												PROVISIONS																											
		NUISANCE				ZONING				VEHICLES				RECREATION VEHICLES				RAILROAD				AIRCRAFT				CONSTRUCTION				BUILDING CODE				ANIMALS				ENTERTAINMENT			
		NOISE CRITERIA		NOISE CRITERIA		NOISE CRITERIA		NOISE CRITERIA		NOISE CRITERIA		NOISE CRITERIA		NOISE CRITERIA		NOISE CRITERIA		NOISE CRITERIA		NOISE CRITERIA		NOISE CRITERIA		NOISE CRITERIA		NOISE CRITERIA		NOISE CRITERIA		NOISE CRITERIA		NOISE CRITERIA		NOISE CRITERIA							
		YES	NO	YES	NO	YES	NO	YES	NO	YES	NO	YES	NO	YES	NO	YES	NO	YES	NO	YES	NO	YES	NO	YES	NO	YES	NO	YES	NO	YES	NO	YES	NO	YES	NO						
MAINE	6	40.0	0.0	0.0	0.0	0.0	0.0	0.0	0.0	0.0	0.0	0.0	0.0	0.0	0.0	0.0	0.0	0.0	0.0	0.0	0.0	0.0	0.0	0.0	0.0	0.0	0.0	0.0	0.0	0.0	0.0	0.0	0.0								
MARYLAND	8	50.0	25.0	37.5	0.0	0.0	0.0	0.0	0.0	0.0	0.0	0.0	0.0	0.0	0.0	0.0	0.0	0.0	0.0	0.0	0.0	0.0	0.0	0.0	0.0	0.0	0.0	0.0	0.0	0.0	0.0	0.0	0.0								
MASSACHUSETTS	25	48.0	24.0	32.0	8.0	28.0	12.0	12.0	12.0	12.0	12.0	12.0	12.0	12.0	12.0	12.0	12.0	12.0	12.0	12.0	12.0	12.0	12.0	12.0	12.0	12.0	12.0	12.0	12.0	12.0	12.0	12.0	12.0								
MICHIGAN	48	37.5	41.7	35.4	8.3	41.7	2.1	2.1	2.1	2.1	2.1	2.1	2.1	2.1	2.1	2.1	2.1	2.1	2.1	2.1	2.1	2.1	2.1	2.1	2.1	2.1	2.1	2.1	2.1	2.1	2.1	2.1	2.1								
MINNESOTA	24	37.5	29.2	54.2	4.2	25.0	16.7	16.7	16.7	16.7	16.7	16.7	16.7	16.7	16.7	16.7	16.7	16.7	16.7	16.7	16.7	16.7	16.7	16.7	16.7	16.7	16.7	16.7	16.7	16.7	16.7	16.7	16.7								
MISSOURI	52	96.2	15.4	96.2	1.92	17.3	1.92	1.92	1.92	1.92	1.92	1.92	1.92	1.92	1.92	1.92	1.92	1.92	1.92	1.92	1.92	1.92	1.92	1.92	1.92	1.92	1.92	1.92	1.92	1.92	1.92	1.92	1.92								
MISSISSIPPI	4	75.0	25.0	0.0	0.0	0.0	0.0	0.0	0.0	0.0	0.0	0.0	0.0	0.0	0.0	0.0	0.0	0.0	0.0	0.0	0.0	0.0	0.0	0.0	0.0	0.0	0.0	0.0	0.0	0.0	0.0	0.0	0.0								
MONTANA	8	25.0	62.5	62.5	0.0	50.0	12.5	12.5	12.5	12.5	12.5	12.5	12.5	12.5	12.5	12.5	12.5	12.5	12.5	12.5	12.5	12.5	12.5	12.5	12.5	12.5	12.5	12.5	12.5	12.5	12.5	12.5	12.5								
NEBRASKA	10	30.0	40.0	30.0	0.0	30.0	30.0	30.0	30.0	30.0	30.0	30.0	30.0	30.0	30.0	30.0	30.0	30.0	30.0	30.0	30.0	30.0	30.0	30.0	30.0	30.0	30.0	30.0	30.0	30.0	30.0	30.0	30.0								
NEW HAMPSHIRE	5	20.0	60.0	0.0	0.0	40.0	0.0	0.0	0.0	0.0	0.0	0.0	0.0	0.0	0.0	0.0	0.0	0.0	0.0	0.0	0.0	0.0	0.0	0.0	0.0	0.0	0.0	0.0	0.0	0.0	0.0	0.0	0.0								
NEW JERSEY	80	32.5	66.3	45.0	5.0	13.8	6.3	7.5	1.3	7.5	1.3	7.5	1.3	7.5	1.3	7.5	1.3	7.5	1.3	7.5	1.3	7.5	1.3	7.5	1.3	7.5	1.3	7.5	1.3	7.5	1.3	7.5	1.3								
NEW MEXICO	5	20.0	60.0	20.0	20.0	60.0	20.0	20.0	20.0	20.0	20.0	20.0	20.0	20.0	20.0	20.0	20.0	20.0	20.0	20.0	20.0	20.0	20.0	20.0	20.0	20.0	20.0	20.0	20.0	20.0	20.0	20.0	20.0								
NEW YORK	57	38.6	50.9	29.8	1.8	21.1	36.8	1.8	10.5	0.0	5.3	8.8	1.8	10.5	0.0	5.3	8.8	1.8	10.5	0.0	5.3	8.8	1.8	10.5	0.0	5.3	8.8	1.8	10.5	0.0	5.3	8.8	1.8								
NEVADA	3	33.3	33.3	66.7	0.0	0.0	33.3	0.0	0.0	0.0	0.0	0.0	0.0	0.0	0.0	0.0	0.0	0.0	0.0	0.0	0.0	0.0	0.0	0.0	0.0	0.0	0.0	0.0	0.0	0.0	0.0	0.0	0.0								
NORTH CAROLINA	59	6.8	88.8	18.3	1.7	10.2	11.9	5.1	3.4	3.4	1.7	3.4	1.7	3.4	1.7	3.4	1.7	3.4	1.7	3.4	1.7	3.4	1.7	3.4	1.7	3.4	1.7	3.4	1.7	3.4	1.7	3.4	1.7								
NORTH DAKOTA	2	50.0	50.0	0.0	0.0	50.0	0.0	0.0	0.0	0.0	0.0	0.0	0.0	0.0	0.0	0.0	0.0	0.0	0.0	0.0	0.0	0.0	0.0	0.0	0.0	0.0	0.0	0.0	0.0	0.0	0.0	0.0	0.0								
OHIO	31	48.4	22.6	38.7	12.9	45.2	6.5	22.6	9.7	16.1	6.5	9.7	16.1	6.5	9.7	16.1	6.5	9.7	16.1	6.5	9.7	16.1	6.5	9.7	16.1	6.5	9.7	16.1	6.5	9.7	16.1	6.5	9.7								
OKLAHOMA	10	50.0	30.0	40.0	0.0	40.0	10.0	40.0	0.0	0.0	0.0	0.0	0.0	0.0	0.0	0.0	0.0	0.0	0.0	0.0	0.0	0.0	0.0	0.0	0.0	0.0	0.0	0.0	0.0	0.0	0.0	0.0	0.0								
OREGON	40	42.5	37.5	45.0	7.5	37.5	15.0	12.5	5.0	12.5	0.0	2.5	0.0	12.5	0.0	2.5	0.0	12.5	0.0	2.5	0.0	12.5	0.0	2.5	0.0	12.5	0.0	2.5	0.0	12.5	0.0	2.5	0.0								



APPENDIX I: AIRSPACE DEFINITIONS

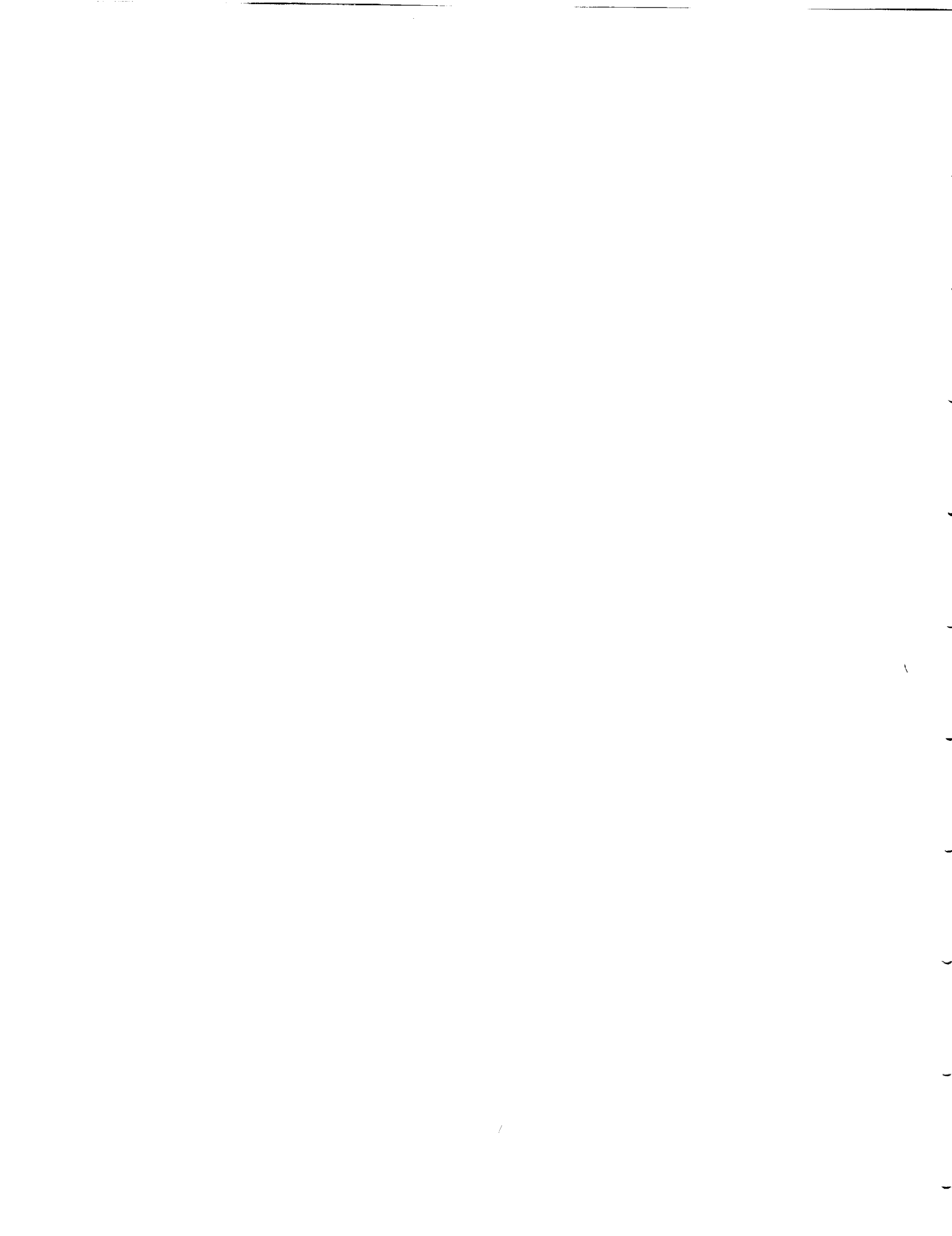

**AIRPORT**-- An area of land or water that is used or intended to be used for the landing and takeoff of aircraft and includes its buildings and facilities, if any. An uncontrolled airport has no control tower. A controlled airport has a control tower.

**AIRPORT RADAR SERVICE AREA (ARSA)**-- Regulatory airspace surrounding designated airports wherein ATC provides radar vectoring and sequencing on a full-time basis for all IFR and VFR aircraft. Their service provided in as ARSA is called ARSA service which includes- IFR/VFR- standard IFR separation; IFR/VFR- traffic advisories and conflict resolution; and VFR/VFR- traffic advisories and, as appropriate, safety alerts.

**AIR ROUTE TRAFFIC CONTROL CENTER (ARTCC)**-- A facility established to provide air traffic control service to aircraft operating on IFR flight plans within controlled airspace and principally during the in route phase of flight. When equipment capabilities and controller workload permit, certain advisory/assistance service may be provided to VFR aircraft.

**AIR TRAFFIC CONTROL**-- A service operated by appropriate authority to promote the safe and orderly and expeditious flow of air traffic.

**APPROACH CONTROL SERVICE**-- Air traffic control service provided by an approach control facility for arriving and departing VFR/IFR aircraft and, on occasion, in route aircraft. At some airports not served by an approach control facility, the ARTCC provides limited approach control service.

**CONTINENTAL CONTROL AREA**-- The airspace of the 48 contiguous States, the District of Columbia and Alaska, excluding the Alaska peninsula west of Long. 160 00'00"W, at and above 14,500 feet MSL, but does not include: the airspace less than 1,500 feet above the surface of the earth; or prohibited and restricted areas, other than the restricted areas listed in FAA Part 71.

**CONTROL AREA**-- Airspace designated as Colored Federal airways, VOR Federal airways, control areas associated with jet routes outside the continental control area, additional control areas, control area extensions, and area low routes. Control areas do not include the continental control area, but unless otherwise designated, they do include the airspace between a segment of a main VOR Federal airway and its associated alternate segments with the vertical extent of the area corresponding to the vertical extent of the related segment of the main airway. The vertical extent of the various categories of airspace contained in control areas is defined in FAR Part 71.

**CONTROLLED AIRSPACE**-- Airspace designated as a control zone, airport radar service area, terminal control area, transition area, continental control area and positive control area within which some or all aircraft may be subject to air traffic control.

**CONTROL ZONE**-- Controlled airspace which extends upward from the surface of the earth and terminates at the base of the continental control area. Control zones that do

not underlie the continental control area have no upper limit. A control zone may include one or more airports and is normally a circular area with a radius of 5 statute miles and any extensions necessary to include instrument approach and departure paths.

**FLIGHT TRACK--** The flight path of an aircraft as projected across the ground.

**IFR AIRCRAFT/ IFR FLIGHT--** An aircraft conducting flight in accordance with instrument flight rules.

**NOISE SENSITIVE AREA--** An area in which aircraft noise may interfere with the normal activities associated with use of the land. Noise sensitive areas may include residential neighborhoods, educational, health, and religious structures and sites and outdoor recreational, cultural, and historic sites. Whether noise interferes with a particular use depends upon the level of noise exposure received and the type of activities involved. A site which is unacceptable for outside use may be acceptable for use inside a structure, if adequate noise attenuation features are built into that structure.

**POSITIVE CONTROL AREA (PCA)--** Airspace designated in FAR, Part 71 within which there is positive control of aircraft. Flight in PCA is normally conducted under instrument flight rules. PCA is designated throughout most of the conterminous United States and its vertical extent is from 18,000 feet MSL to an including flight level 600. In Alaska PCA does not include the airspace less than 1,500 feet above the surface of the earth nor the airspace over the Alaska Peninsula west of longitude 160 degrees West. Rules for operating in PCA are found in FAR's 91.97 and 91.24.

**SEPARATION--** In air traffic control, the spacing of aircraft to achieve their safe and orderly movement in flight and while landing and taking off.

**SEPARATION MINIMA--** The minimum longitudinal, lateral or vertical distances by which aircraft are spaced through the application of air traffic control procedures.

**TERMINAL CONTROL AREA (TCA)--** Controlled airspace extending upward from the surface or higher to specified altitudes, within which all aircraft are subject to operating rules and pilot and equipment requirements specified in FAR Part 91.

**TRANSITION AREA--** Controlled airspace extending upward from 700 feet or more above the surface of the earth when designated in conjunction with an airport for which an approved instrument approach procedure has been prescribed; or from 1,200 or more above the surface of the earth when designated in conjunction with airway route structures or segments. Unless otherwise specified, transition areas terminate at the base of the overlying controlled airspace. Transition areas are designed to contain IFR operations in controlled airspace during portions of the terminal operations and while transiting between the terminal and enroute environment.



VFR AIRCRAFT/ VFR FLIGHT-- An aircraft conducting flight in accordance with visual flight rules.

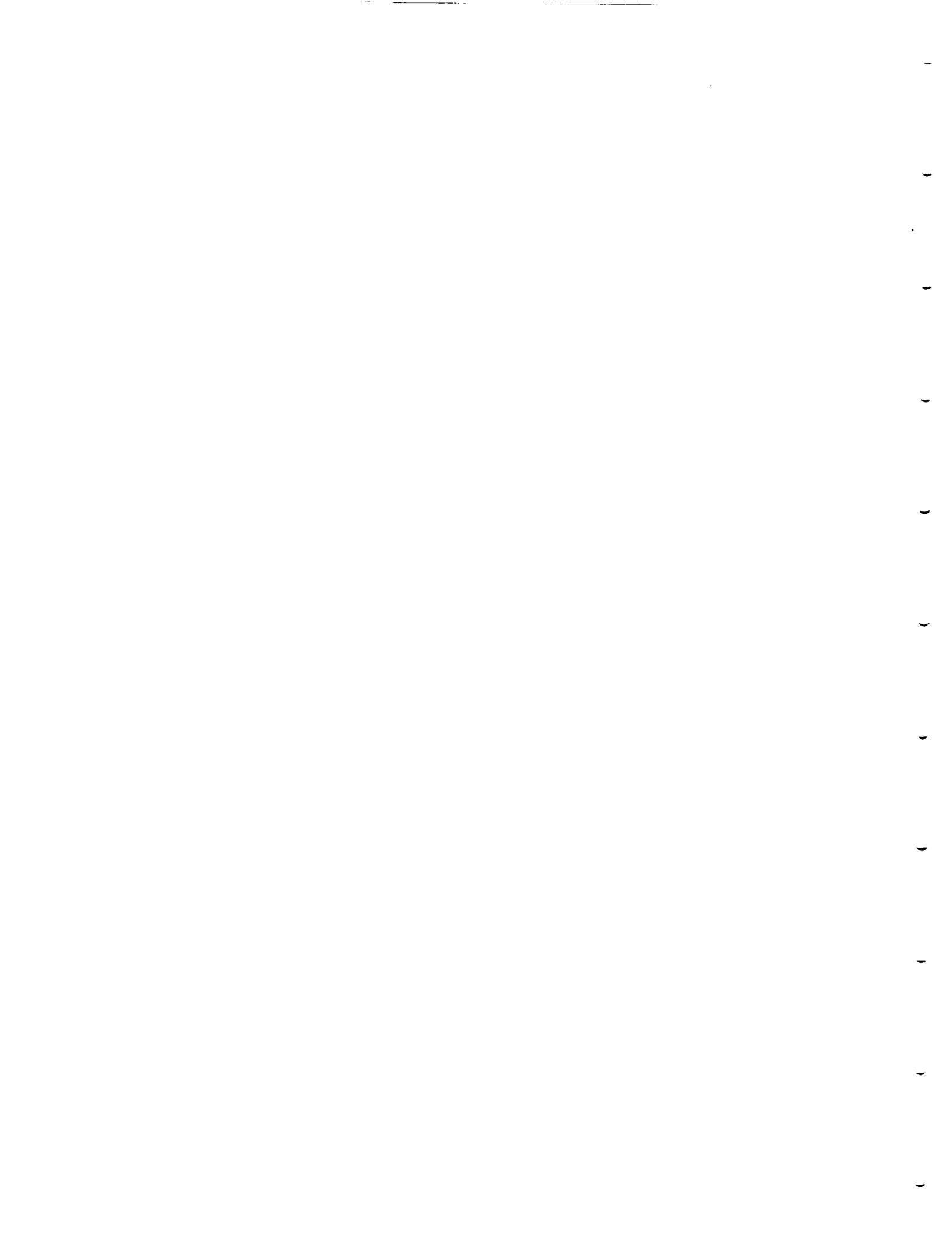

**APPENDIX J: FIELD HEADINGS FOR OPERATIONAL CONTROL MEASURES**

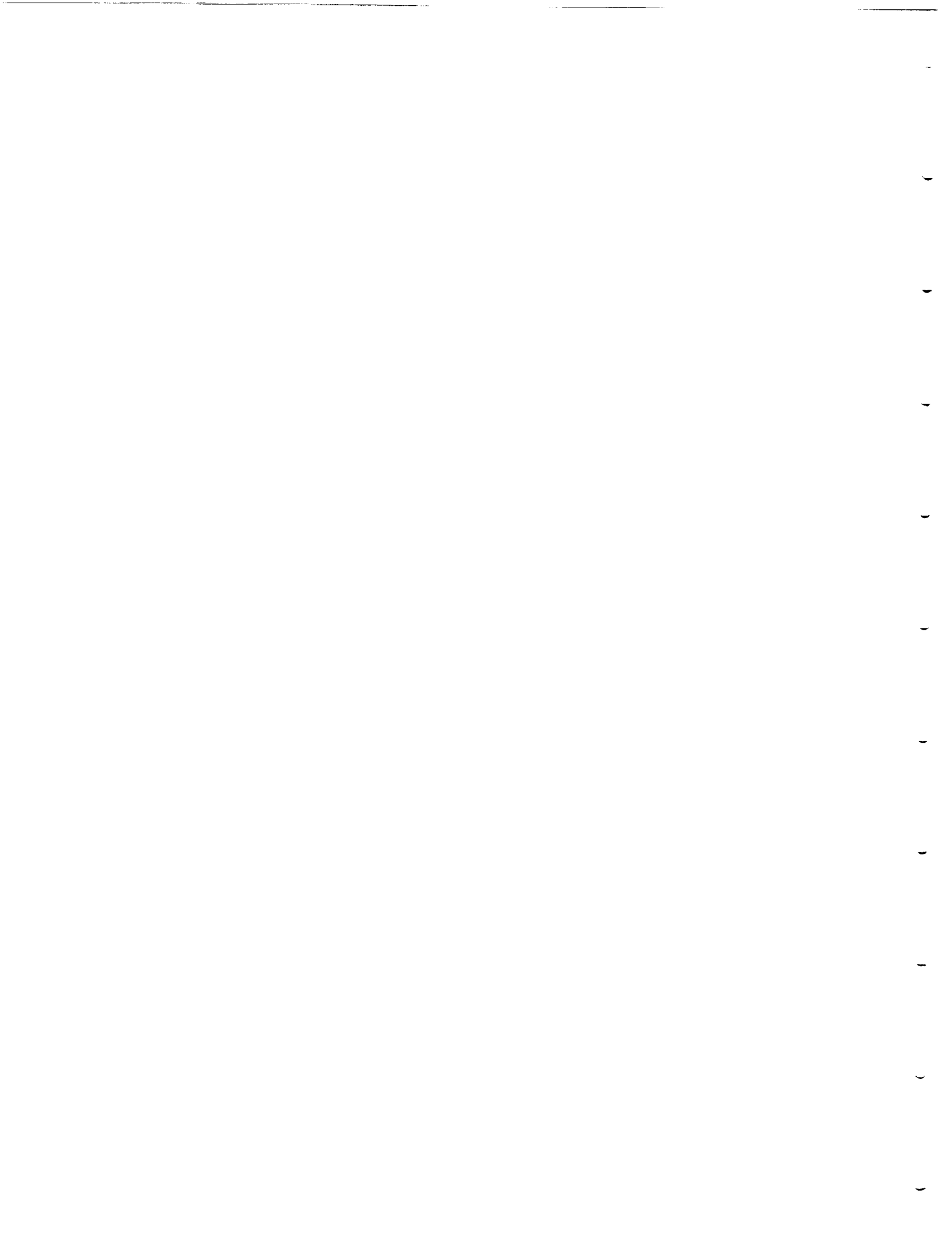

## FIELD NAME

Name- name of airport  
Code- airport code  
City- location of airport  
State- location of airport  
Primary- name of primary runway  
Secondary- name of secondary runway  
Ann Ops- number of annual operations  
Pass Enpl- number of passengers  
Ancluc- air noise compatibility program  
Nem- noise exposure map  
Ncp- noise compatibility program  
150 Prog- part 150 progress  
Contact tel- contact person/telephone #  
Noise perm- permanent noise monitoring system  
Noise temp- temporary noise monitoring system  
Runup- aircraft maintenance  
Sel- single event level noise measurement  
Ldn- day night level noise measurement  
Actraining- "touch and goes"  
Even rest- restrictions between 1900-2200 hrs  
Night rest- restrictions between 2200-0700 hrs  
Curfew- curfew on certain operations/planes  
Ban- a ban of certain operations/planes  
Pref runway- preferred runway  
Prevail wind- as a consideration of takeoff  
VFR- visual flight rules  
Land proceed- landing procedures

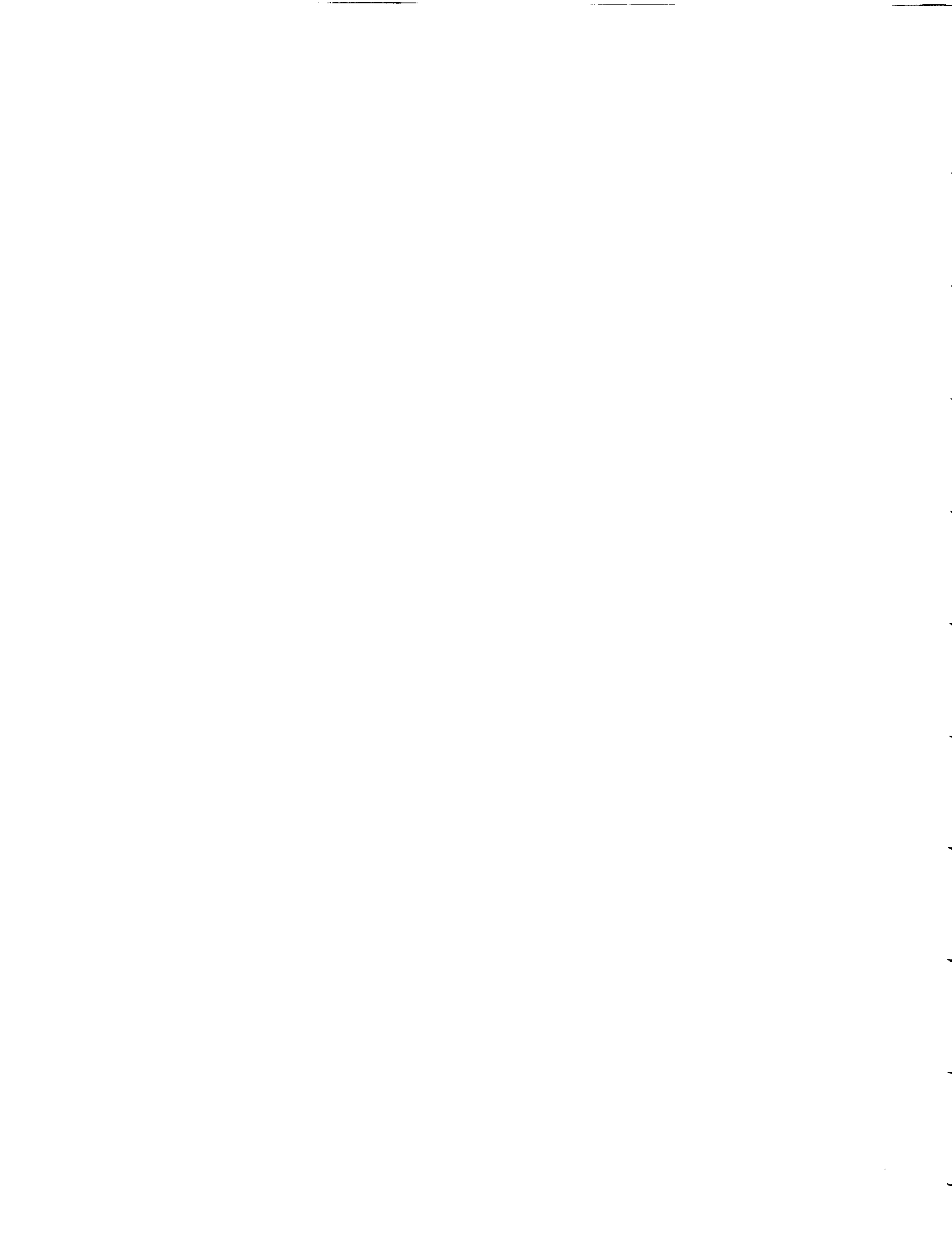

APPENDIX K: FAA PART 36: NOISE STANDARDS

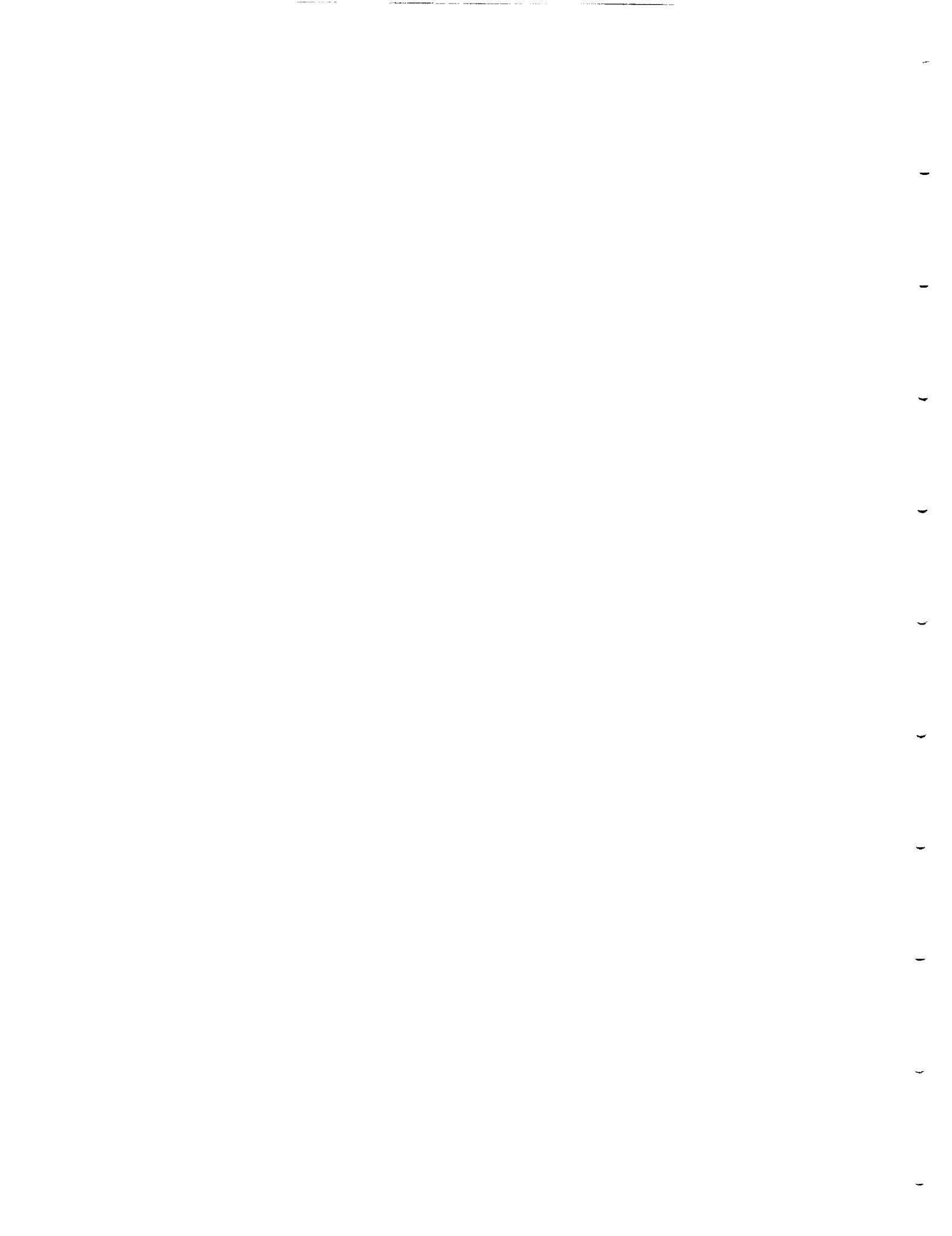



## Certification

Certification covers subsonic, propeller-driven small airplanes, and concord. Details include:

- (i) Type certificates, and changes to those certificates, and standard airworthiness certificates, for subsonic transport category large airplanes, and for subsonic turbojet powered airplanes regardless of category.
- (ii) Type certificates and changes to those certificates, and standard airworthiness certificates and restricted category airworthiness certificates, for propeller-driven small airplanes, except airplanes that are designed for "agricultural aircraft operations".
- (iii) A type of certificate and changes to that certificate, and standard airworthiness certificates; for Concorde airplanes.

Each person who applies for the original issue of a standard airworthiness certificate for a transport category large airplane or a turbojet powered airplane regardless of the date of application, must show compliance with the following provisions:

1. The provisions of this Part in effect on December 1, 1989, for the subsonic airplanes that have not had any flight time before
  - a. December, 1973, for airplanes with maximum weights greater than 75,000 pounds, except for airplanes that powered by Pratt and Whitney Turbo Wasp JT3D series engines;
  - b. December 31, 1974 for airplanes with maximum weights greater than 75,000 pound ant that are powered by Pratt and Whitney Turbo Wasp JT3D series engines; and
  - c: December 31, 1974 for airplanes with maximum weights of 75,000 pounds and less.
2. The provision of the Part in effect on October 13, 1977 including the Stage 2 noise limits, for Concorde airplanes that have not had flight time before January 1, 1980.

## Definitions

Several acoustical terms specifically discussed in this regulation are given below. For a complete set of acoustical terms refer to Section 3 Sound Metrics and Descriptors.

<u>Symbol</u>	<u>Unit</u>	<u>Meaning</u>
PNLM	PNdB	PNdB Maximum Perceived Noise Level. The maximum value of PNL(K) that occurs during the aircraft flyover.
C(k)	dB	Tone Correction. The factor to be added to PLN(K) to account for the presence of spectral irregularities such as tones at the K-th increment of time.
D	dB	Duration Correction. The factor to be added to PLNM to account for the duration of noise.
EPNL	EPNdB	Effective Perceived Noise Level. The value of PNL adjusted for both the presence or discrete frequencies and the time history.

### Noise Measuring Points

There are three measurement points used for measuring noise and they include takeoff, approach and sideline locations (Figure 6.2). The details of each follow:

- a. For takeoff, at a point 21,325 feet from the start of the takeoff roll on the extended centerline of the runway;
- b. For approach, at a point 6,562 feet from the threshold on the extended centerline of the runway; and
- c. For the sideline, at the point, on a line parallel to and 1,476 feet from the extended centerline of the runway, where the noise level after liftoff is greatest, except that, for an airplane powered by more than three turbojet engines this distance must be 0.35 nautical miles for the purpose of showing compliance with State 1 or Stage 2 noise limits (as applicable).

### Noise Levels

Limits: Except as provided in b. and c. above, it must be shown by flight test that the noise levels of the airplane at the measuring points do not exceed:

- a. Stage 1 noise limits for acoustical changes for airplanes regardless of the number of engines and those noise levels greater than that of Stage 2 noise limits mentioned next.
- b. Stage 2 noise limits for airplanes regardless of the number of engines are as follows:

(i) For takeoff:

For airplanes with more than 3 engines: 106 EPNdB for maximum weights of 85,000 pounds or more, reduced by 4 EPNdB per halving of the 85,000 pounds maximum weight down to 89 EPNdB for maximum weights of 44,673 pounds or less;

For airplanes with 3 engines,: 104 EPNdB for maximum weights of 85,000 pounds or more, reduced by 4 EPNdB per halving of the 85,000 pounds maximum weight down to 89 EPNdB for maximum weights of 63,177 pounds or less; and

For airplanes with fewer than 3 engines: 101 EPNdB for maximum weights of 85,000 pounds or more, reduced by 4 EPNdB per halving of the 85,000 pounds maximum weight down to 89 DPNdb for maximum weights of 106,250 pounds or less.

(ii) For Sideline, regardless of the number of engines: 103 EPNdB for maximum weights of 882,000 pounds or more, reduced by 2,56 EPNdb per halving of the 882,000 pounds maximum weight down to 94 EPNdB for maximum weights of 77,200 pounds or less.

(iii) For approach, regardless of the number of engines: 105 EPNdB for maximum weights of 617,300 pounds or more, reduced by 2.33 EPNdB per halving of the 617,300 pounds weight down to 98 EPNdB for maximum weights of 77,200 pounds or less.

**Test Conditions: Takeoff**

Takeoff power or thrust must be used from the start of takeoff roll to at least the following altitude above the runway:

a1. For Stage 1 or Stage 2 airplanes:

(i) For airplanes with more than three turbojet engines - 700 feet

(ii) For all other airplanes - 1000 feet.

a2. For Stage 3 airplanes:

(i) For airplanes with more than three turbojet engines - 669 feet

(ii) For airplanes with three turbojet engines - 853 feet

- (iii) For airplanes with fewer than three turbojet engines - 984 feet
- (iv) For airplanes not powered by turbojet engines - 1000 feet
- b. Upon reaching the altitude specified in (a), the power or thrust may not be reduced below that needed to maintain level flight with one engine inoperative, or to maintain a four percent climb gradient, whichever power or thrust is greater.
- c. Except as provided in (e), a speed of at least  $V_2 + 10$  knots must be attained as soon as practicable after liftoff, and must be maintained throughout the takeoff noise test.
- d. A constant takeoff configuration, selected by the applicant, must be maintained throughout the takeoff noise test, except that the land gear may be retracted.
- e. For applications made for subsonic airplanes after September 17, 1971, and for Concorde airplanes, the following apply:
  - (i) For subsonic airplanes the test day speeds and the acoustic day reference speed must be the minimum approved value of  $V_2 + 10$  knots, or all engines operating speed at 35 feet (for turbine engine powered airplanes) or 50 feet (for reciprocating engine powered airplanes), whichever speed is greater as determined under the regulations constituting the type certification basis of the airplane.
  - (ii) For Concorde airplanes, the test day speeds and the acoustic day reference speed must be the minimum approved of  $V_2 + 25$  knots, or all the engines operating at 35 feet, whichever is greater as determined under the regulations constituting the type certification basis of the airplane, except that the reference speed may not exceed 250 knots.

#### Test Conditions: Approach

- a. The airplane's configuration must be that used in showing compliance with the landing requirements in the airworthiness regulations constituting the type certification basis for the airplane. If more than one configuration is used in showing compliance with the landing requirements in the airworthiness regulations constituting the type certification basis of the airplane, the configuration that is most critical from a noise standpoint must be used.
- b. The approaches must conduct with a steady glide angle of 3 degrees  $\pm$  0.5 degree and must be continued to a normal touchdown with no airframe

configuration change.

- c. Except as provided in (e), a steady approach speed of not less than  $1.30V_s + 10$  knots must be established and maintained over the approach measuring point.
- d. All engines must be operating at approximately the same power of thrust.
- e. For applications made for subsonic airplanes after September 17, 1991 and for Concorde airplanes:
  - (i) For subsonic airplanes a steady approach speed, that is either  $1.30 V_s + 10$  knots or the speed used in establishing the approved land distance under the airworthiness regulations constituting the type certification basis of the airplane, must be established and maintained over the approach measuring point.
  - (ii) For Concorde airplanes, a steady approach speed, that is either the land reference speed + 10 knots or the speed used in establishing the approved land distance under the airworthiness regulations constituting the type certification basis of the airplane, whichever speed is greater, must be established and maintained over the approach measuring point.

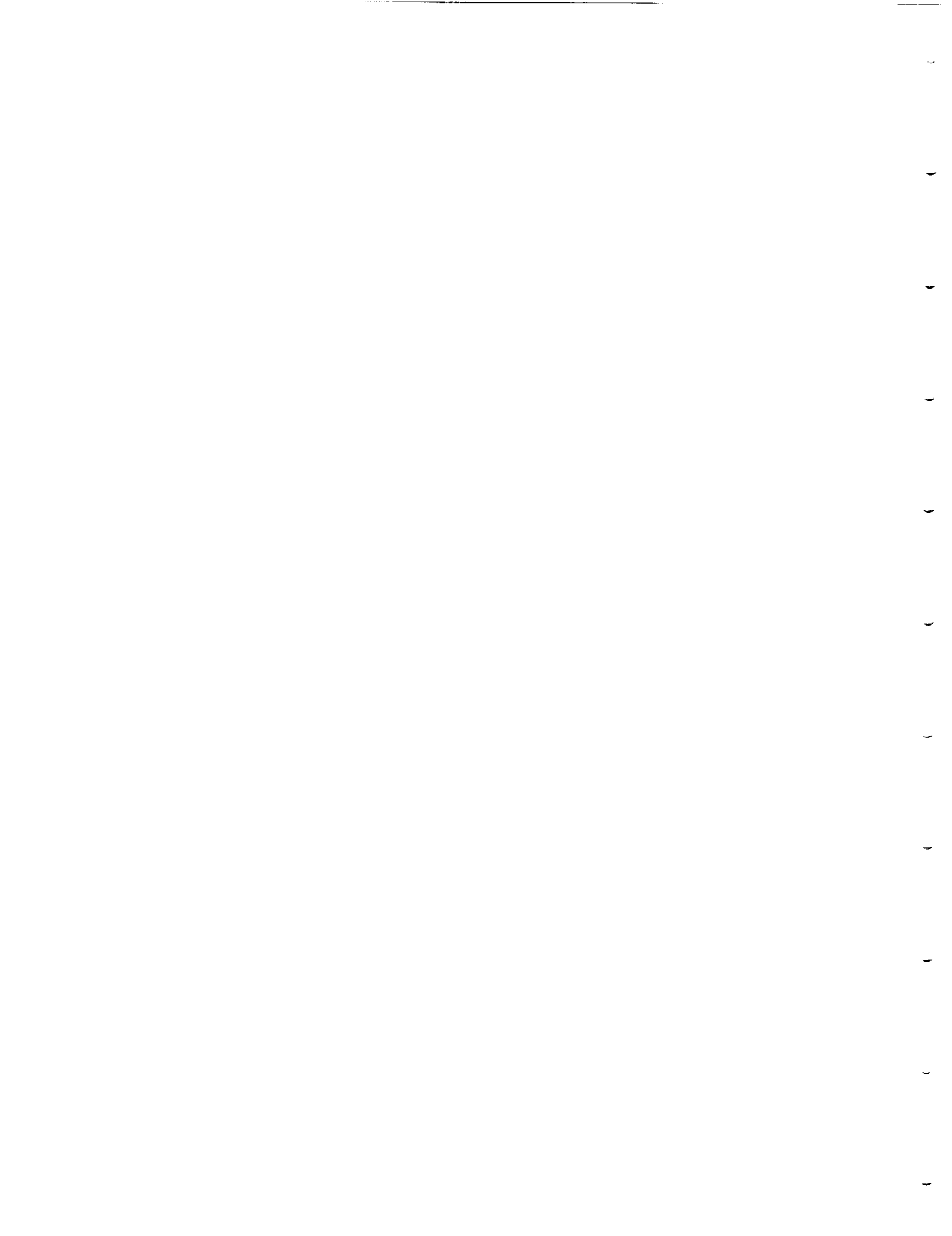

APPENDIX L: FAA PART 150: LAND USE COMPATIBILITY

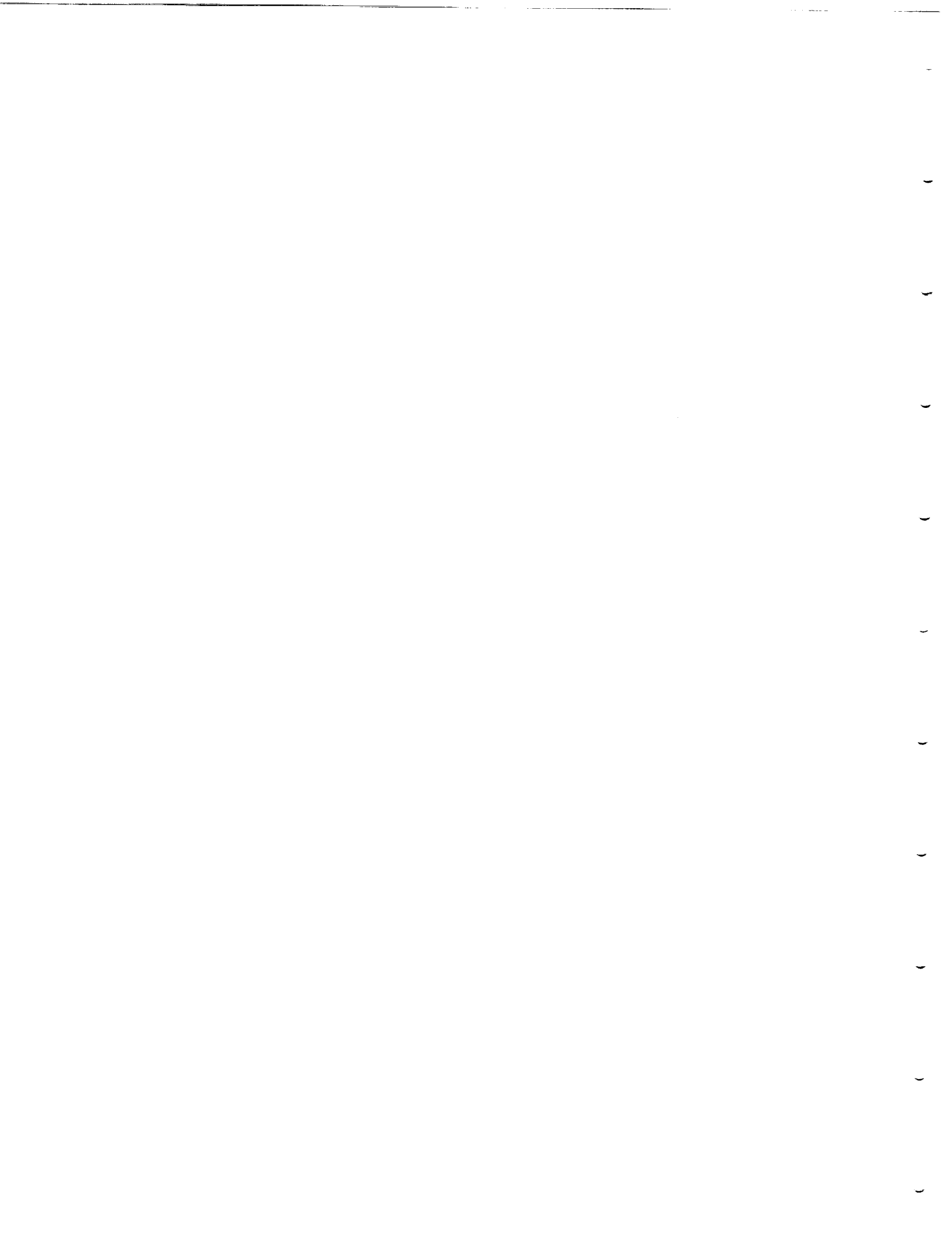



## LAND USE COMPATIBILITY\* WITH YEARLY DAY-NIGHT AVERAGE SOUND LEVELS

<i>Land Use</i>	<i>Yearly Day-Night Average Sound Level (L<sub>dn</sub>) in Decibels</i>					
	<i>Below 65</i>	<i>65-70</i>	<i>70-75</i>	<i>75-80</i>	<i>80-85</i>	<i>Over 85</i>
<i>Residential</i>						
Residential, other than mobile homes and transient lodgings	Y	N(1)	N(1)	N	N	N
Mobile home parks	Y	N	N	N	N	N
Transient lodgings	Y	N(1)	N(1)	N(1)	N	N
<i>Public Use</i>						
Schools	Y	N(1)	N(1)	N	N	N
Hospitals and nursing homes	Y	25	30	N	N	N
Churches, auditoriums, and concert halls	Y	25	30	N	N	N
Governmental services	Y	Y	25	30	N	N
Transportation	Y	Y	Y(2)	Y(3)	Y(4)	Y(4)
Parking	Y	Y	Y(2)	Y(3)	Y(4)	N
<i>Commercial Use</i>						
Offices, business and professional	Y	Y	25	30	N	N
Wholesale and retail-building materials, hardware and farm equipment	Y	Y	Y(2)	Y(3)	Y(4)	N
Retail trade - general	Y	Y	25	30	N	N
Utilities	Y	Y	Y(2)	Y(3)	Y(4)	N
Communications	Y	Y	25	30	N	N
<i>Manufacturing and Production</i>						
Manufacturing, general	Y	Y	Y(2)	Y(3)	Y(4)	N
Photographic and optical	Y	Y	25	30	N	N
Agriculture (except livestock) and forestry	Y	Y(6)	Y(7)	Y(8)	Y(8)	Y(8)
Livestock farming and breeding	Y	Y(6)	Y(7)	N	N	N
Mining and fishing, resource production and extraction	Y	Y	Y	Y	Y	N
<i>Recreational</i>						
Outdoor sports arenas and spectator sports	Y	Y(5)	Y(5)	N	N	N
Outdoor music shells, amphitheaters	Y	N	N	N	N	N
Nature exhibits and zoos	Y	Y	N	N	N	N
Amusements, parks, resorts and camps	Y	Y	Y	N	N	N
Golf courses, riding stables and water recreation	Y	Y	25	30	N	N

Numbers in parentheses refer to notes.

\* The designations contained in this table do not constitute a Federal determination that any use of land covered by the program is acceptable or unacceptable under Federal, State, or local law. The responsibility for determining the acceptable and permissible land uses and the relationship between specific properties and specific noise contours rests with the local authorities. FAA determinations under PART 150 are not intended to substitute federally determined land uses for those determined to be appropriate by local authorities in response to locally determined needs and values in achieving noise compatible land uses.

## NOTES AND KEY

### KEY TO TABLE 1

SLUCM Standard Land Use Coding Manual.

Y(YES) Land Use and related structures compatible without restrictions.

N(NO) Land Use and related structures are not compatible and should be prohibited.

NLR Noise Level Reduction (outdoor to indoor) to be achieved through incorporation of noise attenuation into the design and construction of the structure.

25,30,35 Land used and related structures generally compatible; measures to achieve NLR of 25,30, or 35 dB must be incorporated into design and construction of structure.

### NOTES FOR TABLE 1

- (1) Where the community determines that residential or school uses must be allowed, measures to achieve outdoor to indoor Noise Level Reduction (NLR) of at least 25 dB and 30 dB should be incorporated into building codes and be considered in individual approvals. Normal residential construction can be expected to provide a NLR of 20 dB thus, the reduction requirements are often stated as 5, 10, or 15 dB over standard construction and normally assume mechanical ventilation and closed windows year round. However, the use of NLR criteria will not eliminate outdoor noise problems.
- (2) Measures to achieve NLR of 25 dB must be incorporated into the design and construction of portions of these buildings where the public is received, office areas, noise sensitive areas or where the normal noise level is low.
- (3) Measures to achieve NLR of 30 dB must be incorporated into the design and construction of portions of these buildings where the public is received, office areas, noise sensitive areas or where the normal noise level is low.
- (4) Measures to achieve NLR of 35 dB must be incorporated into the design and construction of portions of these buildings where the public is received, office areas, noise sensitive areas or where the normal noise level is low.
- (5) Land use compatible provided special sound reinforcement systems are installed.
- (6) Residential buildings require an NLR of 25.
- (7) Residential buildings require an NLR of 30.
- (8) Residential buildings not permitted.

APPENDIX M: FAA PART 77: OBJECTS AFFECTING NAVIGABLE AIRSPACE

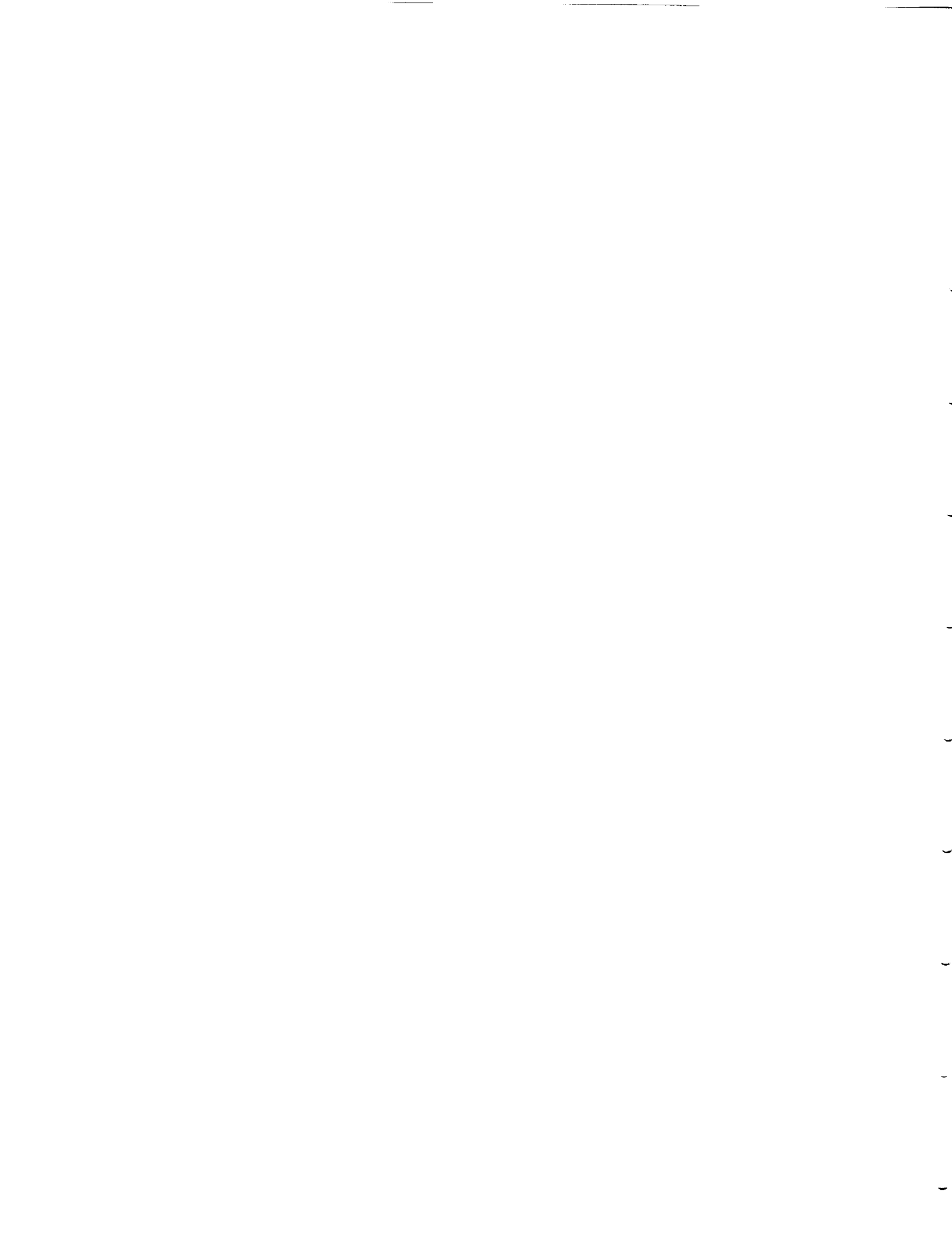

## Kinds of Objects Affected

- a. Any object of natural growth, terrain, or permanent or temporary construction or alteration, including equipment or materials used therein, and apparatus of a permanent or temporary character; and
- b. Alteration of any permanent or temporary existing structure by change of its height, or lateral dimensions, including equipment or materials used therein.

## Notice of Construction or Alterations

- a. Each sponsor who proposed any of the following construction or alteration shall notify the administrator of:
  - a1 Any construction or alteration of more than 200 feet in height above ground level at its site. Any construction or alterations of greater height than an imaginary surface extending outward and upward at one of the following slopes:
    - (i) 100 to 1 for a horizontal distance of 20,000 feet from the nearest point of the runway of each airport with at least one runway more than 3,200 feet in actual length, excluding heliports.
    - (ii) 50 to 1 for a horizontal distance of 10,000 feet from the nearest point of the nearest runway of each airport with its longest runway no more than 3,200 feet in actual length, excluding heliports.
    - (iii) 25 to 1 for a horizontal distance of 5,000 feet from the nearest point of the nearest runway of each airport.
  - a2. Any highway, railroad, or other traverse way for mobile objects, of a height which, if adjusted upward 17 feet for an interstate highway that is part of the National System of Military and Interstate Highways where overcrossings are designed for a minimum of 17 feet vertical distance, 15 feet for any other public roadway, 10 feet or the height of the highest mobile object that would normally traverse the road, whichever is greater, for a private road, 23 feet for a railroad, and for waterway or any other traverse way not previously mentioned, an amount equal to the height of the highest mobile object that would normally traverse it.
  - a3. When requested by the FAA, any construction or alteration that would be in an instrument approach area and available information indicates it might exceed a standard of obstruction standards.

- a4. Any construction or alteration on any one of the following airports (including heliports):
  - (i) An airport that is available for public use and is listed in the Airport Directory of the current Airman's Information Manual or in either the Alaska or Pacific Airman's Guide and Chart Supplement.
  - (ii) An airport under construction, that is the subject of a notice or proposal on file with the FAA, and, except for military airports, it is clearly indicated that the airport will be available for public use.
  - (iii) An airport that is operated by the US Armed Forces
- b. Each sponsor who undertakes construction or alteration that is the subject of a notice under (a), within 5 days after that construction or alteration reaches its greatest height, submit a supplemental notice to the FAA regional office, if:
  - (i) The construction or alteration is more than 200 feet above the surface level of its site; or
  - (ii) An FAA regional office advises him that submission of the form is required.

#### Construction or Alteration Not Requiring Notice

No person is required to notify the Administrator for any of the following construction or alterations:

- a. Any object that would be shielded by existing structures of a permanent and substantial character or by natural terrain or topographic features of equal or greater height, and would be located in the congested area of a city, town or settlement where it is evident beyond all reasonable doubt that the structure so shielded will not adversely affect safety in air navigation.
- b. Any antenna structure of 20 feet or less in height except one that would increase the height of another antenna structure.
- c. Any air navigation facility, airport visual approach or landing aid, aircraft arresting device, or meteorological device, of a type approved by the Administrator, or an appropriate military service on military airports, the location and height of which is fixed by its functional purpose.

#### Standards for Determining Obstructions (Figure M.1)

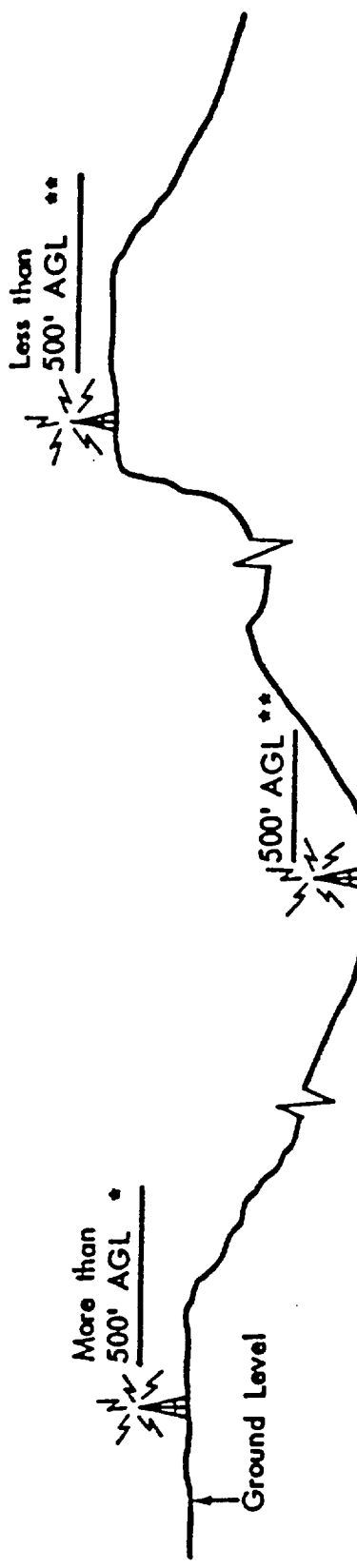

- \* Obstruction to Air Navigation
- \*\* Not an Obstruction to Air Navigation

SUBPART C - OBSTRUCTION STANDARDS

§77.23(a)(1) - An object would be an obstruction to air navigation if of greater height than 500 feet above ground level at its site.

Figure M.1 Obstruction standard anywhere.

- a. An existing object, including a mobile object is, and a future object would be, and obstruction if it is greater in height than any of the following objects:
  - (i) A height of 500 feet above ground level at the site of the object.
  - (ii) A height that is 200 feet above ground level or above the established airport elevation, whichever is higher, within 3 nautical miles of the established reference point of an airport, excluding heliports, with its longest runway more than 3,200 feet in actual length, and that height increases in the proportion of 100 feet for each additional nautical mile of distance from the airport up to a maximum of 500 feet.
  - (iii) A height within a terminal obstacle clearance area, including and initial approach segment, a departure area, and a circling approach area, which would result in the vertical distance between any point on the object and an established minimum instrument flight altitude within that area or segment to be less than the required obstruction clearance.
  - (iv) A height within an enroute clearance area, including turn and termination areas, of a federal airway or approved off-airway route, that would increase the minimum obstacle clearance altitude.
- b. Except for traverse ways on or near an airport with an operative ground traffic control service, furnished by an air traffic control tower or by the airport management and coordinated with the air traffic control service, the standards of (a) apply to traverse ways with the air traffic control service, the standards of (a) apply to traverse ways used or to be used for the passage of mobile objects only after the heights of these traverse ways are increased by:
  - (i) Seventeen feet for and interstate highway that is part of the National System of Military and Interstate Highways where overcrossings are designed for a minimum of 17 feet vertical distance.
  - (ii) Fifteen feet for any other public roadway
  - (iii) Ten feet or the height of the highest mobile object that would normally traverse the road, whichever is greater, for a private road.
  - (iv) Twenty three feet for a railroad.
  - (v) For a waterway or any other traverse way not previously mentioned, an amount equal to the height of the highest mobile object that would normally traverse it.



## Civil Airport Imaginary Surfaces

The civil airport imaginary surfaces are established with relation to the airport and to each runway. The size of each such imaginary surface is based on the category of each runway according to the type of approach available or planned for that runway. The slope and dimension of the approach surface applied to each end of a runway are determined by the most precise approach existing or planned for that runway end.

a. Horizontal surface:

A horizontal plane 150 feet above the established airport elevation, the perimeter of which is constructed by swinging arcs of specified radii from the center of each end of the primary surface of each runway of each airport and connecting the adjacent arcs by lines tangent to those arcs. The radius of each arc is:

- (i) 5,000 feet for all runway designated as utility or visual;
- (ii) 10,000 feet for all other runways.

b. Conical surface:

A surface extending outward and upward from the periphery of the horizontal surface at a slope of 20 to 1 for a horizontal distance of 4,000 feet.

c. Primary surface:

A surface longitudinally centered on a runway. When the runway has a specially prepared hard surface, the primary surface extends 200 feet beyond each end of that runway; however, when the runway has no specially prepared hard surface, or planned hard surface, the primary surface ends at each end of that runway. The wide of a primary surface is:

- (i) 250 feet for utility runways having only visual approaches.
- (ii) 500 feet for utility runways having non-precision instrument approaches
- (iii) For other than utility runways the width is:  
500 feet for visual runways having only visual approaches; 500 feet for non-precision instrument runways having visibility minimums greater than three-fourths statute miles; or 1,000 feet for a non-precision instrument runway having a non-precision instrument approach with visibility minimums as low as three-fourths of a statute mile, and for precision instrument runways.

d. Approach surface:

A surface longitudinally centered on the extended runway centerline and extending outward and upward from each end of the primary surface.

- (i) The inner edge of the approach surface is the same width as the primary surface and its expands uniformly to a width of:

1,250 feet for the end of a utility runway with only visual approaches; 1,500 feet for that end of a runway other than a utility runway with only visual approaches; 2,000 feet for that end of a utility runway with a non-precision instrument approach; 3,500 feet for that end of non-precision instrument runway other than utility, having visibility minimum greater than three-fourths of a statute mile; 4,000 feet for that end of a non-precision instrument runway, other than utility, having a non-precision instrument approach with visibility minimums as low as three-fourths statute mile; and 16,000 feet for precision instrument runways.

- (ii) The approach surface extends for a horizontal distance of:

5,000 feet at a slope of 20 to 1 for all utility and visual runways; 10,000 feet at a slope of 34 to 1 for all non-precision instrument runways other than utility; and 10,000 feet at a slope of 50 to 1 with an additional 40,000 feet at a slope of 40 to 1 for all precision instrument runways.

- (iii) The outer width of an approach surface to an end of a runway will be that width prescribed for the most precise approach existing or planned for that runway end.

e. Transitional surface:

These surfaces extend upward and outward at right angles to the runway centerline and the runway centerline extended at a slope of 7 to 1 from the sides of the primary surface and from the sides of the approach surfaces. Transitional surfaces for those portions of the precision approach surface which project through and beyond the limits of the conical surface, extend a distance of 5,000 feet measured horizontally from the edge of the approach surface and at right angles to the runway centerline.

Military Airport Imaginary Surface (Figures M.2 and M.3)

- a. Related to airport reference points. These surfaces apply to all military airports.

- (i) Inner horizontal surface:

A plane is oval in shape at a height of 150 feet above the established airfield

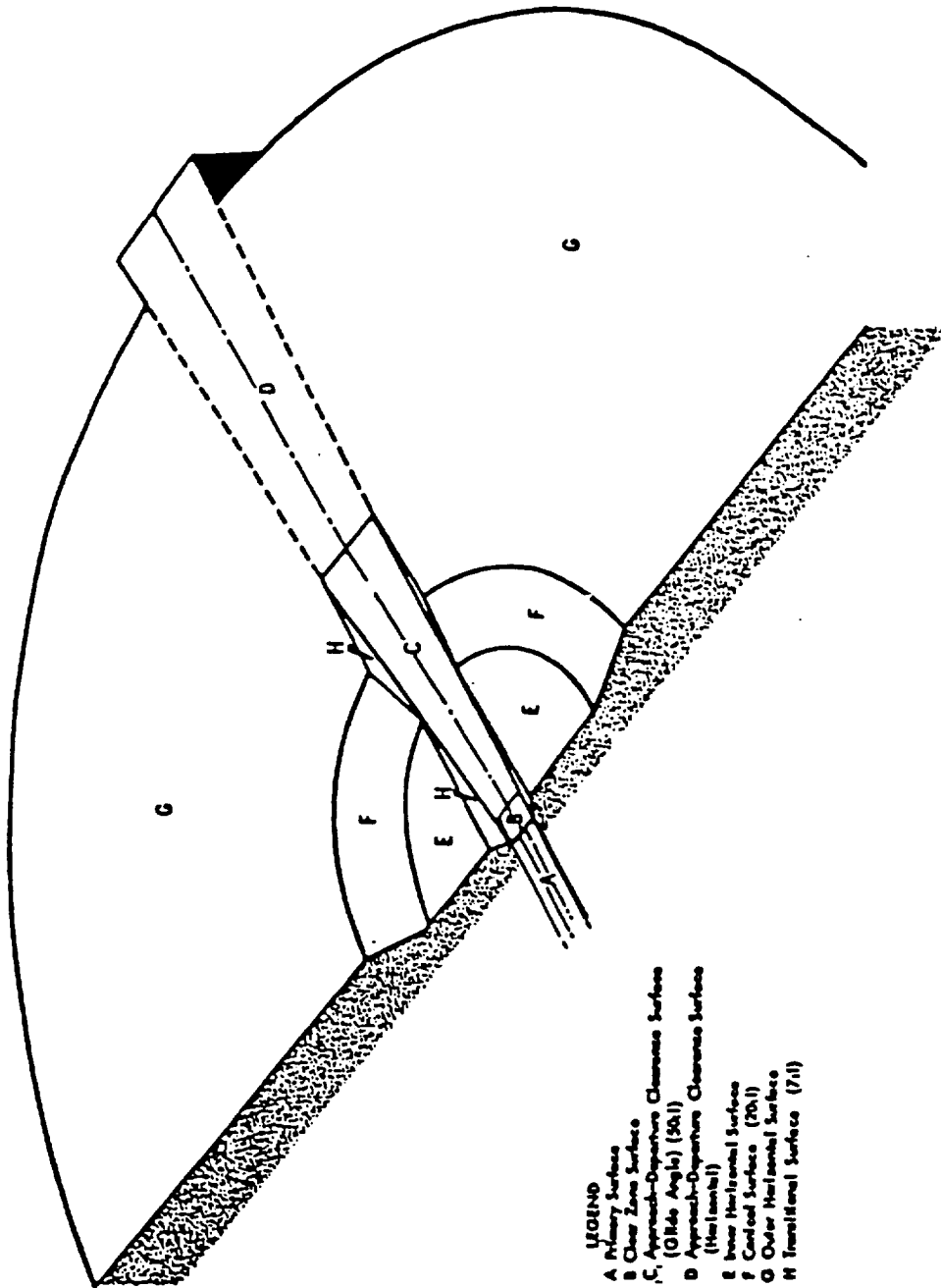

- LEGEND**
- A Military Surface
  - B Clear Zone Surface
  - C, Approach-Departure Clearance Surface (50:1) (80° Angle)
  - D Approach-Departure Clearance Surface (Horizontal)
  - E Inner Horizontal Surface
  - F Central Surface (70:1)
  - G Outer Horizontal Surface
  - H Transitional Surface (7:1)

Figure M.2 Military airport imaginary surface.

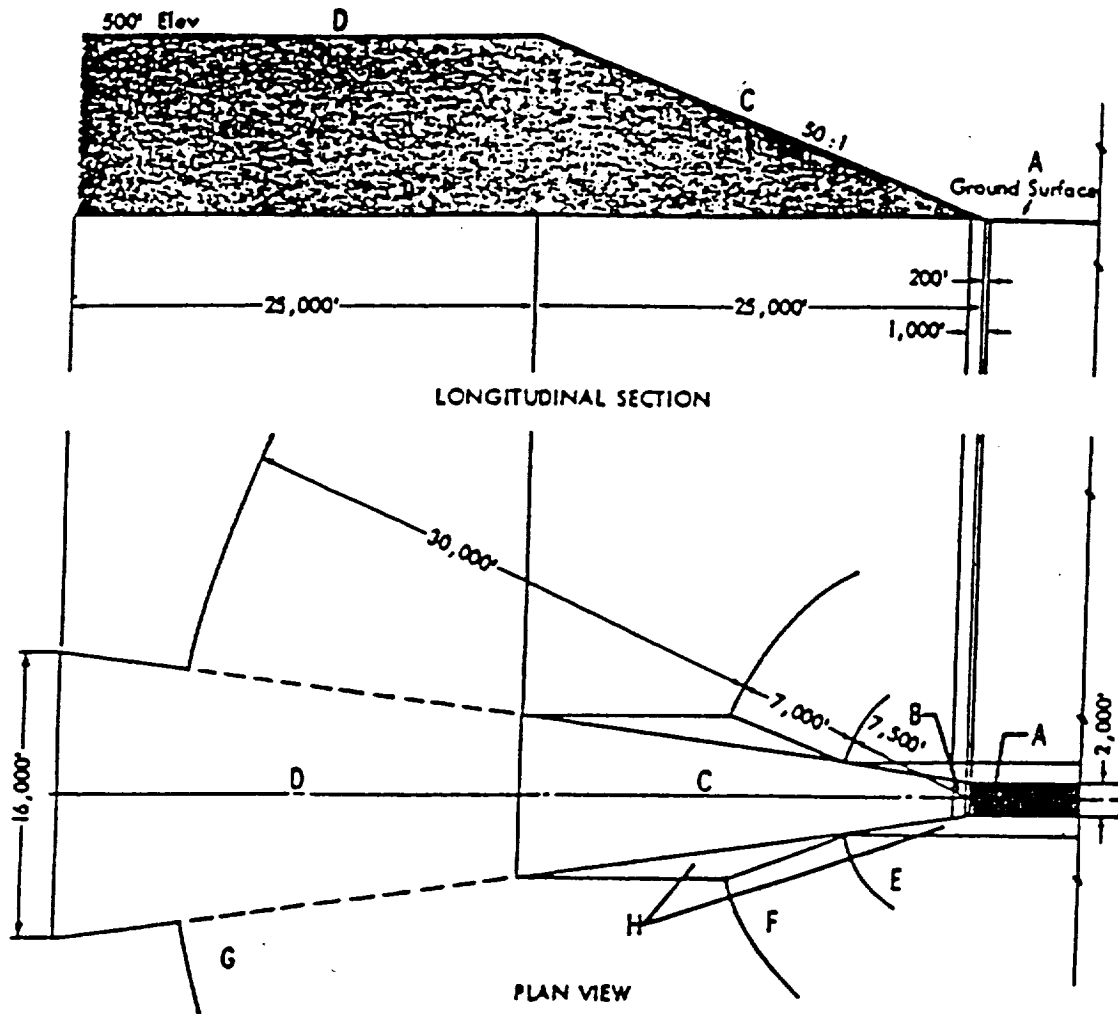

LONGITUDINAL SECTION

PLAN VIEW

LEGEND

- A Primary Surface
- B Clear Zone Surface
- C Approach-Departure Clearance Surface (Glide Angle)
- D Approach-Departure Clearance Surface (Horizontal)
- E Inner Horizontal Surface
- F Conical Surface
- G Outer Horizontal Surface
- H Transitional Surface

Figure M.3 Military airport imaginary surfaces.

elevation. The plane is constructed by scribing an arc with a radius of 7,500 feet about the centerline at the end of each runway and interconnecting these arcs with tangents.

(ii) Conical surface:

A surface extending from the periphery of the inner horizontal surface outward and upward at a slope of 20 to 1 for a horizontal surface of 7,000 feet at a height of 500 feet above the established airfield elevation.

(iii) Outer horizontal surface:

A plane, located 500 feet above the established airfield elevation, extending outward from the outer periphery of the conical surface for a horizontal distance of 30,000 feet.

b. Related to runway:

(i) Primary surface:

A surface located on the ground or water longitudinally centered on each runway with the same length as the runway. The width of the primary surface for runways is 2,000 feet.

(ii) Clear zone surface:

A surface located on the ground or water at each end of the primary surface, with a length of 1,000 feet and the same width as the primary surface.

(iii) Approach clearance surface:

An inclined plane, symmetrical about the runway centerline extended, beginning 200 feet beyond each end of the primary surface at the centerline elevation of the runway end and extending 50,000 feet. The slope of the approach clearance surface is 50 to 1 along the runway centerline extended until it reaches an elevation of 500 feet above the established airport elevation. It then continues horizontally at this elevation to a point 50,000 feet from the point of beginning. The width of this surface at the runway end is the same as the primary surface, it flares uniformly, and the width at 50,000 feet is 16,000 feet.

(iv) Transitional surfaces:

These surfaces connect the primary surfaces, the first 200 feet of the clear zone surfaces, and the approach clearance surfaces to the inner horizontal surface, conical surface, outer horizontal surface or other transitional surfaces. The slope of the transitional surface is 7 to 1 outward and upward at right angles to the runway centerline.

**APPENDIX N: HIERARCHY OF CENSUS GEOGRAPHY AND  
MAJOR CONTENTS OF 1990 CENSUS**

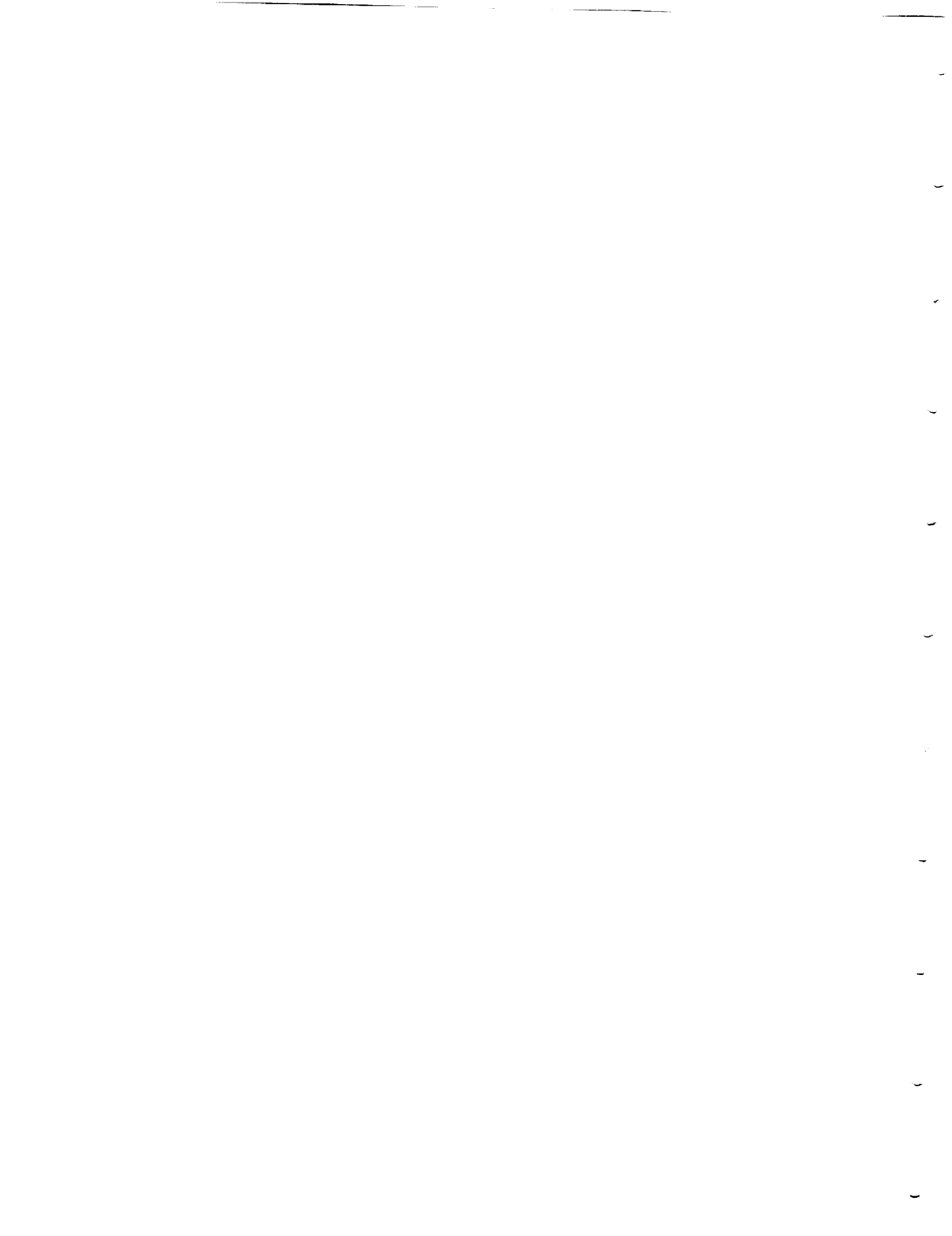



\*States - 50 and the District of Columbia

\*Counties - 3,139 plus 78 in Puerto Rico

\*Minor civil divisions (MCD's) of counties - such as townships, approximately 25,000; incorporated places, approximately 19,100.

\*Census County Divisions (CCD's) - In 20 States where minor civil divisions are not adequate for reporting subcounty census statistics, Bureau and local officials delineated 5,512 CCD's (plus 37 census subareas in Alaska) for this purpose.

\*Census Tracts - These statistical subdivisions of counties (approximately 43,350, including 463 in Puerto Rico) average 4,000 inhabitants. They are delineated (subject to Census Bureau standards) by local committees for metropolitan areas and roughly 20 other counties.

\*Block-Numbering Areas (BNA's) - Areas (approximately 3,400, including over 100 in Puerto Rico) defined for grouping and numbering blocks in areas where census tracts have not been established.

\*Block Groups (BG's) - Subdivisions of census tracts or BNA's, block groups (about 200,000) comprise all blocks with the same first digit in a tract or BNA.

\*Blocks - Generally bounded by streets or other physical features, blocks (approximately 2.5 million) are identified (numbered) in and adjacent to urbanized areas, most incorporated places of 10,000 or more population, and other areas that contracted with the Census Bureau to collect data at the block level.

#### Metropolitan Areas

\*Standard Metropolitan Statistical Areas (SMSA's) - A SMSA is comprised of one or more counties around a central or urbanized area with 50,000 or more inhabitants. There were 323 SMSA's, including 4 in Puerto Rico.

\*Metropolitan Statistical (MSA's) - On June 30, 1983, SMSAs were redesignated as Metropolitan Statistical Areas (MSAs).

\*Urbanized areas (UA's) - A UA (there were 373, including 7 in Puerto Rico) consists of a central city and surrounding densely settled territory with a combined population of 50,000 or more inhabitants

\*Metropolitan/non-metropolitan - "Metropolitan" includes all population within MSA's, "non-metropolitan" comprises everyone elsewhere.

\*Urban/rural - The urban population consists of all persons living in urbanized areas and

in places of 2,500 or more inhabitants outside these areas. All other population is classified as rural.

Population Characteristics

Age

Sex

Race

Marital status

Hispanic origin

Household relationship

Social Characteristics

Education--enrollment & attainment

Place of birth, citizenship, & year of entry

Ancestry

Language spoken at home

Migration (residence in 1985)

Disability

Fertility

Veteran status

Economic characteristics

Labor force

Occupation, industry, and class of worker

Place of work & journey to work

Work experience in 1989

Income in 1989

Year last worked

Source: U.S. Department of Commerce, Census Catalog and Guide 1991, Bureau of Census, June, 1990, p.164.

Housing  
Number of units in structure  
Number of rooms in unit  
Tenure-owned or rented  
Congregate housing  
(Meals included in rent)  
Value of home or monthly rent  
Vacancy characteristics  
Year moved into residence  
Number of Bedrooms  
Plumbing and kitchen facilities  
Telephone in unit  
Vehicle available  
Heating fuel  
Source of water and method of sewage disposal  
Year structure built  
Condominium status  
Farm residence  
Shelter costs, including utilities

Source: U.S. Department of Commerce, Census Catalog and Guide 1991, Bureau of  
Census, June, 1990, p.164.

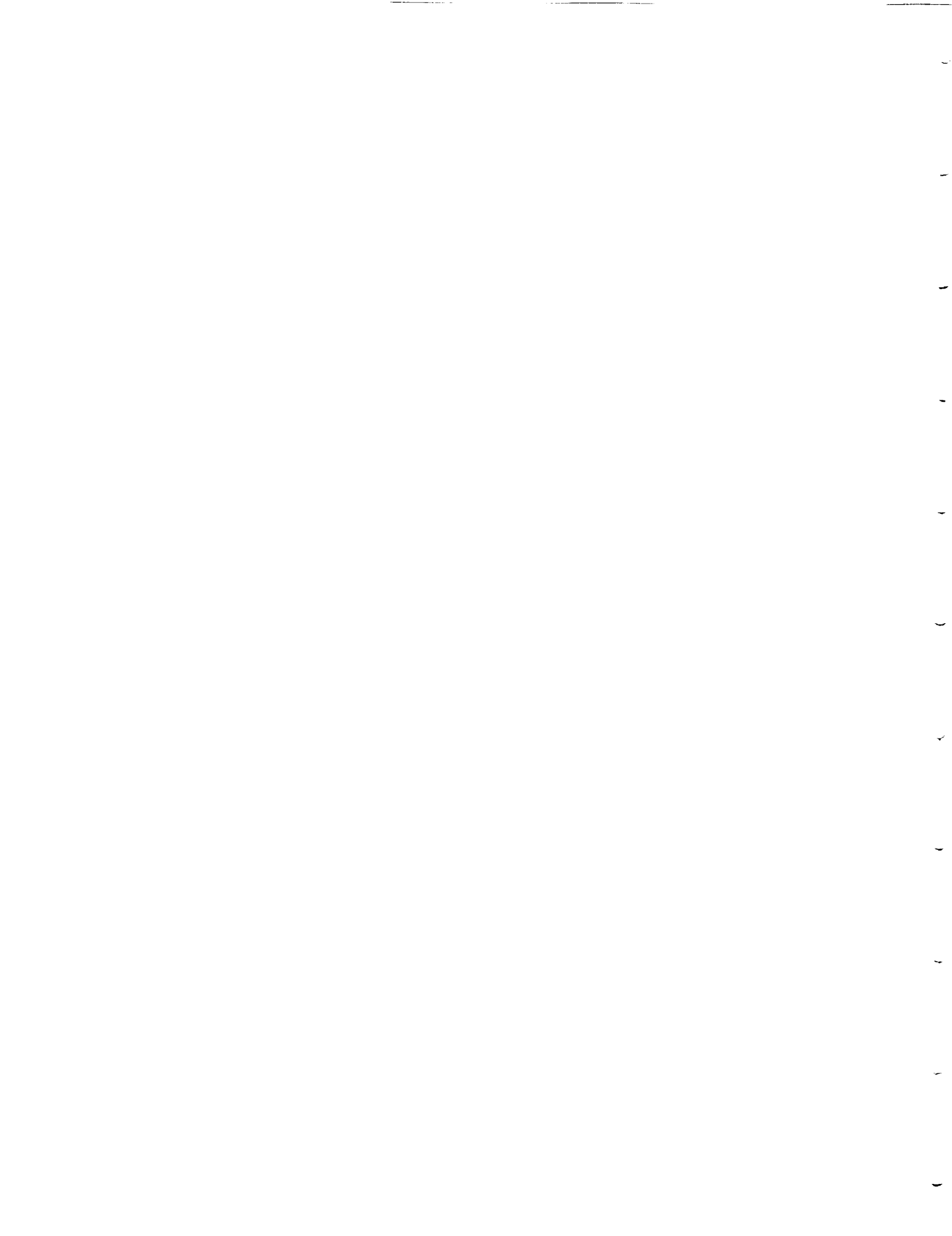

APPENDIX O: 1990 CENSUS OF POPULATION AND HOUSING REPORTS

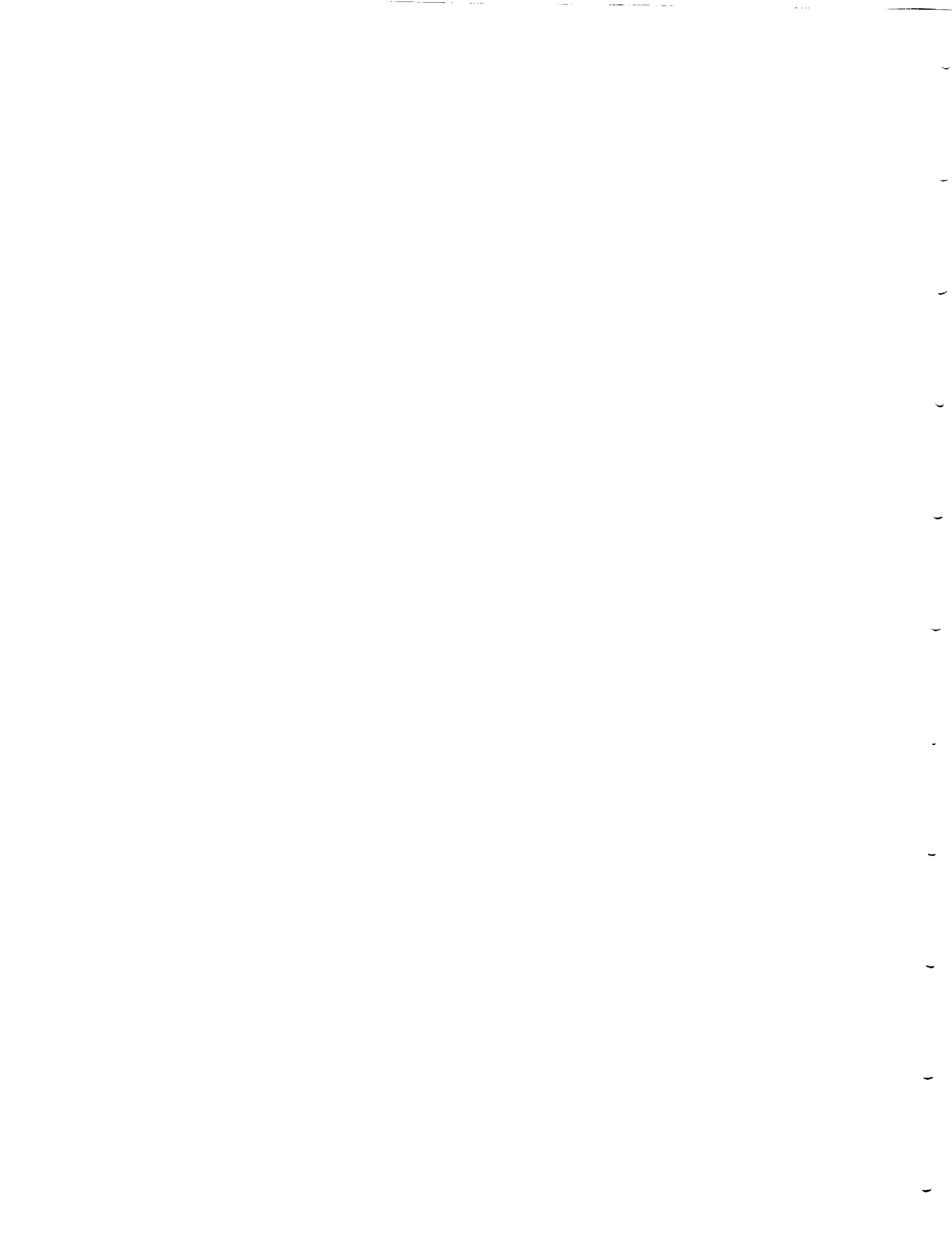

<u>Report Series</u>	<u>Year(s)</u>	<u>Report Title</u>
CPH-1-	State reports: 1991-1992  U.S. Summary: 1992	General Population Characteristics: This report provides total population and housing unit counts as well as summary statistics on age, sex, race, Hispanic origin, household relationship, units in structure, value, rent, number of rooms, tenure, and vacancy characteristics.
CPH-2-	State reports: 1991-1992  U.S. Summary: 1992	Population & Housing Unit Counts: This report provides total population and housing unit counts for 1990 and previous censuses. Data will be shown for States, counties, minor civil divisions ("")/census county divisions (CCDs), places, State component parts for MSAs and UAs, and summary geographic areas (eg. urban and rural, and metropolitan and non-metropolitan residence).

<u>Report Series</u>	<u>Year</u>	<u>Report Title</u>
CPH-3-	1991-1992	Population & Housing Characteristics for Census Tracts and Block Numbering Areas.
CPH-4-	1992-1993	Population & Housing Characteristics for Congressional Districts of the 103rd Congress.
CPH-5-	State Report: 1992  U.S. Summary: 1993	Summary Social, Economic, and Housing Characteristics. These reports will provide sample population and housing data for local governments, including American Indian and Alaska Native areas.  1990 Census of Population (1990 CP)

<u>Report Series</u>	<u>Year</u>	<u>Report Title</u>
CP-1-	State reports: 1991-1992  U.S. Summary: 1992	General Population Characteristics: Detailed statistics on age, sex, Hispanic origin, marital status, & household relationship will be presented for States, counties, places and .
CP-1A	1992	General Population Characteristics for American Indian and Alaska Native Areas.
CP-1-1B	1992	General Population Characteristics for Metropolitan Statistical Areas.
CP-1-1C	1992	General Population Characteristics for Urbanized Areas.
CP-2-	State reports: 1993  U.S. Summary: 1993	Social & Economic Characteristics These reports will focus on population subjects.
CP-2-1A	1993	Social and Economic Characteristics for American Indian and Alaska Native areas.
CP-2-1B	1993	Social and Economic Characteristics for Metropolitan Statistical Areas.
CP-2-1C	1993	Social and Economic Characteristics for Urbanized Areas.
CP-3-	1993	Population Subject Reports. 30 reports are planned covering subjects and subgroups. These subjects include migration, income and the older population. Geographic areas generally will include the United States, regions, and division.  1990 Census of Housing (1990 CH)



<u>Report Series</u>	<u>Year(s)</u>	<u>Report Title</u>
CH-1- State reports:	1992	General Housing Characteristics: Detailed statistics on units in structure, value and rent, number of rooms, tenure and vacancy characteristics will be presented for States, counties, places and .
	U.S. Summary: 1992	
CH-1A	1992	General Housing Characteristics for American Indian and Alaska Native Areas.
CH-1-1B	1992	General Population Characteristics for Metropolitan Statistical Areas.
CH-1-1C	1992	General Population Characteristics for Urbanized Areas.
CH-2- State reports:	1993	Detailed Housing Characteristics These reports will focus on the housing subjects.
	U.S. Summary: 1993	
CH-2-1A	1993	Detailed Housing Characteristics for American Indian and Alaska Native areas.
CH-2-1B	1993	Detailed Housing Characteristics for Metropolitan Statistical Areas.
CH-2-1C	1993	Detailed Housing Characteristics for Urbanized Areas.
C-3-	1993	Housing Subject Reports. 10 reports are planned for 1990 covering items such as structural characteristics and space utilization. Geographic areas generally will include the United States, regions, and division.

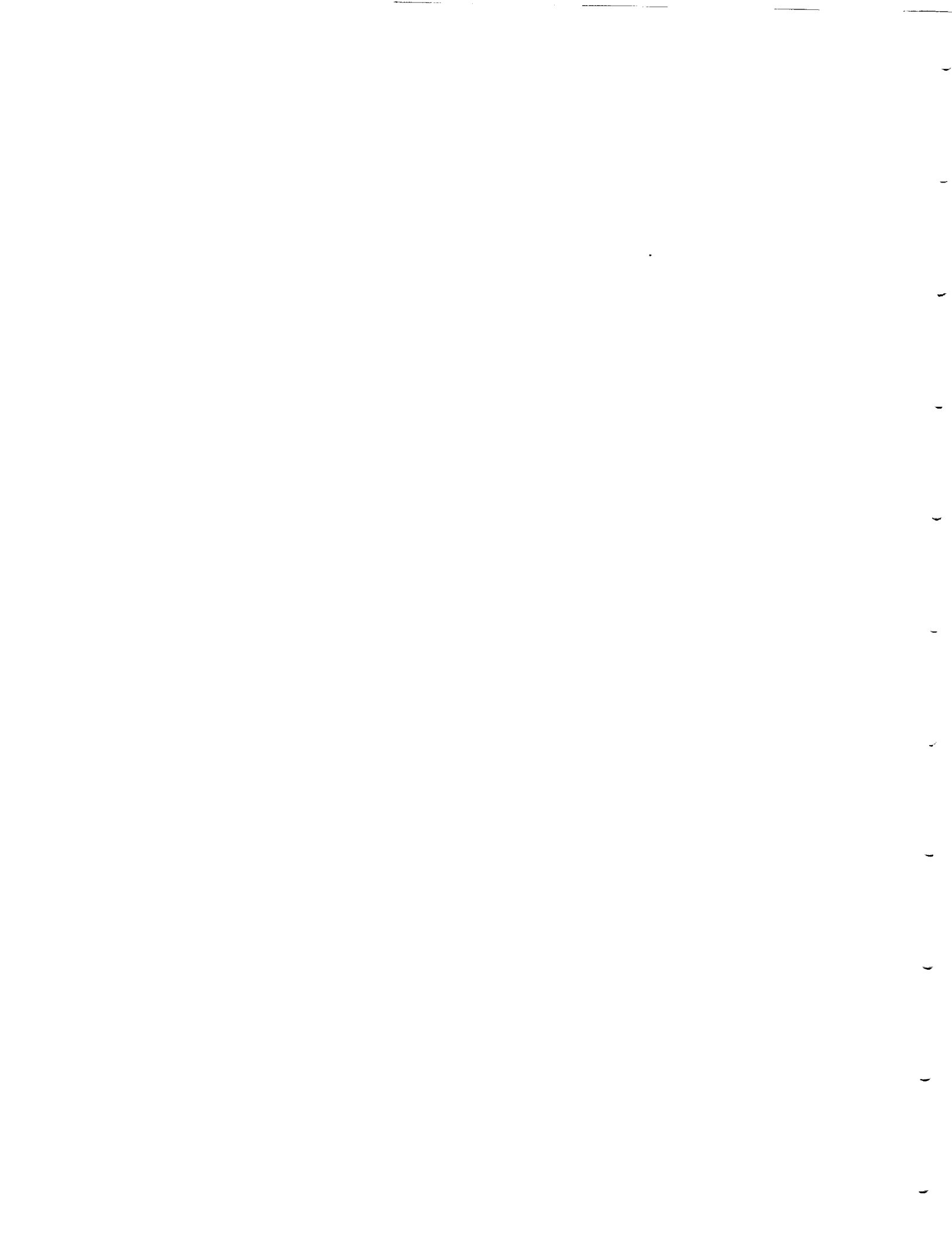

APPENDIX P: AIR QUALITY DATA BASES

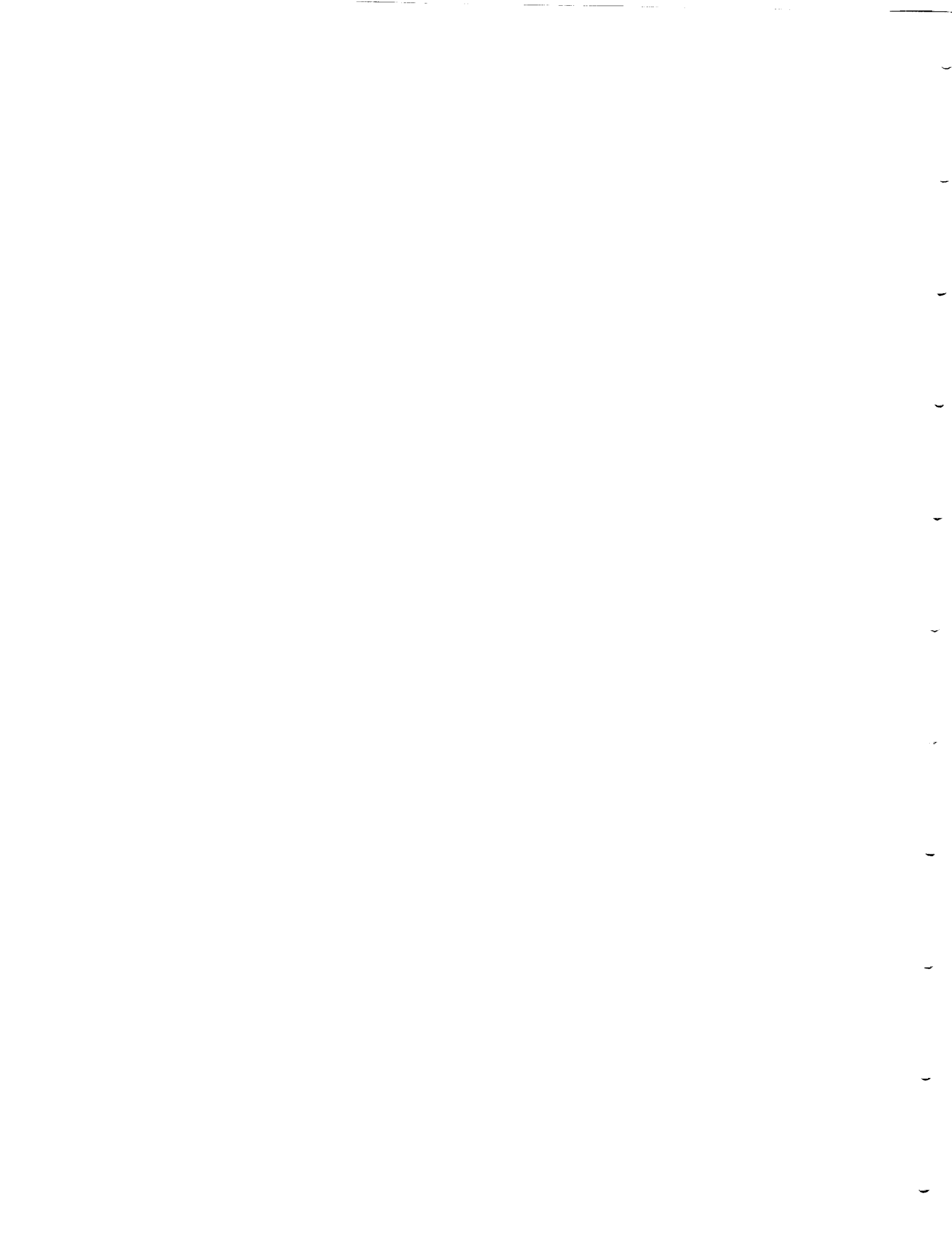

AVAILABLE DATA BASES: The only data base used by the EPA to document regional air quality and point emission is:

-Aerometric Information Retrieval System (A.I.R.S).

#### Summary of Data Information

The EPA provides air-quality information to the public through the freedom of information office. The Aerometric Information Retrieval System(AIRS) provides information of non-attainment for specified pollutants in designated areas. AIRS also provides point emission levels for producers of contaminants. The Clean Air Act requires cities to maintain certain acceptable levels (National Ambient Air Quality Standards) in air quality for a variety of pollutants including: lead, carbon dioxide, carbon monoxide, ozone, and sulfur. If cities do not maintain these specified levels for air quality Federal penalties will incur. Each state must maintain data information for specific sites. These data are shared with the EPA [9.9].

The AIRS data base can be applied in a GIS system. The information the AIRS system provides are listed by counties; and specific monitor sites positional coordinates are provided. The EPA will provide the data on magnetic tape in numerous formats [9.10].

Airports contribute to the overall air quality of a region, but at this time, airport are not considered single point sources of pollutants. If this definition changes and the airport environment is considered to be a single point source, new procedures may have to be implemented to control emissions. Since the information provided by A.I.R.S. only covers geographic regions encompassing cities and individual monitoring sites, it does not permit isolating the values of an airport's emissions.

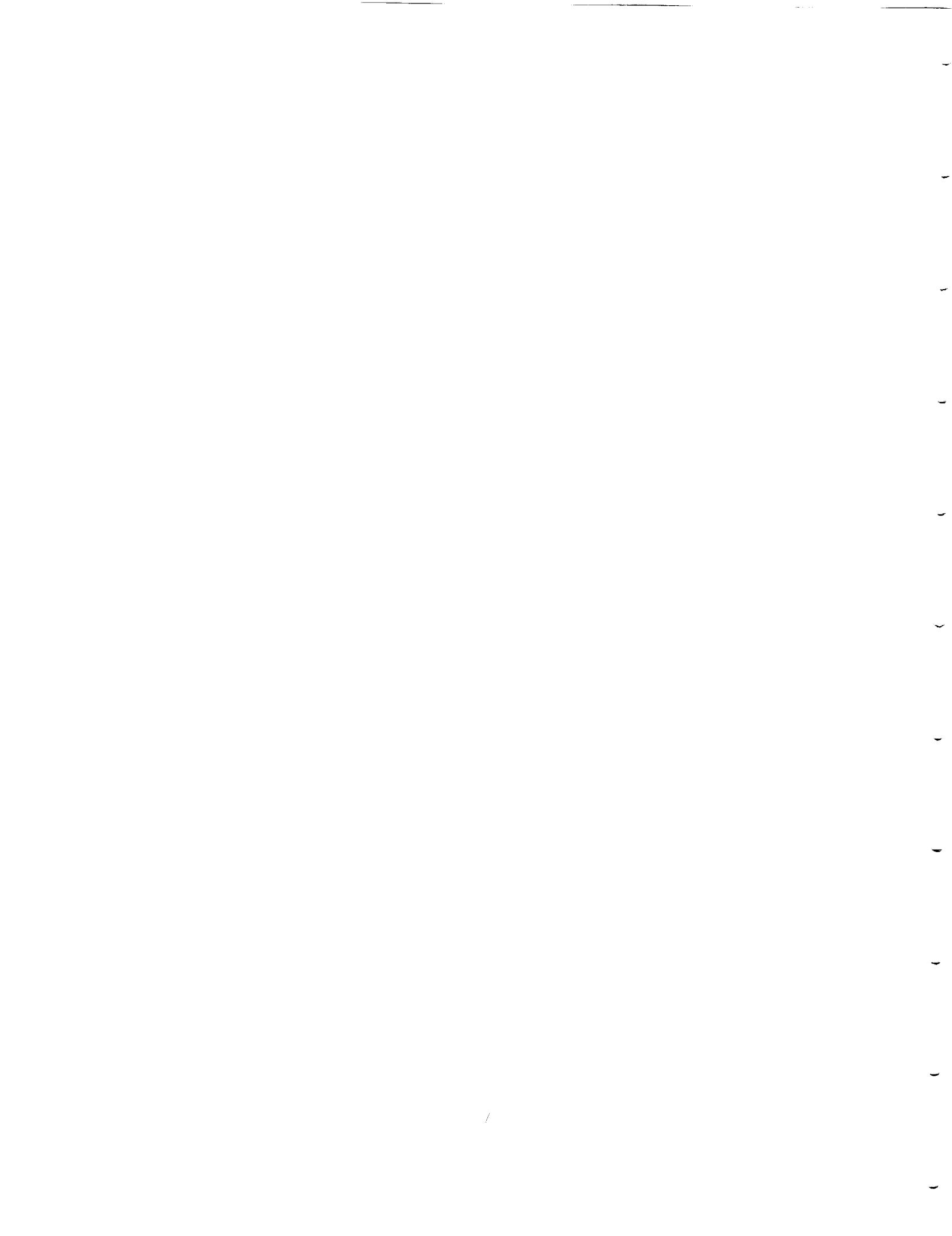

APPENDIX Q: WATER QUALITY DATA BASES

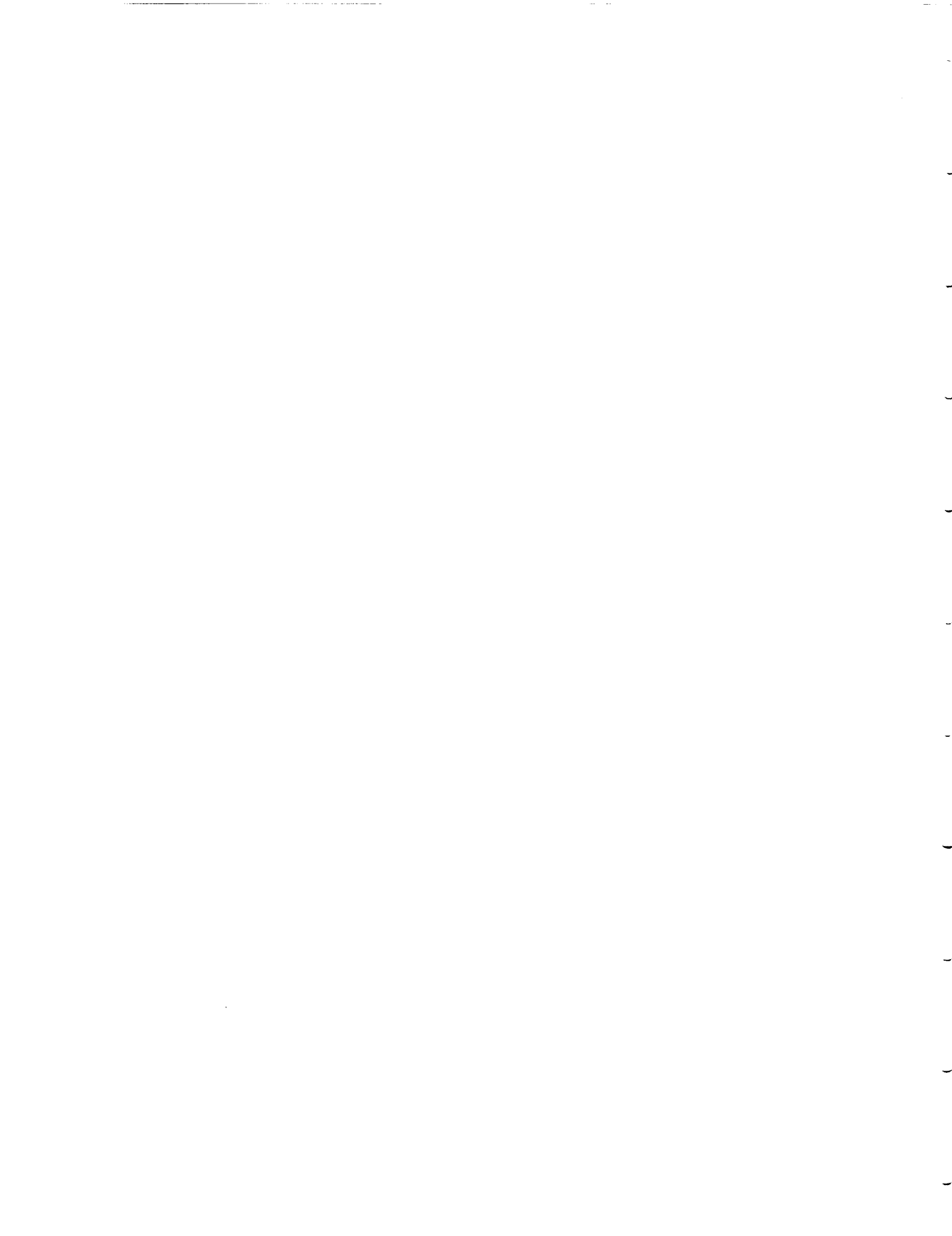



AVAILABLE DATA BASES: A large quantity of data bases are available to fully document information regarding water quality issues.

- 1) Digital Elevation Model(DEM)\*
- 2) Digital Line Graph(DLG)\*  
-Hydrography\*
- 3) Geographic Names Information System(GNIS)\*  
-Concise(abridged U.S.)\*
- 4) Land Use and Land Cover \*  
-Hydrological Units\*
- 5) National Wetlands Inventory
- 6) Master Water Data Index
- 7) Water Data Sources Directory
- 8) National Water Information System(NWIS).

#### Summary of Data Information

The Master Water Data Index (MWDI) is a data base, developed and maintained by the National Water Data Exchange (NAWDEX) Program Office. The office also contains information about water data collection sites of NAWDEX member and participants. The data provided from each monitor site includes:

- 1) The primary use of the water source either public supply, commercial, agriculture etc.
- 2) Meteorological information at each site such as: wind, evaporation, soil moisture, and precipitation
- 3) Flow levels of particular sites such as: year round peak flows, seasonal, monthly, daily levels
- 4) Ground water information such as: hydraulic conductivity, and transmissivity (The rate at which water moves through an aquifer)
- 5) Total annual pumpage or flow from each well site per year.

NAWDEX also contains information on the identification and location of sites for which water data are available, the period of time for which data are available, the major water parameters for which data are available, the frequency at which these parameters are measured, and the media on which the data are available.

The MWDI is designed to be used independently, or in conjunction with, the Water Data Sources Directory, also maintained by the NAWDEX Program Office. It contains information about organizations that are sources of water data. The data provided by the U.S. Geological Survey and the EPA contain enough information for detailed studies of potential sites for airports. All the information is given geographic references but a GIS system, to our knowledge, has not yet been established to tie all of this information together at a national level. Information about each individual state is provided by their

Department of Natural Resources, or equivalent agency, with geographical location information. Again, it appears these data are not currently used in GIS systems at the state level [9.10].

The U.S. Geological Survey also maintains the National Water Information System. NWIS is a data base that inventories ground water and water quality data from around the United States. The compatibility of these data could be a concern in creating a national GIS system for airport and air routing. Even though NWIS is geographically referenced, the data will need additional software to convert the data for use in certain Geographical Information Systems. Further information about the details in the converting software of water data to GIS are found in USGS/WRI 90-4200 by Johnethon Scott.

In addition to the water quality data, Digital Line Graphs and Digital Elevation Models could be used to determine stream and basin location and characteristics. The slope and basin drainage of stream systems must be documented to understand the potential impact and airport would have on an area. The Geographic Names System will locate streams and water bodies valuable for evaluation. The Land-use and Land Cover Data could be used to evaluate the existing and potential runoff caused by impervious surfaces related to human development.

APPENDIX R: PUBLIC LANDS DATA BASES

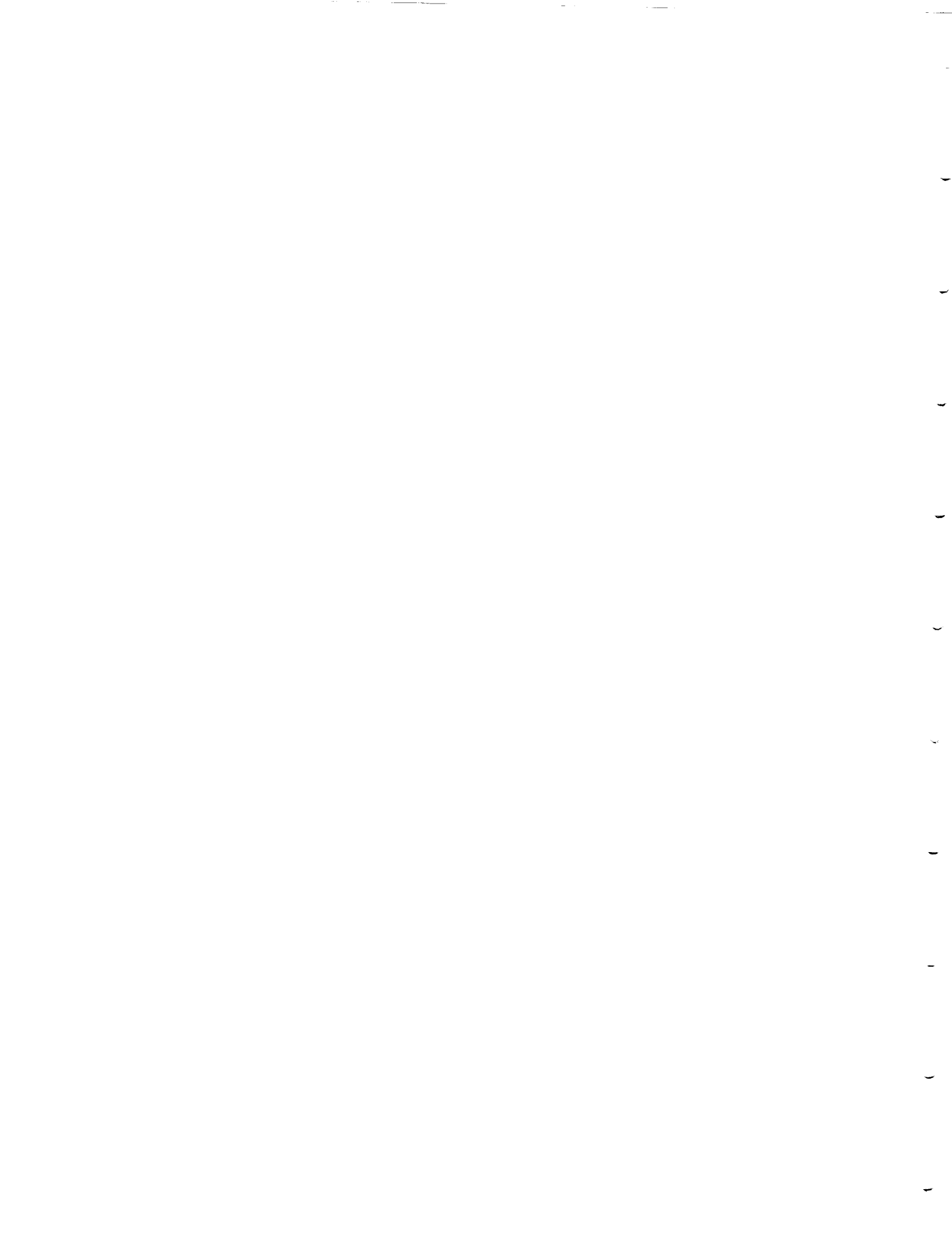

AVAILABLE DATA BASES: The data bases listed below will enhance any survey of public lands.

- 1) National Park Index
- 2) G.I.S. National Parks List
- 3) Digital Line Graph(DLG)\*  
-U.S.Public Land Survey\*
- 4) Geographic Names Information System(GNIS)\*
- 5) Land use and Land Cover\*  
-Land Use and Land Cover\*  
-Federal Land Ownership\*

#### Summary of Data Information

The data based on a national survey of publicly owned recreation lands are available. These data are in a format suitable for use in a GIS. Publicly owned recreation land that is protected by legislation only contribute to the development of airports and do not influence aircraft routing. The majority of publicly owned land would not be influenced by aircraft over-flight noise. However, if the use of an airport is expanded or a new airport site is proposed public recreation land could be impacted. If that is the case, a national data base with the locations and specific attributes of the publicly owned recreation land would certainly contribute to the planning of a new airport, or the expansion of an existing one. With GIS and the available data bases, stated above, the airport authority could eliminate all sites that are protected by the Department of Transportation Act section 4(f) and concentrate on other more important factors affecting location.

The National Park Service is concerned with the existing patterns of aircraft overflights and the effects of noise on visitors. The airways over the national parks are getting more crowded. In 1987 the Federal government set forth Public Law 100-91 to require the National Park Service to initiate studies on aircraft noise impact on National Parks visitors. Figure 9.3 illustrates the current flight regulations over the Grand Canyon. If the noise studies conclude aircraft have a negative impact on National Parks, then restrictions may be imposed for all major parks.

Currently, the National Park Service is developing a GIS system for the Grand Canyon National Park, where certain restrictions on aircraft over-flights have been put in place. The GIS system that is being developed will be used to evaluate the noise impact of different classifications of jet and propeller driven aircraft on the canyon and evaluate the noise that they produce throughout the canyon [9.3]. If the system proves to be successful it may be implemented in all other national parks.

Currently, detailed spatial data bases are available for a small percentage of parks (25%). To date 88 out of 354 national parks have developed land management systems. The quality of these data bases vary in compatibility and robustness. Some data bases

are still in Computer Aided Design (CAD) systems while others are developed using commercial GIS packages but from different vendors. A compatibility problem often arises when data bases are built using different systems. Data derived from CAD are sometimes unusable in a GIS system [9.3]. CAD systems use an internal cartesian coordinate system not inherently tied to a geographic coordinate, where as GIS uses coordinates related to location on the earth. Some newer CAD and GIS systems provide the capability to transform CAD coordinates to geographic coordinates.

In addition to the National Park data on public lands, other digital data bases are available containing public recreational land information. The Digital Line Graph's U.S. Public Land Survey documents land that is protected that would be protected by section 4(f) of the Transportation Act. The Geographic Names Information System along with the Land Use and Land Cover's Federal Land Ownership Informational System document publicly owned recreation land [9.4].

Data bases are available for public recreation lands, however coverage does not exist for all parks. The boundaries of all public lands are contained in the DLG data set, but internal detail of the land use characteristics, necessary for planning, do not exist nationwide. The trend suggest that data base development will continue for public lands.

**APPENDIX S: HISTORICAL SITES DATA BASES**

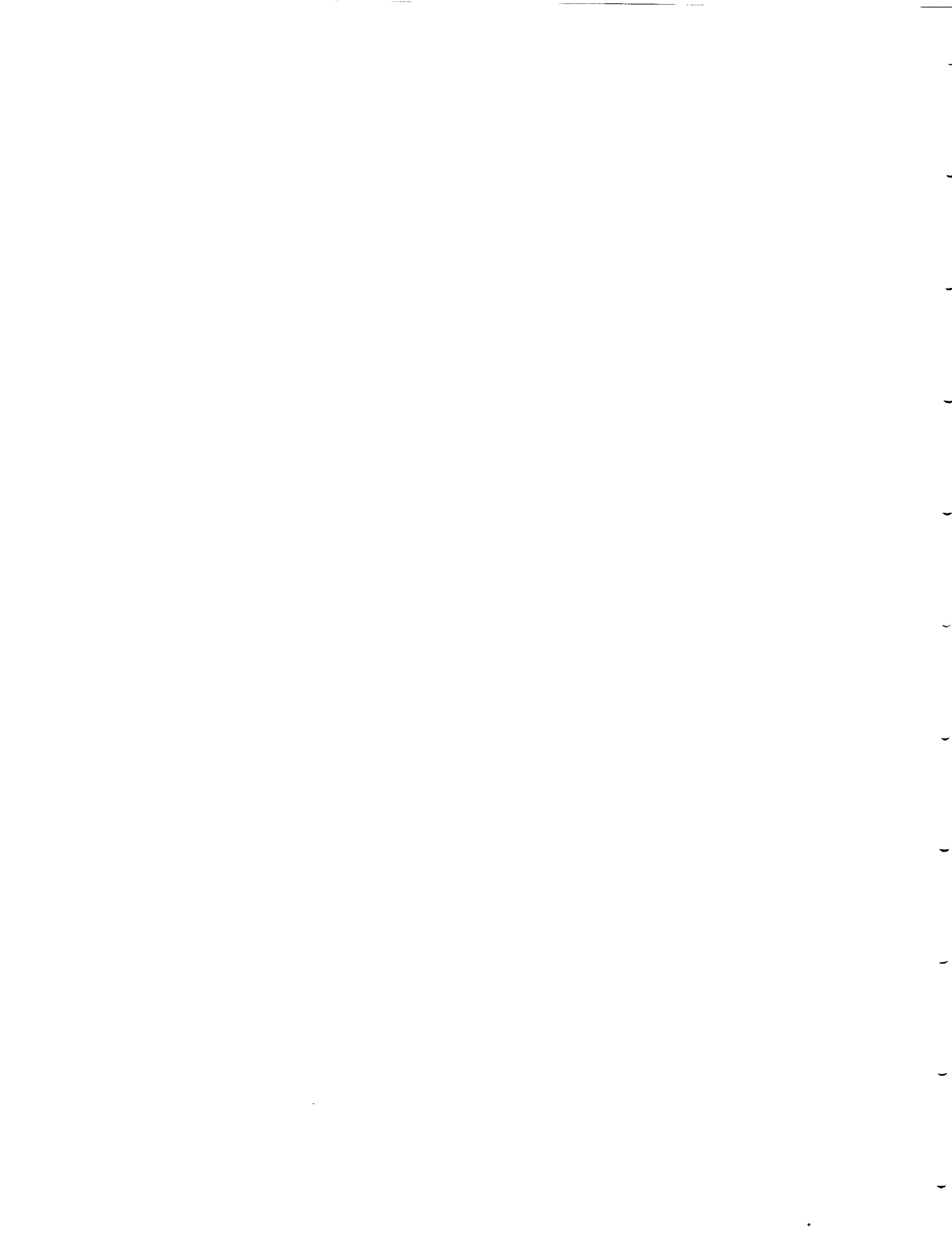



AVAILABLE DATA BASES: Two national data bases are available to be used in evaluating historical sites.

- 1) National Register of Historic Places
- 2) National Survey of Eligible Historic Sites
- 3) Examples of state data bases:
  - Georgia Register of Historic Places
  - Georgia Survey of Eligible Historic Sites

#### Summary of Data Information

The National Historic Preservation Act of 1966 and the Archeological and Historic Preservation Act of 1974 put forth strict requirements for the maintenance of these facilities. Section 106 of the Act states that federal agencies, prior to extending funds or issuing licenses, shall "take into account the effect of the undertaking on any district, site, building, structure, or object that is included in or eligible for inclusion in the National register" [9.5].

The data bases that are available list all the sites on the National register and provide their geographic location. The quality of the National Register geographic location data is being updated. Currently, only sixty percent of the data is 99% accurate [9.5]. The quality of the remaining data is deficient for a detailed study. It is presently projected that the completion of the total data base is expected within five years. The second data base provided by the national register is the eligible sites data base. The survey of eligible sites contains the site location coordinates and therefore could be integrated into a GIS system.

Section 106 requires the states to establish historic preservation offices. These offices work in a partnership with the U.S. Department of the Interior and local communities. Within each state there is a second data base for documented eligible sites. State data bases are far more extensive and should be examined when evaluating a project's impact on the historical nature of a structure or neighborhood located within the boundaries of a proposed project.

Not all eligible sites data bases contain coordinates for the site. However, an alternative exists for sites found within major urban areas. The TIGER file (See section 8), produced by the U.S. Bureau of the Census, allows for the conversion of street addresses to geographic coordinates. Once geographically referenced, these sites can be used in a GIS. Rural addresses, however, cannot be matched using the TIGER system.

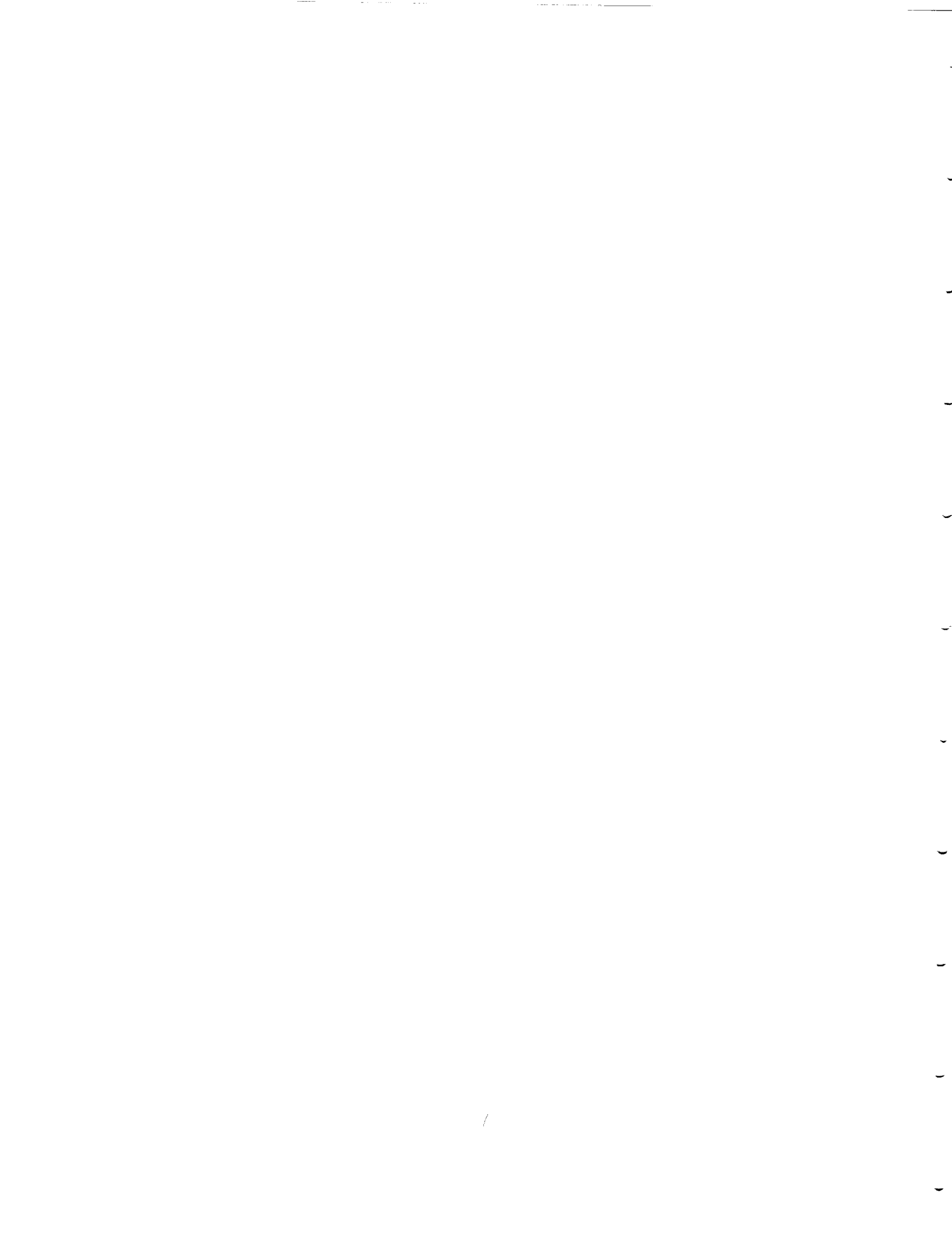

APPENDIX T: ENDANGERED SPECIES DATA BASES

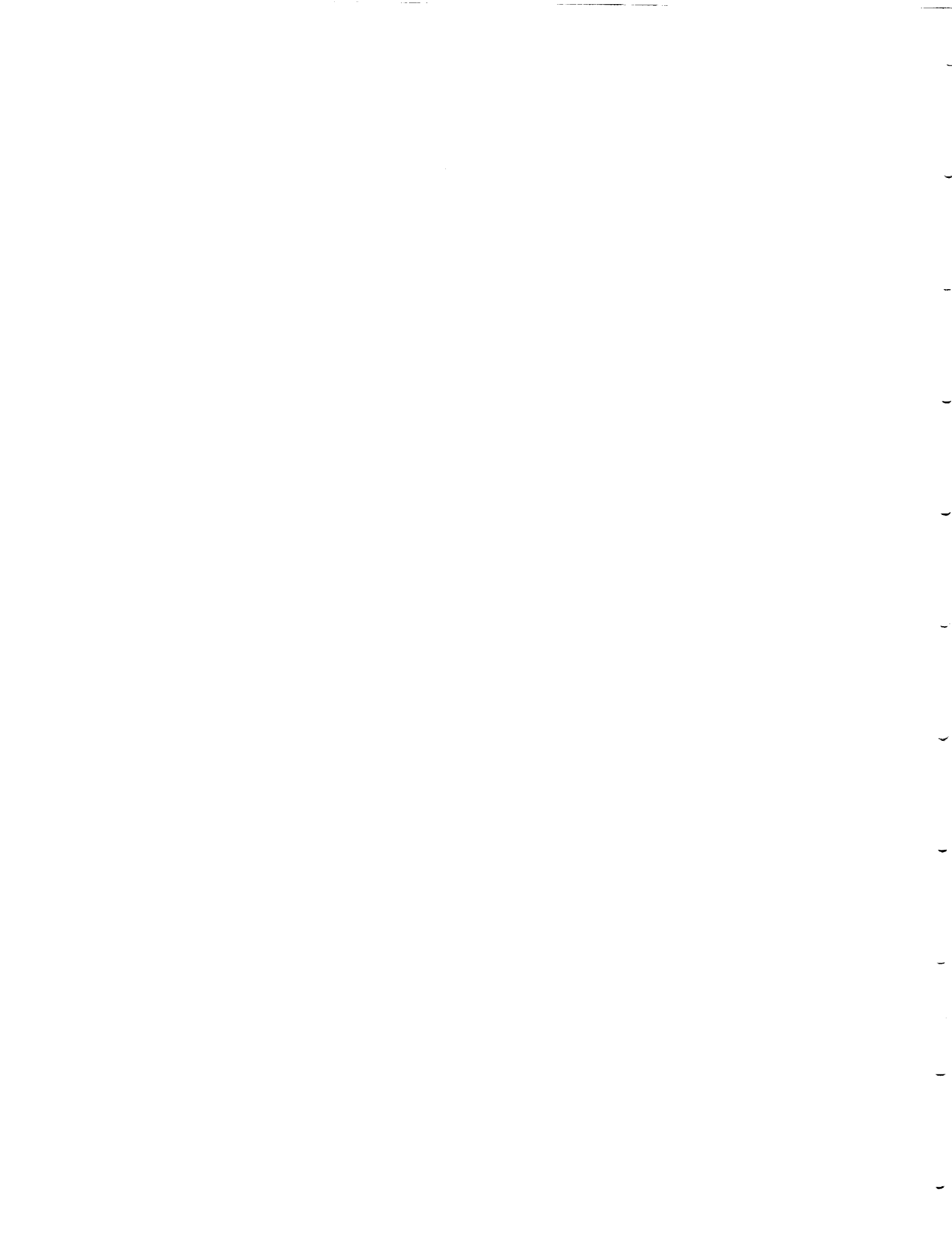

AVAILABLE DATA BASES: Unfortunately no data base is available, at a national scale, to document the specific habitat of an endangered species. However, data bases are available to derive habitat locations of certain endangered species.

- 1) U.S. Fish and Wildlife List of Endangered and Threatened Species Wildlife and Plants.
- 2) Habitat Management Guidelines For Endangered Wildlife.
- 3) Endangered Wildlife Species Recovery Plans.
- 4) Endangered Wildlife Specific Critical Habitat Sites.
- 5) State County Listing of Endangered Species occurrence.  
-Example The State of Georgia-

#### Summary of Data Information

Currently, there are no national spatial data bases available that specifically outline an endangered species habitat range. Several states have created a geographically referenced data bases for specific animals, such as the Florida Panther within the State of Florida. Critics of such data bases claim that they do not cover the full extent of unknown animals and ranges [9.12]. The existing data bases create wildlife ranges by the known location of radio tagged animals and visual sightings. There are animals that never get tagged or observed, consequently their habitat ranges are inadequately documented.

A comprehensively derived habitat range would begin to incorporate the full potential to include all endangered species. The creation of this data base must incorporate the known locations of endangered species as well as areas of wilderness distinctly capable of sustaining the animal even without documented evidence of its existence within the area. Information provided by the U.S. Fish and Wildlife Service will contribute to the development of habitat data.

The service will provide a data base of endangered and threatened species. In addition, the service has information on the occurrence per county of endangered species as well as information about each specific species environmental habitat requirements. Recovery plans and habitat management guidelines outline the specific needs of each species with information about proper management of these areas.

GIS is the tool that would be useful as a basis to achieve the creation of habitat ranges. GIS could be used to derive a habitat from the layers of information provided. Several data bases are available that would be useful in deriving habitat information. Some examples of information layers are: 1) know occurrences of habitat; 2) physical environmental quality such as wetlands; 3) temperate zone; 4) elevation; 5) proximity to human development; and 6) historic range [9.7]. An important ancillary source of information is the Habitat Management Guideline series provided by the U.S. Fish & Wildlife Service. Figure 9.7 illustrates an example of management guidelines regarding

buffers around Bald Eagle colony nesting sites.

If a comprehensive system were produced for all endangered and threatened species, the habitat data base would include vast areas of the United States. The political feasibility of creating such a data base and protecting the land therein would be highly improbable.

A GIS system could be created to mitigate political problems by calculating areas with the highest number of occurrences of different endangered species. The designation of these most frequent range overlaps as wildlife preserves would initiate the protection of these species. The State of Florida is creating such a data base by the use of remote sensing to designate the most eligible areas for preservation [9.13].

The location of specific habitat ranges have not been fully documented to the extent desired by the U.S. Fish and Wildlife Service, although the potential is certainly there for such a system.

APPENDIX U: WETLANDS DATA BASES

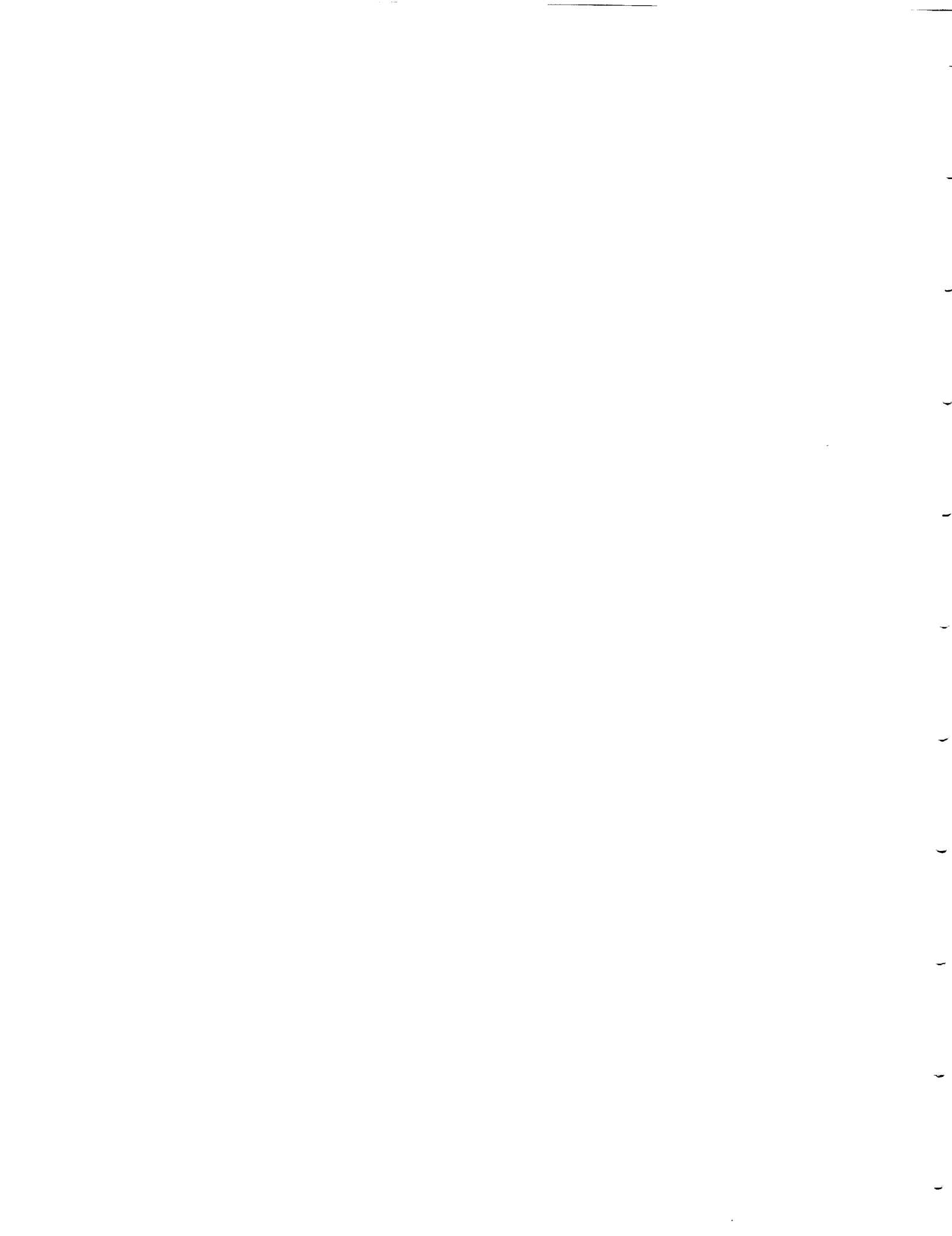



AVAILABLE DATA BASES: There is only one data base available at the national level. This data base is the source for many more local and regional wetlands maps.

1) National Wetlands Inventory-

Summary of Data Information

The National Wetlands Inventory, established by the U.S. Fish and Wildlife Service provides information in digital form as well as standard paper maps. The digital format currently contains about thirty percent of the United States while the standard maps are eighty percent finished.

At the state level, the availability of digital data varies. Most states use the data provided by the Wetlands Inventory, and any additional digital data collection depends on activities within the state and specific departments. Most departments, that have the possibility of impacting wetlands, must maintain wetlands location data for development planning. Most state highway and transportation departments do have such information. Again, the Wetlands Inventory is the primary source.

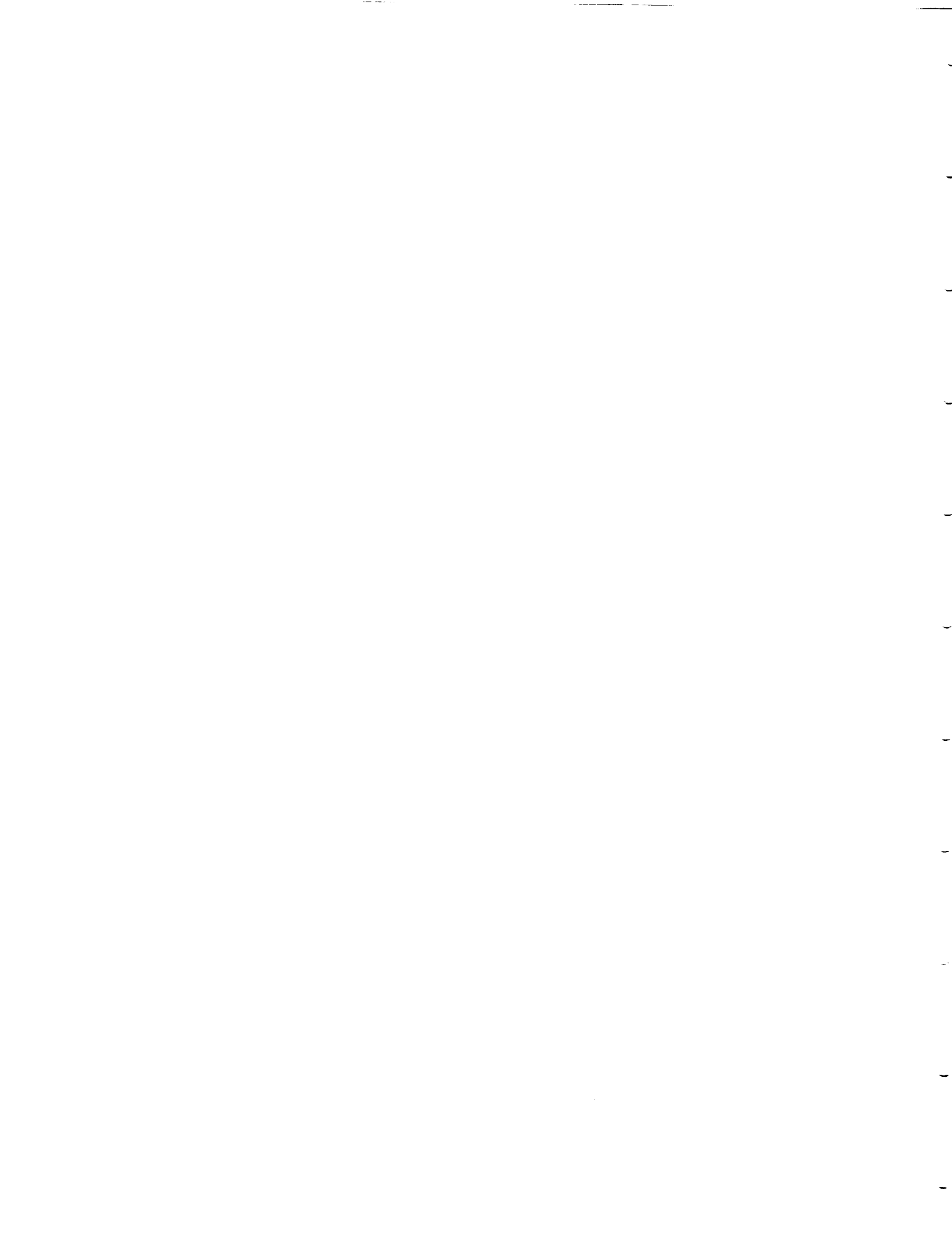

APPENDIX V: FLOOD PRONE AREAS DATA BASES

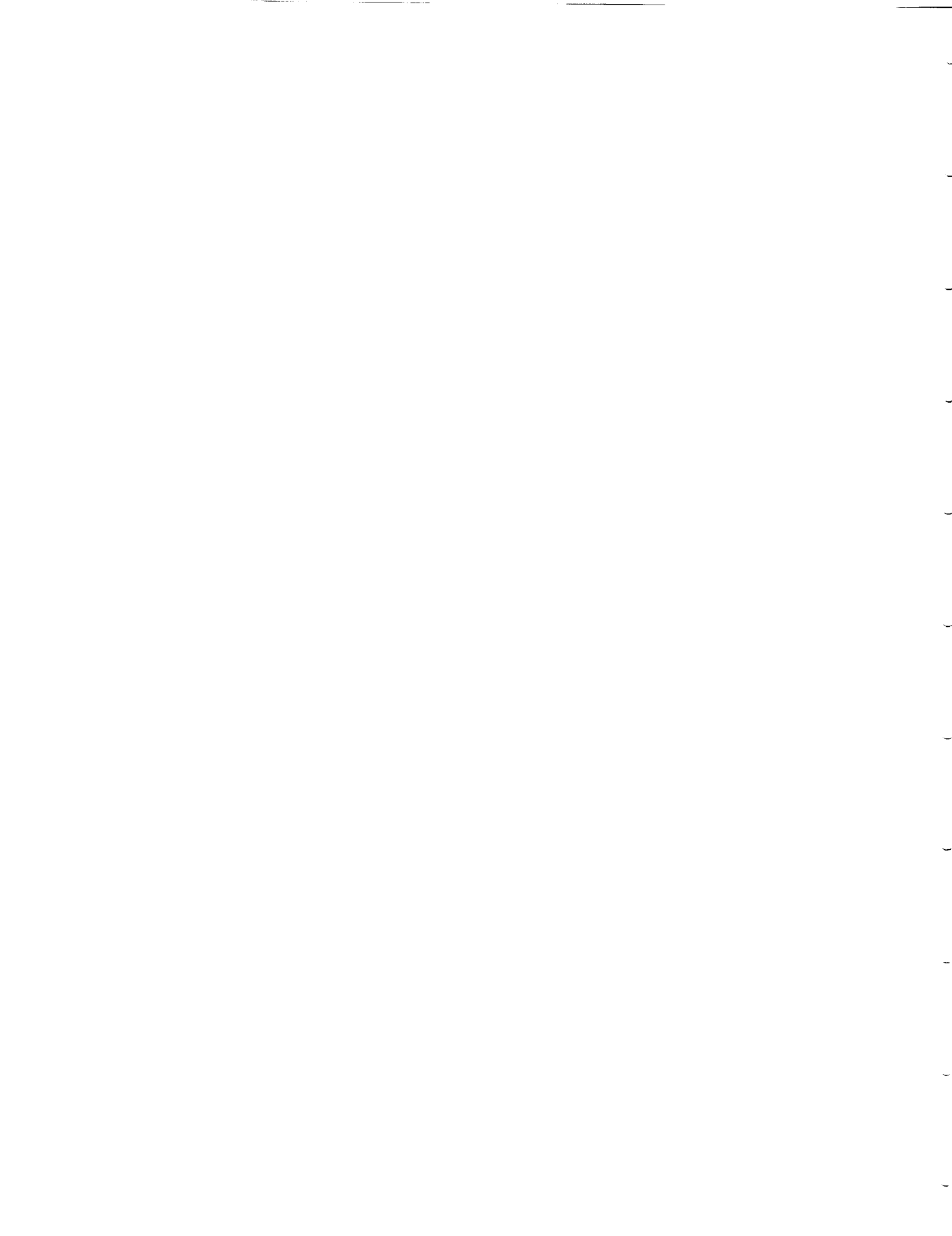

AVAILABLE DATA BASES: The Federal Emergency Management Agency along with the Corp of Engineers and the Federal Insurance Administration have map data bases for flood prone areas.

- 1) Federal Insurance Administration (FIA) Maps
- 2) Flood Insurance Rate Map
- 3) Flood Insurance Study Report
- 4) Flood Hazard Boundary Map

#### Summary of Data Information

Currently the Federal Emergency Management Agency does not provide digital maps designating flood hazard areas: however, they do provide maps for any community. These maps display the 100 and 500 year flood areas (i.e. the probability .01 to .002 of floods occurring). Creating a digital data base from the map product would be an enormous task, and the result would be of questionable accuracy. The vast coverage of these maps and the details needed to properly document floodplains, especially 500 year floods, should be questioned due to the infrequency of occurrence.

Some individual states and local communities may have more accurate information than FEMA, but the majority of regions depend on these FEMA's maps. Several communities may have digitized information on floodplains and floodway within their planning departments. These data sets are most certainly in diverse formats and therefore of limited utility in a nationwide data base.

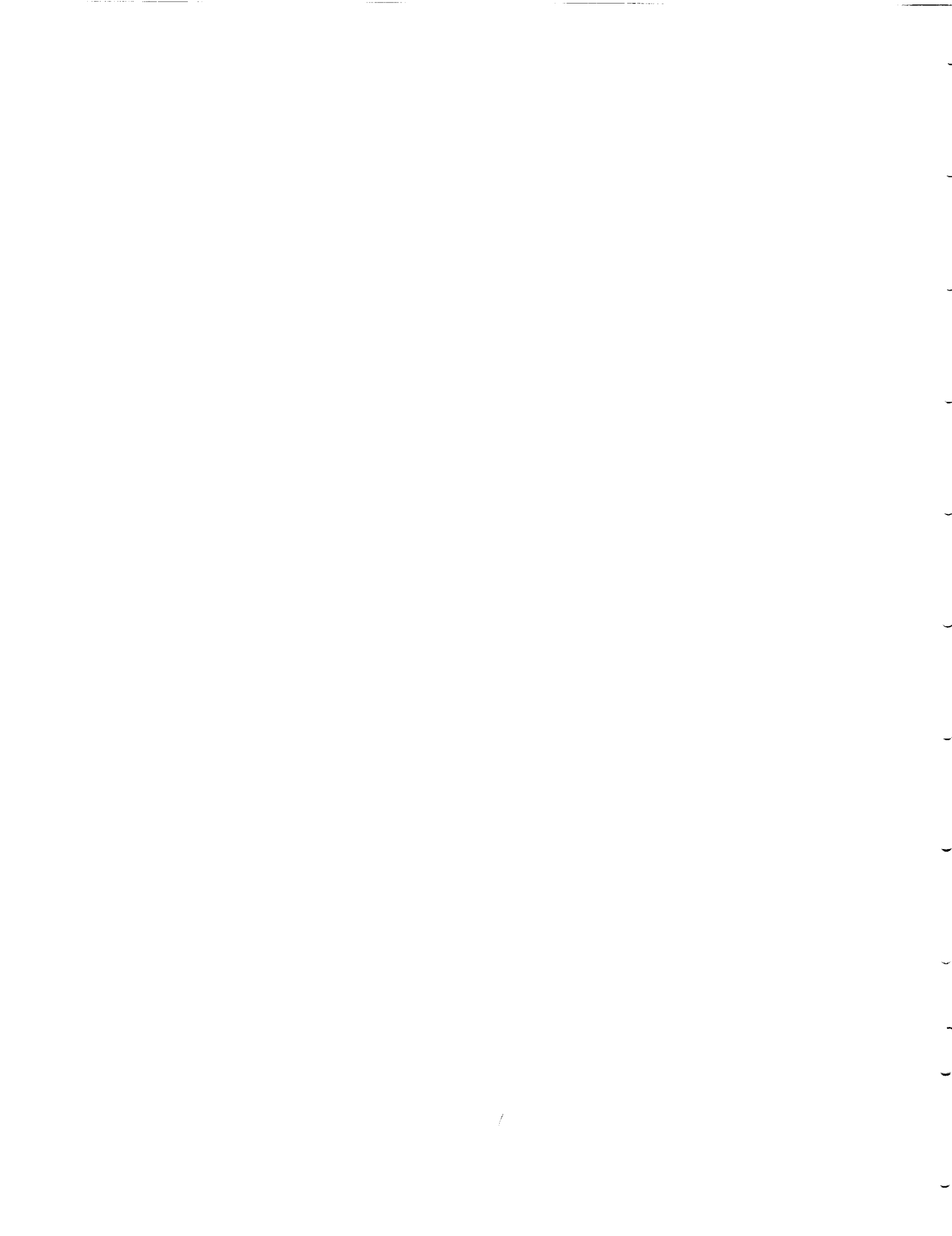

APPENDIX W: COASTAL BARRIER DATA BASES

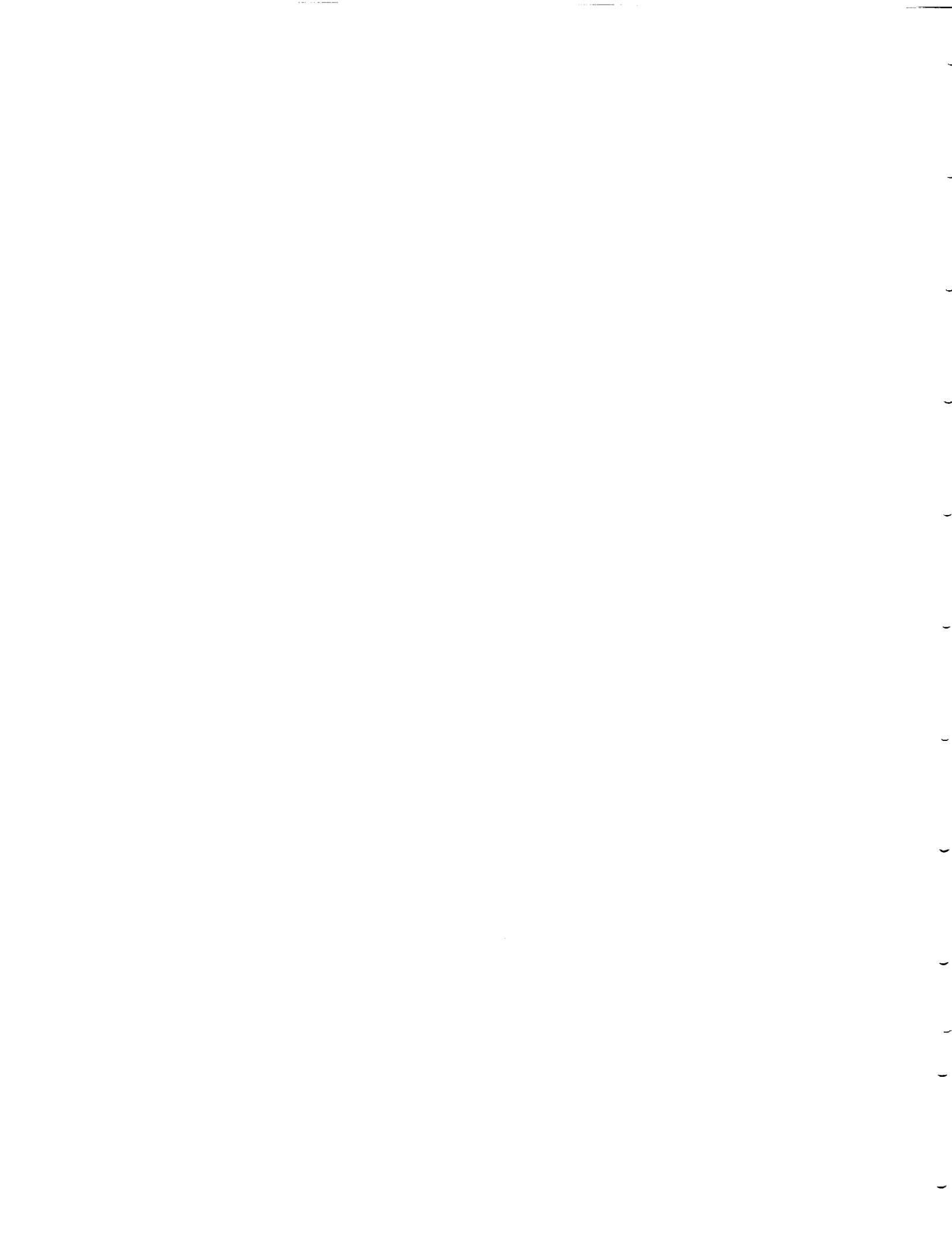



AVAILABLE DATA BASES: The National Park Service and the U.S. Fish and Wildlife service are the two sources of data needed.

- 1) Barrier Islands Maps
- 2) The GIS National Parks List
- 3) The National Park Index

#### Summary of Data Information

The Fish and Wildlife Service in addition to the National Park Service maintain and regulates designated islands. In general the data maintained by these two agencies incorporate all of the coastal barriers within the United States, but the data are not provided in digital format. The National Park Service, in contrast, has started a program of building digital data bases for islands within their jurisdiction. Limited funding is impacting the progress of this program.

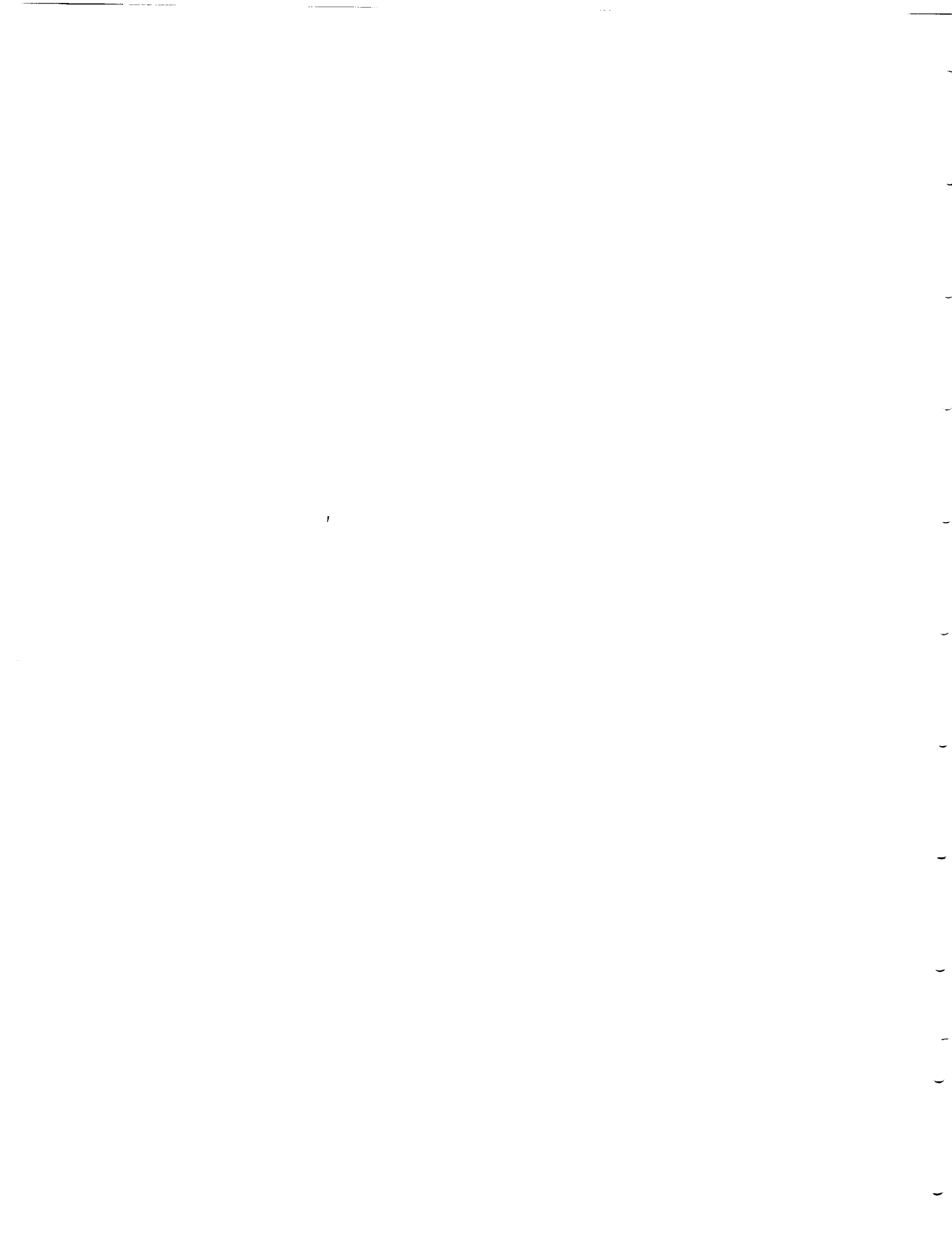

APPENDIX X: RECREATIONAL RIVER DATA BASES

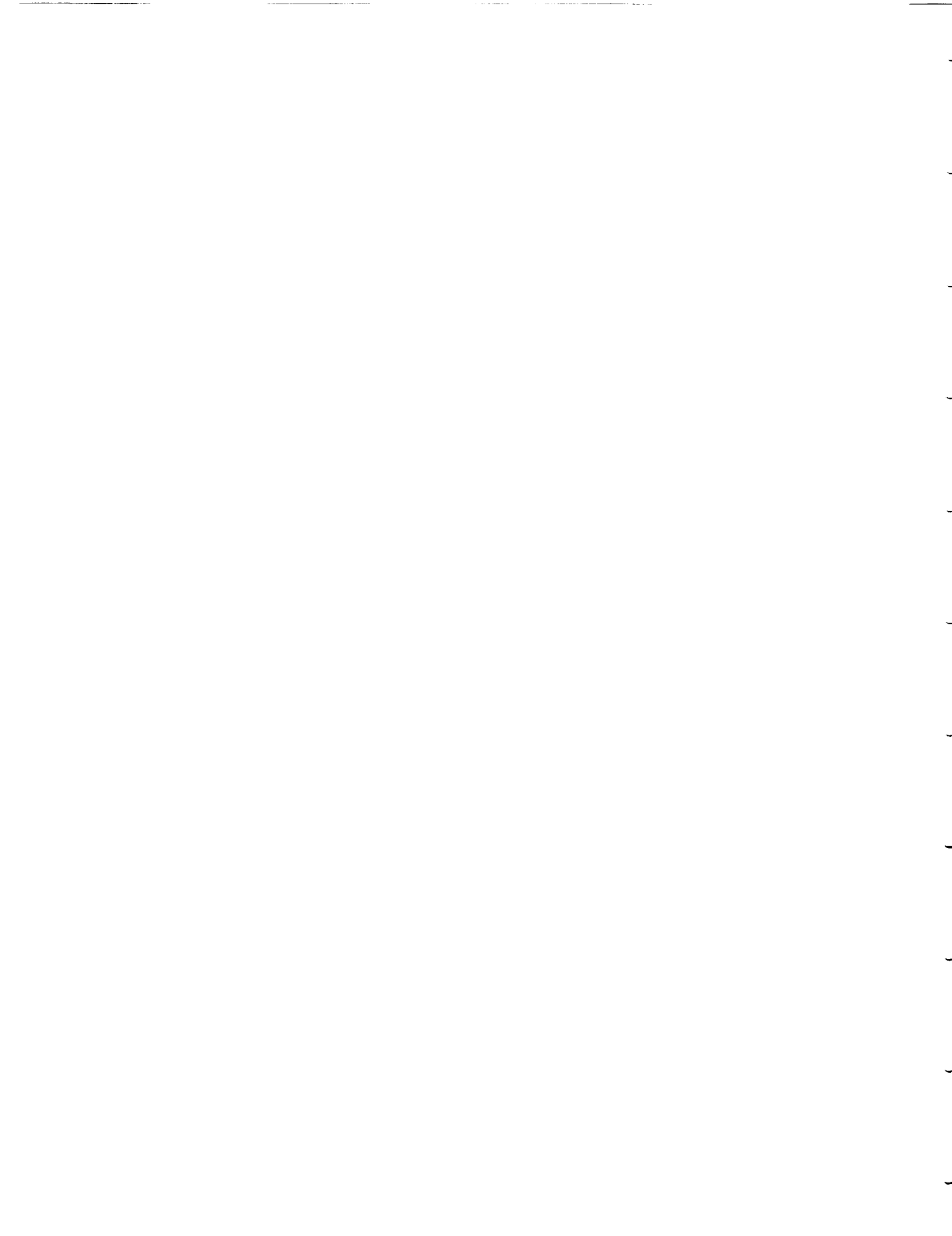

AVAILABLE DATA BASES: The National Park Service provides standard maps in the Wild and Scenic Rivers Inventory in addition to digital data.

- 1) The National Inventory of Wild and Scenic Rivers
- 2) The GIS national Parks List
- 3) The National Park Index
- 4) Digital Line Graph

### Summary of Information

Rivers in the National System are often referred to as wild and scenic rivers without regard to actual classification. The specific legal classification is an important distinction because it has direct effect on how the river is administered and whether certain activities on Federally owned land within the boundaries are permissible.

The available data bases contain geographic coordinates and could be implemented in a GIS system. The National Park Service has initiated such a program in the GIS Parks List. The Park Service has digitized 4 of the 122 designated rivers and is expected to finish all of the rivers within the next ten years. [9.14] Paper maps are available for identifying the location of the remaining 122 rivers. The Digital Line Graph, produced by the USGS, could be an interim data source for the identification of wild and scenic rivers.

In regard to aircraft routing, the studies being performed by the National Park Service in the Grand Canyon may have a substantial impact on aircraft routing and the protection of airspace over designated rivers. The results from these studies may require noise protection to all National Park lands and their users.

In addition to rivers afforded federal protection, approximately thirty states have chosen to identify additional river segments for protection. Moreover, many of these states have strengthened the regulations protecting the federally designated rivers. The data bases available from these states generally are geographically references.

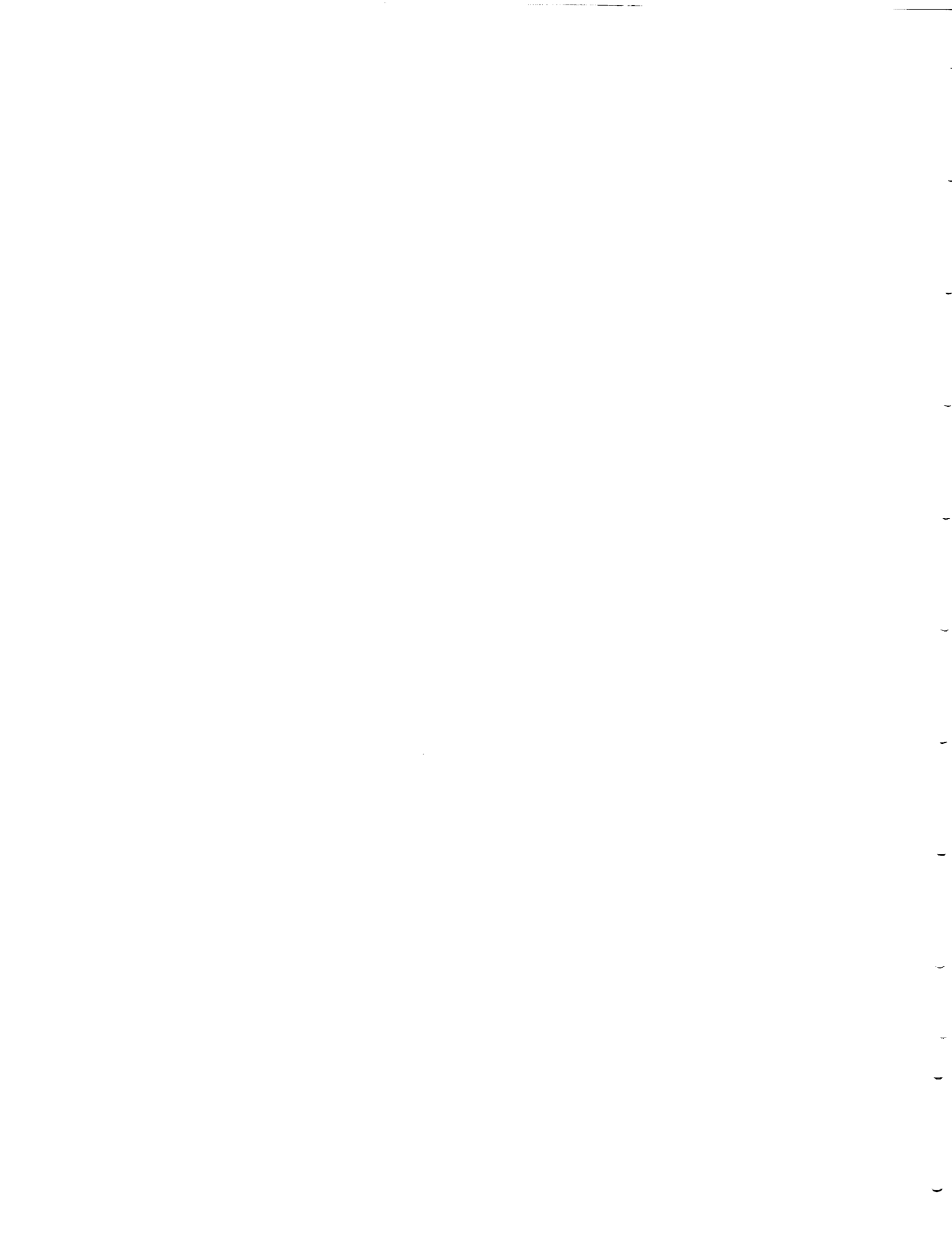

## LIST OF FIGURES

Figure 1.1:	Interrelationship of structure routing of aircraft tasks for developing a three-dimensional methodology . . . . .	6
Figure 2.1:	GIS elements . . . . .	8
Figure 2.2:	Typical GIS overlays . . . . .	9
Figure 2.3:	Example of noise overlay analysis . . . . .	10
Figure 2.4:	Typical airspace planning overlays . . . . .	11
Figure 2.5:	Raster and vector data structures . . . . .	11
Figure 2.6:	Average household income and aircraft noise contours: Dekalb County, Georgia . . . . .	14
Figure 2.7:	Computer generated three-dimensional airspace analysis program: Orlando International Airport . . . . .	15
Figure 2.8:	GIS vendors surveyed . . . . .	16
Figure 2.9:	Some common GIS capabilities . . . . .	17
Figure 2.10:	A possible three-dimensional GIS structure . . . . .	20
Figure 2.11:	A volumetric three-dimensional GIS data structure . . . . .	20
Figure 5.1:	Noise ordinance provision: nuisance . . . . .	47
Figure 5.2:	Noise ordinance provision: zoning/land use . . . . .	48
Figure 5.3:	Noise ordinance provision: vehicles . . . . .	49
Figure 5.4:	Noise ordinance provision: recreation vehicles . . . . .	50
Figure 5.5:	Noise ordinance provision: railroad . . . . .	51
Figure 5.6:	Noise ordinance provision: aircraft . . . . .	53
Figure 5.7:	Noise ordinance provision: construction . . . . .	54
Figure 5.8:	Noise ordinance provision: building code . . . . .	55
Figure 5.9:	Noise ordinance provision: animals . . . . .	56
Figure 5.10:	Noise ordinance provision: entertainment . . . . .	57
Figure 6.1:	U.S. regulated airspace . . . . .	64
Figure 6.2:	Airport radar service area (ARSA) . . . . .	66
Figure 6.3:	Three-dimensional property rights . . . . .	68
Figure 6.4:	An example of three-dimensional property ownership . . . . .	69
Figure 6.5:	Spatial relationship and operational control measures . . . . .	74
Figure 6.6:	Operational controls: general runway restrictions . . . . .	76
Figure 8.1:	Geographic hierarchy of census data . . . . .	103
Figure 8.2:	Integration of future land use (1990) with projected noise contours (1990), Dekalb County, Georgia . . . . .	107
Figure 8.3:	Flow chart showing file relations at a parcel based level . . . . .	108
Figure 8.4:	Flow chart for potential tiger/line file users . . . . .	110
Figure 9.1:	EIS procedure . . . . .	117
Figure 9.2:	Required information in an EIS . . . . .	119
Figure 9.3:	Research procedure . . . . .	121
Figure 9.4:	The basic steps of section 106 review . . . . .	126
Figure 9.5:	Bald eagle colony buffer requirements . . . . .	127

Figure 10.1:	Geosonics: Geographically distributed sound data . . . . .	135
Figure 10.2:	Atlanta vertiport: A three-dimensional approach simulation . .	137
Figure 10.3:	Atlanta: A three-dimensional approach simulation - Terminal en route system airspace . . . . .	138
Figure 10.4:	Atlanta vertiport: A three-dimensional approach simulation - Height obstacles . . . . .	139
Figure 10.5:	Atlanta vertiport: A three-dimensional approach simulation - Noise contours (DNL) . . . . .	140
Figure 10.6:	Aviation en route noise impact simulation . . . . .	148
Appendix:		
Figure D.1:	Digital Terrain Elevation Data (DTED) . . . . .	161
Figure E.1:	Digital planimetric data . . . . .	164
Figure E.2:	Organization of overlays and files for the digital line graphs (DLG's) . . . . .	166
Figure E.3:	Digital feature analysis data (DFAD) . . . . .	167
Figure E.4:	Interim terrain data (ITD) . . . . .	169
Figure G.1:	Automated air facilities information file (AAFIF) . . . . .	175
Figure M.1:	Obstruction standard anywhere . . . . .	205
Figure M.2:	Military airport imaginary surface . . . . .	209
Figure M.3:	Military airport imaginary surface . . . . .	210



## LIST OF TABLES

Table 2.1:	Interrelationship between geographic information systems and other sections . . . . .	12
Table 3.1:	Interrelationship of sound metrics and descriptors and other sections . . . . .	24
Table 4.1:	Interrelationship of land use data bases and other sections . . . . .	31
Table 5.1:	Municipal noise regulations . . . . .	42
Table 5.2:	Interrelationship between governmental regulatory data bases and other sections . . . . .	42
Table 5.3:	Municipal noise regulations . . . . .	45
Table 5.4:	Municipal noise laws by state . . . . .	59
Table 6.1:	Definition of controlled airspace . . . . .	65
Table 6.2:	Interrelationship between aircraft operational control measures and other sections . . . . .	70
Table 6.3:	Definitions of three-dimensional operational control measures . . . . .	71
Table 6.4:	Aircraft operational control measures . . . . .	79
Table 6.5:	Aircraft operational control measures: control strategy . . . . .	80
Table 6.6:	Aircraft operational control measures: spatial plane . . . . .	81
Table 6.7:	Aircraft operational control measures: location of control . . . . .	82
Table 6.8:	Aircraft operational control measures: spatial dimension . . . . .	83
Table 7.1:	Interrelationship of federal regulation and advisory circulars pertaining to route analysis and other sections. . . . .	85
Table 8.1:	Interrelationship between census and other sections. . . . .	101
Table 9.1:	Interrelationship between environmental attributes and other sections. . . . .	116
Table 10.1:	Aircraft routing operational parameters . . . . .	134

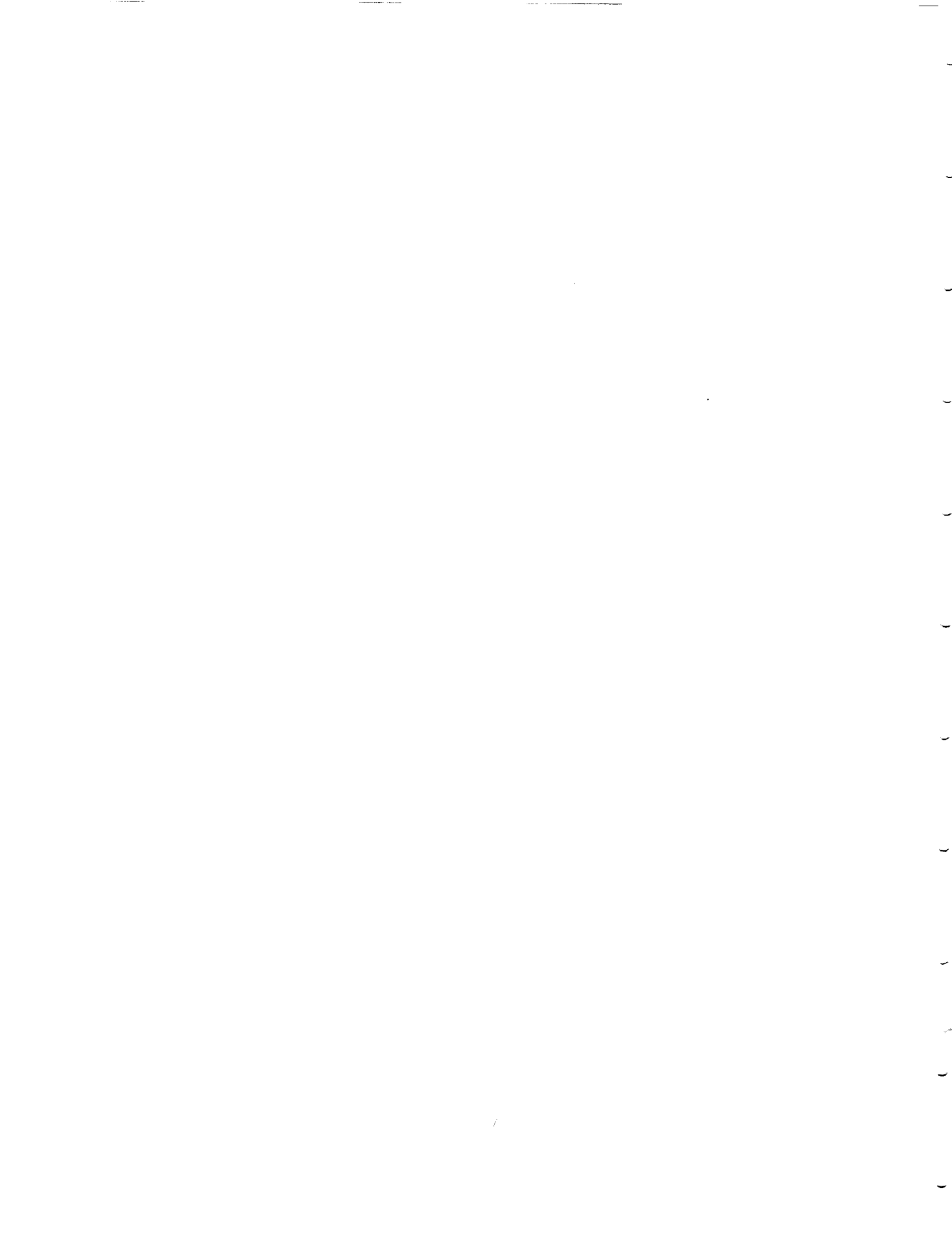

## LIST OF REFERENCES

- 2.1 American Institute of Planners, Airport Planning Workshop, Washington, D.C., 1979.
- 2.2 Bragdon, Clifford R., Dekalb County Atlanta Hartsfield International Airport Noise Study, February 1984.
- 2.3 City of Cleveland, Department of Port Control, Cleveland Hopkins International Airport FAR Part 150 Noise Exposure Map Project; Los Angeles International Airport, Department of Planning, FAR Part 150 Study.
- 2.4 Federal Aviation Administration, Integrated Noise Model (INM) Version 3.10, Washington, D.C., June 25, 1992.
- 2.5 Airspace Management System Users Manual; Department of Transportation, State of Florida, 1991.
- 2.6 Orlando International Airport, Computer Generated Three Dimensional Airspace Surface Analysis: FAR Part 77, FAA District Office, Orlando, Florida, 1993.
- 2.7 TIGER is a trademark of the United States Bureau of the Census for Topologically Integrated Geographic Encoding and Referencing.
- 2.8 Digital Line Graph (DLG) is a trademark of the U.S. Geological Survey of the United States Department of the Interior.
- 2.9 AutoCad and Digital Exchange Format (DXF) are trademarks of Autodesk, Inc.
- 3.1 Federal Interagency Committee On Noise, Federal Agency Review of Selected Airport Noise Analysis Issues, Washington, D.C., August 1992.
- 3.2 Wyle Laboratories, Air Force Procedure for Predicting Aircraft Noise Around Airbases: Noise Exposure Model (NOISEMAP) User's Manual, Aerospace Medical Research Laboratory, Wright Patterson Air Force Base (AAMRL-TR-90-011), February 1990.
- 3.3 Federal Aviation Administration, HNM Heliport Noise Model Version 1, User's Guide, DOT/FAA/EE 88-2, Washington, D.C., February 1988.
- 3.4 Bragdon, Clifford R., Noise Pollution: The Unquiet Crisis, Philadelphia: University of Pennsylvania Press, 1971.

- 3.5 Doolittle Aviation Commission, Airport Noise, Washington, D.C., U. S. Government Printing Office 1948.
- 3.6 Environmental Protection Agency, Office of Noise Abatement and Control, Information on Levels of Environmental Noise Requisite To Protect Public Health and Welfare With An Adequate Margin of Safety, EPA Report 550/9-74-004, Washington, D.C., 1974.
- 3.7 Federal Aviation Administration, Federal Aviation Regulations, Part 150 Airport Noise Compatibility Planning, Washington, D.C., January 18, 1985.
- 3.8 Bragdon, Clifford R., Airport Noise Compatibility Planning, Mike Monroney Center FAA Academy, Oklahoma City, February 1993.
- 4.1 Georgia Department of Community Affairs, Georgia Land Use Classification, Atlanta, December 1990.
- 4.2 Fredrick, Doyle G., Coordination of Surveying, Mapping, and Related Spatial Data Activities, Reston, VA, 1991.
- 4.3 Anon., SDTS: Setting the Standard, Geo Info Systems, July/August 1991.
- 5.1 Bragdon, Clifford R., Working Group VIII: State and Local Strategies, Combatting Noise in the '90s, American Speech and Hearing Association, December 1991.
- 5.2 Bragdon, Clifford R., Municipal Noise Legislation, Atlanta/New York: Fairmount Press, Van Norstrand Press, 1980.
- 5.3 Bragdon, Clifford R., The Status of Noise Control in the United States: State and Local Governments, Washington, D.C.: U.S. Government Printing Office, 1978.
- 5.4 Bragdon, Clifford R., Environmental Legislative Survey of Municipal Governments 1991-92, Atlanta: Georgia Institute of Technology, Office of the President, January 1992.
- 6.1 Federal Aviation Administration, Airman's Information Manual, November 14, 1991.
- 6.2 United States of America, Federal Aviation Act of 1958.
- 6.3 Federal Aviation Administration, Airman's Information Manual, November 14, 1991.
- 6.4 National Business Aircraft Association, Airport Noise Summary, 1991.

- 6.5 Bragdon, Clifford R., Environmental Survey of Municipal Governments, Georgia Institute of Technology, January 1992.
- 6.6 Federal Aviation Administration, Part 150 Airport Noise and Compatibility Planning Washington, D.C., January 18, 1985.
- 6.7 United States of America, Airport Noise and Capacity Act of 1990; Part 150 Airport Noise and Land Use Planning Program: Status, January 1993.
- 6.8 Federal Aviation Administration, Part 150 Airport Noise and Land Use Planning Program, Washington, D.C., January 1993.
- 7.1 Federal Aviation Administration, PART 36: Noise Standards: Aircraft type and Airworthiness certification (consolidated reprint comprising changes 1 through 10), Washington, D.C., June 1974, as amended.
- 7.2 Federal Aviation Administration, AC 150/5020-1 Noise Control and Compatibility Planning for Airports, Washington, D.C., August 1983. Washington, D.C. 20590.
- 7.3 Federal Aviation Administration, PART 150 - Airport Noise Compatibility Planning, Washington, D.C., June 1985.
- 7.4 Federal Aviation Administration, PART 77 - Objects Affecting Navigable Airspace, Washington, D.C., January 1975.
- 8.1 U.S. Department of Commerce, TIGER: The Coast-to-Coast Digital Map Data Base, Bureau of Census, 1991.
- 8.2 U.S. Department of Commerce, TIGER/LINE(TM) Census Files, 1990, Bureau of Census, 1991.
- 8.3 U.S. Department of Commerce, 1990 Census of Population and Housing: Tabulation and Publication Program, Bureau of the Census, July 1990.
- 8.4 U.S. Department of Commerce, 1990 Decennial Census Local Review Program Technical Guide, Bureau of Census, 1989.
- 8.5 U.S. Department of Commerce, Census Catalog & Guide 1991, Bureau of Census, June 1991.
- 8.6 U.S. Department of Commerce, County Business Patterns, Bureau of Census, August 1991.

- 8.7 U.S. Department of Housing and Urban Development, American Housing Survey for the United States, Bureau of Census, 1987.
- 8.8 McMillen, Daniel P. and McDonald, John F., Urban Land Value Functions with Endogenous Zoning, Journal of Urban Economics, Volume 29, Number 1, January 1991.
- 8.9 Gehring, Veronica and Little, Andy, A Multi-Participant, Public/Private County-Wide Addressing Project in Ada County, Idaho, 1990 URISA Proceeding, 1990, p.276-287.
- 8.10 Prosperi, David C. Assessment of And Agenda For Using Property Tax data in Urban and Regional Analysis, 1989 URISA Proceedings, Volume 4, 1989, p.115-128.
- 9.1 Public Law 100-91.
- 9.2 Federal Aviation Administration. Airport Environmental Handbook. October 8, 1985.
- 9.3 Advisory Council on Historic Preservation, Section 106, Step By Step. October. 1986.
- 9.4 U.S. Department of Interior, Bald Eagle Colony Buffer Requirement , Habitat Management Guideline for the Bald Eagle in the Southeast Region, Third Revision, January 1987.
- 9.5 Schaffer, Linda. Division Coordinator of the National Wetlands Inventory. 5 February 1992.
- 9.6 U.S. Department of Interior. The National Wild and Scenic Rivers Guide. December 1990.
- 9.7 Kautz, Randy S., Satellite Imagery and GIS Help Protect Wildlife Habitat in Florida, GIS World. May 1991. Volume 4 No.3.
- 10.1 Bragdon, Clifford R., Three-Dimensional Transportation Noise Planning, Transportation Research Board Summer Institute, Colorado Springs, Colorado, July 1992.
- 10.2 Bragdon, Clifford R., Strategic Three-Dimensional Transportation Planning, Intermodal Transportation Planning Conference Washington, D.C., July 1992.

- 10.3 National Research Council, Mapping Science Committee, Spatial Data Needs: The Future of the National Mapping Program, Washington, D.C., National Academy Press, 1990.
- 10.4 U.S. Geological Survey, Primary Mapping Economic Analysis: Phase I, 1987, Phase III, 1988.
- 10.5 Federal Interagency Coordinating Committee on Digital Cartography, Reports Working Group, Summary of GIS Activities in the Federal Government, Washington, D.C., 1988.

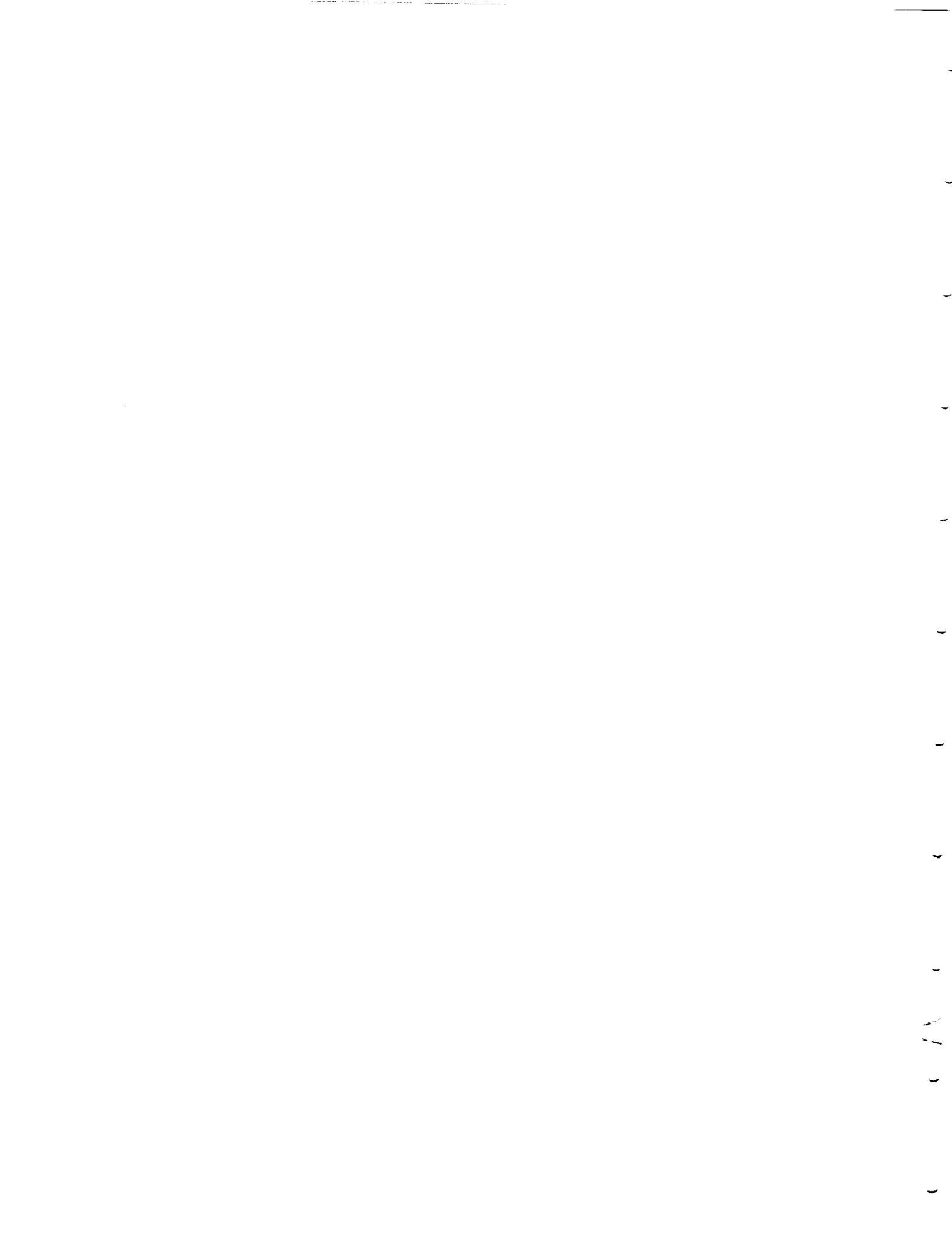



# REPORT DOCUMENTATION PAGE

Form Approved  
OMB No. 0704-0168

Public reporting burden for this collection of information is estimated to average 1 hour per response, including the time for reviewing instructions, searching existing data sources, gathering and maintaining the data needed, and completing and reviewing the collection of information. Send comments regarding this burden estimate or any other aspect of this collection of information, including suggestions for reducing this burden, to Washington Headquarters Services, Directorate for Information Operations and Reports, 1215 Jefferson Davis Highway, Suite 1204, Arlington, VA 22202-4302, and to the Office of Management and Budget, Paperwork Reduction Project (0704-0168) Washington, DC 20503.

1. AGENCY USE ONLY (Leave blank)	2. REPORT DATE <b>September, 1993</b>	3. REPORT TYPE AND DATES COVERED <b>Contractor Report 7/12/91 - 1/15/93</b>
----------------------------------	--	--

4. TITLE AND SUBTITLE <b>Strategic Planning for Aircraft Noise Route Impact Analysis: A Three Dimensional Approach</b>	5. FUNDING NUMBERS <b>C NAS1-19061 TA 9 WU 537-03-21-03</b>
---	--

6. AUTHOR(S) <b>C. R. Bragdon, M. J. Rowan, K. K. Ahuja</b>
--

7. PERFORMING ORGANIZATION NAME(S) AND ADDRESS(ES) <b>Georgia Institute of Technology Atlanta, Georgia 30332-0800</b>	8. PERFORMING ORGANIZATION REPORT NUMBER <b>A8612-009/1</b>
--	--

9. SPONSORING/MONITORING AGENCY NAME(S) AND ADDRESS(ES) <b>NASA Langley Research Center Hampton, Virginia 23681-0001</b>	10. SPONSORING/MONITORING AGENCY REPORT NUMBER <b>NASA CR-191484</b>
---	---

11. SUPPLEMENTARY NOTES  
**Final Report. Nasa Langley Project Manager: C. A. Powell**

12a. DISTRIBUTION AVAILABILITY STATEMENT <b>Unclassified - Unlimited Subject Category 71</b>	12b. DISTRIBUTION CODE
---	------------------------

13. ABSTRACT (Maximum 200 words)  
**The strategic routing of aircraft through navigable and controlled airspace to minimize adverse noise impact over sensitive areas is critical in the proper management and planning of the U.S. based airport system. A major objective of this phase of research is to identify, inventory, characterize and analyze the various environmental, land planning and regulatory data bases, along with potential three-dimensional software and hardware systems that can be potentially applied for an impact assessment of any existing or planned air route. There are eight data bases that have to be assembled and developed in order to develop three-dimensional aircraft route impact methodology. These data bases which cover geographical information systems, sound metrics, land use, airspace operational control measures, federal regulations and advisories, census and environmental attributes have been examined and aggregated. A three-dimensional format is necessary for planning, analyzing space and possible noise impact and their potential resolution. The need to develop this three-dimensional approach is essential due to the finite capacity of airspace for managing and planning a route system, including airport facilities. It appears that these data bases can be integrated effectively into a strategic aircraft noise routing system which should be developed as soon as possible, as part of a proactive plan applied to our FAA controlled navigable airspace for the United States.**

14. SUBJECT TERMS <b>Aircraft noise; aircraft noise prediction; aircraft operational controls; noise regulations; route analysis; sound metrics; geographical information systems; navigable airspace; land and space use planning; three-dimensional modeling.</b>	15. NUMBER OF PAGES <b>249</b>
	16. PRICE CODE

17. SECURITY CLASSIFICATION OF REPORT <b>Unclassified</b>	18. SECURITY CLASSIFICATION OF THIS PAGE <b>Unclassified</b>	19. SECURITY CLASSIFICATION OF ABSTRACT <b>Unclassified</b>	20. LIMITATION OF ABSTRACT
--	---	--	----------------------------

