

108
108 1

NASA Technical Memorandum 109027

**USER'S MANUAL FOR THE LANGLEY RESEARCH CENTER 14- BY 22-FOOT
SUBSONIC TUNNEL STATIC DATA ACQUISITION SYSTEM**

Nettie M. Orié and P. Frank Quinto

November 1993

(NASA-TM-109027) USER'S MANUAL FOR
THE LANGLEY RESEARCH CENTER 14- BY
22- FOOT SUBSONIC TUNNEL STATIC
DATA ACQUISITION SYSTEM (NASA)
108 p

N94-17639

Unclas

G3/02 0194109



National Aeronautics and
Space Administration
Langley Research Center
Hampton, Virginia 23681-0001

TABLE OF CONTENTS

1.0	INTRODUCTION.....	1
1.1	Responsibilities.....	1
1.1.1	Test Engineer.....	1
1.1.2	Shift Leaders And Test Technicians.....	1
1.1.3	Data Reduction Personnel.....	2
2.0	CHECKLISTS.....	3
2.1	System Calibration.....	3
2.1.1	Computer Checklist.....	3
2.2	Power Switches Check.....	5
3.0	GENERAL DESCRIPTION OF PERIPHERALS.....	6
3.1	Tape.....	6
3.2	Line Printer.....	6
3.3	Disk.....	7
4.0	BOOTING THE SYSTEM.....	8
4.1	MODCOMP System Terminal.....	8
4.2	Establishing Current Test In System.....	8
5.0	OPERATING ACQUISITION PROGRAM.....	10
5.1	System Calibration.....	12
5.2	OAP Setup Record Input.....	13
	Channel Definition Record (Type 1).....	14
	Data Display Record (Type 6).....	16
	Computed Data Limits Record (Type 7).....	18
	Comment Record (Type *).....	18
	End Inputs Record (Type \$\$).....	18
5.3	Real-Time Application.....	18
5.4	OAP Variables Status.....	19
6.0	SETUP FOR ELECTRONICALLY SCANNED PRESSURE (ESP) DATA.....	21
6.1	OAP ESP Status Menu.....	21
6.2	ESP Calibration.....	23
6.3	Cancellation of ESP Setup.....	24

7.0	SAMPLES OF TXXX ID CODES (MENU).....	25
	Option '0' WIND-OFF ZERO	26
	'1' TAKE TARES	27
	'2' WIND-ON DATA.....	28
	'3' DYNAMIC ZERO.....	30
	'4' unused	
	'5' BALANCE SPAN	31
	'6' CALIBRATION	32
	'7' RECALL ZEROS	33
	'8' unused	
	'9' RESULTS ON A RUN SUMMARY.....	34
	'10' MODIFY OPTIONS	35
	'11' CALCULATE TARES	43
	'12' MODIFICATION OF CHANNELS	44
	'13' MODIFICATION OF BALANCE PARAMETERS.....	49
	'14' MODIFY PRESSURE.....	52
	'15' 'PRINT SPOOL	52
	'16' DISMOUNT TAPE.....	52
	'17' MODIFY FMETER.....	52
	'18' unused	
	'19' unused	
	'20' LAIRD TELEMEDIA.....	52
	'21' ESP CALIBRATION.....	53
	'22' 'TACH. RANGE CONTROL.....	54
	'23' unused	
	'24' REAL-TIME PLOT.....	55
	'25' TUNNEL LEDS.....	58
	'26' DTALK.....	59
	'99' PLAYBACK TAPE.....	60
	'EX' EXIT	60
8.0	QCODE OPTION.....	61
9.0	SETTING MODEL HEIGHT.....	62
9.1	Height Setup Procedure for the Sting-Mounted Models.....	62
9.2	Height Setup Procedure for the Vertical Air Strut.....	64
9.3	Model Height and Attitude with the Roll Sting.....	65

10.0	STAND-ALONE PROGRAMS.....	66
10.1	LSQ.....	66
10.2	PLTFDA.....	70
10.3	PLTPD.....	74
10.4	TCLEAR.....	77
10.5	DBASE.....	77
10.6	DBASEP.....	79

Figures

1	Sample Of Calibration Plot.....	68
2	Plot Position Indexes.....	72

APPENDIX

A	Instructions and Sample Test Setup Sheets.....	81
B	Test Information Forms.....	91



**USER'S MANUAL
FOR THE
LANGLEY RESEARCH CENTER
14- by 22-FOOT SUBSONIC TUNNEL
DATA ACQUISITION SYSTEM**

1.0 INTRODUCTION

This documentation provides information to those who use the MODCOMP-9250 32-bit data acquisition system at the 14- by 22-Foot Subsonic Tunnel.

1.1 RESPONSIBILITIES

The responsibilities of the personnel involved in a wind tunnel test are indicated in sections 1.1.1 through 1.1.3.

1.1.1 Test Engineer

The test engineer is responsible for the following items:

- a. Providing information for instrumentation to facility coordinator. Samples of setup sheets to be completed are given in Appendix A.
- b. Submitting requests for additional computations or printouts, and discussing them with data reduction personnel during the pretest planning.
- c. Providing strip information if electronically scanned pressures (better known as ESPs) are used.
- d. Providing a test schedule for the tunnel entry.

1.1.2 Shift Leaders And Test Technicians

Shift leaders and test technicians are responsible for the following items:

- a. Working closely with the test engineer during test setup, and providing assistance to the engineer for channel hookup and calibrations.
- b. Providing any channel or constant changes to data reduction personnel during a test entry.
- c. Positioning the tape file correctly at the beginning of the first shift and ensuring that an end-of-file is placed on the tape file at the end of second shift.
- d. Keeping the data tape log sheet current for each new tape file and making it available to the data reduction group.

- e. Taking data as dictated by a test schedule provided by the test engineer when a test is running.
- g. Monitoring to ensure that all of the required tasks previously described are performed.

1.1.3 Data Reduction Personnel

Data reduction personnel are responsible for the following items:

- a. Assigning unique test numbers to each wind tunnel investigation and ensuring that the test engineer has appropriate setup sheets available.
- b. Coordinating all of the information necessary for computing data during tunnel entry with the test engineers, shift leaders, and technicians. This includes any additional programming, setup of the graphic displays in the control room, and the creation of a force data base and a pressure data base, if necessary.
- c. Setting up OAP environment input file with proper addresses, ranges, channels, ESP ports, parameter names, and real-time page displays.
- d. Creating input files containing balance decks, ESP strip information, or flowmeter information.
- e. Creating input files containing aerodynamic reference interactions such as transfers (x, y, z), wall corrections, jet-boundary corrections, and reference lengths and areas.
- f. Ensuring that every test engineer is notified about the existence and use of additional programs pertinent to a successful tunnel entry, i.e., plotting (PLTFDA, PLTPD), least squares curve fit (LSQ), run summaries from data bases (DBASE, DBASEP), etc. An explanation of these programs is included in this document.
- g. Correcting and transferring raw data from files on disk to magnetic tapes.
- h. Constantly monitoring available disk space to ensure the existence of adequate space to create new raw data files and data bases.

2.0 CHECKLISTS

Checklists for system calibration and power switches follow.

2.1 SYSTEM CALIBRATION

The Static Data Acquisition System (SDAS) components primarily responsible for acquiring data are the NEFF 620/600 Data Acquisition Unit (DAU) and the PSI 780B electronically scanned pressure (ESP) measurement system. The NEFF 620/600 is a high speed unit that records multi-point, low-level analog signals and is used to record both analog and digital data. There is a NEFF 300 signal conditioner which is a data acquisition subsystem that conditions the output of signal transducers to be compatible with analog measuring systems. It prepares the transducer output for amplification, digital code conversion, and recording or processing. The NEFF 300 also provides excitation for individual channels and resistance calibrations, better known as RCALs. For a more detailed description of this subsystem, see the Wyle hardware manual, document number HD63231-312RO-D8. The major components of the pressure data acquisition system are the Data Acquisition Control Unit (DACU), Pressure Calibrate Unit (PCU), and the sensor port modules connecting a maximum of 1024 pressure transducers. The 14- by 22-Foot Subsonic Tunnel has the capacity to use two DACUs, thus doubling the maximum number of pressures to 2048. Pressure data are transmitted to the Modcomp over an IEEE-488 data line as unaveraged data (counts).

Before data are acquired by the Operating Acquisition Program (OAP) system, all data acquisition units (DAU) connected to the system must be calibrated. The NEFF 620/600 is calibrated by a command from the OAP calibration menu. When the calibrate option is selected, the system will scan and calibrate all of the analog channels (0 thru 127) at each of the four gains and filter frequencies. If ESPs are being used, they must also be calibrated on command through the OAP menu. Calibration constants are stored on the calibration disk files after each calibration, and the user is given a written report of the calibration via the line printer. If desired, calibration constants from the previous calibration may be recalled from disk after a system reboot.

2.1.1 Computer Checklist

The technicians are responsible for the daily review of the computer checklist. It details items to check on the tape drives, the general computer system, and calibration of the NEFF 620/600. The calibration of the NEFF is done by activating

the OAP which is accomplished by executing a procedure file named "DAS". The operator sets up the test environment when "DAS,n" or "DAS n" (n=1,5) is executed from the OAP terminal. The value of n, which represents the file number on which all of the information for a particular test has been stored, is pre-determined by the data reduction group. After the calibration is complete (which takes about twelve minutes), the technician checks the calibration report for any channel abnormalities. If everything appears normal, then the technician proceeds to prepare for the acquisition of data. Below is the sequence that should be followed.

a. Establish VISION Program

1. Bring up VISION on 9-inch ISC by doing a ^A (Break), followed with the command VIS BIG.
2. Check to see if SETCM is in the system. If not present, establish it.

b. Calibrate NEFF 620/600

1. Bring in Operating Acquisition Program at OAP terminal (DAS n).
2. Select Option 2 which will activate the calibration menu. On day shift, the NEFF should be calibrated at the beginning of the shift. On night shift, it should be done at the beginning of the dinner break.

c. Establish T-task

1. The selection of Option 5 of the menu establishes both the T (batch) and PR (real-time) tasks.
2. Make sure that the TAPE option is on if raw data are to be recorded.
2. Once the current test number has been entered, the T-task will automatically position the tape file correctly.

d. End of Night Shift

1. Remove all listings from the line printer.
2. Exit the T-task.

2.2 POWER SWITCHES CHECK

The data system hardware has a power sequencer located in the MODACS cabinet. To power up the systems, press the CPU-A and then the CPU-B buttons. The power sequencer does not power up the CRTs. In the event the hardware does not power up, check the power switches in the following locations.

a. Line Printer

1. ON LINE button, on top of the line printer
2. ON/OFF power switch, on the back of the line printer
3. 6/8 LPI determines if lines are written 6 or 8 lines per inch.
(Light on - 8 lines; light off - 6 lines; default - 6 lines)

b. CPU

ON/OFF power switch, inside cabinet at the bottom

c. Tape Drive

ON/OFF power switches for controller and peripherals, in the bottom of the unit

d. MODACS

ON/OFF power switch inside bottom rear of cabinet

e. CRTs

1. GraphOns : ON/OFF power switches on the right rear of each monitor
2. Maintenance Consoles : ON/OFF power switches on the right side of each monitor
3. 9-inch ISCs : ON/OFF power switches on the left rear of each monitor
4. 14-inch ISCs : ON/OFF power switches on the right front of each monitor

f. ESP. DACU

ON/OFF power key, on front of DACU

g. DIB in NEFF 600 DAU cabinet (Power button, on unit)

h. NEFF DAU

ON/OFF power switch, on right hand side of unit

3.0 GENERAL DESCRIPTION OF PERIPHERALS

A general description of the tape drive, line printer, and disk drive follows:

3.1 TAPE

The tape drive is 9-track and is self-loading. Once the RESET pad is pressed, the door will open, allowing the tape to be placed on the drive. When the door is closed, the tape will automatically load. A series of LED read-outs will then be displayed at the tape drive.

- a. Put a label on the tape (Test No., etc.)
- b. Insert a "Write" ring in back of tape.
- c. Mount tape
- d. Check for following LED read-outs:
 1. *LOCATING*
 2. *LOCKING*
 3. *LOADING*
 4. These messages are followed by information on the reel ---the size, characteristics, and density
 5. *LD POINT*
- e. Set density at 1600
 1. Press RESET, *BOT* will be displayed.
 2. Press DENSITY pad until the desired density is reached.
 3. Then press LD/ONL.
- f. Dismount tape
 1. Press RESET, *BOT* will be displayed.
 2. Then press RWD/UNL.
- g. When tape is unloaded, the following LED messages will be displayed
 1. *To open door press RESET To load tape press LD/ONL*

3.2 LINE PRINTER

- a. The line printer should be in the ON LINE mode.
- b. If the line printer should be off-line , ON LINE light indicator will be blinking
 1. Press ON LINE
 2. If paper jam occurs, open the yoke by turning adjustment lever on the left side of the printer.

- c. If VF error , the VF LOADED light will be off
 - 1. Press CLEAR , then VF LOADED
 - 2. Press ON LINE
- d. To set the top of form, do the following:
 - 1. Take printer off -line and open the adjustment lever. Rotate paper until perforation is right at the top of the word "TOP" (first gray area).
 - 2. Close adjustment lever.
 - 3. Press CLEAR and PAPER ADV simultaneously. The paper should advance. If not, repeat process again.
 - 4. Put printer back on-line.

3.3 DISK

- a. Disks are located just beneath the tape drive of each system.
- b. There are two disks assigned to each system ---- one is dedicated to system software and the other to SDAS application software and data storage.
- c. If the disks are ready, the indicator light will be amber in color. If the disks have not been spun up or have experienced some sort of problem, the indicator lights will be green.
- d. If, for any reason, the disks need to be removed, do the following:
 - 1. Spin disks down by pressing ON/OFF button on drive.
 - 2. Once indicator light is constant green, open door of drive and remove disk packs by grasping handle on front of cannister and pulling.
- e. If, the disks need to be placed in the disk drive, do the following:
 - 1. Open door of disk drive and slide packs in.
 - 2. On maintenance console, ESC --- then key in HALT,MC
 - 3. At disk drive, spin disks up by pressing ON/OFF button.
 - 4. Once indicator light is amber, system ready for re-boot.

4.0 BOOTING THE SYSTEM

- a. Make sure all hardware equipment is powered up.
- b. Press RESET button in top of CPU cabinet.
- c. Firmware begins an automatic download.

4.1 MODCOMP SYSTEM TERMINAL

At the MODCOMP maintenance console, observe the following:

- a. After firmware automatically loaded, message "SATISFIED" appears on monitor.
- b. TIME/DATE automatically loaded.
- c. After "Netdown program completed" message, terminal will be in batch mode.
- d. From keyboard, key in RTPASS c/r. (This command makes all global assignments and must be done prior to executing any tasks)
- e. From keyboard --- (^A or the BREAK key) followed by /SETCM/E,,XLM
- f. If it is desired to pass rotor parameters form the Rotor Control System to the SDAS system, it will be necessary to establish the task, HPTALK. HPTALK controls the handshaking required for the Rotor Control System to communicate with the T-task. From the keyboard --- (^A or the BREAK key) followed by /HPTALK/E,,XLM

The SDAS system software must be initiated through the OAP software. The DAU is calibrated on command only. Errors occurring during this process are written to the maintenance console, the line printer and/or the NEFF front panel.

4.2 ESTABLISHING CURRENT TEST IN SYSTEM

- a. Using the GraphOn terminal in the control room labelled "#1" which is to the left of the 9-inch ISC display, perform the following steps:
 1. BREAK:
 2. Type RUN BAT; a "\$" appears on the screen.
 3. Type "DAS n" or "DAS,n" (n=1,5)
(OAP environment deck will be read in, establishing how the system will be configured.)
 4. Option 5 will activate TXXX and real-time application software.
See Section 6.3 of this manual for more detail.

5. Ensure that TAPE, DBASE, LIST are ON if data are to be written to tape file, data base, or line printer.

Example: TAPE 0 (tape is OFF).

TAPE 1 (tape is ON).

6. Key in EX to exit the facility's application software. Once this is done, the operator will be returned to the OAP environment.

7. This terminal shall, from this point on, be referred to as the OAP terminal.

b. GraphOn terminal to the right of the 9-inch ISC display is the auxiliary terminal. It is dedicated to executing all stand-alone tasks used for data manipulation and presentation. The statement format is EXE,*task*,XLM.

The tasks are:

1. DBASE - Program used to access force data (balance, support, tunnel, flowmeter, and aerodynamic parameters).

2. DBASEP - Program used to access pressure data acquired through the use of ESP modules.

3. PLTFDA - Program used to plot data stored on the forces database.

4. PLTPD - Program used to plot data stored on the pressure database.

5. LSQ - Program used to plot data stored on the forces database for the purpose of obtaining a least square curve fit.

6. TLIST - Program that reads files with data in SIF format (SIF - Standard Information Format) and lists number of records and key names.

5.0 Operating Acquisition Program

The OAP task allows the user to directly set up, control, and view various system parameters. The operator accesses the OAP software by executing the DAS procedure, followed by a setup file number. The 14- by 22-Foot Subsonic Tunnel does not use the Wyle Laboratory created OAP to acquire or store data. It does, however, use it to set up real-time data displays at the two ISC terminals in the control room, to establish limits and ranges for channels, to calibrate the DAU (NEFF 620/600), and to calibrate the ESPs. The main menu for OAP follows.

OAP MENU

CURRENTLY OAP IS : NOT TAKING DATA
RECORDING MEDIA : NONE
FILE NAME : NONE

OPTION	
1	START/STOP CONTINUOUS RECORDING
2	CALIBRATION MENU
3	INPUT OAP SETUP RECORD
4	READ SETUP FILE
5	ACTIVATE REAL-TIME APPLICATIONS MENU
6	STATUS OF OAP VARIABLES
7	LIST OAP CONFIGURATION PRINTOUT
8	DISK STATUS OF DATA STORAGE FILES
9	DELETE OAP
10	RESTART THE DAU
E	EXIT OAP MENU

ENTER OPTION NUMBER :

Menu selections are made by entering the option number. The following paragraphs give a brief description of each option. Detailed information and examples of certain options will be covered in the remaining sections of this manual.

- 1. **START/STOP CONTINUOUS RECORDING** option starts or stops the recording of OAP acquired test data to the tape and/or disk(Not used by 14- by 22-Foot Subsonic Tunnel).
- 2. **CALIBRATION MENU** option replaces the OAP main menu with the OAP calibration menu. From the calibration menu, one may initiate calibrations of the NEFF 620/600, the ESP system, or perform resistive calibrations of all RCAL defined channels.

- 3. **INPUT OAP SETUP RECORD** option enables OAP environment setup records to be entered by the operator from the OAP operator's terminal.
- 4. **READ SETUP FILE** option begins the processing of an OAP environment setup file that was generated previously.
- 5. **ACTIVATE REAL-TIME APPLICATIONS MENU** option clears the screen of the OAP main menu and transfers to the 14- by 22-Foot SDAS application software.
- 6. **STATUS OF OAP VARIABLES** option replaces the OAP main menu with the OAP status menu.
- 7. **LIST OAP CONFIGURATION PRINTOUT** option provides a listing of the OAP system environment configuration.
- 8. **DISK STATUS OF DATA STORAGE FILES** option replaces OAP main menu with the OAP test data disk menu (Not used by 14- by 22-Foot Subsonic Tunnel).
- 9. **DELETE OAP** option removes all OAP processing from the system and transfers control to MODCOMP operating system.
- 10. **RESTART THE DAU** option restarts the NEFF 620/600 DAU scanning process after it has stopped during system operation.
- E. **EXIT OAP MENU** option causes the OAP to continue processing, however control of the OAP terminal is given to MODCOMP operating system after the operator presses the BREAK key and, at the ">" prompt, keys in "A" c/r. To go back to the OAP main menu at the OAP terminal, the operator must press the BREAK key. If "32/OC/" is displayed, key in the command "/MENU/E,,ZLM" c/r. If ">" is displayed , key in "OAP" c/r.

5.1 SYSTEM CALIBRATION

Before data is acquired, all data acquisition units (DAU) connected to the system should be calibrated. All calibrations are under control of the OAP system and are initiated by the operator through a special OAP Calibration Menu. When option 2 of the OAP main menu is selected, the desire is to interact with the NEFF 620/600 or the ESPs in some way. The main menu is then replaced by the following:

CALIBRATION MENU
CURRENTLY :CALIBRATION IN PROGRESS
NEFF CAL TO TEST DATA FILE :ON

OPTION

- 1 NEFF CAL
- 2 SAVE NEFF CAL MEMORY
- 3 RESTORE NEFF CAL MEMORY
- 4 NEFF TO TEST DATA FILE (ON/OFF)
- 5 TERMINATE CAL
- 6 ESP 3 POINT CALIBRATION
- 7 ESP ZERO OFFSET CALIBRATION
- 8 RCAL CALIBRATION
- 9 TRANSDUCER EXCITATION VOLTAGE CHECKOUT
- 10 RETRIEVE ALL CALIBRATIONS
- E EXIT MENU

ENTER OPTION NUMBER :

Menu selections are made by entering the option number. The following paragraphs give a short description of each option.

- 1. **NEFF CAL** option initiates a NEFF 620/600 calibration. The DAU is commanded to begin an automatic, internal self-calibration for all channels defined in the setup file, using all gain and filter steps available on the NEFF. The zero and full-scale corrections are determined for each channel and stored in the NEFF internal memory and written to calibration disk files. These corrections are not written to the data tape or disk supported by the SDAS application software. The entire process takes about twelve to thirteen minutes. A report is written to the printer.
- 2. **SAVE NEFF CAL MEMORY** option saves the NEFF 620/600 calibration memory to the calibration disk file.
- 3. **RESTORE NEFF CAL MEMORY** option retrieves the calibration data previously stored on the calibration disk file and uses it to overlay the current contents of the NEFF 620/600 calibration memory.
- 4. **NEFF CAL TO TEST DATA FILE(ON/OFF)** option controls whether or not the NEFF 620/600 memory contents are written to disk or tape. (Not used)

- **5. TERMINATE CAL** option cancels the NEFF calibration currently in progress.
- **6. ESP 3 POINT CALIBRATION** option initiates a long ESP calibration. The DACU is commanded to begin an automatic, internal self-calibration for all ESP data channels defined in the setup file, using each of the three pressure gain ranges. Three pressures are applied to all ESP transducers. The offset, sensitivity, and non-linearity coefficients are determined for each transducer. These coefficients are written to a calibration disk file. The process takes about four minutes. A report is written to the printer.
- **7. ESP ZERO OFFSET CALIBRATION** option initiates a short ESP calibration. The DACU is commanded to begin an automatic, internal self-calibration for all ESP data channels defined in the setup file, using each of the three pressure gain ranges. The first pressure range (vacuum) is applied to all ESP transducers. The offset coefficient is determined for each transducer. This coefficient, along with the sensitivity and non-linearity coefficients from the previous long calibration, are written to a calibration disk file. The process takes about two and-a-half minutes. A report is written to the printer.
- **8. RCAL CALIBRATION** option commands the NEFF 300 to perform a resistive calibration of all RCAL defined channels. This process closes the facility relays to apply a load across the channels. An average is taken and written to the calibration disk file. A report is written to the printer.
- **9. TRANSDUCER EXCITATION VOLTAGE CHECKOUT** option commands the NEFF 300 to perform a line-loss transducer checkout. (Not used)
- **10. RETRIEVE ALL CALIBRATIONS** option causes the previous calibrations for the NEFF 620/600 and the ESP DACU to be retrieved from their respective calibration disk files. This information now becomes the current calibration data. A report is written to the printer.
- **E. EXIT MENU** option causes the OAP calibration menu to be replaced by the OAP main menu.

5.2 OAP SETUP RECORD INPUT

Members of the Data Reduction Group are solely responsible for establishing a unique setup records file for each tunnel entry. However, it sometimes becomes necessary to alter those records real-time while the test is in progress. OAP has provided a means of accomplishing this task by selecting option 3 of the main menu. When this option is chosen, the operator is prompted for an OAP environment record through the operator's console keyboard. Records are

accepted one at a time, with each record being terminated by pressing the RETURN key. Once all of the desired changes have been made, the entry of "\$\$" signals OAP that an end of information has been reached and the operator is returned to the OAP main menu. These changes remain in effect until the system is rebooted or OAP is deleted. If the changes need to be permanent, see the data reduction person who is in charge of the test. Six different record types make up the setup file and OAP expects them to have a specific format. In addition, there are comment and end records. These records combine to define the OAP data environment configuration setup.

TYPE 1	-	Channel Parameter
TYPE 3	-	Control Parameter
TYPE 4	-	ESP Parameter
TYPE 5	-	Digital Constant Specification
TYPE 6	-	CRT Display Specification
TYPE 7	-	Parameter Limit Specification
TYPE *	-	Setup Comments
TYPE \$\$	-	End Setup Indicator

Only setup record types 1 and \$\$ are imperative for OAP system operation. In the absence of any of the other records, default values will be used. OAP requires that the record type identification (1, 3, 4, 5, 6, 7, *, \$\$) always appear in column 1, followed by at least one blank space and the remaining data fields. Each data field in the record must be separated from another by one or more blank spaces. Each data field consists of an identifier keyword of which only the first 2 characters are necessary (except for type 4 records where three or more characters may be required). The next few paragraphs will address the various OAP record types --- their format and purpose.

OAP Record Type 1 - Channel Definitions Setup Record

Format: 1 CHNO,nn NAME,xxxxxxxxxxxx DELETE,aaaa, RNGE,nnnn
 ULIMIT,nnnnn LLIMIT,nnnnn LCE(n, n ,n, n) FILTER,n
 LUNITS,xxx DPOINT,n REFERENCE,nnnn RCAL,nn,mm

CHNO,nn

This entry is mandatory as the first field on all type 1 records. This entry causes channel nn (nn=0-127 for analog channels; 512-775 for digital channels; 2000-4047 for ESP ports) to be scanned for data by the OAP system. One record is required for each channel number.

***NOTE:** A NEFF analog channel is 1 less than its MODCOMP counterpart. Thus a change to MODCOMP channel 1, for example, must be entered as "1 CH,0 RNGE,160"

NAME,xxxxxxxxxxx

This entry causes the assignment of a name to the channel. The name may be up to 12 characters long (A-Z, 0-9, :, \$, ., and space). Default: No name assigned.

DELETE,aaaaa

This entry allows one to delete a previous data assignment for the channel (aaaaa=LIMIT or NAME).

RNGE,nnnn

This entry specifies the NEFF 620/600 full-scale millivolt (mv) gain range (nnnn= 5, 10, 20, 40, 80, 160, 320, 640, 1280, 2560, 5120, 10240) for the channel.

ULIMIT,nnnnn

This entry specifies an upper boundary limit for the channel. Default: No limit check is made.

LLIMIT,nnnnn

This entry specifies a lower boundary limit for the channel. Default: No limit check is made.

LCE(n,n,n,n)

This entry specifies four conversion coefficients to be associated with the channel and is not used by the 14- by 22-Foot Subsonic Tunnel at all.

FILTER,n

This entry specifies the filter frequency (n = 1, 10, 100, 1000 Hz) for the channel. Default: 1

LUNITS,xxxxxxxxx

This entry assigns a units name of up to 9 characters for the channel. Default: No unit name assigned.

DPOINT,n

This entry specifies the number of decimal places (n = 0-7) to be retained when displaying the channel's real data. Default: 7

REFERENCE,nnnn

This entry specifies the reference voltage for the channel. Default: 5 volts

RCAL,nn,mm

This entry specifies that the particular channel is resistive calibrated. "nn" is the expected value in millivolts and "mm" is the allowed tolerance in percent. Default: 10%

***NOTE:** The handling of record types 3, 4, and 5 is best left to the Data Reduction Group. If there is a need to change such things as scan rate, the length of data averaging period, information on a digital channel, or alter the ESP setup, see someone in that group.

OAP Record Type 6 - Data Display Setup Record (Type 6)

Format: 6 PAGE,aa LINE,nn ADDRESS,nn BACKGROUND,aa
 CHANNEL,nn DPOINT,n FORMAT,xx FOREGROUND,aa
 LABEL,"xxx" NAME,"xxx" PARAMETER,"xxx" UNIT,"xxx"

PAGE,aa

This keyword identifies the master page on the ISC display (aa = 1-24) to which specific parameters are assigned. Default: None

LINE,nn

This keyword identifies the line number (nn = 1-24) to which specific parameters are assigned. Lines 1-12 are on the left -hand side of the page and lines 13-24 are on the right. Line 13 is usually reserved for display of the current date, time, and page number.

ADDRESS,nn

This entry specifies the address of a computed value. To determine what that address should be, one must first get a copy of the database parameters. That list will show, to the left of each parameter name, a database index number. The indices are 1-300. The formula to determine the corresponding address is:

$$\text{Address} = n*2 - 1, \text{ where } n=\text{index number}$$

Default: None.

BACKGROUND,aa

This keyword allows the operator to request a specific background color wherein aa may be BLK (black), RED (red), GRN (green), YEL (yellow), BLU (blue), MAG (magenta), CYA (cyan), or WHT (white). Default: Blue.

CHANNEL,nn

This keyword allows the operator to request a specific raw data channel (nn). The application software for this facility supports 96 analog channels, 32 digital channels, and 2048 ESP ports via the MODCOMP. For all analog channels, the NEFF's corresponding channel number is one less (*i.e.* MODCOMP channels 1, 2, 3,, 96 correspond to NEFF channels 0, 1, 2,, 95). The ESPs, channel numbers begin at 2000 for module 1, port 1 of the first DACU and continue through channel 2047 for module 32, port 32 of the second DACU. Default: None.

DPOINT,n

This keyword allows the operator to specify the number of decimal places to be displayed in the data value. Default: 7

FORMAT,xxx

This keyword provides for the entry of a specific format for a data value. Acceptable values for xxx are I*2 (single precision integer), I*4(double precision integer), R*4 (single precision real), R*6 (double precision real), R*8 (triple precision real), and CHR (character data). Default: R*4

BACKGROUND,aa

This keyword allows the operator to request a specific foreground color wherein aa may be BLK (black), RED (red), GRN (green), YEL (yellow), BLU (blue), MAG (magenta), CYA (cyan), or WHT (white). Default: White

LABEL,"xxx"

This keyword provides for the entry of up to 21 characters (A-Z, 0-9, :, \$, .. and space). The label, xxx, must be enclosed in double quotes and is displayed centered on the line. This feature is invoked for the purpose of identifying a page of data. Default: None

NAME,"xxx"

This keyword provides for the entry of up to 12 characters (A-Z, 0-9, :, \$, .. and space) to identify a data value. The name,xxx, must be enclosed in double quotes. Default: "CHANNOnnn" for channel numbers or "PARAMETERnnn" for calculated data. Default: "PARAMETERnnn"

PARAMETER,"xxx"

This keyword provides for the entry of up to 12 characters (A-Z, 0-9, :, \$, .. and space) to identify a data value. The parameter, xxx, must be enclosed in double quotes and is used to assign a name to a computed value. Default: "PARAMETERnnn"

UNIT,"xxx"

This keyword allows the operator to enter up to 9 characters (A-Z, 0-9, :, \$, .. and space) to specify the units to be displayed for the data value. The units name must be enclosed in double quotes. Default: "COUNTS" for channels or blanks for calculated values.

NOTE: Specifying "PSI" or "PSF" for an ESP causes the value to be converted to the specified units.

OAP Record Type 7 - Computed Data Limits Setup Record

Format: 7 NAME"xxx" ADDRESS,nnn UNITS,"xxx", ULIM,nnn
 LLIM,nnn FORMAT, xxx DPOINT,n

or

 7 PARAMETER"xxx" UNITS,"xxx", ULIM,nnn LLIM,nnn
 FORMAT, xxx DPOINT,n

One of the following entries must be present before any of the other setup entries are made ---- NAME"xxxxxxx" ADDRESS,nnn or PARAMETER"xxxxxxx". ULIM and LLIM specify the upper and lower boundary limits to be checked. Defaults: Maximum positive R*4 value and maximum negative R*4 value respectively. An explanation of the other keywords may be found in a discussion of the TYPE 6 record setup.

OAP Record Type * - Comment Setup Record

OAP provides the comment record as a means of annotating the other setup records. This record may appear anyplace in the setup file and must begin with an asterisk in column 1 followed by a space and then the comment.

OAP Record Type \$\$ - End Inputs Setup Record

OAP provides the end inputs record as a means of signaling the end-of-information on the OAP setup file or input from the keyboard. The format is "\$\$" in columns 1 and 2.

5.3 REAL-TIME APPLICATION

The selection of option 5 of the OAP main menu causes the 14- by 22-Foot application software to gain control of data handling. The operator will be prompted to specify the test number by the message, "Enter test number". After the test number is entered, one of two things will happen. If a test other than the one keyed in resides in the system, the operator will be prompted with the following message:

Current test is xxx (where xxx is the other test number)

Enter test side to replace (1)

At this point, the operator needs to respond by keying in the number "1" in order to de-establish the previous test and establish the new one. The data acquisition system limits the number of active tests to just one. Go to section 8.0 for further instructions and information on the TXXX task.

5.4 OAP VARIABLES' STATUS

When option 6 of the OAP main menu is selected, the main menu is replaced with the OAP STATUS MENU page. This menu displays the current status of several pieces of hardware on the system and is of the following format.

OAP STATUS MENU

1	ID	0
2	LIST STATUS	ON
3	HOLD STATUS	OFF
4	CONTINUOUS TEST POINT	ON
5	AVERAGE PERIOD	ON 2 SECS/PERIOD
6	FORMAT	BOTH
7	POINT NUMBER	1
8	MAGTAPE STATUS	OFF MT1
9	WEOF TO MAGTAPE	
10	DISK STATUS	OFF
11	ESP DACU 1 STATUS	ON (64) PRESSURES
12	ESP DACU 2 STATUS	OFF (0) PRESSURES
13	ESP SCAN RATE	10 FRAMES/SEC
14	NEFF 600 SCAN RATE	50 FRAMES/SEC
E	EXIT MENU	

HIT RETURN KEY FOR ESP STATUS PAGES

ENTER STATUS REQUEST:

Options 2-4, 8, and 10-12 are toggle options. The selection of any one of these causes the opposite condition to be set (*i.e.* ON becomes OFF and OFF becomes ON). Option 5 will also display a message to the operator, "INSERT NEW AVERAGE PERIOD". If an averaging period of 0 is entered, averaging is set to OFF and no averaging is done until a value of 1-99 is entered to turn averaging ON. In addition to option 5, only options 11-14 should be of concern to users in the 14- by 22-Foot Subsonic Tunnel.

11. **ESP DACU 1 STATUS** - This option turns ON/OFF the ESP DACU 1. If the DACU 1 is set to ON the number of ESP ports that have been assigned to the first unit are displayed.

12. **ESP DACU 2 STATUS** - This option turns ON/OFF the ESP DACU 2. If the DACU 2 is set to ON the number of ESP ports that have been assigned to the second unit are displayed.

13. **ESP SCAN RATE** - The selection of option 13 prompts the operator with the message, "SCAN RATE IN FRAMES PER SECOND", to enter the number of data frames per second that the DACU is to be scanned by the OAP system. This rate is usually set at 10 frames per second.

14. **NEFF 600 SCAN RATE** - The selection of option 14 prompts the operator with the message, "INSERT SCAN RATE IN FRAMES PER SECOND", to enter the number of the NEFF 620/600 scan rate wanted. This rate is usually set at 50 frames per second. The default scan rate is 30 frames per second.

EX - When this option is selected, the operator's console will once again display the OAP main menu.

6.0 SETUP FOR ELECTRONICALLY SCANNED PRESSURE (ESP) DATA

After all modules and pressure tubing are connected, turn on the ESP Data Acquisition and Control Unit (DACU) which is located in the computer room, just to the right of the A-side NEFF 620/600 DAU. Press the **RESET** button. From the OAP terminal, bring up the OAP menu (see Section 4.2) and select the Status option, option 6 (see Section 6.0).

6.1 OAP ESP STATUS MENU

Option 6 will allow the console operator to view values that have been assigned to control the data acquisition. This includes the display of the ESP STATUS MENU page. Options are selected by number and contain information about whether a particular DACU is being used, number of pressures, and the corresponding digiquartz constants. The ESP status menu page follows.

ESP1 STATUS MENU

1 SYSTEM (ON)	64 PRESSURES	2 ESP CALIBRATION DELAY	40 SECS.	
3 REF TRAN 1 PRESS.	64	10 REF TRAN 2 PRESS	0	17 REF TRAN 3 PRESS 0
4 ZERO = -.8380.33335	11	ZERO = 0.00000000	18	ZERO = 0.00000000
5 SPAN = .721.14844	12	SPAN = 0.00000000	19	SPAN = 0.00000000
6 NONL 2=-20.646410	13	NONL 2= 0.00000000	20	NONL 2=0.00000000
7 NONL 3=0.20974760	14	NONL 3= 0.00000000	21	NONL 3=0.00000000
8 DATE 071990	15	DATE NODATE	22	DATE NODATE
9 SERIAL # 7777	16	SERIAL # NOSERIAL	23	SERIAL # NOSERIAL
24 REF TRAN 4 PRESS.	0	31 REF TRAN 5 PRESS	0	38 REF TRAN 6 PRESS 0
25 ZERO = 0.00000000	32	ZERO = 0.00000000	39	ZERO = 0.00000000
26 SPAN = 0.00000000	33	SPAN = 0.00000000	40	SPAN = 0.00000000
27 NONL 2=0.00000000	34	NONL 2= 0.00000000	41	NONL 2=0.00000000
28 NONL 3=0.00000000	35	NONL 3= 0.00000000	42	NONL 3=0.00000000
29 DATE NODATE	36	DATE NODATE	43	DATE NODATE
9 SERIAL # NOSERIAL	37	SERIAL # NOSERIAL	44	SERIAL # NOSERIAL

ENTER REQUEST (<CR> = NEXT PAGE) (<E> = EXIT MENU) :

If <CR> is done, the status menu for the second DACU will be displayed. The next few paragraphs will supply more detail about the various options and fields that may be entered from the operator's console.

1. **SYSTEM** - This option turns ON/OFF the ESP DACU 1. Selection of this option acts as a toggle. If the DACU 1 is set to ON, the OAP system will be able to scan the first DACU and will display the number of ESP ports that have been assigned to it. If it is set to OFF, the OAP system will not recognize the first DACU,
2. **ESP CALIBRATION DELAY** - This option prompts the operator to enter the number of seconds for pressure settling delay between ESP DACU calibration range switching. Valid entries are from 1 to 255 seconds.
3. **REF TRAN PRESS** - The selection of this option prompts the operator to enter the number of pressure ports connected to the first reference transducer standard or digiquartz. The maximum number of pressure ports that may be connected to an ESP DACU is 1024. The number of ports assigned to this particular digiquartz will be displayed also.
4. **ZERO** - The selection of this option prompts the operator to enter the zero calibration coefficient for the first digiquartz.
5. **SPAN** - The selection of this option prompts the operator to enter the span calibration coefficient for the first digiquartz.
6. **NONL2** - The selection of this option prompts the operator to enter the first non-linearity calibration coefficient for the first digiquartz.
7. **NONL3** - The selection of this option prompts the operator to enter the second non-linearity calibration coefficient for the first digiquartz.
8. **DATE** - The selection of this option prompts the operator to enter the calibration date (maximum of 8 characters) for the first digiquartz.
9. **SERIAL #** - The selection of this option prompts the operator to enter the serial number (maximum of 8 characters) for the first digiquartz.
- 10 to 16. - The prompts from these options compare directly to options 3-9, however they address the second digiquartz only.
- 17 to 23. - The prompts from these options compare directly to options 3-9, however they address the third digiquartz only.
- 24 to 30. - The prompts from these options compare directly to options 3-9, however they address the fourth digiquartz only.
- 31 to 37. - The prompts from these options compare directly to options 3-9, however they address the fifth digiquartz only.
- 38 to 44. - The prompts from these options compare directly to options 3-9, however they address the sixth digiquartz only.

6.2 ESP CALIBRATION

- a. Once the setup for the ESPs has been determined to be correct, the desire would be to calibrate the pressures. This is accomplished by selecting option 2 from the main OAP menu.
- b. From the Calibration Menu, select option 6 (if a long calibration is desired) or option 7 (if a short calibration) is desired. See Section 6.1 for more details on the differences in the two.

***NOTE:** A long cal. must have been done before any short cal. can be requested.

- c. The OAP console operator will be prompted to indicate whether the desire is to calibrate ESP 1, 2, or both or take no action and exit at this point, thus returning to the main OAP menu.
- d. The operator should then activate the real-time application software by selecting option 5 of the main OAP menu.
- e. Once the batch and real-time tasks have been established, select an ID code of 10 from the TXXX menu. Modify the parameter IESP to correspond to the correct DACU. An example follows.

```
TEST  273      RUN      35      LAST POINT  8 ID      12
```

```
ENTER ?? FOR MENU OR NEW DATA ID
10
```

```
TEST  273      RUN      31      POINT  9      ID      10
QCODE 1      MCODE  0      NBAL  1      SAMPLES 50
WCODE 0      CONF   0      TAPE  0      DBASE   1
PCODE 0      LIST   1      MPORT 0     IPORT  0
IESP  0      SCODE  1      DEBUG 1      FMCODE  3
RLENGTH232  VLENGTH 0
```

```
ENTER NAME OF PARAMETER TO CHANGE OR CR FOR NONE
```

```
IESP
```

```
ESP DATA?? 0 = NONE, 1 = ESP 1, 2 = ESP 2, 3 = BOTH (0)
ENTER ANY CHANGE
```

```
1
TEST  273      RUN      31      POINT  9      ID      10
QCODE 1      MCODE  0      NBAL  1      SAMPLES 50
WCODE 0      CONF   0      TAPE  0      DBASE   1
PCODE 0      LIST   1      MPORT 0     IPORT  0
IESP  1      SCODE  1      DEBUG 1      FMCODE  3
RLENGTH232  VLENGTH 0
```

```
ENTER NAME OF PARAMETER TO CHANGE OR CR FOR NONE
```

```
TEST  273      RUN      35      LAST POINT  9      ID      10
```

ENTER ?? FOR MENU OR NEW DATA ID

- f. The selection of an ID code of 14 allows the pressures to be modified. It is here that strip information and the conversion of ESPs to PSF may be accomplished.

Respond to the following statements:

1. Do you want to input the strips? (Y/N)

***NOTE:** The strips are read in by the engineer or by data reduction personnel.

2. Enter pressure units factors for ESP

144.0

***NOTE:** The application software measures the ESPs in PSI but allows them to be converted to PSF. If PSF is desired, the pressure units scale factor is 144. Otherwise, it remains a 1. The 144 is mandatory if the engineer wishes to compute absolute pressures or pressure coefficients.

- g. Once the ESPs have been turned on in the TXXX task and the strips have been read in, only steps a-c need be followed for future calibrations.

6.3 CANCELLATION OF ESP SETUP

a. Once ESPs have been activated through OAP, the test conductor may opt to not record pressures through the 14- by 22-Foot facility's application software. To accomplish this, enter the test program; select option 10; and disable IESP (i.e., set to 0); in a manner similar to the procedure given in 7.2e. While IESP is disabled, the TXXX task will function as if there were no pressures in the system.

b. The pressure data will still be available through the OAP task. To eliminate the pressures completely, the operator must interact with the OAP main menu and select option 6. Options 11 or 12 of the OAP Status menu will turn ESP off or ESP communications may be turned OFF using option 1 from the ESP menu in OAP.

7.0 SAMPLES OF TXXX ID CODES (MENU)

The menu of TXXX ID codes is given below, and more complete descriptive examples are given in this section. This menu is the main driver for the 14- by 22-Foot Subsonic Tunnel application software. The menu is displayed by entering '??' in response to the following prompt.

ENTER ?? FOR MENU OR NEW DATA ID

MENU for TXXX Samples Of ID Codes

??

ID CODES

0 - WIND-OFF ZERO

2 - WIND-ON DATA

4 -

6 - CALIBRATION

8 -

10 - MODIFY OPTIONS

12 - MODIFY CHANNELS

14 - MODIFY PRESS.

16 - DISMOUNT TAPE

18 -

20 - LAIRD TELEMEDIA

22 - TACH. RANGE CONTROL

24 - REAL-TIME PLOT

26 - DTALK

99 - PLAYBACK TAPE

1 - TAKE TARES

3 - DYNAMIC ZERO

5 - BAL. SPAN

7 - RECALL ZEROS

9 - RUN SUMMARY

11 - CALC. TARES

13 - MODIFY BALANCE

15 - PRINT SPOOL

17 - MODIFY FMETER

19 -

21 - ESP CALIBRATION

23 -

25 - TUNNEL DISPLAYS

EX - EXIT

TEST 361 RUN 3 LAST POINT 0 ID 24

ENTER ?? FOR MENU OR NEW DATA ID

WIND-OFF ZERO
(Identifier 0)

ENTER ?? FOR MENU OR NEW DATA ID

0

Waiting for data

Data received

***** 1/07/83 13:45:50 *****

ZEROS FOR RUN 136 POINT 12

TA	= 0.0000	(0.0000)	TDEW	= 0.0000	(0.0000)
A1	= 0.14876E-01	(0.12345E-01)	B1	= -0.12453E-01	(-0.13587E-01)
THETAC	= 0.14876E-01	(0.12345E-01)	SA1	= -0.12453E-01	(-0.13587E-01)
SB1	= 0.14876E-01	(0.12345E-01)	FLAP	= -0.12453E-01	(-0.13587E-01)
FEATHER	= 0.14876E-01	(0.12345E-01)	NSIK2.5	= 0.16451E-02	(0.16234E-02)
ASIK2.5	= 0.15176E-01	(0.15235E-01)	PSIK2.5	= 0.10921E-02	(0.10834E-02)
RSIK2.5	= 0.21566E-01	(0.2011E-01)	YSIK2.5	= 0.20051E-02	(0.19234E-02)
SSIK2.5	= 0.12876E-01	(0.12345E-01)	VSIK2.5	= 0.0000	(0.0000)
N748	= 0.14876E-01	(0.15045E-01)	A748	= 0.19451E-02	(0.19234E-02)
P748	= 0.10916E-01	(0.11145E-01)	R748	= 0.22222E-02	(0.22134E-02)
Y748	= 0.14867E-01	(0.14888E-01)	S748	= 0.11215E-02	(0.11234E-02)
V748	= 0.0000	(0.0000)	PITCH	= 0.0000	(0.0000)
ROLL	= 0.0000	(0.0000)	GPITCH	= 0.0000	(0.0000)
GROLL	= 0.0000	(0.0000)	V32	= 0.0000	(0.0000)
PA	= 0.0000	(0.0000)	QI	= 0.0000	(0.0000)
PTOT	= 0.0000	(0.0000)	JT1	= 0.0000	(0.0000)
JT2	= 0.0000	(0.0000)	JT3	= 0.0000	(0.0000)
ELEV	= 0.0000	(0.0000)	PITCHM	= 0.0000	(0.0000)
RPMMR	= 0.0000	(0.0000)			
THETAZ	= 0.13		PHIZ	= 0.00	

VOLTAGES ZEROS FOR RUN 136 POINT 12

1	TA	= 0.52337	2	TDEW	= 0.53782
3	A1	= 0.14876E-01	4	B1	= -0.12543E-01
4	THETAC	= 0.14876E-01	5	SA1	= 0.12453E-01
6	SB1	= 0.14876E-01	7	FLAP	= 0.12453E-01
8	FEATHER	= 0.14876E-01	10	NSIK2.5	= 0.16451E-02
11	ASIK2.5	= 0.15176E-01	12	PSIK2.5	= 0.10921E-02
13	RSIK2.5	= 0.21566E-01	14	YSIK2.5	= 0.20051E-02
15	SSIK2.5	= 0.12876E-01	16	VSIK2.5	= 5.0024
17	N748	= 0.14876E-01	18	A748	= 0.19451E-02
19	P748	= 0.10916E-01	20	R748	= 0.22222E-02
21	Y748	= 0.14867E-01	22	S748	= 0.11215E-02
23	V748	= 4.9997	24	PITCH	= 0.23761E-02
25	ROLL	= 0.62134E-03	26	GPITCH	= 0.98342E-03
27	GROLL	= 0.99211E-03	32	V32	= 5.0012
97	PA	= 30065.	98	QI	= 0.0000
99	PTOT	= 30059.	100	JT1	= 0.0000
101	JT2	= 0.0000	102	JT3	= 0.0000
109	ELEV	= 87306.	110	PITCHM	= 63108.
111	RPMMR	= 0.0000			

TAKE TARES
(Identifier 1)

ENTER ?? FOR MENU OR NEW DATA ID

1

Waiting for data

Data complete

-5.37	0.00					
2.985	-85.98	-247.0	0.7469	0.3532	1.074	

TEST 273 RUN 35 LAST POINT 7 ID 1

ENTER ?? FOR MENU OR NEW DATA ID

The first row of numbers represent the values of the pitch and roll angles respectively. The second row of numbers are the values for the balance forces and moments (normal, axial, pitching moment, rolling moment, yawing moment, and side). This information is output for each pitch angle taken. At least 10 points are needed (10 pitch angles) and no point should be taken at $\alpha = 0^\circ$. After the last point, take a wind-off zero (ID = 0) and weight tares will be calculated and the results displayed on the monitor and the line printer. An example of that output follows.

TARES FOR BALANCE		1629S AFTER 16 PASSES			7/29/92	9:48:57	
WT(SIN)	WT(COS)	XBAR	YBAR	ZBAR	PHIO	THETA0	
921.3	921.6	8.439	0.6612E-01	2.465	0.1116E-01	-0.5000E-01	
-5.37	0.00	2.985	-85.98	-247.0	0.7469	0.3532	1.074
		-0.1083	0.1643	0.2698	1.517	-5.501	0.6271
-2.01	0.00	0.3860	-32.15	-85.80	0.8384E-01	0.6551E-01	0.3398
		0.1482	0.1090	-1.202	0.4062	-2.114	0.2161
1.99	0.00	1.029	32.02	74.04	-0.4141	0.3402	-0.2788
		0.2015	-0.1855E-01	-0.6448	-0.8485	2.511	-0.2412
4.01	0.00	2.067	64.30	142.6	-2.942	0.3924E-01	-0.4680
		-0.7109	-0.649E-01	2.062	-3.722	4.478	-0.3938
8.01	0.00	9.994	128.3	241.0	-3.231	-1.243	-0.5545
		0.1385	-0.7526E-01	-0.7993	-4.656	7.463	-0.7502
10.02	0.00	15.59	160.4	277.3	-5.117	-3.506	-0.1763
		0.4997	0.4517E-02	-0.2994	-6.461	7.384	-0.5998
12.00	0.00	20.71	191.6	304.1	-5.490	-5.874	-0.3111
		-0.5004	-0.2539E-01	1.087	-7.091	7.079	-0.9424

TEST 273 RUN 35 LAST POINT 14 ID 1
ENTER ?? FOR MENU OR NEW DATA ID

In the tare report, the first line gives the calculated result of the weight of the model using sine, the weight of the model using cosine, XBAR, YBAR, ZBAR, PHIO, and THETA0.

Identifier 1 - Continued

This is followed by a pair of lines for each pitch angle that was taken during the tare run. The first line contains the values for the pitch and roll angles, the normal, axial, pitching moment, rolling moment, yawing moment, and side. The second line in the pair contains the calculated results after removing the deltas (attitude corrections) from each balance component.

In the example below, there was no balance; no tares could be taken.

```
TEST 273      RUN      35      LAST POINT  8 ID      1
ENTER ?? FOR MENU OR NEW DATA ID
1
```

NO BALANCE _ WHY ARE YOU TAKING TARES?

```
TEST 273      RUN      35      LAST POINT  9 ID      1
ENTER ?? FOR MENU OR NEW DATA ID
1
```

***NOTE:** It is suggested that a SAMPLE rate of 50 or 100 be used during the taking of tares.

WIND-ON DATA
(Identifier 2)

ENTER ?? FOR MENU OR NEW DATA ID

2

Waiting for data
Data complete

```

*****
*      8/13/82      14:34:45      *****
TEST      = 275.00   RUN           = 1.0000   POINT      = 8.0000
ID         = 2.0000   OCODE          = 0.0000   MCODE     = 0.0000
NBAL       = 1.0000   SAMPLES        = 30.0000  WCODE     = 0.0000
CONF       = 0.0000   TAPE           = 0.0000   DBASE     = 1.0000
PCODE      = .0.0000  LIST           = 1.0000   MPORT     = 0.0000
IPORT      = 0.0000   IESP          = 0.0000   SCODE     = 1.0000
DEBUG      = 1.0000   FMCODE        = 0.0000   RLENGTH  = 266.00
VLENGTH    = 0.0000   YRMODA        = .8028.0  HRMNSC    = 14742.
XNPUT1     = 0.0000   XNPUT2        = 0.0000   XNPUT3    = 0.0000
TDEW       = 61.000  TA            = 75.0000   A1        = 8191.0
B1         = 8191.0   THETAC        = 8191.0   SA1       = 8191.0
SB1        = 8191.0   FLAP          = 8191.0   FEATHER   = 8191.0
NSIK2.5    = 1.5100   ASIK2.5       = -1.780    PSIK2.5   = .18500
RSIK2.5    = -.1590  YSIK2.5       = .20000    SSIK2.5   = -.0550
VSIK2.5    = 5.0003  N748          = -.4100    A748     = -.6960
P748       = -.0820  R748          = -.1590    Y748     = -.1640
S748       = 1.5210  V748          = 4.9970    PITCH    = 0.0000
ROLL       = 0.0000  GPITCH        = 0.9234E-01 GROLL     = 0.1000
  V48       = 4.9997  PA            = 2121.1    PTOT     = 2121.1
  QI        = 0.0000  JT1           = 106.82   JT2       = -30.040
  JT3       = -76.010 ELEV         = 0.0000  PITCHM   = 0.0000
RPMMR      = 0.0000  Q             = 0.0000  VEL       = 0.0000
PBAR       = 2121.2  PSTAT        = 2121.2  RN        = 0.0000
RHO        = 1.2256E-02 ALPHA      = 0.0000  BETA     = 0.0000
THETA      = 0.0000  PSI          = 0.0000  PHI      = 0.0000
HGT        = 0.0000  ALPHAU       = 0.0000  QUNCOR   = 0.0000
MACH       = 0.0000  NF1          = 12.123  AF1       = 2.4345
PM1        = 100.10  RM1          = 10.022  YM1       = 1.0000
SF1        = 1.2000  CNF1.B       = 12.123  CAF1.B    = 2.4345
CPM1.B     = 100.10  CRM1.B       = 10.022  CYM1.B    = 1.0000
CSF1.B     = 1.2000  CL1.S        = 12.123  CD1.S     = 2.4345
CPM1.S     = 100.10  CRM1.S       = 10.022  CYM1.S    = 1.0000
CSF1.S     = 1.2000
*****

```

***NOTE:** At the conclusion of a wind-off and the calculated data for a data point, the raw readings, in volts, for each channel used in the test, are listed to the operator's console. If the option to list to the line printer is active, then a hard copy of the data point and voltages will be printed also. The following page gives an example of what this information that follows the data point looks like. Also see ID Code of 0.

***** RAW DATA CHANNELS *****

1	TA	=	0.52337	2	TDEW	=	0.53782
3	A1	=	0.14876E-01	4	B1	=	-0.12543E-01
4	THETAC	=	0.14876E-01	5	SA1	=	0.12453E-01
6	SB1	=	0.14876E-01	7	FLAP	=	0.12453E-01
8	FEATHER	=	0.14876E-01	10	NSIK2.5	=	0.16451E-02
11	ASIK2.5	=	0.15176E-01	12	PSIK2.5	=	0.10921E-02
13	RSIK2.5	=	0.21566E-01	14	YSIK2.5	=	0.20051E-02
15	SSIK2.5	=	0.12876E-01	16	VSIK2.5	=	5.0024
17	N748	=	0.14876E-01	18	A748	=	0.19451E-02
19	P748	=	0.10916E-01	20	R748	=	0.22222E-02
21	Y748	=	0.14867E-01	22	S748	=	0.11215E-02
23	V748	=	4.9997	24	PITCH	=	0.23761E-02
25	ROLL	=	0.62134E-03	26	GPITCH	=	0.98342E-03
27	GROLL	=	0.99211E-03	32	V32	=	5.0012
97	PA	=	30065.	98	QI	=	0.0000
99	PTOT	=	30059.	100	JT1	=	0.0000
101	JT2	=	0.0000	102	JT3	=	0.0000
109	ELEV	=	87306.	110	PITCHM	=	63108.
111	RPMMR	=	0.0000				

*NOTE: OAP displays these same raw data channels in millivolts on pages 18 through 24 of the ISC display terminals.

DYNAMIC ZERO
(Identifier 3)

TEST 275 RUN 1 LAST POINT 0 ID 1

ENTER ?? FOR MENU OR NEW DATA ID
3
Waiting for data
Data complete
ENTER ?? FOR MENU OR NEW DATA ID

BALANCE SPAN
(Identifier 5)

ENTER ?? FOR MENU OR NEW DATA ID
5
ENTER VOLTAGE CHANNEL
16
ENTER SPAN CHANNEL (CR TO PRINT)
10

Press RETURN when ready with initial zero
or \$ to redo current channel.

Waiting for data
Data complete

The operator will be prompted to next press RETURN when a load has been applied to the balance component and finally to press RETURN when ready with the return zero. These three prompts will continue until each component of the six-component balance has been addressed. Once completed, the span results will print to the operator's console. Selecting ID Code 15 of the TXXX menu will cause a hard copy to output to the line printer. This process is repeated for each balance of the test.

SAMPLE OF BALANCE SPAN RESULTS

VOLTAGE IN CHANNEL 71 WAS 5.002

CHANNEL 65 ZERO	-.61274		
	SPAN	5.4145	
	ZERO	-.61375	SPAN-ZERO 6.0278
CHANNEL 66 ZERO	-.42079E-01		
	SPAN	6.0613	
	ZERO	-.47089E-01	SPAN-ZERO 6.1058
CHANNEL 67 ZERO	1.2166		
	SPAN	7.2527	
	ZERO	1.2226	SPAN-ZERO 6.0331
CHANNEL 68 ZERO	-1.4716		
	SPAN	4.6289	
	ZERO	-1.4676	SPAN-ZERO 6.0985
CHANNEL 69 ZERO	.36125		
	SPAN	6.3943	
	ZERO	.36125	SPAN-ZERO 6.0330
CHANNEL 70 ZERO	1.0897		
	SPAN	7.1330	
	ZERO	1.0907	SPAN-ZERO 6.0428

CALIBRATION
(Identifier 6)

TEST	273	RUN	31	POINT	9	ID	10
QCODE	1	MCODE	0	NBAL	1	SAMPLES	50
WCODE	0	CONF	0	TAPE	0	DBASE	1
PCODE	0	LIST	1	MPORT	0	IPOINT	0
IESP	1	SCODE	1	DEBUG	1	FMCODE	3
RLENGTH	232	VLENGTH	0				

TEST 275 RUN 1 LAST POINT 0 ID 0

ENTER ?? FOR MENU OR NEW DATA ID
6

SELECT OPTION FOR TYPE OF TRANSDUCER
0 - ABSOLUTE PRESSURE TRANSDUCERS
1 - OTHER PRESSURE TRANSDUCERS

WHICH OPTION DO YOU WANT?
0

ENTER CHANNEL NUMBERS TO BE CALIBRATED
12

CHANNELS BEING CALIBRATED:
12,

ENTER LOAD (1-3 VALUES) *
0
Waiting for data
Data complete

* If one is calibrating only one channel at a time, only one load will be entered at this point. That value will be stored on the database in XNPUT1. If two or three channels are being calibrated simultaneously, the loads for each channel will be entered with a space separating each entry (e.g., 100 150 200). These values will be stored on the database in XNPUT1, XNPUT2, and XNPUT3 respectively. Once the calibration is completed, the operator should invoke the stand-alone task, LSQ in order to obtain the sensitivity constant. See section 11.0.

RECALL ZEROS
(Identifier 7)

ENTER ?? FOR MENU OR NEW DATA ID

7

***** 1/07/83 13:45:50 *****

ZEROS FOR RUN 136 POINT 12

TA = 0.0000 (0.0000)	TDEW = 0.0000 (0.0000)
A1 = 0.14876E-01 (0.12345E-01)	B1 = -0.12453E-01(-0.13587E-01)
THETAC = 0.14876E-01 (0.12345E-01)	SA1 = -0.12453E-01(-0.13587E-01)
SB1 = 0.14876E-01 (0.12345E-01)	FLAP = -0.12453E-01(-0.13587E-01)
FEATHER = 0.14876E-01 (0.12345E-01)	NSIK2.5 = 0.16451E-02 (0.16234E-02)
ASIK2.5 = 0.15176E-01 (0.15235E-01)	PSIK2.5 = 0.10921E-02 (0.10834E-02)
RSIK2.5 = 0.21566E-01 (0.20111E-01)	YSIK2.5 = 0.20051E-02 (0.19234E-02)
SSIK2.5 = 0.12876E-01 (0.12345E-01)	VSIK2.5 = 0.0000 (0.0000)
CHORD = 0.0000 (0.0000)	PITCH = 0.0000 (0.0000)
ROLL = 0.0000 (0.0000)	GPITCH = 0.0000 (0.0000)
GROLL = 0.0000 (0.0000)	V32 = 0.0000 (0.0000)
PA = 0.0000 (0.0000)	QI = 0.0000 (0.0000)
PTOT = 0.0000 (0.0000)	JT1 = 0.0000 (0.0000)
JT2 = 0.0000 (0.0000)	JT3 = 0.0000 (0.0000)
ELEV = 0.0000 (0.0000)	PITCHM = 0.0000 (0.0000)
RPMMR = 0.0000 (0.0000)	
THETAZ = 0.13 PHIZ = 0.00	

DO YOU WANT TO SWITCH ZEROS? (Y-N)

Y

***** 1/07/83 13:45:50 *****

ZEROS FOR RUN 136 POINT 12

TA = 0.0000 (0.0000)	TDEW = 0.0000 (0.0000)
A1 = 0.12345E-01 (0.14876E-01)	B1 = -0.13587E-01(-0.12453E-01)
THETAC = 0.12345E-01 (0.14876E-01)	SA1 = -0.13587E-01(-0.12453E-01)
SB1 = 0.12345E-01 (0.14876E-01)	FLAP = -0.13587E-01(-0.12453E-01)
FEATHER = 0.12345E-01 (0.14876E-01)	NSIK2.5 = 0.16234E-02 (0.16451E-02)
ASIK2.5 = 0.15235E-01 (0.15176E-01)	PSIK2.5 = 0.10834E-02 (0.10921E-02)
RSIK2.5 = 0.2011E-01 (0.21566E-01)	YSIK2.5 = 0.19234E-02 (0.20051E-02)
SSIK2.5 = 0.12345E-01 (0.12876E-01)	VSIK2.5 = 0.0000 (0.0000)
CHORD = 0.0000 (0.0000)	PITCH = 0.0000 (0.0000)
ROLL = 0.0000 (0.0000)	GPITCH = 0.0000 (0.0000)
GROLL = 0.0000 (0.0000)	V32 = 0.0000 (0.0000)
PA = 0.0000 (0.0000)	QI = 0.0000 (0.0000)
PTOT = 0.0000 (0.0000)	JT1 = 0.0000 (0.0000)
JT2 = 0.0000 (0.0000)	JT3 = 0.0000 (0.0000)
ELEV = 0.0000 (0.0000)	PITCHM = 0.0000 (0.0000)
RPMMR = 0.0000 (0.0000)	
THETAZ = 0.13 PHIZ = 0.00	

TEST273 RUN 276 LAST POINT 13 ID 7

ENTER??FOR MENU OR NEW DATA ID

**RUN SUMMARY
(IDENTIFIER 9)**

ENTER ?? FOR MENU OR NEW DATA ID

9

RUNS:

1	2	3	4	5	6	7	8	9	10
11	12	13	14	15	16	18	19	20	21

ENTER RUN NUMBER

65

ENTER RUN NUMBER

The results of a run summary may be several pages of the following format:

Page 1 - The first eight support parameters (ALPHA, BETA, THETA, PSI, PHI, HGT, ALPHAU, and QUNCOR)

Pages 2 - The six forces and moments parameters for the first balance (NF1, AF1, PM1, RM1, YM1, and SF1)

If there are two or more balances, the next page(s) would contain the forces and moments for that balance. Afterwards, calculations stored in the PLIST array would be printed. Finally, there would be a printout of all channels assigned to the test. Below is a sample printout.

PAGE 2 RUN 65 9/30/82 21:38:27

POINT	NF1	AF1	PM1	RM1	YM1	SF1
5.0000	354.11	-22.845	176.19	-174.00	1136.2	-2.3563
6.0000	390.75	-26.459	174.01	-183.90	1230.0	-2.3004
7.0000	440.65	-31.247	180.22	-217.19	1350.1	-3.3970
8.0000	468.26	-34.573	175.87	-236.63	1446.4	-3.4302
9.0000	506.32	-38.551	178.73	-268.67	1550.9	-4.5080
10.000	545.53	-41.419	202.59	-314.78	1685.7	-6.0749
11.000	576.61	-46.694	180.24	-338.07	1806.4	-5.9792
12.000	620.87	-50.957	191.03	-393.60	1970.4	-7.8424
13.000	661.79	-55.332	189.89	-462.50	2144.7	-10.716

* **NOTE:** ID OF 9 must be followed by ID of 15 in order for the run summary to print on the system printer.

MODIFY OPTIONS
(Identifier 10)

TEST 273 RUN 1 LAST POINT 0 ID 0

ENTER ?? FOR MENU OR NEW DATA ID
10

TEST	273	RUN	31	POINT	9	ID	10
QCODE	1	MCODE	0	NBAL	1	SAMPLES	50
WCODE	0	CONF	0	TAPE	0	DBASE	1
PCODE	0	LIST	1	MPORT	0	IPOINT	0
IESP	1	SCODE	1	DEBUG	1	FMCODE	3
RLENGTH232		VLENGTH	0				

ENTER NAME OF PARAMETER TO CHANGE OR CR FOR NONE
TEST

TEST	273	RUN	31	POINT	9	ID	10
QCODE	1	MCODE	0	NBAL	1	SAMPLES	50
WCODE	0	CONF	0	TAPE	0	DBASE	1
PCODE	0	LIST	1	MPORT	0	IPOINT	0
IESP	1	SCODE	1	DEBUG	1	FMCODE	3
RLENGTH232		VLENGTH	0				

ENTER NAME OF PARAMETER TO CHANGE OR CR FOR NONE
RUN

RUN NUMBER IS 1
ENTER ANY CHANGE

TEST	273	RUN	31	POINT	9	ID	10
QCODE	1	MCODE	0	NBAL	1	SAMPLES	50
WCODE	0	CONF	0	TAPE	0	DBASE	1
PCODE	0	LIST	1	MPORT	0	IPOINT	0
IESP	1	SCODE	1	DEBUG	1	FMCODE	3
RLENGTH232		VLENGTH	0				

ENTER NAME OF PARAMETER TO CHANGE OR CR FOR NONE
POINT

POINT NUMBER IS 0
ENTER ANY CHANGE

TEST	273	RUN	31	POINT	9	ID	10
QCODE	1	MCODE	0	NBAL	1	SAMPLES	50
WCODE	0	CONF	0	TAPE	0	DBASE	1
PCODE	0	LIST	1	MPORT	0	IPOINT	0
IESP	1	SCODE	1	DEBUG	1	FMCODE	3
RLENGTH232		VLENGTH	0				

ENTER NAME OF PARAMETER TO CHANGE OR CR FOR NONE

ID

TEST	273	RUN	31	POINT	9	ID	10
QCODE	1	MCODE	0	NBAL	1	SAMPLES	50
WCODE	0	CONF	0	TAPE	0	DBASE	1
PCODE	0	LIST	1	MPORT	0	IPOINT	0
IESP	1	SCODE	1	DEBUG	1	FMCODE	3
RLENGTH232		VLENGTH	0				

ENTER NAME OF PARAMETER TO CHANGE OR CR FOR NONE
QCODE

Q CODE IS 0 (See Section 9.0)
 0 - IS FOR STATIC TEST
 1 - IS FOR QPROBE
 2 - IS FOR CLOSED TEST SECTION
 3 - IS FOR CLOSED TEST SECTION WITH B.L. SUCTION
 4 - IS FOR OPEN TEST SECTION
 5 - IS FOR OPEN TEST SECTION WITH B.L. SUCTION
 6 - IS FOR OPEN TEST SECTION WITH ACOUSTIC PANELS
 ENTER ANY CHANGE

TEST	273	RUN	31	POINT	9	ID	10
QCODE	1	MCODE	0	NBAL	1	SAMPLES	50
WCODE	0	CONF	0	TAPE	0	DBASE	1
PCODE	0	LIST	1	MPORT	0	IPOINT	0
IESP	1	SCODE	1	DEBUG	1	FMCODE	3
RLENGTH232		VLENGTH	0				

ENTER NAME OF PARAMETER TO CHANGE OR CR FOR NONE

TEST	273	RUN	31	POINT	9	ID	10
QCODE	1	MCODE	0	NBAL	1	SAMPLES	50
WCODE	0	CONF	0	TAPE	0	DBASE	1
PCODE	0	LIST	1	MPORT	0	IPOINT	0
IESP	1	SCODE	1	DEBUG	1	FMCODE	3
RLENGTH232		VLENGTH	0				

ENTER NAME OF PARAMETER TO CHANGE OR CR FOR NONE
MCODE

MODEL ROLL ATTITUDE IS .0 DEGREES

***NOTE:** MCODE is defined with reference to the airplane body axis (i.e. positive rotation is defined as right wing down).

TEST	273	RUN	31	POINT	9	ID	10
QCODE	1	MCODE	0	NBAL	1	SAMPLES	50
WCODE	0	CONF	0	TAPE	0	DBASE	1
PCODE	0	LIST	1	MPORT	0	IPOINT	0
IESP	1	SCODE	1	DEBUG	1	FMCODE	3
RLENGTH232		VLENGTH	0				

ENTER NAME OF PARAMETER TO CHANGE OR CR FOR NONE
TAPE

SAVE DATA ON TAPE? (Y?N) (N)
ENTER ANY CHANGE

TEST	273	RUN	31	POINT	9	ID	10
QCODE	1	MCODE	0	NBAL	1	SAMPLES	50
WCODE	0	CONF	0	TAPE	0	DBASE	1
PCODE	0	LIST	1	MPORT	0	IPOINT	0
IESP	1	SCODE	1	DEBUG	1	FMCODE	3
RLENGTH232		VLENGTH	0				

ENTER NAME OF PARAMETER TO CHANGE OR CR FOR NONE
DBASE

SAVE DATA ON DBASE? (Y/N) (N)
ENTER ANY CHANGE

TEST	273	RUN	31	POINT	9	ID	10
QCODE	1	MCODE	0	NBAL	1	SAMPLES	50
WCODE	0	CONF	0	TAPE	0	DBASE	1
PCODE	0	LIST	1	MPORT	0	IPOINT	0
IESP	1	SCODE	1	DEBUG	1	FMCODE	3
RLENGTH232		VLENGTH	0				

ENTER NAME OF PARAMETER TO CHANGE OR CR FOR NONE
PCODE

SURFACE PRESSURE CODE (0)

- 0 - P
- 1 - P+Pa
- 2 - CP

ENTER ANY CHANGE

*NOTE: In the options above, P indicates differential pressure - P+Pa indicates absolute pressure - CP pressure coefficients. If PCODE is a 1 or a 2, select ID code of 14 and make sure that ESP scale factor is set to 144.

TEST	273	RUN	31	POINT	9	ID	10
QCODE	1	MCODE	0	NBAL	1	SAMPLES	50
WCODE	0	CONF	0	TAPE	0	DBASE	1
PCODE	0	LIST	1	MPORT	0	IPOINT	0
IESP	1	SCODE	1	DEBUG	1	FMCODE	3
RLENGTH232		VLENGTH	0				

ENTER NAME OF PARAMETER TO CHANGE OR CR FOR NONE

LIST

LIST ON LINE PRINTER? (Y/N) (N)
ENTER ANY CHANGE

LIST AFTER EACH DATA POINT? (Y/N) (Y)

***NOTE:** If the desire is to list after every data point, LIST will be set to 1. If not, LIST will be set to 2 and output to the printer will occur only after the TXXX task is exited or LIST is changed to 1. If LIST is off, make sure that DEBUG is disabled also.

TEST	273	RUN	31	POINT	9	ID	10
QCODE	1	MCODE	0	NBAL	1	SAMPLES	50
WCODE	0	CONF	0	TAPE	0	DBASE	1
PCODE	0	LIST	1	MPORT	0	IPOINT	0
IESP	1	SCODE	1	DEBUG	1	FMCODE	3
RLENGTH232		VLENGTH	0				

ENTER NAME OF PARAMETER TO CHANGE OR CR FOR NONE
WCODE

WALL CODE IS 0
0 IS FOR NO WALL CORRECTIONS
1 IS FOR WALL CORRECTIONS - WALLS DOWN
2 IS FOR WALL CORRECTIONS - WALLS UP
3 IS FOR JET BOUNDARY CORRECTIONS

***NOTE:** It is very important that particular attention be paid to the correct setting of this code. It does not refer to the test section configuration. Wall or jet boundary corrections are provided by the test engineer and set by the data reduction group. If these corrections are not input and a wall code other than 0 is used, the Q will be computed as 0.

ENTER ANY CHANGE

TEST	273	RUN	31	POINT	9	ID	10
QCODE	1	MCODE	0	NBAL	1	SAMPLES	50
WCODE	0	CONF	0	TAPE	0	DBASE	1
PCODE	0	LIST	1	MPORT	0	IPOINT	0
IESP	1	SCODE	1	DEBUG	1	FMCODE	3
RLENGTH232		VLENGTH	0				

ENTER NAME OF PARAMETER TO CHANGE OR CR FOR NONE

CONF

***NOTE:** This parameter is an additional test parameter determined by the engineer to serve as an indicator as to how the data is taken. A maximum of six digits may be used if the number is positive ----- five, if the number is negative.

CONFIGURATION CODE IS 0
ENTER ANY CHANGE

TEST	273	RUN	31	POINT	9	ID	10
QCODE	1	MCODE	0	NBAL	1	SAMPLES	50
WCODE	0	CONF	0	TAPE	0	DBASE	1
PCODE	0	LIST	1	MPORT	0	IPORT	0
IESP	1	SCODE	1	DEBUG	1	FMCODE	3
RLENGTH232		VLENGTH	0				

ENTER NAME OF PARAMETER TO CHANGE OR CR FOR NONE
IESP See Section 7.0

ESP DATA?? 0 = NONE, 1 = ESP 1, 2 = ESP 2, 3 = BOTH (0)
ENTER ANY CHANGE

TEST	273	RUN	31	POINT	9	ID	10
QCODE	1	MCODE	0	NBAL	1	SAMPLES	50
WCODE	0	CONF	0	TAPE	0	DBASE	1
PCODE	0	LIST	1	MPORT	0	IPORT	0
IESP	1	SCODE	1	DEBUG	1	FMCODE	3
RLENGTH232		VLENGTH	0				

ENTER NAME OF PARAMETER TO CHANGE OR CR FOR NONE
SCODE

STING CODE IS 0
0 IS FOR NO STING
1 IS FOR NORMAL STING
2 IS FOR ROLL STING
3 IS FOR STRUT
ENTER ANY CHANGE

TEST	273	RUN	31	POINT	9	ID	10
QCODE	1	MCODE	0	NBAL	1	SAMPLES	50
WCODE	0	CONF	0	TAPE	0	DBASE	1
PCODE	0	LIST	1	MPORT	0	IPORT	0
IESP	1	SCODE	1	DEBUG	1	FMCODE	3
RLENGTH232		VLENGTH	0				

ENTER NAME OF PARAMETER TO CHANGE OR CR FOR NONE

DEBUG

FORCE DATA DEBUG OPTION? (Y/N) (N)
ENTER ANY CHANGE

1 - print intermediate values for balance data calculations.

0 - no intermediate values printed.

***NOTE:** Set to "0" if LIST is disabled.

TEST	273	RUN	31	POINT	9	ID	10
QCODE	1	MCODE	0	NBAL	1	SAMPLES	50
WCODE	0	CONF	0	TAPE	0	DBASE	1
PCODE	0	LIST	1	MPORT	0	IPOINT	0
IESP	1	SCODE	1	DEBUG	1	FMCODE	3
RLENGTH	232	VLENGTH	0				

ENTER NAME OF PARAMETER TO CHANGE OR CR FOR NONE
FMCODE

FLOWMETER CODE IS 0
 0 IS FOR NO FLOWMETER
 1 IS FOR FM NO. 1 (AREA = .001087)//
 2 IS FOR FM NO. 2 (AREA = .003438)//
 3 IS FOR FM NO. 3 (AREA = .008486)//
 4 IS FOR FM NO. 4 (AREA = .001076)//
 5 IS FOR FM NO. 5 (AREA = .00259)//
 6 IS FOR FM NO. 6 (AREA = .007176)//
 7 IS FOR FM NO. 7 (AREA = .010721)//
 8 IS FOR FM NO. 8 (AREA = .001085)//
 9 IS FOR FM NO. 9 (AREA = .00109)//

ENTER ANY CHANGE

TEST	273	RUN	31	POINT	9	ID	10
QCODE	1	MCODE	0	NBAL	1	SAMPLES	50
WCODE	0	CONF	0	TAPE	0	DBASE	1
PCODE	0	LIST	1	MPORT	0	IPOINT	0
IESP	1	SCODE	1	DEBUG	1	FMCODE	3
RLENGTH	232	VLENGTH	0				

ENTER NAME OF PARAMETER TO CHANGE OR CR FOR NONE
RLENGTH See Section 10.0 (Setting Height)

Longitudinal distance from mast to model reference point is 0 inches. ENTER ANY CHANGE

232

TEST	273	RUN	31	POINT	9	ID	10
QCODE	1	MCODE	0	NBAL	1	SAMPLES	50
WCODE	0	CONF	0	TAPE	0	DBASE	1
PCODE	0	LIST	1	MPORT	0	IPOINT	0
IESP	1	SCODE	1	DEBUG	1	FMCODE	3
RLENGTH	232	VLENGTH	0				

ENTER NAME OF PARAMETER TO CHANGE OR CR FOR NONE
VLENGTH See Section 10.0 (Setting Height)

Vertical distance from pivot center on vertical strut to model reference is 0 inches.
ENTER ANY CHANGE

TEST	273	RUN	31	POINT	9	ID	10
QCODE	1	MCODE	0	NBAL	1	SAMPLES	50
WCODE	0	CONF	0	TAPE	0	DBASE	1
PCODE	0	LIST	1	MPORT	0	IPOINT	0
IESP	1	SCODE	1	DEBUG	1	FMCODE	3
RLENGTH232		VLENGTH	0				

ENTER NAME OF PARAMETER TO CHANGE OR CR FOR NONE
NBAL

NUMBER OF BALANCES IS 1
ENTER ANY CHANGE

TEST	273	RUN	31	POINT	9	ID	10
QCODE	1	MCODE	0	NBAL	1	SAMPLES	50
WCODE	0	CONF	0	TAPE	0	DBASE	1
PCODE	0	LIST	1	MPORT	0	IPOINT	0
IESP	1	SCODE	1	DEBUG	1	FMCODE	3
RLENGTH232		VLENGTH	0				

ENTER NAME OF PARAMETER TO CHANGE OR CR FOR NONE
SAMPLES

NUMBER OF CYCLES 0
ENTER ANY CHANGE

TEST	273	RUN	31	POINT	9	ID	10
QCODE	1	MCODE	0	NBAL	1	SAMPLES	50
WCODE	0	CONF	0	TAPE	0	DBASE	1
PCODE	0	LIST	1	MPORT	0	IPOINT	0
IESP	1	SCODE	1	DEBUG	1	FMCODE	3
RLENGTH232		VLENGTH	0				

ENTER NAME OF PARAMETER TO CHANGE OR CR FOR NONE

***NOTE:** With the NEFF 620/600, the number of samples used in an averaged data point is exactly whatever value is assigned to SAMPLES. The samples grabbed by the software are not necessarily contiguous.

CALCULATE TARES
(Identifier 11)

TEST 273 RUN 276 LAST POINT 13 ID 7
ENTER ?? FOR MENU OR NEW DATA ID
11
NOT ENOUGH TARE POINTS (5 MINIMUM)

TEST 273 RUN 276 LAST POINT 13 ID 11
ENTER?? FOR MENU OR NEW DATA ID

If tares had been taken, calculated values for WT, WTN, XBAR, YBAR, ZBAR, PHIO, and THETAO would be displayed at this time. These same values may be viewed at anytime by selecting option 13. It is in option 13 that the values for WT, WTN, XBAR, YBAR, ZBAR, PHIO, and THETAO may be changed to reflect an earlier tare calculation.

MODIFICATION OF CHANNELS
(Identifier 12)

OPTIONS 'A' TO ADD A CHANNEL
'D' TO DELETE A CHANNEL
'M' TO MODIFY A CHANNEL PARAMETER
'L' TO LIST SETUP
'P' TO PRINT SETUP
'E' TO EXIT MAKING NO CHANGES
' ' TO CONTINUE

Do you wish to modify user parameters? (Y/N)
N

User parameters are in a 100-word array, which can be changed inter-actively through TXXX. The values may be channel numbers, constants, curve fit coefficients, codes, etc.

Channel parameter names may be any name the user desires, provided that each name is no longer than eight characters. However, there are certain names which the data reduction program requires for certain parameters.

The specific names are PITCH, ROLL, YAW, PA, QI, JT1, JT2, JT3, PST, TA, TDEW, PITOT, ELEV, PITCHM, PTOT, FMTDE, FMDELP, FMP1, GPITCH, and GROLL.

OPTIONS 'A' TO ADD A CHANNEL
'D' TO DELETE A CHANNEL
'M' TO MODIFY A CHANNEL PARAMETER
'L' TO LIST SETUP
'P' TO PRINT SETUP
'E' TO EXIT MAKING NO CHANGES
' ' TO CONTINUE

M

ENTER CHANNEL TO MODIFY
81
81 not in table

OPTIONS 'A' TO ADD A CHANNEL
'D' TO DELETE A CHANNEL
'M' TO MODIFY A CHANNEL PARAMETER
'L' TO LIST SETUP
'P' TO PRINT SETUP
'E' TO EXIT MAKING NO CHANGES
' ' TO CONTINUE

M

ENTER CHANNEL TO MODIFY

50

ENTER CHANNEL TYPE (4)

Identifier 12 - Continued

ENTER SENSITIVITY CONSTANT (9.6922)(Identifier 12) (Continued)

ENTER ZERO (-.14780E-01)

ENTER OFFSET (.00000)

ENTER LOWER & UPPER LIMITS (-.90000E+21 .90000E+21)

ENTER NAME OF PARAMETER (AOACL2)

ENTER UNITS(DEG)

ENTER REF. VOLTAGE CHANNEL (0)

ENTER REF. VOLTAGE (.00000)

ENTER REF. LOAD (.00000)

OPTIONS ' A ' TO ADD A CHANNEL

' D ' TO DELETE A CHANNEL

' M ' TO MODIFY A CHANNEL PARAMETER

' L ' TO LIST SETUP

' P ' TO PRINT SETUP

' E ' TO EXIT MAKING NO CHANGES

' ' TO CONTINUE

L or P

***NOTE:** "L" will list to terminal screen; "P" will list to line printer

Identifier 12 - Continued

CH	TYPE	CON	ZERO	OFFSET	REF.	VOLT	NAME	UNIT
1	2	35.211	.00000	32.000	0	.000	TA	DEGF
2	2	1.1200	.00000	32.000	0	.000	TDEW	DEGF
3	3	1850.2	.00000	.00000	0	.000	PITCH	DEG
4	0	1.0000	.00000	.00000	0	.000	PST	PSI
5	2	35.211	.00000	32.000	0	.000	FMTEMP	DEGF
6	2	1.0000	.00000	.00000	0	.000	DELP	PSI
10	0	1.0000	.00000	.00000	0	.000	QTOP	PSF
11	0	1.0000	.00000	.00000	0	.000	QBOTTOM	PSF
12	0	1.0000	.00000	.00000	0	.000	BPIT1	DEG
13	0	1.0000	.00000	.00000	0	.000	BYAW1	DEG
14	0	1.0000	.00000	.00000	0	.000	BPIT2	DEG
15	0	1.0000	.00000	.00000	0	.000	BYAW2	DEG
49	4	9.9750	.48795E-02	.00000	0	.000	AOACL1	DEG
50	4	9.6922	-.14780E-01	.00000	0	.000	AOACL2	DEG
51	0	1.0000	.00000	.00000	0	.000	AOAHW	DEG
52	0	1.0000	.00000	.00000	0	.000	QHW	PSF
53	2	1.0000	.00000	.00000	0	.000	VAIF4	VOLTS
54	2	1.0000	.00000	.00000	0	.000	VAIF5	VOLTS
64	0	1.0000	.00000	.00000	0	.000	VRMS1	VOLTS
65	0	1.0000	.00000	.00000	0	.000	VRMS2	VOLTS
66	0	1.0000	.00000	.00000	0	.000	VRMS3	VOLTS
67	0	1.0000	.00000	.00000	0	.000	VRMS4	VOLTS
68	0	1.0000	.00000	.00000	0	.000	VRMS5	VOLTS
69	0	1.0000	.00000	.00000	0	.000	VDC1	VOLTS
70	0	1.0000	.00000	.00000	0	.000	VDC2	VOLTS
71	0	1.0000	.00000	.00000	0	.000	VDC3	VOLTS
72	0	1.0000	.00000	.00000	0	.000	VDC4	VOLTS
73	0	1.0000	.00000	.00000	0	.000	VDC5	VOLTS
97	2	.70729E-01	.00000	.00000			PA	PSF
98	2	.10000E-00	.00000	.00000			QI	PSF
99	0	1.0000	.00000	.00000			QLEFT	PSF
100	0	1.0000	.00000	.00000			QRIGHT	PSF
101	0	1.0000	.00000	.00000			QIS	PSF
107	2	.10000E-01	.00000	.00000			YAW	DEG
108	2	.10000E-01	.00000	.00000			PITCHM	DEG
109	2	-.31250E-02	.00000	.00000			ELEV	IN
110	0	1.0000	.00000	.00000			BLOC1	FT
111	0	1.0000	.00000	.00000			BLOC2	FT
112	2	.83333	.00000	.00000			BTACH1	RPM
113	2	.83333	.00000	.00000			BTACH2	RPM

Identifier 12 - Continued

OPTIONS 'A' TO ADD A CHANNEL
'D' TO DELETE A CHANNEL
'M' TO MODIFY A CHANNEL PARAMETER
'L' TO LIST SETUP
'P' TO PRINT SETUP
'E' TO EXIT MAKING NO CHANGES
' ' TO CONTINUE

A

ENTER NEW CHANNEL NUMBER

4

ENTER CHANNEL TYPE (0)

ENTER SENSITIVITY CONSTANT (1.0000)

ENTER ZERO (.00000)

ENTER OFFSET (.00000)

ENTER LOWER & UPPER LIMITS (-.90000E+21 .90000E+21)

ENTER NAME OF PARAMETER (EUNIT4)

ENTER UNITS()

ENTER REF. VOLTAGE CHANNEL (0)

ENTER REF. VOLTAGE (.00000)

ENTER REF. LOAD (2.4261)

ENTER NEW CHANNEL NUMBER

OPTIONS 'A' TO ADD A CHANNEL
'D' TO DELETE A CHANNEL
'M' TO MODIFY A CHANNEL PARAMETER
'L' TO LIST SETUP
'P' TO PRINT SETUP
'E' TO EXIT MAKING NO CHANGES
' ' TO CONTINUE

Identifier 12 - Continued

D

ENTER CHANNEL TO DELETE

4

OPTIONS 'A' TO ADD A CHANNEL
'D' TO DELETE A CHANNEL
'M' TO MODIFY A CHANNEL PARAMETER
'L' TO LIST SETUP
'P' TO PRINT SETUP
'E' TO EXIT MAKING NO CHANGES
' ' TO CONTINUE

TEST 300 RUN 9 LAST POINT 0 ID 12

ENTER ?? FOR MENU OR NEW DATA ID

***NOTE:** Options 'D' and 'M' allow the user to enter either the channel number or the channel name. Whenever "E" is used to exit ID code of 12, any changes made will not be saved to disk. In order to save changes, simply do a c/r, which is the last option in the menu for ID code of 12.

MODIFICATION OF BALANCE PARAMETERS
(Identifier 13)

ENTER ?? FOR MENU OR NEW DATA ID
13

BALANCES NSIK25 B748B

ENTER NUMBER OF BALANCES (2)

ENTER BALANCE NAME (NSIK25)

Do you wish to read a balance deck?

DO YOU HAVE CORRECTIONS FOR WALLS DOWN?* *SEE TEST ENGINEER'S
MANUAL 5.4.6

DO YOU HAVE CORRECTIONS FOR WALLS UP?*

JET BOUNDARY CORRECTIONS CONSIST OF*

J1 (CORRECTION FOR DRAG)

J2 (CORRECTION FOR ALPHA)

J3 (CORRECTION FOR PITCH)

BCF (BLOCKAGE FACTOR = KWBI+KWDI)

ENTER J1,J2,J3,BCF

(.00000 .00000 .00000 .00000)

ENTER CHANNEL NUMBER (17)

ENTER BALANCE TYPE (0)

0 - N,A,P,R,Y,S

1 - N1,A,N2,R,S1,S2

ENTER S C B

(10.171 15.500 94.484)

ENTER XTRAN YTRAN ZTRAN

(6.3170 .00000 .00000)

ENTER ROTATION ANGLES

(.00000 .00000 .00000)

ENTER WT AND WTN

(277.72 282.29)

ENTER XBAR, YBAR, ZBAR

(-4.6867 .41299E-01 -1.8082)

ENTER PHIO AND THETAO

(-.14240E-01 .25000)

Identifier 13 - Continued

Do you wish to enter sting interactions and/or pressure tares
N

***NOTE:** If no, the screen will display:
ENTER?? FOR MENU OR NEW DATA ID

Do you wish to enter sting interactions and/or pressure tares
Y

ENTER STING INTERACTIONS FOR COMPONENT 1
1.0000 .00000 .00000 .00000 .00000 .00000

ENTER PRESSURE TARES
.00000 .00000 .00000 .00000 .00000 .00000

***NOTE:** You will have the opportunity to enter the sting
interactions and pressure tares for all six components.

ENTER ?? FOR MENU OR NEW DATA ID
13

BALANCES NSIK25 B748

ENTER NUMBER OF BALANCES (2)

ENTER BALANCE NAME (NSIK25)

Do you wish to read a balance deck?
N

DO YOU HAVE CORRECTIONS FOR WALLS DOWN?
Y

WALL CORRECTIONS CONSIST OF

CD/CL (5 TERMS), DEL ALPHA (15 TERMS), and DEL Q (15 TERMS)

ENTER CD/CL
(-.40000)

ENTER DELTA ALPHA
(.26800E-01 2.5364 -.25506)

ENTER DELTA Q
(1.0005 .24526E-01 -.59169E-02)

Identifier 13 - Continued

DO YOU HAVE CORRECTIONS FOR WALLS UP?
Y

WALL CORRECTIONS CONSIST OF
CD/CL (5 TERMS), DEL ALPHA (15 TERMS) AND DEL Q (15 TERMS)

ENTER CD/CL
(-.20000)

ENTER DELTA ALPHA (-.10215E-01 -2.1793 .25197)

ENTER DELTA Q -.45845E-01 .43972E-02)
(.99954

ENTER CD/CL
(.00000)

***NOTE:** If there are wall corrections, the wall code must be set in ID code 10 to 1 for walls down or 2 for walls up. If the response had been that there were no wall corrections, the operator would have been prompted to enter the jet boundary corrections (if any). If, indeed, jet boundary corrections are to be applied to the Q, α , lift, and drag, the wall code must be set to 3.

MISCELLANEOUS OPTIONS
(Identifiers 14, 15, 16, 17, 20,21)

TEST 273 RUN 276 LAST POINT 13 ID 14

ENTER ?? FOR MENU OR NEW DATA ID

14

Do you want to input the strips? (Y/N)

Enter pressure units factors for ESP See Section 7.2 for more details
(144.00)

TEST 273 RUN 276 LAST POINT 13 ID 14

ENTER ?? FOR MENU OR NEW DATA ID

15

(This option allows data on the print buffer to be sent to the printer.)

TEST 273 RUN 276 LAST POINT 13 ID 15

ENTER ?? FOR MENU OR NEW DATA ID

16

(This option causes an EOF to be written on the data tape and the tape to be rewound.)

TEST 273 RUN 276 LAST POINT 13 ID 16

ENTER ?? FOR MENU OR NEW DATA ID

17

(This option allows for the selection of the correct flowmeter setup file)

Enter BIOS file name for flowmeter constants.

ADF

READING CONSTANTS FOR FLOWMETER 3

TEST 273 RUN 276 LAST POINT 13 ID 17

ENTER ?? FOR MENU OR NEW DATA ID

20

Enter desired Laird Telemedia (ex. 1 2 3 &/or 4) ***NOTE:** Select the number of Lairds used.

1

***** LAIRD TELEMEDIA SETUP *****

- 1 - Time, date, run, and point number only.
- 2 - Time, date, and 42 user characters.
- 3 - Run, point, and 48 user characters.
- 4 - Time, date, run, point, and 30 characters.
- 5 - Two 30 character use specified lines.
- 6 - Time, date, run, point, and 2 test parameters.
- 7 - Stop Laird Telemedia update task.

ENTER OPTION NUMBER UNIT # 1 OR \$\$ TO EXIT:

4

ENTER 30 CHARACTERS FOR 2ND LINE

XXXXXXXXXXXXXXXXXXXXXXXXXXXX

DUMMY TEST NUMBER 298

*** LAIRD TELEMEDIA SETUP ***

- 1 - Time, date, run, and point number only.
- 2 - Time, date, and 42 user characters.
- 3 - Run, point, and 48 user characters.
- 4 - Time, date, run, point, and 30 characters.
- 5 - Two 30 character use specified lines.
- 6 - Time, date, run, point, and 2 test parameters.
- 7 - Stop Laird Telemedia update task.

ENTER OPTION NUMBER UNIT # 1 OR \$\$ TO EXIT:

\$\$

TEST 361 RUN 3 LAST POINT 0 ID 20

ENTER ?? FOR MENU OR NEW DATA ID

21

(This option causes a calibration of the ESPs to occur within the TXXX task)

CALIBRATION OF ESPS REQUESTED

I 00102 12:26:01 06 * * 3 POINT ESP CALIBRATION REQUESTED * *

ENTER ESP SYSTEM TO CALIBRATE

1. ESP1 SYSTEM
2. ESP2 SYSTEM
3. BOTH SYSTEMS
- E. EXIT

ENTER (1, 2, 3, E) >

1

I 00102 12:30:45 06 * * 3 POINT CALIBRATION COMPLETE FOR ESP1 * *

CALIBRATION COMPLETE

TEST 361 RUN 3 LAST POINT 0 ID 21

ENTER ?? FOR MENU OR NEW DATA ID

TACHOMETER RANGE CONTROL
(Identifier 22)

TEST 361 RUN 3 LAST POINT 0 ID 24

ENTER ?? FOR MENU OR NEW DATA ID

22

MODACS Tach. input words: 0 0

* TACHOMETER RANGE CONTROL *

TIF#	CHAN#	RANGE	TIF#	CHAN#	RANGE
1	1	0.1 SEC	2	1	0.1 SEC
1	2	0.1 SEC	2	2	0.1 SEC
1	3	0.1 SEC	2	3	0.1 SEC
1	4	0.1 SEC	2	4	0.1 SEC
1	5	0.1 SEC	2	5	0.1 SEC
1	6	0.1 SEC	2	6	0.1 SEC
1	7	0.1 SEC	2	7	0.1 SEC
1	8	0.1 SEC	2	8	0.1 SEC

DO YOU WISH TO MODIFY SETTINGS (Y/N)

Y

ENTER TIF NUMBER TO BE MODIFIED (1,2)

1

ENTER CHANNEL # (1-8)

2

ENTER DESIRED RANGE #

1 - 0.1 SEC

2 - 1.0 SEC

3 - 10.0 SEC

4 - PERIOD

1

MODACS Tach. output words: 0 0

MODACS Tach. input words: 0 0

* TACHOMETER RANGE CONTROL *

TIF#	CHAN#	RANGE	TIF#	CHAN#	RANGE
1	1	0.1 SEC	2	1	0.1 SEC
1	2	0.1 SEC	2	2	0.1 SEC
1	3	0.1 SEC	2	3	0.1 SEC
1	4	0.1 SEC	2	4	0.1 SEC
1	5	0.1 SEC	2	5	0.1 SEC
1	6	0.1 SEC	2	6	0.1 SEC
1	7	0.1 SEC	2	7	0.1 SEC
1	8	0.1 SEC	2	8	0.1 SEC

DO YOU WISH TO MODIFY SETTINGS (Y/N)

TEST 361 RUN 3 LAST POINT 0 ID 24

ENTER ?? FOR MENU OR NEW DATA ID

REAL-TIME PLOTS
(Identifier 24)

ENTER ?? FOR MENU OR NEW DATA ID

24

Enter: 0 to set up for FORCE plots
1 to set up for PRESSURE plots
2 to START plotting after set up
3 to RESET plotting TASK
4 to KILL real time plot task
\$\$ to exit

0

RTPLT is running in system

Enter: 1 to use all present parameters
2 to read scales from terminal
3 to read scales from another device
4 to store setup information
5 to retrieve setup information
6 to list setup information
7 to exit

2

Is this to be a SPECIAL plot
requiring additional entries at the PLOTTING TERMINAL
(Y OR N) ?

NOTE: If the response is 'Y', an additional menu appears on
the GraphOn plotting terminal. (See menu for GraphOn plotting
terminal on page 58).

N

Enter no. of pages

1

Enter no. of plots for page 1

1

Enter plot position for plot 1 (See pages 71-72 for plot positions)

(0)

1

Enter abscissa name for plot 1

()

ALPHA

Enter abscissa MIN, MAX, and DELX

(.0000 .0000 .0000)

-30 30 5

Enter ordinate name

()

CL1.S

Enter ordinate MIN, MAX and DELY

(.0000 .0000 .0000)

-20 20 5

Identifier 24 - Continued

Enter: 0 to set up for FORCE plots
1 to set up for PRESSURE plots
2 to START plotting after set up
3 to RESET plotting TASK
4 to KILL real time plot task
\$\$ to exit

2

RTPLT is running in system

Enter: 0 to set up for FORCE plots
1 to set up for PRESSURE plots
2 to START plotting after set up
3 to RESET plotting TASK
4 to KILL real time plot task
\$\$ to exit

\$\$

TEST 314 RUN 0 LAST POINT 0 ID 24

ENTER ?? FOR MENU OR NEW DATA ID

TEST 300 RUN 200 LAST POINT 19 ID 0

ENTER ?? FOR MENU OR NEW DATA ID

24

Enter: 0 to set up for FORCE plots
1 to set up for PRESSURE plots
2 to START plotting after set up
3 to RESET plotting TASK
4 to KILL real time plot task
\$\$ to exit

1

RTPLT is running in system

Enter: 1 to use all present parameters
2 to read scales from terminal
3 to read scales from another device
4 to store setup information
5 to retrieve setup information
6 to list setup information
7 to exit

2

Is this to be a POLAR plot? (Y or N)

Y

Is this to be a SPECIAL plot
requiring additional entries at the PLOTTING TERMINAL
(Y OR N)?

N

Enter no. of pages

1

Enter no. of plots for page 1

1

Enter plot position for plot 1

(0)

1

Identifier 24 - Continued

Enter abscissa name for plot 1

()

THETA

Enter polar angle MIN, MAX, and DELTA

(.0000 .0000 .0000)

0 360 30

Enter ordinate name

()

DP

Enter ordinate MIN, MAX and DELY

(.0000 .0000 .0000)

-15 15 5

Enter PFACTR for data

(1.000)

Enter range of orifices to be plotted

1 30

Enter: 0 to set up for FORCE plots
1 to set up for PRESSURE plots
2 to START plotting after set up
3 to RESET plotting TASK
4 to KILL real time plot task
\$\$ to exit

2

RTPLT is running in system

Enter: 0 to set up for FORCE plots
1 to set up for PRESSURE plots
2 to START plotting after set up
3 to RESET plotting TASK
4 to KILL real time plot task
\$\$ to exit

\$\$

MENU FROM GRAPHON PLOTTING TERMINAL

Enter: 1 - To plot run(s) from data base
2 - To plot data from other source
3 - To RETAIN multiple plots
4 - To override specialty plots
\$\$ - To start plotting

An explanation of the possible options follows:

- 1 - allows the user to plot a past run in addition to the current run.
- 2 - allows the user to possibly plot theoretical data or data from another test as a comparison with the current run.
- 3 - allows several runs to be plotted on screen in real-time.
- 4 - allows the user to change his mind.

SETTING UP TUNNEL DISPLAYS
(Identifier 25)

25

Enter: 1 to list LED names
2 to change LED names
3 to delete LED names
4 to store LED setup
5 to retrieve LED setup
CR to exit

1

LED No.	PARAMETER	TEST No.
---------	-----------	----------

Enter: 1 to list LED names
2 to change LED names
3 to delete LED names
4 to store LED setup
5 to retrieve LED setup
CR to exit

2

Enter LED display no. - or 0 to end

1

Enter name

ALPHA

Enter LED display no. - or 0 to end

Enter: 1 to list LED names
2 to change LED names
3 to delete LED names
4 to store LED setup
5 to retrieve LED setup
CR to exit

1

LED No.	PARAMETER	TEST No.
1	ALPHA	301

Enter: 1 to list LED names
2 to change LED names
3 to delete LED names
4 to store LED setup
5 to retrieve LED setup
CR to exit

TEST 301 RUN 276 LAST POINT 13 ID 24

ENTER ?? FOR MENU OR NEW DATA ID

Tunnel parameters are displayed, up to six per screen, on designated 14 in. ISC terminals in the control room. Unlike the OAP real-time display pages, these real-time displays are name driven.

REMOTE DATA TAKING OPTION
(Identifier 26)

TEST 361 RUN 3 LAST POINT 0 ID 25

ENTER ?? FOR MENU OR NEW DATA ID

26

This option causes DTALK, a task which establishes the remote data taking capability, to be activated on the system. This option is utilized most frequently with the laser velocimeter tests conducted in the facility. It allows the investigator to trigger data acquisition from a source other than the OAP terminal. DTALK will queue a read to an asynchronous terminal port. When a carriage return is received on the port, it will return specified test parameters. When a 'D' is received, it will trigger a data point. When an 'X' is received, it will exit the system and return control of data point taking to the OAP terminal. The asynchronous port may be connected to either another system terminal or another computer.

PLAYBACK TAPE
(Identifier 99)

TEST 275 RUN 1 LAST POINT 0 ID 0

ENTER ?? FOR MENU OR NEW DATA ID

99

Do you really want to read the data tape? (Y/N)

Y

Put end of file on tape and position it.

READY?

Y

Do you want to use setup information on tape? (Y/N)

N

The selection of this option causes a raw data tape to be used as input for recalculating previously computed wind tunnel data. A negative response causes setup information presently in the particular TNNN task to be used instead of that on tape. This setup information includes title, sensitivity constants, zeroes, USERP information, offsets, indexes, names, balance parameters, balance deck, and several others which are necessary in recalculating data or just restoring previously calculated data back on the data base. When data is being recalculated, previously stored data should be removed from the database. Otherwise, the new data will be added to that already on the disk.

TEST 301 RUN 276 LAST POINT 13 ID 24

ENTER ?? FOR MENU OR NEW DATA ID

EX

Selection of this option causes the TNNN task to terminate execution and returns the operator to the OAP environment.

8.0 QCODE OPTION

QCODE options are given below.

- 0 **STATIC TEST**
 $V_{\infty} = 0$; $Q_{\infty} = 0$.
- 1 **PITOT***
 Dynamic pressure is computed from the QI mensor pressure gauge by using the equation, $QI = \text{Reading} * \text{Sensitivity}$. A correction factor is then applied to QI so that the dynamic pressure becomes the equation, $Q = QI * K_T$ and K_T is defined according to the tunnel configuration.
- 2 **CLOSED TEST SECTION**
 $K_T = 1.1496$
- 3 **CLOSED TEST SECTION WITH B.L. SUCTION**
 $K_T = 1.1266$
- 4 **OPEN TEST SECTION**
 $K_T = 1.1425$
- 5 **OPEN TEST SECTION WITH B.L. SUCTION**
 $K_T = 1.1334$
- 6 **OPEN TEST SECTION WITH ACOUSTIC PANELS**
 $K_T = 1.1952$

***NOTE:** If Pitot calculation is desired, the following items apply:

- a. Pitot-static probe must be installed in the test section.
- b. Mensor pressure gauge marked QI must be attached physically to the Pitot-static probe.

9.0 SETTING MODEL HEIGHT

Model height is defined to be HGT in the 14- by 22- Foot Subsonic Tunnel. A number of factors need to be considered before this calculation is performed. The two channels used as input for the height calculation have specific names that must be used since the application software cues on them. The names are ELEV, which is digital and always assigned to channel 109, and PITCHM, which is also digital and assigned to channel 108. ELEV is the elevation above the tunnel floor of the pitch head pivot point, measured in inches. PITCHM is the mast pitch angle, measured in degrees, where the angle is positive with the mast pitched back and zero when vertical. The proper sting code, SCODE, must first be determined. This code indicates which support system is being used. It is important that the correct information be provided to the facility engineer and the data reduction group since the constant for the elevation, ELEV, is directly related to the model support system being used. When using the vertical air strut, PITCHM is not measured and therefore not in the channel setup. In order to provide as much detail as possible, the following pages (pages 63-66) are devoted exclusively to the proper setup procedure for sting-mounted models, models using the vertical air strut, and models using the roll sting. Drawings are included to further enhance the visual concept necessary to measure HGT accurately.

***NOTE:** If SCODE is left at 0, HGT will be set to 0.0 by the application software.

9.1 Height Set Up Procedure for Sting-Mounted Models

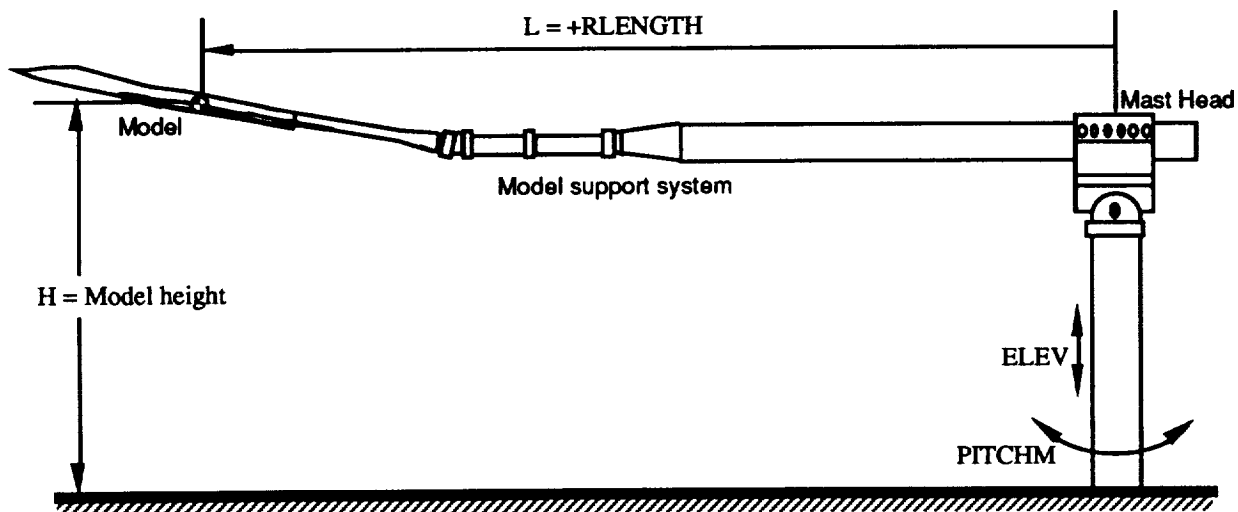

$$\text{HGT} = 87.0 + (\text{ELEV} - 87.0) * \text{COS} (\text{PITCHM}) + \text{RLENGTH} * \text{SIN} (\text{PITCHM})$$

where: HGT = model height at the reference point, in.
 ELEV = elevation above the tunnel floor of the pitch head pivot point, in
 RLENGTH = horiz. distance from model ref. point to pitch head pivot point, in.
 PITCHM = mast pitch angle (+ with mast pitched back, 0.0 vertical), deg.

The above equation is used with a SCODE = 1, refer to Test Engineer's Manual for further detail.

1. Place an inclinometer on the mast head and set mast vertical. Mast height is not critical as long as the model height has sufficient room to clear any obstructions.
2. Measure the horizontal distance from the center of the mast to the model height reference point, (model reference center, bottom of landing gear, wing tip, etc.) and note this value as L in inches.
3. Measure the vertical distance from the model height reference point to the floor, note this value as H in inches.
4. At the OAP terminal, in option 10 of the TXXX task, enter the values for L in the parameter RLENGTH.
5. At the data display pages, look at page 23 (digital channel raw output). Record the counts for ELEV (channel 109) and PITCHM (channel 108).
6. In option 12, in ELEV channel, enter the correct value for the CONSTANT depending on the model cart used. See table below. Enter the digital channel counts for ELEV in step 5 for ZERO and value for H in step 3 for the OFFSET.

Model Cart 1 (mechanical strut)	CONSTANT=	-0.0031122
Model Cart 2 (hydraulic strut)	CONSTANT=	0.01685
Model Cart 4 (mechanical strut)	CONSTANT=	0.00099039
7. In option 12, modify the PITCHM channel. Check and make sure the CONSTANT for PITCHM is in place (0.01). Enter the digital counts in step 5 for the ZERO.
8. Take a wind-off zero and check the model height at several heights and pitch angles.

NOTE: ELEV may use either an encoder attached to the mast drive motor or a linear displacement transducer. Whatever instrument is used, the procedure is the same. Make sure the correct instrument is connected to the MODCOMP.

9.2 Height Set Up Procedure for the Vertical Air Strut

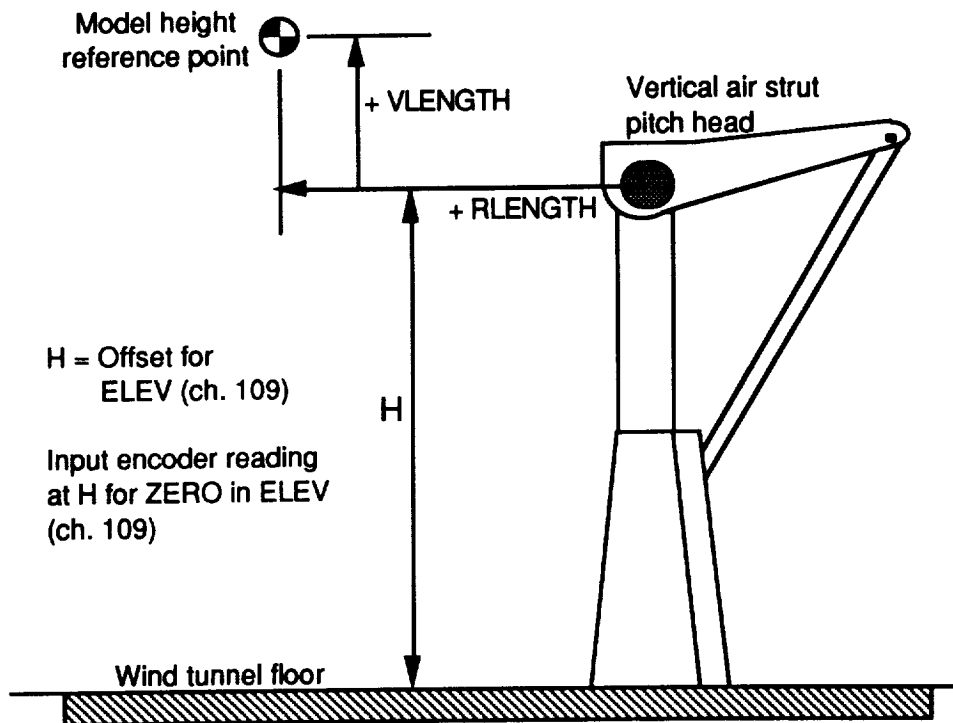

$$HGT = ELEV + RLENGTH * \sin(\text{ALPHA}) + VLENGTH * \cos(\text{ALPHA})$$

where: HGT = model height at the reference point, in.
 ELEV = elevation above the tunnel floor of the pitch head pivot point, in
 RLENGTH = horiz. distance from model ref. point to pitch head pivot point, in.
 VLENGTH = vertical distance from ref. point to pivot point, in.
 ALPHA = angle-of-attack, deg.

The above equation is used with a SCODE = 3, refer to Test Engineer's Manual for further detail.

1. With the model set at zero pitch or angle-of-attack, measure the vertical distance from the floor to pivot point of the pitch head (see sketch). This distance is H.
2. In addition, measure the vertical distance from the pitch head pivot point to the model height reference center (VLENGTH) and the horizontal distance from pivot point to model reference point (RLENGTH).
3. At an ISC terminal or equivalent, record the encoder reading for ELEV corresponding to distance H.
4. At the OAP terminal, in option 10 of the TXXX task, enter the values for VLENGTH and RLENGTH. Positive convention as shown on the sketch above. Also, enter 3 (for strut) for the SCODE.

5. In option 12, in channel 109 (ELEV), enter the value of -0.01468 for the CONSTANT, the encoder reading for ZERO and value for H for the OFFSET.
6. Take a wind-off zero and check the model height at several heights and pitch angles.

9.3 Model Height and Attitude with the Roll Sting

When using the roll sting, it becomes necessary to contend with some additional requirements to insure the proper calculation of not only HGT but the angle of attack (α) and the angle of sideslip (β) also. The roll sting incorporates the effect of the three joints on the angles used in determining the attitude parameters. The joints are defined as JT1, the rotation angle of the front joint; JT2, the rotation angle of the middle joint; and JT3, the rotation angle of the rear joint. These rotations are all measured in degrees and are all digital channels. The zero joint positions are assumed to be with zero roll on the front sting and the "U" down. The application software applies corrections to the model angle of yaw, the model angle of roll, and the model pitch angle based on these readings from the joint channels. Since α and β use these three angles, it becomes necessary to take proper care to enter the correct input. The software requires that the ZERO for each joint be input through option 12 of the TXXX task. The correct ZEROs are 41,000, 50,000, and 59,000 counts for JT1, JT2, and JT3 respectively and the equations are:

$$\begin{aligned} \text{JT1} &= (\text{Reading} - 41000.) * .01 \\ \text{JT2} &= (\text{Reading} - 50000.) * .01 \\ \text{JT3} &= (\text{Reading} - 59000.) * .01 \end{aligned}$$

$$\text{HGT} = 87.0 + (\text{ELEV} - 87.0) * \text{COS}(\text{PITCHM}) + \text{RLENGTH} * \text{SIN}(\text{PITCHM})$$

where: HGT = model height at the reference point, in.
 ELEV = elevation above the tunnel floor of the pitch head pivot point, in
 RLENGTH = horiz. distance from model ref. point to pitch head pivot point, in.
 PITCHM = mast pitch angle (+ with mast pitched back, 0.0 vertical), deg.

The SCODE is set to 2 to reflect the use of the roll sting.

*NOTE: For model cart 4, the roll sting, there is no PITCHM in the channel setup. Therefore PITCHM is set to 0.0 for use in calculating the parameter HGT.

10.0 STAND-ALONE PROGRAMS

10.1 LSQ

This program applies a 1 to 9th order polynomial curve fit to data input via a BIOS file or a DBxxx database file.

\$JOB

\$EXE LSQ,XLM

\$ASSL ONO

Options:

- 1 to use test data on data base
- 2 to use data in common
- 3 for device or disk file input
- RETURN to stop

1

Enter database name or test number
273

Enter abscissa name (POINT) (X-AXIS-Calibrating channel parameter name)
PST3

Enter ordinate name (XNPUTI) (Y-AXIS-Applied known load)

Enter run number
28

1	.17592	.00000
2	.58175	100.00
3	.99058	200.00
4	1.4014	300.00
5	1.8082	400.00
6	2.2171	500.00
7	1.8082	400.00
8	.99258	200.00
9	.17592	.00000

Enter void point number

Enter modified data (INDEX, X, Y)

Enter scale factors or SIN for asin fit

Enter NPOW
1

Enter TITLE
PST3 CALIB.

(PLOTS CALIBRATION ON GRAPHON PLOTTING TERMINAL)
(SAMPLE OF CALIBRATION PLOT, SEE FIGURE 1 ON PAGE 67)

Options:

- 1 to use test data on data base
- 2 to use data in common
- 3 for device or disk file input
- RETURN to stop

3

Enter data input device
<c/r> *

Enter data (\$\$ to stop)

0 0
2 4
3 9
5.1 26.01
6.2 38.44

\$\$

Enter abscissa name

XXX

Enter ordinate name

YY

1	.00000	.00000
2	2.0000	4.0000
3	3.0000	9.0000
4	5.1000	26.010
5	6.2000	38.440

Enter void point number

Enter modified data (INDEX,X,Y)

Enter scale factors or SIN for asin fit

Enter NPOW

2

Enter TITLE

EXAMPLE

Options:

- 1 to use test data on data base
- 2 to use data in common
- 3 for device or disk file input
- <RETURN> to stop

***NOTE:** A c/r indicates that the input device is the terminal and input is expected from the keyboard. Other input devices would be a specific BIOS file name provided by the data reduction group.

PSL CALIB.

RUN = 21

6/15/83

(0) = 1.0077

(1) = -4.8634

DEV. = .21195

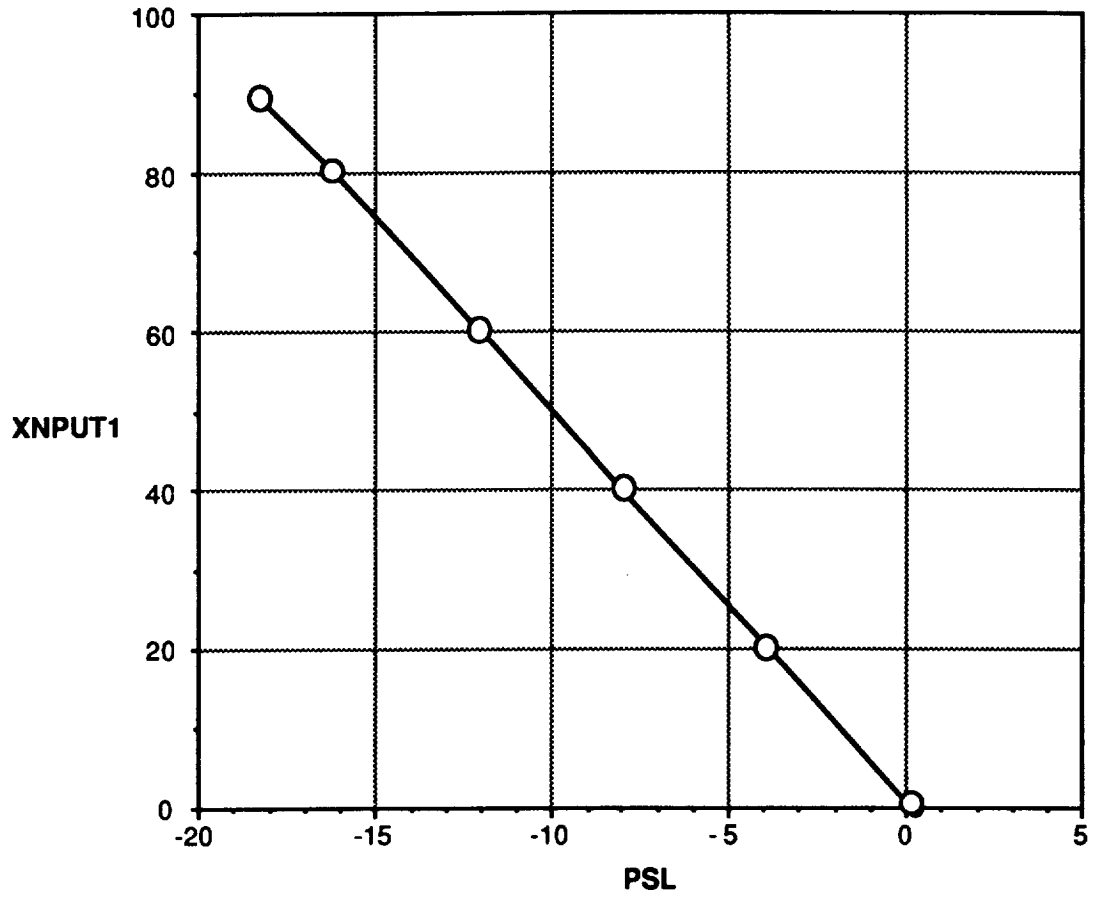

(0) = OFFSET (data type dependent)

(1) = SENSITIVITY CONSTANT

Figure 1. Sample of Calibration Plot

PSL CALIB.

RUN = 21
CON (0) = 1.00772
CON (1) = -4.86337

RMS DEVIATION = .21195

PT	PSL	XNPUT1	P	ERROR
1	.16792	.00000	.19108	-.19108
2	-3.8821	20.000	19.888	.11236
3	-8.0080	40.000	39.954	.46371E-01
4	-12.050	60.000	59.806	.19426
5	-16.208	80.000	79.833	.16718
6	-18.391	90.000	90.449	-.44916
7	-12.090	60.000	59.806	.19426
8	.19190	.00000	74416E-01	-.74416E-01

Sample of Line Printer Output

Below is a brief description of what each heading in the printout means.

PSL - the analog or digital output of a channel (in this case, PSL) due to the known load.

XNPUT1 - known load (entered from keyboard through option 6 and/or option 2).

P - values returned as a result of using the curvefit constant(s) and the offset.

ERROR - difference in XNPUT1 and P.

10.2 PLTFDA

This program can be used to plot data stored on the DBxxx database file. A copy of the plot will go out to the GraphOn designated for plotting only. A hard copy is obtained via the Laser printer. These hard copies are about normal page size. The engineer is responsible for running this program.

```
$JOB
$EXE PLTFDA,XLM
$ASSLONO
```

Enter database file or test number

273

Enter: 0 to use present parameters with calculated scales
1 to use all present parameters
2 to read scales from terminal
3 to read scales from device
RETURN to exit

1

Enter run numbers (5 max.)
0 0 0 0 0

Do you want a hard copy? (Y/N)

N

Enter: 0 to use present parameters with calculated scales
1 to use all present parameters
2 to read scales from terminal
3 to read scales from device
RETURN to exit

2

Enter run numbers (5 max.)
0 0 0 0 0

Enter number of plots

(1)

Enter name of sorting parameter

()

Enter plot position for plot 1

(1)

Enter abscissa name for plot 1

()

Enter abscissa MIN, MAX, and DELX
(.0000 .0000 .0000)

Enter ordinate name

()

Enter ordinate MIN, MAX and DELY
(.0000 .0000 .0000)

PLOT POSITION (See Figure 2, pages 70-71)

1 = Full

2 = Half Top

3 = Half Bottom

4 = One Quarter Left Top

5 = One Quarter Right Top

6 = One Quarter Left Bottom

7 = One Quarter Right Bottom

8 = One Sixth Left Top

9 = One Sixth Top Middle

10 = One Sixth Right Top

11 = One Sixth Left Bottom

12 = One Sixth Bottom Middle

13 = One Sixth Bottom Right

14 = Left Half

15 = Right Half

Do you want a hard copy? (Y/N)

***NOTE:** If Option is 3 IS SELECTED, the operator is prompted to input the BIOS file name.

Parameters on the BIOS file are free format and are created by data reduction personnel. Below is a sample of what a BIOS file should look like.

```
NPAGES
NPLOTS
NIL          (always a 0)
NSORT
IPLOT(1)
NX(1)
AXMIN(1),AXMAX(1),ADELX(1)
NY(1)
AYMIN(1),AYMAX(1),ADELY(1)
.
.
.
NX(NPLOTS)
AXMIN(NPLOTS),AXMAX(NPLOTS),ADELX(NPLOTS)
NY(NPLOTS)
AYMIN(NPLOTS),AYMAX(NPLOTS),ADELY(NPLOTS)
```

Parameters are defined as follows:

NPAGES	-	NUMBER OF PAGES
NPLOTS	-	NUMBER OF PLOTS PER PAGE
NIL	-	SOMETHING TO MAKE COMPILER HAPPY
NSORT	-	NAME OF SORTING PARAMETER
IPLOT(1:6)	-	PLOT POSITION
NX(1:6)	-	NAME OF ABSCISSA VARIABLE
AXMIN(1:6)	-	ABSCISSA MIN
AXMAX(1:6)	-	ABSCISSA MAX
ADELX(1:6)	-	ABSCISSA MAJOR TICK MARK
NY(1:6)	-	NAME OF ORDINATE VARIABLE
AYMIN(1:6)	-	ORDINATE MIN
AYMAX(1:6)	-	ORDINATE MAX
ADELY(1:6)	-	ORDINATE MAJOR TICK MARK

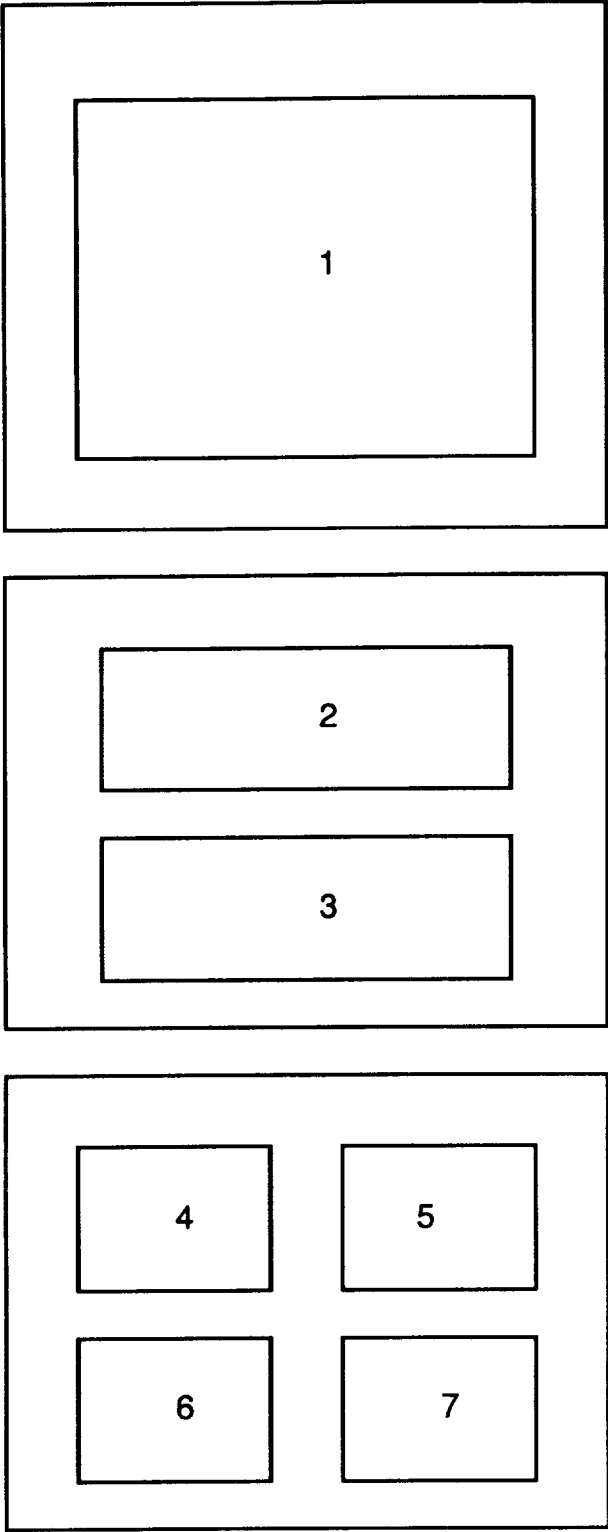

Figure 2. Plot Position Indexes (Sheet 1 of 2)

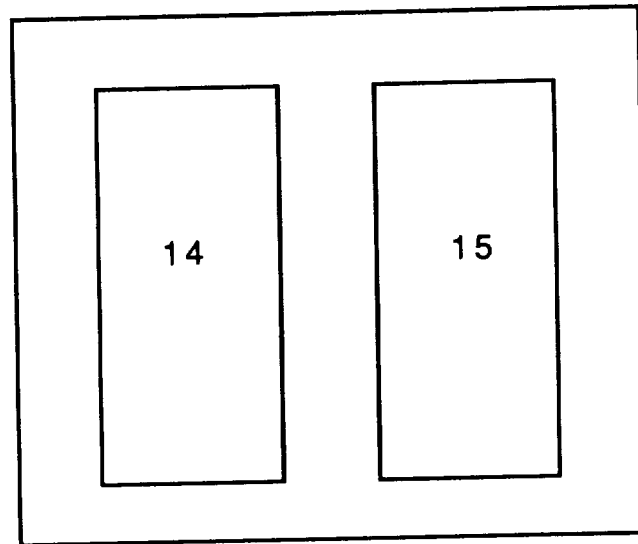
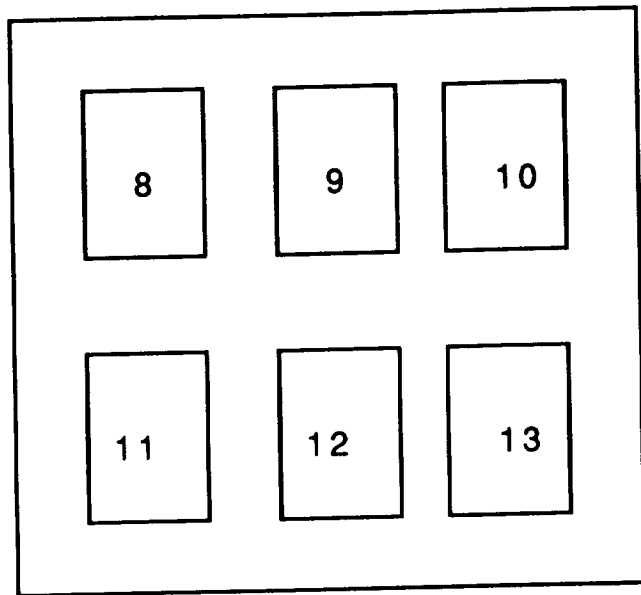

Figure2. (Continued)

(Sheet 2 of 2)

Enter: 0 to use present parameters with calculated scales
 1 to use all present parameters
 2 to read scales from terminal
 3 to read scales from device
 RETURN to exit

10.3 PLTPD

This program allows the user to plot pressure data stored on the DBxxxP database file in very much the same way as the PLTFDA program plots force data.

\$JOB
 \$EXE PLTPD,XLM
 \$ASS LO NO

Enter database file name or test number
 314

Enter: 0 to use present parameters with calc. scales
 1 to use all present parameters
 2 to read scales from terminal
 3 to read scales from device
 <RETURN> to exit

2
 Enter run numbers (5 max.) *
 0 0 0 0 0
 100
 Enter point numbers (5 max., one for each run)
 0 0 0 0 0

***NOTE:** For every point requested, the corresponding run number must be input. For example, if the desire is to plot run 100, points 2-4, then run 100 must be entered 3 times.

2
 Enter no. of plots
 (0)
 1
 Enter PFACTR (PFACTR is scale factor for plotting --- 1 for PSI and 144 for PSF)
 (1.0000)

Is this a polar plot?
 N

Enter plot position for plot 1 (See pages 70-71 for plot position)
 (0)

1
 Enter abscissa name for plot 1
 ()
 XLOC

Enter abscissa MIN,MAX,and DELX
 (.0000 .0000 .0000)
 0. 300. 50.

Enter ordinate name
 ()
 DP

Enter ordinate MIN,MAX and DELY
 (.0000 .0000 .0000)
 -10. 0. 1.

Enter STRIP # or plotting range
 (0 through 0)
 1 20

AVAILABLE OPTIONS ARE:

- 0 - PLOT DP
- 1 - PLOT ABSOLUTE PRESSURE
- 2 - PLOT CP
- 3 - EXIT

WHICH OPTION DO YOU WANT?

0

INDX	1	XLOC	.00000	YDATA	-3.9889
INDX	2	XLOC	12.000	YDATA	-3.9705
INDX	3	XLOC	24.000	YDATA	-3.9812
INDX	4	XLOC	48.000	YDATA	-4.8104
INDX	5	XLOC	72.000	YDATA	-5.2819
INDX	6	XLOC	84.000	YDATA	-5.2683
INDX	7	XLOC	132.00	YDATA	-5.8373
INDX	8	XLOC	144.00	YDATA	-5.9840
INDX	9	XLOC	156.00	YDATA	-6.1968
INDX	10	XLOC	168.00	YDATA	-6.0600
INDX	11	XLOC	180.00	YDATA	-6.1739
INDX	12	XLOC	192.00	YDATA	-6.2693
INDX	13	XLOC	204.00	YDATA	-6.1634
INDX	14	XLOC	216.00	YDATA	-6.1745
INDX	15	XLOC	228.00	YDATA	-6.1192
INDX	16	XLOC	240.00	YDATA	-5.9478
INDX	17	XLOC	264.00	YDATA	-5.3390
INDX	18	XLOC	276.00	YDATA	-5.5230
INDX	19	XLOC	288.00	YDATA	-5.0585
INDX	20	XLOC	300.00	YDATA	-5.0955

Do you want a hard copy?

Y

Enter: 0 to use present parameters with calc. scales
 1 to use all present parameters
 2 to read scales from terminal
 3 to read scales from device
 <RETURN> to exit

If option 3 is selected, the operator will be prompted to enter the BIOS file name. Parameters on the file are free format and are created by the data reduction personnel. Below is a sample of what a BIOS file should look like.

```
NPAGES
NLOTS
NIL          (always a 0)
NSORT
IPLOT(1)
NX(1)
AXMIN(1),AXMAX(1),ADELX(1)
NY(1)
AYMIN(1),AYMAX(1),ADELY(1)
PFACTOR(1)
NPUT
IRANGE(1)
```

NX(NPLOTS)
 AXMIN(NPLOTS),AXMAX(NPLOTS),ADELX(NPLOTS)
 NY(NPLOTS)
 AYMIN(NPLOTS),AYMAX(NPLOTS),ADELY(NPLOTS)
 PFACTOR(NPLOTS)
 NPUT
 IRANGE(NPLOTS)

Parameters are defined as follows:

NPAGES	-	NUMBER OF PAGES
NPLOTS	-	NUMBER OF PLOTS PER PAGE
NIL	-	SOMETHING TO MAKE COMPILER HAPPY
NSORT	-	NAME OF SORTING PARAMETER
ILOT(1:6)	-	PLOT POSITION
NX(1:6)	-	NAME OF ABSCISSA VARIABLE
AXMIN(1:6)	-	ABSCISSA MIN
AXMAX(1:6)	-	ABSCISSA MAX
ADELX(1:6)	-	ABSCISSA MAJOR TICK MARK
NY(1:6)	-	NAME OF ORDINATE VARIABLE
AYMIN(1:6)	-	ORDINATE MIN
AYMAX(1:6)	-	ORDINATE MAX
ADELY(1:6)	-	ORDINATE MAJOR TICK MARK
PFACTOR(1:6)	-	PRESSURE CORRECTION FACTOR
NPUT	-	ASCII RESPONSE (Y/N) TO 'IS THIS A POLAR PLOT?'
IRANGE(1:2,1:6)	-	STRIP # OR ACTUAL RANGE *

* If strip number is preferred, the program expects the second number to be a 0. If orifice range is preferred, the program expects the first and last values of the desired range. For example, to plot strip #1 with 20 ports, you may choose to plot the whole strip. In that case, simply input "1 0". To plot the exact same information using the orifice ranges, input "1 20".

10.4 TCLEAR

This is a program that must be run to reset conditions in memory after the TNNN task has been unnaturally terminated. This may be the result of TNNN aborting or queing due to software problems, hardware problems, or operator errors.

Type in EXE TCLEAR,XLM and respond to the question.

Then type in JOB and try bringing up the task again through OAP menu.

10.5 DBASE

This program is used to query the force data base. It allows the user to edit data, list data, copy data to an ASIF file, copy data from an ASIF file to a data base and create a SIF file suitable for Bruce Graham's DAS plot program. The test engineer is responsible for running this program.

```
$JOB
$EXE DBASE,XLM
$ASSLONO
```

Enter database file name or test number
263

Available options are:

- 1 - prints single data parameters
- 2 - deletes runs or single points
- 3 - prints a run summary
- 4 - copies ASIFT file to data base
- 5 - copies data base to ASIFT file
- 6 - changes parameter name
- 7 - lists names
- 8 - lists runs
- 9 - create SIF file for DAS program
- 0 - exits

***NOTE:** Technicians should not be concerned with options 2, 4, 5, and 6. If you have any questions, contact the test engineer or data reduction personnel.

Which option do you want?

7

Parameter Index Table

1	TEST	2	RUN	3	POINT	4	ID	5	QCODE
6	MCODE	7	NBAL	8	SAMPLES	9	WCODE	10	CONF
11	TAPE	12	DBASE	13	PCODE	14	LIST	15	MPORT
16	IPOINT	17	IESP	18	SCODE	19	DEBUG	20	FMCODE
21	RLENGTH	22	VLENGTH	26	YRMODE	27	HRMNSC	28	XNPUT1
29	XNPUT2	30	XNPUT3	95	ESPTMP1	96	ESPTMP1	97	ESPTMP3
98	VOLT	159	Q	160	VEL	161	PTOT	162	PSTAT
163	RN	164	RHO	165	ALPHA	166	BETA	167	THETA
168	PSI	169	PHI	170	HGT				

Available options are:

- 1 - print single data parameters
- 2 - deletes runs or single points
- 3 - print a run summary
- 4 - copies ASIFT file to data base
- 5 - copies data base to ASIFT file
- 6 - changes parameter name
- 7 - lists names
- 8 - lists runs
- 9 - create SIF file for DAS program
- 0 - exit

Which option do you want?

OPTION 1 - prints to the terminal point and corresponding values for a selected parameter.

OPTION 2 - causes data points or entire runs to be permanently deleted from the database.

OPTION 3- prints a run summary (eight parameters per page including point). The option exists to enter the names interactively or by reading a BIOS file. A BIOS file is a basic input-output system file designated by a 3-character name. To create a BIOS file, contact a data reduction person.

OPTION 4 - allows one to restore data saved on a tape or a scratch file onto the database.

OPTION 5 - allows one to save the contents of the database to a tape or scratch file.

OPTION 6 - allows one to change parameter names by using the old name or the database index number.

OPTION 7 - lists all of the database's parameter names.

OPTION 8 - lists all of the runs on the database.

OPTION 9 - prompts the operator to enter a BIOS file name on which data formatted for plotting program DAS will be written. This allows the engineer or data reduction person to then FTP the database runs directly to a workstation.

Options 2, 4, 5, and 6 are the exclusive responsibility of the data reduction personnel.

10.6 DBASEP

This program is used to query a pressure data base. It allows the user to edit data, list data, copy data to an ASIF file, and copy data from an ASIF file to a data base. The test engineer is responsible for running this program. It should be noted that the pressure database stores all pressures in Δ ps only. Since the 30 word array of action parameters (TEST, RUN, POINT, etc), the six tunnel parameters, and the support parameters are also stored for each data point, it is relatively easy to convert Δ ps into Cps or absolute pressures.

```
$JOB
$EXE DBASEP,XLM
$ASS LO NO
```

```
Enter database file name or test number
273
```

Available options are:

- 1 - deletes runs or single points
- 2 - prints a run summary
- 3 - copies ASIFT file to data base
- 4 - copies data base to ASIFT file
- 5 - lists runs
- 6 - create SIF file for DAS program
- 0 - exit

Which option do you want?

2

AVAILABLE OPTIONS ARE:

- 0 - PRINTS DP
- 1 - PRINTS ABSOLUTE PRESSURE
- 2 - PRINTS CP

WHICH OPTION DO YOU WANT?

OPTION 1 - causes data points or entire runs to be permanently deleted form the database.

OPTION 2 - allows one to print Δ Ps, absolute pressures, or pressure coefficients.

OPTION 3 - allows one to restore data saved on a tape or a scratch file onto the database.

OPTION 4 - allows one to save the contents of the database to a tape or scratch file.

OPTION 5 - lists all the runs on the database.

OPTION 6 - prompts the operator to enter a BIOS file name on which data formatted for plotting program DAS will be written. This allows the engineer or data reduction person to then FTP the database runs directly to a workstation. The user will be prompted to enter a BIOS file name for the pressures (*i.e.* ADF) and a BIOS file name for the strips (*i.e.* "ADE").

References

1. Users' Manual for the Langley Research Center 14- X 22- Foot Wind Tunnel Facility Data Acquisition System, document number SD63128-129R4-D3.
2. 14- X 22-Foot Subsonic Tunnel Test Engineer's Manual, document number SD63108-129R2-D1.
3. Wyle NEFF 300 Hardware Manual, document number HD63231-312R0-D8.
4. Operator's Guide for the 14- X 22-Foot Static System Data Acquisition System Operating Acquisition Program (OAP), document number SD63102-333R1-D6.

APPENDIX A
SAMPLE TEST SETUP SHEETS

The static data acquisition system requires certain information for data reduction and hardware setup purposes in the tunnel, rotor test cell, or the model preparation area. It is important that this information be as complete as possible prior to the start of the test. The next several pages will instruct one how to complete a TIF (Test Information Form) properly.

GENERAL INFORMATION (Pg. 81)
MODEL ASSEMBLY (Pg. 81)
WIND TUNNEL PARAMETERS (Pg. 82)
ENGINE SIMULATION (Pg. 82)
INSTRUMENTATION USED IN TEST (Pg. 83)
BALANCE INFORMATION (Pg. 83)
DATA ACQUISITION (Pg. 83)
DATA REDUCTION (Pg. 84)
DATA DISPLAY (Pg. 84)
WORK REQUIRED (Pg. 84)
TIF 1 - TORQUE VALUES (Pg. 85)
TIF 2 - HIGH PRESSURE AIR (Pg. 85)
TIF 3 - ESP MODULES (Pg. 85)
TIF 4 - ANALOG CHANNEL SETUP (Pg. 86)
TIF 5 - DIGITAL CHANNEL SETUP (Pg. 86)
TIF 6 - DATA DISPLAY PAGE SETUP (Pg.87)
TIF 7 - TUNNEL DISPLAY SETUP (Pg. 87)
TIF 8 - ON-LINE PLOTTING SETUP (Pg. 88)

14- BY 22-FOOT SUBSONIC TUNNEL AND FACILITIES TEST INFORMATION FORM INSTRUCTIONS

The Test Information Form (TIF) is used to help the Facility Manager, Data Reduction Personnel, and Tunnel Technicians set-up for your test. Please read the first three items concerning returning the form to the Facility Manager, photograph of the model, and dismantling of your model after the test. When the TIF is completed, please return it to the Facility Manager for review and he will get the appropriate signatures.

Prior to completing this form, several pre-test meeting should have been scheduled to discuss wind tunnel schedules, data reduction, instrumentation, model support, etc. The information from these meetings will help you complete this form.

Check the appropriate boxes to indicate which TIF forms were used.

I. GENERAL INFORMATION

- A. **Test Title** - give a brief phrase that identifies your test.
- B. **Project Engineer** - the name of the person that is primarily responsible for this particular test (not the people on each shift) and the telephone number to reach that person when questions arise.
- C. **Test Engineers** - Names of engineers that will be staffing the shifts.
- D. **Test Number and Job Order** - test number to identify your test can be obtained from the Data Reduction Group. The Job Order is needed to charge certain tasks, such as balance spans, instrumentation support, etc.
- E. **Security Classification** - classification of the model to be tested and the data from it: unclassified (UNCL), confidential (CONF), proprietary (PROP), secret (SCRT), etc.
- F. **Brief Description** - give a brief description of the test and its objectives.

II. MODEL ASSEMBLY

- A. **Model cart and support system** - specify the stings, knuckles, struts, interfaces, offsets, balance blocks, etc. to be incorporated in the model support system and the model cart that it will be mounted. The Model Support Hardware Guide may help you chose the correct items for the model support system that will meet your needs.
- B. **Pre-test assembly**
 - 1. **Location** - test site location to be used or specify assembly area. Is the model to be fully or partially assembled?
 - 2. **Pre-test activities** - check the appropriate category, if any or specify what needs to be done.
- C. **Model transport to tunnel** - check either box to indicate how the model will be moved, on the model cart or separately by other means.
- D. **Model preparation**
 - 1. **Fouling circuit** - check the appropriate box; if a fouling circuit is needed, please specify location.
 - 2. **Transition grit** - if transition grit is used, please specify the grit size and location on the model.
- E. **Torque values** - torque values can be specified on Form TIF 1 or on the model drawings. The project engineer is ultimately responsible for obtaining the correct torque values for the model.

III. WIND TUNNEL PARAMETERS

- A. **Test section configuration** - specify how the test section is to be configured: closed, slotted, open, partially open with either wall(s) or ceiling down, etc.
- B. **Test dynamic pressure or velocity range** - specify either dynamic pressure or velocity range by checking corresponding box. The correct units of the range is helpful.
- C. **Test section model cart configuration** - specify the model cart arrangement for the front and aft bays. There are 4 model carts and 2 floor carts available (see NASA TP 3008 for specifics).
- D. **Model attitude range** - specify the pitch, yaw, and roll range in degrees for your test.
- E. **Floor boundary layer exhaustor** - the exhaustor should be used to reduce the boundary layer height, such as during ground effects testing.
- F. **Model height**
 - 1. **Minimum height** - specify the minimum model height to be tested. If the model will not be tested in ground effect please write wind tunnel centerline or specify height above the floor. Check box if a limit switch is needed to prevent model contact with the floor.
 - 2. **Model height reference point** - give the location of the model height reference, such as left wing trailing-edge wing tip, lower corner of nozzle, etc.

IV. ENGINE SIMULATION

- A. **Low pressure air** - check the appropriate box if low pressure (house air) will be used (max. pressure is about 100 psi).
- B. **High pressure air** - if high pressure air is used, Form TIF 2 must be completed to specify pressure transducer and switch settings to activate the relief valve at the air station.
 - 1. **Air station used** - check the air station to be used. Air Station No. 1 is located below the test section and supplies high pressure air at about 20 to 30 lbs/sec at max. pressure of about 5000 psi. The MPA has two Air Stations, Nos. 2 and 3. No. 3 is connected to Air Station No.1 and uses all its control valves. No. 2 is the older air station and it is capable of about 12 - 15 lbs/sec of air at 1800 psi.
 - 2. **Flowmeters** - refer to the chart below for the correct flowmeter code (FMCODE) or number and its weight flow range. At Air Station No. 2, the flowmeters must be physically changed (flowmeters 1 - 3). At Station 1 and 3, the flowmeters can be changed on-line at the air station controls, from either a low weight flow or a high weight flow (flowmeters 4 - 7). **CAUTION:** If a flowmeter is changed during a middle of a test, Data Reduction personnel must be notified to make flowmeter constant changes.

Flowmeter No.	Est. Weight Flow Range	Air Station No.	Throat Dia., in.
1	0 to 5 lbs/sec	2	.449
2	4 to 10 lbs/sec	2	.795
3	8 to 15 lbs/sec	2	1.249
4	0 to 3 lbs/sec	1 and 3**	.444
5	2 to 8 lbs/sec	1 and 3*	.689
6	5 to 20 lbs/sec	1 and 3*	1.147
7	15 to 30 lbs/sec	1 and 3**	1.402

* Currently installed at Air Station No. 1

** Need to be physically installed to replace current flowmeters

- C. **Motor generator (MG) set** - if electric motors are used to power rotors, propellers, etc., please specify which MG set(s) is (are) to be used. The 240 KVA unit is below the 14 X 22 test section and the two 62.5 KVA units are located at 7 X 10 High Speed Tunnel.

V. **INSTRUMENTATION USED IN THE TEST**

- A. **Number of balances used** - give the number of balances to be used on this test, if any. Also fill out Section VI with more detailed information.
- B. **Number of pressure transducers used** - list the number of individual pressure transducers (not ESP modules) to be used and their pressure range.
- C. **Number of thermocouples used** - list the number of thermocouples needed for the test. This facility usually uses iron-constantan thermocouples.
- D. **Number of ESP modules to be used** - list the total number of ESP modules to be used. Specify the number of ports per module (16, 32, or 48) and their pressure ranges. The system can handle different pressure ranges, but can only handle a single type of module, either 16s, 32s, or 48s. This facility has four 1 psi, twenty 5 psi, and two 45 psi modules. Also, state the print-out format for the ESP pressures, either differential, absolute, or coefficient form. NOTE: please provide the Data Reduction Personnel with pressure strip grouping and fill out Form TIF 3 for ESP hook-up information.
- E. **Others** - list other instrumentation to be used. Any special power requirements, connections, or set-up should be discussed with the Facility Manager.

VI. **BALANCE INFORMATION**

Balance name - list the name of the balance (i.e. 748, 1621B, VST-3, etc.)

Balance type - specify whether the balance is a regular (R) NASA Langley balance or a task balance (T).

X-, Y-, and Z-transfers - list the transfers from the balance reference center to the model reference center, in inches (see Users' Manual for sign convention).

gamma₁, 2, and 3 - list balance rotation angles to align balance axis to model axis in degrees (see Users' Manual for sign convention).

S, c, and b - list reference area, wing chord, and wing span for coefficient calculations. Reference area (wing) is in ft², with wing chord and wing span in inches.

Max. NF, AF, PM, RM, YM, and SF - list maximum loads for each balance component. The max. loads can either be max. working loads or max. calibrated loads.

VII. **DATA ACQUISITION**

- A. **Data acquisition system** - check the boxes that applies to your test; specify other systems to be used and consult the Data Reduction Personnel.
- B. **Number of Data Channels** - list the number of analog and digital channels to be used. Fill out Form TIF 4 for analog channel information and Form TIF 5 for digital channel information.

C. Flow visualization

1. **Recording** - check the boxes which correspond to the methods of recording the flow visualization, either video, photography, or motion picture. Give the location for these cameras.
2. **Flow visualization techniques** - check the boxes that apply to the techniques that will be used on the test and specify other techniques not listed.

VIII. DATA REDUCTION

- A. Consult Data Reduction Personnel about 2 months prior to the test. Let them know how detailed and how complex the test will be. The more detailed and the more complex the software support the longer the lead time needed to prepare your test.
- B. **Data corrections** - check the appropriate boxes that are needed for your data correction. Provide the Data Reduction Personnel with the correction factors. Specify any other data correction methods and provide these methods to the Data Reduction Personnel.

IX. DATA DISPLAY

- A. **Number of display pages** - give the number of data display pages you are planning to use on your test. There is a maximum of 24 data display pages available. About half of the data display pages have already been assigned by the Data Reduction Personnel, such as, analog and digital channel display, balance parameters, and engineering units of the data channels. There are 24 lines per page, but only 23 are available (line 13 is reserved for date and time). Please fill out Form TIF 6 for each data display page.
- B. **Number of tunnel displays** - the tunnel displays will be used by the technicians at each wind tunnel control station. The displays will present the technicians with the needed parameters to run their station. Each display is capable of presenting 4 parameters. Please use Form TIF 7 for tunnel display information.
- C. **On-line plotting** - formerly known as real-time plotting. Please refer to the Users' Manual for set-up and instructions. If this option is used, please check the affirmative box and fill out Form TIF 8.

X. WORK REQUIRED

- A. **Responsible technician(s)** - write the name of the technician that may be the lead on this project. Please check with the Technician Section Head if a lead technician has been assigned to your test.
- B. **Priority** - Check the priority level that you want the work to be accomplished.
- C. **Desired and actual completion date** - state the desired date you want the work to be completed. After the work has been completed, write the actual completion date. This information will help in scheduling tests in the future.
- D. **Work description** - describe the work that is needed from pre-build-up to the end of your test.
- E. **Special equipment required** - specify any special equipment required to set-up your test or to be used in your test.

PLEASE WRITE THE TEST NUMBER AND THE PROJECT ENGINEER ON EACH TIF FORM USED

FORM TIF 1 - Torque Values for Fasteners Used in the Test

If certain fastener torque values are not known, please obtain them from Model Engineering.

Fastener size: list the size of the fastener, such as the diameter of the fastener and the threads per inch.

Number of fasteners: state the number of fasteners of this size that will have a particular torque value.

Torque value: state the torque value for the specified fasteners in either in-lb or ft-lb. Please be consistent throughout the list.

Location: specify the location of the fasteners that will use this particular torque value or state the drawing number that they maybe located.

FORM TIF 2 - High Pressure Air Set-Up for Powered Models

Read the information at the bottom of the form.

Weakest pressure area of the model: state the maximum working pressure of either the model or the sting, which needs to be protected from over-pressure.

Location: give the location of the weakest pressure point in the system.

Transducer value: state the pressure transducer value to activate the relief valve through the air station microprocessor.

Pressure switch setting: state the pressure switch setting to activate the relief valve.

The information above is needed to insure the safety of the model and sting from over-pressure when using either Air Station No. 1 or 3. If Air Station No. 2 is used, just state the weakest pressure area value. Maximum working pressure for Air Station No. 1 and 3 is 5000 psi and for Air Station No. 2 is 1800 psi.

FORM TIF 3 - ESP module information

Use Form TIF 3 for every two ESP modules used. Please state the total number of modules to be used on the test. Also, write the page number on each TIF 3 form used.

Model port number: on most models each pressure port has number assigned to it for identification.

X, Y, and Z locations: specify the coordinates for each pressure port.

Description: add any additional information that may help technicians connect and leak-check the pressure ports.

FORM TIF 4 - Analog Data Channels to be Used On the Test
FORM TIF 5 - Digital Data Channels to be Used On the Test

List all the analog (on Form TIF 4) and digital (on Form TIF 5) channels that will be used on the test. Currently, the data system can accommodate 96 analog and 16 digital channels. Each Model Interface (MIF) rack can patch 48 analog (through NEFF 300) and 8 digital (through Digital Interface Box - DIF) channels to the computer system. Groups of 16 analog channels on a single cable connect the MIF rack to the Patch Cabinet in the control room and then to the NEFF 600. If certain analog channels must be grouped, place the channels so they will be carried on a single 16 channel cable.

Name: 8 character alpha-numeric name that identifies the channel.
Type: there are 5 channel types currently used, as shown below and also above the analog channel information of Form TIF 4. For example most balances are type 1, thermocouples are type 2, and Q-flex are type 4 or 5. Most digital channels are type 2.

Channel types: 0 = R
 1 = $(R - Z) \times C + \text{Offset}$ Where: R = channel reading
 2 = $(R - Z_i) \times C + \text{Offset}$ Z = zero data reading
 3 = $\text{ASIN}((R - Z) \times C) + \text{Offset}$ Z_i = input zero
 4 = $\text{ASIN}((R - Z_i) \times C) + \text{Offset}$ C = sensitivity constant
 5 = $\text{ASIN}((R \times C) + (R \times R \times U)) + \text{Offset}$ U = 2nd order constant in USERP(100)

Units: state the units of the channel (i.e. lb., psf, in-lb, deg.).

Calibration range: if an in-house calibration is needed, please specify the calibration range of the instrument.

Voltage: for analog channel use only. With the NEFF 300, the excitation voltage for instruments are from 2 to 10 volts. Balances will have separate power supplies.

Filter: for analog channel use only. Through the NEFF 600, analog channel filters are available at 1 (default), 10, 100, and 1000 Hz.

Range: for analog channel use only. Each NEFF 600 channel has a programmable gain setting that can be specified. The NEFF 600 has 12 gain selections from ±5 mV to ±10.24 V. The range is set to the expected maximum output of the individual instrumentation. For example: typical NASA Langley balances have a typical 5 to 10 mV output, so the Range can either be set at either ±5 mV or ±10 mV. If the instrumentation output is not specified, the Facility Manager or Data Reductions personnel will assign default range selections of either ±20 mV, ±160 mV, ±1.28 V, or ±10.24 V, depending on the type of instrumentation.

Description: brief description of the instrument or the channel.

MIF: this column may be filled-in by technicians as they are setting the instrumentation. MIF rack channel assignments may differ from MODCOMP assignments.

MODCOMP: Data Reduction personnel may assign channels that may differ from the MIF rack assignments.

FORM TIF 6 - Data Display Page Definition

Data Display pages are available on 19 inch ISC terminals and on some 14 inch ISC terminals. There 24 available pages with 24 display lines per page. Half of the display pages have been allocated by the Data Reductions Group for certain data display. Date, time, and page number has line 13 locked and cannot be used for data display. Please specify the number of Data Display pages to be used on the test. Also write the page number for each Form TIF 6 used on the test.

Name/parameter: 12 character alpha-numeric name of the display line.
Color(Frgrnd & Bkgrnd): Usually the Data Reduction personnel will assign foreground and background colors to each display line. A test engineer may specify foreground and background color for each display line. Available colors are: BLK (black), BLU (blue), WHT (white), CYN (cyan), GRN (green), MAG (magenta), RED (red), and YEL (yellow). RED and YEL should not be used because they indicate parameter limit near or out conditions. Pick foreground (characters) and background (parameter bar) colors so they can easily be seen, such as BLK foreground and WHT background, WHT foreground and BLU background, etc.
Dec. Pt.: indicate the number of decimal places the parameter should have.
Units: specify units for the parameter of that line (i.e. lb., psf, in-lb, deg.).
U. and L. limit: specify upper and lower limits for the parameter in the units specified.

FORM TIF 7 - Tunnel Display Information

The tunnel displays are 14 inch ISC color terminals that will used to by technicians at the various control stations. The technicians will use the displays to set tunnel and model conditions. The ISC terminals will display a maximum of 6 parameters per screen.

Certain displays will be dedicated to certain technician operating stations. Unused displays may be activated to display additional parameters to be viewed by either the test engineers or technicians.
Line 1 to 6: state parameter name for each line in the ISC display. Certain displays have default parameters. The parameter name must be the same ones in the data base.

FORM TIF 8 - On-Line Plotting Information

On-line plotting is available on any given run. The set-up information on this form will help the Data Reductions Group create files with this information. Please refer to the Users' Manual for further information. A maximum of 6 plots can be fitted on a page.

Plots on the page: 6 plots are available on the screen. Give specific plot information on each plot column.

Plot location: Refer to the plot location given at the top of Form TIF 8 and below:

PLOTTING LOCATIONS ON THE SCREEN:

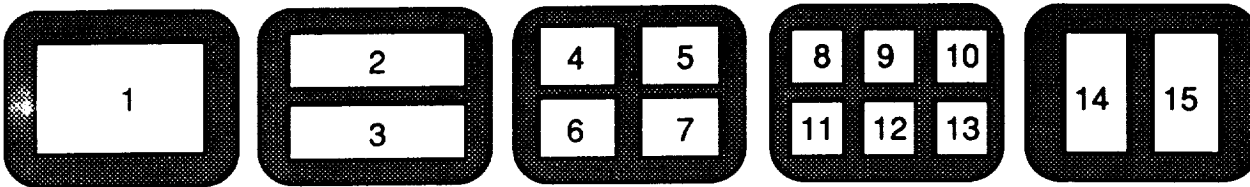

Plot location numbers do not indicate plot number. For example: one plot is to be displayed on the screen; it can be in location 1 (standard), 2, 7, 9, etc. With 2 plots they can be at location 2 and 3, 4 and 6, 9 and 13, etc., but bad locations are 1 and 2, 2 and 5, etc.

Make sure plot locations do not overlap one another.

Abscissa name: x-axis name or label, must match variable name in the data base of the test.

Min. x: minimum x-axis value.

Max. x: maximum x-axis value.

Del. x: x-axis increments.

Ordinate name: y-axis name or label, must match variable name in the data base of the test.

Min. y: minimum y-axis value.

Max. y: maximum y-axis value.

Del. y: y-axis increments.

PFACTOR: used for pressure (ESP module) data, multiplication value applied to the data, such as -1 to "flip the Cp plot", 144 change psf to psi, etc.

Orifice range: used for pressure (ESP module) data, pressure port range or pressure strip number.

APPENDIX B
TEST INFORMATION FORM

14-BY 22-FOOT SUBSONIC TUNNEL AND FACILITIES TEST INFORMATION FORM

THE INFORMATION ON THIS FORM IS USED TO HELP THE DATA REDUCTION PERSONNEL, FACILITY MANAGER, AND TECHNICIANS SET-UP FOR YOUR TEST. IF YOU HAVE ANY QUESTIONS ABOUT THE FORM, PLEASE ASK THE FACILITY MANAGER

1. PLEASE RETURN THE COMPLETED FORM TO THE FACILITY MANAGER. THE FORM WILL BE REVIEWED AND THEN DISTRIBUTED TO THE APPROPRIATE PERSONNEL.
2. PLEASE PROVIDE AT LEAST ONE COLOR PHOTOGRAPH OF THE MODEL TO THE FACILITY MANAGER'S FILES AFTER THE TEST.
3. ON THE LAST SHIFT OF THE TEST, TIME SHOULD BE ALLOTTED TO DISMANTLE THE MODEL AND THE SUPPORT SYSTEM. BE COURTEOUS TO THE NEXT PROJECT ENGINEER; THEIR TEST AND DATA ARE IMPORTANT, TOO.

Approval:	Signature	Date
Facility Safety Head		
Technician Group Leader		
Facility Manager		

TIF forms used (check appropriate boxes): 1 2 3 4 5 6 7 8

I. GENERAL INFORMATION

A. TEST TITLE:

B. PROJECT ENGINEER: PHONE NO.:

C. TEST ENGINEERS:

D. TEST NUMBER: J.O. NUMBER:

E. SECURITY CLASSIFICATION - MODEL: DATA:

F. SCHEDULED TEST DATE:

G. BRIEF DESCRIPTION OF THE TEST:

II. MODEL ASSEMBLY

A. MODEL CART AND SUPPORT SYSTEM (please provide a sketch of model support):

B. PRE-TEST ASSEMBLY:

1. LOCATION: COMPLETE PARTIAL

2. PRE-TEST ACTIVITIES: INSTRUMENTATION CALIBRATION
 STATIC OR HOVER TESTING
 OTHER ITEMS (specify below)

II. MODEL ASSEMBLY (CONTINUED)

C. MODEL TRANSPORTED TO TUNNEL: ON THE MODEL CART SEPARATELY

D. MODEL PREPARATION:

1. FOULING CIRCUIT: YES NO

IF YES, GIVE LOCATION

2. TRANSITION GRIT - GRIT SIZE:

LOCATION:

E. TORQUE VALUES: ON TORQUE FORM (TIF 1) ON MODEL DRAWINGS

III. WIND TUNNEL PARAMETERS

A. TEST SECTION CONFIGURATION (CLOSED, SLOTTED, OPEN, ETC.):

B. TEST DYNAMIC PRESS. (Q) OR VELOCITY RANGE:

C. TEST SECTION MODEL CART CONFIGURATION:

FRONT BAY:

AFT BAY:

D. MODEL ATTITUDE RANGE:

PITCH:

YAW:

ROLL:

E. FLOOR BOUNDARY LAYER EXHAUSTER: YES NO

F. MODEL HEIGHT (ground-effects testing)

1. MINIMUM HEIGHT TO BE TESTED:

LIMIT SWITCH NEEDED

2. MODEL HEIGHT REFERENCE POINT:

IV. ENGINE SIMULATION

A. LOW PRESSURE AIR (House Air): YES NO

B. HIGH PRESSURE AIR: YES (If yes, fill out form TIF 2) NO

1. AIR STATION USED: AIR STATION NO. 1 AIR STATION NO. 2 AIR STATION NO. 3
5000 psi 1800 psi 5000 psi

2. FLOWMETERS: FMCODE THROAT SIDE (diameter, in.)

C. MOTOR GENERATOR (M-G) SET: YES (If yes, please specify below) NO

240KVA

62.5 KVA LOW SPEED

62.5 KVA HIGH SPEED

V. INSTRUMENTATION USED IN THE TEST

A. NUMBER OF BALANCES USED (see Section VI - Balance Information):

B. NUMBER OF PRESSURE TRANSDUCERS USED:

TRANSDUCER RANGES:

C. NUMBER OF THERMOCOUPLES USED:

V. INSTRUMENTATION USED IN THE TEST (CONTINUED)

D. NUMBER OF ESP MODULES TO BE USED: NO. OF PORTS / MODULE

PRESSURE RANGES: Press. units: psf psi other

Fill out Form TIF 3 for ESP module Information

PRESSURE PRINT-OUT FORMAT: Differential Absolute Coefficient

E. OTHERS:

VI. BALANCE INFORMATION (maximum of 4 balances)

	1	2	3	4
Balance Name				
Balance Type *				
X-transfer, in.				
Y-transfer, in.				
Z-transfer, in.				
gamma1, deg.				
gamma2, deg.				
gamma3, deg.				
S, sq. ft.				
c, in.				
b, in.				
Max. NF				
Max. AF				
Max. PM				
Max. RM				
Max. YM				
Max. SF				

* Balance Type: R = NF, AF, PM, RM, YM, SF T = N1, AF, N2, RM, S1, S2

VII. DATA ACQUISITION

A. DATA ACQUISITION SYSTEMS: STATIC (MODCOMP) DYNAMIC LASER VELOCIMETRY
 OTHERS (Specify):

B. NUMBER OF DATA CHANNELS: ANALOG (use form TIF 4): DIGITAL (use form TIF 5):
OTHERS (Specify):

C. FLOW VISUALIZATION

1. RECORDING: PHOTOGRAPHY VIDEO MOTION PICTURE (film)

CAMERA LOCATIONS:

2. FLOW VISUALIZATION TECHNIQUES:

SMOKE OIL TUFTS MINITUFTS LASER LIGHT SHEET

OTHERS (Specify):

HIGH PRESSURE AIR SET-UP FOR POWERED MODELS
14-BY 22-FOOT SUBSONIC TUNNEL AND FACILITIES

TEST NUMBER: _____ PROJECT ENGINEER: _____

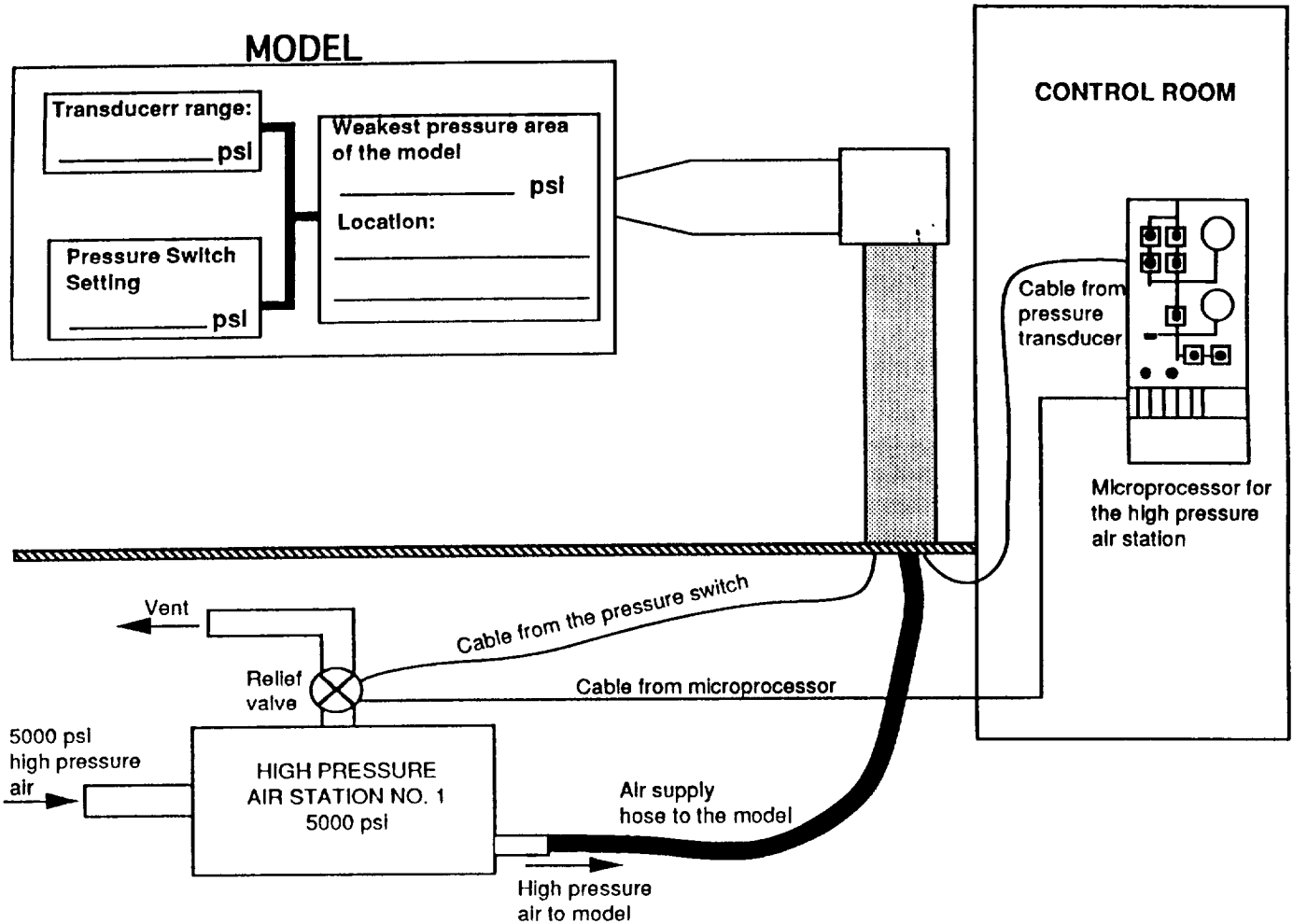

Write the maximum working pressure of the weakest pressure area in the model or the support system in the sketch above. Also, specify the maximum pressure for both the transducer and the pressure switch to activate the relief valve at Air Station No. 1

1. All flex hoses and piping used in the test must be rated for 5000 psi working pressure, using Air Station No. 1 or 3.
2. The transducer and the pressure switch are set to the maximum working pressure of the weakest pressure area in the model or sting.
3. The relief valve at Air Station No. 1 is activated by either the pressure switch or the pressure transducer through the high pressure air station microprocessor when either reaches the maximum preset pressure.

ESP MODULE INFORMATION
14-BY 22-FOOT SUBSONIC TUNNEL AND FACILITIES

TEST NUMBER: _____ PROJECT ENGINEER: _____

The information of 2 Electronically Scanned Pressure (ESP) modules can be entered on this form. This form will be used by the technician to connect the ESP modules to the pressure ports in the model.

Number of ESP modules used: _____ . Page _____ of _____ .

ESP Module No.: _____					ESP Module No.: _____				
Model Port No.	X location	Y location	Z location	Description	Model Port No.	X location	Y location	Z location	Description
1					1				
2					2				
3					3				
4					4				
5					5				
6					6				
7					7				
8					8				
9					9				
10					10				
11					11				
12					12				
13					13				
14					14				
15					15				
16					16				
17					17				
18					18				
19					19				
20					20				
21					21				
22					22				
23					23				
24					24				
25					25				
26					26				
27					27				
28					28				
29					29				
30					30				
31					31				
32					32				
33					33				
34					34				
35					35				
36					36				
37					37				
38					38				
39					39				
40					40				
41					41				
42					42				
43					43				
44					44				
45					45				
46					46				
47					47				
48					48				

Page No. _____

ANALOG DATA CHANNELS TO BE USED ON THE TEST
14-BY 22-FOOT SUBSONIC TUNNEL AND FACILITIES

TEST NUMBER: _____ PROJECT ENGINEER: _____

Channel types: 0 = R
 1 = $(R - Z) \times C + \text{Offset}$
 2 = $(R - Z) \times C + \text{Offset}$
 3 = $\text{ASIN}((R - Z) \times C) + \text{Offset}$
 4 = $\text{ASIN}((R - Z) \times C) + \text{Offset}$
 5 = $\text{ASIN}((R \times C) + (R \times R \times U) + \text{Offset}$

Where: R = channel reading
 Z = zero data reading
 ZI = input zero
 C = sensitivity constant
 U = 2nd order constant in USERP(100)

Voltage:: 2 to 10 volts (or 0 to 99.99 volts bulk power) Filter: 1, 10, 100, 1000Hz Range: 20 mV, 160 mV, 1.28 V, 10.24 V

LIST ALL ANALOG DATA CHANNELS USED IN THE TEST, INCLUDING BALANCES, TRANSDUCERS, THERMOCOUPLES, ETC.

	Name	Type	Units	Calibration Range	Voltage	Filter	Range	Description	MIF	MDCMP
1										
2										
3										
4										
5										
6										
7										
8										
9										
10										
11										
12										
13										
14										
15										
16										
17										
18										
19										
20										
21										
22										
23										
24										
25										
26										
27										
28										
29										
30										
31										
32										

DIGITAL DATA CHANNELS TO BE USE ON THE TEST
14-BY 22-FOOT SUBSONIC TUNNEL AND FACILITIES

TEST NUMBER: _____ PROJECT ENGINEER: _____

Channel types: 0 = R

- 1 = $(R - Z) \times C + \text{Offset}$
- 2 = $(R - Z_i) \times C + \text{Offset}$
- 3 = $\text{ASIN} ((R - Z) \times C) + \text{Offset}$
- 4 = $\text{ASIN} ((R - Z_i) \times C) + \text{Offset}$
- 5 = $\text{ASIN} ((R \times C) + (R \times R \times U)) + \text{Offset}$

Where: R = channel reading
 Z = zero data reading
 Z_i = input zero
 C = sensitivity constant
 U = 2nd order constant in USERP(100)

LIST ALL DIGITAL DATA CHANNELS USED IN THE TEST, INCLUDING MENSORS, ENCODERS, TACHOMETERS, ANY BCD OR BINARY OUTPUT, ETC.

	Name	Type	Units	Calibration Range	Filter	Description	MIF	MDCMP
1								
2								
3								
4								
5								
6								
7								
8								
9								
10								
11								
12								
13								
14								
15								
16								

DATA DISPLAY PAGE DEFINITIONS

14-BY 22-FOOT SUBSONIC TUNNEL AND FACILITIES

TEST NUMBER: _____ PROJECT ENGINEER: _____

Data Display are available on 19 inch ISC displays. 23 parameters or variables can be seen on a single page (date and time has line 13 locked). There are 24 display pages available

COLORS FOR FOREGROUND AND BACKGROUND DISPLAY LINES:

Black(BLK), blue(BLU), white(WHT), cyan(CYN), green(GRN), magenta(MAG), red(RED), and yellow(YEL).
NOTE: Do not use RED or YEL in the display lines because these colors indicate limit near or out conditons.

Format (FMT): I*2, I*4 (default), R*4, R*6, R*8, or CHR (8 character).

Channel Number (Ch. No.): 0 to 127 - analog, 512 to 775 - digital, and 2000 to 4047 - ESP

Number of Data Display pages: _____ This page is _____ of _____. OWNER initials: _____
(For Data Reduction Group use)

Please use one Form TIF 6 for each display page.

	Name / Parameter	Color		Dec. Pt.	Units	L. limit	U. limit	For Data Reduction Group use			
		Frgrnd	Bkgrnd					Lock	Ch. No.	Addrss	FMT
1											
2											
3											
4											
5											
6											
7											
8											
9											
10											
11											
12											
13	Date and time							yes			
14											
15											
16											
17											
18											
19											
20											
21											
22											
23											
24											

Page No. _____

TUNNEL DISPLAY INFORMATION
14-BY 22-FOOT SUBSONIC TUNNEL AND FACILITIES

TEST NUMBER: _____ PROJECT ENGINEER: _____

THESE 14 IN. ISC DISPLAYS ARE LOCATED AT OR NEAR EACH TUNNEL CONTROL STATION, SO TECHNICIANS CAN MONITOR CERTAIN PARAMETERS FOR THAT PARTICULAR STATION.

Parameter names in paranthesis are the default parameters.

Parameter names must match the ones in the data base.

DISPLAY NO. A
Tunnel Operation
Station

Line 1	(TA)
Line 2	(PA)
Line 3	(VEL)
Line 4	(Q)
Line 5	
Line 6	

DISPLAY NO. B
Model Attitude and
Altitude Station

Line 1	(PITCH)
Line 2	(HGT)
Line 3	(BETA)
Line 4	(ALPHA)
Line 5	
Line 6	

DISPLAY NO. C
High Pressure Air
Station

Line 1	(FMP1)
Line 2	(PST)
Line 3	(FMTDE)
Line 4	(NPR)
Line 5	
Line 6	

DISPLAY NO. D
Rotor Control
Station

Line 1	
Line 2	
Line 3	
Line 4	
Line 5	
Line 6	

DISPLAY NO. E
MG Set Control
Station

Line 1	
Line 2	
Line 3	
Line 4	
Line 5	
Line 6	

DISPLAY NO. F
Roll Sting Control
Console

Line 1	(GPITCH)
Line 2	(GROLL)
Line 3	(PITCH)
Line 4	(YAW)
Line 5	
Line 6	

ON-LINE PLOTTING INFORMATION
14-BY 22-FOOT SUBSONIC TUNNEL AND FACILITIES

TEST NUMBER: _____ PROJECT ENGINEER: _____

PLOTTING LOCATIONS ON THE SCREEN:

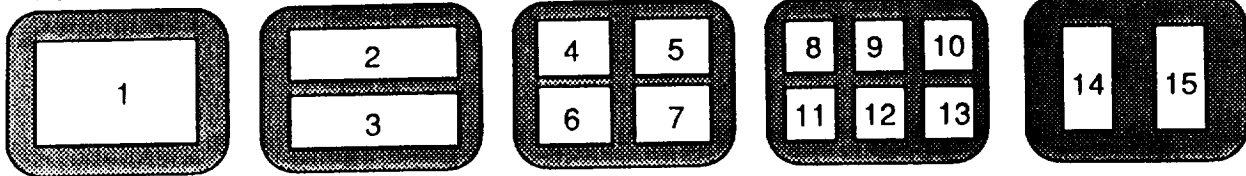

REFER TO THE USERS' MANUAL FOR FURTHER INSTRUCTIONS ON THE USE OF ON-LINE (REAL TIME) PLOTTING AND ITS OPTIONS.

Number of plots per page _____ Plotting file name: _____

	MAX. OF 6 PLOTS ON THE PAGE					
PLOT LOCATION						
ABSCISSA NAME (X-AXIS)						
MIN. X						
MAX. X						
DEL. X						
ORDINATE NAME (Y-AXIS)						
MIN. Y						
MAX. Y						
DEL. Y						
PFACTOR*						
ORIFICE RANGE*						

* For pressure plotting only

Number of plots per page _____ Plotting file name: _____

	MAX. OF 6 PLOTS ON THE PAGE					
PLOT LOCATION						
ABSCISSA NAME (X-AXIS)						
MIN. X						
MAX. X						
DEL. X						
ORDINATE NAME (Y-AXIS)						
MIN. Y						
MAX. Y						
DEL. Y						
PFACTOR*						
ORIFICE RANGE*						

* For pressure plotting only

REPORT DOCUMENTATION PAGE			Form Approved OMB No. 0704-0188	
Public reporting burden for this collection of information is estimated to average 1 hour per response, including the time for reviewing instructions, searching existing data sources, gathering and maintaining the data needed, and completing and reviewing the collection of information. Send comments regarding this burden estimate or any other aspect of this collection of information, including suggestions for reducing this burden, to Washington Headquarters Services, Directorate for Information Operations and Reports, 1215 Jefferson Davis Highway, Suite 1204, Arlington, VA 22202-4302, and to the Office of Management and Budget, Paperwork Reduction Project (0704-0188), Washington, DC 20503.				
1. AGENCY USE ONLY (Leave blank)	2. REPORT DATE November 1993	3. REPORT TYPE AND DATES COVERED Technical Memorandum		
4. TITLE AND SUBTITLE User's Manual For The Langley Research Center 14- by 22-Foot Subsonic Tunnel Static Data Acquisition System			5. FUNDING NUMBERS 535-03-10-02	
6. AUTHOR(S) Nettie M. Orié and P. Frank Quinto				
7. PERFORMING ORGANIZATION NAME(S) AND ADDRESS(ES) NASA Langley Research Center Hampton, VA 23681-0001			8. PERFORMING ORGANIZATION REPORT NUMBER	
9. SPONSORING / MONITORING AGENCY NAME(S) AND ADDRESS(ES) National Aeronautics and Space Administration Hampton, VA 23681-0001			10. SPONSORING / MONITORING AGENCY REPORT NUMBER NASA TM-109027	
11. SUPPLEMENTARY NOTES				
12a. DISTRIBUTION / AVAILABILITY STATEMENT Unclassified - Unlimited Subject Category 02			12b. DISTRIBUTION CODE	
13. ABSTRACT (Maximum 200 words) The Static Data Acquisition System (SDAS) components primarily responsible for acquiring data at the 14- by 22-Foot Subsonic Tunnel are the NEFF 620/600 Data Acquisition Unit (DAU) and the PSI 780B electronically scanned pressure (ESP) measurement system. A 9250 Modcomp computer is used to process the signal, to do all aerodynamic calculation, and to control the output of data. All of the tasks required to support a wind tunnel investigation are menu driven. The purpose of this report is to acquaint users of this system with the wide range of capabilities that exist with the available hardware and software and provide them with the proper procedures to follow when setting up or running individual tests.				
14. SUBJECT TERMS Data Acquisition, Wind Tunnels, Subsonic Research			15. NUMBER OF PAGES 107	
			16. PRICE CODE A06	
17. SECURITY CLASSIFICATION OF REPORT Unclassified	18. SECURITY CLASSIFICATION OF THIS PAGE Unclassified	19. SECURITY CLASSIFICATION OF ABSTRACT Unclassified	20. LIMITATION OF ABSTRACT	