

1N-37
198128

NASA
Technical Memorandum 106431

Army Research Laboratory
Technical Report ARL-TR-318

17P

The Relative Noise Levels of Parallel Axis Gear Sets With Various Contact Ratios and Gear Tooth Forms

Raymond J. Drago, Joseph W. Lenski, Jr., and Robert H. Spencer
Boeing Helicopters
Philadelphia, Pennsylvania

Mark Valco
Vehicle Propulsion Directorate
U.S. Army Research Laboratory
Lewis Research Center
Cleveland, Ohio

and

Fred B. Oswald
National Aeronautics and Space Administration
Lewis Research Center
Cleveland, Ohio

Prepared for the
Fall Technical Meeting of the
American Gear Manufacturers Association
Detroit, Michigan, October 14-15, 1993

N94-21756

Unclas

G3/37 0198128

(NASA-TM-106431) THE RELATIVE NOISE LEVELS OF PARALLEL AXIS GEAR SETS WITH VARIOUS CONTACT RATIOS AND GEAR TOOTH FORMS (NASA) 17 p



(

(

The Relative Noise Levels of Parallel Axis Gear Sets With Various Contact Ratios and Gear Tooth Forms

Raymond Drago, Joseph W. Lenski, Jr., and Robert H. Spencer
Boeing Helicopters
Philadelphia, Pennsylvania 19142

Mark Valco
Vehicle Propulsion Directorate
U.S. Army Research Laboratory
Lewis Research Center
Cleveland, Ohio 44135

Fred B. Oswald
National Aeronautics and Space Administration
Lewis Research Center
Cleveland, Ohio 44135

Abstract

The real noise reduction benefits which may be obtained through the use of one gear tooth form as compared to another is an important design parameter for any geared system, especially for helicopters in which both weight and reliability are very important factors. This paper describes the design and testing of nine sets of gears which are as identical as possible except for their basic tooth geometry. Noise measurements were made at various combinations of load and speed for each gear set so that direct comparisons could be made. The resultant data was analyzed so that valid conclusions could be drawn and interpreted for design use.

INTRODUCTION

The problem of gear noise in helicopter transmissions is ever present. The main exciting forces which produce this noise are the meshing forces of the gear teeth in the transmission. While this is certainly an oversimplification, since many factors influence transmission noise aside from the gear mesh forces, the simple fact remains that if the basic exciting forces are reduced and no amplifying factors are present, the overall noise level of the system will be reduced.

Among the several ways in which the gear tooth meshing forces may be reduced, two of the most directly applicable to helicopter transmissions are the form of the teeth and the overall contact ratio. Both approaches are quite attractive for an aerospace application since, unlike other "treatment" methods, which are applied with penalties to either system weight or performance, these approaches have the potential for reducing noise without causing any increase in overall system weight or reducing performance. In fact, both approaches also offer the possibility of actually providing improved gear performance in terms of longer life, higher load capacity, improved reliability, and reduced weight while simultaneously reducing noise levels.

The objective of this program was to define, by controlled testing and actual noise measurements, the effect of changes in the profile, face, and

modified contact ratios and the gear tooth form, separately and in combination, for spur and helical gears, on the noise levels produced by otherwise identical spur and helical gears. In order to accomplish this objective, a program was defined to design appropriate gears (Table I), fabricate a sufficient number of test specimens, and conduct the testing required.

While a wide range of specimens is shown, they were all configured as nearly alike as practical, within the limitations imposed by manufacturing considerations and the test stand. Testing was conducted in a single mesh gear box under controlled conditions which were maintained as nearly identical as possible. Acoustic intensity measurements were taken with the aid of a robot to insure repeatability of measurement between gear sets and to minimize human technique influence.

TEST GEAR DESIGN

Eight (8) sets of gears, four (4) spur and four (4) helical as listed in Table I, compatible with the NASA Lewis gear noise test rig, were designed. Of the four sets of spur gears, two sets have an involute tooth form and two utilize a noninvolute, constant radius of curvature tooth form. All gears were designed in accordance with normal Boeing Helicopters practice so that, except for size, they are representative of typical helicopter gears.

Table I Gear Noise Test Matrix

Configuration	Tooth Form	Type	Contact Ratios		
			Profile	Face	Modified
1. Conventional Spur Baseline	Involute	Spur	1.25	0.00	1.25
2. HCR-INV	Involute	Spur	2.15	0.00	2.15
3. Conventional Single Helical Baseline	Involute	Helical	1.25	1.25	1.77
4. Double Helical	Involute	Helical	1.25	1.25	1.77
5. HCR-INV	Involute	Helical	1.25	1.75	2.15
6. HCR-INV	Involute	Helical	2.15	2.25	3.11
7. NIF Baseline	NonInvolute	Spur	1.25	0.0	1.25
8. NIF-HCR	NonInvolute	Spur	2.15	0.0	2.15

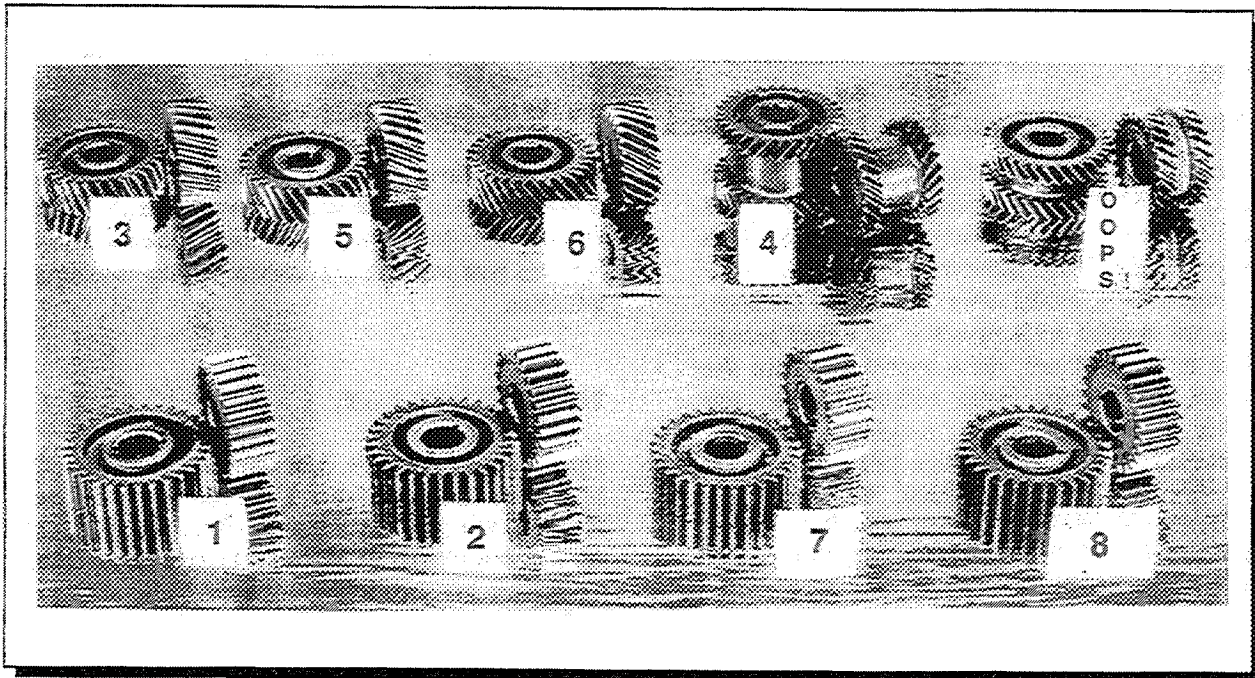

Figure 1 - Test Gears

Table II - Basic Test Gear Configuration

	Pinion	Gear
Number of Teeth	25	31
Diametral Pitch, Transverse	8.	
Center Distance	3.50	
Pressure Angle, Transverse	25 (Std Profile Contact Ratio)	
	20 (High Profile Contact Ratio)	
Face Width (Spur & Single Helical)	1.25	
Face Width (Double Helicals)	Double Helicals 0.625 ea Helix	

Since these gears were tested in the NASA test rig, it was also necessary to maintain compatibility with the test rig. The standard NASA test gears incorporated a loose fit between the gear bore and the shaft outside diameter. In order to be sure that the noise test results, especially for the helical gears, were not affected by this loose fit, it was changed to a press fit which would be more typical of that used in a helicopter application. While this change caused some difficulty in changing from one configuration to another, it was important from a test validity point of view. Previous¹ NASA testing of Boeing Helicopters designed small gears using the high profile contact ratio noninvolute tooth form (HCR-NIF) indicated that their surface load capacity was substantially higher than that of conventional involute gears and that their bending load capacity (at torque loads) was at least equal to and actually slightly greater than the standard involute gears. The scoring resistance of the HCR-NIF gears, in the NASA tests, appeared to be lower than that of equivalent standard gears. The lower scoring load capacity performance may have been due to inadequate profile modification on the small test gears therefore the HCR-NIF gears for this testing incorporated improved profile modifications.

The test gear configurations were selected to be representative of those which are either actually in use or have near term potential of being used in helicopter transmissions. While lower noise levels are generally associated with helical gears as compared to spurs, there was no definitive data, for accurate, ground tooth gears, which defines the noise advantage which may be obtained. Similarly, anecdotal information indicates that higher contact ratios, both face and profile, also tend to reduce noise levels but, again, hard data was not readily available.

While helical gears provide some noise reduction, their use also generates a thrust load which must be dealt with in the design of the overall system, especially the support bearings, gear blank design, and housing structure. Double helical gears provide some relief from the net thrust problems, however, the thrust loads from each helix must still be cancelled within the gear blank and the overall effect of this on the noise level of the gear has not been studied at all.

New tooth forms of various noninvolute types have been investigated for possible use in helicopter transmissions in recent years but these investigations have centered almost universally on the load capacity

aspect of the forms and not their noise behavior. One of these has demonstrated some potential for improved load capacity in previous testing.

Considering all of these factors, the range of gear configurations defined in Table I and shown in Figure 1 was selected to provide some basic answers to their respective noise behaviors. The basic gear tooth data for the test gears is provided in Table II.

TEST FACILITY

The NASA Lewis Research Center gear noise rig, Figure 2, was used for these tests. This rig features a single-mesh gearbox powered by a 150 kW (200 hp) variable speed electric motor. A poly-V belt drive was used as a speed increaser between the motor and input shaft. An eddy-current dynamometer loads the output shaft at speeds up to 6000 rpm. The rig was built to carry out fundamental studies of gear noise and the dynamic behavior of gear systems. It is designed to allow testing of various configurations of gears, bearings, dampers and supports.

To reduce unwanted reflection of noise, acoustical absorbing foam baffles cover test cell walls, floor, and other surfaces. The material attenuates reflected sound by 40 dB for frequencies of 500 Hz and above.

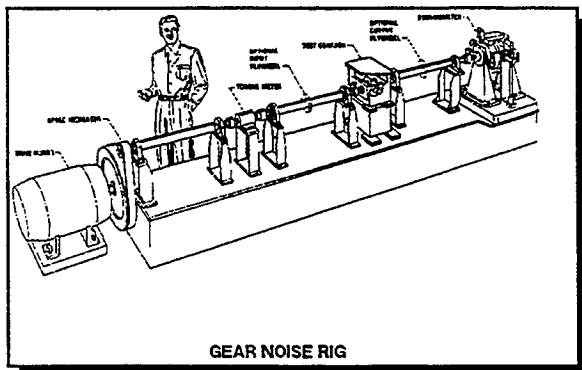

Figure 2 - Nasa Gear Test Rig

A 20 node measurement grid was drawn on the top cover of the gear box and used to insure repeatability of the noise measurements and to aid in avoiding operator induced errors. The grid covers an area 228 x 304 mm (9 x 12 in) centered on the 286 x 362 mm (11.25 x 14.25 in) top. A cutaway section of the test gear box is shown in Figure 3. All data was collected

using the computer controlled robot arm coordinated with the reference grid so that no matter what gear set was running, the readings were identically taken.

INSTRUMENTATION

An experimental modal test was performed to determine the modes of vibration and natural frequencies of the gearbox top. An 800 line, 2-channel dynamic signal analyzer collected frequency-domain data. Commercial modal software running on a personal computer was used for the analysis. The tests were performed with the gearbox heated to operating temperature. The structure was excited sequentially at each of the 63 nodes using a load cell equipped modal hammer to measure excitation forces. The response was measured with a small piezoelectric accelerometer mounted at a reference location near the center of the gearbox top.

The gear box modal test was not accomplished as part of this program. The modal testing was performed as part of a previous program². Modal test results were used to assure that gear mesh frequencies did not coincide with important modes of the gear box.

NOISE MEASUREMENTS

Acoustic intensity measurements were performed, under stable, steady-state operating conditions, with the aid of a computer-controlled robot designated RAIMS^{3,4}, (Robotic Acoustic Intensity Measurement System). The RAIMS software commanded the robot, Figure 4, to move an intensity probe over a prescribed measurement grid; recorded acoustic intensity spectra in the analyzer for each node of the grid; and transmitted the spectra to the computer for storage on disk.

The acoustic intensity probe consists of a pair of phase-matched 6 mm microphones mounted face-to-face with a 6 mm spacer. The probe has a frequency range (± 1 dB) of 300-10,000 Hz. Measurements were made at a distance of 60 mm between the acoustic center of the microphones and the gearbox top.

The 20 intensity spectra collected at each operating condition were averaged, then multiplied by the radiation area to compute an 800 line sound power spectrum. The radiation area was assumed to be the area of the grid plus one additional row and column of elements or 0.0910 m². The actual area of the top is 0.1034 m². The measurement grid did not extend

completely to the edges of the gearbox top because the edge of the top was bolted to a stiff mounting flange which would not allow much movement and measurements taken close to the edge of the top would be affected by noise radiated from the sides of the box. Noise measurements from the gearbox sides were not attempted for the following reasons:

- (1) the top is not as stiff as the sides; thus, noise radiation from the top dominates
- (2) the number of measurement locations were kept reasonable; and
- (3) shafting and other projections made such measurements difficult.

Sound power measurements were made over a matrix of nine test conditions: 3 speeds (3000, 4000, 5000 rpm) and at 3 torque levels (60, 80 and 100 percent of the reference torque 256 N-m (2269 in-lb)). During each intensity scan, the speed was held to within ± 5 rpm and torque to ± 2 N-m. At least five complete sets of scans were performed on each gear set.

Acoustic intensity data were recorded over the bandwidth 896-7296 Hz. On the 800 line analyzer, this produced a line spacing of 8 Hz. We chose this frequency range because it includes the first three harmonics of gear meshing frequency for the speed range (3000-5000 rpm). In addition to the intensity data, signals from two microphones and two accelerometers were recorded on four-channel tape.

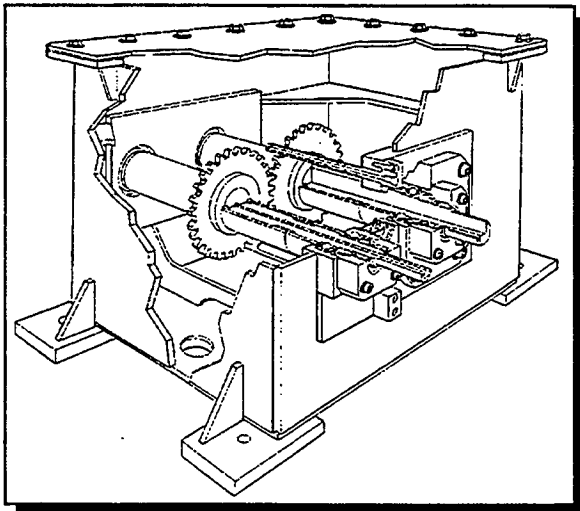

Figure 3 - Test Gear Box Cutaway Section

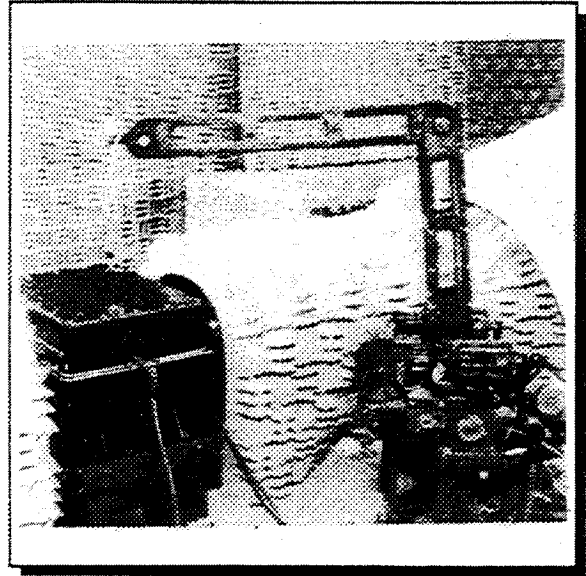

Figure 4 - Robot Noise Measurement System

PROCESSING SOUND POWER DATA

The sound power data as captured by the method outlined above consists of many data files of 800 line sound power spectra. A typical spectrum is shown in Figure 5. This trace (taken at 5000 rpm and 100 percent torque) includes the first three harmonics of gear mesh frequency. Each harmonic is surrounded by a number of sidebands.

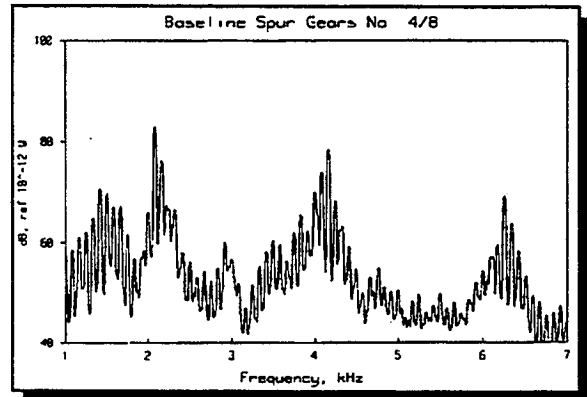

Figure 5 - Baseline Spur Spectrum

To characterize gear noise data, it was decided to reduce the 800 line sound power spectra to a single number that would represent each gear mesh harmonic. For the subject report, this is referred to as the harmonic sound power level. Five alternatives were considered for reporting of each harmonic level:

- (1) The amplitude at gear mesh frequency only (no sidebands)
- (2) The value of the largest amplitude mesh frequency harmonic or sideband, whichever is highest
- (3) The log sum of the sound intensity amplitudes in a fixed-width frequency band centered on the mesh frequency.
- (4) A value similar to (3) except the size of the frequency band varied with speed. The total number of values added is not constant.
- (5) Sum of gear mesh and fixed number of sidebands.

Alternative (5) was chosen for computing the harmonic sound power level. We used three pairs of sidebands plus the harmonics (i.e., seven peaks) in the calculation. Sound power levels were converted to Watts prior to calculating sums.

In the analysis of the intensity data, each harmonic of gear mesh frequency was defined by several digital lines of the frequency analyzer. In order to capture the total effective magnitude at each harmonic, while accounting for speed drift, etc, the peak value and two frequency lines on either side of the peak were summed. These values were converted to dB (re 10^{-12} W) to define a mesh harmonic level. Since seven peaks were used, 35 values (5×7) were summed to produce the mesh harmonic sound power level. Figure 6 illustrates the data (marked with the symbol "*"") used to produce the harmonic sound power level. This is a portion of the spectrum of Figure 5 showing the first harmonic (at 2083 Hz). The sideband spacing (for 5000 rpm) is 83 Hz, thus there are about 10 analyzer lines per sideband. At lower speeds, there are fewer analyzer lines per sideband.

DATA SAMPLING

In order to be assured that data measured on each gear set could be reliably compared with data from other gears, it was desired to have sufficient records to establish a 95% confidence level of ± 1 dB. This level is well beyond the practical difference (i.e., a change of about 3 dB) which most persons with normal hearing can detect.

Based on these considerations, the confidence limit is given by Equation 1:

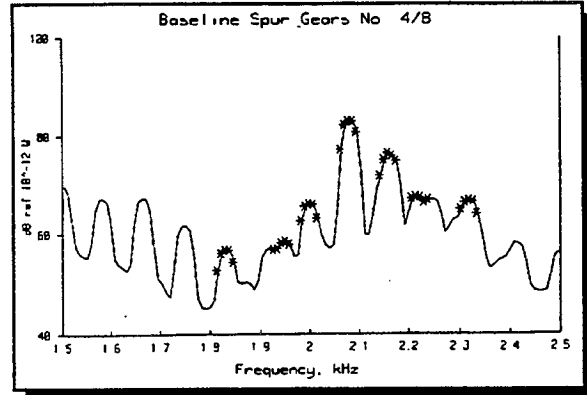

Figure 6 - Enlargement of Figure 5
(Around First Harmonic)

$$C_1 = t (\delta / \sqrt{n}) \quad (1)$$

where:

- C_1 = confidence limit, dB
- t = probability distribution ("Student t" distribution)
- δ = standard deviation of data, dB
- n = number of samples (typically 5)

The values for the "t" distribution are found in any standard statistics text. A confidence level of 95 percent corresponds to a 5% probability. The number of degrees of freedom in the "t" distribution is the number of samples minus 1 (typically 4).

To estimate the effect due to sample-to-sample variation, two sets of gears for each design were fabricated and tested. Each gear was inspected in detail in accordance with typical production helicopter standards. The overall accuracy of the gears was found to be consistent with what we expect of production helicopter gears of similar size and configuration. Based on our evaluation of the gear tooth inspection data, the variation between the two sets of gears is reasonably typical of normal production for gears in the same manufacturing lot. Lot to lot variations may be and differences between different manufacturers of the same parts certainly will be higher but the overall trend of the effect should be about the same.

We have also noted that a large difference in noise level is sometimes observed on large production gear boxes simply as a result of rebuilding them after they were disassembled for a visual inspection, even though no parts were changed. Considering this effect, in addition to the manufacturing variability checks, we also checked for variability due to disassembly and reassembly.

We accomplished this by testing three "builds" of the first gear set. Each build used exactly the same parts and each was accomplished by the same technician using the same tools, and miscellaneous parts.

TEST GEAR LOADING

The loads applied to the test gears during this program presented a problem in the design of the experiment. Obviously, if the overall gear geometry is kept constant, the stress levels under identical torque

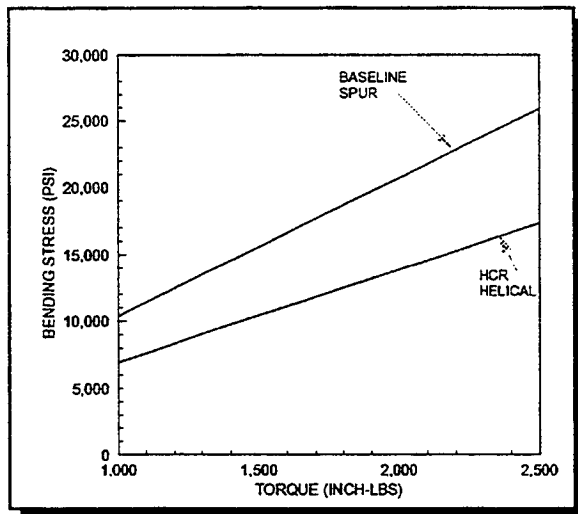

Figure 7 - Bending Stress v Torque

loading conditions will be different. An alternative to the identical torque loading method would be to apply varying torques to each configuration in order to keep the tooth stresses the same. While this seems reasonable, the question of which stress (not to mention Flash Temperature) should be held constant.

After much deliberation, the authors decided to use identical torque and speed conditions across the range of gear configurations. Since the overall geometry of the gear blanks was held constant, we believe that this approach is more representative of the actual noise which may result from a given weight or size of gear.

Better load capacity, due to lower stresses, is another factor but will be ignored for our purposes.

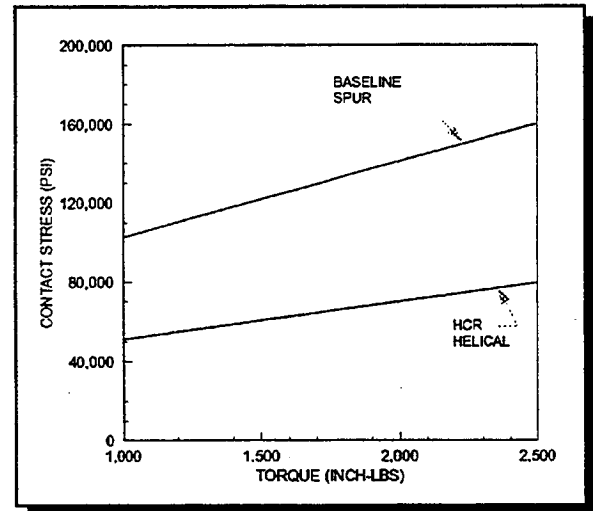

Figure 8 - Contact Stress v Torque

In order to provide an overview of the stress levels to which these gears were subjected during testing, Figures 7, 8, & 9 show the bending stress, contact stress, and flash temperature levels as functions of torque and speed. Note that, on Figure 9, the 5,000 RPM line for the baseline spur gear set (configuration 1) and the 4,000 RPM line for the HCR helical gear set (configuration 6) are virtually coincident.

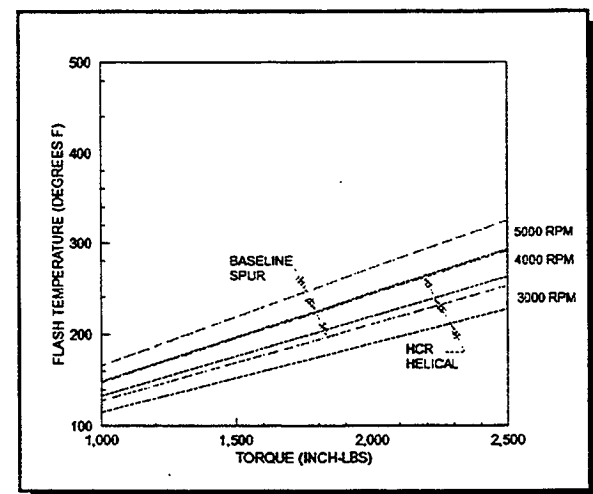

Figure 9 - Flash Temperature v Torque

The stress levels at which these gears were run during this testing are reasonably representative of those at which 10 pitch accessory gears would be run at in a typical Boeing Helicopters transmission. Main power

gears would, however, be run at considerably higher stress levels. Typically, for example, the bending stresses in a helicopter application would be about double the maximum stress run during this testing. Both the contact stress levels and the flash temperatures experienced in a typical helicopter main power transmission would be similarly higher than the test conditions defined herein.

While it would have been desirable to run the test gears at higher stress levels (more consistent with the profile modifications applied), limitations inherent in the NASA test rig loading mechanism prevented this from occurring. Still, since all results are comparative, the data obtained is quite meaningful and will provide much insight into the problem. Caution should be exercised, however, when applying these results to any practical application. The results are valid in a comparative but probably not from an absolute sense.

RESULTS

A very large amount of data has been collected during the conduct of this test program. A rather complex overview is presented in the bar chart shown in Figure 10. Note that the configuration numbering scheme followed in Table I is continued in Figure 10 (and in other similar Figures presented herein) for easy reference among the configurations tested. Considering the data shown in Figure 10, we can observe that all of the helical gears, regardless of their specific configuration, are generally significantly quieter than the equivalent spur gears and that high profile contact ratio spur gears are quieter than their equivalent standard contact ratio spur counterparts. One result which was not really anticipated in the fact that the double helical gear set was noisier than its single helical counterpart in some cases.

In order to better understand the specific ramifications of these results in terms of their application to actual design problems, it is enlightening to look at the data in terms of subgroups.

Spur Gears - Both involute and noninvolute tooth form, high profile and standard profile contact ratio spur gears were tested. Though the noise levels varied with both speed and torque loading, as Figure 11 shows, in general, the HCR spur gears (configurations 2 & 8) were quieter than the standard contact ratio spur gears (configurations 1 & 7) regardless of the tooth form. Similarly, the involute tooth form spur gears (configurations 1 & 2) were quieter than the

noninvolute tooth form gears (configurations 7 & 8), regardless of contact ratio.

An exception to this general observation occurs at the 4,000 RPM speed condition and even that exception is not completely consistent across the three torque conditions tested. At the low and medium torque conditions (i.e., 1,361 & 1,816 In-Lbs), the HCR gears were actually slightly noisier than the standard contact ratio gears. This reversal of the trend is probably related to an overall response of the gear, bearing, shaft, & housing system rather than a direct result of the gear configuration. As will be obvious from the ensuing discussion, similar effects were also observed for other gear configurations, probably related to the same, as yet unidentified, cause.

Helical Gears - As was the case for the spur gears, increasing contact ratio, both face and profile, correlate with decreasing noise levels on the helical gears. As Figure 12 shows, increasing the face contact ratio from about 1.25 (configuration 3, modified contact ratio 1.77) to 1.75 (configuration 5, modified contact ratio 2.15) decreases the noise level substantially in every case, though the results at higher speeds are more dramatic than at lower speeds.

Combining high face and profile contact ratios (configuration 6, profile, face & modified contact ratios of 2.15, 2.25, & 3.11, respectively) further increases the noise reduction which may be obtained. Indeed, in general, regardless of the configuration considered, the high profile and high face contact ratio, configuration 6, was consistently the lowest noise generator.

Helical gears used in helicopters tend to have relatively low face contact ratios (helix angles are kept low to minimize thrust loading and the extra weight associated with reacting the thrust) thus this result is especially interesting since it suggests that it is probably possible to trade off helix angle against increasing profile contact ratio to effect an improvement in noise level without the weight penalty which would be associated with accomplishing the same reduction with helix angle alone.

One surprising result was that for the double helical gear set, configuration 4. This gear set is virtually identical to the single helical gear set, configuration 3, except that it uses two identical gears of opposite hand (i.e., each hand has the same helix angle, face width, and tooth proportions as the single helical configuration 3 gears).

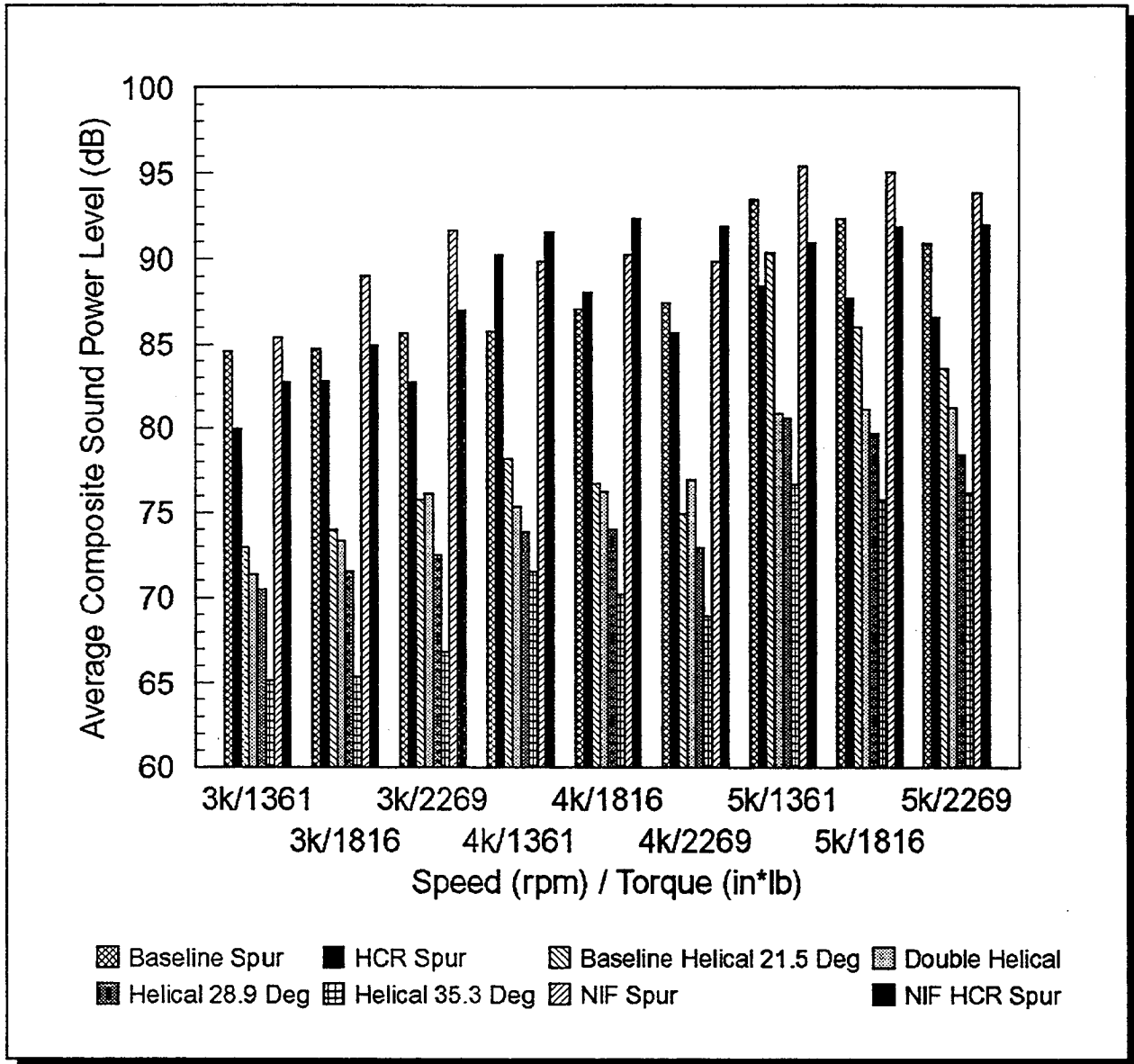

Figure 10 - Summary Of Test Results

At every operating condition, the double helical gears were either almost as noisy as or noisier than either the baseline low face and low profile contact ratio gear set (configuration 3) or the high modified contact ratio helical set, configuration 5. Initially, one would expect that the double helical gears would be about as quiet as their single helical counterparts, however this is clearly not the case.

The double helical phenomena appears to be related to the axial shuttling which occurs as the double helical gear set moves axially to balance out the net

thrust loading. The shuttling is due to the presence of small mismatches in the relative positions of the teeth on each helix. No matter how accurate the gear is, some mismatch will always be present thus this is an unavoidable phenomena.

While this feature of a double helical gear is a valuable design option since it greatly simplifies the bearing system, it is obvious that a price is paid in terms of noise (and certainly vibration) as the gear set shuttles back and forth.

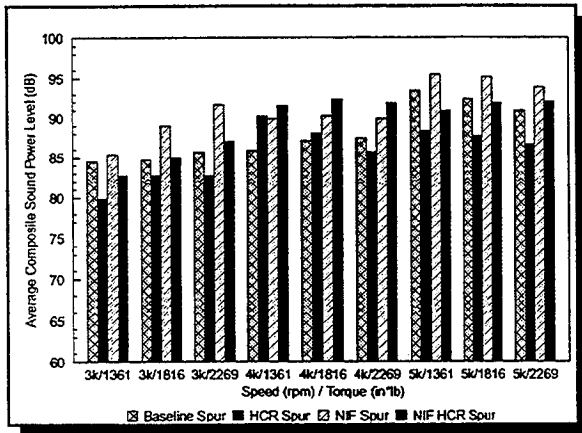

Figure 11 - Spur Gear Noise Levels

Figure 12 also shows data for a "Spread Single Helical" gear set which is not listed in Table I. This configuration was not one of the eight planned test variants. During the manufacture of the test gears, the initial double helical gear drawings went out with an inadvertent drafting error such that both helices were manufactured with the same hand. The resultant gear set (shown in the upper right corner of Figure 1) was somewhat unusual, and probably would not be used in a production environment, however, we decided to test it anyway.

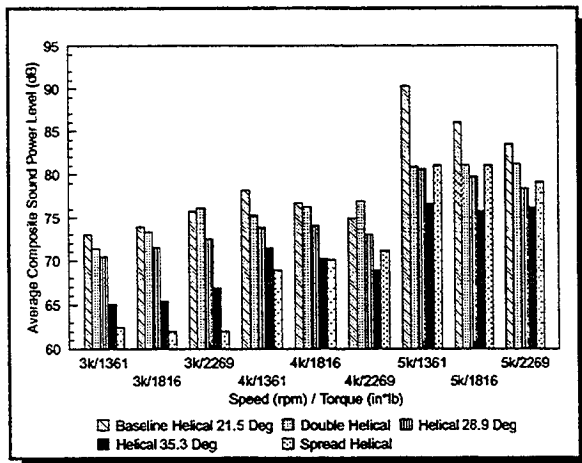

Figure 12 - Helical Gear Noise Levels

The noise results from this rather unusual gear set (which one of the author's unceremoniously dubbed the "OOPS" gear set), were surprising. It was actually quieter across the board than the double helical gear set under almost every operating condition. At first, these results were puzzling, however, after careful evaluation of the circumstances, the explanation became clear.

Since the per helix face contact ratio, face width, profile contact ratio, etc. is identical for both the OOPS and the double helical gear sets, the only operational difference is the lack of axial shuttling. The double helical set will be in a constant equilibrium seeking state because of the theoretically zero net thrust load while the OOPS gear set will run in a fixed axial position due to the net positive thrust load. This test thus provides some insight into the magnitude of the noise penalty which is paid when double rather than equivalent single helical gears are used. Since these test gears are all very accurate (accuracy typical of helicopter gears), it should be obvious that a larger penalty would be paid if gears of lesser quality were to be used because the lower the gear quality is the more shuttling would be likely to occur.

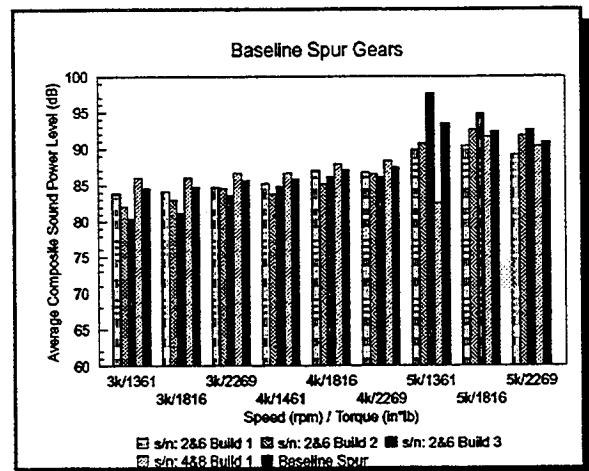

Figure 13 - Spur Gear Build Variations

If one considers the OOPS gear set to be a single helical gear set, then its effective face contact ratio would also place it between the baseline helical gear set (configuration 3) and the high face contact ratio helical gear (configuration 6). This being the case, its noise level is approximately where one would expect based on the levels of gears with higher and lower face contact ratios.

Build Variations - During other testing, the authors have noted significant variations in the measured (and perceived) noise level of the same gear system before and after disassembly. In some cases, this variation was of considerable magnitude. To investigate this phenomena, each of the gears types was assembled, tested, disassembled, and then tested again. In one case, for the baseline spur gears (configuration 1, this process was repeated three times. Similar variations in noise levels were recorded for all gear sets. Figure 13

shows the specific results for the baseline spur gears (S/N 2 & 6). The largest minimum to maximum build variation is about 8 dB (occurring at the highest speed condition) while the minimum build variation is 1 dB (occurring at the medium speed condition). Except for the low torque, highest speed condition, the average build variation is about 3 dB. While no real pattern is apparent, it does appear that the variation decreases slightly with increasing load.

Figure 13 also shows the results obtained from a second "identical" set of spur gears, S/N 4 & 8. It should be obvious that the variation between otherwise identical S/N of the same part generally exceeds the variation from rebuilding the same parts. Perhaps this is not surprising, however it does point out the need to establish noise test results over a broad range of repeated testing to insure that the differences observed are not simply due to part to part variation.

This latter effect can also be seen from Figure 14 which shows the results for two "identical" sets of the baseline helical gears. The variation observed is generally less than that observed for the spur gears but not markedly so.

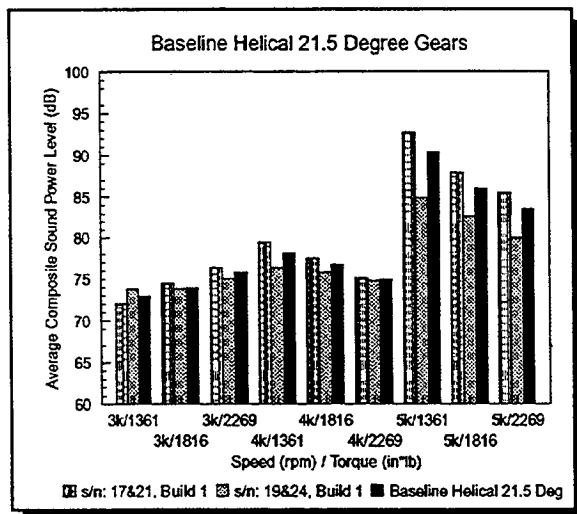

Figure 14 - Helical Gear Build Variations

It is important to again emphasize several important points about this data. Such variations, both between different builds of the same parts and among different S/N of the same part, are not at all unusual, rather they are quite common. The build variations occurred when the same physical components were simply disassembled and then reassembled under very controlled conditions and by a skilled technician. The

S/N to S/N variation occurred for helicopter quality parts in which the apparent variations in the normally accepted measures of gear quality (e.g., lead, profile, spacing, etc.) are extremely small, probably at a level where further improvements would be extremely costly.

This points out one difficulty in defining a noise reduction effort in that the variations due to these effects are often of the same order of magnitudes the changes which may be attributed to gear configuration or treatment. Such differences must at least exceed the variations due to the build effect and those observed among different S/N of the same P/N before they can be considered significant of themselves.

Torque Effect - The effect of torque on the noise level of a gear set depends on many factors. In general, however as torque increases, the noise level would be expected to increase if no other factors are at work. As described below, however, this is not the case.

This effect of torque level on gear noise will be severely impacted by the amount of profile, and in some cases lead, modification which has been applied to the gears. In the testing described herein, the profile modifications were largely the same from gear set to gear set so that we were comparing differences between gears and not between modifications. No lead modifications were made to any of the test gears. In addition, the profile modifications which were applied were calculated for the a torque substantially above the upper end of the torque range under which these gears were actually run — that is all of the gears were overmodified for the actual torque conditions encountered. It is to be expected then that as the load increases, more of the profile will come into contact as the teeth bend thus perhaps lowering the noise level. Conversely, since our maximum test torque was only about twice our minimum test torque and the absolute load levels were not extremely high, it is also likely that the tooth deflections under load were small as well. If the latter effect dominates, then the noise level would tend to increase with torque.

As Figure 15 shows (for the lowest and highest speeds only), the effect of torque on the noise level of the gears tested in this program is mixed. For the baseline spur gears (shown on Figure 15 as 0° helix angle), the noise level appears to remain about constant with torque. The helical gears, however, exhibit a slightly more varied behavior. At the low speed condition (3,000 RPM), the noise level

increases as the torque increases while at the high speed condition (5,000 RPM) the opposite appears to be true. In both cases, the overall effects are not generally dramatic.

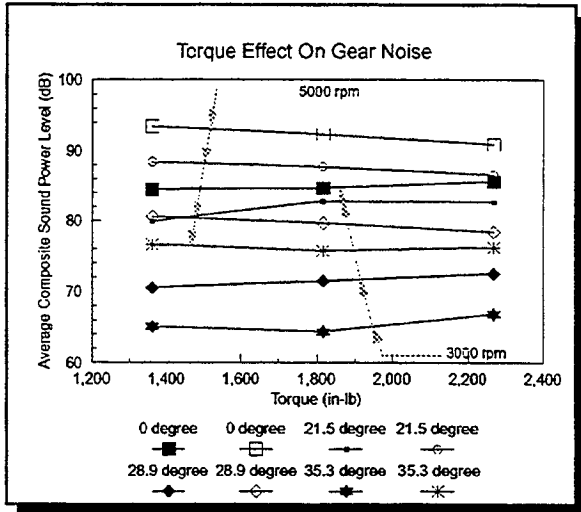

Figure 15 - Torque Effect On Gear Noise

Speed Effect - For all gears tested, increasing speed increased the noise level. Figure 16 shows the general trend for the helical gears and the baseline spurs. It is interesting to note that the increase in noise level occurs at an increasing rate as the speed increases.

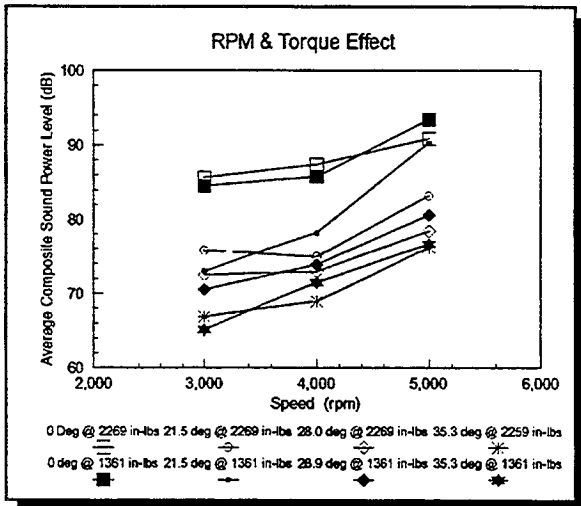

Figure 16 - Combined Speed & Torque Effects

That is the difference in noise level going from 4,000 RPM to 5,000 RPM is generally more than twice that which occurs from 3,000 RPM to 4,000 RPM. This,

of course suggests a nonlinear effect of what ever tooth errors are present. Before drawing this firm conclusion, however, other possibilities must be considered. For example, the test gear box has exhibited a response of its own at about 5,000 RPM thus the increase in noise level at this speed may be attributable (at least in part) to the housing response as well as the gears themselves.

Face Contact Ratio Effect - While noise variations which can be attributed to speed and load are certainly of interest, these factors are seldom gear design parameters over which the design engineer has substantial control. Contact ratio, which is a function of the basic tooth design, on the other hand, is a well defined parameter over which the gear design engineer has a great deal of control, once the prerequisite stress requirements are met, of course.

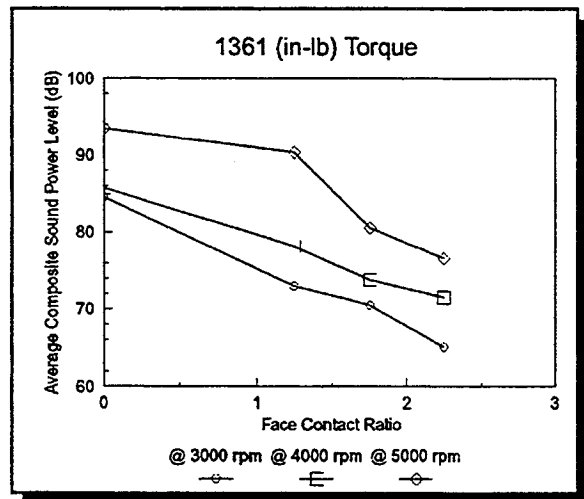

Figure 17 - Face Contact Ratio Effect Low Torque

Essentially four different helix angles were tested (0, 21.5, 28.9, & 35.3 degrees). These configurations produced gears with face contact ratios ranging from 0.0 to 2.25 and modified contact ratios ranging from 1.25 to 3.11. In all cases tested, as the contact ratio increased, the noise level decreased. As Figures 17 and 18 show, the noise reduction appears to be almost a linear function of the face contact ratio, regardless of the applied loading. Similar effects can be seen if the noise level is plotted as a function of either modified, Figure 19, or total, Figure 20, contact ratios. These latter Figures do not show quite the linearity that Figures 17 and 18 do, however.

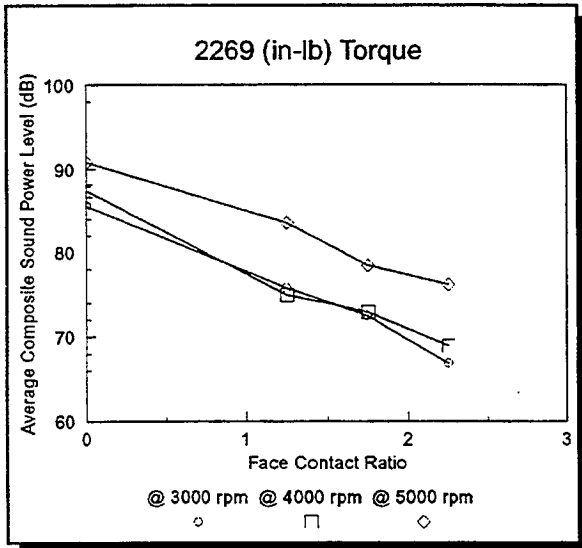

Figure 18 - Face Contact Ratio Effect High Torque

Of all of the effects investigated, it appears that the contact ratio is the most significant, if all other effects are held reasonably constant. This is important in a design for minimum noise situation since the contact ratio is one of the parameters which the gear designer can control without drastically effecting the overall configuration of the gear system. That is, by judiciously selecting the tooth proportions, helix angle, and face width, it is often possible to optimize the contact ratio to yield a minimum noise design.

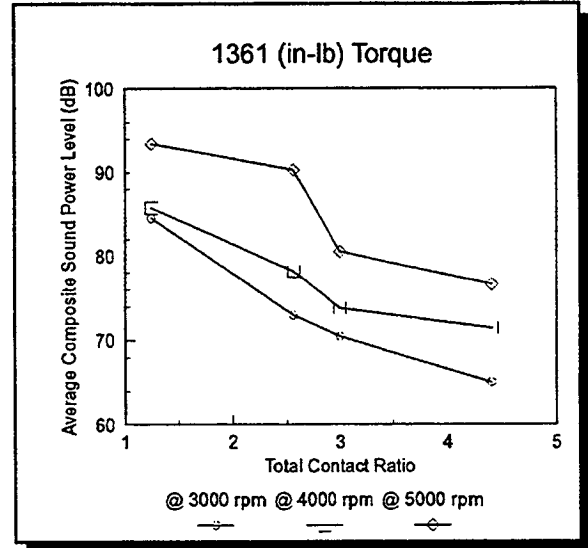

Figure 20 - Total Contact Ratio Effect

higher noise levels at virtually all speed and load conditions tested than the equivalent involute (configurations 1 & 2, respectively). The differences, as Figure 21 shows, in some cases were about the same order of magnitude as that due to the build effect described earlier. This being the case, it is hard to ascribe a specific figure to the difference in noise level other than to note the trend.

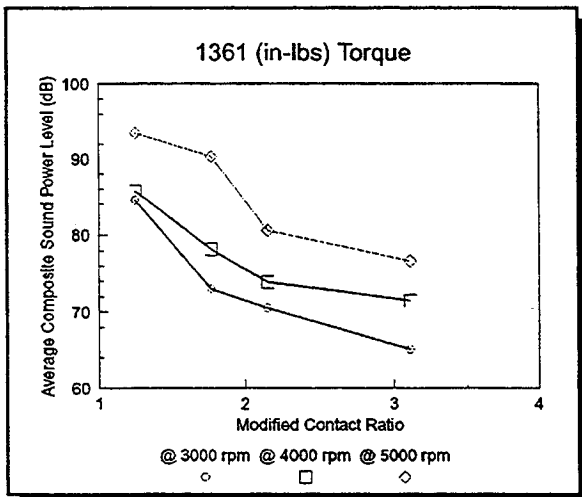

Figure 19 - Modified Contact Ratio Effect

Tooth Form - In general, the noninvolute tooth form, whether standard (configuration 7) or high profile contact ratio (configuration 8), resulted in slightly

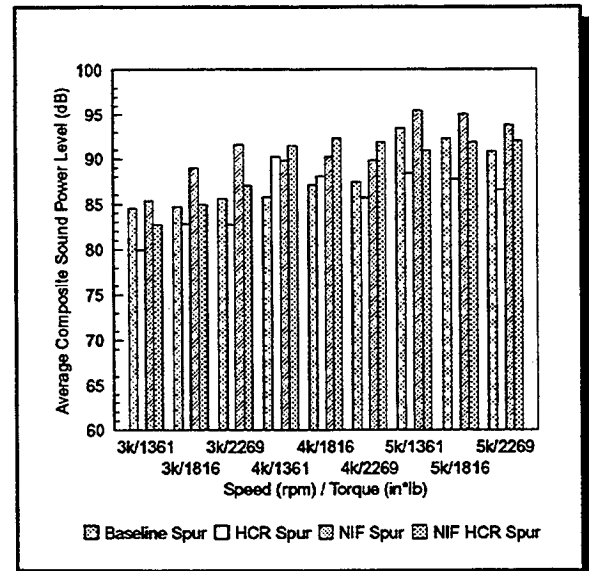

Figure 21 - Tooth Form Effect

While the difference between standard and high profile contact ratio spur gears is not really a tooth form variation in the strictest sense of the concept, it is often referred to as such. Based on the testing conducted herein, the high profile contact ratio gear sets (configurations 2 & 8) resulted in lower noise levels than their standard contact ratio counterparts (configurations 1 & 7, respectively). This effect was especially pronounced at the lower speed end of the test range and there were some exceptions, especially at the 4,000 RPM condition. Still, since high profile contact ratio does not cause any additional loading on the system (as would a helical gear), it is a viable, and possibly preferable option in many cases.

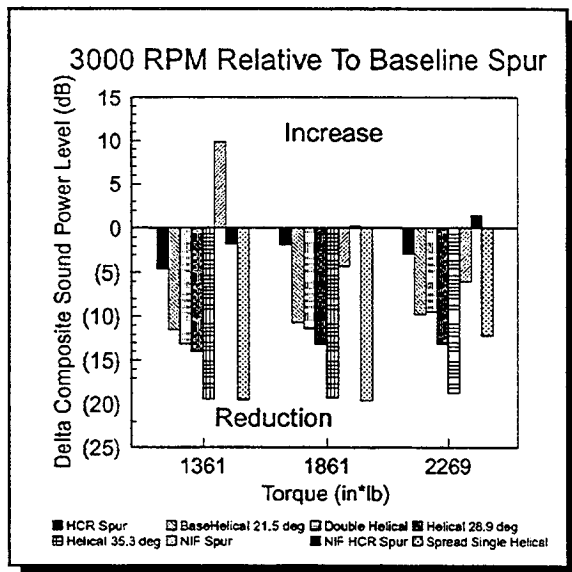

Figure 22 - 3,000 RPM Noise Summary

CONCLUSIONS

The results of this program, summarized in the difference bar charts shown in Figures 22, 23, & 24, have provided significant insight into the effects of various tooth design parameters on the noise level of a geared system. While a wide range of specific conclusions can be drawn from the data, perhaps the most significant are:

1. The contact ratio (whatever the measure) is the most significant factor within the gear design engineer's control with respect to noise reduction.
2. The noninvolute tooth form did not offer any substantial improvement in noise level.

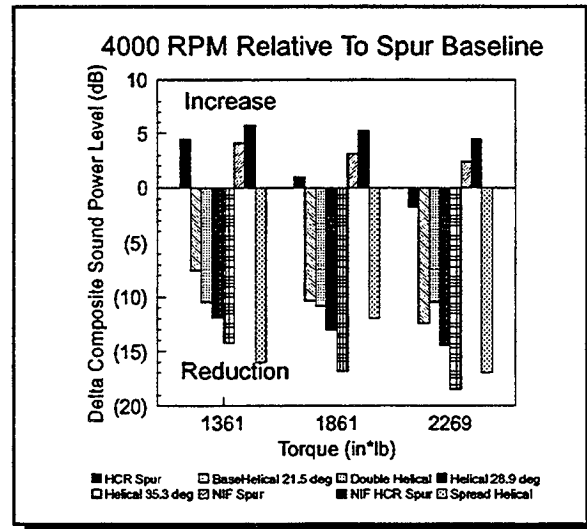

Figure 23 - 4,000 RPM Noise Summary

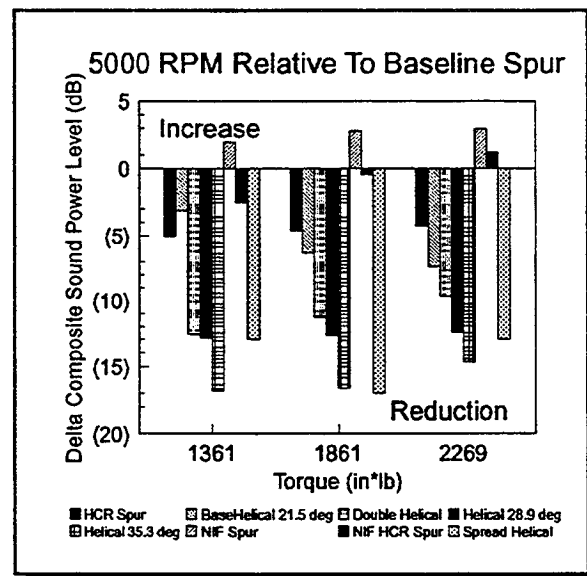

Figure 24 - 5,000 RPM Noise Summary

3. High profile contact ratio spur gears are quieter than standard profile contact ratio gears, regardless of tooth form.
4. Applied loading has a relatively small effect on noise level if the basic stress levels are low. This is probably not true for very highly loaded gear teeth, especially when the effect of profile modification is considered.
5. Speed has an increasingly detrimental effect on the noise level of the gears tested.

RECOMMENDATIONS

Since contact ratio appears to have the largest effect on noise level, it would be very interesting to test gears of identical contact ratio but varying tooth geometry. For example, a modified contact ratio of 3.11 in which the contact ratio was obtained by the combination of high helix angle and high profile contact ratio compared to a gear set in which the same contact ratio was obtained by using a standard (low) profile contact ratio in conjunction with a wide face width and low helix angle.

REFERENCES

1. Townsend, Dennis P., Baber, Berl B., and Nagy, Andrew: "Evaluation of High-Contact-Ratio Spur Gears With Profile Modification," NASA TP-1458, Sep 1979
2. Oswald, Fred B., Zakrajsek, James J., Atherton, William, and Lin Hsiang Hsi, "Effect of Operating Conditions on Gearbox Noise," Sixth International Power Transmission and Gearing Conference, American Society of Mechanical Engineers, Phoenix, AZ, Sep 13-16, 1992 (NASA TM-105331)
3. Atherton, William J., Pintz, Adam, and Lewicki, David G., 1987, "Automated Acoustic Intensity Measurements and the Effect of Gear Tooth Profile on Noise", Mechanical Signature Analysis--Machinery Vibration, Flow-Induced Vibration, and Acoustic Noise Analysis, S. Braun, et al., eds., ASME, pp. 109-113 (also NASA TM-100155).
4. Flanagan, P. M., and Atherton, W. J., 1985, "Investigation on Experimental Techniques to Detect, Locate and Quantify Gear Noise in Helicopter Transmissions", NASA CR-3847.

ACKNOWLEDGEMENT

Support of this work by the U. S. Army and the National Aeronautics and Space Administration, Lewis Research Center, under contract NAS3-25421 is gratefully acknowledged.

REPORT DOCUMENTATION PAGEForm Approved
OMB No. 0704-0188

Public reporting burden for this collection of information is estimated to average 1 hour per response, including the time for reviewing instructions, searching existing data sources, gathering and maintaining the data needed, and completing and reviewing the collection of information. Send comments regarding this burden estimate or any other aspect of this collection of information, including suggestions for reducing this burden, to Washington Headquarters Services, Directorate for Information Operations and Reports, 1215 Jefferson Davis Highway, Suite 1204, Arlington, VA 22202-4302, and to the Office of Management and Budget, Paperwork Reduction Project (0704-0188), Washington, DC 20503.

1. AGENCY USE ONLY (Leave blank)		2. REPORT DATE December 1993	3. REPORT TYPE AND DATES COVERED Technical Memorandum	
4. TITLE AND SUBTITLE The Relative Noise Levels of Parallel Axis Gear Sets With Various Contact Ratios and Gear Tooth Forms			5. FUNDING NUMBERS WU-505-62-10 1L162211A47A	
6. AUTHOR(S) Raymond J. Drago, Joseph W. Lenski, Jr., Robert H. Spencer, Mark Valco, and Fred B. Oswald				
7. PERFORMING ORGANIZATION NAME(S) AND ADDRESS(ES) NASA Lewis Research Center Cleveland, Ohio 44135-3191 and Vehicle Propulsion Directorate U.S. Army Research Laboratory Cleveland, Ohio 44135-3191			8. PERFORMING ORGANIZATION REPORT NUMBER E-8273	
9. SPONSORING/MONITORING AGENCY NAME(S) AND ADDRESS(ES) National Aeronautics and Space Administration Washington, D.C. 20546-0001 and U.S. Army Research Laboratory Adelphi, Maryland 20783-1145			10. SPONSORING/MONITORING AGENCY REPORT NUMBER NASA TM-106431 ARL-TR-318	
11. SUPPLEMENTARY NOTES Prepared for the Fall Technical Meeting of the American Gear Manufacturers Association, Detroit, Michigan, October 14-15, 1993. Raymond J. Drago, Joseph W. Lenski, Jr., and Robert H. Spencer, Boeing Helicopters, Philadelphia, Pennsylvania 19142; Mark Valco, Vehicle Propulsion Directorate, U.S. Army Research Laboratory, Lewis Research Center, Cleveland, Ohio 44135; and Fred B. Oswald, NASA Lewis Research Center. Responsible person, Fred B. Oswald, (216) 433-3957.				
12a. DISTRIBUTION/AVAILABILITY STATEMENT Unclassified - Unlimited Subject Category 37			12b. DISTRIBUTION CODE	
13. ABSTRACT (Maximum 200 words) The real noise reduction benefits which may be obtained through the use of one gear tooth form as compared to another is an important design parameter for any geared system, especially for helicopters in which both weight and reliability are very important factors. This paper describes the design and testing of nine sets of gears which are as identical as possible except for their basic tooth geometry. Noise measurements were made at various combinations of load and speed for each gear set so that direct comparisons could be made. The resultant data was analyzed so that valid conclusions could be drawn and interpreted for design use.				
14. SUBJECT TERMS Gear noise; Acoustic intensity; Spur gears, Helical gears; Tooth form; Contact ratio			15. NUMBER OF PAGES 17	
			16. PRICE CODE A03	
17. SECURITY CLASSIFICATION OF REPORT Unclassified	18. SECURITY CLASSIFICATION OF THIS PAGE Unclassified	19. SECURITY CLASSIFICATION OF ABSTRACT Unclassified	20. LIMITATION OF ABSTRACT	