

Compliant Seal Development

From notes and discussion of talk by J. Gardner, EG&G
by R.C. Hendricks

The compliant metallic seal combines the noncontact feature of the labyrinth seal, the low leakage of a mechanical seal, and the compliant nature of the brush seal. It consists of several thin metallic elements or leaves mounted within a ring which is press fit into the housing, and in form, sort of resembles a lip seal sections wiping the shaft. A second set of overlapping cover leaves are placed on top of the shaft riding leaves which reduces leakage and provides stiffness. The leaves can be straight or angle cut. The shaft riding fingers are designed with mismatched curvature to provide lift off similar to the Rayleigh lift pads in mechanical seals with leading edge clearances nearly twice those of the trailing edge as shown by Fleming to be optimal for gas flows in convergent seal passages. Leading edge clearances range from 300 to 500 microinches.

Balance pockets beneath the leaves provide fluid film feed to the "Rayleigh lift" surface and the proper balance ratio (mechanical seal) when combined with the static pressure and film pressure. The leaves flex in the radial direction and accommodate thermomechanical behavior as well as axial motion and angular misalignment.

In the static mode, there is a net closing force on the leaves.

The seals were tested to 70 psi at speeds to 16,000 rpm or surface speeds to 330 fps and temperatures from ambient to 440F. A slow cycle through the rig critical at 10,000 rpm induced a radial vibration response of 0.004 to 0.005 inch were accommodated by the seal.

Preliminary performance data are encouraging demonstrating hydrodynamic liftoff and non contacting operation at pressure and speeds typical of gas turbine engines. The leakage performance data are significantly better than commercial labyrinth and brush seals which should be expected as this design incorporates the features of the low leakage face or mechanical seal along with the flexibility of the brush configuration.

For more information

1. Gardner, J., Basu, P., and Datta, A.: A New Compliant Seal Concept for Aerospace Applications, Fourth Int. Symp. on Transport Phenomena and Dynamics of Rotating Machinery (ISROMAC-4), Vol. A, April 5-8, 1992, Honolulu, Hawaii, Sponsored by Pacific Center of Thermal-Fluid Engineering.

FIGURE 1

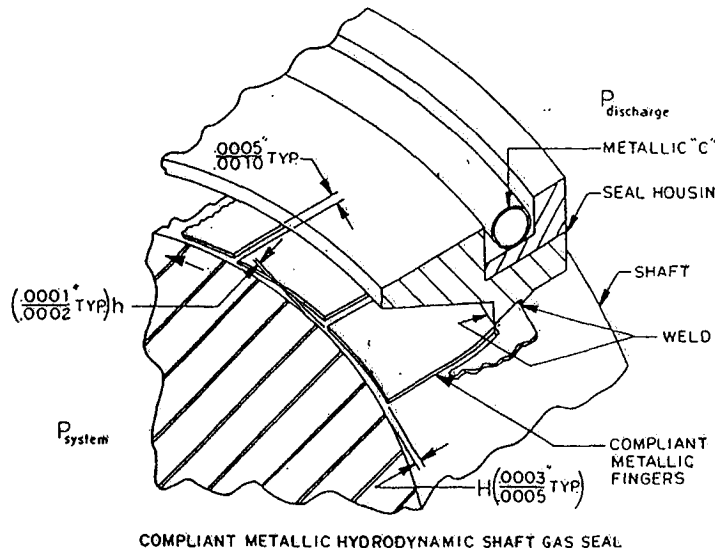

Typical Pressure Distribution for Straight Cut Compliant Seal without Slot Cover

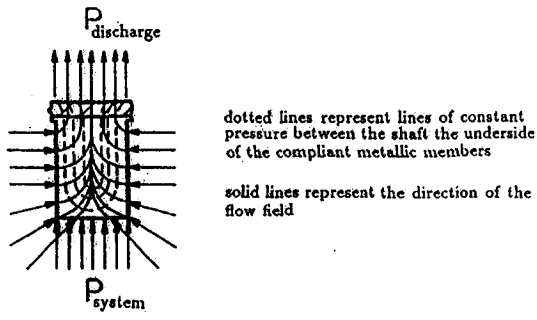

Figure 2a

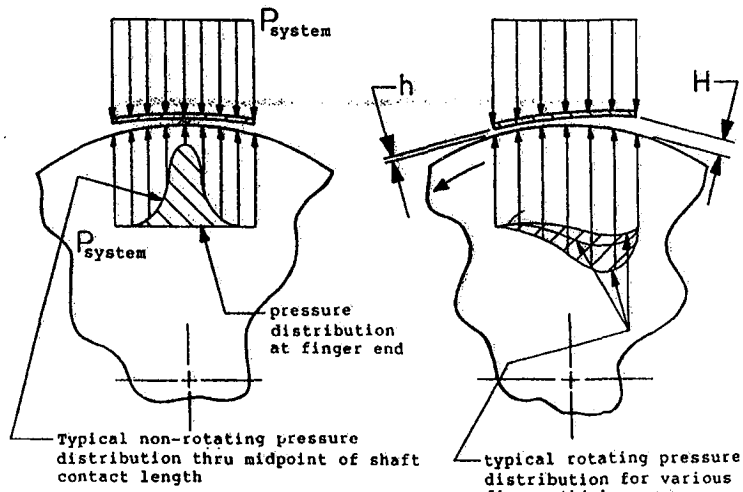
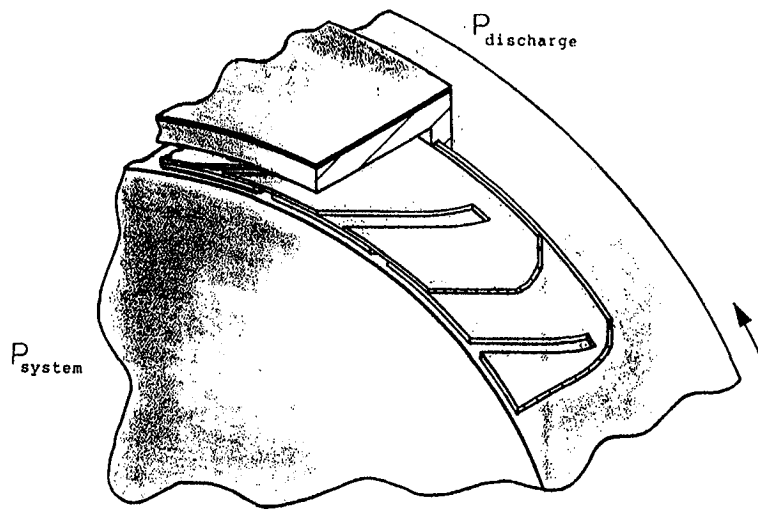

Figure 2b

Figure 2c



Angle Cut Compliant Seal with Slot Cover

Figure 3

Straight finger Compliant Seal with Rayleigh Pads and Slot Cover

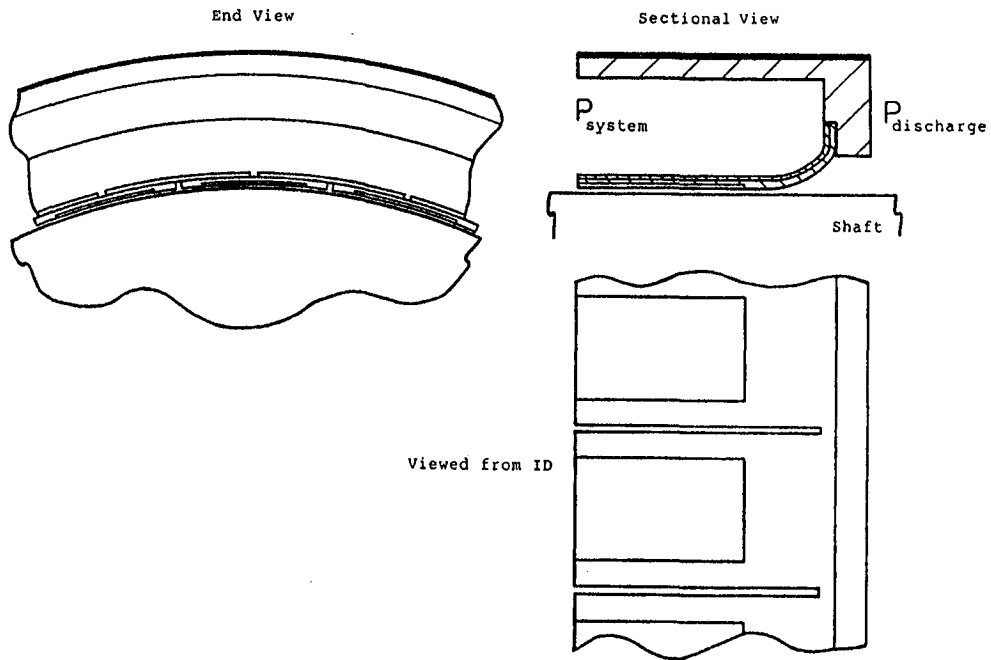

Figure 4