

NASA-CR-194750

N 11-23-CR
198253
137P

DOT/FAA/CT-92/6

FAA Technical Center
Atlantic City International Airport
N.J. 08405

Aircraft Cabin Water Spray Disbenefits Study

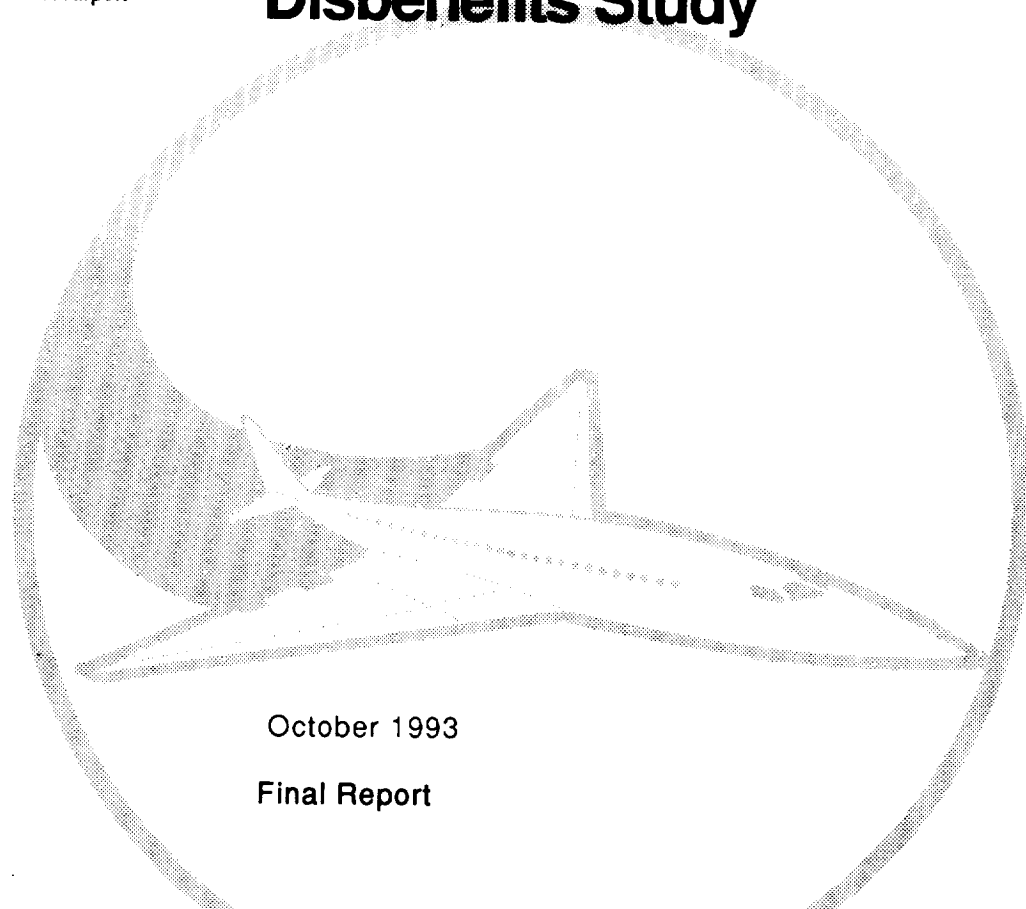

October 1993

Final Report

This document is available to the public
through the National Technical Information
Service, Springfield, Virginia 22161



U.S. Department of Transportation
Federal Aviation Administration

(NASA-CR-194750) AIRCRAFT CABIN
WATER SPRAY DISBENEFITS STUDY Final
Report (Boeing Commercial Airplane
Co.) 137 p

N94-21818

Unclas

G3/03 0198253

NOTICE

This document is disseminated under the sponsorship of the U.S. Department of Transportation in the interest of information exchange. The United States Government assumes no liability for the contents or use thereof.

The United States Government does not endorse products or manufacturers. Trade or manufacturers' names appear herein solely because they are considered essential to the objective of this report.

1. Report No. DOT/FAA/CT-92/6		2. Government Accession No.		3. Recipient's Catalog No.	
4. Title and Subtitle AIRCRAFT CABIN WATER SPRAY DISBENEFITS STUDY				5. Report Date October 1993	
				6. Performing Organization Code	
7. Author(s) Thomas L. Reynolds and Kent W. Porter				8. Performing Organization Report No.	
9. Performing Organization Name and Address Boeing Commercial Airplane Group Payload Systems P.O. Box 3707 Seattle, Washington 98124-2207				10. Work Unit No. (TRAIS)	
				11. Contract or Grant No. NASI-18027, Task 22	
12. Sponsoring Agency Name and Address National Aeronautics and Space Administration Langley Research Center M/S 126 Hampton, Virginia 23665-5225 Federal Aviation Administration Technical Center, Atlantic City International Airport Atlantic City, New Jersey 08405				13. Type of Report and Period Covered Final Report	
				14. Sponsoring Agency Code ACD-240	
15. Supplementary Notes The FAA Contracting Officer's Technical Representative (COTR) is Mr. Richard Hill, Telephone (609) 485-5997.					
16. Abstract The concept of utilizing a cabin water spray system (CWSS) as a means of increasing passenger evacuation and survival time following an accident has received considerable publicity and has been the subject of testing by the regulatory agencies in both the United States and Europe. A test program, initiated by the CAA in 1987, involved the regulatory bodies in both Europe and North America in a collaborative research effort to determine the benefits and "disbenefits" (disadvantages) of a CWSS. In order to obtain a balanced opinion of an onboard CWSS, NASA and FAA requested the Boeing Commercial Airplane Group to investigate the potential "disbenefits" of the proposed system from the perspective of the manufacturer and an operator. This report is the result of a year-long, cost-sharing contract study between the Boeing Commercial Airplane Group, NASA and FAA. Delta Air Lines participated as a subcontract study team member and investigated the "return to service" costs for an aircraft that would experience an uncommanded operation of a CWSS without the presence of fire. Disbenefits identified in the report include potential delays in evacuation, introduction of "common cause failure" in redundant safety of flight systems, physiological problems for passengers, high cost of refurbishment for inadvertent discharge, and potential to negatively affect other safety systems.					
17. Key Words Post Crash Fire Cabin Water Spray Cabin Safety Aircraft Passenger Cabin Heat Removal Toxic Gases Flashover Emergency Evacuation			18. Distribution Statement Document is available to the public through the National Technical Information Service, Springfield, Virginia 22161		
19. Security Classif. (of this report) Unclassified		20. Security Classif. (of this page) Unclassified		21. No. of Pages 148	22. Price

Preface

The following study report is based on a contract Statement of Work (SOW) between Boeing Commercial Airplane Group (BCAG) and the Federal Aviation Administration Technical Center (FAATC), for the investigation of "disbenefits" to a commercial jet aircraft created by the incorporation of a cabin water spray (CWS) system. The study required, but was not limited to, investigation of effects resulting from the commanded and uncommanded operation of a CWS system in several scenarios: airborne, takeoff, and landing approach without the presence of fire (inadvertent activation), and in the presence of fire while the aircraft is on the ground (design case). For the case of inadvertent operation, the contract also required estimates of cost associated with returning an aircraft to revenue service following water discharge.

During the course of the study, several issues which were "out-of-scope" of the original contract, but of significant concern to the study team, were identified. Those issues are presented in this preface and represent the views of the Boeing Commercial Airplane Group developed over the course of this year-long study program. While the regulatory bodies have accomplished a great deal in their research into the theoretical workings of cabin water spray systems, it is our view that there exist many practical considerations which must be addressed before water spray systems, in their current form, could be safely integrated into the commercial aircraft environment.

This report will discuss, in considerable detail, the idea of common cause failure, i.e., an abnormal failure mechanism that causes the simultaneous failure of redundant systems intended to provide appropriate safety margins in the event of normal system or component failure. Given the impact of water on sensitive electronics, and the increasingly sophisticated electronic environment in current commercial aircraft, the incorporation of a water spray system introduces a potential common cause failure source. The remedy for this is straightforward but costly: components and systems in present day aircraft must be redesigned and/or relocated to eliminate water as a common cause failure source. Various types of protective measures are certainly possible. In order to provide adequate protection to critical components and systems, however, the cost would be considerable.

A recent Civil Aviation Authority (CAA) paper, titled "Air safety regulation and its commercial impact" (Reference 11), published in the Aeronautical Journal, March, 1991, quoted figures of between £77,000 (\$147,500) and £106,000 (\$203,000) per aircraft for the installed cost of a cabin water spray system, and weight penalties of 650 to 1100 lb. What was not clear was the type of aircraft included in these analyses, whether they address new designs or retrofit, and what will be required to "waterproof" critical systems to make them invulnerable to common cause failure. Not included in these CAA figures is the cost impact to the aircraft operator for both operational and maintenance costs, all of which are ultimately passed on to the flying passenger.

In order to fully understand the impact of installation of a cabin water spray system, Boeing has prepared detailed design and cost analyses for the "SAVE" system installed in a new 777 aircraft. We believe the unit cost, based on 1992 dollars, to be \$1.2 million for design and installation, exclusive of the protection required for other, water-sensitive systems. Using this analysis as a baseline, estimates for the other aircraft in the Boeing family range from \$1.7 million for the 747-400, to \$530 thousand for the 737, for new construction aircraft. These figures do not consider the case of retrofit installations in existing aircraft, which would be higher. (Additional detail is available in the Aerospace Industries Association report on "Cabin Water Spray Systems for Post Crash Fire Protection", dated December, 1992). Weight estimates for each of the study aircraft incorporating a water spray system have also been prepared, based on the same design analysis. Unlike the optimistic CAA figures, these weight estimates range from 766 lb for a 737-300, to an extreme penalty of 3612 lb for a 747-400. All of these weight figures are based upon the SAVE system precipitation rate of 0.03-inches per minute for 3-minutes, and the net wetted cabin area of each aircraft. Preface Table 1 provides a summary of these figures.

Preface Table 1. System Weight Impact.

	737-300	747-400	757-200	767-300	777
Water (gal)	54	247	75	120	148.3
Water (lb)	451	2062	626	1002	1238
Estimated system weight	315	1550	470	750	930
Total weight	766	3612	1096	1752	2168

Note: Precipitation rate of 0.03-inches per minute for maximum of 3-minutes
One gallon = 8.35 lb

In recognition of this severe weight penalty that the system specified by the SOW imposes on the airplane and its operator, recent efforts by the CAA and FAA have concentrated on possible methods of reducing system weight. Since the weight of the onboard water is the largest portion of the total system weight, the most promising approach is the creation of a "smart" system, by reducing the total time of spray and/or spraying only that zone where a heat or fire sensor determines that water is required. Studies conducted by the CAA indicate that a reduction in onboard stored water of $\frac{2}{3}$ might still provide 45-seconds of extra protection. This type of reduction would allow weights approximately $\frac{1}{2}$ of those indicated in Preface Table 1, but the potential for saving lives with these revised amounts is unclear. Also, a "smart" system implies a level of system complexity that the SAVE system did not have, and requires that the design incorporate, at significant expense, the very high system reliability required of other safety systems and critical electronics.

Estimates of the costs per potential life saved by a number of safety improvements, both current and proposed, were presented for comparison purposes in the aforementioned paper. Using the CAA figures, the cost per (UK) life saved by a functional cabin water spray system is £9 million, or \$18 million, for UK registered aircraft. When compared to other standards used to judge the value of safety improvements, these figures appear to be high. However, as we have outlined, the CAA system weight and complexity figures seem to be very optimistic, which would make the true cost per potential life saved significantly higher than that \$18 million.

The current regulatory activity to establish Net Safety and Cost Benefit Analyses for justification of a cabin water spray system is based on a total of 88 "survivable" accidents between 1966 and 1991. A substantial portion of this group of 88 accidents involved 1st and 2nd generation commercial jet transports with documented accident rates an order of magnitude higher than those for newer generation aircraft introduced during the last 10 to 15 years (Preface Figure 1). This is significant in two respects; first, it demonstrates the tremendous improvements in accident avoidance and passenger safety achieved by newer aircraft types, and second, as the accident rate decreases, the true cost of a cabin water spray system to the airlines and the flying public again increases substantially beyond the \$18 million per (UK) life saved currently estimated. With this in mind, and with many of these early commercial jets either out of service or due to be retired before any regulation requiring the incorporation of water spray systems is mandated, it would seem appropriate to include only those recently manufactured aircraft, that would be affected by a potential rule, in the cost and safety benefit analyses. This would be the only proper course of action to determine the true relative worth of cabin water spray systems to both the current and future jet fleets.

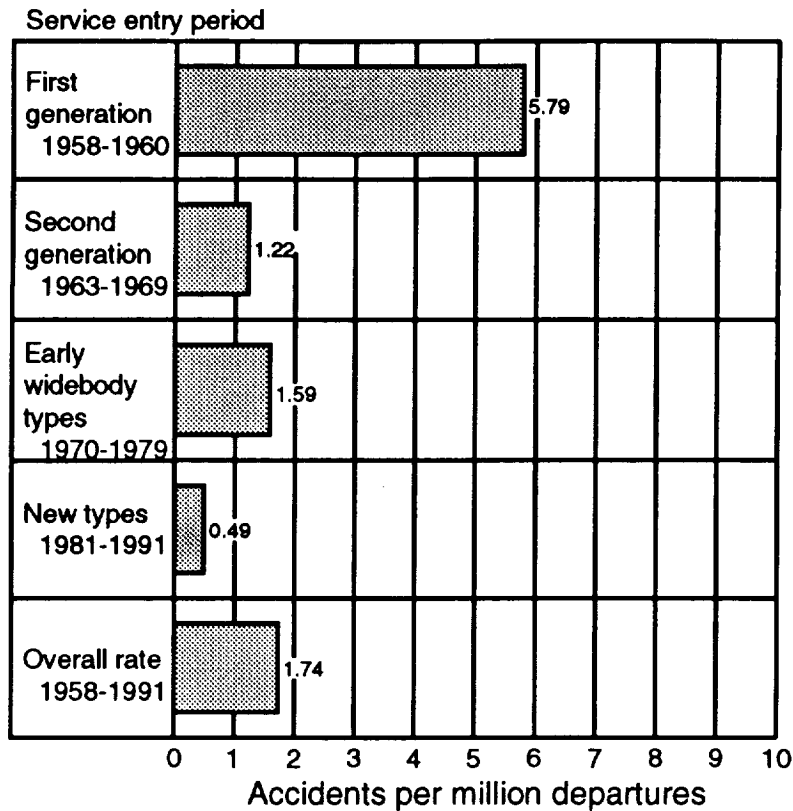

Worldwide Commercial Jet Fleet — 1958-1991

* Excludes: sabotage, military action

Preface Figure 1. Hull Loss Accident Rates*

Laboratory testing has demonstrated, in selected scenarios, that water spray systems can be effective in removing heat, delaying the onset of combustion of interior materials, and scrubbing smoke particulates from the air. However, the potential for catastrophic loss caused by inadvertent discharge, and a common cause type failure inflight, could more than offset the life saving potential of such systems. In the case of a commanded activation, in the presence of fire, the potential for slippery conditions, reduced visibility, loss of communication and potential disorientation could also create a negative safety benefit.

The net safety benefit analysis is ultimately the tool which will be used to evaluate the benefits of cabin water spray systems versus the disbenefits discussed in this report. We strongly believe that there exists a number of issues that must be addressed, either as part of that safety benefit analysis, or in further studies which should support the system evaluation programs conducted to date. These include; recent improvements in heat release and fire blocking materials which have already contributed to an increase in the time available for emergency evacuation; the impact of water on sensitive electronics, and how that impact might be minimized to assure required levels of system reliability after an inadvertent discharge; the psychological effect of water on passengers, without a fire threat; an activation sequence that is sensible and reliable without increasing pilot workload during critical segments of the flight; and the operational and logistical aspects of such systems, such as the need for freeze protection, any water quality requirements, and procedures for system test without wetting the interior of a serviceable aircraft. Only by addressing these items, and more which are certain to appear, will the true net benefits of cabin water spray systems become clear.

The outstanding, and improving, safety record achieved by the commercial jet aircraft industry over the past 35 years is a direct result of the significant strides made in aircraft and equipment design promoted by the regulatory bodies, aircraft manufacturers, and the airlines. It further indicates, in our view, that it is far more cost effective to spend limited research money on systems and procedures which keep accidents from happening, enhancing the safety of the flying public and the health of the industry in the process.

STUDY TEAM RECOGNITION

Recognition should be given to the personnel from the Functional Engineering Organizations in the Boeing Commercial Airplane Group who were the contributors to this study and for their efforts to maintain their investigation objectivity. The contribution of these organizations and individuals is gratefully acknowledged and appreciated:

Chuck Anderson	Flight Deck Research
Dennis Anderson	Product Safety
Howard Brown	Reliability and Maintainability
Ruth Clarke	Flight Controls
Alan Clifton	Payload Systems
Ray St. Cyr	Flight Controls
Janet Gaylor	Payload Systems
Lori Gilpin	Environmental Control System – Mechanical Systems
Mike Graham	Structures
Don Grimes	Payload Systems
Greg Grimstad	Payload Systems
Scott Hendren	Environmental Control System – Mechanical Systems
Barbara Jackson	Product Safety
Larry Johnson	Structures
Tim May	Flight Deck/Avionics
Mike McClosky	Electrical Systems
Alan Pham	Electrical Systems
Kent Porter	Payload Systems (Study team leader)
Don Reid	Human Factors
Tom Reynolds	Program Manager
Cathy Rider	Payload Systems
Pat Riordan	Contracts
Shiva Sarrafan	Propulsion
Lori Wade	Business Management
Mike Wisniewski	Structures
Norbert Woloszyn	Reliability and Maintainability

A special recognition and thanks to Alec Pyron, Director of Engineering, Delta Air Lines and Steve Pitner, for their dedication, invaluable assistance and evaluation of the “return to service” cost estimates for refurbishment of the 757 study aircraft.

Table of Contents

1. INTRODUCTION	1
2. BACKGROUND	1
3. SYSTEM OVERVIEW	2
4. SCOPE OF THE STUDY	3
4.1 AIRCRAFT	4
4.2 FLIGHT SCENARIOS.....	4
4.3 BASELINE STUDY REQUIREMENTS	4
4.4 APPROACH AND METHODOLOGY	5
5. FUNCTIONAL ORGANIZATION EVALUATIONS	7
5.1 PAYLOAD SYSTEMS	7
5.2 ENVIRONMENTAL CONTROL SYSTEMS.....	12
5.3 ELECTRICAL SYSTEMS	21
5.4 PROPULSION SYSTEMS	34
5.5 FLIGHT CONTROL SYSTEMS	37
5.6 STRUCTURES	40
5.7 HUMAN FACTORS.....	44
5.8 FLIGHT DECK OPERATIONS	48
5.9 PRODUCT SAFETY	52
5.10 RELIABILITY AND MAINTAINABILITY (R&M)	56
5.11 RETURN TO SERVICE.....	59
6. SUMMARY AND CONCLUSIONS	61

Appendices

APPENDIX A	DIMENSION DRAWINGS AND PRINCIPAL CHARACTERISTICS	67
APPENDIX B	STANDBY BATTERY POWER SYSTEM	77
APPENDIX C	RETURN TO SERVICE COST BREAKDOWNS	85
APPENDIX D	757-200 CONFIGURATION MEMO	111
APPENDIX E	HUMAN FACTORS – A REVIEW OF TWO SELECTED REPORTS	131

List of Figures

Preface 1	Hull Loss Accident Rates	v
3-1	Cabin Water Spray System Isometric	2
4.4-1	757-200 Passenger Configuration	5
4.4-2	757 Overhead (Attic)	6
4.4-3	757 Cross Section	6
5.1-1	Carpet Absorption Characteristics (3-Minute Spray)	8
5.1-2	Emergency Lighting	11
5.2-1	Environmental Control System	13
5.2-2	Electrical/Electronic Equipment Cooling System	13
5.2-3	757 Water Mist Paths and Quantities	14
5.2-4	Typical Passenger Cabin Airflow Patterns	15
5.2-5	Aircraft Airflow Distribution	16
5.2-6	757-200 Equipment Cooling Airflow Distribution	17
5.3-1	Forward E/E Bay	22
5.3-2	Electrical Power System	24
5.3-3	Electrical Standby Power System	26
5.3-4	Equipment Centers	27
5.3-5	Flap/Slat Electronic Unit	29
5.3-6	Proximity Switch System	30
5.6-1	757 Lower Lobe Dust Accumulations	42
5.6-2	757 Lower Lobe Dust Accumulations	43
5.9-1	767 Front View Main Electrical/Electronic Racks	53
5.9-2	767 Front View Main Electrical/Electronic Racks	54

List of Tables

Preface 1	System Weight Impact	iv
5.2-1	Mist Distribution Summary for 757 Electronics	18
5.2-2	Mist Distribution Summary for 737-300 Electronics	20
5.3-1	Electronics Misting Summary (Assume No Filtration)	25
5.11-1	Labor/Cost Summary	61

List of Acronyms

AC	advisory circular	dc	direct current
ac	alternating current	DFDAU	digital flight data acquisition unit
A/C	air-conditioning	dim	dimension
ACARS	ARINC communications addressing and reporting system	DME	distance-measuring equipment
ACE	actuator control electronics	E/E	electrical/electronic
ADC	air data computer	ECS	environmental control system
ADF	automatic direction finder	EDP	engine-driven pump
ADI	attitude direction indicator	EEC	electronic engine control
AFC	automatic flight control	EFIS	electronic flight instrument system
AFDS	autopilot flight director system	EGT	exhaust gas temperature
APB	auxiliary power breaker	EICAS	engine indication and crew alerting system
APU	auxiliary power unit	EIU	EFIS/EICAS interface unit
ARINC	Aeronautical Radio, Inc.	ELCU	electrical load control unit
ATA	Air Transport Association	eng	engine
ATC	air traffic control	EPC	external power contactor
ATP	acceptance test procedure	EPR	engine pressure ratio
aux	auxiliary	ETOPS	extended-range twin operations
BATT	battery	FAA	Federal Aviation Administration
BCAG	Boeing Commercial Airplane Group	FAATC	Federal Aviation Administration Technical Center
BCU	bus control unit	FADEC	full-authority digital electronic control
BITE	built-in test equipment	FAR	Federal Aviation Regulation
BMS	Boeing Material Specification	FCC	flight control computer
BPCU	bus power control unit	FCES	flight control electronic system
BSS	Boeing Specification Support Standard	FCU	flap control unit
BTB	bus tie breaker	FMC	flight management computer
C	center	FMCS	flight management computer system
CAA	Civil Aviation Authority (UK)	FMEA	failure modes and effects analysis
CDU	control display unit	FMECA	failure modes, effects, and criticality analysis
CIC	corrosion inhibiting compound	FMS	flight management system
cm	centimeter	F/O	First Officer
CRT	cathode ray tube	FQIS	fuel quantity indicating system
CSD	constant speed drive	FSEU	flap/slat electronics unit
CSEU	control system electronic unit	ft	foot
CWS	cabin water spray	fwd	forward
CWSS	cabin water spray system		
DAA	digital/analog adapter		

List of Acronyms (*Continued*)

gal	gallon	PDIU	propulsion discrete interface unit
GCB	generator control bus or generator circuit breaker	PDU	power drive unit
GCU	generator control unit	PFD	primary flight display
GE	General Electric	PSEU	proximity switch electronic unit
gen	generator	psi	pounds per square inch
HF	high frequency	PSU	passenger service unit
HSI	horizontal situation indicator	PTU	power transfer unit
HVPS	high voltage power supply	PW	Pratt & Whitney
Hz	hertz	R	right
ICAO	International Civil Aviation Organization	R&M	reliability and maintainability
IDG	integrated drive generator	RAT	ram air turbine
IGV	inlet guide vane	RDMI	radio distance magnetic indicator
ILS	instrument landing system	RH	right hand
in	inch	R-R	Rolls-Royce
INOP	inoperative	RTV	room temperature vulcanization
INV	inverter	SAM	stabilizer trim/elevator asymmetry module
IP	ILS panel	SELCAL	selective calling
IRS	inertial reference system	SOV	shut-off valve
IRU	inertial reference unit	SOW	statement of work
kg	kilogram	stby	standby
L	left	SWC	stall warning computer
lb	pound	TCAS	traffic alert and collision avoidance system
lbm	pounds–mass	TMC	thrust management computer
LH	left hand	T/R	thrust reverser
LRU	line-replaceable unit	TRU	transformer/rectifier unit
m	meter	UCM	uncommanded motion
MCDP	maintenance control and display panel	UK	United Kingdom
MCP	mode control panel	US	United States
MEL	minimum equipment list	V	volt
min	minute	VHF	very high frequency
N ₁	rotor assembly number	VMC	visual meteorological conditions
NASA	National Aeronautics and Space Administration	VOR	VHF omnidirectional range
ND	navigation display	WXR	weather radar
PA	passenger address		
PC	printed circuit		

PAGE ~~XII~~ INTENTIONALLY BLANK

Executive Summary

A "proof of concept" on-board cabin water spray system has been developed that has demonstrated the ability to suppress aircraft cabin fires. The motivation for this development was the 1985 British Airtours, Manchester accident. This accident resulted in the loss of 55 lives following an uncontained engine failure that punctured a wing fuel tank while the aircraft was on its takeoff roll.

The successful demonstration prompted the Civil Aviation Authority (CAA) to conduct further testing that was documented in CAA paper 88014 "Aircraft cabin fire suppression by means of an interior water spray system." Subsequent full-scale fire tests conducted by the Federal Aviation Administration Technical Center (FAATC) and various CAA facilities at Teeside and Cardington have demonstrated that a cabin water spray mist system is effective in preventing the early onset of combustion of cabin interior materials, and removing heat and smoke particulates from the passenger cabin in fire test scenarios.

In order to obtain a balanced opinion on the benefits of cabin water spray systems (CWSS), the National Aeronautics and Space Administration (NASA) and the Federal Aviation Administration requested Boeing Commercial Airplane Group (BCAG) to investigate the potential disadvantages or "disbenefits" of CWSS and its effect on the aircraft. This study is part of a cost sharing contract agreement between BCAG, FAATC, Atlantic City, New Jersey, and NASA-Langley Research Center, Hampton, Virginia to investigate the "disbenefits" of installing a "SAVE" Ltd. cabin water spray system in current in-service and new design Boeing commercial jet aircraft.

The primary objective of the Boeing study was to investigate the implications of the activation (commanded and uncommanded) of a CWSS on various models of Boeing aircraft, and to identify and quantify the potential "disbenefits" that might exist under various operating conditions. All key aircraft functional areas have been reviewed for potential damage and consequences. Significant concerns regarding overall aircraft safety and the basic economics of cabin water spray (CWS) systems have been identified and discussed within the body of this report. The cost of returning an aircraft to service following an inadvertent discharge was investigated with assistance from Delta Air Lines.

Summarizing our key conclusions from this study:

- CWS is a safety system that can negatively affect other key safety of flight systems, by creating a common cause failure source;
- Flight and evacuation critical systems will require detail review and potential major redesign to mitigate water damage;
- CWS may increase evacuation time;
- Evacuation into and prolonged exposure to a cold climate following discharge may be hazardous;
- All aircraft systems susceptible to water damage require detail review to minimize damage and return to service costs;
- The cost of returning an aircraft to revenue service following discharge is high;
- Passenger reactions to activation of water spray are unknown.

PRECEDING PAGE BLANK NOT FILMED

All key aircraft functional areas have been reviewed and appropriate recommendations presented for further study. The overall system reliability will require further assessment with the introduction of water as a possible failure mechanism on redundant systems. A net safety benefit analysis should include the potential effects of slowing passenger egress during evacuation.

1. INTRODUCTION

The potential for improved survivability of a serious aircraft accident involving fire may be realized by the incorporation of a proposed cabin water spray safety system that has been tested by regulatory agencies in the United States (US) and the United Kingdom (UK). A prototype aircraft cabin water spray has demonstrated the ability to suppress fire in the passenger cabin which can result from a post-incident fuel-fed fire spreading rapidly to interior furnishings. The promising results of early testing have been published by the Civil Aviation Authority (CAA) (Reference 1), resulting in the pursuit of joint research programs by the CAA and the Federal Aviation Administration (FAA). A second, more thorough round of testing has now been completed by those agencies, and has confirmed the positive aspects of such a system.

In order to obtain a balanced opinion of the advantages versus disbenefits (disadvantages) of an onboard water spray system, the National Aeronautics and Space Administration (NASA) and the FAA requested the Boeing Commercial Airplane Group (BCAG) to investigate the potential disbenefits of this type of system, from the perspective of the aircraft manufacturer and the operator. The effects on a modern commercial jet aircraft that might result from a water spray discharge have been evaluated for the following cases: the case of inadvertent operation in taxi, takeoff, cruise, and landing modes, and the case of intentional operation while the aircraft is on the ground, including possible effects on passenger evacuation. The difficulties and costs associated with returning an aircraft to service following discharge, without the presence of fire, have been addressed.

2. BACKGROUND

The concept of utilizing a cabin water spray system (CWSS) as a means of increasing passenger survivability following an accident involving an external fire has its roots in the British Airtours Manchester, UK disaster of 1985. This accident, resulting in the loss of 55 lives, was caused when fragments from an uncontained engine failure pierced a fuel tank while the aircraft was on its takeoff roll. Fuel spilled onto the hot engine, ignited, and produced thick black smoke which rapidly entered the passenger cabin through the right rear door, which had been opened by a flight attendant before the aircraft stopped. Fire subsequently entered the cabin, with furnishings becoming rapidly involved, creating an environment of thick smoke, toxic gases, and intense heat.

This accident was witnessed by the late Jim Steel, founder of SAVE Ltd., who theorized that an onboard water spray system, similar to that used in commercial buildings, might have provided enough protection to passengers to allow extra evacuation time and prevent an accident like this from turning into a disaster. The cabin water spray system conceived by SAVE Ltd. was first demonstrated to the CAA in 1987, in a VC-10 fuselage. This demonstration was successful enough that a test program was authorized.

As a result of the initial demonstration of the SAVE Ltd. system, and subsequent testing by the CAA, the airworthiness authorities in both North America and Europe initiated a collaborative research and development program involving aircraft manufacturers and industry. System testing was conducted by the Federal Aviation Administration Technical Center (FAATC), located in Atlantic City, New Jersey, and by the CAA at the Fire Research Station in Borehamwood, and at its Cranfield and Cardington facilities. The objective of these testing programs was to determine scientifically the benefits provided by a cabin water spray system, and how a system might be best configured to provide the maximum benefit. Laboratory testing preceded the full scale testing, with efforts concentrating on three effects: atmospheric treatment, where the products of combustion are washed from the air; surface cooling, which delays combustion and the production of smoke and toxic gas; and cabin cooling, which keeps the temperatures in the cabin to a survivable level. Full scale testing followed, with both the CAA and FAA using fuselage sections of production aircraft for a series of fire tests, where jet fuel "pan type" fires were lit under controlled conditions. These sections were equipped with production materials

and furnishings, and the interiors were instrumented for temperature and gas readings. Initial results from this round of testing indicated that water spray inhibits the ability of the furnishings to become involved in the fire early in its development, and reduces the cabin temperature to a survivable level. This alone, in the critical stages of a fire, provides additional critical minutes for passenger evacuation. As a second benefit, many of the products of combustion are washed from the air, and the level of water soluble gases is reduced.

Following the initial capability demonstrations by SAVE Ltd. and the CAA, several companies in the UK began programs aimed at the development of water spray systems and components that could be integrated into, and function in, an aircraft environment. These companies have evaluated multiple combinations of nozzle geometry and location to establish system configurations that would maximize the effectiveness of water application (quantity and rate), and minimize the amount of water required to be carried on board each type of aircraft. Additional tests considered different system types: British Petroleum's "water curtain" approach, and AIM Aviation's modular system, designed to assure maximum survivability in a crash, and provide for easy retrofit of existing aircraft. Both Darchem Engineering Ltd. and Walter-Kidde (Fire and Safety International) have concentrated on improvement and optimization of the original SAVE Ltd. system. While each of these approaches have their respective advantages, none have been evaluated by an industry or regulatory standard.

During early 1988, following the initial demonstration of the SAVE Ltd. "proof-of-concept" cabin water spray system to the CAA, and its report on BBC Television, BCAG, responding to a request from a major European airline customer, initiated a preliminary concept design study of a cabin water spray system for a 737 aircraft. After several high level management discussions with this customer, it was determined that the best approach to establish a net safety benefit of water spray systems was for BCAG to support the collaborative study effort being defined and initiated by the airworthiness authorities in both Europe and North America. This study is the result of a cost sharing contract agreement between BCAG, the FAATC, and the NASA-Langley Research Center, to investigate the "disbenefits" or disadvantages of installing a SAVE Ltd. type cabin water spray system in Boeing built commercial jet aircraft.

3. SYSTEM OVERVIEW

As originally conceived, the SAVE system used a two tiered approach to cabin water spray (Figure 3-1). For the first tier, a dedicated water supply is carried aboard the aircraft, in tanks located strategically to ensure water is available even in the case of aircraft break-up. Pipes run the length of the aircraft (behind trim panels), connecting the water tanks to multiple spray nozzles located in the overhead. In its original configuration, only centerline "misting" nozzles were proposed, the water fed to these nozzles being pumped from tanks mounted remotely.

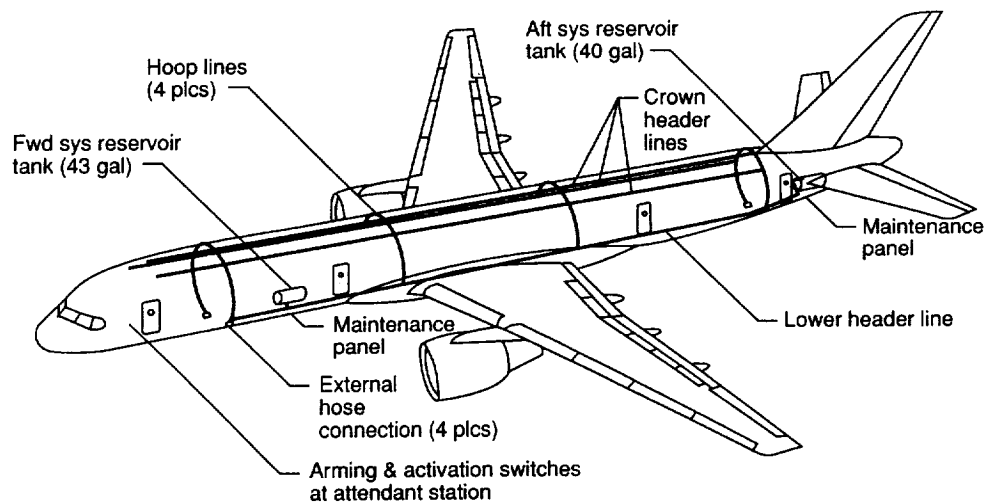

Figure 3-1. Cabin Water Spray System Isometric.

In the second tier, additional rows of nozzles, located outboard at the bin/sidewall interface, were reserved for use as a "deluge" system. This portion of the system was intended for use only upon connection of an outside, tender carried water supply, whereupon large quantities of water at very high flow rates could be pumped into the aircraft quickly. The key to this tender system was a series of external connections in the aircraft's skin, which would accept a nozzle of internationally standardized design, and would accept this high water flow upon tender arrival. Thus the onboard water supply would serve to provide several critical minutes of protection until the tender could arrive at the scene.

Following preliminary system definition, it became apparent that, in order to achieve the proper wetted area and gain the maximum time advantage for evacuation of a burning aircraft, all nozzles should accommodate both flow rates. The tender idea was retained, but all nozzles would be used for the 3-minute misting of the cabin for evacuation, followed by tender hook-up and deluge.

The original "pumping" of water from the onboard tanks was superseded by later concepts which appear more promising. These involve either a nitrogen bottle mounted alongside the water tank, pressurized to 3000 psi, which would in turn pressurize the water tank when activated, or a pyro-technic device that would pressurize the water tank not unlike an automotive air bag. Both systems would include a dump valve that could be energized to depressurize the entire system in the event of inadvertent activation.

All system concepts would utilize flexible piping to connect the overhead piping to the spray nozzle array. All piping would be dry in the inactive condition, with light blow-off caps on the spray nozzles to prevent accumulation of debris and dust which might decrease nozzle efficiency upon system activation.

Various arming and activation schemes have been suggested, with current thinking centered around the idea of the system being armed by the flight crew, probably as a pre-flight checklist item, and disarmed after climb out, to prevent inflight activation. System activation could be initiated in a number of ways. It must be recognized that the arm/disarm/activation/dump scheme is a significant consideration in the design of a "real" system, such that the possibility of inadvertent activation is "highly improbable".

4. SCOPE OF THE STUDY

The study was designed as a broad, wide-ranging investigation into the potential disadvantages of water spray on aircraft systems and emergency evacuation of a wetted aircraft. The investigation considered the implications of the activation of a cabin water spray system on various models of its Boeing jetliner aircraft, with the 757-200 serving as the baseline/focus airplane.

A 757-200 was "configured" with the "SAVE" cabin water spray system specified in the contract Statement of Work (SOW) to assess the impact of installation, and is included for reference in Appendix D. This configuration was established to estimate approximate sizing criteria and does not consider the installation impact of CWS on other aircraft systems, furnishings, interiors, wiring, etc.

Early in the study, it was decided that the 727 would not be included in the scope. This decision was made for two reasons. First, since the 727 is not currently in production, all information regarding its systems and construction details would have to be pursued through a small, post-production engineering organization. This would have made any investigation into water paths, materials, and protective measures much more difficult than for current production aircraft. Second, and perhaps more importantly, considering time required for the issuance of a Federal Aviation Regulation (FAR), the 727 would likely be nearing the end of its useful life due to Phase III noise standards, and might not be included in any regulatory action. A similar reasoning was used with the 707, which is also excluded from this study.

4.1 AIRCRAFT

All current production models were considered in the investigation and include 737, 747, 757 (4-Door), 767, and 777 where appropriate. Although the SOW called for attention to individual dash numbers (e.g. 737-200, etc.), once the study began, it became clear that no particular advantage was to be gained by this approach. As will be discussed in greater detail later in this report, a dash number specific approach implies a much finer "resolution" of predicted water paths than was found possible. Dimension drawings for each type aircraft considered are included in this report as Appendix A.

4.2 FLIGHT SCENARIOS

The Statement of Work required the following scenarios be used to facilitate the identification of the disbenefits:

In the ground activation scenario the study aircraft were investigated to establish the disbenefits for two distinctly different cases:

- Case I: (Design Case) is the commanded activation of the CWSS in the presence of a severe fire external to the aircraft;
- Case II: The inadvertent or uncommanded activation of the CWSS while the aircraft is on the ground but in a taxi, takeoff, or landing mode.

In the airborne activation scenario the aircraft systems and controls were investigated to establish those parameters and conditions that would adversely affect safety-of-flight and passenger safety in general. Level flight at cruise altitude, takeoff, climb, and landing approach (high flight crew workload) were considered.

The study also addressed the cost of returning the aircraft to service following the precautionary use or uncommanded activation of the CWSS in the circumstance where the aircraft has not been damaged by fire. Delta Air Lines was brought into the study team as a subcontractor to develop the primary cost data for this part of the study, and has provided valuable insight in the preparation of this report. Boeing personnel assisted the subcontractor in developing baseline data, and provided consultation as required during the course of this study.

4.3 BASELINE STUDY REQUIREMENTS

The cabin water spray system used as the baseline for this study was based on the SAVE Ltd. system developed and initially tested in the UK. The system concept specified assumes a uniform spray distribution pattern over the passenger cabin floor area, and a precipitation rate of 0.8 mm (0.03-inches) per minute for a maximum of 3-minutes. The use of additives, biocides and freeze protection chemicals was not considered part of the study.

The study concentrated on the spraying of the passenger compartment, including galley areas and above ceiling panels (Section 4.4). Three areas were specifically identified in the SOW as "non-spray" areas following initial technical discussions with the Payloads, Structures and Product Development organizations within BCAG. These areas are the cargo compartment, underfloor, and cheek areas, and were specifically excluded from consideration due to the design of the structures, attachment of cargo liners and insulation, and the small likelihood that any water spray could be directed into these areas.

4.4 APPROACH AND METHODOLOGY

The 757-200 (4-Door) model, Figure 4.4-1 and Appendix A, was selected to establish "baseline" disbenefits that were to be studied in further detail. All other models would be studied, with only those specific differences to the baseline reported.

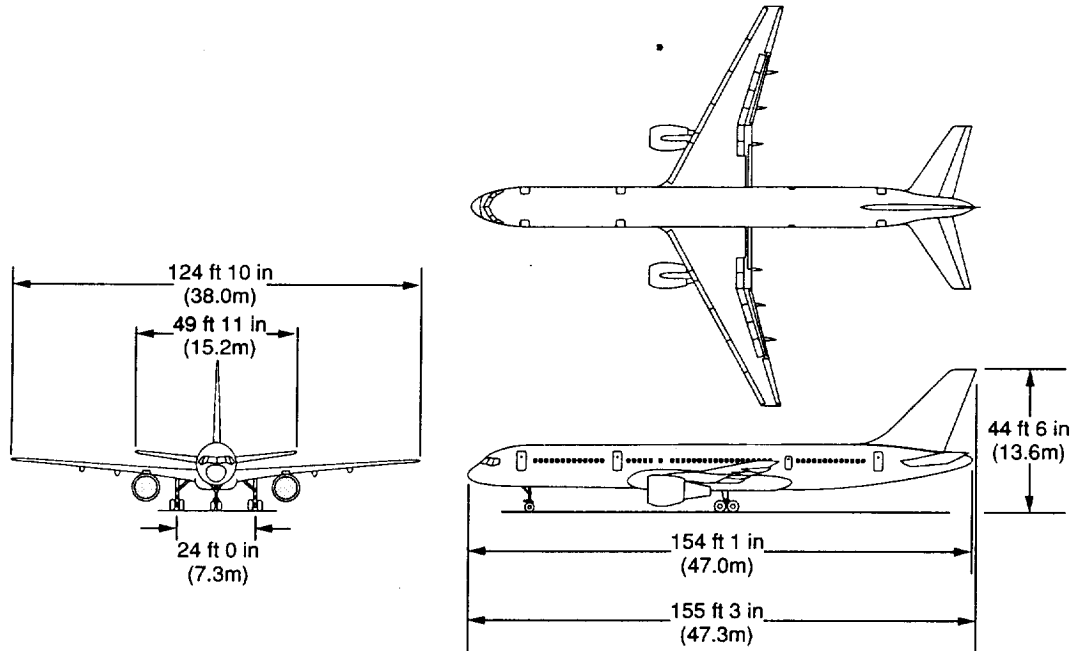

Figure 4.4-1. 757-200 Passenger Configuration.

During early study team discussions, and in preliminary investigative work, it became apparent that water paths, following spray activation, would be extremely difficult to predict reliably. Water paths, it was concluded, would be subject to too many variables, including airline specific configuration, environmental control system (ECS) status during discharge, absorptive characteristics of cabin materials, passenger count, airplane attitude, and even, to a degree, on random probability. This conclusion does not affect that part of the water that finds its way to the electrical/electronic (E/E) bay via the E/E cooling system, which is discussed in Section 5.2. This approach acknowledges that water paths and quantities for that portion of the total water sprayed in the passenger cabin that leaks through floor panels into the lower areas of the airplane is impossible to predict analytically. This fact forced the study into a much more "generic" direction, equipment being studied for the presence of water, rather than a specific quantity. It also meant that many equipment items that might in reality see no water following the spray event would be reviewed, at least in a broad sense, for any damage that water might create.

Consideration given to spraying above ceiling panels was also approached generically. This spray requirement would prove particularly difficult, as demonstrated by Figures 4.4-2 and 4.4-3. Space above the ceiling panels on the standard body airplanes (737, 757) is extremely limited, and it would be very difficult to install the piping and nozzles required for cabin water spray. Also, this space limitation would not allow a proper spray pattern to develop, and would expose overhead mounted components to direct spray, with little absorbent material for protection. As a result, overhead mounted components were also studied for behavior in the presence of water, but not a specific amount. The value of spray in these areas should be reviewed.

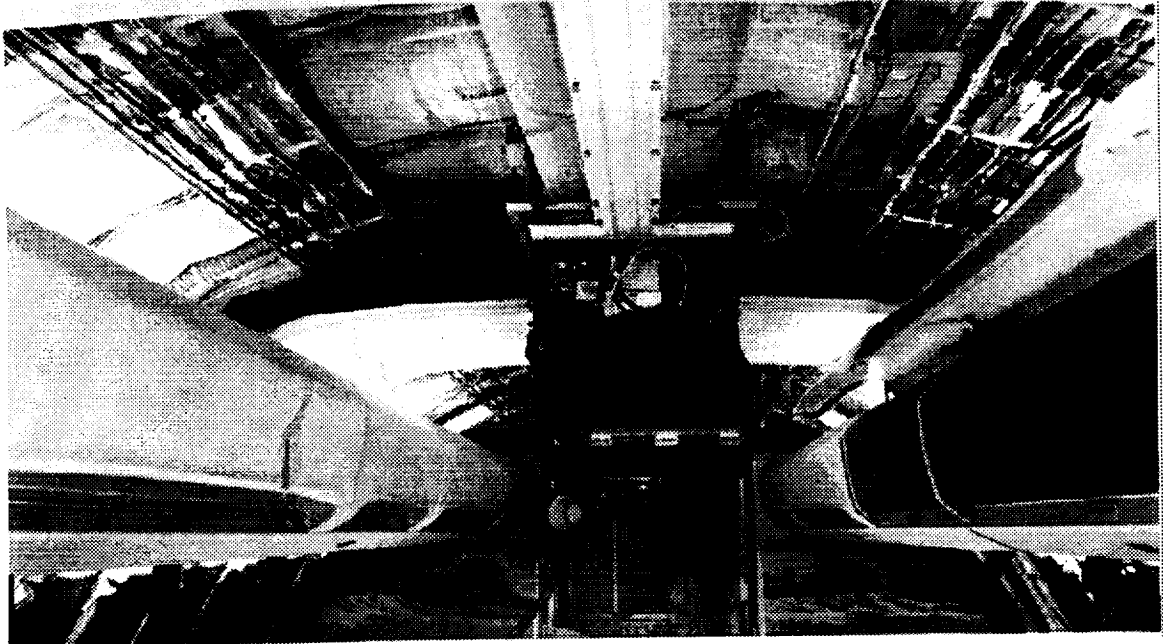

Figure 4.4-2. 757 Overhead (Attic).

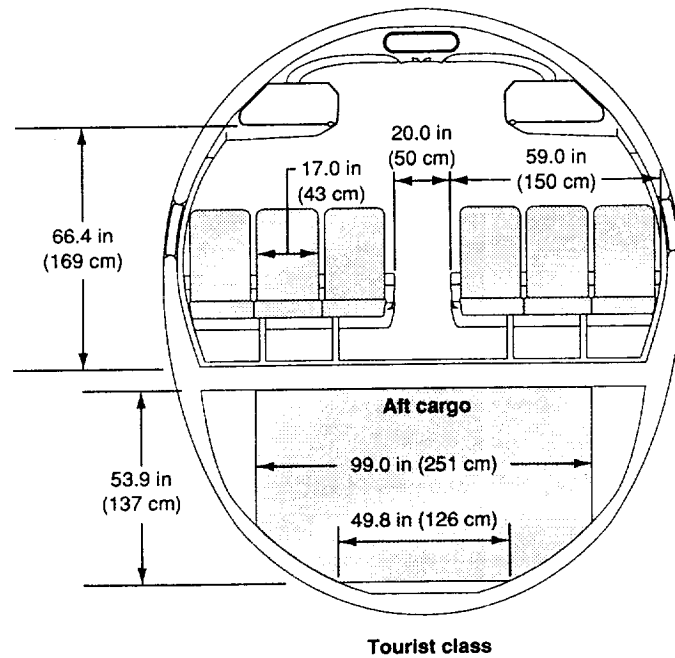

Figure 4.4-3. 757 Cross Section.

The ingestion of water mist by the ECS was the only portion of this study for which a truly analytical method could be used. While assumptions must still be made for this analysis, a specific water quantity that arrives in the E/E bay via the blow-through equipment cooling was established analytically. The evaluation of selected electronics was made on a worst case basis; that is, all equipment in the bay was considered at risk of damage, and the assessment of failure potential evaluated accordingly. Only an extensive test program, with a fully equipped airplane, will allow more definitive information for separating areas of greater damage potential from lesser ones.

5. FUNCTIONAL ORGANIZATION EVALUATIONS

In order to assess the implications of a cabin water spray discharge within the pressurized fuselage, and to identify the disbenefits that such a discharge creates, the baseline aircraft (757-200) was evaluated according to the responsibilities of the major functional organizations, guided by the affected Air Transport Association (ATA) system designators. Representatives from each of the BCAG functional engineering groups (Payloads, Environmental Controls, Electrical Systems, etc.) were tasked with evaluating the magnitude of the damage or "disbenefits" that might be incurred, and identifying design solutions or approaches that might mitigate these disbenefits.

Product Safety and Reliability Groups (Section 5.9 and 5.10) provided evaluations that considered the relationships between functional specific systems, and the overall effects of cabin water spray on the safety of the airplane and its occupants.

Study activity was initiated according to the parameters and requirements specified in the SOW. Each of the other organizations assessed the expected consequences of the CWSS discharge and conducted their investigations as conditions were identified. Summaries of these investigations were collected for Delta Air Lines cost analysis and are presented in the following sections.

5.1 PAYLOAD SYSTEMS

The design and integration of cabin water spray systems is under the functional responsibility of Payloads Systems. This portion of the study was conducted to quantify the water/mist effects on traditional Payloads components for the quantity of water that might be expected to be applied during a system discharge. Consideration has been given to both commanded and uncommanded events, with the commanded or design event considering effects of water on passenger emergency egress only. All items considered in this evaluation apply to all models, as specific differences in the Payloads components are subtle, and will generally not affect overall conclusions, except as noted.

5.1.1 Assumptions

In order to be assured of a conservative approach, and to satisfy contractual obligations, certain assumptions were required to be made.

First, the full duration of water spray was required to be 3-minutes. This time corresponds to an International Civil Aviation Organization (ICAO) agreement for fire and rescue vehicles to respond to an on field accident. For inadvertent or uncommanded operation, consideration was given to artificially limiting the spray duration, to 30-seconds or so, as it was thought that a manual shutoff could be performed within that time period. Service experience has shown that 30-seconds to be very optimistic, as several past lavatory spills have taken considerably longer to effect a shutoff. It has to be further assumed that whatever caused the system to discharge inadvertently might also prevent its early shutoff.

Second, for Payloads, the worst case occurs when the left recirculation fan is off when water is first discharged. This assures minimal ingestion of water by ECS, thus all water is assumed to be sprayed on cabin furnishings and passengers. This amounts to approximately 80 US gallons in a 757, based on the specified precipitation rate of 0.03-inches per minute for 3-minutes, water being sprayed in droplets of approximately 80-150 microns in diameter.

Third, "some" quantity of water is assumed to be sprayed directly into the airplanes overhead, above the ceiling panels. This requirement was specified as part of the system design in the contract SOW. It became apparent very early in the study that, for the standard body airplanes, this was not only impractical but physically impossible given the limited space above the ceiling panels. Some consideration was given to this case, but specific conclusions cannot be drawn as water paths would be very difficult to predict with any degree of certainty.

Fourth, in order to define a manageable problem, wool carpeting was assumed to be installed on the cabin floor. The rationale for this comes from Boeing interior standards. Currently, only wool carpets are installed in new production aircraft. Tests performed by Darchem Engineering Ltd., Stocton-on-Tees, UK, have shown that wool is a very absorbent material (Figure 5.1-1). The absorption of water by synthetics is less clear, however, they can be counted on for little or no absorbency. This makes the impact of CWS in the retrofit market very difficult to assess, although several airlines have indicated that they install only wool carpets when refitting following overhaul (discussed in detail in Section 5.1.3.1).

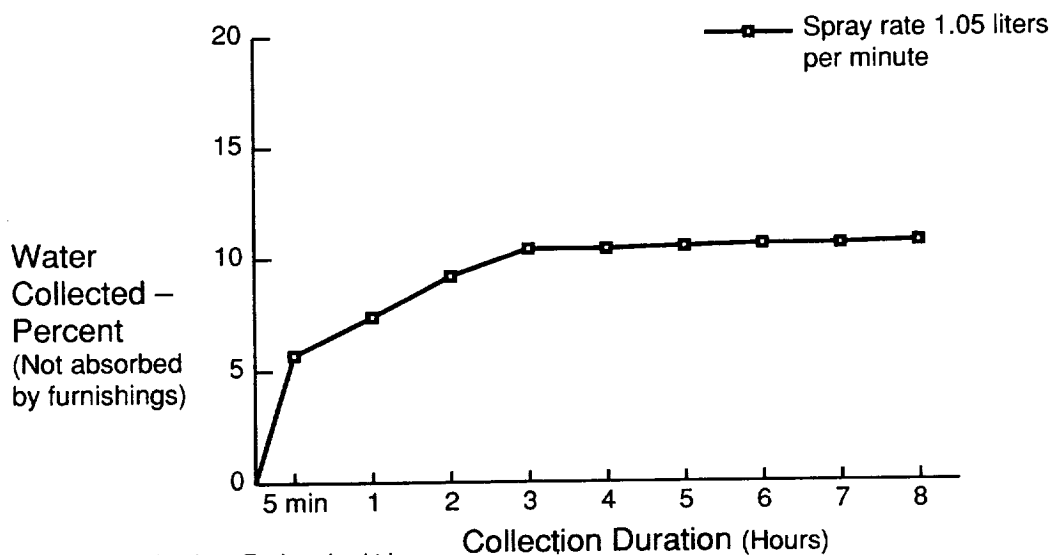

Figure 5.1-1. Carpet Absorption Characteristics (3-Minute Spray).

Lastly, the stored water used by the system is assumed to be clean and additive free, with demineralized water being preferable. This will in all probability minimize stain damage to furnishings following drying, and allow these items to be re-used, but would not prevent freezing or the growth of microorganisms in the storage system.

5.1.2 Past Water Event Experience

A number of water related events were reviewed to provide some degree of information as to what damage might be created by water being sprayed over items not designed or intended to be wet. These “events” have been reported to Boeing in the form of operational service problem reports and, although not usually very detailed, are sufficient to provide a flavor of the types of things that might be expected during and immediately after activation of a water spray system.

Several cases of leaking lavatories on the 747 upper deck have been reported, with at least one case resulting in the discharge of approximately 45 gallons of water (airline estimate) that subsequently soaked carpet and ran into the overhead passenger service units (PSUs) on the main deck. Effects from these spills included localized loss of lighting and entertainment systems, floor proximity emergency lighting, PSU functions, overheated passenger seat wiring, wet ceiling panels and carpets, and unhappy passengers. No long term data is available on these spills, but it is assumed that sufficient reconditioning was performed that will prevent future corrosion problems.

Corrosion problems on airplanes are not new and many service reports deal with this issue. Galley and lavatory areas are traditional corrosion problem areas. Even though the amount of liquid spilled there is minor compared to what a water spray system would deposit its contribution to corrosion is still significant. Door areas which might experience rain water accumulations during airplane servicing or passenger ingress/egress are also problem areas, and indicate the type of damage that might be done by water that is left and allowed to evaporate. These reports provide strong incentive for prompt refurbishment following water spray discharge. Time could be a critical factor in preventing the initial start of corrosion if the water is contaminated.

Other types of problems that have been reported from water “events” include mold growth on door mounted slide rafts, false cargo fire indications (even from excessive humidity), and condensation accumulation that drained out of the overhead causing electrical and instrumentation anomalies. Bacterial contamination of the water is a serious concern due to the lack of standards and control in various parts of the world. This would dictate an aggressive prevention program, requiring frequent system draining and cleaning and, in all likelihood, some form of biocide in the water. Effects from this type of additive on the clean-up process (staining, electrical component corrosion, etc.) following inadvertent discharge is unknown (additional discussion on this subject is found in Section 5.7).

5.1.3 Component Evaluation

5.1.3.1 Absorption Characteristics

Following initiation of a water spray event, water will begin to be absorbed by cabin furnishings, seats and carpets, and by passenger clothing. A certain amount of shedding is expected from seats and passengers, as seats are normally treated (Scotchgard, etc.) to prevent spill damage, and passenger clothing will be entirely dependent on season and fabric type (natural or synthetic). The degree of shedding from the seats is also variable, dependent on the age of the treatment. In any event, most water will most certainly find its way to the floor, and a very absorbent wool carpet.

A water absorption test was performed by Darchem Engineering Ltd., to quantify the amount of water which might be absorbed following a 3-minute water spray. Worn wool carpeting used in the test was provided to Darchem by British Airways. This carpet was tested in their cabin water spray test chamber (no seats installed), equipped with a steel grid floor, and under floor drains and collection points, over which the carpeting was installed. The water spray system was set-up to spray at specified application rates, and allowed to run for 3-minutes. Water was collected over the next eight hours.

For the flow rate of 1.05 liter/minute, only 10% of the sprayed water was collected in that time period (Figure 5.1-1). Assuming an additional 10% trapped in the collection piping, it is clear that the carpet will entrap a very large percentage (up to 80%). For conservatism, a 70% absorption was considered for this study (Section 5.2.1). This number is significant, and indicates a high probability that water “flooding” through the floor panels into the lower lobe, and towards the front of the cabin onto the flight deck will not occur, although a certain amount can be expected to be “squeezed out” of the carpet by passenger traffic, ultimately dripping through seams in floor panels. While certainly not definitive data, these results do seem to indicate that water passing beyond the passenger cabin might be manageable, and should be verified by further testing. How water in the carpet might affect an emergency evacuation is discussed in Section 5.1.3.2.

5.1.3.2 Evacuation Consideration

Significant quantities of water in and on the cabin carpeting might have the effect of slowing down evacuation (leather soles on wet wool = no traction), however, no information is available to accurately gauge the effect. The evacuation difficulties would be further compounded if the aircraft was not in a level condition, i.e., a collapsed landing gear.

Delay in the evacuation can have an adverse effect on the net safety benefits of CWS. If the fire penetrates the cabin, passengers will be exposed to a rapid buildup of toxic gases, smoke and high temperatures. An external fire that does not penetrate the cabin can affect evacuation in other ways. The incident involving a Continental DC-10 at Los Angeles in March of 1978 is a good example. In this accident, the external fire did not immediately threaten occupants, but the radiant heat from the fire rendered the available escape slides unusable before the evacuation was completed. The resulting two fatalities (and another two some months later) would most certainly have been greater had the evacuation taken any longer than it did.

5.1.3.3 Overhead Crown Area Spray Nozzles

For the case where nozzles are installed above the ceiling panels, the exact water paths would be very difficult to predict, as water will flow over the back side of these ceiling panels. Panels constructed with open, crushed-core honeycomb type backs would entrap and hold some water. Sidewall insulation blankets would likely be soaked, and water (most likely as large droplets or rivulets) would run into and around PSUs, past fluorescent lighting fixtures, reading lights and speakers in the PSUs. As currently configured, fluorescent fixtures and reading lights would likely experience electrical shorting. Halogen type lamps may explode, although these are contained and should pose no hazard. NO SMOKING/FASTEN SEAT BELT signs would likely stop working, as would the PA system, including the cabin interphone. This would obviously make emergency instructions difficult to communicate, and cabin attendant/flight crew communication virtually impossible at a time when this is vital. The emergency oxygen system is not considered to be particularly vulnerable, although those models with electrically unlatched mask drop doors (on at least all models with chemical oxygen) might be compromised. All the items listed here are also somewhat vulnerable from the in-cabin misting, but the direct spray above the ceiling would most certainly exacerbate this problem.

5.1.3.4 Cabin Lighting

The failure of electrical equipment in the passenger cabin (discussed in Section 5.3) will have several ramifications from a passenger perspective. First, loss of lighting would be very alarming under the best of circumstances, that being the case of inadvertent (no fire hazard) discharge. In an actual fire emergency, it could be life threatening. Even a partial lighting loss, combined with at least a partial loss of PA system, could result in longer evacuation times than would be required otherwise, and the full benefits of water spray would not be realized. In the very best of circumstances, only a few lights might be lost due to redundant circuitry, but there would in all likelihood be visible smoke from the shorted units. Service experience has shown that floor proximity lights (Figure 5.1-2), required for emergency evacuation, would likely not work very long after water spray, as galley spills have demonstrated. Emergency lights and exit signs are better protected, but are not currently constructed for exposure to a water-laden atmosphere.

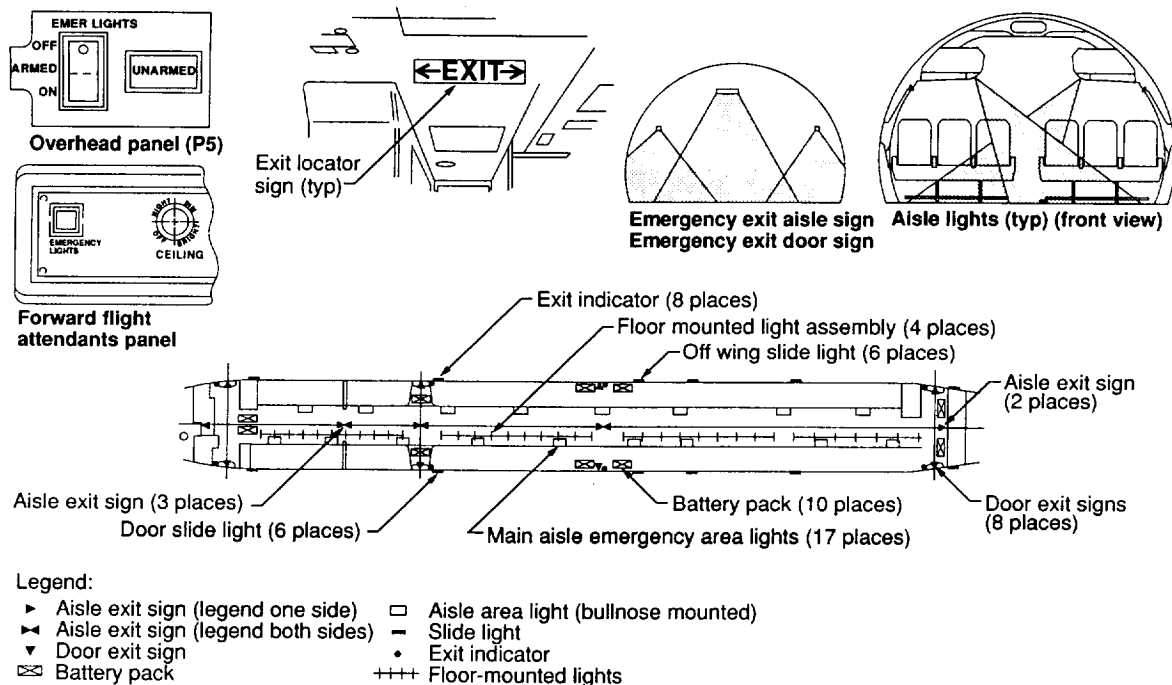

All lights and other electrical equipment which have not failed should be removed, dried, cleaned, and tested. The potential for moisture contamination in some of these units dictates a conservative approach. Manufacturers of this type of equipment have suggested this procedure as being in the best interests of the airline, minimizing the number of "repeat visits" to remedy a condition that might not have occurred at all. Shorted units will need to be replaced at this time as well. In most cases, units that were not "on" at the time they were wet will function properly following reconditioning, while those that were may need to be replaced. Note that, while the next generation components of onboard video systems of at least one manufacturer are provided with a conformal coating, the current generation are not. This is acceptable since video systems are not a "critical" item, but certainly contributes to the cost of refurbishment.

To prevent structural problems resulting from corrosion, all insulation blankets should be removed from the airplane to dry out any moisture trapped behind them. This is especially true when considering the case of additional nozzles being placed in the overhead for spraying water up into the crown area of the airplane. As previously discussed, water spray in the overhead could be expected to run past the blankets and be trapped by the stringers and frames.

5.1.5 Mitigation of Disbenefits

In order to prevent major damage to the interior electrical components such as sidewall lighting and reading lights from water spray, certain steps could be taken to "harden" these items to prevent water damage. Many of the recommended steps included here will be discussed in detail in the Electrical section of this report. Briefly, conformal coatings on all circuit cards, waterproof connectors, and drip pans in appropriate places will provide some degree of additional water resistance to that currently available. A fundamental conflict exists wherein the components that are most sensitive to water also require a means to dissipate heat, thus dictating cooling vents and ducts. This type of unit cannot be sealed, and alternate "water hardening" and entrapment techniques would be required.

Specific suggestions for assuring continuous operation of certain key Payloads/Electrical units include:

- Spray above ceiling – eliminate from consideration in small body aircraft due to lack of adequate access or spray areas;
- Fluorescent lights – waterproof connectors and sealed electronic ballasts;
- Reading lights – waterproof terminals, bulb holders, and sealed housings;
- PA speakers – drip shields and waterproof connectors or sealed housing;
- Entertainment systems – conformal coatings, waterproof connectors, interconnect to switch off system when water spray is activated.

5.2 ENVIRONMENTAL CONTROL SYSTEMS

The ECS, Figure 5.2-1, was reviewed and analyzed to assess the quantity of water mist that might be expected to be ingested by the return air grilles in the passenger cabin during activation of water spray. The quantity of water ingested is significant, as water laden air is eventually routed to the E/E bay, as part of the cooling for the electronic equipment (Figure 5.2-2). Water that is ingested into the electronics components in the E/E bay may create safety-of-flight considerations as a result of the inadvertent discharge (Section 5.3 and 5.9).

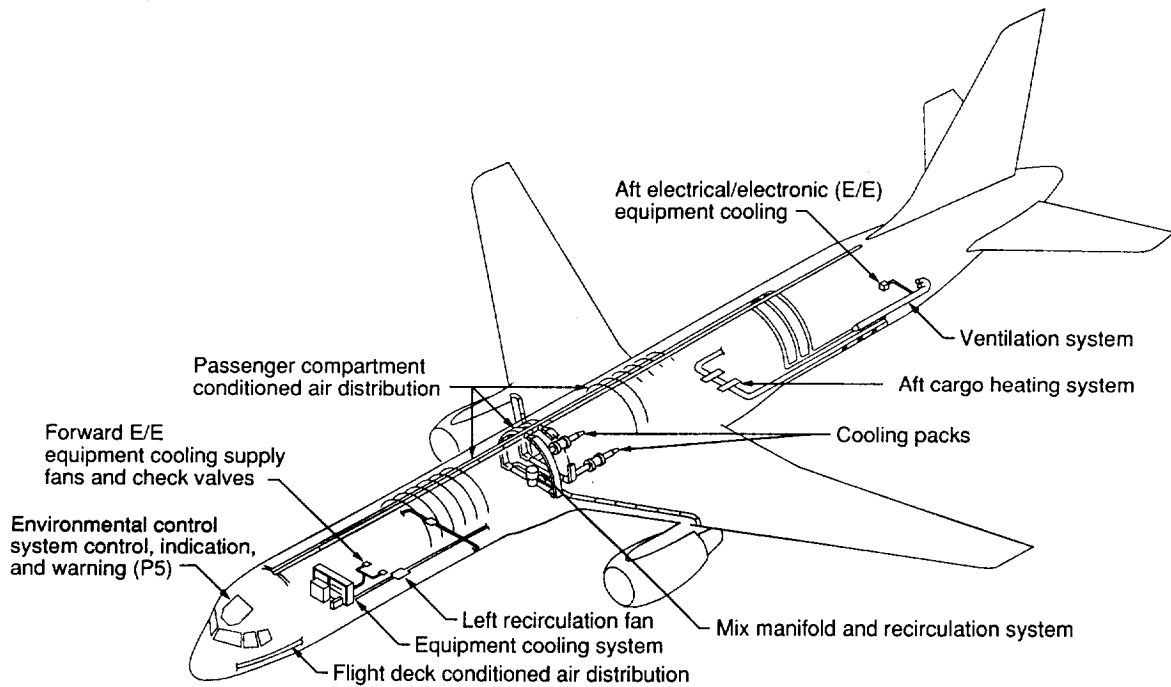

Figure 5.2-1. Environmental Control System.

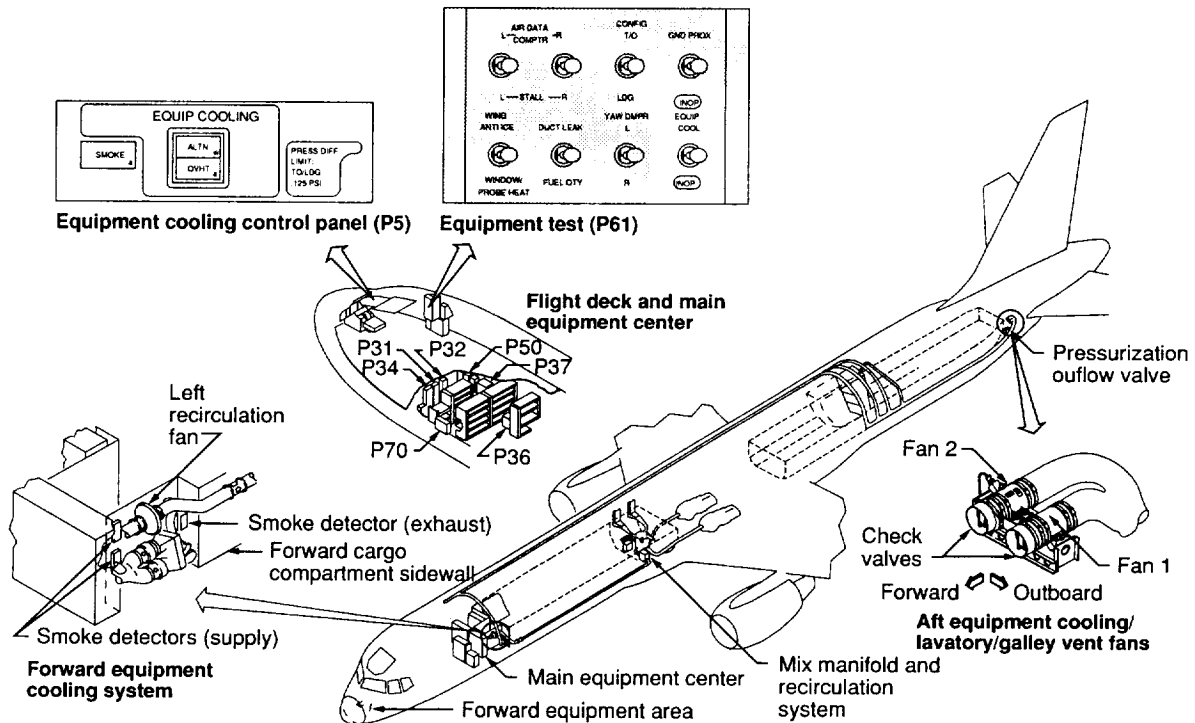
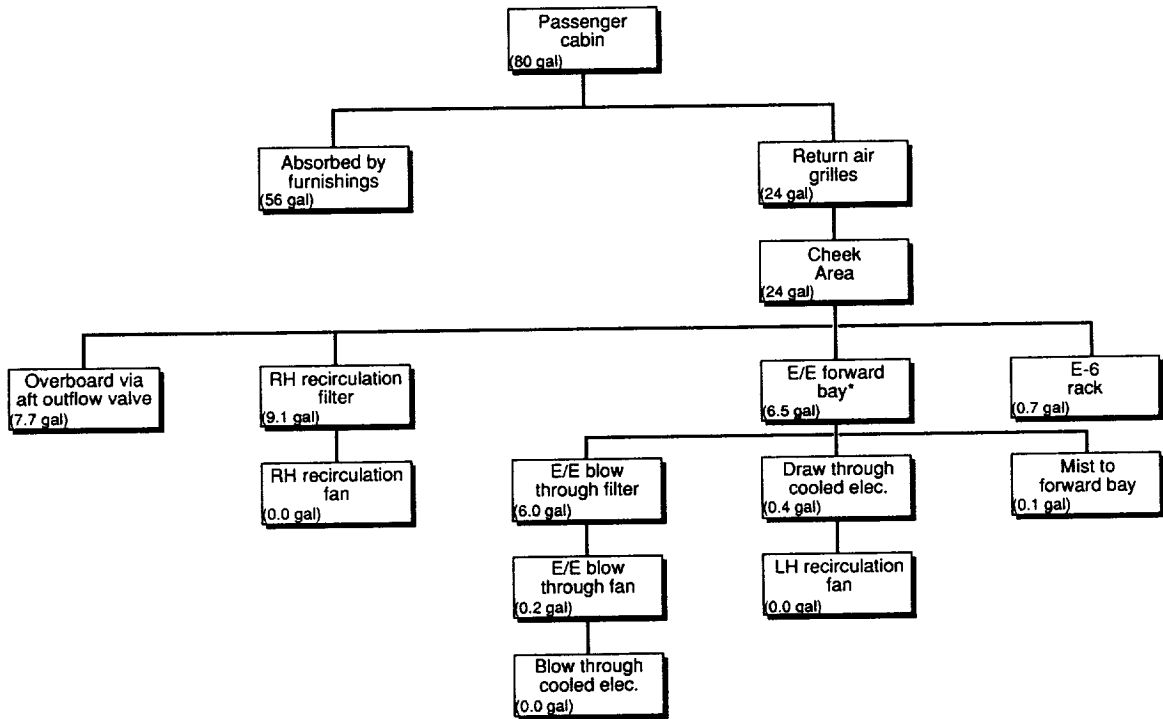

Figure 5.2-2. Electrical/Electronic Equipment Cooling System.

5.2.1 757 Water Mist Distribution

Test data and analysis indicate that the ECS will circulate water mist within the passenger cabin as well as draw mist from the passenger cabin into the lower lobe. A majority of the moisture is expected to impinge on surfaces within the passenger cabin, however, some will be drawn through the return air grilles and be distributed in the lower lobe. Figure 5.2-3 depicts the distribution and associated quantities of water expected to be drawn from the passenger cabin and into the lower lobe for the 757 baseline. Water mist will not migrate to the flight deck, due to the positive pressure differential that is maintained between flight deck and passenger cabin, when the flight deck door is kept closed as required by FAR 121.587. Regulatory agencies that allow or require that the door be left open will need to revise regulations accordingly should CWS be required on aircraft.



* Mist ingestion by electronics is estimated conservatively; i.e., mist to external surfaces may be higher than expected

Figure 5.2-3. 757 Water Mist Paths and Quantities.

ECS assessment of mist distribution within the airplane (757-200) was based on the following conditions and assumptions:

- Mist impingement on lower lobe surfaces (structure, cables, wire, etc.) was neglected when quantifying mist migration to electrical equipment in the E/E bay;
- Passenger impact on mist distribution was neglected;
- Average cabin airflow velocity of 75 ft/min (based on test data);
- Minimum droplet size of 80 microns, and droplets do not coalesce;
- A mist disbursement rate of 80 gallons over 3-minutes;
- Airplane configuration was per drawing (i.e., no broken lines);
- 39,000 foot cruise with two air-conditioning packs and two recirculation fans operating at the time of discharge;
- No mist was actively distributed to flight deck, lavatories, and galleys;
- Aircraft is carrying revenue passengers, hence flight deck door is closed as required by FAR 121.587.

Typical cabin airflow patterns are shown in Figure 5.2-4. Analysis shows that cabin airflow velocities are high enough to overcome the affects of gravity, and thus the potential for drawing mist into the lower lobe via the ECS does exist. Based on the geometry of the cabin, it was estimated that 30% of the mist would be drawn through the return air grille.

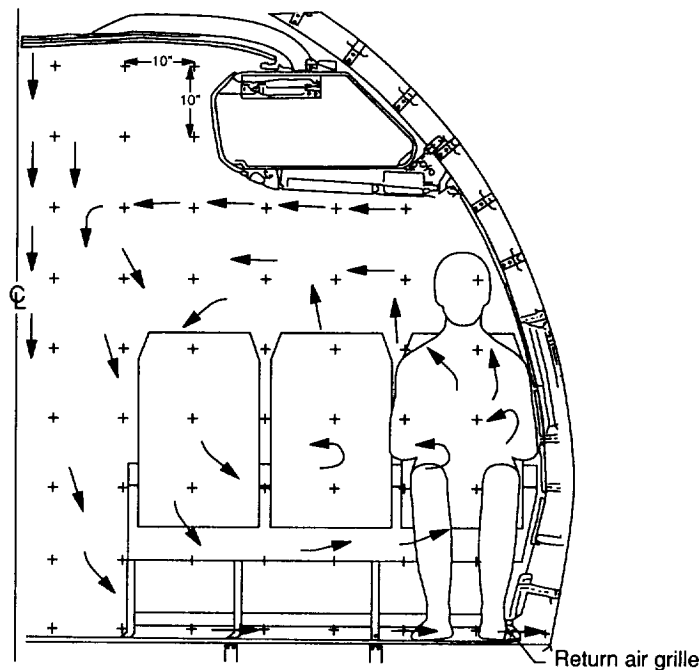

Figure 5.2-4. Typical Passenger Cabin Airflow Patterns.

Cabin air, during normal cruise operation, is drawn from the passenger cabin into the lower lobe by the right-hand recirculation fan, left-hand recirculation fan, forward equipment cooling supply fans, lavatory/galley fan, and by the pressure differential at the aft outflow valve. Air in the aft portion of the cabin is blown overboard through the aft outflow valve. A small amount of air in the aft portion of the passenger cabin is drawn through the aft bay electronics (E6 rack) by the lavatory/galley fan prior to discharge over-board via the aft outflow valve. Air in the forward section of the passenger cabin is drawn to the lower lobe by the right-hand and left-hand recirculation fans, and the forward equipment cooling supply fans. A majority of air drawn by the left-hand recirculation fan provides draw through cooling to the electronics prior to being drawn through the fan and into the mix bay. Air drawn by the forward equipment cooling supply fans provide cooling to the blow-through cooled electronics prior to being recirculated by the left-hand recirculation fan. Air drawn by the right-hand recirculation fan is used for cabin ventilation purposes only and is directly drawn from the cabin to the mix bay for reconditioning. Figure 5.2-5 depicts the test data airflow distribution for the entire airplane. Figure 5.2-6 shows airflow distribution in the E/E bay for equipment cooling.

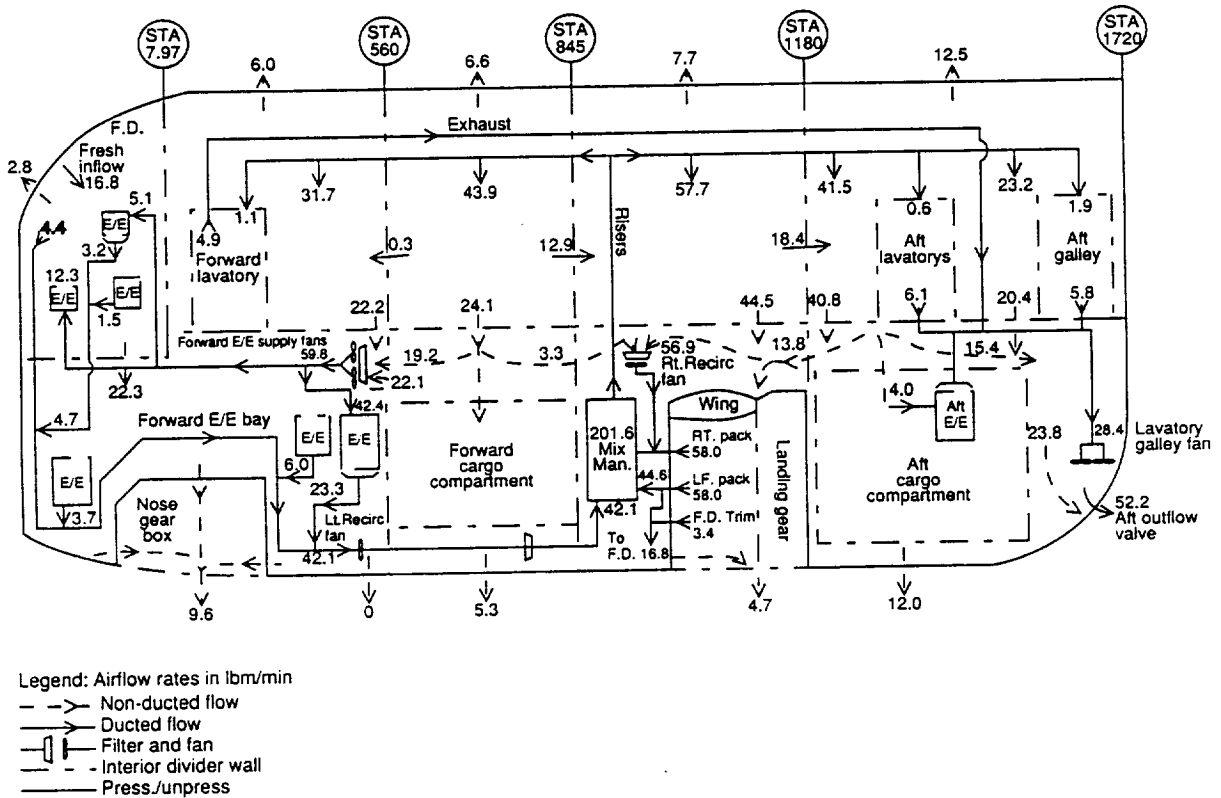

Figure 5.2-5. Aircraft Airflow Distribution.

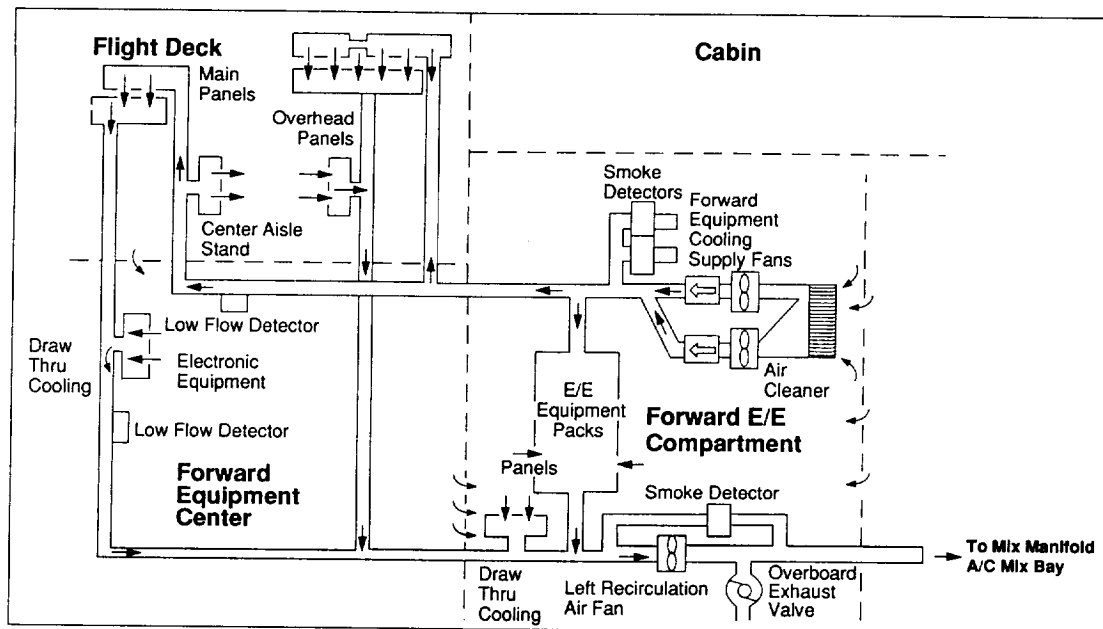

Figure 5.2-6. 757-200 Equipment Cooling Airflow Distribution.

Water mist drawn from the passenger cabin by the forward equipment cooling supply fans will be drawn through a centrifugal particle separator prior to reaching the fan. The purpose of this air cleaner is to remove solid particulates from the airstream to provide clean air for equipment cooling. A swirling motion is induced on the air/particulate mixture as it passes through the cleaner. Solid particulates are thrown radially outward by centrifugal force to the walls of the cleaner and are then removed by the purge system. Thus, clean air is delivered for equipment cooling and solid particulates are continuously removed. Although the cleaner has been tested for solid particulate removal only, the vendor/supplier has determined, but not guaranteed, that water droplets will be removed in the same fashion as solid particulates entering the cleaner. For purposes of this analysis it has been assumed that the cleaner will perform as expected, however, future testing would be required to verify the cleaner's performance. Following vendor/supplier recommendation, droplet size was reduced by 50% for determining cleaner effectiveness at removing mist. Based on a droplet size of 40 microns, it is expected that 96% of the mist entering the cleaner will be removed.

Should the cleaner not perform as expected, there are other filters that are designed for moisture removal and would be adequate for this application. Addition of a mist removal filter may require an upgrade to the current fans in order to overcome the increased pressure losses associated with an additional filter. This type of filter is susceptible to clogging and would require periodic maintenance to clean. Mist that passes through the air cleaner will be evaporated in the air as it passes through the equipment cooling supply fans, where the airstream experiences a 10°F temperature rise. Mist that is captured by the cleaner is expected to puddle in the ducting and would require removal as part of the refurbishment process. Puddled water is not expected to be drawn into any electronics.

Mist drawn from the passenger cabin by the left-hand recirculation fan is expected to pass through some of the draw through cooled electronics prior to reaching the fan.

Table 5.2-1 lists airflow humidity, temperature, and mist rates that are expected to be ingested and/or distributed to 757 electronics. Also listed is the mechanism by which mist is delivered to the electronics.

Table 5.2-1. Mist Distribution Summary for 757 Electronics.

Unit No.	Humidity of Ingested Air (%)	Temperature of Ingested Air (°F)	Mist Ingestion Rate (lbm/min)	Mechanism Causing E/E Mist Ingestion
P33	100	75	0	LH recirc fan
P54	100	75	0.231	LH recirc fan
P51	100	75	0.1155	LH recirc fan
P50	100	75	0.1542	LH recirc fan
P37	100	75	0.2246	LH recirc fan
P32	100	75	0	LH recirc fan
P31	100	75	0	LH recirc fan
P34	100	75	0	LH recirc fan
P70	100	75	0.2738	LH recirc fan
P36	100	75	0	LH recirc fan
E1	100	85	0	E/E supply fan
E2	100	85	0	E/E supply fan
E3	100	85	0	E/E supply fan
E4	100	85	0	E/E supply fan
E5	100	85	0	E/E supply fan
P5	100	85	0	E/E supply fan
P11	100	85	0	E/E supply fan
P8	100	85	0	E/E supply fan
P9	100	85	0	E/E supply fan
P1-1	100	85	0	E/E supply fan
HSI-L	100	85	0	E/E supply fan
ADI-L	100	85	0	E/E supply fan
P1-3	100	85	0	E/E supply fan
P7-L	100	85	0	E/E supply fan
EICAS-T	100	85	0	E/E supply fan
EICAS-B	100	85	0	E/E supply fan
P7-C	100	85	0	E/E supply fan
P7-R	100	85	0	E/E supply fan
P3-1	100	85	0	E/E supply fan
ADI-R	100	85	0	E/E supply fan
HSI-R	100	85	0	E/E supply fan
P3-3	100	85	0	E/E supply fan
LH glare shield	Nom cabin	75	0	LH recirc fan
RH glare shield	Nom cabin	75	0	LH recirc fan
INV	Nom cabin	75	0	LH recirc fan
Battery charger	Nom cabin	75	0	LH recirc fan
Weather radar	Nom cabin	75	0	LH recirc fan
E6	100	75	1.9	Lav/Galley ex fan

Mist drawn from the passenger cabin by the right-hand recirculation fan will reach a filter upstream of the fan. This filter is a paper-type filter and is expected to block all mist and thus eventually clog, and may subsequently stall the right-hand recirculation fan. This type filter is not reusable and will require replacement. The fan is not expected to be damaged as a result of stalling. No impact on electronics cooling is expected, since air drawn by this fan is sent directly to the mix bay for cabin ventilation purposes.

The lavatory/galley fan will draw mist from the passenger cabin through the E6 rack near the aft cargo bay. The expected quantity of mist ingested by electronics on the E6 rack is shown in Figure 5.2-3.

Passenger cabin/flight deck air distribution has been designed such that a positive pressure differential between the crew cabin and the passenger cabin is maintained (i.e., flight crew cabin is at a higher pressure than the passenger cabin) when the flight deck door is kept closed as required by FAR 121.587. This pressure differential will prevent airborne mist in the passenger cabin from migrating to the crew cabin. FAR 121.587 applies to aircraft carrying passengers only, therefore, aircraft in flight for other purposes could be susceptible to mist migration into the crew cabin if the flight deck door is open.

Mist is expected to condense on all exposed surfaces in the pressurized region of the lower lobe (i.e., structure, cabling, insulation blankets, wiring, etc.), except cargo compartment interior surfaces (liners, etc.).

5.2.2 Proposed Design Changes to Minimize Water Ingestion

Main electronic equipment bay ingestion of mist can be eliminated by the following actions at the time of water spray activation:

- Left-hand recirculation fan power is shut off;
- E/E supply fans power is shut off (changes to instrumentation controls may be required);
- Overboard exhaust valve is closed.

It should be noted that this action may conflict with current smoke removal procedures and requirements. A procedure to incorporate the above actions would require analysis to verify that aircraft smoke removal would not be jeopardized, in the unlikely event of accidental inflight activation of water spray with the presence of smoke. Appropriate manual overrides to the valve positions may be necessary.

Aft electronic equipment bay ingestion of mist can be eliminated by the following action at the time of water spray activation:

- Lavatory/galley fan power is shut off.

Damage to the right-hand recirculation filter can be eliminated by the following action at the time of water spray activation:

- Right-hand recirculation fan power is shut off.

In the event that mist is ingested by the electronics, continued air flow through the draw through and blow-through cooling systems would tend to “dry out” any moisture present, since these systems are capable of providing warm air continually. Corrosion potential and reliability concerns would, however, dictate a more “active” approach to drying and refurbishment (Section 5.3 and 5.10).

5.2.3 737 Mist Distribution Analysis

Mist distribution and electronics ingestion of mist within the 737 aircraft is expected to be similar to the 757. Blow-through cooled electronics are expected to ingest negligible amounts of mist since the same type of cleaner exists on the 737 as on the 757. Quantities of mist expected to be ingested by draw through cooling and applied to electronics are shown in Table 5.2-2.

Table 5.2-2. Mist Distribution Summary for 737-300 Electronics.

Component Number	Mist Rate Gallon/Minute*
E1-P	0.19
E1-1	0.05
E1-2	0.1
E2-P	0.19
E2-1	0.13
E2-3	0.09
E3-P	0.18
E3-1	0.04
E3-2	0.04
P6-D**	0
IP-1**	0
IP-2**	0
IP-3**	0
IP-4**	0
IP-5**	0
IP-6**	0
IP-7**	0
IP-8**	0
CDU No. 1**	0
CDU No. 2**	0
IRU No. 1	0.13
IRU No. 2	0.13

* 3-minute duration

** Located on the flight deck

5.2.4 747/767 Mist Distribution Analysis

A mist distribution analysis was performed on the 747-400 and the 767-200 airplanes in addition to the 757 mist distribution analysis. The analysis focused on the inadvertent discharge of the cabin water spray and its effects on the E/E cooling system for these large body aircraft.

The environmental control system was assumed to be in the normal flow mode with three packs operating. The airplane was at a cruise altitude of 35,000 ft. The E/E cooling system was in normal flow mode and the water spray was evenly distributed.

After discharge of the water (2,409 lb/3-min for 747-400), analysis indicated that all but about 430 lbs would either be absorbed by the cabin interior, exit via the outflow valve as saturated vapor, or remain in the cabin air as saturated vapor. After further analysis, it was determined that approximately 36 lbs of free liquid (0.132 lbm free liquid/lbm saturated air) could be ingested by the forward E/E supply fan (assuming no moisture coalesces into bigger droplets and separates out or impinges on the return air exit grills). After filtration of approximately 95% of the free liquid, the quantity of water discharged into the forward E/E bay was estimated to be approximately 1.8 lbm free liquid. The aft E/E bay has no filtration and could expect to see about the same quantity of water as the forward E/E equipment cooling supply fan. Even though similar results were found for the 767 through the same type of analysis, this scenario represents an "artificial worst case", since the 767 E/E bay is cooled in cruise via a skin heat exchanger, and does not receive any mist-laden air. Potential to ingest mist would still exist for the condition where skin temperature rises above 45°F, most likely during ground operations or takeoff, where equipment cooling reverts to forced air.

5.3 ELECTRICAL SYSTEMS

A cabin water spray damage assessment was performed to assess the impact of such a system on airplane operation following inadvertent, inflight operation and commanded operation on the ground. This part of the study was a high level investigation into the performance of 757 airplane electrical systems during and after water spray activation. Of primary concern is the continued safe flight and landing of the airplane, without exceptional pilot skill or strength, following inadvertent, inflight activation. The long term effects of corrosion were also addressed.

The results of the Electrical Systems study are based, in part, on prior in-service incidents involving fluid contamination of electrical systems, vendor qualification data and/or prior testing of specific electrical components, and review of failure modes and effects analysis (FMEA) reports on specific systems.

5.3.1 Ground Rules and Assumptions

Specific assumptions made for Electrical Systems evaluation are as follows:

- Water electrical conductivity is minimized by the use of water with low salinity and mineral content;
- Water that might affect electrical components is relatively free of dry contaminants (dust, minerals, etc.)
- Water is introduced to the E/E bay equipment via mist laden air from the equipment cooling system, as well as drippage from the cabin area through the air vents, carpet and floor panels, onto the E/E racks and panels;
- Equipment cooling system is assumed to remain operative during and after the water spray incident, which raises some concern about fan stalling due to water quantity, and loss of blow-through cooling to specific rack mounted equipment, increasing the potential for malfunction.

5.3.2 Existing Contamination Protection Measures

The current layout of the E/E bay includes protective measures designed to prevent component damage to all E/E equipment. Drip shields in the E/E bay are installed above each of the racks (Figure 5.3-1). Each shield consists of an aluminum pan (or canvas shield in the case of the 737), with a drain to the keel area. The enclosed panels are installed to allow water runoff from the racks to drain down into the fuselage. The racks and equipment enclosures are anodized for corrosion resistance. These protective measures currently allow the racks to tolerate any dripping or condensation that might be encountered in normal service, and assume a maintenance schedule for verifying drain function is followed. It is important to emphasize that these protective measures described refer to the “as-delivered” condition of the airplane. Evidence from inspection of older airplanes suggests that these measures may be compromised during their service life if maintenance procedures are neglected. Increased maintenance might be required to maintain even “as-delivered” levels of protection. Potential consequences of improperly maintained drip shields include water that might normally be collected and directed away from electronics impinging directly on electronics, if the shield is missing or torn, and collected water splashing over rack mounted equipment at aircraft rotation, for cases where the drain might be restricted (Section 5.3.3.5).

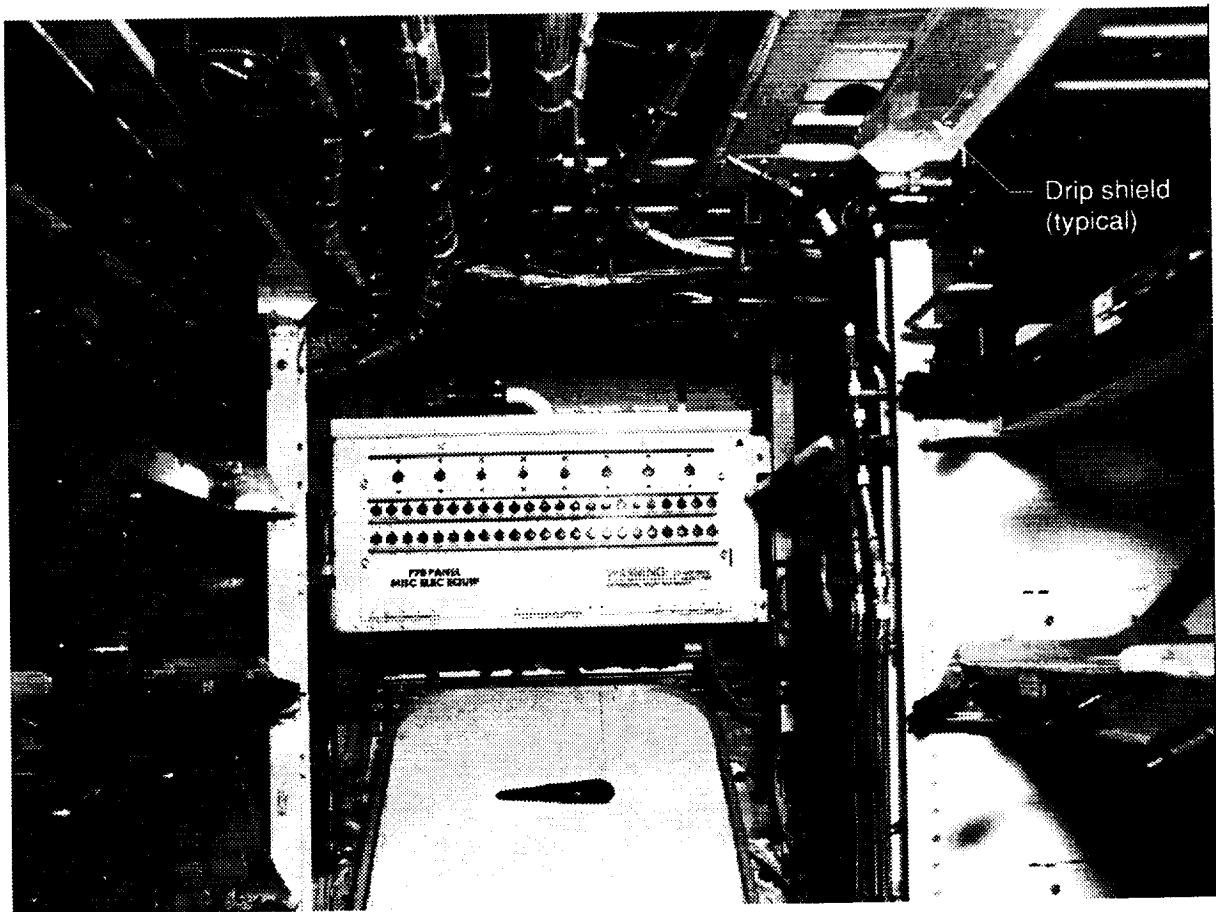

Figure 5.3-1. Forward E/E Bay.

Electrical equipment (relays, switches, connectors, circuit boards, wire, etc.) and their installations were reviewed for water spray susceptibility. Connectors currently in common use include grommet seals designed to prevent water ingress, and should not be affected by the presence of moisture. Relays are hermetically sealed with grommets on the relay sockets, and circuit boards are often fabricated with a conformal coating, both treatments for the specific purpose of preventing contamination by moisture. No deleterious effects are expected from the estimated water quantities applied to these components. Plug-in integrated circuits and board connectors are currently open to moisture. The ingress of water at these points could cause at least temporary system malfunction, component loss, potential system loss, and any subsequent ramifications due to a combination of these failures. Spurious or inconsistent signals to the flight deck may also cause the crew to respond improperly and create a more serious condition.

Currently, electrical circuit separation is required for redundant systems as part of the aircraft's safety philosophy. The airplane wiring design and installation must incorporate appropriate measures to minimize the effect of electrical wiring faults, including those induced by water, and to isolate fault damage and propagation between redundant systems. Wet arc tracking tests have been conducted on general purpose wire insulation used by The Boeing Company. Treated tap water has not caused insulation arc tracking on any of these wires when tested according to Boeing Specification Support Standard BSS 7324. In-service damage to wire insulation has not been considered in the test procedures.

Aircraft maintenance, modifications, and equipment repair could increase the risk of water spray contamination by unintentional compromise of existing protective measures. Design requirements aimed at minimizing contamination susceptibility or exposure are already utilized in aircraft systems, such as wire separation requirements, wire installations incorporating drip loops in water prone areas, and system function redundancy. Further testing of electrical components, such as printed circuit card connectors, is recommended to determine if additional "waterproofing" measures would be needed. It should be noted that these requirements would probably be limited to only those systems deemed necessary for the continued safe flight and landing of the aircraft following an inadvertent discharge of a water spray system.

5.3.3 Electrical Systems Susceptibility to Water Spray

Several 757 electrical systems (power system, high lift control system, proximity switch system) were reviewed for expected system degradation, if any, due to water spray. A general description of each of these systems is given to show that the existing design features are somewhat tolerant of the effects of water spray. These features include system redundancy, physical and functional separation, and system fault protection. Some specific components of these systems were then reviewed and commented on regarding the effects of water spray, if any. The 737 has similarly functioning systems, and any conclusions drawn for the 757 would apply.

5.3.3.1 757 Electrical Power System

5.3.3.1.1 Primary AC System

The primary ac system is a three-phase, four wire, wye-connected system that operates at a nominal voltage of 115/200V and at a nominal frequency of 400-Hz. The generator neutral point is grounded to the airplane structure and the airframe acts as the fourth wire. The system is divided into two main ac channels: the left channel and right channel. Each channel consists of a main ac bus supplied by an associated integrated drive generator (IDG). The two-channel system is designed for isolated operation (Figure 5.3-2).

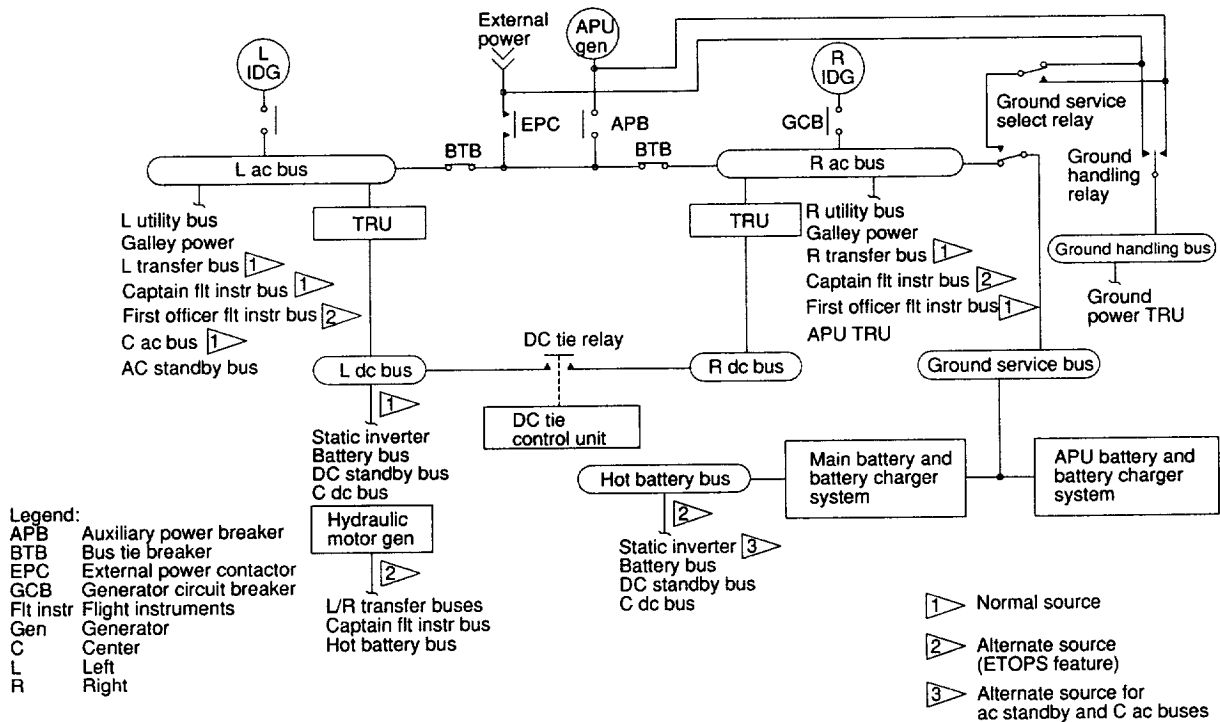

Figure 5.3-2. Electrical Power System.

An auxiliary power unit (APU) driven generator provides dispatch capability if one primary source IDG is inoperative, and, in addition, provides a self-sufficient power source for ground operation. This generator can supply electrical power to all main buses when the auxiliary power breaker (APB) and the bus tie breakers (BTB) are closed.

The system is designed for automatic operation to minimize flight crew workload. Manual override capability is provided for all automatic features except for automatic dc tie control.

Both main ac buses can be supplied concurrently from any one of four isolated power sources (left and right engine generators, auxiliary APU generator and external power source) by means of the interconnecting ac tie bus when the appropriate generator control bus (GCB), APB, BTBs and external power contactors (EPC) are closed. Operation of these contactors is controlled automatically by the three generator control units (GCU), and the bus power control unit (BPCU) to maintain power on the buses from any available source.

Considering water spray through the equipment cooling system, the potential impact to a GCU located on the E5 rack is as follows:

- Based on field experience with GCUs similar in construction to the 757/767 control units, when these units ingest fluids they may fail, resulting in a trip and transfer of the ac bus. In one reported case, the fault continued long enough to experience excessive heat, resulting in a scrapped unit. Because of the extent of the failure, the unit also did not transfer the ac bus, resulting in the loss of that bus.

5.3.3.1.2 Primary DC System

A nominal 28V-dc power system is provided to supply loads requiring dc power (Figure 5.3-2).

The dc main system is a 2-wire system which uses the airframe structure as the ground return circuit. It is divided into the left and right channels. Power is supplied to the dc loads by two 120 amp unregulated transformer rectifier units (TRU), that are energized from the left and right 115V main ac buses, respectively, through thermal circuit breakers. Each TRU powers an associated main 28V-dc load bus. Under normal system operation, the dc battery bus, the dc standby bus and the dc center bus are supplied from the left main dc distribution bus. The TRUs are normally operated isolated to supply their respective load buses.

A dc tie bus and an automatic dc tie control unit and contactor are provided to permit a single TRU to supply all dc buses if required. The dc system is not designed, however, for dispatch with an inoperative TRU. The inherent demonstrated reliability of the TRU makes this requirement unnecessary.

No switching relays or contactors are provided in the ac input or dc output of the main TRUs, and the three-phase input wiring to each TRU is protected by a three-phase thermal circuit breaker. No protection devices are installed on the dc output feeder between the TRU and the dc bus. This feeder is adequately sized to carry dc fault currents up to a level that will cause the three-phase input breakers to trip. Each TRU is designed to deliver a short circuit current to clear the largest size thermal circuit breaker (100 amps) in the dc distribution system without damage to the unit, and without tripping the three-phase input breakers.

Several components, listed in Appendix B as standby powered systems, and defined by Product Safety as required for safe flight and landing, were reviewed for the implications of water ingress based on a worst case scenario of the failure of the centrifugal separator used to eliminate particulates from the E/E cooling air (Section 5.2.1). This failure would result in increased quantities of moisture directed at these key components. This analysis was prepared by the ECS group, and summarized in Table 5.3-1, and results were used in several of the following sections.

Table 5.3-1. Electronics Misting Summary (Assume No Filtration).

Component Name	Mist Ingestion Rate (lbm/min)
Flap/slat electronic unit (FSEU)	0.14
Transformer rectifier unit (TRU)	0.61
Control system electronic unit (CSEU)	
Power supply	0.11
Spoiler	0.02
Yaw damp	0.04
Stabilizer/aileron	0.03
Rudder ratio	0.01
Proximity switch electronics unit (PSEU)	0.123

Considering a water spray that deposits 0.61 lbm per minute for 3-minutes (Table 5.3-1) at the TRU, the potential impact is as follows:

- There are no “bathtub” type water collection features in the design. Therefore, the substantial majority of the water would immediately drain, leaving no collections of water except what surface tension alone would support. While operating, the unit is very warm and it is thought would tend to dry itself out.
- In general, the components contained within the TRU are not moisture failure susceptible. The magnetics are varnish impregnated, the rectifier diodes hermetically sealed and the output capacitors are sealed. There are no circuit boards in this unit.
- The TRU is a low impedance unit. A water bridge across terminals (or other electrical potentials) would create a relatively high impedance parallel path and thus have little performance or damaging affect on the unit.

In summary, the unit would operate without noticeable performance effects. The unit would tend to dry itself out quickly (especially while operating). No permanent damage would likely result. The unit should be thoroughly examined and tested after a system discharge and be repaired or replaced as required.

5.3.3.1.3 Standby Electrical System

A standby power system is provided to supply 28V-dc and single phase 115V-ac power to essential instrument, communication and navigation equipment in the event of complete loss of primary ac power (Appendix B). This system is supplied by a 40 amp-hour nickel-cadmium battery, and consists of the standby battery and battery charger, battery current monitor, a single phase 115V-ac, 400-Hz, 1000 volt-amp static inverter, various control relays, the hot battery bus, battery bus and ac and dc standby buses. A functional diagram of the standby system is shown in Figure 5.3-3. The static inverter functions to convert nominal 28V-dc power from the hot battery bus (or the dc left main bus) to single phase, 115V, 400-Hz ac power.

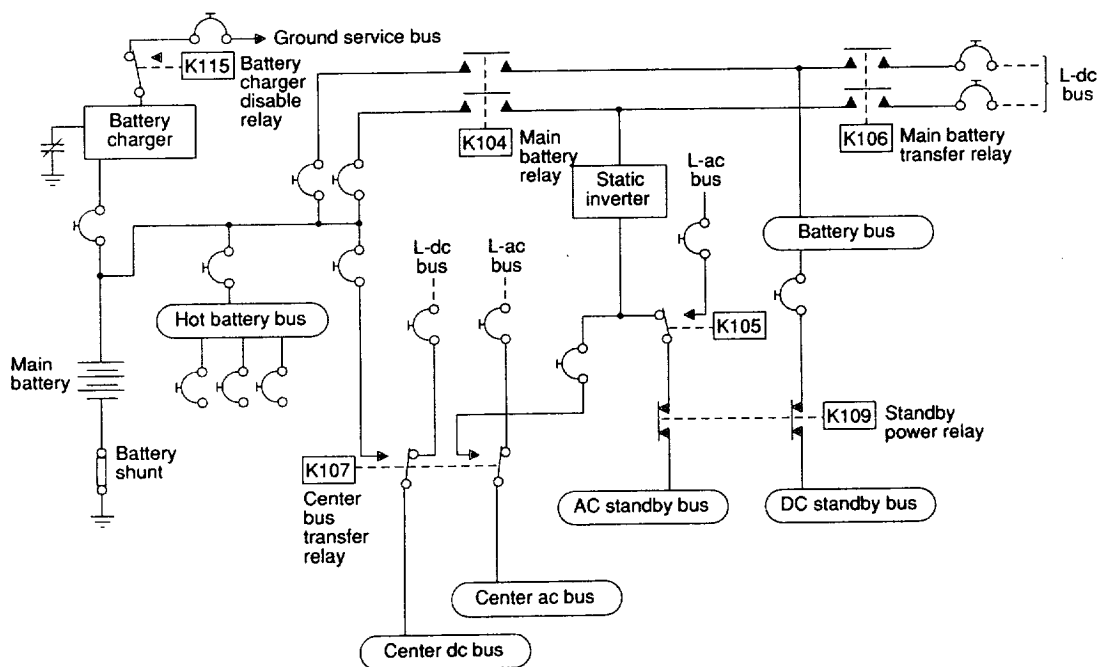

Figure 5.3-3. Electrical Standby Power System.

Considering water mist of 0.1 gallons in the forward E/E bay (Figure 5.2-3), the potential impact on the static inverter located in this area and draw through cooled is as follows:

- Based on rain tests with similar equipment, conformal coating, salt spray and humidity test results, the supplier speculated there would be no effect on the units performance.

5.3.3.1.4 Equipment and Installation for the 757 Electrical Power System

Equipment associated with the electrical power system is installed in the 757 airplane at the various locations shown in Figure 5.3-4. This equipment is connected with different wire and connector types, each suited to the installation location. Wire routing and installation practices follow the wire separation criteria developed for the 757 airplane.

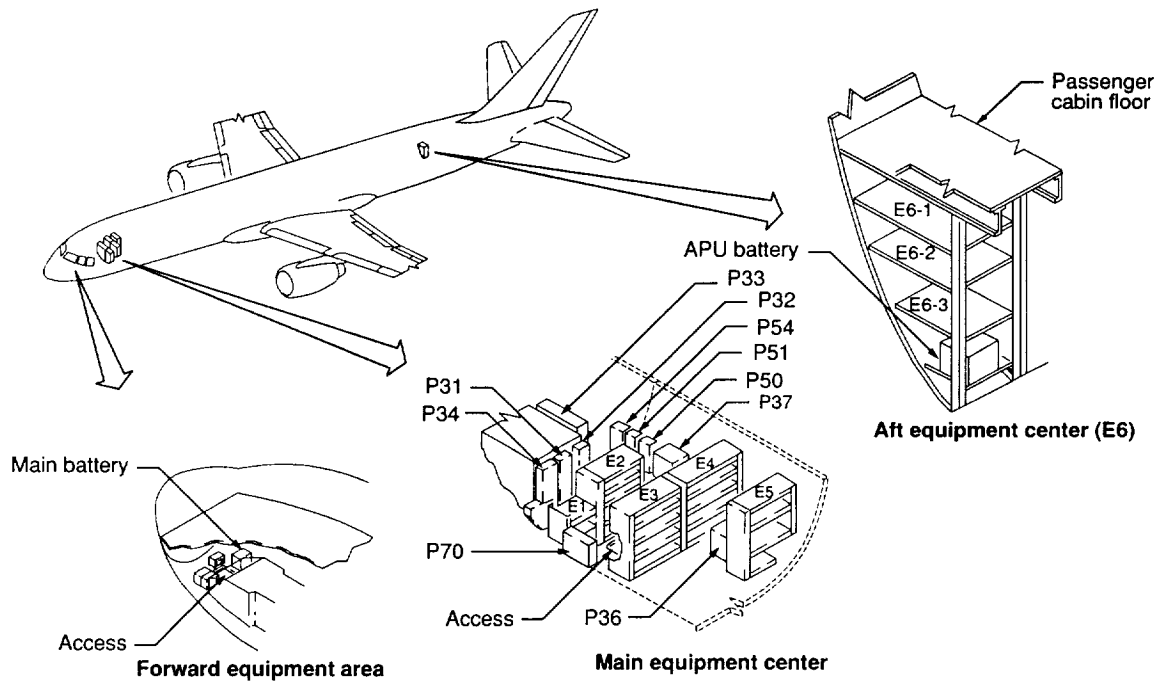

Figure 5.3-4. Equipment Centers.

The wire types used in the 757 airplane comply with the applicable Boeing Material Specifications (BMS). The wire types are compatible with the electrical and environmental requirements of the area in which they are installed.

Wires are grouped into bundles in accordance with the functional separation categories defined in Boeing separation requirements. The major separation categories are left channel, right channel, and standby system channel. Further separation between redundant circuits, and for electromagnetic compatibility reasons is also observed. Separation in consideration of a water threat is not currently considered, except in immediate proximity to current aircraft water systems (potable water and sanitary systems).

Generator feeders are installed such as to provide separation of at least 3-inches from lines carrying fuel, hydraulic fluid or oxygen. To prevent mechanical strain on feeders and their terminations and supports, slack is provided in the cables, and feeder clamps and guides are designed to allow axial movement of the feeders. Major feeders, such as the generator feeder wires and the tie bus, are separated from all other wire bundles.

Power distribution wiring associated with the right, left and standby channels is separated from each other. The power wiring interconnecting the standby battery and inverter, the hot battery, dc standby, ac standby, ac center, and dc center buses is separated from all other power wiring.

5.3.3.1.5 System Fault Protection

The 757 airplane wiring and equipment installation practices incorporate appropriate measures to minimize the effect of electrical faults, and to isolate fault damage and propagation between redundant systems. The main wire bundles in the 757 electrical system are physically isolated so that damage in any single wire bundle will not result in disabling wiring in other wire bundles.

All flight essential electrical equipment on the 757 airplane is provided in dual or triple redundancy, and redundant units are connected to separate power sources (left and right ac and dc buses). Triple redundant systems are connected to left, right, and center isolated buses.

Battery and standby buses are normally powered by the left ac and dc channels, but will transfer automatically to the battery/inverter system in the event of a left channel failure.

Non-essential loads such as galleys, passenger entertainment, etc., are connected to special bus sections which can be de-energized (shed) automatically or manually, thus providing added assurance of adequate power for essential loads during abnormal operating conditions.

5.3.3.2 757 High Lift Control System

The 757 high lift system includes double slotted inboard and outboard trailing edge flaps, and one inboard and four outboard three position leading edge slats on each wing. The hydro-mechanical control/drive system provides normal flap/slat control, with an electrical control/power system providing alternate (back-up) control. Both modes are monitored for proper operation.

Flaps and slats are normally controlled by a single detected flap control lever. Commands are mechanically transmitted to a single trailing edge power drive unit (PDU) that drives a torque tube system. Each flap is driven by two ball-screw actuators from the torque tube. "No-back" devices maintain flap position with loss of power. Slat commands are mechanically transmitted from the trailing edge flap PDU output to a single slat PDU that also drives a torque tube system. "No-back" devices maintain slat position with loss of power. Alternate control is from a rotary selector switch and separate flap/slat arming switches. Alternate control is closed loop. Flaps and slats are powered by electric motors that drive the flap and slat torque tubes. The high lift system is normally depressurized at flaps up conditions. Flap/slat position indication is provided by a single indicator. Electrical control and monitoring functions are implemented in a flap/slat electronics unit (FSEU) using digital technology.

The FSEU (Figure 5.3-5) installed in the E/E bay consists of three physically and functionally isolated, identical channels.

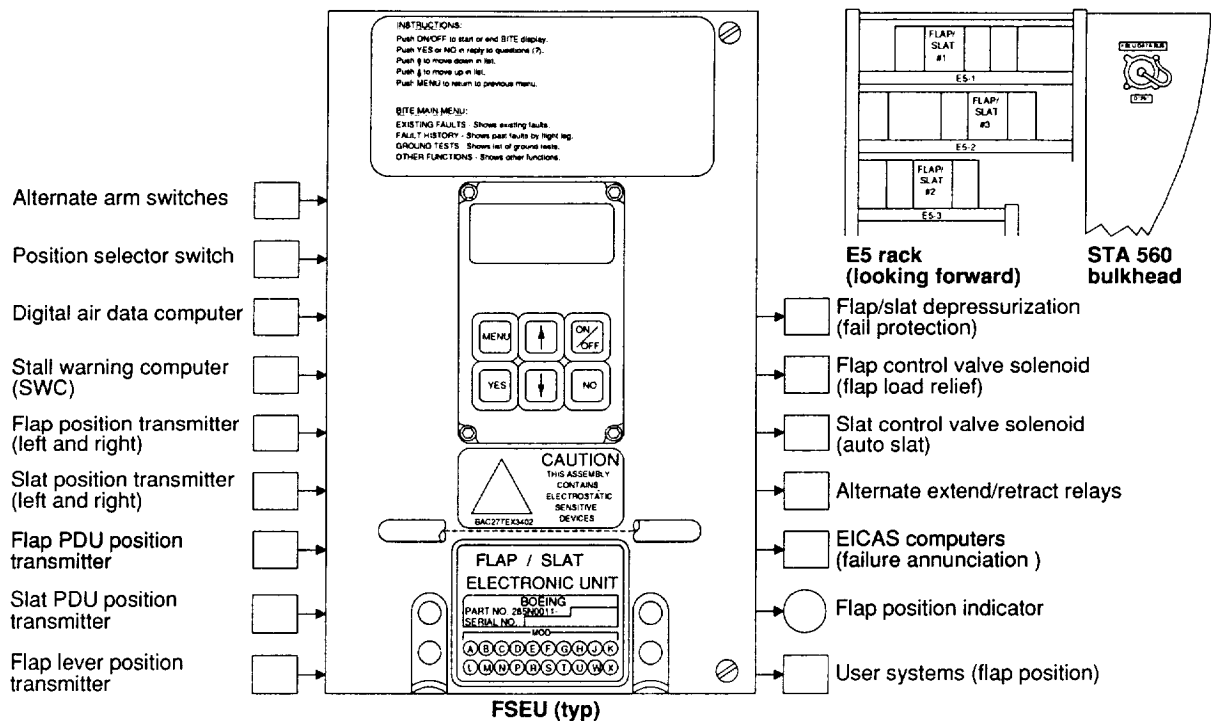

Figure 5.3-5. Flap/Slat Electronic Unit.

Electrical and electronic systems provide alternate drive power, alternate control functions, system position indication, failure detection, failure annunciation, failure protection, autoslat and flap load alleviation control, and high lift system information to other airplane systems. All three electrical power sources (main, APU, standby) are used to power various high lift system components. The power sources are distributed in such a way that no single electrical failure will prevent deployment of the high lift system.

The high lift system failure analysis presents the system hazard assessment of the effects of any single failure, multiple failures, and critical failure combinations with their associated probabilities. Failures of high lift system components are analyzed for their effects on the system and, if necessary, verified on the flight controls test rig and in avionics laboratory testing. Effects on airplane controllability are determined using piloted simulator studies. Significant failure mode effects are verified during flight testing. Individual system component failures are analyzed where possible, on a general failure basis, rather than analyzing each part of each component. Failure mode effects on systems that interface with the high lift system are also considered on a generic level.

The high lift device system is required for dispatch. Loss of this function in flight would require flight envelope restrictions. Certain combinations of failure must be shown to be extremely improbable to ensure continued safe flight and landing without exceptional pilot skill or strength. Loss of normal and alternate high lift control will require flaps up landing. Flap or slat asymmetry will require use of the alternate control system and abnormal operation procedures. The level of criticality of the 757 high lift system is commensurate with FAR 25.1309b (2) since in-flight loss of function will permit continued safe flight and landing.

Considering a water spray that deposits 0.14 lbm per minute for 3-minutes (Table 5.3-1) at the FSEU, the potential impact is as follows: it is assumed that water will spray or drip into all three FSEUs (Section 5.9.2). The effect of water on the FSEUs is unpredictable. Water may cause shorting between pins on the connectors in the FSEU, causing unpredictable circuit function. Erratic outputs to user systems, spurious flight deck indications, shutdown of the leading and trailing edge devices or possibly uncontrolled flap/slat movements are possible effects of this internal shorting. A worst case scenario would be the shutdown of all three units. While it is possible that the flaps and slats would be shutdown in place, due to FSEU command, it is likely that primary control of the flaps/slats would be retained. It is highly improbable that uncommanded flap/slat motion would occur due to FSEU shutdown. As the FSEUs provide primary flap/slat position indication, alternate (electric) flap/slat control and position indication and uncommanded motion (UCM) and asymmetry protection, primary control would likely be retained. Continued safe flight and landing would be possible as primary control of the flaps/slats would likely be intact, albeit without UCM or asymmetry protection. Other systems dependent on FSEU outputs may also be disabled.

In order to return the FSEU to service it should only be necessary to dry the unit and perform a component functional test to verify proper performance. Design changes necessary to preclude FSEU failure due to water spray include environmentally sealed connectors and possibly an environmentally sealed chassis, which would have a significant effect on thermal management.

5.3.3.3 757 Proximity Switch Electronic Unit (PSEU) System

The proximity switch system is primarily used for position sensing of items such as landing gear, thrust reversers and doors. The system consists of position (proximity) sensors installed on the landing gear, thrust reversers and doors and an electronic unit (the PSEU) installed in the E/E bay (Figure 5.3-6). The sensors sense the proximity of targets installed such that switching is accomplished without physical contact between the sensor and target. The PSEU senses target near or target far, and outputs signals that interface with airplane systems. The PSEU has BITE for identifying faulty components.

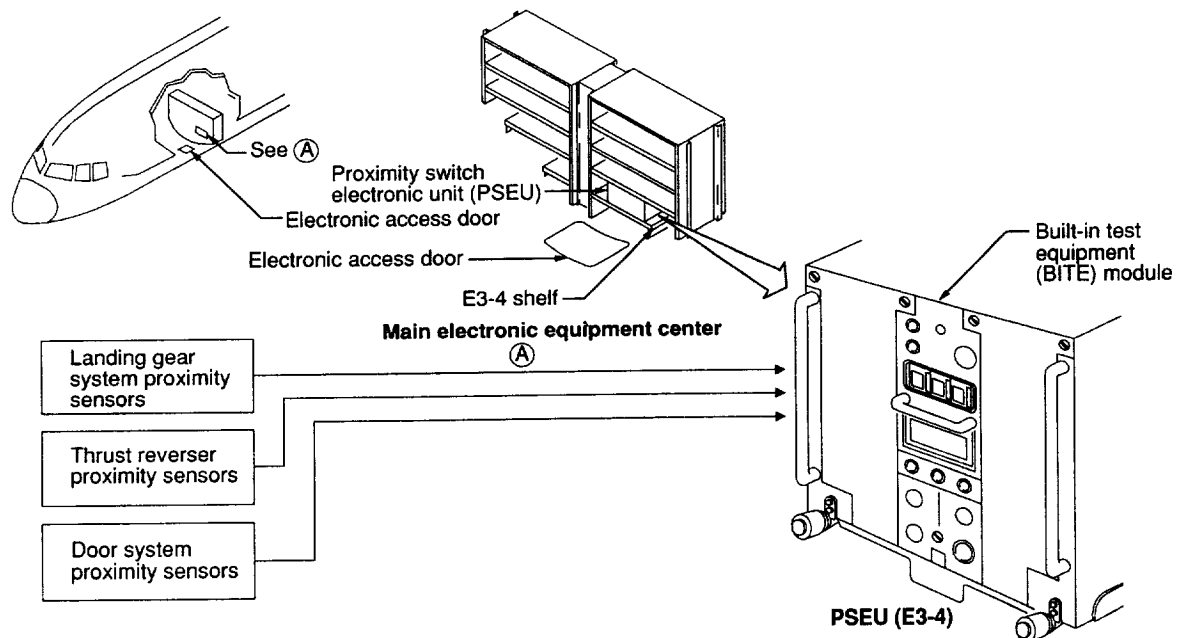

Figure 5.3-6. Proximity Switch System.

Within the PSEU are eight separate subsystems, each having its own power supply. No components in any subsystem are used by any of the other subsystems. The eight subsystems in the PSEU are:

- Cargo door control;
- Door warning indication;
- Thrust reverser indication – left;
- Thrust reverser indication – right;
- Thrust reverser auto restow – left;
- Thrust reverser auto restow – right;
- Landing gear position No. 1;
- Landing gear position No. 2.

Failures in the PSEU may cause either an output to conduct when it shouldn't or not conduct when it should. This is equivalent to short (to ground) or open circuits at the respective output connector pins of the PSEU.

Considering a water spray that deposits 0.123 lbm per minute for 3-minutes (Table 5.3-1) at the PSEU, the potential impact is as follows: circuit boards inside the PSEU are all equipped with a conformal coating and thus are unaffected by moisture. Card edge connectors for these cards are not water tight, and thus may produce sporadic results. A subsequent fire is unlikely, as the circuit breakers will open before this occurs.

Two types of problems may result from water exposure:

- Sporadic/wrong flight deck indications (e.g., landing gear unsafe, doors open, every engine indication and crew alerting system (EICAS) message imaginable).

This first type of problem is somewhat unlikely as the same shorts would have to occur to both System 1 and System 2 (located on different cards), but it is possible. The more likely result will be EICAS messages announcing a difference between the two systems.

- Sporadic/wrong air-ground data: (e.g., it thinks it's in the air when actually on the ground or vice versa). This failure is much less likely as more of the same shorts would have to occur to both systems, thus allowing, but not causing, certain systems to operate when not intended, or preventing certain systems from operating when needed, e.g., preventing the pilot from deploying the thrust reversers on the ground or allowing the pilot to retract the landing gear while on the ground, or inhibiting certain equipment cooling or autobrake operations. It is important to mention that no system connected to the air-ground system is safety-of-flight critical, however, loss of this system will allow, but not cause, activation of systems in situations which could jeopardize safety-of-flight, e.g., flight deck commanded deployment of thrust reversers inflight, and is a significant degradation in aircraft safety.

The longer term effects of water is undetermined, as any liquids would bring impurities into the unit and promote corrosion. It is therefore recommended that the PSEU be cleaned, inspected, serviced and an acceptance test procedure (ATP) performed before readmittance to the airplane.

5.3.3.4 Interior Payloads Systems

The effect on the interior lighting system is difficult to assess. Water from the spray system may be contaminated by dust or other ionic species deposited on the equipment. These contaminants are conductive and capable of sustaining an arc.

If the spray is accidentally activated when the interior lighting is on then:

- Lavatory, galley, ceiling and sidewall fluorescent lights may fail. Contaminated water may form an arc at the lamp holders until they dry out. Whether circuit breakers open or not depends on the duration of arc path. It would be advisable to shed utility bus power upon inadvertent water spray activation, to lessen the possibility of electrical arcing from equipment.
- Reading lights may explode or break depending on the intensity of the thermal shock generated by the difference between water and the bulb temperature when reading lights are on. An arc may occur at the lamp terminal.
- Information signs may short;
- Emergency light battery packs, emergency lights and exit signs may be soaked with water and may become inoperative;
- Emergency lighting systems may be lost, in whole or part, due to electrical shorts, and may result in a slowing down of an evacuation. The emergency lighting system may require recertification and modification as required for use with a cabin water spray system.

5.3.3.5 Avionics

There is an extensive history of fluid contamination in avionics. The most notable was a case where fluid flowed into the digital/analog adapters (DAA) from dripshields on a 737. Both DAAs failed upon takeoff rotation when water flowed onto the motherboard connectors and shorted out the components. All primary attitude indication was lost due to loss of DAA data, a supposedly “extremely improbable” event. This event highlights the potential effects of fluid contamination with avionics.

In this analysis there are two paths of fluid ingress:

- Flowing in by gravity from above shelves, and;
- Blown humidity or mist into actively cooled components.

The primary failure mechanism will most likely be loss of dielectric strength between exposed conductors and printed circuit (PC) traces and loss of dielectric strength in ambient air.

The loss of air dielectric strength is probably not likely unless there is a high voltage power supply (HVPS) present in the line-replaceable units (LRU). Arc over may occur in these LRUs with HVPS during high concentrations of moisture contamination. These LRUs are the electronic flight instrument system (EFIS), weather radar (WXR), and control display unit (CDU) displays and inertial reference unit (IRU). All of these are actively cooled. If arc over does occur, the unit will most likely fail completely causing master warnings to the pilot.

The majority of avionics may experience some degree of condensation or accumulation of droplets on the PC cards. Since the cards are provided with a conformal coating, this condensation probably will not cause erratic behavior or failure. Condensation occurs naturally and frequently due to the thermal cycling of units in and out of humid conditions.

A concern would arise if the droplets conglomerate and drip into board connectors. This would cause shorting like the DAA failures. LRUs with connectors perpendicular to the LRU bottom (vertical) would be less susceptible to this failure mode.

In newly delivered aircraft, the avionics are protected from overhead dripping by shields placed above the electronic racks. However, if these shields are not maintained properly water may drip into the equipment. Numerous instances of LRU corrosion and fluid ingress have been reported by airlines from this cause.

If the units continue to operate even if contaminated, a secondary failure mode may become predominant. This failure mode typically manifests itself as corrosion within the LRU. The corrosion would be compounded by any existing dry contamination within avionics.

The following are recommendations if CWS is to be implemented:

- Either the cooling system or the avionics design of critical systems and their power sources must be changed to preclude avionics failure during flight given an accidental deployment of the system;
- Qualification tests must be designed and conducted to prove avionics immunity to moisture contamination;
- It is recommended that LRUs are cleaned and dried thoroughly after a discharge of the CWS system;
- Proper maintenance of the dripshields must be emphasized.

5.3.4 Return to Service Issues

Following an inadvertent discharge of a cabin water spray system, certain steps would be necessary in a return to service program. Since the long term enemy of equipment from water impurities is corrosion, the electrical equipment determined to have been sprayed or affected by water must be thoroughly examined. Equipment must be inspected, cleaned, serviced, and repaired or replaced as required. A thorough component and system functional test must be performed. Wire bundles must be inspected for water contamination, evidence of wire overheating, or arc tracking, and repaired or replaced as required. Modification of the affected installation as required, such as re-orienting disconnects, adding drip loops, etc., will help preclude occurrence of water spray contamination.

5.3.5 747/767 Airplanes

An assessment of the other airplanes in the Boeing family was made to establish specific differences from the study baseline 757. Since the direction of the study became relatively generic, the conclusions drawn regarding electrical equipment and systems in the 757 can be applied to the other airplanes as well. However, two items which are unique to the 747/767 airplanes were specifically evaluated, and scenarios considering their damage or failure are presented here.

The flight management computer (FMC) is a navigation and guidance system designed to allow the pilots to pre-program the desired flight plan, including routes, waypoints, and optimum efficiency flight profiles into a central data base which provides direction to the autopilot flight director system (AFDS). These systems are similar on 747 and 767 airplanes. Intent of these systems is to reduce pilot workload, and provide maximum fuel economy for a given flight. Design and construction of these system components is consistent with other electrical components previously described. Failure of the FMC or AFDS due to water ingress would require the flight crew to take manual control of the airplane, including all navigation and position calculations, throttle functions, etc. In short, the airplane would need to be flown by the flight crew, who would lose the convenience of automated flight guidance. This is not a "continued safety-of-flight" issue, but would most certainly require thorough checkout after a water spray discharge to prevent future anomalies.

The flight control electronic system (FCES), which is found on the 747 only, provides control indication and fault reporting for the airplane's control surfaces, as well as signals for flight control surface movement during autopilot flight regimes. In addition, control surface trim functions and flap positioning (leading and trailing edge) is controlled through the flap control unit (FCU) modules within the FCES. Once again, these module's construction is consistent with other electrical components, and are relatively moisture resistant due to design requirements imposed by standard 100% humidity test requirements. However, extreme moisture conditions could damage the electronic cards by shorting connector pins. Since primary flight control is by mechanical means, loss of the FCES would not compromise major flight controls. As a worst possible case example, loss of all three FCUs due to shorting from water damage would require use of the alternate electric mode, with the flight crew operating flaps by bypassing the FCUs. Loss of the FCES would not compromise the "continued safe flight" of the airplane.

5.3.6 Summary

Study results conclude that the electrical equipment as presently manufactured and installed is somewhat resistant to a water spray system. The components are currently designed and qualified to meet similar specific requirements (e.g., humidity, salt water spray). One of the identified concerns from a system performance standpoint are the printed circuit card connectors within the equipment boxes (LRUs) and card files. These exposed contacts are vulnerable to shorting/arcing depending upon, but not limited to, such factors as the voltage levels present, the electrical conductivity of the water, and the installation/orientation of the part. Boeing manufacturing processes are designed and implemented with an objective of minimizing the susceptibility of fluid contamination to the aircraft systems. The possibility exists, however, that a system electrical malfunction could occur if contaminated by water spray, resulting in erratic system behavior. The extent of the malfunction would need to be determined by testing (both laboratory and flight), and failure analysis. The electrical conductivity of the water spray is a factor of concern and should be minimized (e.g., use distilled water or chemical additives). The specific electrical systems discussed in this study were chosen because of their affect or inter-relationship on other aircraft systems. The efforts of this study resulted in the conclusion that some electrical system degradation or failures from water spray is likely, even with current or proposed protective measures, and do not necessarily preclude the continued safe flight and landing of the airplane, however, these failures can adversely affect current levels of safety. Rigorous testing is warranted to determine the modes and degrees of failure which might be expected following a water spray discharge, and to identify protective measures which will make this type of degradation "highly improbable".

5.4 PROPULSION SYSTEMS

This section presents a study of the effects of cabin water spray discharge on 757 propulsion system components. The purpose of this study is to determine the potential failures in the propulsion system that would affect safety-of-flight. The potential failures that are common to other current production airplanes are also briefly discussed.

5.4.1 Introduction

No component of the propulsion system is located in the defined spray area, however, certain propulsion system controls and indicators could be subjected to mist absorbed by the ECS and/or to water spills or dripping of water through the floor panels. These components are located in the forward and aft E/E bays and the cockpit.

Based on the Electrical Systems group's findings (Section 5.3), only the plug-in integrated circuits and board connectors in the E/E bays are particularly susceptible to moisture. Connectors and relays are protected by grommet sealing and circuit boards are provided with a conformal coating. E/E racks are equipped with drip shields and drains installed above each rack, and the E/E panels are fully enclosed and installed to channel water runoff down the back of the panel. It must be emphasized these findings are based on the delivered configuration only and they may not hold true throughout the life of the airplane, e.g., the drip pans may be removed and not replaced, become torn or clogged, or seals broken as a result of maintenance actions.

During these evaluations, it became clear that prediction of modes and degrees of failure is difficult without actual testing of specific cases. This section of the report contains speculations of worst case failures. Section 5.4.2 contains a brief overview of each of the identified components' functions, and modes and effects of the worst case failure.

5.4.2 Discussion

5.4.2.1 E/E Forward Bay Equipment

The Propulsion System items in the electronic equipment forward bay include:

5.4.2.1.1 Propulsion Discrete Interface Unit (PDIU) For 757 Pratt & Whitney (PW2000) Installation Only

The PDIU, located in the E/E bay, is a digital processor that collects, processes and converts airframe analog discrete data signals to an ARINC 429 digital bus data format for use by electronic engine control (EEC), and provides data from one engine for the other engines starting. In the event that the unit fails, the EEC replaces the inputs with default values, and the starters have to be operated manually. In the event of erroneous outputs from the PDIU, the EEC is unable to detect errors, thus the EEC may reduce engine thrust slightly. None of these errors would result in an engine shutdown.

5.4.2.1.2 EEC For 757 Rolls-Royce Installation Only

The EEC for the Rolls-Royce, RB211-535 main engine provides limiter and supervisory control. The supervisory control provides automatic rating protection and controls the fuel flow torque motor to match the engine pressure ratio (EPR) set by EEC. The limiter control drives the torque motor to maintain the engine N_1 (low rotor speed).

If the supervisory control detects a failure, the limiter freezes current to the torque motor and the pilot is warned by a lamp. There is no need for immediate action from the pilot, but he must eventually revert to limiter control. To do this, the pilot must first back off the throttle and then press the supervisory control INOP reversion switch located on the overhead panel.

In the event that the limiter should fail, the fail-fix solenoid hydraulically freezes the trim existing prior to the failure. Again, there is no need for immediate action from the pilot, but he must eventually revert to hydromechanical control. To do this, the pilot must first back off the throttle and then press the limiter control INOP reversion switch located on the overhead panel.

The two EEC units are located in the E/E bay. Present operating policies allow the airplane to be dispatched with one inoperative EEC, per minimum equipment list (MEL).

5.4.2.1.3 Engine Indication and Crew Alerting System

The EICAS system includes two CRT display units located on the flight deck, and two independent computers. The purpose of this system is to provide the flight crew with primary engine parameters (full time) and with secondary engine parameters and warning/caution/advisory messages (as required).

The two EICAS computers are co-located in the same rack. Therefore, in the event of water spray activation, the potential for common cause failure from spray contamination (Section 5.9) exists with the current configuration. Section 5.3 outlines likely effects from water ingress into sophisticated electronic components, such as the EICAS computers.

The EICAS computers are considered essential safety-of-flight systems. Present operating policies allow the airplane to be dispatched with one of the display units, or one of the computers inoperative (i.e., one of four components inoperative). A standby engine indicator is a third back-up system that displays the primary engine parameters necessary for continued safe flight.

5.4.2.1.4 Electrical Relays, Connectors and Wiring For EEC Channel Select and Fuel Shutoff

The fuel shutoff circuitry controls the fuel flow to the engines. Circuitry malfunctions could, in a worst case scenario, cause a fuel shutoff and eventually de-power an engine, resulting in uncommanded loss of power.

The EEC channel select circuitry (for PW installations only) allows the pilot to switch the PW EEC to the secondary channel. The secondary channel, however, may not be operational at all times, specifically because it is acceptable under present policy to dispatch an airplane with one channel inoperative. Therefore, in its current configuration, it is possible to have an engine shutdown if the EEC fails into the secondary channel mode, and the secondary channel is inoperative.

5.4.2.1.5 Fuel Quantity Indicating System (FQIS)

The FQIS displays the fuel quantity, and alerts the flight crew to low fuel quantity, fuel imbalance, and fuel system component failures. In the event of a FQIS unit failure, as might be expected with water damage, it is possible for EICAS to display an erroneous LOW FUEL caution alert and/or for the FUEL CONFIG light to fail to illuminate. A LOW FUEL caution indication is taken very seriously, with the airplane diverted to the nearest airport.

5.4.2.2 E/E Aft Bay Equipment

The propulsion system item of concern in the E/E aft bay is:

5.4.2.2.1 Auxiliary Power Unit Full Authority Digital Electronic Control (APU FADEC)

The APU FADEC is an integral component of the APU control system, providing speed control, surge and inlet guide vane (IGV) control, and shutdown protection. A malfunction in the unit, such as have been described in Section 5.3, could result in an uncommanded shutdown of the APU, if running when required by ETOPS procedures.

The APU is a small auxiliary engine that provides pneumatic flow for main engine starts, environmental conditioning, and shaft power to drive an electrical generator. It is generally used on ground prior to main engine start. Inflight, it is used as a backup system only, and an aircraft may be dispatched without an operational APU, unless that airplane is flying on extended-range twin operation (ETOPS). For ETOPS airplanes, the APU is considered a necessary backup system, should there be a main engine failure. The APU for 737 and 757 (as required) ETOPS airplanes must be running at altitudes greater than or equal to 25,000 ft, when the airplane is flying in extended range operation.

5.4.2.3 Flight Deck Equipment

The flight deck area is not in the defined spray area, and the presence of water there is unlikely. However, the propulsion system components on the flight deck include:

5.4.2.3.1 Resolvers For Thrust Controls For Pratt & Whitney Installation

Resolvers supply electrically isolated thrust command signals (thrust lever resolver angle) to the engine fan case mounted EEC. These angles are provided by the thrust levers. Each resolver has two inputs, one per each channel of the EEC. The resolvers are hermetically sealed and rubber inserts in their connectors prevent moisture penetration.

The system is vulnerable to failures resulting from water damage, however, at wiring and connectors that connect the resolvers with the EEC. This wiring runs through the pressure hull, and is subject to many of the spray concerns addressed in Section 5.3. Additional concern, as stated in Section 5.2.1, is that measures designed to isolate the flight deck from threats such as this are compromised in-service, thus increasing the potential for water ingress on the flight deck and the failure of critical systems then being very high. While it is unlikely that a trace of moisture would have any negative effects with currently in-place protective measures, in a worst case scenario, the engine could revert to idle thrust.

5.4.2.3.2 Fuel Control Switch

This switch controls the fuel flow to the main engines, and a malfunction such as an electrical short could lead to a main engine shutdown. As stated previously, the definition of the spray area should preclude any such event as long as the proper flight deck isolation measures are not compromised.

5.4.3 747/767 Airplanes

The previous discussions regarding the fuel shutoff circuitry in the E/E bay, the resolver signals, and the fuel control switch in the flight deck are applicable to all 747/767 models. Therefore, a re-evaluation of the current protective measures for all of these airplanes is required to assure safety.

5.4.4 Summary

Additional moisture-proofing protective measures may be required for the components in the EEC channel select, fuel shutoff and resolver circuit, and fuel control switches because a failure in one or more of these components could possibly result in a loss of main engine power. Considering the possibility of common cause failure (Section 5.9.2), it is not unreasonable to project to the potential for loss of all engines, and the possibility for an un-powered, off-airport landing. Past incidents of this nature have resulted in fatal accidents. In the aircraft's delivered configuration, these components are protected from moisture in various ways (Section 5.3.2), but it is possible for these protective measures to be unintentionally compromised as a result of aircraft maintenance and repair. The belief, based on available data, is that any malfunction in the remainder of the identified propulsion components that would affect the continued safe operation of the engines is highly improbable. Some of these malfunctions could slightly degrade engine performance, while other malfunctions might be considered tolerable because of existing system redundancies. Propulsion recommends extensive testing to verify the adequacy of all current protective and backup measures. Furthermore, all the recommendations for minimizing water ingress made in the electrical section are endorsed here.

5.5 FLIGHT CONTROL SYSTEMS

5.5.1 Introduction

This portion of the study was conducted to determine the potentially negative effects that an activation of a cabin water spray could have on flight controls of the 757. Inadvertent activation was studied for its effect on continued control of the airplane; for taxi back to the ramp in the on-ground case, or the continued safe flight and landing for the inflight case. Suggested methods by which the negative effects could be reduced are included herein. Because of system design similarity, disbenefits described for the 757 will also apply to 737, 747, and 767, in the broad sense. The fly-by-wire architecture for the 777, however, will be addressed separately.

5.5.2 Assumptions

Water from the cabin water spray system was considered to be confined to the pressurized fuselage of the airplane, excluding the flight deck (Section 5.2.1). Therefore, equipment located in the wings, fin, or stabilizer, is not expected to be affected. Since it is impossible to predict precise water paths following discharge, the assumption was made that if a component could be effected by water, it would. Cabin water spray is assumed to be a one-time event only, and, repeated sprays leading to part corrosion are not considered. Inadvertent inflight water spray in conjunction with other system failures was not considered in this analysis, but multiple failures have, in past incidents, been the cause of numerous fatal accidents, and should not be trivialized.

5.5.3 Background

The flight controls systems on the 757 consist of the following: ailerons, configuration warning, elevator, hydraulics, leading-edge devices, rudder, spoilers, stabilizer, and trailing-edge devices. Primary control surfaces are hydraulically powered, and controlled by cables for airplanes other than the 777.

The flight controls system is made up of a complex interaction between electronic, hydraulic, mechanical and avionics equipment. Switches and mechanical levers on the flight deck communicate to pulley cables and avionics components such as the flight control computers. These, in turn, communicate electrically or mechanically with hydraulic actuators, valves, reservoirs, pumps and other equipment. Electronics also perform system monitoring and fault analysis, monitor inputs for air speed and control surface position, and provide flight deck warnings.

A failure in one piece of equipment, due to cabin water spray, may affect not only the operation of that part, but can also impact other equipment. This is especially true in the case of electronic equipment. Prediction of all possible effects of water spray on equipment is not possible when the configuration of the cabin water spray system is not known. However, some generalizations and predictions of failure are possible, and their implications can be assessed.

5.5.4 Failure Prediction

All flight control equipment in the pressurized area was reviewed to assess the possibility of malfunction when exposed to water. Most mechanical and hydraulic equipment, such as the ram air turbine or hydraulic reservoirs, are water-resistant by design. However, there are two types of failures which potentially could occur if the flight controls equipment is exposed to water. These are:

- Water freezing on cables preventing movement of the control surface hydraulic actuator;
- Electronic part failure or malfunction.

Freezing water would most probably be found only on the pulley cables at the points where the cables travel from the pressurized area to the unpressurized area. In these areas, small amounts of moisture could freeze. This should not restrict the use of the cables for two reasons: 1) it is unlikely that the ice will be in such a quantity as to inhibit primary cable movement; 2) if primary cable movement is inhibited by ice, then backup cables, breakouts, etc. will protect against cable jams.

Ice formation is not expected to occur in other sections of the pressurized area. Outside the pressurized area, parts are designed to withstand ice formation.

The second type of failure which could occur is failure of electronic parts when exposed to water. Some electronic equipment is moisture tolerant and would most likely not be affected. Other equipment may be affected, but is not considered to be critical to the system. However, several parts could possibly malfunction if exposed to water. Most of the electronic equipment which might be expected to fail is located in either the electronics bay, or the flight deck, which is out of the defined spray area. Failure of equipment in the electronics bay, due to an inflight cabin water spray, could cause situations that are difficult to control or are confusing to the flight crew. Several modules may be sensitive to a cabin water spray during flight. A brief discussion of these modules, and the implications of malfunction, are discussed here:

- Flap/slat electronics unit – in the worst case (all three units fail) unpredictable circuit function could occur, possibly resulting in erratic flight deck indication (Section 5.3.3.2).
- Proximity switch electronics unit – failure could cause sporadic/wrong flight deck indications or sporadic/wrong air-ground data (Section 5.3.3.3).
- Stall warning module – failure of both modules could result in a failure of the control column to warn the pilot by vibrating when a stall condition is being approached. Other flight deck indicators, however, also warn of a stall condition and failure of this module will not affect continued safe flight of the aircraft, however, overall levels of safety will be reduced.
- Control systems electronics unit – these two units contain modules such as the yaw damper, rudder ratio changer and the spoiler control. The airplane can be controlled safely without the use of these modules. Failure of the spoiler control module results in spoiler shutdown, thus preventing uncontrolled spoiler movement. Failure of these modules could result in sporadic flight deck messages and could result in a higher workload for the pilot.
- Stabilizer trim/elevator asymmetry module (SAM) – failure of SAM would result in the pilot having to control the stabilizer manually, through back-up cables. SAM also provides airspeed inputs to the rudder ratio changer modules and elevator asymmetry modules. It is highly unlikely that SAM would provide incorrect data to these modules, but this possibility must be considered.
- Flight control computers – failure of the flight control computers would prevent auto-pilot control of the stabilizer and elevator. However, manual operation would not be hampered.
- Engine indication and crew alerting system (EICAS) – EICAS is a system which alerts the crew to faults and failures in the aircraft systems, including flight controls systems. Failure of EICAS could result in erroneous signals of the flight deck EICAS display.
- Configuration warning modules – These two modules process input signals from airplane sensors, avionics systems, and pilots to determine if the airplane is in the correct configuration for takeoff and landing. Aural and visual warnings appear on the flight deck if the airplane is incorrectly configured. It is unlikely that these modules would give a false warning of a configuration error. Failure of these modules will not prevent the pilot from safely flying the aircraft, but could cause confusion, or may not warn the pilot of a configuration error. Other indicators on the flight deck, however, would also warn the pilot that the airplane was not configured correctly.

A failure in any one of these modules is not expected to create a situation which the pilot cannot control. However, the workload of the pilot would almost certainly be increased, and levels of safety reduced. Failure of more than one unit could have greater effects than are predicted here, and could, in a worst case scenario, cause uncontrolled movement of some surfaces.

5.5.5 Mitigation of Disbenefits

The electronic components in the flight controls systems that are at risk from a water spray system can be protected from part failure by sealing the electronic parts against water, ensuring that electronics bay units cannot be damaged by water sprays. These steps are discussed in Section 5.3, however, as outlined there, absolute water proofing measures could affect overall thermal management within the bay. To offset this problem requires knowledge of the installation of the cabin water spray system. Once the system configuration is known, testing must be performed to determine where the water is likely to collect and the total amounts of water involved. This will allow for a more detailed look at how parts could fail, and those that are more likely to fail. From these tests, design practices can be modified to prevent ice build up or water collecting near sensitive equipment in such a way as to avoid negative effects on other aspects of systems design.

5.5.6 777 Fly-by-Wire System

Unlike the other Boeing aircraft covered in this study, the 777 uses a fly-by-wire system to command the primary control surfaces, and includes minimal mechanical back-up. One pair of spoilers and the horizontal stabilizer do have pulley cable back-ups. However, in calculating probability of system failure, no credit has been taken for these mechanical back-ups.

Operation of primary flight controls is accomplished through the actuator control electronics (ACE) equipment. This equipment consists of LRUs, mounted on racks in the aircraft's E/E bay. Construction is similar to other electronic components described in Section 5.3, and is subject to many of the same concerns. Connectors have been identified as the vulnerable element in any electronic component, and remain so here. Clean, contaminant free water, as might be experienced in component testing programs, carries a relatively minor threat potential. For an in-service aircraft, the threat from contaminant laden water is significant. Contamination of contacts by debris transported in water deposited on these metal contacts can result in undesired bridging across pins, with degraded signals and cross-talk the likely results. Also, as described in Section 5.9, the potential for common cause failure is introduced, and the layout of the E/E bay equipment must take this threat into consideration, to assure the proper levels of redundancy among the system's components, and to assure functionality for continued safe flight.

In summary, it is inappropriate to discuss the susceptibility of the fly-by-wire electronics to damage from water spray, since incorporation of this system will require substantial design effort to incorporate the appropriate protective measures already discussed in Section 5.3 into vulnerable components to avoid a loss-of-control accident.

5.5.7 Summary

Inadvertent inflight activation of a water spray system can cause malfunctions to the airplane's flight control systems. A further system review will be required if a detailed water spray system is to be configured. As with any new system added to an already complicated aircraft, each change and its effects will have to be analyzed on an individual component basis, and for the effects that any one failure might have on other systems and their impact on continued safe flight.

5.6 STRUCTURES

This section of the report presents the disbenefits to the airplane from a structures perspective, and covers 737, 747, 757, 767, and 777 models. All items discussed are irrespective of the water spray activation scenario, since, from a purely structures point of view, the only real point of concern is the time allowed to pass before a complete teardown for drying, elimination of the potential for corrosion as quickly as possible being the goal.

5.6.1 Assumptions

Water used in the spraying process is considered to be of low salinity and acidity and free of compounds that would have a significant impact on the speed of any corrosive process. Second, the reconditioning process following a water spray event would begin immediately, and not be delayed for attention during subsequent periodic structural examinations. Finally, an unwarranted water spray activation would be treated as a serious event, and not a minor inconvenience. Corrosion damage caused by "minor" liquid spills and lavatory overflows has been shown to be a significant problem for airline maintenance programs, and the subject of numerous "fixes" by airframe manufacturers. It is therefore assumed that the reconditioning following a water spray discharge would be an aggressive program aimed at eliminating any long term effects.

5.6.2 Structural Considerations

5.6.2.1 Fuselage Structures

There are no significant, near term structural problems which might occur due to a water spray deployment, inadvertent or otherwise. The long term concern is water trapped in the structure that could result in increased corrosion potential. Elaborate protective measures have been developed and implemented over the years to protect areas below doors, galleys, and lavatories from the effects of seemingly "minor" liquid spills. On later model 737s and 747s, all 757s, 767s and future 777s the majority of the upper and lower lobe structure is protected by corrosion inhibiting compound (CIC) such as LPS3, that is applied during construction and needs to be re-applied every 2 to 5 years, depending on location. Re-application of this CIC is usually done with normal preventative maintenance and overhauls.

As described in Section 5.1, an unknown quantity of water is expected to leak through floor panels, after saturation of the passenger cabin carpeting. Although the main deck floor panels are sealed (with RTV compounds) for approximately one-third of the aircraft (around doors, galleys and lavatories), water will eventually seep through the joints, especially where panels are not properly re-sealed after periodic inspections. All unsealed sections over the remaining two-thirds of the aircraft are assumed to leak immediately. Water would then run down into the lower lobe, but would leave some trapped between panels on top of the floor beams. This trapped moisture would become a significant corrosion concern if no cleanup or drying were effected.

In addition to the water leaking through the floor, the proposed spraying of water directly into the overhead would result in runoff past and over the sidewall panels and into the insulation blankets, and stringers. Existing drain paths in the fuselage consist of 3/8-inch dia drain holes spaced at regular intervals along the stringers, eventually zigzagging down to 3/8-inch dia pressurized drain valves in the belly of the aircraft. These drain holes and valves are designed to remove condensation accumulations from the airplane. The valves are open on the ground when the airplane is depressurized. Following a water spray event, these drain paths could become clogged from dust and debris washed through with collected water spray, causing trapped water and a potential corrosion problem. This situation is certainly realistic from an operational point of view. Figures 5.6-1 and 5.6-2 show dust and debris accumulations in the lower areas of a recent vintage 757. The "washing" effect that significant quantities of water would have on this type of accumulation would almost certainly result in trapped moisture, and clogged drain paths. Increased maintenance to eliminate this type of build-up might be necessary.

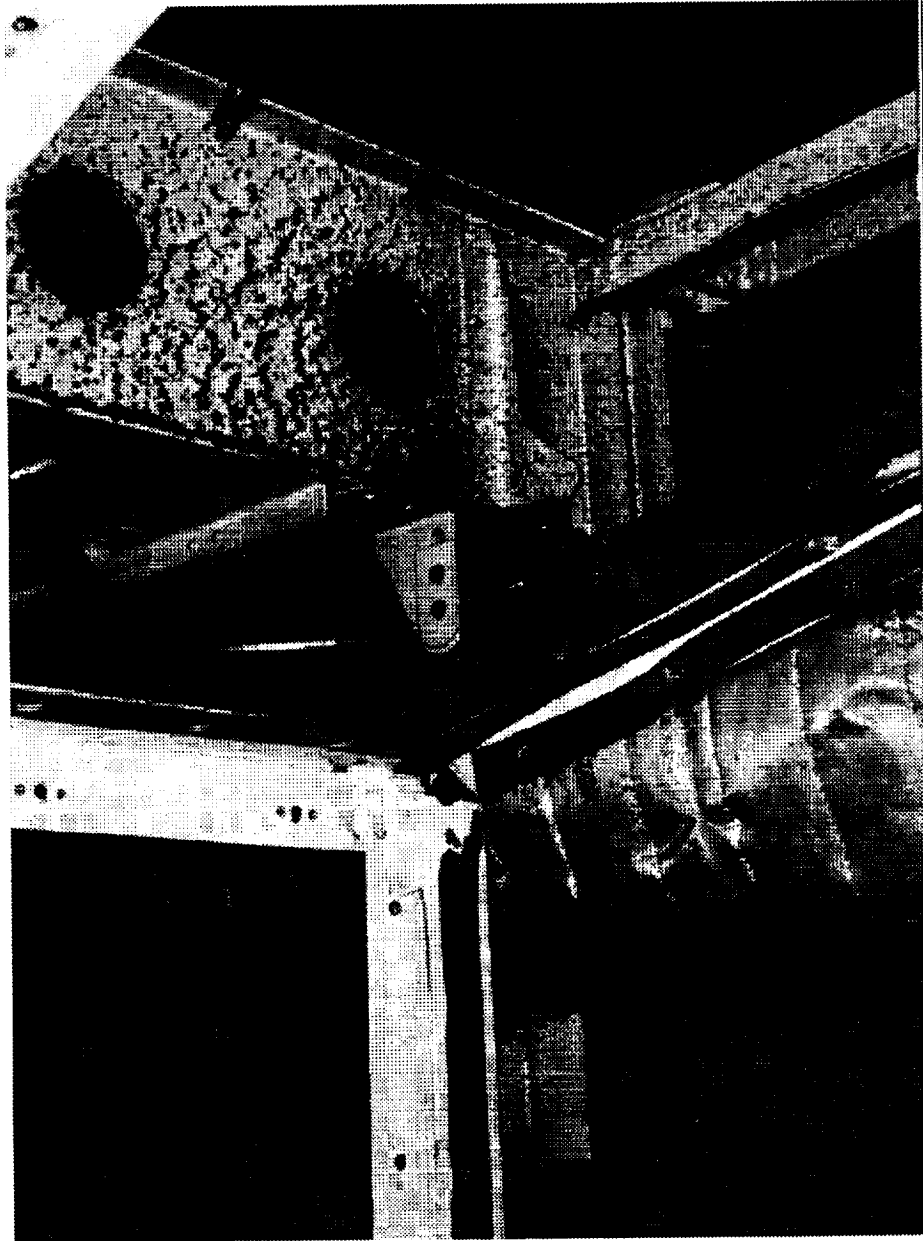

Figure 5.6-1. 757 Lower Lobe Dust Accumulations.

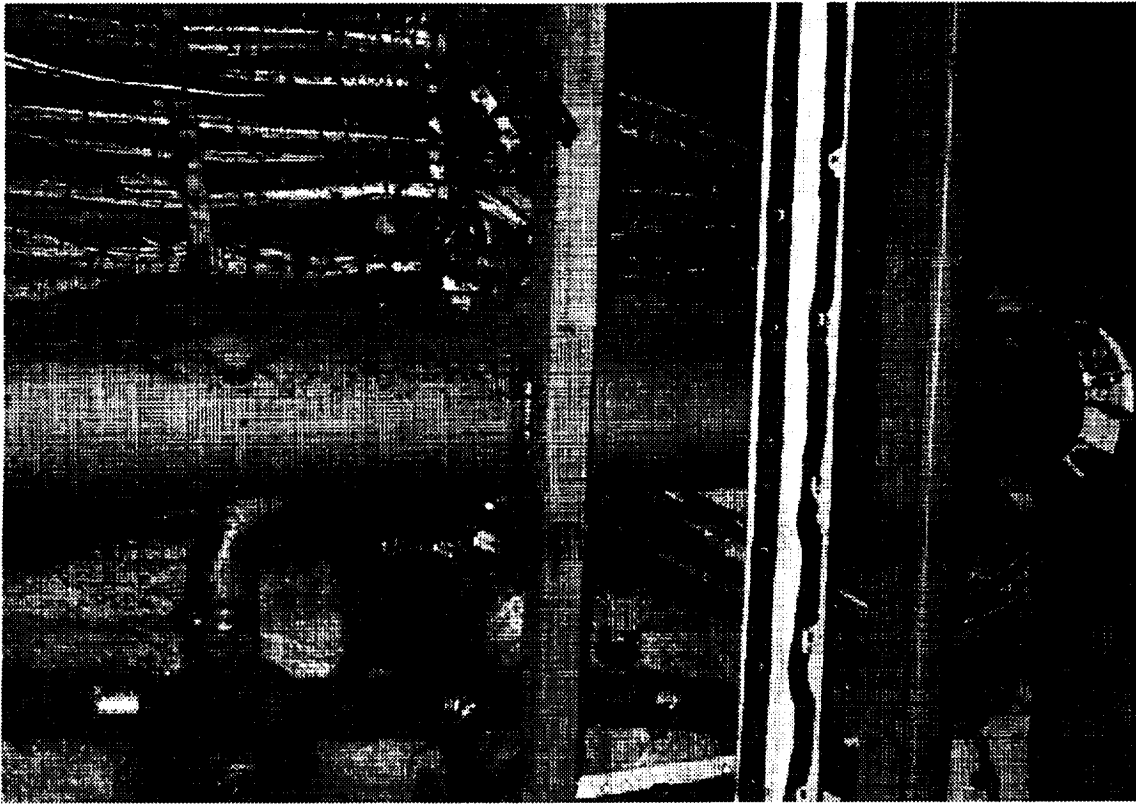

Figure 5.6-2. 757 Lower Lobe Dust Accumulations.

5.6.2.2 Doors

No potential structural or mechanical problems due to water are anticipated on the aircraft doors, since they are self contained and are not part of the stringer flow system previously described. Little water would enter the door structure through the internal liner or slide bustle cover, as these items provide a continuous cover over the inner door structure. Any stray water that did penetrate would be able to drain straight through and exit the bottom of the door. Water spray has not been considered to pose any significant threat to the aircraft's doors or door structure latching mechanisms.

Initially, some concern was expressed over the effects of water on the door mechanism. Freezing of condensation in the bottom of the lower gate has been a concern in the past, with difficulties opening the door after extended flights being reported. The additional water expected to drain into the vicinity of the escape slide girt bar from the passenger cabin following water spray could add to this problem. However, as demonstrated by the earlier reports, the emergency operation of the doors would not be affected.

5.6.3 Return to Service

In order to minimize long term corrosion effects to the airplane structure, any reconditioning program should begin immediately following the water spray event. The interior should be stripped, including all insulation blankets and floor panels, and the fuselage interior dried and inspected for clogged drain holes. The CIC application should be inspected and, if necessary, re-applied. The tops of the floor beams should also be inspected, and special attention paid to any areas that might collect water. The drain valves in the belly of the airplane will require inspection for clogging, and replacement as required. These valves (twenty-nine on a 757) are readily accessible from the outside of the airplane. The magnitude of the reconditioning process might be minimized by taking advantage of the "down" time and performing a complete "D" check at that time.

5.6.4 Mitigation of Disbenefits

Given current aircraft structural design and construction, there are no simple methods by which the disbenefits associated with the inadvertent activation of a water spray system might be eliminated, or even minimized. The effects of water will be insidious; it will migrate to wherever it's not wanted. Some consideration should be given, on new designs, to construction methods that will further minimize potential water traps. A more realistic recommendation would be to improve maintenance to ensure that debris accumulations, similar to those shown in Figures 5.6-1 and 5.6-2, are not present, allowing the existing drain paths to function as designed. This would certainly result in greatly increased maintenance costs to the aircraft operators, but might be the only reasonable alternative to significant changes to current design should a water spray system be implemented.

5.7 HUMAN FACTORS

The Human Factors aspects of cabin water spray discharge, both in the intentional and unintentional cases, were reviewed for potential disbenefits. Unlike quantifiable analyses reported elsewhere in this document, there is very little objective data that can be used to evaluate the impact of water spray on passenger behavior aloft or on the ground. Human factors considered everything of a behavioral, physiological, medical and psychological nature relevant to this concept. This section then, includes a great deal of speculation based on professional experience, and projections based on a review of the scientific and anecdotal literature of actual emergencies/accidents for clues as to the probable behavior in such situations.

5.7.1 Introduction

The installation of a cabin water spray system in a commercial jet aircraft is intended to provide additional evacuation time for the passengers, delay the combustion of cabin materials, and thus the toxic products of combustion, in the event of an external fire situation. Inadvertent activation of a water spray system, whether inflight or on the ground, poses potentially serious consequences to passengers and crew. A "worry list" of human factors concerns in the event of water spray deployment is presented in this document. This list is not necessarily complete and it is certainly speculative; most of these factors cannot be objectively quantified. Among the factors we have identified as of most concern are:

- Environmental conditions, which may cause slips, falls, obscured vision, etc. These items must also be considered in the inadvertent activation case, with the potential for injury they introduce.
- Potential for inhalation of water droplets after the "washing" effect has caused them to absorb the constituents of toxic gases, and the effect this will cause when taken straight into the lungs (Reference 3).
- Physiological stress, such as hypothermia and physical exertion, which may be too high for debilitated passengers if forced to evacuate in a cold climate.
- Disease caused postflight by environmental conditions and/or organisms which could proliferate in stored water. (The same microorganisms have potential for causing fouling and corrosion of the storage/distribution system).
- Psychological stress culminating in collapse, fainting, undesirable behavior or even medical conditions in susceptible individuals (e.g., heart attacks), if confronted with an inadvertent discharge inflight.
- Behavior of people upon activation of a water spray system. Will this system create a "panic" situation following inadvertent or ill-advised precautionary use, causing injuries where there should have been none?

5.7.2 Assumptions

By contractual agreement, only disbenefits of a cabin water spray system were considered. The study deals with a concept, not a system, since no operational hardware has been developed to date for inflight use. This was, by definition, a paper analysis only—no inflight or laboratory testing was authorized.

5.7.3 Consequences of Water Spray Activation

5.7.3.1 Evacuation in Emergency Situations

When considering the addition of a cabin water spray system to a commercial aircraft, there are two design requirements to consider: the effect that the water spray will have with inadvertent activation, and the resultant exit of the aircraft, and, the effect on an evacuation in a real fire emergency.

Many “precautionary” evacuations of commercial aircraft take place on a yearly basis. Cabin smoke, engine fires and other incidents dictate a cautious approach to passenger safety, which often means treating the incident as potentially life threatening, and exiting the aircraft as quickly as possible, often by the escape slides. There is a potential for injury in these evacuations, but it is considered an acceptable risk, since, in most cases they are purely precautionary, and take place in close to ideal conditions.

The wetting of the cabin interior by a cabin water spray system, however, adds a new element to this type of evacuation. Slippery conditions, as might be expected following water spray, will likely increase evacuation time. Leather soled shoes and other types of footwear may be especially susceptible to slipping on wet carpet. Since it is entirely likely it could be impossible to “disassociate” a water spray discharge from a fire emergency in the minds of the passengers, the pushing, shoving and crowding at the exits, combined with slippery conditions, might well increase the injury potential over what might currently be expected. Reduced vision, both from the water spray itself making emergency lighting difficult to see, and from the potential of wet eyeglasses, is another factor that will tend to slow down any evacuation. When combined with the potential for at least partial loss of lighting and passenger address systems, as might be expected from water damage (Section 5.3), a “precautionary” evacuation takes on a new level of passenger risk. This results in a negative safety gain over current aircraft configurations, and must be considered in any net safety benefit analysis.

In the case of the actual fire emergency, all of the above listed concerns are still appropriate, with one significant difference. All these factors may slow the evacuation process, which, in this case, could result in a greater loss of life (information from literature related to emergency evacuation is located in Appendix E).

5.7.3.2 Physiological and Medical Consequences of Water Spray Actuation

Reduced internal body temperature (hypothermia) can potentially occur under a wide variety of circumstances, both inflight and on the ground. Hypothermia is a likely consequence of use of a cabin water spray system, even if the system is activated on purpose when ambient conditions are cold. If the outside ground environment following evacuation is very cold, the shivering and high metabolic load imposed by hypothermia can lead to collapse, syncope, inaction, and, if persistent, death. Aged and infirm people may have inadequate or non-functional thermoregulatory reflexes. Reduced internal body core temperature is most likely to occur from cold outside air temperature, ambient wind chill, and inadequate clothing, but may also occur with substance abuse (alcohol, illicit drugs), fatigue, fear and other forms of debility. Obviously, soaking/wetting by the water spray system will aggravate the cold injury problem (Reference 4 and 5).

Cold injury is more rapid when convection is high as in cold conditions with a stiff wind. This carries heat away from the body more rapidly than in calm conditions and can rapidly lead to the signs and symptoms of hypothermia, including frostbite, frostnip, chilblains, etc. The well-known, readily available Sipple wind chill chart quantitates the physiological effects of temperature versus wind speed.

Disease is defined as aberrations to the internal environment (homeostasis) of an individual, i.e., deviation from health. An unplanned water spray event could trigger a variety of immediate and long term effects on passengers. Immediate psychological stress could lead to medical emergencies such as myocardial infarction (heart attacks), collapse and/or vasovagal syncope (fainting), etc. Post-flight effects of unwanted water spray might include colds, flu, pneumonia, etc., developing after an appropriate incubation period (depending on the organism and host resistance) after exposure to the stressful, cold, damp conditions water spray might provide. Healthy people may miss time from work, etc., whereas infirm people may contract potentially life-threatening disease.

The long term storage of water aboard the aircraft that water spray might demand creates additional concerns. Microorganisms growing in a stored water supply and/or in the distribution system could transmit disease if sprayed on people. For example, *Legionella p.* (bacterium which causes Legionnaire's disease) has been reported in the humidifier reservoirs of some aircraft. Colonies of bacteria will grow in enclosed water storage systems, especially when the water is not circulated or replenished.

Biofilm growth poses potentially serious corrosion risks to the storage tanks which in turn could adversely affect personnel. Choice of materials for storage and distribution of water must include evaluation of the potential for microbial influenced corrosion and contamination (Reference 6 and 7). Various biocidal agents may prevent or at least delay this problem but may in themselves prove toxic to humans and/or corrosive to materials. This may necessitate frequent system water change-outs and/or sampling of the stored water for the presence of microorganisms. Microbial biofilms have the following potential consequences in a water-storage system:

- Disease in susceptible people (pathogenesis);
- Corrosion of containers, pipes, spray jets, etc., and;
- Fouling of the system.

Microbial films are known to thrive even in nutrient-deficient "pure water" in metal containers(Reference 8). Some species are resistant to biocides such as iodine and become more resistant with time to biocides (Reference 9).

Given the modern aircraft cabin, the possibility of electric shock is something which should not be overlooked. Severity of symptoms depends upon many factors including type of current (ac/dc), level, grounding, duration of exposure, physical conditions of human, etc. Its effects include startle, muscle spasms, muscle contraction leading sometimes to fractures or dislocations, respiratory paralysis, cardiac arrest, and loss of consciousness. Severe levels of electric shock, although not likely here, can cause death, especially in debilitated people (Reference 10).

5.7.3.3 Psychological Aspects of Emergency Evacuation

Hysteria can be caused by real or imagined life-threatening situations such as could occur in inadvertent water spray activation. Hysteria can be precipitated by feelings of helplessness, what-to-do feelings, and claustrophobia from the rapidly changing cabin environment brought on by the sudden surge of water. "False alarm" emergencies have caused passengers in some aircraft to initiate evacuation when not specifically directed by the flight crew (Section 5.8.1.3). The severity of this reaction could be lessened by strong leadership on the part of the flight crew and/or passengers. It could be worse in, for example, a night inflight activation situation when the lighting system fails. Water spray jets may also cause a high-frequency, high-decibel sound which could cause the startle reaction, disorientation and possibly temporary hearing shift (deafness).

5.7.4 Mitigation of Disbenefits

If a cabin water spray system to suppress fire flashover is to be installed in commercial airliners the following human factors should be considered:

- Assure augmented and thorough training for flight attendant and flight deck crew (Section 5.8) as follows:
 - “Crowd control” training to prevent panic and hysterical reactions when the system is used intentionally or inadvertently;
 - Realistic training and personally experienced effects of water spray system deployment;
 - Complete knowledge of the cabin water spray system;
 - Frequent refresher training re: cabin water spray system (frequency period - TBD);
- Prevent micro-fouling by microorganisms in the storage and distribution systems through use of frequent sample analyses, selection of appropriate biocidal agents, and maintenance/replenishment of water;
- Consider type of materials for fabrication of the storage/distribution system regarding biofilm growth, corrosion, resistance to biocides, etc.;
- Consider source of water when replenishing water in storage tanks. In some parts of the world local water supplies may be so contaminated as to be not suitable for this purpose (or the potable water and humidifier reservoir).

5.7.5 Summary

A cabin water spray system is, by design, a safety enhancement for the protection of the aircraft's occupants in a fire situation. It is a human factors solution to the problem of fatalities due to a serious external fire scenario, and affords passive protection during the critical few moments of evacuation.

There are, however, some serious deficiencies in the work done to date in support of this system, and its effect on the occupants it is designed to protect. Any slowing of the evacuation process in a fire emergency, for reasons described in this section, will result in a system that is less valuable to the aircraft's occupants than the net safety benefit analysis claims it to be.

Concerns exist for the non-fire situation also. No component is 100% reliable, as evidenced by the redundancy required of all components critical to flight. As presented here, an inadvertent deployment of a cabin water spray system can cause serious problems for passengers. Hypothermia, post-flight disease from contaminated water, and the psychological stress from the unexpected discharge of water all demand attention and study to determine and quantify the effects on both the passengers and the net safety benefit analysis. As the CAA concluded when considering the use of passenger smokehoods (Reference 2), the addition of a safety system that may cause more fatalities than the system's ability to save is unacceptable. All factors must be investigated and tested to ensure that this is not also the case with cabin water spray.

There is a tendency to overlook the negative aspects of a system in the conceptual stages of design when early testing shows promise. This study was contracted for the purpose of exposing any “disbenefits” that a cabin water spray system creates that the controlled laboratory testing did not consider. As outlined, substantial human factors questions must be answered before this system is able to claim a positive net safety benefit.

5.8 FLIGHT DECK OPERATIONS

The determination of disbenefits in flight deck (and cabin) operations and procedures due to a cabin water spray system is a problematical endeavor at best. This is based upon the fact that: 1) there is no complete system design available for analysis, testing, and evaluation; and 2) there has not been extensive testing of the effects of cabin water spray on the avionics and other systems of a functional commercial aircraft. In this regard, conjecture or paper analysis of the likely effects simply is not sufficient to form a basis for the determination of the “fly-ability” of the subject aircraft. Until such tests are performed, the conclusions of this, and any other analytical review of the area, should be considered as hypotheses.

5.8.1 Inadvertent Activation

Inadvertent activation during flight is one of the most important, and potentially dangerous, scenarios for a cabin water spray system. The CWS system that has been proposed as the baseline for this study is not intended, nor designed, for use in fighting inflight fires. In view of the potential consequences if a cabin water spray system is activated inflight, there must be “fail, locked out” protection against inadvertent activation while airborne. The probability that this level of protection would fail and result in an inadvertent activation of the CWS system must, in combination with the probability that activation of the CWS system would cause failure of any critical components or systems, be no more than 10^{-9} in order to meet FAA requirements for protection against catastrophic failures.

5.8.1.1 Aircraft Diversion

Inadvertent activation of a cabin water system while the aircraft is inflight will most likely result in a diversion to a suitable alternate airport unless the destination airport is closer. The rationale for this is twofold:

- Even though it may be shown that there is only a small probability that the water/moisture from a CWS activation would cause failure of any flight-critical components or instrumentation, it is very likely that standard procedures for dealing with such an event would call for a flight diversion to the nearest airport. This view is based upon the potential catastrophic outcome of any common cause failure of redundant components, and given that the probability of such an occurrence would increase over time;
- It may be difficult, if not impossible, to determine immediately what caused the inadvertent activation. There would probably be at least an initial tendency of the passengers to believe that a fire had broken out. Even if the cabin crew can dissuade them of this fear, it is likely that the passengers will be anxious to get on the ground as quickly as possible, given their somewhat “damp” condition after exposure to the CWS system.

5.8.1.2 Loss of Flight Instruments

While loss of any flight instruments might be considered to be a disbenefit, it is the potential for loss of flight-critical instruments that is of serious concern. The analysis reported in Section 5.3 suggests that there is a low probability that any flight instruments will fail with a single activation of the CWS system. It should be noted, that while the probability of significant amounts of moisture reaching the E/E bay may be quite low, the FAR requirement for the reliability of flight-critical component functions is one-in-a-billion, or 10^{-9} .

In current designs, this level of reliability is reached by designs in which triple redundancy of many of the components reduces the probability of multiple failures of these redundant components to extremely low levels, assuming there is no basis for a common-cause failure source (Section 5.9). Cabin water spray systems appear to introduce such a source into the failure equation. It could certainly be hypothesized that if a moisture source resulting from activation of the CWS system acted to fail a certain component, it would have a fairly

high probability of similarly affecting adjacent or nearby components that are identical or of similar construction. In many cases, redundant components are positioned side-by-side, or at least located in near proximity. It is certainly credible that the probability of multiple failures of redundant components could be quite high under this scenario, assuming the initial failure takes place.

An example of this occurred in October of 1988 to the crew of a two-engine medium-large transport. Quoting from the crew's report:

"Just after lift-off (from Yakutat, Alaska), the fire bell sounded and all three fire lights (engines No. 1 and No. 2 and APU) illuminated. Ceilings were variable 600' to 1500' with visibility 2½ miles in fog and rain and a 10-15 knot wind out of the northeast. We immediately turned downwind, remaining in VMC, and landed uneventfully. The problem proved to be rainwater entering various control electronics boxes in the E/E bay. The water most likely entered through the forward entries and main cargo door area during turnarounds at stations where it was raining. The water seeps into the smoke vent/grille in the forward galley area and then down to the electronics bay. Water accumulates in a drain pan especially designed for isolating water intruding into the E/E bay, but the drains were plugged with dirt and debris, allowing the drain pan to fill (and overflow at aircraft rotation)."

This was a case where three like components failed due to a common-cause invasion of moisture into the E/E bay. Fortunately, the items that failed were not flight-critical. It is worth noting that even these failures caused an immediate turn-back to the airport.

5.8.1.3 Flight Crew Operations

The inadvertent activation of the CWS system while in either the takeoff or landing phases of flight would be the most important, and potentially the most disastrous, type of inadvertent activation, due to the high workload and critical timing of the takeoff or landing procedures. Any disruption or distraction from these procedures might result in serious, if not disastrous, consequences for the flight crew, the passengers, and the aircraft itself.

Because of the potential consequences of such distractions, many of the aircraft systems' caution and warning indications are inhibited during these phases of flight. Thus, even with fairly severe system failures, the flight crew is protected from the intrusion of the alerting indications of these failures during the critical segments of either a takeoff or landing. Only those failures which might affect the decision to continue or abort a takeoff or landing are presented to the flight crew.

Of paramount importance during these phases of flight would be the protection against the inadvertent activation of the CWS system. These phases are also the most difficult to provide with this protection, since the system must be "armed" at these times. As with the inflight phase, the design of the system must protect against inadvertent discharge to a probability of 10^{-9} . It will most likely require extensive simulator testing to determine what the procedural effects of a CWS activation during takeoff or landing would be.

An inadvertent activation of the CWS system would probably be dealt with in the same manner as many other system faults, i.e., the system failure indication would be inhibited during these two phases of flight, consistent with how other indications are likewise inhibited. It is likely that the event itself would not escape the attention of the flight crew, regardless of whether an indication is presented on the flight deck. The release of water spray, and the resulting reactions of the passengers and cabin attendants, may be impossible to hide from the crew. Thus, a very real threat to flight safety would remain if activation distracts or disrupts the crew during these critical phases.

Even an inadvertent activation of the CWS system on the ground poses some rather difficult decisions for the flight crew and cabin attendants. This stems from the fact that activation on the ground is an acceptable mode of operation, assuming there is a fire. The problem is one of determining whether the activation is due to a legitimate cause (fire) or is an inadvertent activation. This might not be so difficult if one could assume that some type of collision or other impact or obvious event would always be precedent to a fire event that would activate the system. Two decisions or duties resulting from the incorporation of cabin water spray are:

5.8.1.3.1 Decision to Evacuate

If it cannot be determined reliably that a "valid" fire condition does not exist, the activation would have to be treated as a legitimate event. Basically, this means the orderly evacuation of the passengers from the aircraft. This, in itself, must be considered a disbenefit if the cause is a "non-event", because evacuations very often result in injuries to passengers (Section 5.7).

Sometimes, the decision to evacuate can be taken out of the hands of the cabin attendants or crew. The following incident also illustrates the occasional panic that may be exhibited by some passengers in situations that may appear to be life-threatening, but are actually quite benign. Quoting Neil Santaniello of the Fort Lauderdale News and Sun-Sentinel, as reported in the Seattle Times (September 11, 1990):

"The first shout of "fire" came from a passenger sitting by the right wing of the Boeing 727, shortly after TWA flight 194 from Fort Lauderdale, Florida, touched down at New York's LaGuardia airport. Other passengers quickly joined in, yelling and pointing to flames shooting from an auxiliary power unit on the wing as the aircraft taxied toward the terminal Sunday night.

What happened next caught everyone by surprise: panicked passengers flung open emergency exits and bailed out. A few jumped from a wing onto the tarmac while the plane was moving, said passenger Lauren Rubel, 44, a New Yorker with a home west of Boca Raton, Florida . . . "everybody started to scream. Everybody went crazy," said another passenger, John Fontana, 60, . . . passengers said the captain left the cockpit briefly to tell passengers to sit down and not to panic. But "the people didn't give a damn anymore," Fontana said.

TWA officials called the evacuation an overreaction on the part of the passengers. The flames came from an auxiliary power unit that backfired, they said. "The passengers thought there was a fire, and they overreacted," TWA spokesman Jim Faulkner said from St. Louis. "The captain did try to communicate to them it was not a fire, but they had already headed for the doors." . . . A wave of "organized panic" then took over as other passengers left the plane, most of them sliding down four emergency chutes that were deployed. At least three passengers were injured."

5.8.1.3.2 Deactivation or Shut-off of CWS

If it can be determined immediately that the activation is inadvertent and unnecessary, provisions might be provided to manually shut-off the CWSS before it has completely exhausted itself. This would reduce passenger irritation and also reduce the cost of returning the aircraft to service.

5.8.1.4 Cabin Attendant Operations

Although there will be some routine activities required of the cabin attendants in case of an inflight activation of the CWS system, the potentially most demanding action will be to control the reactions of the passengers to the spray, to minimize behavior which might be disruptive or pose a threat to other passengers, the flight attendants, or the flight itself (Section 5.7). To the extent that an inadvertent activation of the CWS system disrupts the duties of the flight attendants, it would be considered a disbenefit to normal flight operations. The

degree of disbenefit would correspond to the seriousness or criticality of the procedures or functions that are disrupted by the CWS event. Most flight attendant functions are directed towards passenger comfort rather than safety-of-flight. Such disruptions would usually be at a much lower level of criticality than that affecting the flight crew.

Communications problems might be considered disbenefits of an inadvertent activation. A direct impact would result from failure of intercom or communications systems by water ingress from system discharge. The disbenefit would stem from the resulting increase in time and effort for the cabin crew to communicate with either the flight crew or with the passengers. An indirect communication disbenefit might result from the increased difficulty in all types of communications due to confusion following a system discharge. This could vary from a minor annoyance to a fairly serious disruption of normal communications. The last type of communications disbenefit is perhaps more hypothetical, but could be expected to occur with at least a small percentage of the flight attendants. This would be a consequent over communication with the flight crew in the aftermath of a CWSS event. Since the event is unexpected, and because the cabin attendants may not be prepared either procedurally or psychologically for dealing with such an event, it is likely that some attendants would fall back on the flight crew to provide guidance and instructions on subsequent actions. While this would affect the actions and effectiveness of the cabin attendants, the more serious disbenefit would likely be to the flight crew who is distracted and interrupted by the calls from the cabin attendant(s).

5.8.2 Commanded Activation

“Commanded activation” means the CWS system has been intentionally activated for its designed purpose. This activation could be either via an automatic system which senses the conditions that are necessary and sufficient to activate the system and then acts through pneumatics, electronics, hydraulics, or a combination thereof to activate the system, or it could be through the manual activation of the system by the flight crew, or perhaps by the cabin attendants. The pros and cons of these various types of activation methods, and their potential disbenefit effects on crew operations and cabin attendant procedures, are discussed in the following section.

5.8.2.1 Flight Crew Operations

Disbenefits to the flight crew will be dependent upon the arming/activation/operation scheme that is chosen. Various manual and automatic sequences have been suggested, but it is clear that the least disbenefits to the flight crew will come from the system that requires the least action on their part. It is inappropriate to comment on the various sequences that have been mentioned to date other than to reiterate that operation of any potential system must be fool-proof, working as intended only when intended, and invisible to the flight crew.

The success of a post-crash or fire event evacuation might depend upon successful communications between the flight deck and cabin crew. At the least, the evacuation could be delayed somewhat by any breakdown in communications due to water effects, as outlined earlier in this report. While many things might cause such a disruption, including CWSS activation, it is impossible to estimate its role without extensive testing in a functional aircraft. Even if communications are disrupted due to CWSS contamination, the disbenefit effect is likely to be on the order of only a few seconds of delay before the crew discover that they cannot communicate with each other. This would be a disbenefit only in the less destructive cases, where the airplane is left basically intact. In more extreme cases, the flight attendants may not wait for an evacuation command from the flight deck, nor attempt to communicate with the crew prior to initiating a passenger evacuation. Thus, this type of disbenefit should be considered of minimal importance.

5.8.3 Testing Requirements for Determination of Crew/Cabin Disbenefits

Many of the potential disbenefits to crew or cabin operations or flight integrity can only be ascertained by extensive testing of the effects of CWS on avionics components and other airplane systems in a fully functional aircraft. Some tests might be done at the component level to determine susceptibilities, and to isolate the primary drivers that might result in significant disbenefits. These tests would include such things as susceptibility

of various LRUs to moisture (in various forms) and pathway tests to determine where the water is likely to run under various configurations and airplane attitudes.

It would be useful to look for both immediate and long-term effects of moisture contamination on avionics since the latter could have significant return-to-service impact, or, if not reconditioned (dried out and repaired), might result in serious future failures of these components.

In order to determine the probability of various avionics failures, and what effects these might have on controllability of the aircraft, tests need to be performed which involve a fully functional avionics suite, with the ability to simulate various airplane attitudes.

Testing of the type described above can determine, to some extent, the likelihood of various avionics components or systems failures and false indications after the CWS system has been activated. There is no known comparable test that could determine what the behavior of passengers, attendants, and crew would be after such an event. The best indicators are the actual behaviors exhibited in similar situations. To the extent that a CWS event emulates some or many of these historical events, some relevant indications might be gathered from these past events. In addition, a "mock-vanilla" evacuation test might be run in which a CWS system was used without prior warning of the participants. Tests of this type are currently being considered by the CAA and the Cranfield Institute in the UK and may shed some light on the question of passenger behavior after an inadvertent activation of the system.

5.8.4 Mitigation of Disbenefits

A reduction in the disbenefits of cabin water spray from the flight deck operations perspective may be achieved with the following steps. First, flight and cabin crews must be given thorough training in the rationale, the operation, and the benefits of cabin water spray. Re-training at appropriate intervals must also be considered, since, in all likelihood, many crews will never see a situation requiring its use, nor will they experience an inadvertent activation. Second, flight deck operations, to assure the continued safe flight and landing of the airplane, even after inflight activation of the system, cannot be compromised. This dictates that essential airplane systems and controls must work, with whatever changes for "water hardening" of components and systems being designed and implemented. This also means, that the flight deck crew must not be burdened by activities outside the flight deck while control of the airplane is paramount, which leaves the cabin crew to attend to whatever situation the water spray has caused there, including control of the passengers under what might be very unpleasant conditions. Lastly, consideration should be given to what, if any, briefing is given passengers on the water spray system, including what to expect if the system goes off, and to rely on the direction of the cabin crew for their next step.

5.9 PRODUCT SAFETY

5.9.1 Introduction

Aircraft safety systems are designed to be independent from other aircraft systems, and to not adversely affect the operation of other systems or the airplane. Older technology aircraft are more mechanical and less electronically sophisticated. Systems were independent and were monitored by the crew, with interface accomplished by means of manual controls. More recent aircraft have sophisticated interfaces between systems that monitor and control functions without human input, and at very high speeds. The discharge of a cabin water spray system into this sophisticated electronic environment could, without significant upgrades to other systems and components, introduce a potential for complex systems malfunction that would jeopardize the continued safe flight of the aircraft, and put its passengers at an unacceptable level of risk. The following sections describe the anticipated disbenefits and effects on aircraft safety systems and philosophy.

5.9.2 Common Cause Failure

The commanded or inadvertent activation of a cabin water spray system introduces a potential “common cause” mode of failure for which all systems and components must be evaluated. Current system architecture allows primary and secondary LRUs for many systems to be co-located (Figure 5.9-1 and 5.9-2). Rationale for this has always been that both units would not be at risk from the same threat. However, the presence of water, and the uncertainties of the water paths which would result after discharge, introduces a potential for both units to be damaged by the same flow of water at the same time, since their original location selections were not made considering this type of threat. This is defined as the possibility of common cause failure. The potential for common cause failures, and their implications on the safety of the aircraft and its occupants, dictate they be made a highly improbable event ($< 1 \times 10^{-9}$) through increased component protection against the threat of moisture, and through isolation of redundant components by both location separation and increased compartmentalization. Additional measures would include an enhancement of the moisture protection of current designs, decreasing the probability of moisture reaching critical components by increasing the moisture absorption capability of the air-conditioning system, cabin carpets, drain tracks, drip pans, etc. The many scenarios for multiple failures and the separation requirements to prevent them will not be addressed in this study, since any serious consideration of the adoption of cabin water spray must address this problem on a more global basis, designing the layout of critical equipment accordingly.

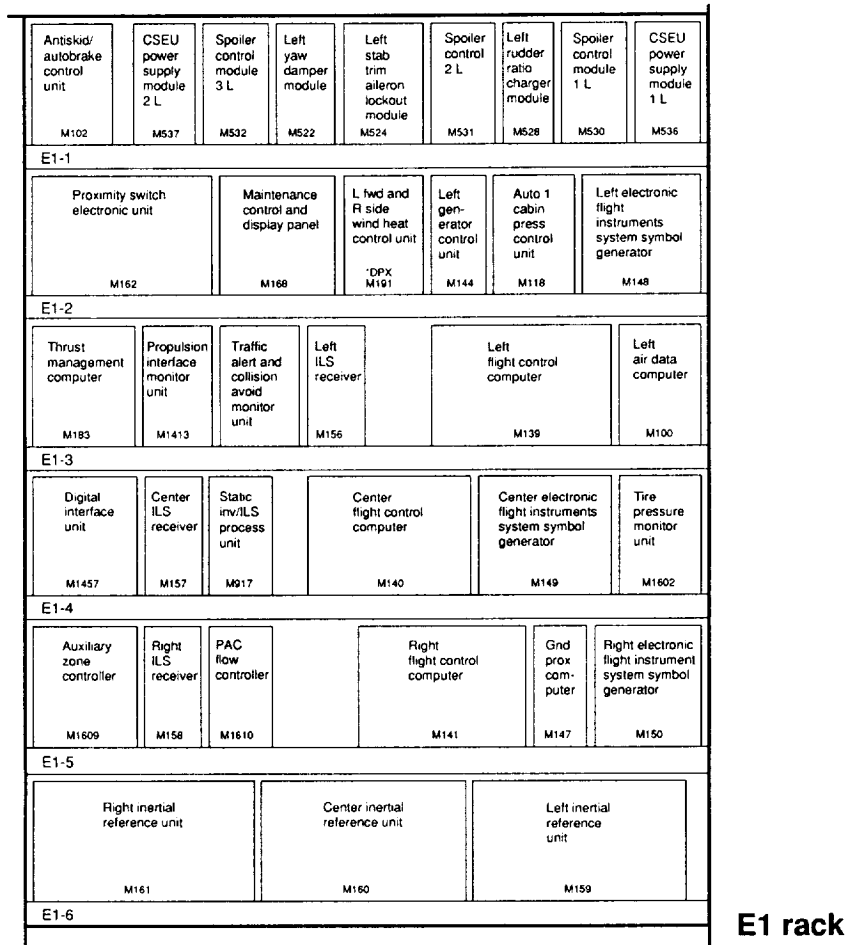

Figure 5.9-1. 767 Front View Main Electrical/Electronic Racks.

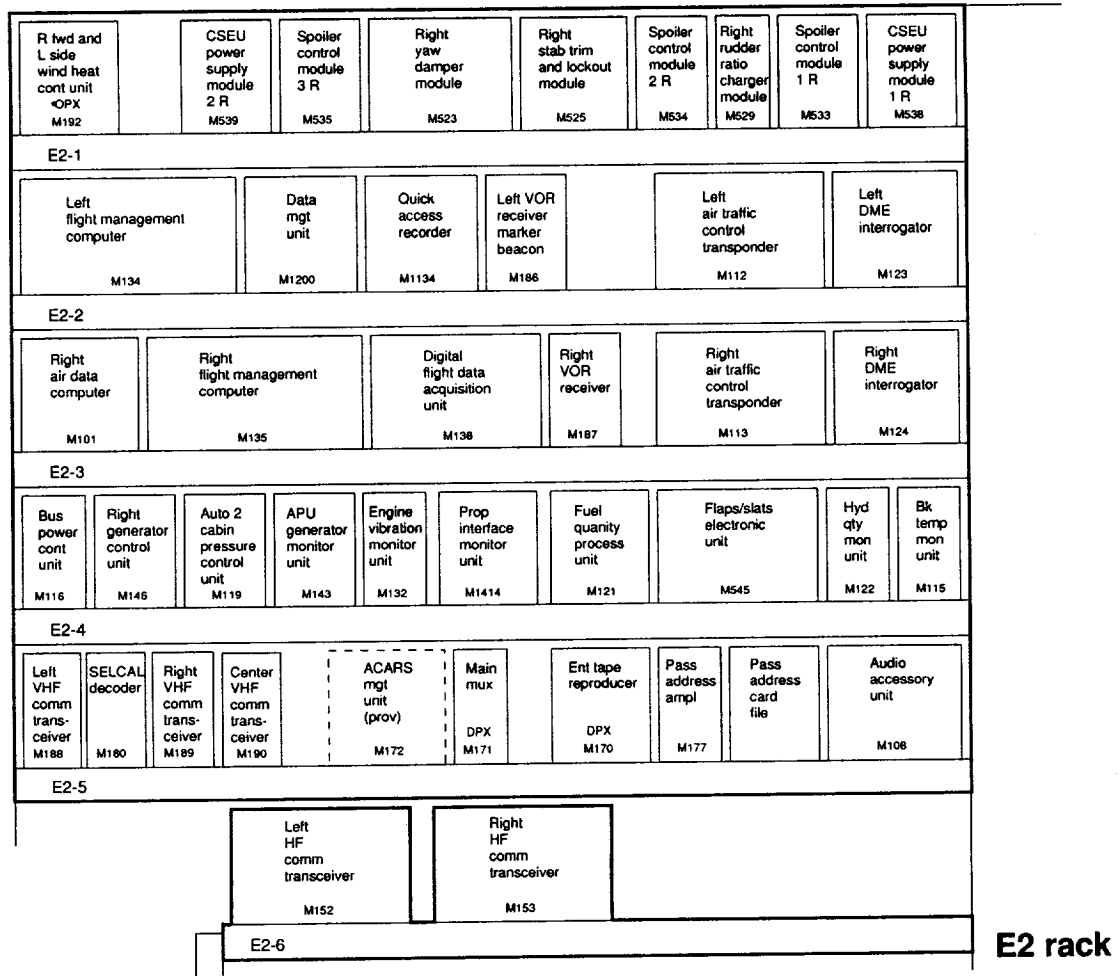

Figure 5.9-2. 767 Front View Main Electrical/Electronic Racks.

5.9.3 Safety-of-Flight Critical Equipment

Since a cabin water spray system could affect multiple systems concurrently (Section 5.9.2), research was conducted to determine which equipment on current aircraft is critical for **continued safe flight and landing**. AC 25.1309-1A states the following criteria for continued safe flight and landing:

“The capability for continued controlled flight and landing at a suitable airport, possibly using emergency procedures, but without requiring exceptional pilot skill or strength. Some airplane damage may be associated with a failure condition, during flight or upon landing.”

Research involved identifying the systems and equipment that the flight crew would need without requiring exceptional skills. In order to accomplish this, failure conditions and their severity classifications were reviewed. According to AC 25.1309-1A, a failure condition is:

“The effects on the airplane and its occupants, both direct and consequential, caused or contributed to by one or more failures, considering relevant operational or environmental conditions.”

The failure condition severity classifications are:

- Minor – Failure conditions which would not significantly reduce airplane safety, and which involve crew actions that are well within their capabilities. Minor failure conditions may include, for example, a slight reduction in safety margins or functional capabilities, a slight increase in crew workload, such as routine flight plan changes, or some inconvenience to occupants.

- Major – Failure conditions which would reduce the capability of the airplane or the ability of the crew to cope with adverse operating conditions to the extent that there would be, for example, —
 - A significant reduction in safety margins or functional capabilities, a significant increase in crew workload or in conditions impairing crew efficiency, or some discomfort to occupants; or
 - In more severe cases, a large reduction in safety margins or functional capabilities, higher workload or physical distress such that the crew could not be relied on to perform its tasks accurately or completely, or adverse effects on occupants.

- Catastrophic – Failure condition which would prevent continued safe flight and landing.

The complete failure of the electrical system is considered to be a major failure in our current aircraft designs. In order to prevent a catastrophic failure, and compromise continued safe flight and landing, the functionality provided by the **standby power system** and the equipment powered by this system is required to remain operational. This level of criticality must be maintained after inflight discharge of a cabin water spray system.

Tables identifying the equipment currently powered by the standby power systems of the 737, 747-400, 757, and 767 airplanes are included in Appendix B. These tables outline the minimum required functionality of the electrical power systems for continued safe flight and landing, and help define the equipment which must be “hardened” to assure that failure which might result from a cabin water spray discharge is a “highly improbable” ($< 1 \times 10^{-9}$) event. This equipment is not currently designed or located considering the threat posed by a water spray system.

5.9.4 Discharge Consequences

For obvious reasons, the worst case for an unintentional discharge of a cabin water spray system is during takeoff, cruise, or landing. Cruise implies that the aircraft could be a significant distance from a suitable airport, should a system failure require the aircraft be landed at the first opportunity. The takeoff and landing phases of flight produce the highest crew workload, and are the least tolerant of unnecessary distractions or incorrect information to the flight crew. Any incorrect or improper signals or system failures, or combinations of both, can have serious repercussions.

The 1989 Kegworth crash of a British Midlands 737 might be used as an example. An engine failure on this airplane, followed by the inability of the crew to recognize which engine had failed, resulted in a fatal accident. Section 5.4 indicates that water ingress into the EEC channel select and fuel shut-off circuitry could, in its worst case, result in a main engine reverting to idle thrust. Elsewhere, in Section 5.3, the predicted results of water ingress into various other electronic components are incorrect and sporadic cockpit indications. These two conditions, while unlikely, illustrate the threat to sophisticated electronics posed by water when elaborate protective measures are not included. The extrapolation to a compromise of the safety of the airplane and its occupants is not unreasonable.

5.9.5 Mitigation of Disbenefits

In order to assure an equivalent level of safety with the introduction of a cabin water spray system, a number of significant changes to aircraft design would be required. As mentioned in other sections of this report, the incorporation of such a system would require the reevaluation of all other critical systems in the airplane in view of the threat that water poses.

Current layout of critical system components in the electronics bays would need to be revised to eliminate common cause failure potential. This might mean redistribution of LRUs and/or water hardening of all equipment and connectors to eliminate the danger of electrical shorts and equipment compromise. An alternate approach might be to redesign the environmental control system such that moisture laden air flow to the electronics bays is stopped upon initiation of water spray discharge. In any event, a comprehensive and rigorous testing program would have to be developed and imposed at the component supplier level to assure that whichever approach or combination is taken produces the necessary results.

It is not the intent here to outline all changes which might make the incorporation of cabin water spray suitable for aircraft use. Rather, it is clear that any work in this direction must be undertaken at the global level, recognizing the environment that is created and in which other systems must continue to operate.

5.9.6 Summary

The introduction of a cabin water spray system is not a simple, add-on system. Water spray introduces major changes to the operating environment of the aircraft's systems, and to the occupant's environment as well. While a water spray system can certainly be added to today's sophisticated aircraft, from a technical perspective, it must be done such that the CWSS achieves the goal of increasing passenger safety and not detracting from it.

5.10 RELIABILITY AND MAINTAINABILITY (R&M)

5.10.1 Introduction

This study considered a concept, not a mature system, and no operational hardware has been developed to date for inflight use, therefore, only limited reliability analysis has been performed. Investigative work performed by R&M is of a very generic nature and describes what would be required during development of a cabin water spray system. R&M impact and program requirements would be different for existing in-design and production aircraft in relation to future design programs. While new design programs would be significantly impacted by including the CWSS, any retrofit programs would have a much larger R&M impact.

5.10.2 Reliability

5.10.2.1 New Designs

A commercial jet aircraft is certified as the sum of its parts, in recognition of the fact that an anomaly in any of the systems in the aircraft can have a significant impact on other systems. From a design standpoint, any system to be incorporated into the aircraft is better identified sooner than later, since the analyses performed to satisfy the certification process are lengthy and dependent upon projected failure mechanisms, and the overall aircraft's ability to tolerate a failure, while maintaining safety-of-flight. These analyses must cover both operation of the water spray system, to assure it will work when required, and the potential impact to other systems in the aircraft, for all aircraft attitudes, in both commanded (systems required for safe evacuation must be protected) and inadvertent (control of the aircraft, inflight and on the ground must be maintained) scenarios. The following is a basic listing, by no means complete, of the types of analyses which must be performed considering the effects of a cabin water spray discharge:

- A comprehensive FMECA of all systems and components that would be affected by the CWSS;
- Fault tree analysis of all systems and components that are considered critical. In addition, a higher level fault tree would be needed to determine if systems and components impact or interact in new ways not previously considered before the water spray concept;
- MEL dispatch versus potential failure mode analysis of remaining systems. It cannot be assumed that all systems are 100% functional, and failure tolerant components, hidden failures, and inoperative or degraded components may no longer provide the required safety margins;
- Degradation analysis;
- Reliability tests and demonstration programs;
- Potential sneak circuit analyses;
- Reliability predictions;
- Selected parts review.

5.10.2.2 System Retrofit

Assessing the impact of a CWS system on existing aircraft reliability is a difficult proposition. None of the systems or components in current build aircraft were designed, specified, constructed or certified considering a potential water spray environment. In addition, since cabin water spray is presently only conceptual, and not designed or used on any aircraft in service, no existing data base for failure rates and in-service impact are available. We do know that a minimum reliability number is needed to provide the required degree of safety for all systems, especially safety-of-flight systems and components. There are over 50 critical systems requiring a 10^{-9} probability of failure, and at least as many essential systems requiring a 10^{-7} probability to be considered.

In order to achieve this required level of reliability and analysis confidence, all components and systems that may be impacted by water spray will require re-analysis of all previously conducted fault trees, reliability analyses, specification requirements, MEL analyses, and safety analyses, which were used for certification. This includes all those done by Boeing, as well as those done by the component subcontractors. For example, an analysis showing system redundancy, which allows dispatch with one component inoperative, may not allow dispatch with the introduction of a potential water spray system discharge. The additional fault introduced into the fault tree(s) and FMECAs may show that without system design changes there may be a criticality impact that would require a change to the MEL. Similar analyses for all components and systems may also show safety degradation requiring redesign and/or operating procedural changes. Here also, as with new designs outlined above, these analyses must cover both operation of the water spray system, to assure it will work when required, and the potential impact to other systems in the aircraft, for all aircraft attitudes, in both commanded and inadvertent scenarios.

5.10.3 Maintainability

Given that this is a concept study only, with no proposed system design, only a listing of potential maintainability impacts are presented, and in general terms. The maintenance impact of some in-service water spills into the aircraft's E/E bay and the passenger cabin have occurred and these can be evaluated for similarity to an inadvertent CWS discharge (Section 5.1.2).

Additional information regarding inadvertent discharge cost and a detailed return to service analysis is also found in this report (Section 5.11).

Airline in-service water intrusion into the E/E bay due to water spills and lavatory overflows have resulted in the removal of electronic components, drying of racks and surrounding structure, application of water displacement agent, and reinstallation of replacement electronic components. Aircraft have required a check flight prior to return to revenue service. The removed components were returned to the over-haul shop for cleaning, test/repair, and then put into spares. This airline procedure, for any accidental water spills that result in wet avionics in the E/E bay, would certainly be no different with an inadvertent CWSS discharge.

The following is a partial list of studies and analyses that would be required for the incorporation of a cabin water spray system:

- A reevaluation of existing maintainability analyses and studies for all systems and components that may be affected;
- Maintenance tasks that will be required for safe ferry to an overhaul base from a remote station;
- Maintenance impact of all interior furnishings and equipments that are changed – accessibility, manuals, training, procedures, checkout, etc.;
- Inspections – changes, additions, when, where, tests and test equipment needed, how many mechanics, training requirements; for both the CWSS and changes to other systems and components, etc.;
- Functional checkout procedure changes of redesigned systems and components;
- Inspection and maintenance cost to the carrier;
- Inadvertent discharge cost;
- CWSS maintenance installation error probability;
- CWSS component accessibility;
- Potential incorrect servicing, installation, repair, testing of the CWSS;
- Demonstration requirements to assure the system works in-service, after maintenance, aging fleet considerations, during certification, etc.

Other topics that arise during design need to be considered, such as combi aircraft installation requirements. Further analysis will bring forth additional design and operational considerations that will have to be evaluated in addition to the above.

5.10.4 Summary

It cannot be over emphasized that the systems and components of in-service aircraft were not designed to be fault tolerant of water intrusion due to water spray system discharge. This potential was not included in specification requirements, fault tree analyses, system and component designs; not in any design consideration or concept. In order to ensure that any retrofit of these aircraft does not compromise safety-of-flight, this new system will require extensive testing to eliminate the potential of inadvertent discharge, and will also require a review of every conceivable and demonstrated water flow path throughout the aircraft, and the subsequent impact on all systems and components in the event of an inadvertent discharge. It would require a review of not only relevant maintainability, reliability, and safety studies and analyses, but also a consideration of how a design might have evolved had the designer known that there was a possibility that water may be sprayed into the cabin.

5.11 RETURN TO SERVICE

The possibility of an inadvertent water spray activation, and its consequences, have been discussed at length in many sections of this report. This previous discussion has addressed the subject from the functionality point of view, i.e., will the systems in the airplane continue to function and allow continued safety-of-flight or uninterrupted control in the taxi, takeoff, cruise, or landing phases of flight. This section will attempt to quantify the time and cost to return the aircraft to service following an inadvertent discharge.

5.11.1 Assumptions

Damage to the airplane is assumed to be limited to that caused by the water, with no collateral damage from external sources. This means the airplane has made a successful landing, and come to a safe stop with no loss-of-control.

The process of refurbishing the airplane is assumed to begin immediately, thus not allowing corrosion to begin in places where water might be trapped. The "return to service" refurbishment assumes the aircraft is returned to "like-new" condition, since the unintentional discharge has occurred in a new airplane. The refurbishment process is assumed to take place at the aircraft's maintenance base, minimizing any logistics issues that might require consideration if the aircraft is immobilized elsewhere. Costs to ferry an aircraft to its maintenance base could be substantial, but these costs, as well as the revenue lost while the aircraft is out of service, are not included in the refurbishment cost estimate.

Finally, all estimates of refurbishment costs include only the time and materials required to repair and checkout the aircraft following the water spray event, and any parts requiring replacement are assumed to be immediately available. No consideration has been given to incidental costs such as legal fees, passenger related expenses such as cleaning bills, damaged luggage, etc., or logistics costs which might be incurred after an aborted flight.

5.11.2 Discussion

The projected refurbishment of a 757 following water spray discharge was begun with a listing of equipment, systems and furnishings by ATA chapter. This listing of chapters and codes was reviewed by the appropriate Boeing functional organizations for expected damage from water, and formed the basis of the Delta Air Lines investigation. The ATA chapters and costs associated with refurbishment may be found in Appendix C.

Upon identification of the components/systems expected to be wetted, whether directly or indirectly, each item was reviewed for the impact water is expected to have on that item. Although the quantity is not necessarily comparable, liquid spills on airplanes are not new, and lessons learned from those events have been used for this review. Where past experience has shown that items exposed to water may be successfully cleaned, only labor for removal, cleaning, and re-installation are considered. A percentage of those items that are judged to be susceptible to permanent damage is assumed to require replacement, and material costs are added for those items. The Delta estimates are subjective, but represent a best guess estimate, based on operational experience and the evaluations made by the Boeing functional organizations, especially from an electrical/electronic systems refurbishment standpoint. Those items which might impact the airlines' image requirements, or where operational experience has demonstrated that drying and cleaning leaves a less than adequate appearance are assumed to be replaced, and full material costs quoted. Damage is considered to be "worst case", and to have taken place on a new airplane, thus all reconditioning is done with the intent of bringing the airplane back to "like-new" condition immediately, for reasons stated in Section 5.11.1.

In order to return the airplane back to "like-new" condition following a spray event, the recommendations of the Boeing functional organizations have been followed. The interior of the airplane would be removed, including floor panels, to eliminate trapped moisture and prevent the start of corrosion. Insulation blankets would be removed, for the same reason, and the degree to which these blankets have been wetted will dictate their disposition. Seriously wetted or saturated blankets will be replaced, as Delta's operational experience has shown that blankets which have been dried out do not perform the same as new ones. (Costs quoted in Appendix C are for complete blanket replacement, but this will be on an as required basis.) CICs would be re-applied at this stage, this being the best way to displace any remaining moisture from seams and joints, and ensure that the corrosion process is not allowed to begin.

Delta's experience with cleaning carpets and seat covers/cushions has shown shrinkage and impact on appearance to be severe enough that these items would require replacement, and are reflected in the cost estimates. Some relaxation might be possible here for an older airplane, but, as stated in Section 5.11.1, the "incident" is assumed to have taken place in a new airplane. All passenger cabin components are examined for water, and cleaned as required. Electrical items are dried and tested, with those that have shorted being replaced. General cabin illumination and passenger entertainment systems are considered vulnerable to failure from water ingress and short circuiting, and include material costs for replacing a percentage of the exposed units. These material costs are included in the Appendix C tables. (As an example, the 757 as configured for Delta Air Lines has 187 passenger reading lights. Approximately $\frac{1}{3}$, or 62, are assumed to fail due to water ingress, and must be replaced.) Door bustle mounted slide packs, that are within the designated spray area, are also inspected for the presence of water. This inspection is performed only when the slide has not been deployed, and the tabulated costs reflect that inspection only. Slides that have been deployed after water spray activation would require re-packing at a cost of \$1000 US per slide, with a total of 8 slides on the baseline 757. ECS equipment that has ingested water is inspected and dried as required. No material costs are expected for ECS equipment.

The reconditioning of the E/E bay is based on recognition of the safety level of the components located there. Equipment located in the E/E bay is somewhat moisture resistant due to flight safety considerations. All rack mounted LRUs would be removed, dried, cleaned as required, and given a functional test. Based on input from the Electrical group in Section 5.3, no LRU failures requiring unit replacement are expected, therefore costs reflect the labor for removal, cleaning, test, and re-installation tasks only. As discussed in Section 5.3.3.5, check-out and test in-place is not recommended. Moisture that is not eliminated can set-up destructive corrosion processes, as well as create a new malfunction situation when the aircraft assumes an attitude that causes droplets to collect at an undesired location, such as a terminal connection.

The experiences of Delta, as well as of other carriers, indicate that a comprehensive and aggressive refurbishment program following water spray discharge is required to minimize long-term impact to the airplane, and shorter term degradation of current high levels of safety. This program will be expensive, however, attempts to delay or eliminate any part will likely result in a short term savings at the expense of greater long term maintenance costs.

5.11.3 Summary

Based on a labor rate of \$50 US per hour, the estimated cost projection for returning a 757 to like new condition following inadvertent system activation is \$881,000 US. Breakdown by subject and ATA code is summarized in Table 5.11-1, while detailed backup documentation, as referenced above, is available in Appendix C.

Table 5.11-1. Labor/Cost Summary.

Subject	Labor	Cost*
ATA21	143 mhr	\$ 7,150
ATA23	1,230 mhr	142,400
ATA25	3,874 mhr	508,140
ATA33	714 mhr	133,800
ATA35	93 mhr	4,650
ATA51	132 mhr	7,300
ATA53	672 mhr	33,690
E1 rack	26 mhr	1,300
E2 rack	123 mhr	6,175
E3 rack	117 mhr	5,850
E4 rack	162 mhr	8,125
E5 rack	117 mhr	5,850
E6 rack	97 mhr	4,875
Panels	250 mhr	12,500
Total	7,750 mhr	\$881,800

* Totals include material costs and labor rate of \$50 US/hr

From a maintenance perspective, the inadvertent discharge of a cabin water spray system will create a significant cost impact. While it is most likely not possible to mitigate the costs associated with a refurbishment after discharge, the incorporation of this type system would dictate a revised maintenance schedule philosophy. The level of disassembly required for refurbishment is similar to that required for a scheduled "D" check, and are similar in cost as well. If close to the regularly scheduled maintenance interval, the "D" check requirements should be satisfied at this time as well. If the incident occurs shortly after the last check, the complete refurbishment will still have to be initiated, and the full cost burden to the airline will be realized.

6. SUMMARY AND CONCLUSIONS

Water spray systems, in the test scenarios conducted to date, have been effective in removing heat, and suppressing the generation of toxic smoke, by delaying the combustion of cabin furnishings. When examining the disbenefits created by the adoption of these water spray systems, one must keep in mind that the test vehicles used for the demonstrations of water spray technology are different in one very important respect from an operational aircraft so equipped; the operational aircraft must be able to provide continued safe flight and landing and must not be susceptible to any loss of control in the event of an inadvertent discharge, planned or unplanned, while on the ground or in the air.

The objective of this study was to determine the disbenefits that may be created by the addition of a cabin water spray system to a commercial jet aircraft, and what precautions would be necessary to mitigate damage that would be incurred following both commanded and uncommanded discharge. It is difficult, as many of the functional groups participating in the subject study have pointed out, to predict the outcome of the deployment of a system that exists only on paper and has not been fully designed nor tested in an aircraft. Water, containing ions and impurities, has demonstrated its corrosive and damaging effects in a multitude of in-service lavatory and galley spills. The very design and structural fabrication of an aircraft serve to trap and collect water

where it is least desired. Structural junctions at frames and stringers, shear ties, floor beams and intercostals all become collection points for contaminated water, and sources of corrosion, leading to weakening of the structure.

Modern commercial aircraft operate with very sophisticated electronic systems and controls. In evaluating the ramifications of electronic component and system failure that might result from moisture ingress, the individual functional engineering organizations have identified and described various situations that would be created by those failures. Moisture protection measures on existing aircraft are intended to minimize or eliminate the chance of failure in operational environments that include 100% humidity and visible moisture (condensation), but are not designed to prevent against the amounts of moisture that would be expected from a water spray discharge. Substantial protective measures that do not currently exist (waterproofing all electrical components and connectors, additional drip shields, increased drip pan capacities, enhanced cleanliness standards, etc.) would need to be incorporated to deal with this new type of water threat. Extensive testing of entire systems, possibly in a complete airplane, might be necessary and recommended to verify that the added protective measures will perform as designed. Reliability requirements for key safety-related components dictate a failure rate of less than 1×10^{-9} , and many of the failures postulated following the discharge of water spray could jeopardize that reliability, with potentially disastrous results.

But even the protective measures discussed in this report treat the problem of moisture ingress on a localized component level, whereas the water spray hazard must be addressed on a much larger systems scale. The Product Safety portion of this report (Section 5.9) discusses the potential for common cause failure, i.e., the failure of redundant systems designed to provide an additional margin of safety in the event of component or system failure. Very simply, the incorporation of cabin water spray introduces, in an aircraft's present configuration, a common cause failure source. The remedy for this is straightforward, but costly: components and systems in present day aircraft will need to be redesigned and relocated to eliminate water as a common cause failure source.

This study had the luxury of considering only new aircraft and was performed by the aircraft manufacturer who sees his products leave the production line as "factory fresh". While aircraft leave the factory in the as-designed configuration, the realities of day-to-day service often result in changes or modifications to the original design, or design intent. The Structures section (Section 5.6) of this report documented and discussed the dust and dirt accumulations present after a period of service. These accumulations will tend to entrap moisture and allow corrosion to begin at structural junctions which were designed to drain any liquid to the lower lobe and out of the aircraft. The Electrical section (Section 5.3) discusses dust contamination of printed circuit card connectors, and mineral content present in sprayed water, that may well overcome the safety measures normally designed to protect against high humidity, leading to electrical shorts and component loss. This does not imply that aircraft are made less safe by their operators, or become less safe after being in-service, however, the realities are that drain holes clog, drip shields are torn or discarded, wire insulation gets abraded, etc. These concerns, and others that will surely present themselves, will require careful consideration before any system that sprays water into an aircraft that experiences diverse operating environments can be made safe.

Summarizing, our conclusions for this study are as follows:

- CWS is a safety system that can negatively affect other key safety of flight systems, by creating a common cause failure source;
- Flight and evacuation critical systems will require detail review and potential major redesign to mitigate water damage;
- CWS may increase evacuation time;
- Evacuation into and prolonged exposure to a cold climate following discharge may be hazardous;
- All aircraft systems susceptible to water damage require detail review to minimize damage and return to service costs;
- The cost of returning an aircraft to revenue service following discharge is high;
- Passenger reactions to activation of water spray are unknown.

The remarkable safety record enjoyed by commercial jet transportation is a result of high standards of safety established by the regulatory bodies, the manufacturers, and the operators over the last 30 years. The incorporation of cabin water spray systems, though not without potential benefits, has the potential to compromise a hard-earned, and continuously improving, commercial aviation safety record. Any regulation requiring cabin water spray systems must be approached cautiously, with open minds to both the potential benefits and, perhaps, the more obscure dangers.

PAGE ~~64/65/66~~ INTENTIONALLY BLANK

Appendix A

Dimension Drawings

PRECEDING PAGE BLANK NOT FILMED

 PAGE 67/65/66 INTENTIONALLY BLANK 67

737-300 General Arrangement

PRECEDING PAGE BLANK NOT FILMED

PAGE 68 INTENTIONALLY BLANK 69

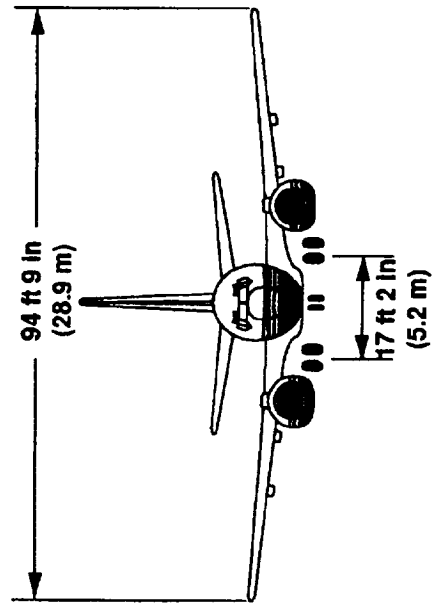
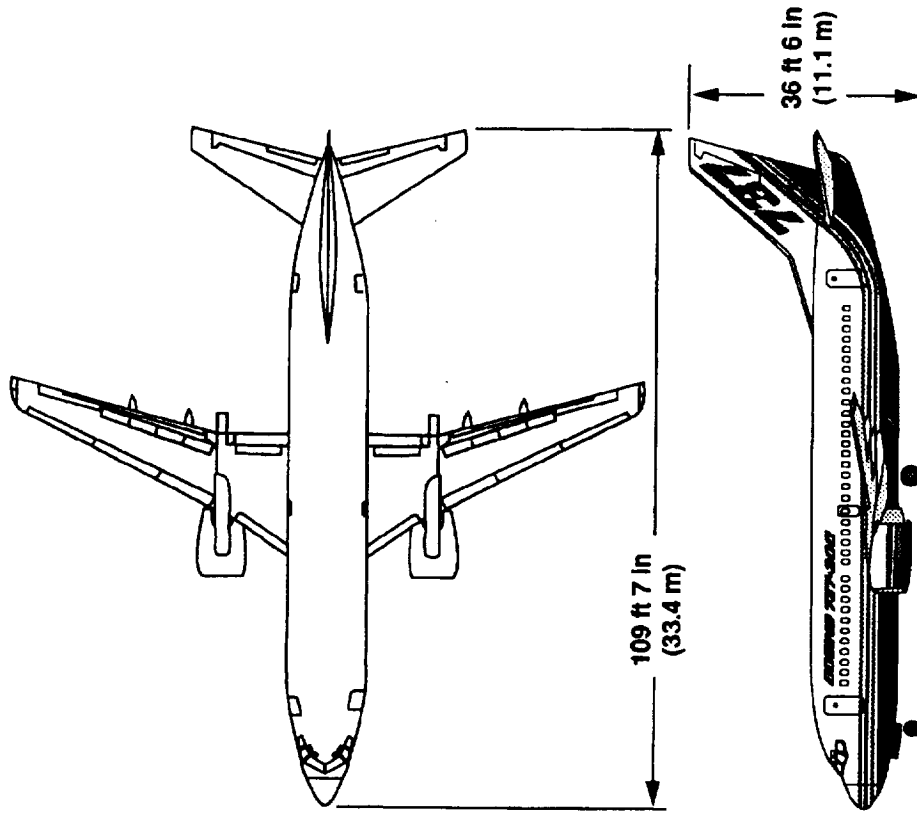

Appendix A-1

737-400 General Arrangement

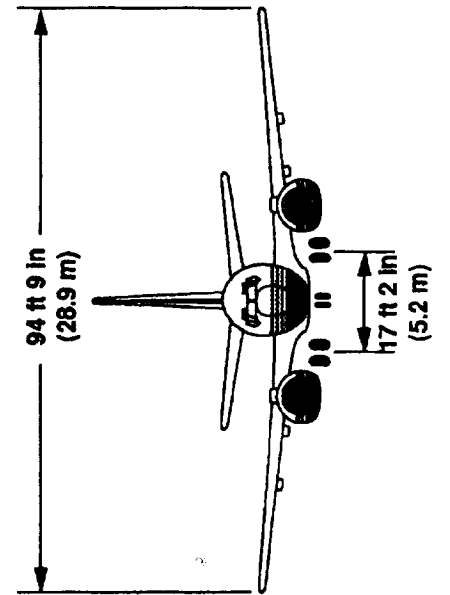
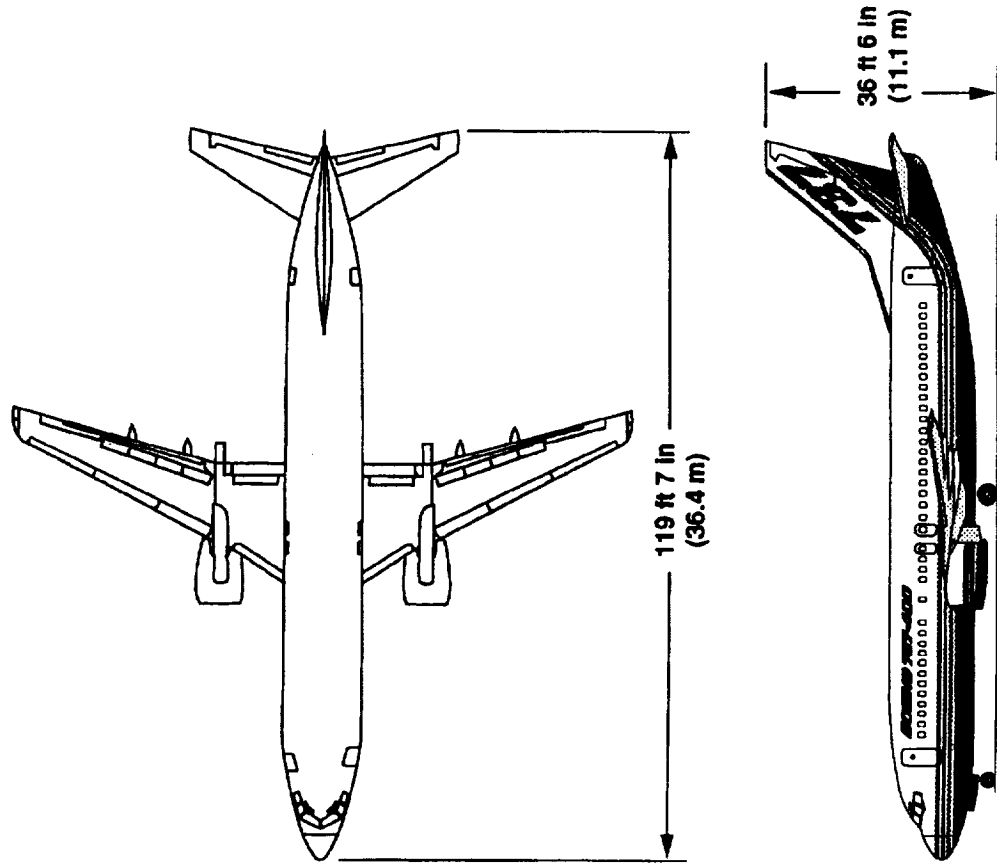

Appendix A-2

737-500 General Arrangement

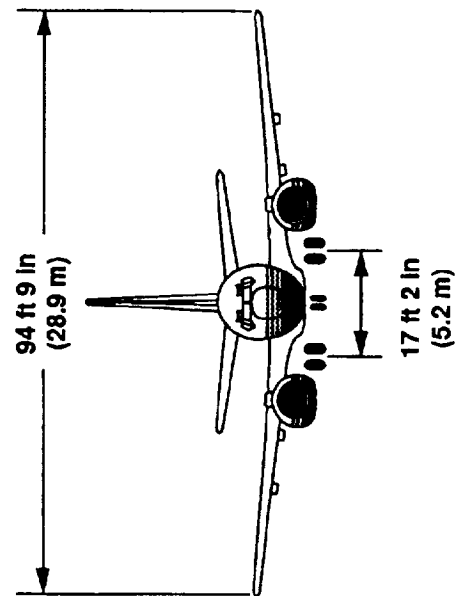
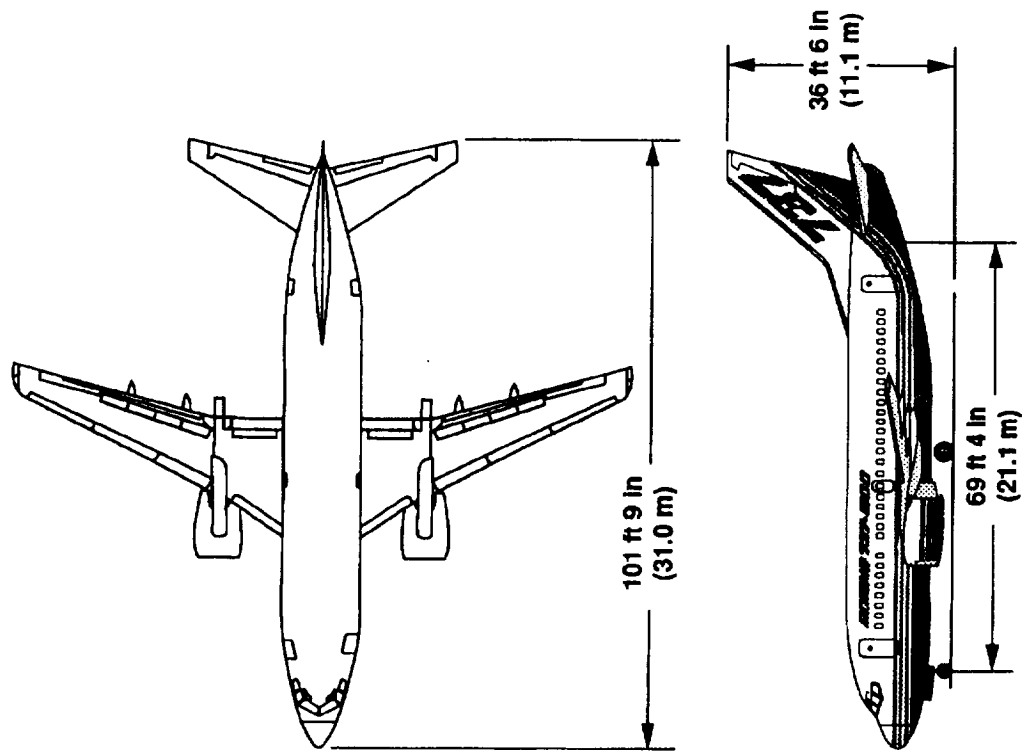

Appendix A-3

747-400 General Arrangement

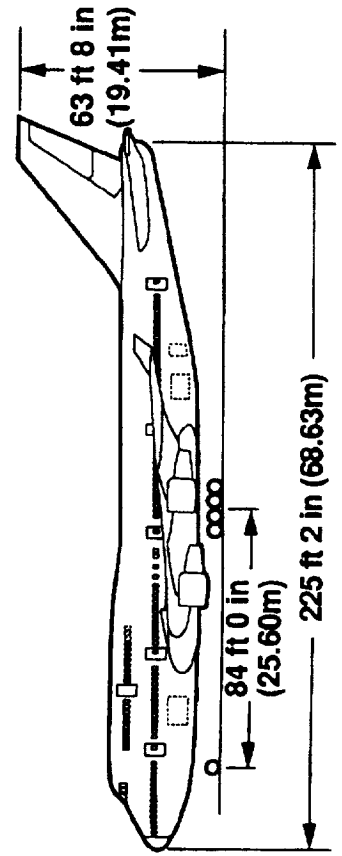
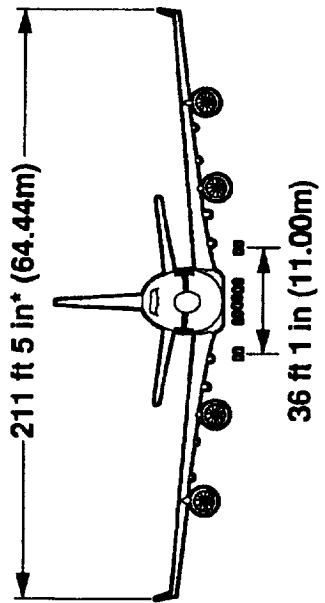
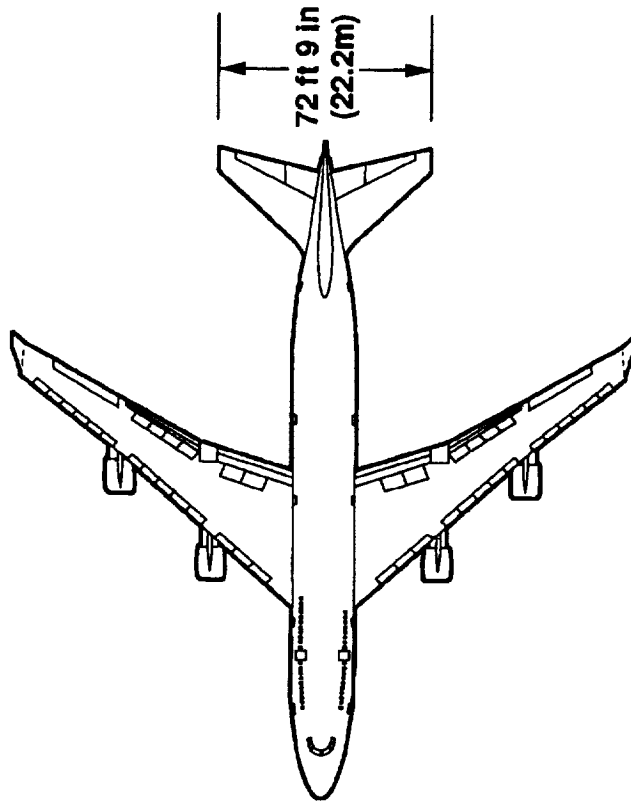

• 213 ft (64.92m) fully fueled

Appendix A-4

757-200 General Arrangement

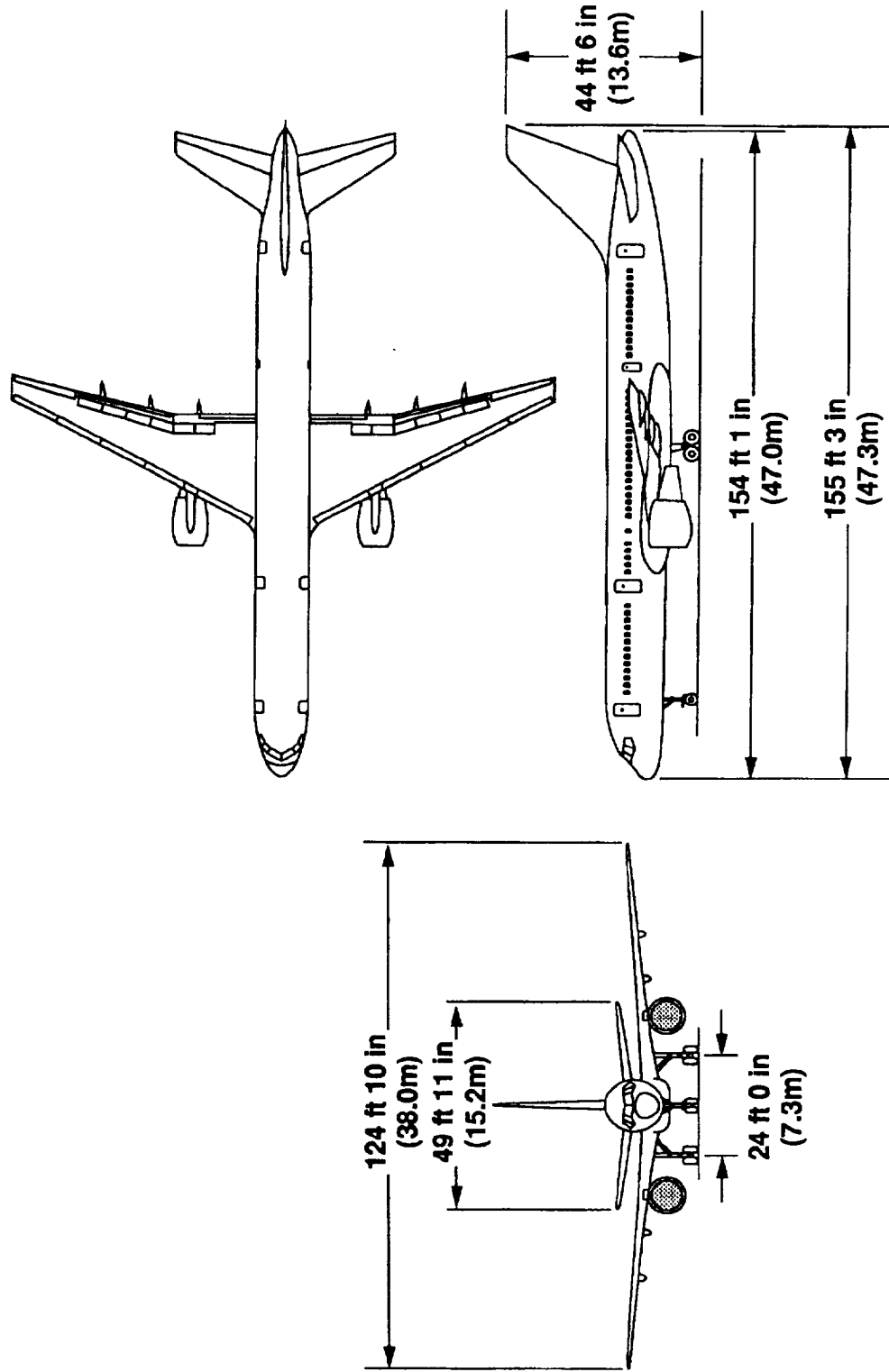

Appendix A-5

767-200 General Arrangement

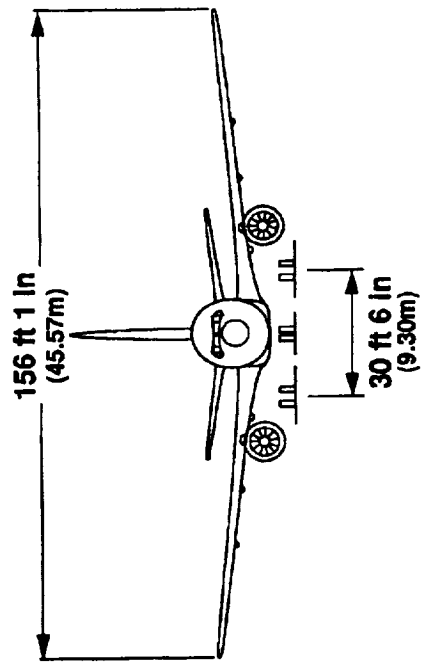
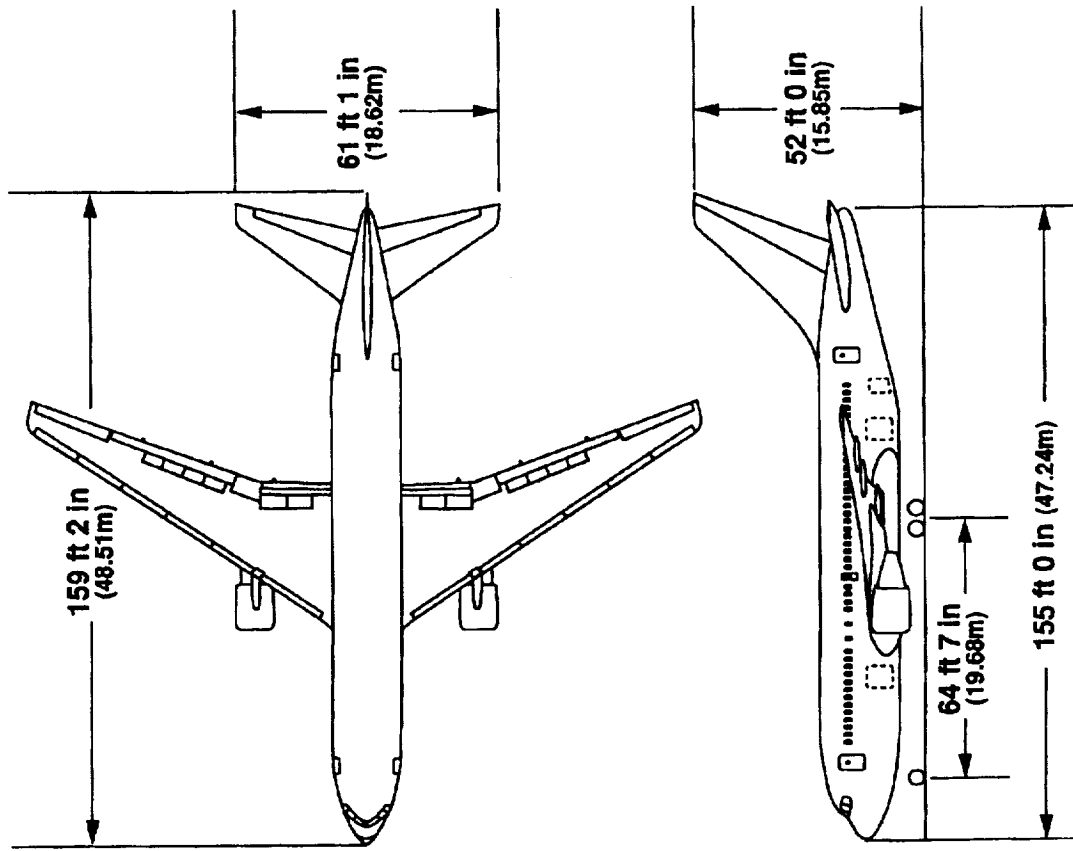

• 213 ft (64.92m) fully fueled

767-300 General Arrangement

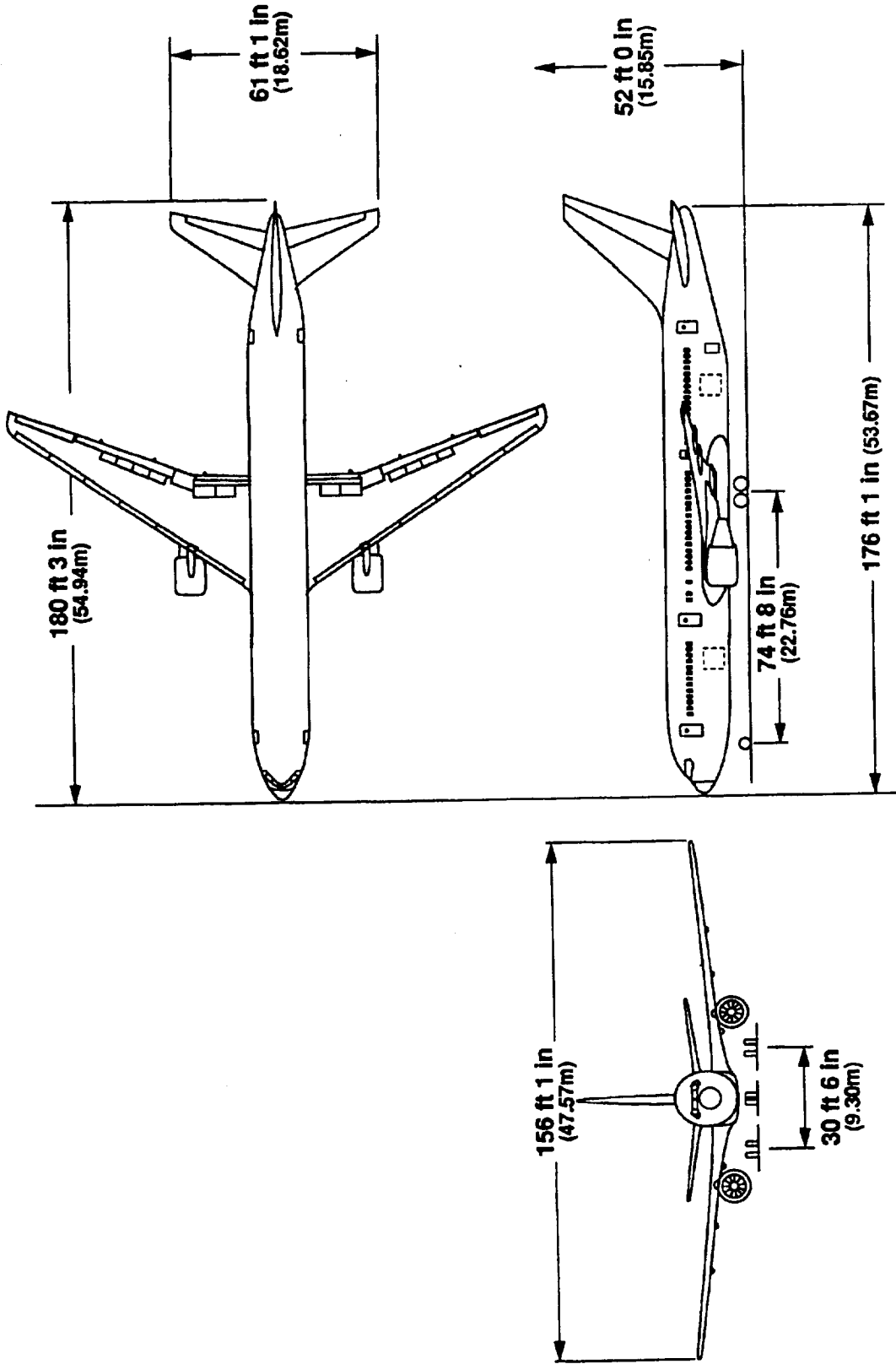

Appendix A-7

777-200 General Arrangement

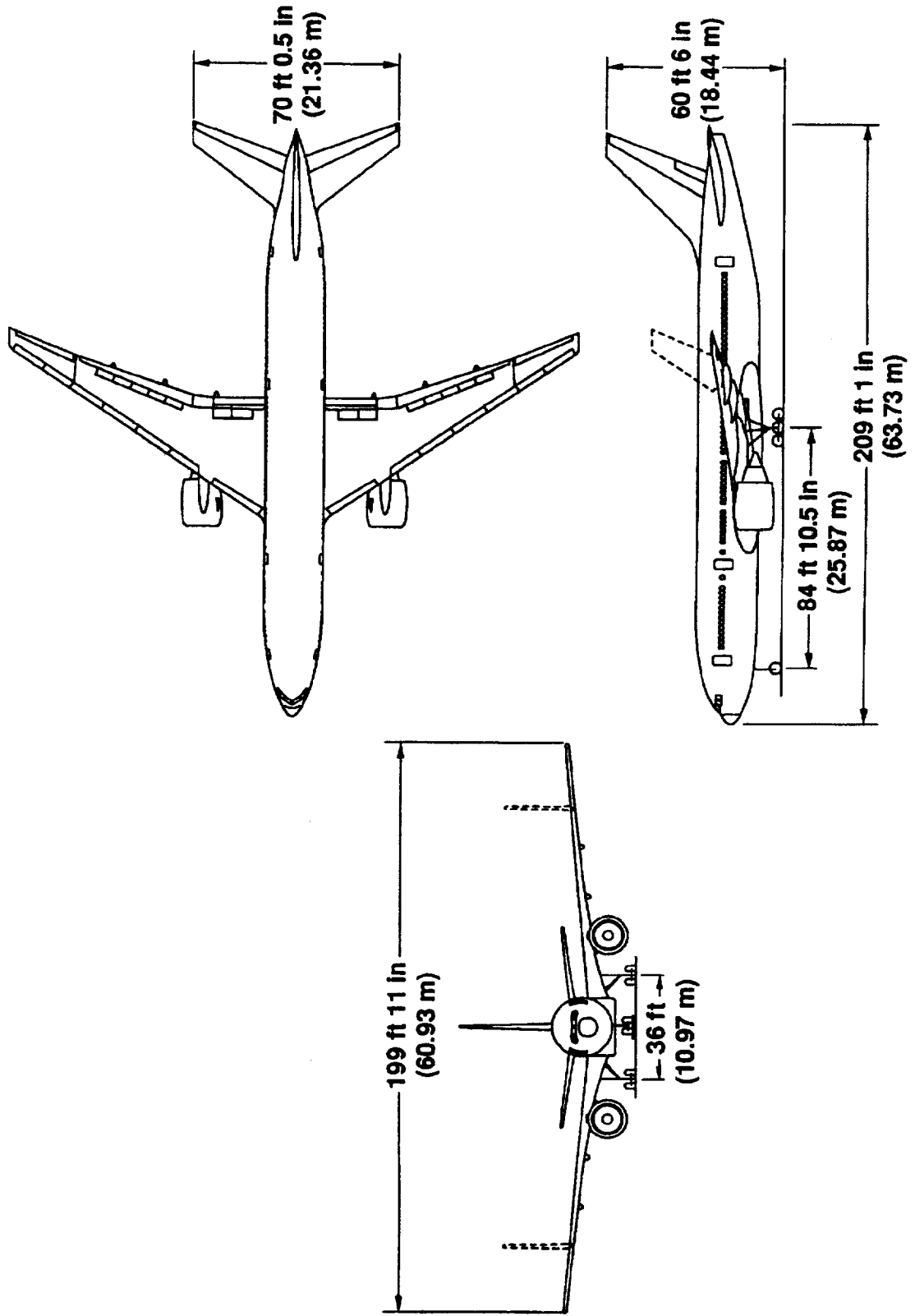

Appendix B
Standby Battery
Power Systems

Boeing 737 Standby Power

With a loss of all generators, the battery is the only source of electrical power. The following list identifies the busses and significant equipment that can be powered from the battery.

BATTERY BUS

Land gear lever latch/pressurization warning
A/C pack valves
A/C overheat
Ram air modulation control
AFDS MCP course 2 - DC
Passenger address amplifier
CSD control
Inverter control
Transfer bus indication
Battery bus volts indication
Captain's & F/O's interphone
APU & engine fire detection
Master warning & control
Standby rudder SOV
Fuel crossfeed valve
Engine hydraulic SOV
Clock display
Aural warning
Flight recorder
Anti-skid failure/parking brake
Anti-skid (outboard)
Landing gear - air/ground relay
Standby flood & compass light
Cockpit dome lights
Master dim, dimming & test
Master caution, (A/C, Fuel, Anti-ice)
Lavatory dome light
Position light (BATT)
Standby horizon
Manual oxy control, oxy indication
Passenger oxygen
APU control
APU fuel boost pump
Engine master caution
Engine 1 & wing anti-ice control
N1 tach indication, eng. 1, 2
EGT indication, eng. 1, 2

Thrust reverser control, eng. 1, 2
Start valves, eng. 1, 2
Static inverter
Fwd airstair cont. - standby

HOT BATTERY BUS

Battery overheat
Standby power manual control
Battery bus control
Hot battery bus indication
Standby power indication
External power control
Fire extinguishing bottles
Fuel SOV eng. 1, 2
Clock (timer)
Entry lights - dim
Aux. tank fueling valve

SWITCHED HOT BATTERY BUS

AFC A & B warning light
APU & engine generator control
Fuel SOV indication
IRS No. 1, 2
Digital analog adapter, No. 1

115V-AC STANDBY BUS

Inverter voltage indication
Standby bus indication
Fuel quantity
Pilots standby lights
Instrument transformer 1
Captain's ADI
Digital analog adapter, No. 2
IRS No. 1
Digital analog adapter/FMC-1
Engine 1, 2, right ignition

28V-DC STANDBY BUS

DC manual pressurization control
VHF comm. No. 1
DC standby bus indication
Instrument transformer
VOR/ILS (captain)
ADF No. 1
Stby altimeter/airspeed vibrator

Appendix B-1

PRECEDING PAGE BLANK NOT FILMED

Boeing 747-400 Standby Power

The following list identifies the busses and selected equipment receiving power from the respective bus. (This equipment can be powered by the battery)

APU BATTERY BUS

Auxiliary GCU 2
APU battery overheat protection
APU DC fuel pump
APU fire/bleed duct overheat loops A and B
BCU 2
Cabin interphone
EEC 1-4 fire/overheat detection loops A and B
Engine 1-4 speed sensors 1 and 2
Engine start air control
First officer's interphone
Left VHF
Left radio communication panel
Nacelle anti-ice 1-4
Observer's interphone
Passenger address systems 1-4
Primary landing gear display and control
Service interphone

APU HOT BATTERY BUS

APU duct overheat
APU fire warning horn
APU inlet door
APU primary control
BCU 1
IRS left, center and right DC
Left and right outflow valves

APU STANDBY BUS

(Captain's transfer bus unpowered)
Left FMC
Left PFD
Left ND

MAIN BATTERY BUS

Auxiliary GCU 1
APU alternate control
Autoflight warning
BCU 1
E/E cooling smoke override
Engine 1-4 fuel control valves
Engine 104 fuel crossfeed valve
Flight deck dome lights
Flight deck storm lights
Flight deck - captain's indicator lights
Generator drive disconnect 1-4
Hydraulics EDP supply 1-4
Left ILS antenna switch
Left and right manual cabin pressurization
Left aural warning
Left stabilizer trim/rudder ratio module (DC power)
Left stick shaker
Oxygen reset
Oxygen valve and indication
Parking brake
Primary trailing edge flap control DC
Standby altimeter vibrator
Standby attitude indicator
Upper yaw damper

Appendix B-2

Boeing 747-400 Standby Power (Continued)

MAIN HOT BATTERY BUS

ACARS DC
APU fire extinguisher
APU fuel shutoff valve
BCU 2
Emergency evacuation
Engine 1-4 fire extinguishers A and B
Engine 1-4 fuel shutoff valve
Fire switch unlock
Galley/utility ELCU control bus 1-4
GCU 1-4
IRS on battery
Lower cargo fire extinguisher
Main battery overheat protection

MAIN STANDBY BUS

Avionics and warning system status assembly
Flight control 1L and 2L AC
Left ADC
Left EFIS control
Left EIU
Left FMS-CDU
Left ILS
Left VOR
Primary trailing edge flap control AC
Standby ignition 1 and 2
Standby ignition engine 3 and 4
Standby instrument lights
Upper EICAS

CAPTAIN'S TRANSFER BUS

Avionics and warning systems status assembly
Center EIU
Left FMC
Left HF
Left ND
Left PFD

FIRST OFFICER'S TRANSFER BUS

Lower EICAS
FMCS autothrottle servo
Right ADC
Right EFIS control
Right EIU
Right FMC
Right FMS-CDU
Right HF
Right ND
Right PFD

Boeing 757 Standby Power

The main AC buses provide power for the EICAS system. If a single AC bus fails, EICAS automatically displays a listing of bus equipment that is inoperative. When both main AC buses fail, the battery is the only source of electrical power. The following list identifies the buses and significant equipment that can be powered from the battery.

HOT BATTERY BUS

- Fire extinguisher bottles
- Spar fuel valves
- APU fuel valve
- Clock time references
- IRS emergency power (L & C continuous, R for 5 minutes)
- RAT manual deployment
- Landing gear alternate extension
- Fueling system
- Parking brake valve

BATTERY BUS

- Passenger address system
- Interphone systems
- Engine, APU and cargo fire detection systems
- Fuel crossfeed valve
- Generator controls
- DC fuel pump
- Engine driven hydraulic pump shutoff valves
- Hydraulic PTU control
- Fuel quantity system
- Alternate equipment cooling
- RAT automatic deployment system
- Anti-skid for inboard wheels
- Landing gear air/ground system
- Forward cockpit dome lighting
- Passenger oxygen deployment system
- Standby engine indicating
- Engine start controls
- Engine fuel control valves
- Engine anti-ice
- Right pack valve
- Right engine T/R control
- Wing anti-ice

STANDBY DC BUS

- Left aural warnign system
- Manual cabin altitude pressure control
- Left yaw damper*
- Left VHF comm. system
- Standby attitude indicator
- Stab trim shutoff valves
- Left stick shaker
- Rudder trim
- Captain's clock indications
- Left pack valve
- Left engine T/R control
- Bleed air isolation valve*

STANDBY AC BUS

- Cabin altitude/differential pressure indications
- Left yaw damper*
- Three spoiler pairs
- Left navigation system (VOR, Air Data Computer & RDMI)
- Right ADF
- Left ADF**
- Center ILS system
- Standby instrument panel lights
- Engine ignition system
- Wheelwell fire detection
- Main panel flood lights
- Bleed air isolation valve*

* Requires both ac and dc power to operate

** As installed

Appendix B-4

Boeing 767 Standby Power

The main AC buses provide power for the EICAS system. If a single AC bus fails, EICAS automatically displays a listing of bus equipment that is inoperative. When both main AC buses fail and the Hydraulic Driven Generator fails, the battery is the only source of electrical power. The following list identifies the buses and significant equipment that can be powered from the battery.

HOT BATTERY BUS

Fire extinguisher bottles
Spar fuel valves
APU fuel valve
Clock time references
IRS emergency power (L & C continuous, R for 5 minutes)
RAT manual deployment
Fueling system
Parking brake valve

BATTERY BUS

Landing gear alternate extension
Passenger address system
Interphone systems
Engine, APU and cargo fire detection systems
Fuel crossfeed valve
Generator controls
DC fuel pump
Engine driven hydraulic pump shutoff valves
Air driven hydraulic pump control
RAT automatic deployment system
Equipment cooling override system
Anti-skid for inboard wheels
Landing gear air/ground system
Fuel quantity system
Passenger oxygen deployment system
Standby engine indication
Engine start controls
Engine fuel control valves
Right engine R-R control
Right pack valve
Wing anti-ice
Right engine anti-ice
Alternate stabilizer trim

STANDBY DC BUS

Engine fuel heat control
Manual cabin altitude pressure control
Aisle stand flood light
Left yaw damper*
Three spoiler pairs*
Left VHF comm. system
Left stick shaker
Standby attitude indicator
Stab trim shutoff valves
Left aural warning speaker
Left engine T/R control
Left pack valve
Left engine anti-ice
Captains clock indications
Rudder trim

STANDBY AC BUS

Engine ignition system
Cabin altitude/differential pressure indications
Left yaw damper*
Three spoiler pairs*
Main panel flood lights
Left navigation system (VOR, Air Data Computer & RDML)
Right ADF
Center ILS system
Wheelwell fire detection
Duct leak detection
Equipment cooling standby mode
Standby instrument panel lights

* Requires both ac and dc power to operate

Appendix B-5

PAGE _____ INTENTIONALLY BLANK

Appendix C
Return to Service
Cost Breakdowns

PRECEDING PAGE BLANK NOT FRAMED

PAGE _____ INTENTIONALLY BLANK

Chapter 21 – Air-Conditioning

ATA Code	Subject	Time (mhr)	Labor Cost(s)	Material Cost(s)	Total Cost(s)
21-00	Air-conditioning – general				
21-20	Distribution	5	250	—	250
21-21	Main manifold	5	250	—	250
21-22	Flight deck				
21-23	Passenger cabin	8	400	—	400
21-24	Individual air distribution	93	4,650	—	4,650
21-25	Cabin air recirculation	8	400	—	400
21-26	Ventilation	10	500	—	500
21-31	Press control				
21-32	Press relief valve				
21-33	Press indication/warning				
21-43	Forward cargo heat				
21-44	Aft cargo heat				
21-45	Supplement heat				
21-51	Air-conditioning pack				
21-52	Pack temperature				
21-53	Ram air				
21-58	Equipment cooling	14	700	—	700
21-61	Temperature control				
21-64	Valve position				
21-65	Cabin temperature				

PRECEDING PAGE BLANK NOT FILMED

Appendix C-1

Chapter 23 – Communications

ATA Code	Subject	Time (mhr)	Labor Cost(s)	Material Cost(s)	Total Cost(s)
23-00	Communication – general	20	1,000	—	1,000
23-10	Speech				
23-12	Very high frequency (VHF) system*				
23-21	Selective calling (SELCAL)*				
23-22	ARINC communications addressing and reporting system (ACARS)*				
23-31	Passenger address (PA) system	10	500	—	500
23-32	Passenger entertainment	1180	59,000	80,900	139,900
23-41	Service interphone				
23-42	Cabin interphone	5	250	—	250
23-43	Ground crew call				
23-51	Flight interphone	5	250	—	250
23-61	Static discharge				
23-71	Voice recorder	6	300	—	300
23-91	Airfone system	4	200	—	200

* See main equipment center information

Chapter 24 – Electrical Power

ATA Code	Subject	Time (mhr)	Labor Cost(s)	Material Cost(s)	Total Cost(s)
24-00	Electrical power				
24-10	Generator drive				
24-21	Alternating current (ac)				
24-22	AC control				
24-23	Fault sensing				
24-27	AC annunciation				
24-28	AC meters				
24-31	Batteries*				
24-32	Transformer*				
24-33	Standby power*				
24-34	Direct current (dc) meters				
24-41	External power*				
24-51	115V-ac distribution*				
24-53	28V-ac distribution*				
24-54	28V-dc distribution*				

* See main equipment center information

Chapter 25 – Equipment/Furnishings

ATA Code	Subject	Time (mhr)	Labor Cost(s)	Material Cost(s)	Total Cost(s)
25-21-01 -02	Sidewall panel	224	11,200	—	11,200
25-21-04	Kickstrip (Sw)	118	5,900	1,400	7,300
25-21-05	Insulation (Sw)	153	7,650	115,400	123,050
25-21-53	Literature pocket				
25-22-02	Ceiling	248	12,400	—	12,400
25-22-03	Insulation (ceiling)	459	22,950	20,750	43,700
25-23-01	Passenger service unit (PSU)	196	9,800	—	9,800
25-24	Divider/closet	81	4,050	—	4,050
25-25	Seat assembly	1382	69,100	36,320	105,420
25-27	Floor covering	72	3,600	4,470	8,070
25-28	Overhead bins	236	11,800	—	11,800
25-29	Cabin power				
25-31	Galley	172	8,600	—	8,600
25-41	Lavatory	156	7,800	—	7,800
25-50	Insulation (CG)	306	15,300	136,100	151,400
25-51	Electrical-cargo compartment				
25-60	Emergency equipment				
25-61	Rope-safety				
25-62	Life vest	47	2,350		2,350
25-63	Miscellaneous emergency				
25-64	Axe				
25-65	Escape slide	12	600	—	600
25-66	Escape slide	12	600	—	600
25-70	Electrical equipment center*				
25-71	Electrical equipment center*				

* See main equipment center information

Appendix C-4

Chapter 33 – Lights

ATA Code	Subject	Time (mhr)	Labor Cost(s)	Material Cost(s)	Total Cost(s)
33-10	Flight compartment lights				
33-11	Flight compartment illumination				
33-13	Integral panel				
33-14	Flight compartment miscellaneous				
33-16	Master dim/test				
33-20	Cabin lights				
33-21	Cabin illumination	248	12,400	74,400	86,800
33-22	Passenger loading	6	300	1,800	2,100
33-23	Passenger reading	62	3,100	12,400	15,500
33-24	Passenger signs	15	750	—	750
33-25	Passenger/lavatory call	15	750	—	750
33-26	Lavatory lights	5	250	1,500	1,750
33-27	Galley lights	5	150	900	1,050
33-31	Service lights				
33-37	Cargo lights				
33-41	Wing lights				
33-42	Landing/taxi lights				
33-43	Position lights				
33-44	Anti-collision				
33-51-01	Exit signs	6	300	1,800	2,100
33-51-03	Floor path lights	278	13,900	4,700	18,600
33-51-05	Aisle lights	62	3,100	—	3,100
33-51-06	Slide lights	6	300	600	900
33-51-07	Battery pack	2	100	—	100
33-51-08	Control panel emergency	6	300	—	300
33-51-09	Flight deck emergency				

Appendix C-5

Chapter 35 – Oxygen

ATA Code	Subject	Time (mhr)	Labor Cost(s)	Material Cost(s)	Total Cost(s)
35-11	Crew oxygen				
35-21	Passenger oxygen (electric door unlatch)	93	4,650	—	4,650
35-31	Portable oxygen				

Chapter 51 – Structures

ATA Code	Subject	Time (mhr)	Labor Cost(s)	Material Cost(s)	Total Cost(s)
51-21	Structure finishes	48	2,400	—	2,400
51-24	Corrosion protection	36	1,800	700	2,500
51-31	Seals	32	1,600	—	1,600
51-41	Airframe drain	16	800	—	800
51-51	Rub pads				
51-61	Lighting protection				

Chapter 53 – Fuselage

ATA Code	Subject	Time (mhr)	Labor Cost(s)	Material Cost(s)	Total Cost(s)
53-01	Cabin floor	426	21,300	90	21,390
53-12	Nose radome				
53-36	Forward fairing				
53-66	Aft fairing				
53-86	Stab fairing				
53-87	Cargo compartment				
53-88	Cargo panels	246	12,300	—	12,300

Appendix C-6

Main Equipment Center – E1 Rack

M192, Window HEAT-R
T102, TRU-R
T101, TRU-L
M191, Window HEAT-L
6.5 mhr x 4 units = 26 mhr
26 mhr x \$50/mhr = \$1,300

Main Equipment Center – E2 Rack

M00139, FCC-L
M00156, ILS-L
M00148, EFIS SYM-GEN-L
M00134, FMC-L
M00100, ADC-L
M00101, ADC-R
M00150, EFIS SYM-GEN-R
M00135, FMC-R
M00158, ILS-R
M00141, FCC-R
M00157, ILS-C
M00917, ILS-PROC-UNIT
M00147,
M00140, FCC-C
M00149, EFIS SYM-GEN-C
M00183, TMC
M00161, IRU-R
M00160, IRU-C
M00159, IRU-L
6.5 mhr x 19 units = 123.5 mhr
123.5 mhr x \$50/mhr = \$6,175

Appendix C-7

Main Equipment Center – E3 Rack

K574,	Trim Limit SEL-L		
M536,	Power Supply		
M530,	Spoiler Control		
M528,	Rudder Ratio		
M531,	Spoiler Control		
M524,	Stab trim aileron-L		
M522,	Left yaw damper		
M532,	Spoiler control		
M537,	Power supply		
M168,	MCDP		
M124,	DME-R		
M10142,	ATC Trans-R		
M10141,	ATC Trans-L		
M123,	DME-L		
M9124,	TCAS		
M138,	DFDAU		
M162,	Prox SW Elex Unit		
M121,	Fuel quantity		
6.5 mhr x 18 units	=	117 mhr	
117 mhr x \$50/mhr	=	\$5,850	

Appendix C-8

Main Equipment Center – E4 Rack

M00539,	Power supply		
M00535,	Spoiler control		
M00523,	Yaw damper-R		
M00575,	Relay trim-R		
M00534,	Spoiler Control		
M00529,	Rudder ratio-R		
M00533,	Spoiler control		
M00538,	Power supply		
M10182,	EICAS-R		
P69,	EICAS replay pnl		
M10181,	EICAS-L		
M00132,	Engine V/B		
M00916,	Pack flow proc		
M00188,	VHF-L		
M00180,	SELCAL decoder		
M00189,	VHF-R		
M00108,	Audio ACC unit		
M00177,	PA amp		
ACARS OAT			
VHF-C			
VHF-COM XCUR-L			
M9117,	Main mux		
M9116,	Audio tape reproducer		
6.5 mhr x 25 units		=	162.5 mhr
162.5 mhr x \$50/mhr		=	\$8,125

Appendix C-9

Main Equipment Center – E5 Rack

M00143, GCU APU
M00202, XMTR RAD ALTM REC-L
M10331, Flap/Slat ELEX Unit 1
M00144, GCU-L
M00118, Cabin Press Control Auto 1
M01552, PDIU-L
M10610, ECC MON-L
M00203, XMTR RAD ALTM REC-R
M10611, ECC MON-R
M10553, PDIU-R
M00119, Cabin Press Control Auto 2
M10333, Flap/Slat ELEX Unit 3
M00146, GRU-R
M00102, Anti-Skid Autobrake
M00204, XMTR RAD ALTM REC-C
M10332, Flap/Slat ELEX Unit 2
M00116, BPCU
M00115, Brk Temp Mon

6.5 mhr x 18 units = 117 mhr

117 mhr x \$50/mhr = \$5,850

Main Equipment Center – E6 Rack

M00187,	VOR MB-R		
M00186,	VOR MB-L		
M00215,	ADF-L		
M216,	ADF-R		
M00207,	APU Batt Chgr		
M00127,	Pack Temp-R		
M00122,	Hyd Qty		
M00115,	Brake Temp		
M00102,	Anti-Skid		
M00206,	APU Control		
M00195,	Zont Cont		
M00126,	Pack Temp-L		
M10389,	Stby Pack Temp		
M10251,	Shunt		
M00208,	APU Batt		
6.5 mhr x 15 units		=	97.5 mhr
97.5 mhr x \$50/mhr		=	\$4,875

Main Equipment Center – Panels

P31, P32, P33, P34, P36, P37, P50, P51, P54, P70			
25 mhr/panel includes repair and checkout			
25 mhr x 10 panels		=	250 mhr
250 mhr x \$50/mhr		=	\$12,500

Appendix C-11

	<u>A/C DISTRIBUTION</u>	
<u>ATA 21-20</u>	- Labor	<u>5 mhr</u>
	- Labor Cost (5 x \$50)	- \$250
	<u>MAIN MANIFOLD</u>	
<u>ATA 21-21</u>	- Labor	<u>5 mhr</u>
	- Labor Cost (5 x \$50)	- \$250
	<u>PASS CABIN</u>	
<u>ATA 21-23</u>	- Labor (6+2)	<u>8 mhr</u>
	- Labor Cost (8 x \$50)	- \$400
	<u>INDIV AIR DISTR</u>	
<u>ATA 21-24</u>	- Labor (0.5 mhr x 187)	<u>93 mhr</u>
	- Labor Cost (93 x \$50)	- \$4650
	<u>CABIN AIR RECIR</u>	
<u>ATA 21-25</u>	- Labor	<u>8 mhr</u>
	- Labor Cost (8 x \$50)	- \$400
	<u>VENTILATION</u>	
<u>ATA 21-26</u>	- Labor	<u>10 mhr</u>
	- Labor Cost (10 x \$50)	- \$500
	<u>EQUIP COOLING</u>	
<u>ATA 21-58</u>	- Labor (2 x 7 mhr)	<u>14 mhr</u>
	- Labor Cost (14 x \$50)	- \$700

Appendix C-12

COMMUNICATION GENERAL

ATA 23-00

- Labor (2 x 10 mhr) 20 mhr
- Labor Cost (20 x \$50) - \$1000

PA SYSTEM

ATA 23-31

- Labor (2 x 5 units) 10 mhr
- Labor Cost (10 x \$50) - \$500

PASS ENTERTAIN SYS

ATA 23-32

- Labor (0.50 x 2360) 1180 mhr
- 50% of
EO 6-57746-3 - Labor Cost (1180 x \$50) - \$59,000
- Material Cost (0.50 x 161,800) - \$80,900

CABIN INTERPHONE

ATA 23-42

- Labor (1 x 5 units) 5 mhr
- Labor Cost (5 x \$50) - \$250

FLT INTERPHONE

ATA 23-51

- Labor (1 x 5 units) 5 mhr
- Labor Cost (5 x \$50) - \$250

VOICE RECORDER

ATA 23-71

- Labor 6 mhr
- Labor Cost (6 x \$50) - \$300

AIRPHONE SYS

ATA 23-91

- Labor 4 mhr
- Labor Cost (4 x \$50) - \$200

ATA 25-21-01

SIDEWALLS (CABIN)

	-	Panel Cost		
(Remove & Install)	-	Labor (6x8) + (6x8+4x16)		
		48 mhr + 112 mhr	-	<u>160 mhr</u>
	-	Labor Cost (160x\$50)	-	<u>\$8,000</u>
(Repair)	-	Labor (4x16)	-	<u>64 mhr</u>
	-	Labor Cost (64x\$50)	-	<u>\$3,200</u>

ATA 25-21-04

SIDEWALL KICKSTRIP

	-	Panel Cost		
	-	Carpet Cost 31x \$45	-	<u>\$1,400</u>
(Remove & Install)	-	Labor (Panel)(2x8)+(2x8+6)	-	38 mhr
		(Carpet) (2x4)+(4x8)	-	40 mhr
				<u>78 mhr</u>
	-	Labor Cost (78x\$50)	-	<u>\$3,900</u>
(Repair)	-	Labor (4x10)	-	<u>40 mhr</u>
	-	Labor Cost (40x\$50)	-	<u>\$2,000</u>

Appendix C-14

ATA 25-21-05

INSULATION (SIDEWALL)

	-	Insulation Blanket Cost	
(411N4107-7)		166 x \$215 = \$35,700	
(<u>\$115,400</u>
(411N4101-87)		332 x \$240 = \$79,700	
(Remove & Install)	-	Labor (8 x 8) + (8 x 8 + 25)	
		64 + 89 = <u>153 mhr</u>	
	-	Labor Cost (153x\$50)	<u>\$ 7,650</u>
(Repair)	-	Labor (Not Applicable)	
(411N4101-7)		\$215/EA	
(411N4101-9)		\$215/EA PER PURCHASING DEPT.	

ATA 25-22-02

CEILING PANELS

	-	Panel Cost	
(Remove & Install)	-	Labor (8x8+4) + (8x8+4+16)	
		69 mhr + 84 mhr	<u>152 mhr</u>
	-	Labor Cost (152x\$50)	<u>\$ 7,600</u>
(Repair)	-	Labor (6x16)	<u>96 mhr</u>
	-	Labor Cost (96x\$50)	<u>\$ 4,800</u>

Appendix C-15

ATA 25-22-03

INSULATION (CEILING)

	-	Insulation Blanket Cost		
(411N4301-2/-3)		83 x (240+230+260+270)		
(411N4421-2/-6)		(4)	-	<u>\$20.750</u>
(Remove & Install)	-	Labor (8x8x3)+(8x8x3+75)		
		192 + 267	=	<u>459 mhr</u>
	-	Labor Cost (459x\$50)	-	<u>\$22.950</u>
(Repair)	-	Labor (Not Applicable)		
411N4301-2		\$240		
411N4301-3		\$230		
411N4421-2		\$260		
411N4421-6		\$270		
			PER PURCHASING DEPT.	

ATA 25-23

PASSENGER SERVICE UNITS

	-	PSU Component Cost		
(Remove & Install)	-	Labor 4x8 + 4x8+8		
		32 + 40	=	<u>72 mhr</u>
	-	Labor Cost (72x\$50)	-	<u>\$ 3.600</u>
(Repair)	-	Labor (2x62 units)	=	<u>124 mhr</u>
	-	Labor Cost (124 x \$50)	-	<u>\$6.200</u>

ATA 25-24

DIVIDER/CLOSET

(Remove & Install)	-	Labor (4x4) + (4x4+3) +		
		(2x2) + (2x2+2)=		<u>61 mhr</u>
	-	Labor Cost (61 x \$50)	-	<u>\$3.050</u>
(Clean/Dry)	-	Labor (4x4) + (2x2)	=	<u>20 mhr</u>
	-	Labor Cost (20 x \$50)	-	<u>\$1.000</u>

Appendix C-16

ATA 25-25SEAT ASSEMBLY

	-	Seat Cover (Replacement)		
	-	P/N 829948, 829949, 817755, 829625		
(16 x 95.21 + 171 x 82.26)	-	Cover Cost	-	<u>\$15,590</u>
(Remove & Install)	-	Labor (8 + 16) = 24 mhr		
	-	Labor Cost (24x\$50)	-	<u>\$ 1,200</u>
(Remove & Install)	-	Seats - Labor 25 + 24 = 49 mhr		
	-	Labor Cost (49x\$50)	-	<u>\$ 2,450</u>
(19134001, 19133005 20183002, 20132001)	-	Seat Cushions		
	-	Material 16 (41.30 + 55.55) + 171 (63 + 49.17) 1549.6 + 19,181	-	<u>\$20,730</u>
(Remove & Install)	-	Labor 187 (0.5mhr + 0.5 mhr) = 187 mhr		
	-	Labor Cost (187x\$50)	-	<u>\$ 9,350</u>
	-	Passenger Service System		
(Remove, Install)	-	Labor 187 x 2 mhr = 374 mhr		
	-	Labor Cost (374x\$50)	-	<u>\$18,700</u>
(Repair/Checkout)	-	Mech. Seat Operation		
	-	In-seat Passenger Service System Components Repair		
	-	Functional Test of Passenger Service System		
	-	Labor 187 x 4 mhr = 748 mhr		
	-	Labor Cost (748 x \$50)	-	<u>\$37,400</u>

ATA 25-27FLOOR COVERINGS

	-	Carpet (Replacement)		
	-	P/N 25-1994-XXXX		
(Mat'l & Labor)	-	Panel Cost		<u>\$ 4,470</u>
(Remove & Install)	-	Labor (24 + 48 mhr) = 72 mhr		
	-	Labor Cost (72x\$50) =		<u>\$ 3,600</u>

Appendix C-17

ATA 25-28

OVERHEAD STORAGE UNIT

	-	Bin (Door/Housing) Cost		
(Remove & Install)	-	Labor (4x16)+(4x16+12) 64 + 76	-	<u>140 mhr</u>
	-	Labor Cost (140x\$50)	=	<u>\$ 7.000</u>
(Repair)	-	Labor (6x16)	-	<u>96 mhr</u>
	-	Labor Cost (96x\$50)	-	<u>\$ 4.800</u>

ATA 25-31

GALLEY

(Remove & Install)	-	Labor (FWD) (4x2x3)+(4x2x3+8) 24 + 32	=	56 mhr
	-	Labor (REAR)(3x12)+(3x12+20) 36 + 56	=	92 mhr
				<u>148 mhr</u>
	-	Labor Cost (148x\$50)	=	<u>\$ 7.400</u>
(Repair)	-	Labor (4x6)	-	<u>24 mhr</u>
	-	Labor Cost (24 x \$50)	-	<u>\$ 1.200</u>

ATA 25-41

LAVATORIES

(Remove & Install)	-	Labor (FWD & MID) (2x6x2)+(24+8) 24 + 32	=	56 mhr
	-	Labor (REAR) (2x8x2)+(2x8x2+12) 32 + 44	=	76 mhr
				<u>132 mhr</u>
	-	Labor Cost (132x\$50)	=	<u>\$ 6.600</u>
(Repair)	-	Labor (4x6)	-	<u>24 mhr</u>
	-	Labor Cost (24 x \$50)	-	<u>\$ 1.200</u>

Appendix C-18

<u>ATA 25-50</u>	<u>INSULATION (CC)</u>		
(411N4851-82/85/437)	- Insulation Blanket Cost		
	498 x $\frac{(260+260)}{3}$ 300)		- <u>\$136,100</u>
(Remove & Install)	- Labor (8x16) + (8x16+50)		
	128 + 178 =	<u>306 mhr</u>	
	- Labor Cost (306 x \$50)		- <u>\$ 15,300</u>
 <u>ATA 25-62</u>	 <u>LIFE VEST</u>		
	- Labor (0.25 mhr x 187) =	<u>47 mhr</u>	
	- Labor Cost (47 x \$50)		- <u>\$ 2,350</u>
 <u>ATA 25-65</u>	 <u>ESCAPE SLIDE</u>		
	- Labor (4 mhr x 3) =	<u>12 mhr</u>	
	- Labor Cost (12 x \$50)		- <u>\$ 600</u>
 <u>ATA 25-66</u>	 <u>ESCAPE SLIDE</u>		
	- Labor (4 mhr x 3) =	<u>12 mhr</u>	
	- Labor Cost (12 x \$50)		- <u>\$ 600</u>
 <u>ATA 33-21</u>	 <u>CABIN ILLUM</u>		
(Remove & Install)	- Labor		
	1 mhr x (47x4+15x4) =	<u>248 mhr</u>	
	- Labor Cost (248 x \$50)		- <u>\$ 12,400</u>
	- Material Cost (248 units x \$300)		- <u>\$ 74,400</u>
 <u>ATA 33-22</u>	 <u>PASS LOADING</u>		
(Remove & Install)	- Labor (1 mhr x 6) =	<u>6 mhr</u>	
	- Labor Cost (6 x \$50)		- <u>\$ 300</u>
	- Material Cost (6 x \$300)		- <u>\$ 1,800</u>

Appendix C-19

ATA 33-23

PASS READING

(Remove & Install) - Labor (1 mhr x 187/3) - 62 mhr
- Labor Cost (62 x \$50) - \$ 3,100
- Material Cost (62 x \$200) - \$12,400

ATA 33-24

PASS SIGNS

(Inspect) - Labor (0.25 mhr x 62) - 15 mhr
- Labor Cost (15 x \$50) - \$ 750

ATA 33-25

PASS/LAV CALL

(Inspect) - Labor (0.25 mhr x 62) = 15 mhr
- Labor Cost (15 x \$50) - \$ 750

ATA 33-26

LAV LIGHTS

(Remove & Install) - Labor (1 mhr x 5) - 5 mhr
- Labor Cost (5 x \$50) - \$ 250
- Material Cost (5 x \$300) - \$ 1,500

ATA 33-27

GALLEY LIGHTS

(Remove & Install) - Labor (1 mhr x 3) - 3 mhr
- Labor Cost (3 x \$50) - \$ 150
- Material Cost (3 x \$300) - \$ 900

ATA 33-51-01

EXIT SIGNS

(Remove & Install) - Labor (1 mhr x 6) - 6 mhr
- Labor Cost (6 x \$50) - \$ 300
- Material Cost (6 x \$300) - \$ 1,800

Appendix C-20

<u>ATA 33-51-03</u>	<u>FLOOR PATH LIGHTS</u>		
(EO 6-53336-3)	- Labor	- <u>278 mhr</u>	
	- Labor Cost (278 x \$50)		- <u>\$13,900</u>
	- Material Cost		- <u>\$ 4,700</u>
<u>ATA 33-51-05</u>	<u>AISLE LIGHTS</u>		
(Inspect)	- Labor (1 mhr x 187/3)	= <u>62 mhr</u>	
	- Labor Cost (62 x \$50)		= <u>\$ 3,100</u>
<u>ATA 33-51-06</u>	<u>SLIDE LIGHTS</u>		
(Remove & Install)	- Labor (1 mhr x 6)	= <u>6 mhr</u>	
	- Labor Cost (6 mhr x \$50)		= <u>\$ 300</u>
	- Material Cost (6 x \$500)		= <u>\$ 600</u>
<u>ATA 33-51-07</u>	<u>BATTERY PACK</u>		
(Inspect)	- Labor	- <u>2 mhr</u>	
	- Labor Cost (2 x \$50)		- <u>\$ 100</u>
<u>ATA 33-51-08</u>	<u>CONTROL PANEL EMRG</u>		
(Inspect)	- Labor	- <u>6 mhr</u>	
	- Labor Cost (6 x \$50)		- <u>\$ 300</u>
<u>ATA 35-21</u>	<u>PASS OXYGEN DOOR</u>		
(Inspect)	- Labor (0.5 mhr x \$187)	= <u>93 mhr</u>	
	- Labor Cost (93 x \$50)		= <u>\$4,650</u>

Appendix C-21

ATA 51-21

STRUCTURE FINISHES

(Inspect/Water Removal) - Labor (6x8) - 48 mhr
- Labor Cost (48 x \$50) - \$ 2,400

ATA 51-24

CORROSION PROTECTION

(Application) - Labor (6x6) - 36 mhr
- Labor Cost (36 x \$50) - \$ 1,800
- Material Cost (2x35x10) = \$ 700

ATA 51-31

SEALS

(Inspect) - Labor (4x8) - 32 mhr
- Labor Cost (32 x \$50) - \$ 1,600

ATA 51-41

A/C DRAINS

(Inspect) - Labor (2x8) - 16 mhr
- Labor Cost (16 x \$50) - \$ 800

Appendix C-22

ATA 53-01

FLOOR PANELS (CABIN)

	-	Panel Cost		
	-	Sealer Cost 18x \$5	-	<u>\$ 90</u>
(Remove & Install)	-	Wingbox Rest Labor (4x2) + (12x16) + (4x2+2) + (12x16+24) 8 + 192 + 10 + 216 = <u>426 mhr</u>		
	-	Labor Cost (426x\$50)	-	<u>\$21,300</u>

ATA 53-88

SIDEWALL/FLOOR PANELS (CARGO)

	-	Panel (Floor) Cost		
	-	Panel (Side) Cost		
(Remove & Install)	-	Labor - Floor (4x12) + (4x12+10) = 106 mhr Sidewall (4x16) + (4x16+12) = 140 mhr TOTAL <u>246 mhr</u>		
	-	Labor Cost (246x\$50)	-	<u>\$12,300</u>

MAIN EQUIPMENT CENTER

E1, E2, E3, E4, E5, E6 RACKS

(Remove/Install)	-	Labor	=	0.5 mhr
(Unit Checkout)	-	Labor	=	3 mhr
(Sys Checkout)	-	Labor	=	1 mhr
(Repair)	-	Labor	=	2 mhr
		TOTAL	-	<u>6.5 mhr</u>

Appendix C-23

PAGE _____ INTENTIONALLY BLANK

Appendix D

Configuration Memo

PRECEDING PAGE(S) NOT FILMED

PAGE _____ INTENTIONALLY BLANK

Subject: Configuration Definition of 757-200 Model 761-650

Configuration Description

The Model 761-650 is a modified four door 757-200 (Standard Option 1.33a) passenger airplane configured to provide a passenger cabin water spray system (see reference (b)). The nozzle and connecting feedline configuration will be a customer variable installation. The nozzle arrangement used in this study is for a British Airways interior arrangement LOPS-5724-1656 D (see Figure 6).

The major characteristics of the Model 761-650 (see Figure 1) include:

- Two non-metallic water reservoir tanks (similar to existing potable water tanks) of approximately 40 gallons each, in body section 43 and 46, respectively.
- Water tank maintenance panel adjacent each water tank (see Figure 4 and 5).
- 3000 psi nitrogen bottle with squib activated pneumatic valve, adjacent each water tank.
- Water distribution tubing (see figures 2 and 3).
- Four external fire hose connections through the fuselage lower lobe, two forward and two aft of the wing box.

PRECEDING PAGE BLANK NOT FORMED

Appendix D-1

- System activation and arming switches at attendant stations adjacent no. 1L and no. 4L passenger doors.

Structural and system definition are presented as changes to the reference (a) Basic Airplane:

Payloads/Mechanical Systems

- Add non-metallic water reservoir tank of 43 gallon capacity, station 560 to 620, LH outboard of sidewall liner (see figure 11). Add non-metallic reservoir tank of 40 gallon capacity, station 1650 to 1700 adjacent potable water tank (see figure 10). Tanks are pressurized to 35 psig through nitrogen gas charging port. In addition, tanks are to have fill, overflow, discharge, and drain ports.
- Revise cargo sidewall liner to accommodate station 560 reservoir tank by extending LH doghouse liner aft to approximately station 635.
- Add 3000 psig nitrogen bottle adjacent each water reservoir tank.
- Add maintenance panel adjacent each water reservoir tank. Each panel is to have fill/overflow valve control, drain valve control, water tank level indicator, fill port, and drain/overflow port.
- Add four-way valve to fill/overflow lines for each water tank. Add drain valve to drain lines of each water tank (1" nom.).
- Add 15 psi diaphragm valve, electrically actuated shut off valve (fail open), and back flow valve for discharge lines of each water tank (1" nom.).
- Add squib activated pneumatic pressure regulating valve and pressure relief valve to nitrogen bottle discharge at each water tank. Add pressure tubing from nitrogen tanks to each water tank nitrogen port.
- Add external fire hose connection panels at STA 1670, RBL and LBL 48 and station 510, RBL and LBL 48. (Four

Appendix D-2

connections total, 1-1/2" nominal.) Quick disconnect type coupling with check valve is used.

- Add 1-1/2" nominal aluminum tube feed lines, tying external hose connections to fore and aft header lines (see figure 8). Add 1-1/2" nominal aluminum tube hoop lines tying fore and aft header lines together, stations 510 and 1630. Add frangible couplings, four places, to each hoop line.
- Add 3/4" nominal aluminum tube fore and aft crown header lines, three places, station 297 to 1670. Add 1-1/2" aluminum tube fore and aft header line, stations 510 to 830 and 1190 to 1670, 1" nominal, stations 830 to 1190, LH side below main deck. Add manifolds (having integral frangible check valve couplings--see figure 12) to header lines, on 10 foot centers. Add connecting hoses from manifolds to each nozzle. (See figures 2 and 3.)
- Add 1" nominal aluminum tube intermediate hoop lines, tying fore and aft header lines together, stations 830 and 1190. Add frangible check valve couplings, three places, to each hoop line. (See figure 7.)
- Add fill, overflow, and drain hoses, connecting each water tank to respective maintenance panels.
- Water spray nozzles are added to the bull nose of stowage bins and overhead panels, per figures 6 and 9.

Structures

Body Section 43

- Support structure for forward tank is added to floor beams at station 580 and 620. New structure is to include four vertical links, drag links, corresponding machined fittings, floor beam intercostals, and web reinforcement.
- Support structure for nitrogen bottle is added to frames at station 600 and 620.

Appendix D-3

- Cutout in lower lobe skin station 580 to 600 LBL 45 with skin doubler reinforcement and built up pressure pan and door assembly added for water tank maintenance panel.
- Cutouts in lower lobe skin station 510 RBL and LBL 48 with skin doubler reinforcement and built up pressure pan and door assembly added for external fire hose connections.

Body Section 46

- Support structure for aft tank is added to floor beams at station 1661 and 1681.8. New structure to include four vertical links, drag links, corresponding machined fittings, floor beam intercostals, and web reinforcement.
- Support structure and intercostals for nitrogen bottle added between floor beams at station 1640 and 1661.
- Cutout in lower lobe skin station 1640 to 1661 LBL 15 with skin doubler reinforcement and built up pressure pan and door assembly added for water tank maintenance panel.
- Cutouts in lower lobe skin station 1670 RBL and LBL 48 with skin doubler reinforcement and built up pressure pan and door assembly added for external fire hose connections.

Systems

Flight Deck

- Add a functional test panel (described in electrical section) to flight deck right side panel.

Electrical

- Add a guarded switch to the cabin attendant panels adjacent doors #1L and #4L, to activate nitrogen tank pneumatic valve squibs at forward and aft tanks. Each switch to activate squibs at both tanks.

Appendix D-4

- **Add an electrical arming switch adjacent each activation switch, to control the system solenoid shut off valves and to arm the firing circuit.**
- Add arming circuit between arming switches, forward and aft solenoid shut off valves, and relay switches in forward and aft firing circuits. Solenoid shut off valves are to fail open, with power loss. Firing circuit relay switches are to fail closed, with power loss.
- Add firing circuits between cabin activation switch, arming circuit relay switch, dedicated battery, and nitrogen bottle squib, for forward and aft systems. Forward and aft circuits to be cross connected to allow either forward or aft switches to activate both forward and aft squibs. Dedicated nickel cadmium batteries to be provided for both forward and aft circuits, with charging provisions.
- Add functional test panel to flight deck and each maintenance panel to provide check of firing circuit continuity, dedicated battery charge, forward and aft tank levels, and nitrogen bottle pressures--with pass verification, and failure indication.
- Safety related electronic boxes, relay panels, and wire integration centers to have drip shields added against potential water drippage.

Revision A: Delete arming switch from flight deck. Add arming switch adjacent each activation switch.

Appendix D-5

List of Figures

<u>Figure No</u>	<u>Title</u>
1	Cabin Water Spray System Isometric Model 761-650
2	Schematic Forward Distribution System Model 761-650
3	Schematic Aft Distribution System Model 761-650
4	Schematic Forward Reservoir Tank Model 761-650
5	Schematic Aft Reservoir Tank Model 761-650
6	Nozzle Arrangement Model 761-650
7	Section Sta. 1190 Nozzle & Hoop Line Arr. Model 761-650
8	Section Sta. 1630 - External Hose Connection Model 761-650
9	Section Typical Nozzle Arrangement Model 761-650
10	Aft Tank Arrangement Model 761-650
11	Fwd Tank Arrangement Model 761-650
12	Possible Coupling and Manifold Arrangement

Appendix D-6

CABIN WATER SPRAY SYSTEM ISOMETRIC

MODEL 761-650

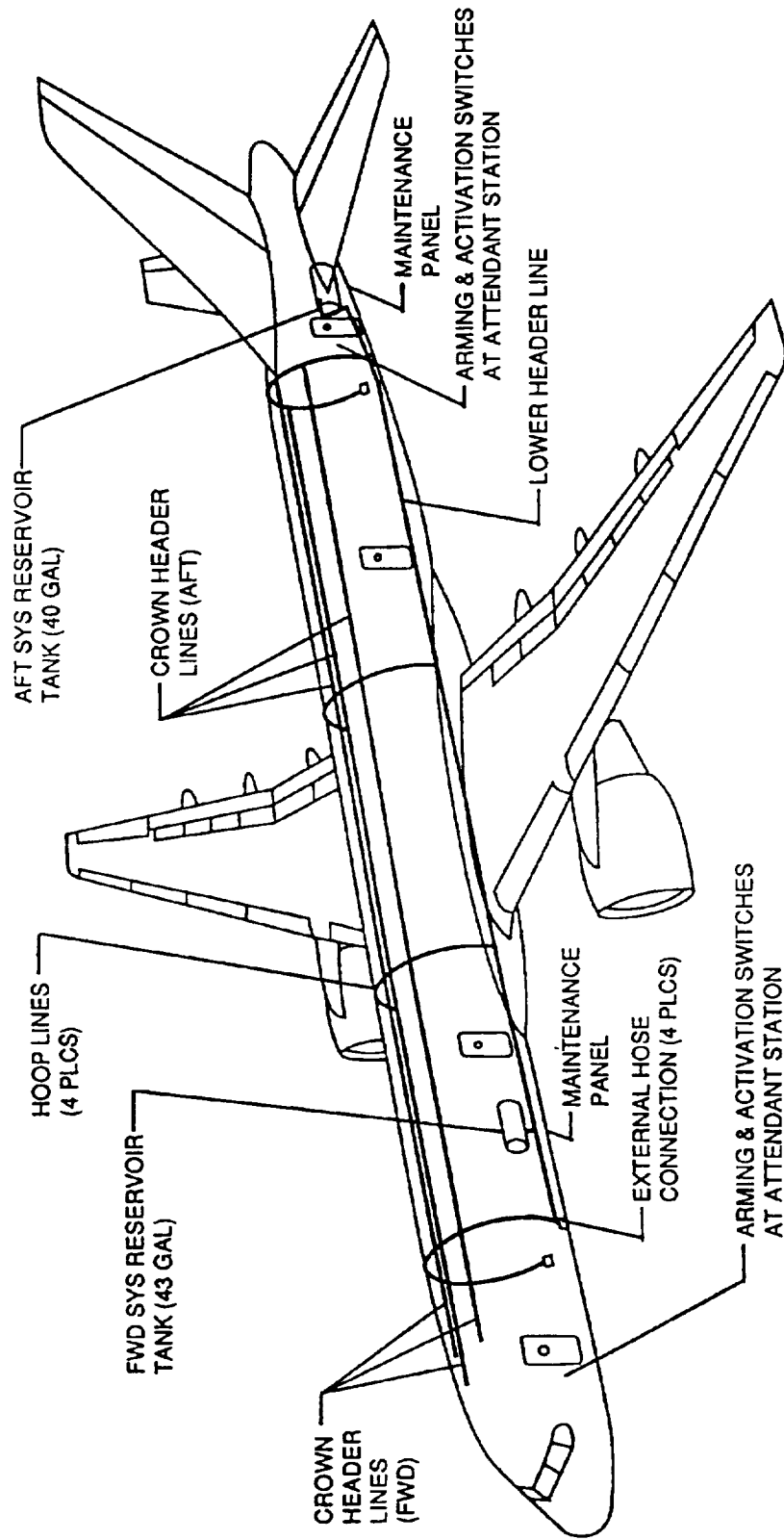

Figure 1

CD-165-1
RPD-101988

Appendix D-7

SCHEMATIC FWD DISTRIBUTION SYSTEM MODEL 761-650

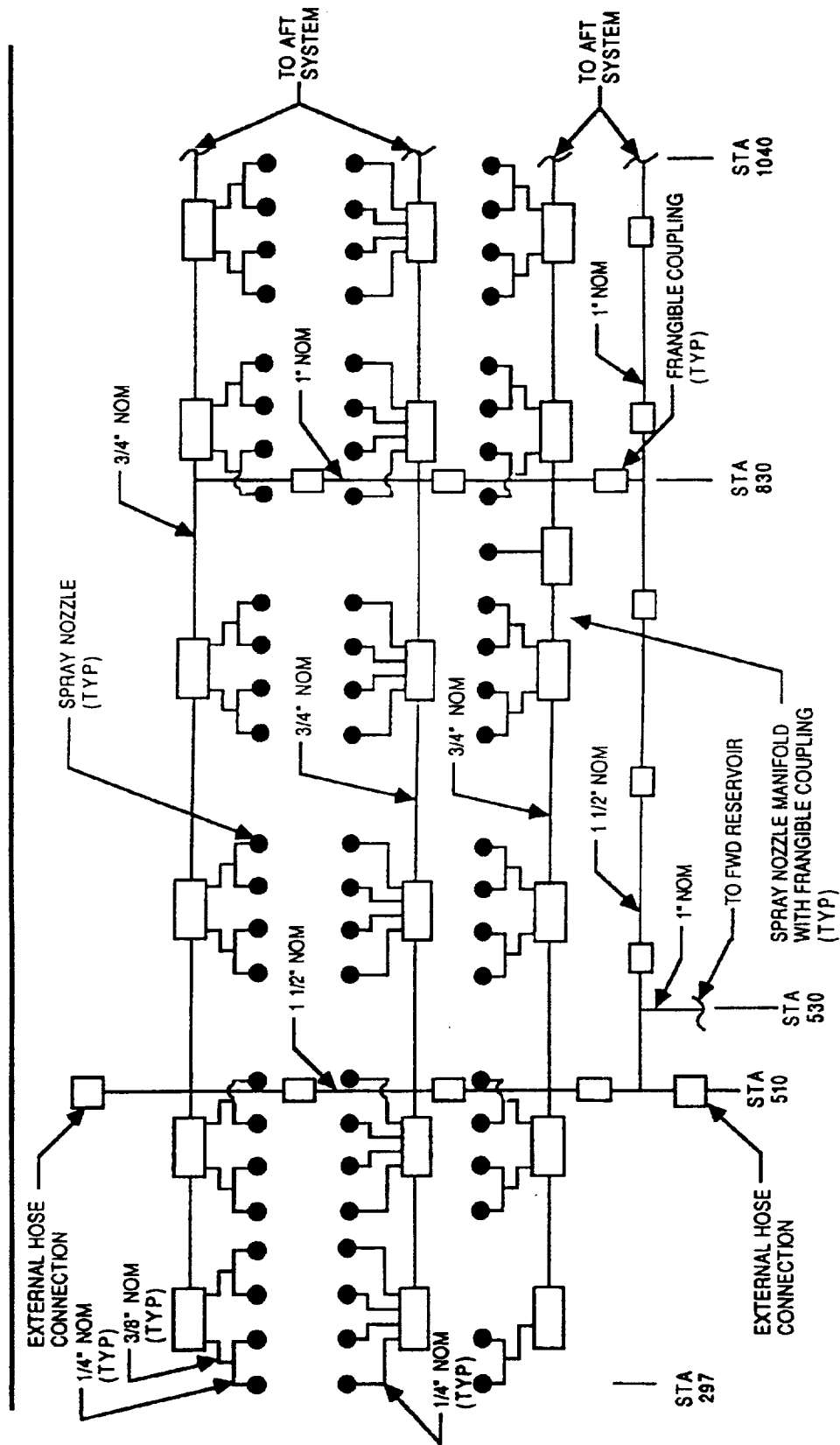

Figure 2

CD-156-1
RPD-101388

SCHEMATIC AFT DISTRIBUTION SYSTEM MODEL 761-650

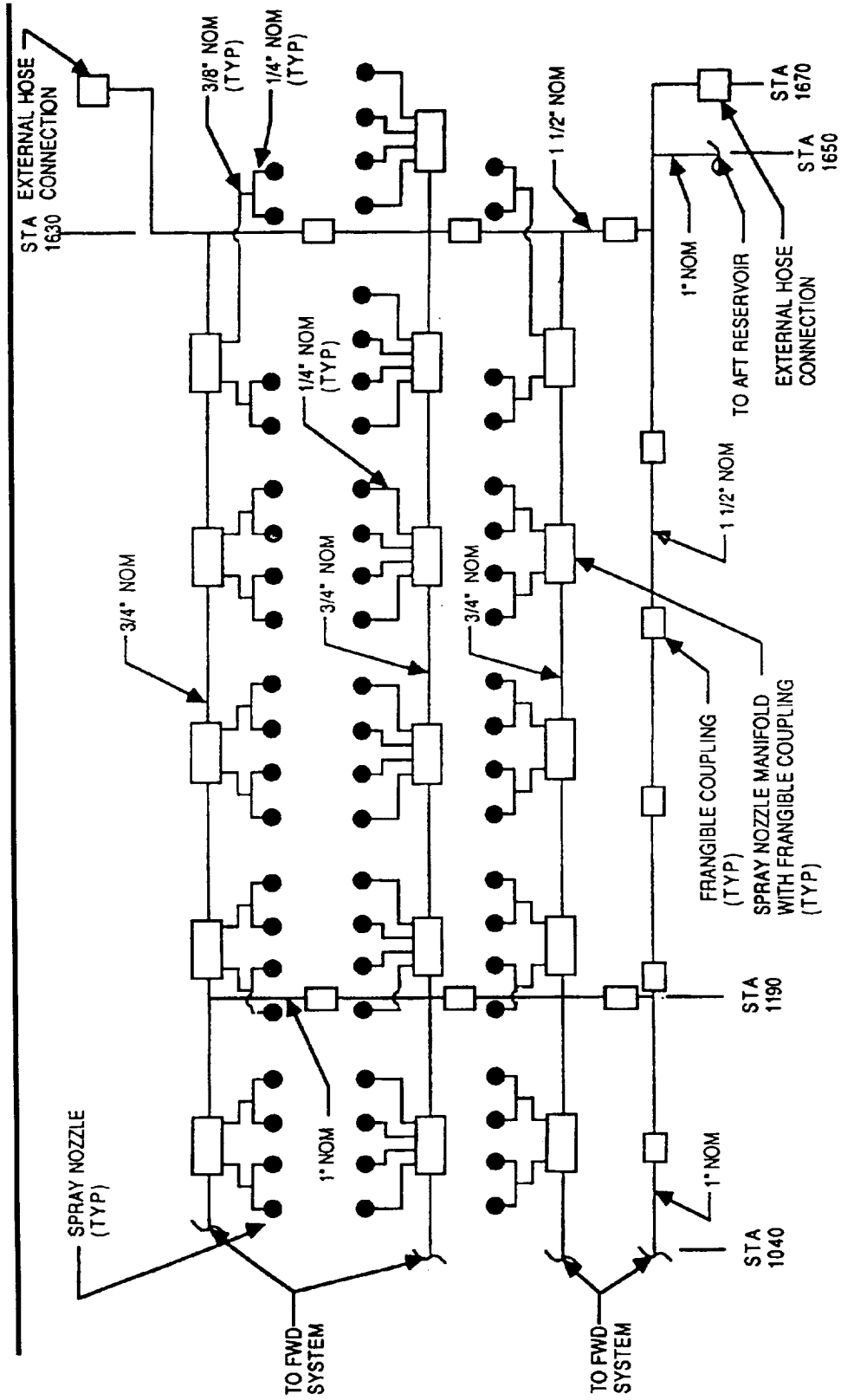

Figure 3

CD-157-1
RPD-101388

SCHEMATIC FWD RESERVOIR TANK

MODEL 761-650

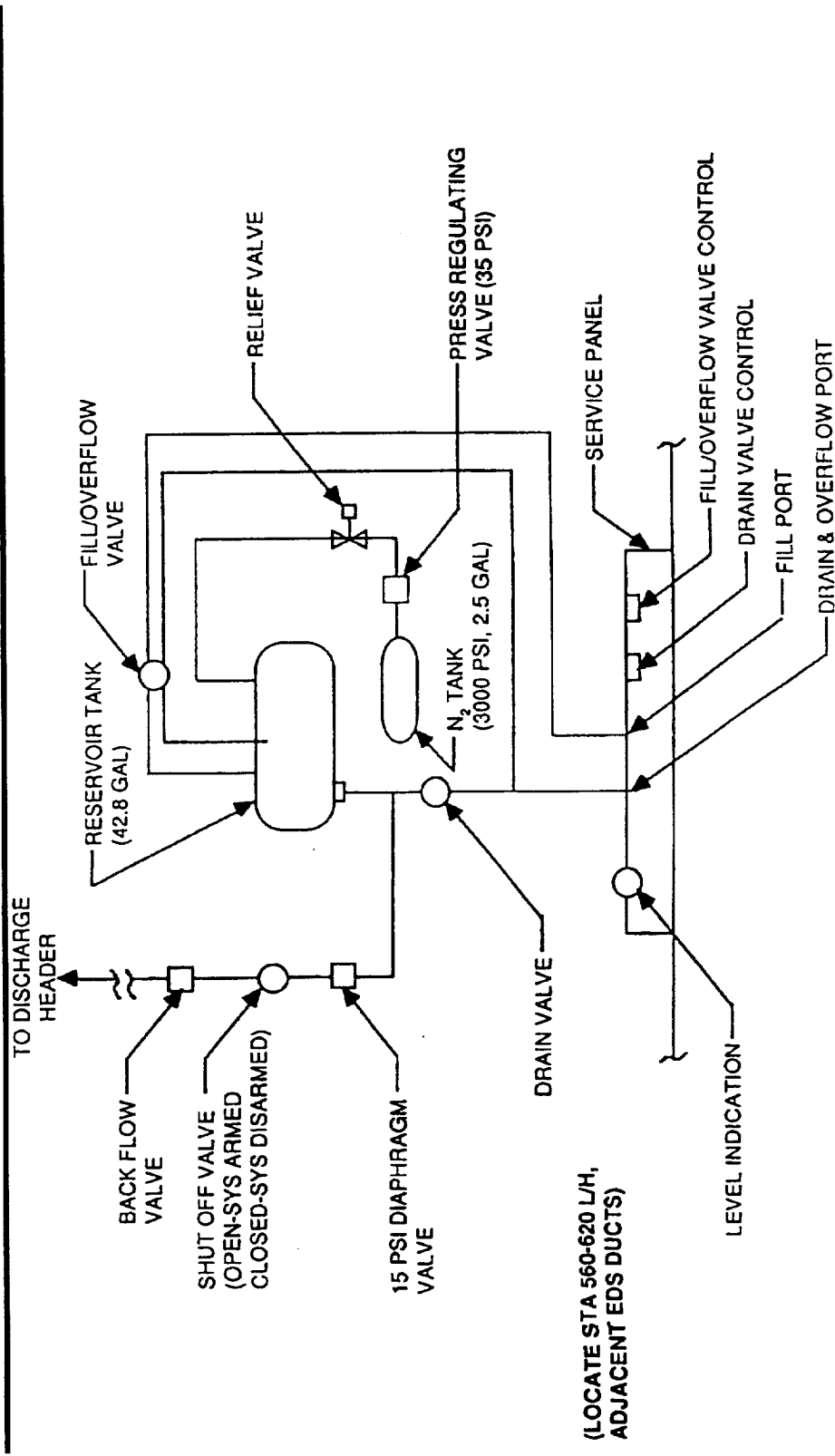

Figure 4

CD-151-1
RPD-092186

SCHEMATIC AFT RESERVOIR TANK MODEL 761-650

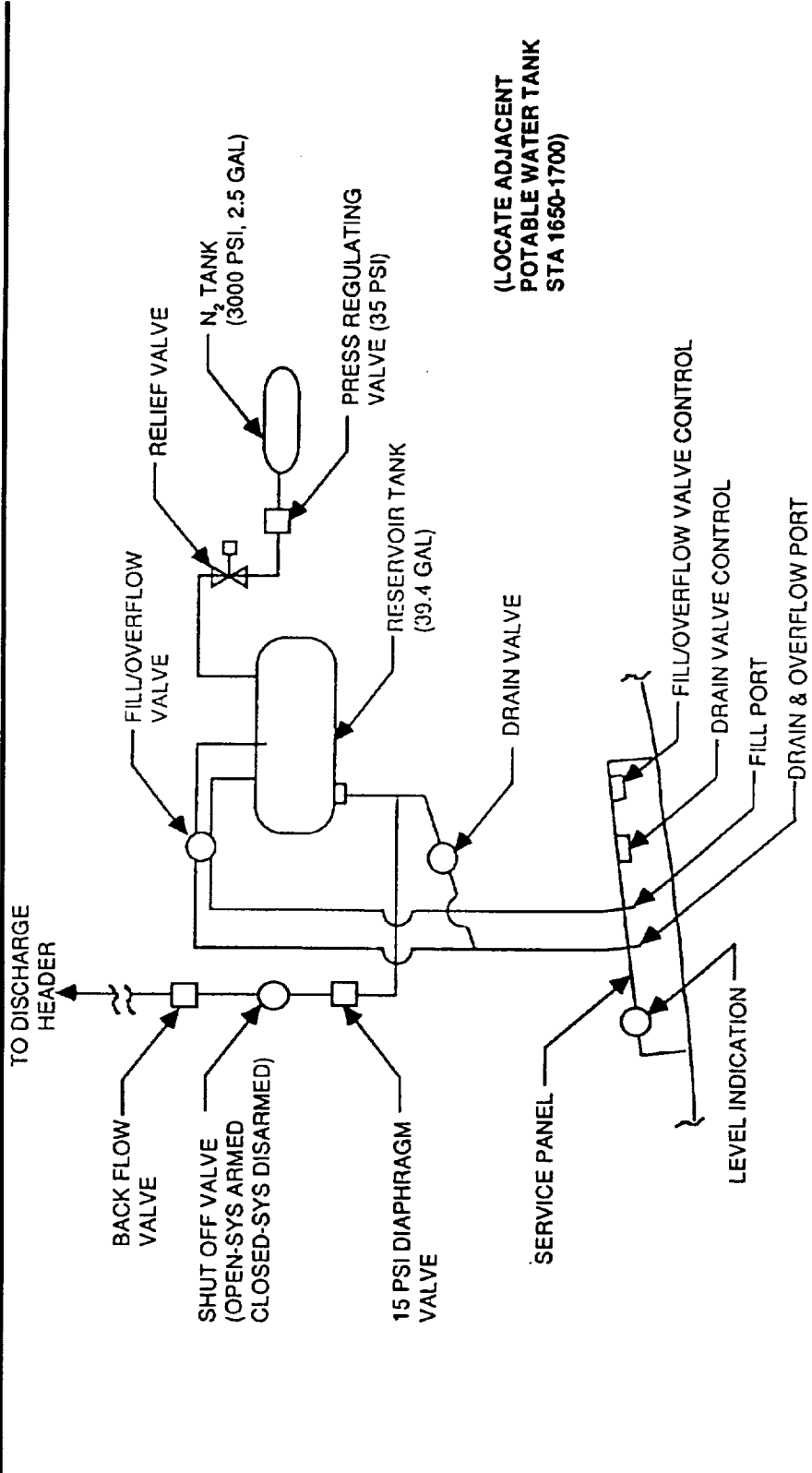
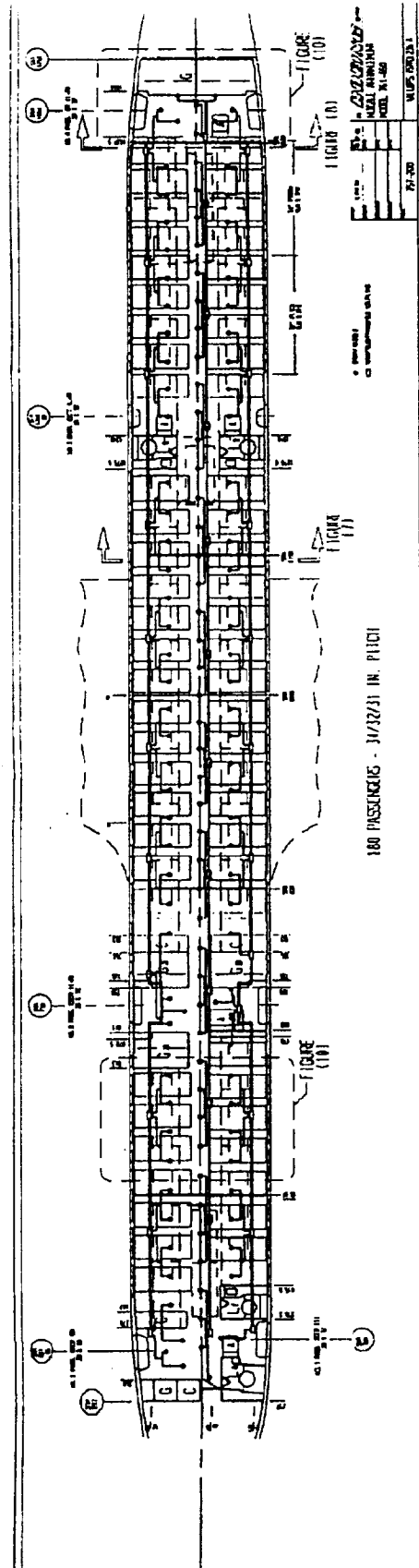

Figure 5

CD-150-1
RPD-092188

Appendix D-11

Figure 6



SECTION STA 1190 NOZZLE & HOOP LINE ARRANGEMENT
MODEL 761-651

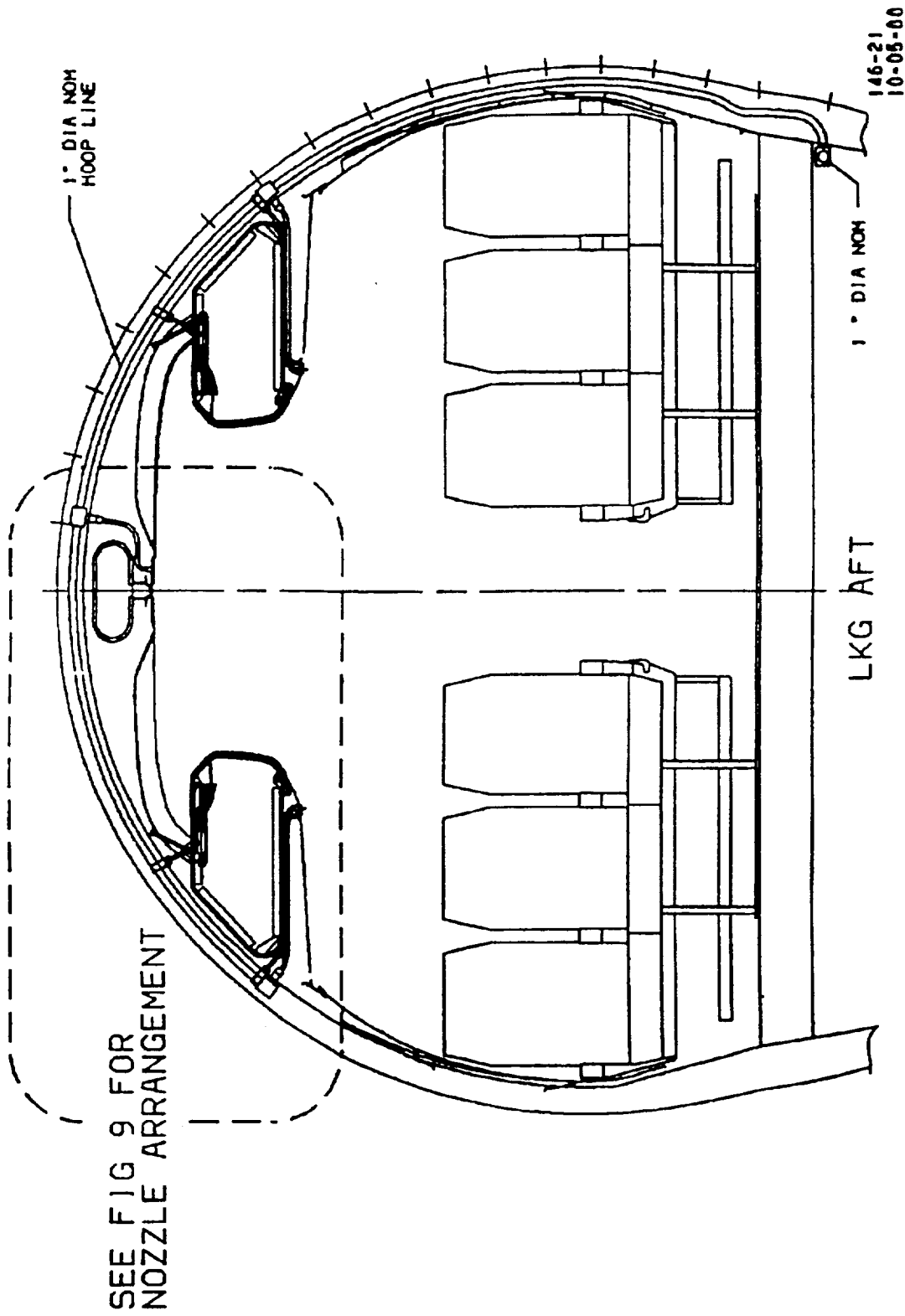

Figure 7

Appendix D-13

SECTION STA 1630 - EXTERNAL HOSE CONNECTION
 MODEL 761-650

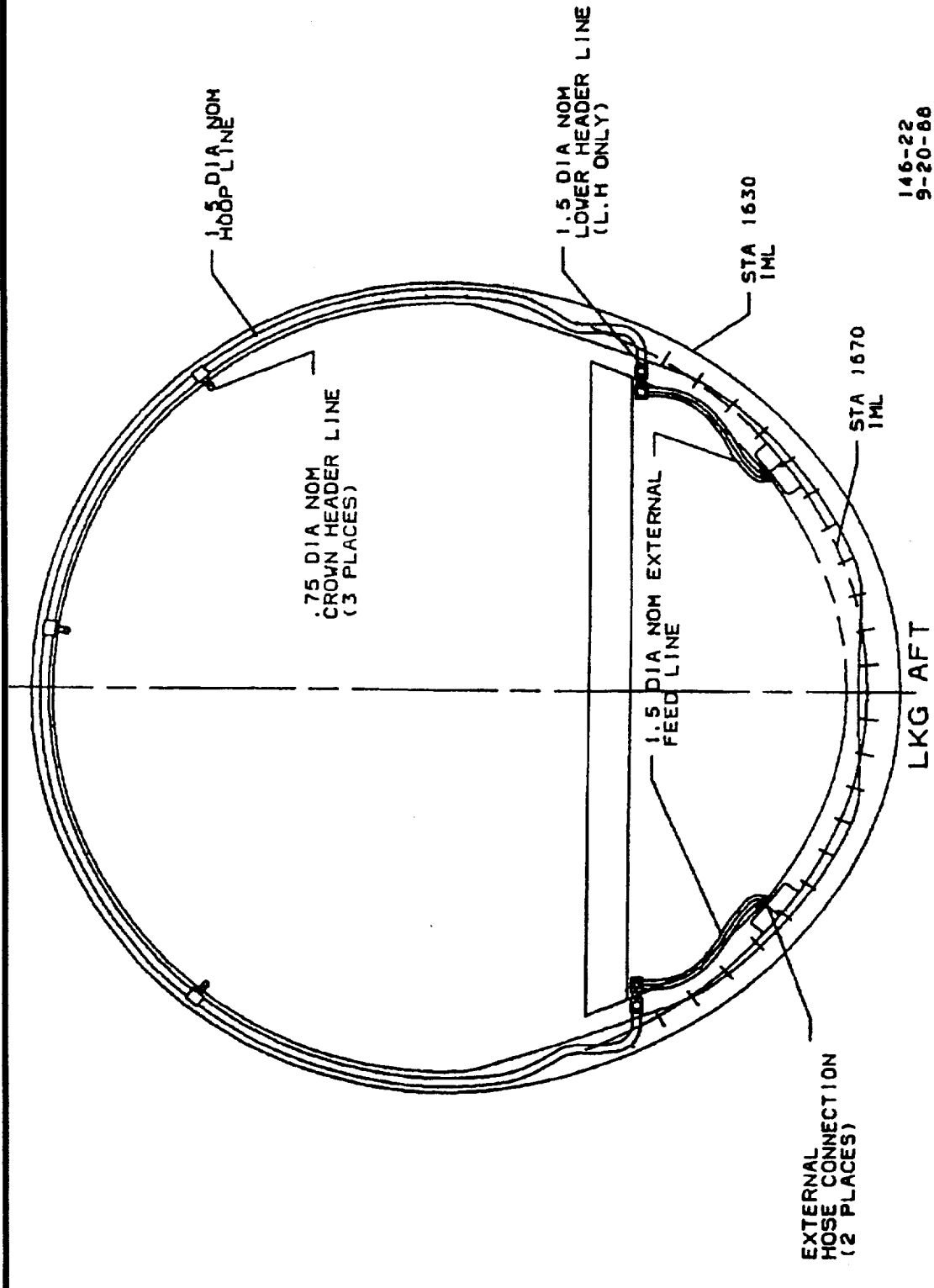

Figure 8

146-22
 9-20-66

Appendix D-14

SECTION TYPICAL NOZZLE ARRANGEMENT MODEL 761-651

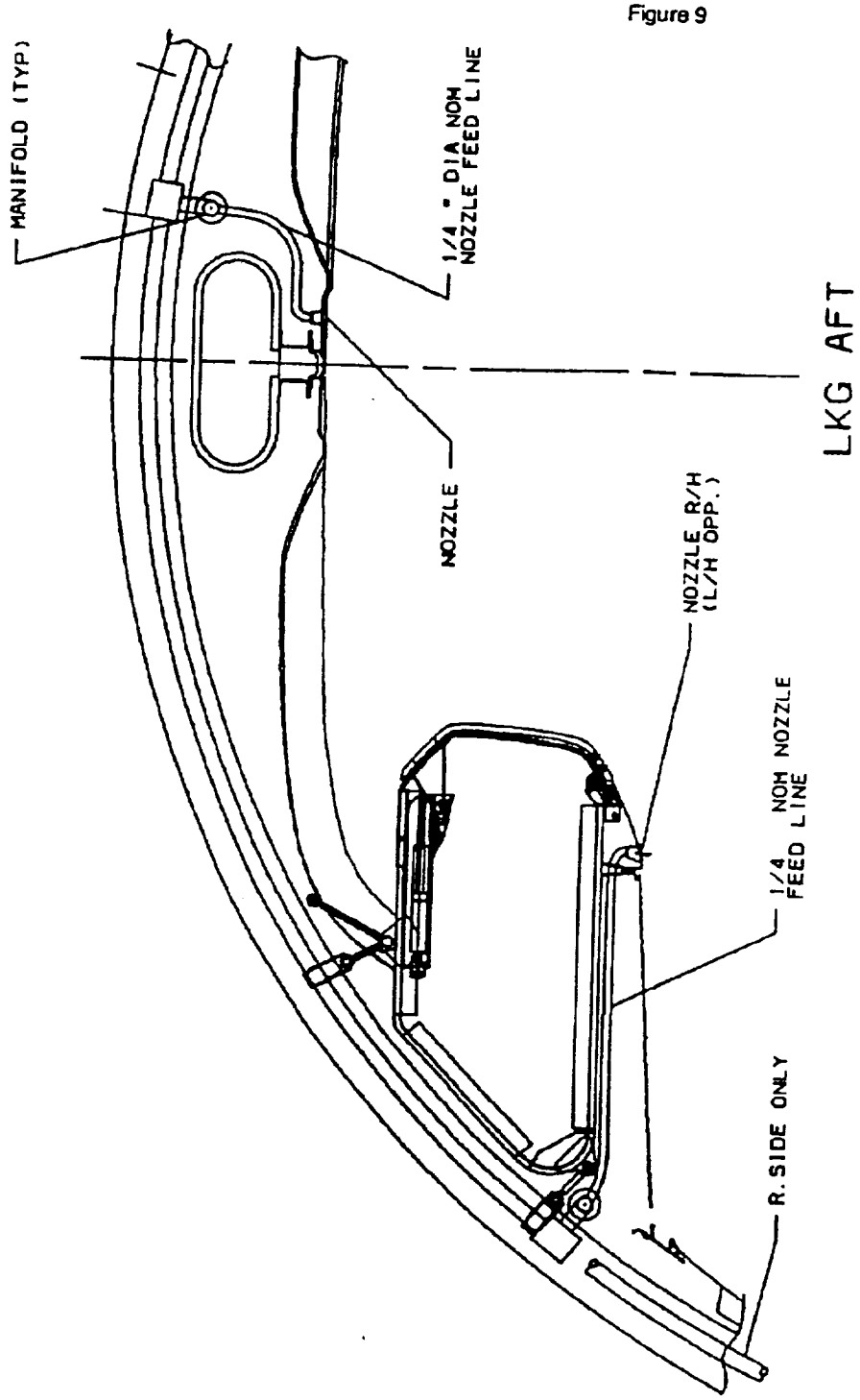

Figure 9

146-23
10-05-66

* XSECT WATER S. A. V. F. SYSTEM

Appendix D-15

Figure 11

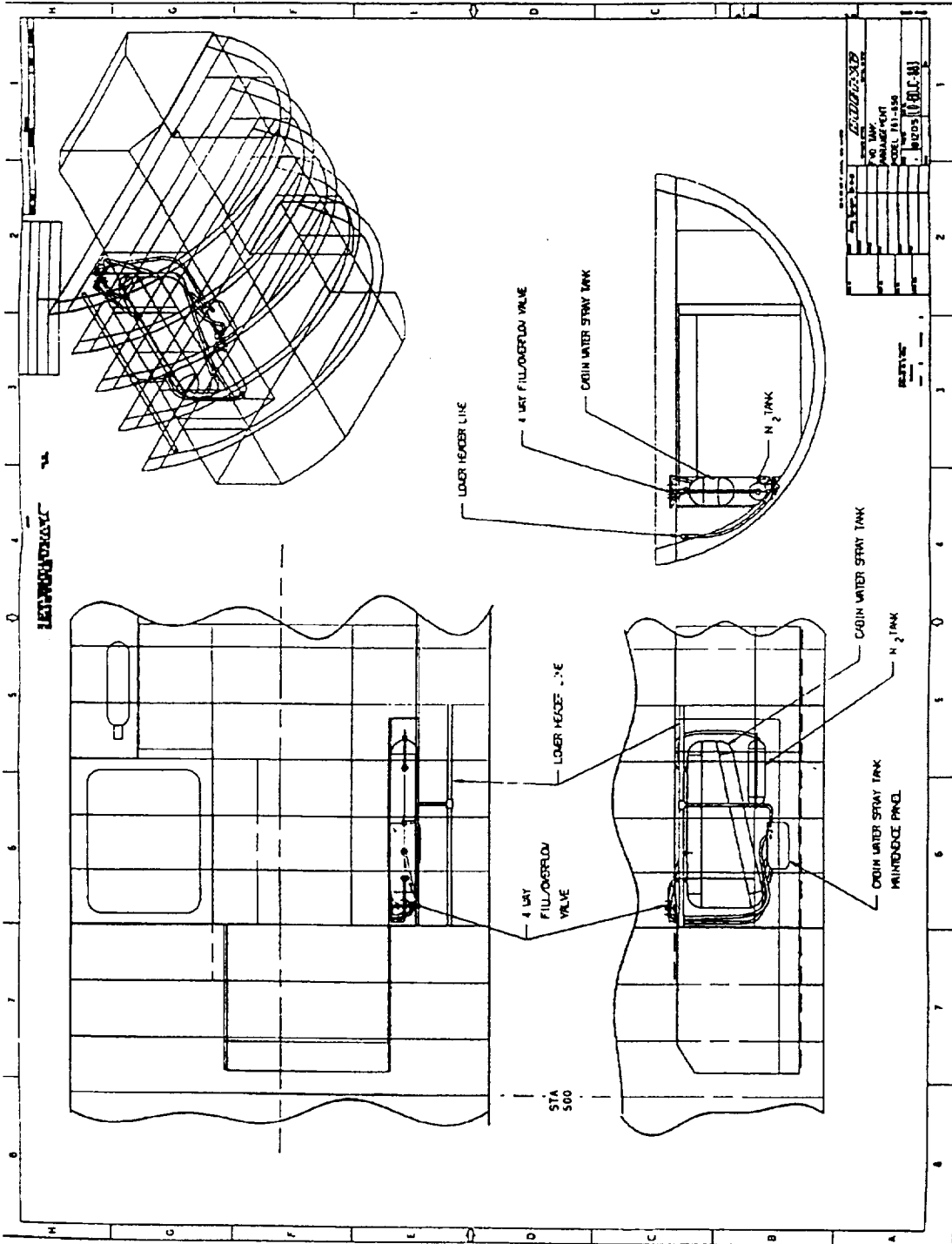

Appendix D-17

Figure 12

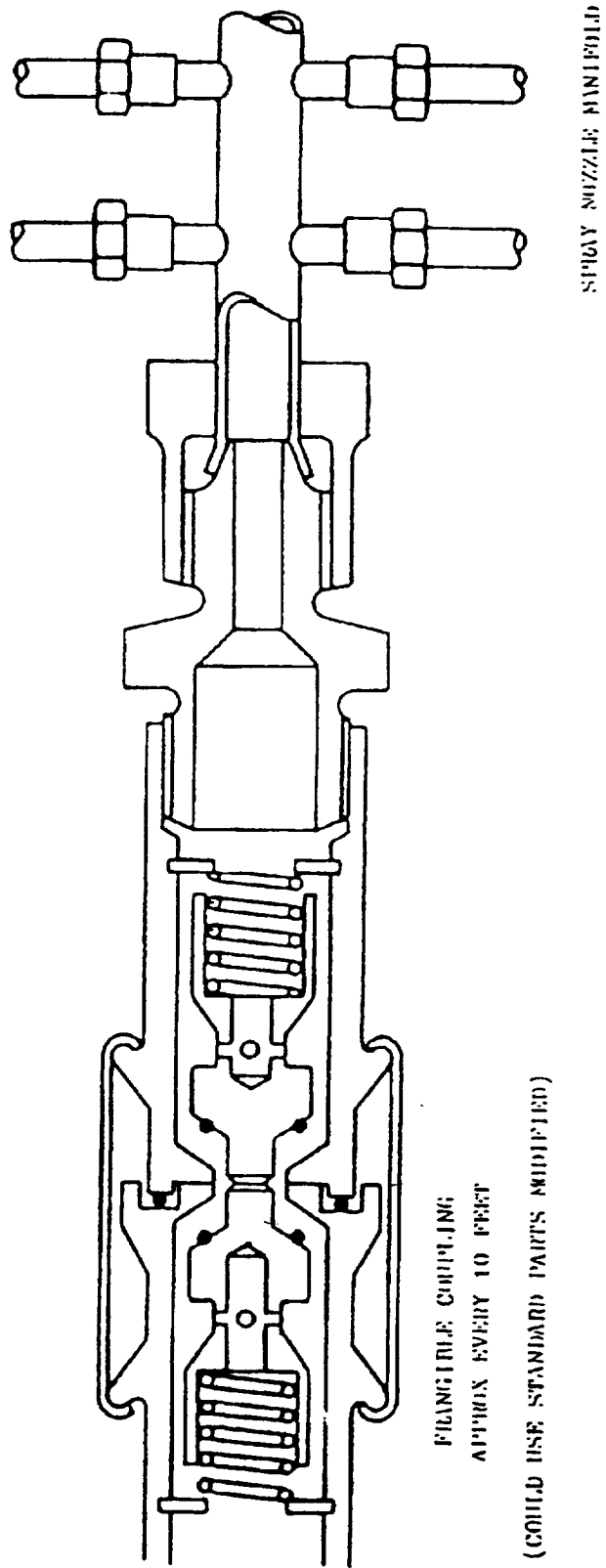

FLANGE COUPLING
APPROX EVERY 10 FEET
(COULD USE STANDARD PARTS MODIFIED)

SPRAY NOZZLE MANIFOLD

POSSIBLE COUPLING AND MANIFOLD ARRANGEMENT

Appendix E
Human Factors –
A Review of Two
Selected Reports

PAGE _____ INTENTIONALLY BLANK

THE MANCHESTER, ENGLAND, COMMERCIAL AIRPLANE ACCIDENT

On August 22, 1985 at 0612 hours a Boeing 737-236 with 131 passengers and 6 crew onboard began rollout on the active runway at Manchester, England, UK. Thirty-two seconds into the rollout a compressor ejected from the No. 2 engine piercing the fuel tank and throwing fuel on the hot engine. The takeoff was immediately aborted and the airplane turned off the runway (44-seconds). Although rescue arrived very promptly 54 people died immediately. Subsequently one passenger who was removed from the wreckage 4.5-minutes later survived but one rescued 34-minutes later died 6 days later. All of the survivors appear to have exited the airplane within 4-minutes of the flight starting (rollout). The first paper reviewed below is a medical analysis of this accident followed by a second paper which draws behavioral conclusions from this and other life-threatening emergencies.

“AN ANALYSIS OF FACTORS IMPEDING PASSENGER ESCAPE FROM AIRCRAFT FIRES”,
I. R. HILL, AVIATION, SPACE AND ENVIRONMENTAL MEDICINE 61:261-265, 1990

THE MANCHESTER ACCIDENT

“The early entry of smoke and flames into the cabin caused panic; some people collapsed, others scrambled over seats which collapsed. The aisles and exits became blocked; and two passengers refused to leave by the left front door. The crew did not use their smoke hoods, and the PA system did not work because it was linked to the failed No. 2 engine.”

EVACUATION IN THE MANCHESTER ACCIDENT

Fifty (50) of the survivors said they had trouble getting out of the airplane:

- Due to the crush of panicked passengers;
- Those who were not delayed in escape were seated in first 2 rows or near the right overwing exit;
- Almost all survivors said they had trouble breathing.

Incapacitation of people was caused primarily by:

- Carbon monoxide and cyanide which cause hypoxia (lack of oxygen to tissues of the body) - often called narcosis;
- Heat and toxic particles which cause visual and respiratory tract irritation and behavioral problems.

CAUSES OF DEATH IN THE MANCHESTER ACCIDENTS

- 0 - from mechanical trauma;
- 9 - heat;
- 4 - CO;
- 11 - HCN;
- 10 - CO + HCN;
- 20 - combination of toxins plus heat.

Appendix E-1

SOME OF THE AUTHOR'S RECOMMENDATIONS

- Provide passenger with upper torso restraint;
- Provide passenger with smoke hoods/masks;
- Floor level lighting should be installed, etc.

This analyst made no mention of a water spray system (Hill is from Royal Air Force Institute of Pathology in England, UK), and has since stated his reservations regarding water spray systems (Reference 3).

**"HUMAN FACTORS IN CABIN SAFETY", HELEN C. MUIR AND CLAIRE MORRISON,
CABIN CREW SAFETY/FLIGHT SAFETY FOUNDATION 25(2), MARCH, 1990**

- "In a situation where an immediate threat to life is perceived, rather than all passengers being motivated to help each other, the main objective that will govern their behavior will be survival for themselves, and in some instances, members of their family. In this situation, people do not work collaboratively and evacuation can become very disorganized."
- "The scientific literature indicates that where there is a serious threat to life, and only a limited opportunity for escape, not only is everyone very frightened but it is human nature for individuals to compete with each other in order to survive—in the Zeebrugge disaster some adults pulled children off life rafts in order to survive."
- Staged evacuation drills and some real world accidents are usually orderly. But in most aircraft accidents the orderly process was not adhered to, and confusion resulted in blockages in the aisles and exits, often with a consequent loss of life;
 - Some passengers do not exit by their nearest exit but travel for considerable distances, i.e., from front to back. Why do they choose to do this?
 - Some passengers near exits do not survive. Do they panic, freeze up, give up, get crushed by other people, etc.?
 - Blockages have occurred in the aisles and exits in some actual accidents—this does not occur in evacuation demonstrations staged for certification

Appendix E-2

