

N94-22765

Geostationary Payload Concepts for Personal Satellite Communications

J. Benedicto, P. Rinous, I. Roberts,
A. Roederer, I. Stojkovic
European Space Agency - ESTEC
Keplerlaan 1, P.O. Box 299
2200 AG Noordwijk
The Netherlands
Tel. +31-1719-86555
Fax. +31-1719-84596

ABSTRACT

This paper reviews candidate satellite payload architectures for systems providing world-wide communication services to mobile users equipped with hand-held terminals based on large geostationary satellites.

There are a number of problems related to the payload architecture, on-board routing and beamforming, and the design of the S-band Tx and L-band Rx antenna and front ends. A number of solutions are outlined, based on trade-offs with respect to the most significant performance parameters such as capacity, G/T, flexibility of routing traffic to beams and re-configuration of the spot-beam coverage, and payload mass and power.

Candidate antenna and front-end configurations were studied, in particular direct radiating arrays, arrays magnified by a reflector and active focused reflectors with overlapping feed clusters for both transmit (multimatrix) and receive (beam synthesis).

Regarding the on-board routing and beamforming sub-systems, analogue techniques based on banks of SAW filters, FET or CMOS switches and cross-bar fixed and variable beamforming are compared with a hybrid analogue/digital approach based on Chirp Fourier Transform (CFT) demultiplexer combined with digital beamforming or a fully digital processor implementation, also based on CFT demultiplexing.

INTRODUCTION

Land-mobile satellite communications is evolving towards providing compatibility with the services offered by terrestrial cellular personal communication systems, and complementing them in low population density areas where terrestrial coverage cannot be provided economically.

Offering the user world-wide roaming capability (as is intended in an FPLMTS context) requires integrating terrestrial and satellite networks and a user terminal capable of operating within both of them (frequently referred to as "dual-mode terminal"). This requires the

development of satellite user terminals adapted to each application, such as vehicle-mounted terminals (VH), portable laptop terminals (PT), and pocket size hand-held telephones (HH). Existing L-band VH and PT terminals (for instance INMARSAT-M) are compatible with the current INMARSAT-II spacecraft and other satellites now in construction such as MSAT, INMARSAT-III, the EMS payload on ITALSAT-F2 and the LLM payload on-board ESA's satellite ARTEMIS. Satellite HH terminals have not been developed so far.

At its last conference (WARC'92) the ITU allocated new frequency bands to the mobile satellite service, from 1613.8-1626.5MHz (Earth-to-space) and 2483.5-2500MHz (space-to-Earth). These new allocations were primarily implemented for future satellite systems for HH voice communication, based on non-GSO satellites (so-called big LEOs) like the IRIDIUM, GLOBALSTAR, ODYSSEY, ELLIPSO and CONSTELLATION systems. The technical choice (non-GSO satellites) made for those systems is based on the belief that providing good quality voice and data communication services to HH terminals is far beyond the easy reach of GSO satellites. Nevertheless, some studies [1] have shown that although GSO satellites for HH communications are very large and complex, they could be implemented before the end of this century.

ESA is actively pursuing system studies and technology developments by different technical solutions based on GSO, Medium Earth Orbit (MEO) [2], Low Earth Orbit (LEO) and Highly inclined Elliptical Orbits (HEO) [3].

This paper summarises the results of internal studies performed to size a GSO payload for HH communication. Section 1 outlines the system background, section 2 describes the payload architectures studied and associated technologies, section 3 describes satellite mobile link antennas based on large unfurlable reflectors and deployable phased arrays and section 4 gives the overall payload configuration and system budgets for the selected option.

1. SYSTEM BACKGROUND

The satellite system considered here is for land-mobile personal communication, in particular to users equipped with HH terminals, using the recently allocated frequency bands in the L and S-bands.

USER	MOBILITY	TERMINAL	CO-OPERATION
Traveller	open/shadow	HH dual mode	High
Mobile	mobile chn.	VH dual mode	Low
Government	mob./outdoor	HH, VH	High
Remote Telephony	outdoor	HH, portable PT or VH	High
Recreational	land/sea	HH	Low
Data Collection	outdoor	semi-fixed	High

A definition of the user categories and telecommunication services to be provided is given in Table 1. A variety of user terminals have been conceived (Table 2) to match the different user needs for mobility and transportability. Two parameters are of paramount importance when designing the mobile terminal for a given user application: the antenna (gain and profile) and the transmitted RF power. The antenna radiation pattern (and gain) has to be adapted to the problems of user mobility and hence possible degree of co-operation in pointing towards the satellite. The antenna profile and size is crucial to the terminal integration in a vehicle, suitcase, or for an ergonomic hand-held design. The transmitted RF power will have an effect on the DC power demand and therefore the size of the batteries required (transportability). In addition to that are the short and long term safety aspects for the user related to the biological effects of the radiated fields, especially for a HH-type terminal.

	hand-held	portable	vehicle
size	pocket	laptop	antenna + set
antenna gain	0 ~ 3dBi	+7dBi	+4dBi
Tx RF power	< 500mW	1W	2W
EIRP [dBW]	-3 ~ 0	+7	+7
G/T [dB/K]	-24 ~ -21	-17	-20

The most relevant system parameters are summarised in Table 3. The satellite has been sized to provide the equivalent of 5000 voice (2.4Kb/s coding rate) circuits to HH terminals over the land masses and coastal waters of the geographical areas from which the satellite is seen with more than 10° of elevation angle.

Orbital position	GSO, 20° East
Coverage of land masses only	
Min. elevation for coverage	10°
Launch date	year 1998 - 2000
Lifetime (with 85% reliability)	10 years
Mobile frequencies, downlink	2483.5MHz - 2500.0MHz
Mobile frequencies, uplink	1613.8MHz - 1626.5MHz
Frequency re-use	2.5 (average)
Satellite throughput	5000 voice circuits
Voice activation	40%, both ways
Access	FDMA, 4KHz channels
Required link quality, C/No	39dBHz
Reference Terminal G/T (HH)	-24dB/K
Reference Terminal EIRP (HH)	-3dBW
Satellite EIRP (S-band)	62.6dBW
Satellite G/T (L-band)	+6.1dB/K

The forward and return link budgets are summarised in Table 4. The antenna coverages have been optimised for a satellite located at 20° East (over the European/African region). The margins in the link with the mobile users assume line-of-sight communication with C/M better than 5dB (Ricean channel).

Forward down link (2.5GHz)	
EIRP/channel	29.6dBW
Satellite Tx antenna gain (*)	33.0dBi
Satellite power/channel	-4.4dBW
Number of activated channels	2000
Satellite EIRP (total)	62.6dBW
Path loss	-192.5dB
Atmospheric loss	-0.15dB
CCI interference loss	-1.0dB
C/M loss	-1.0dB
HH terminal G/T	-24.0dB/K
Received C/No	39.5dBHz
Overall forward link C/No	39.0dBHz
Margin (ref. 39dBHz)	0.0dB
Return up link (1.6265GHz)	
HH terminal EIRP	-3.0dBW
Path loss	-188.8dB
Atmospheric loss	-0.1dB
C/M loss	-1.0dB
CCI interference loss	-1.0dB
Satellite Rx antenna gain (*)	34.0dBi
Satellite system temperature	27.9dBK
Satellite G/T (at L-band)	+6.1dB/K
Received C/No at satellite	40.7dBHz
Overall return link C/No	40.2dBHz
Margin (ref. 39dBHz)	+1.2dB
(*) includes Tx and Rx losses	

2. REPEATER ARCHITECTURES

The repeater includes the feeder link interface sub-system, the payload processor and the Tx and Rx mobile link sub-systems. The payload processor performs routing, switching and beamforming. The primary driver for the processor is the large number of beams for the required coverage. This has a major impact on both channelisation and beamforming, but the advantages in on-board power saving, increased frequency re-use potential and improved satellite G/T are significant for this application. Other design drivers which have to be considered are: 1) large number of feeds (having an impact on switching and beamforming); 2) frequency re-use flexibility (easily implemented in a digital processor, but requires local oscillator tunability in an analogue one); 3) total capacity; 4) traffic routing flexibility; 5) fine channelisation for granularity, to reduce beam blocking probability; 6) possibility to rearrange the frequency plan in orbit; and last, but not least, 7) reliability (bearing in mind the fact that massive and complex processors lead to massive redundancy requirements). Three generic types of payload processors were considered and a detailed trade-off between them was performed.

SAW + Analogue BFN

This is a fully transparent processor based on group demultiplexing by SAW filter banks. The beamforming enables a limited number of spot beams to be generated giving contiguous coverage. This is a well known design used in many existing systems e.g. INMARSAT III, EMS and LLM payload on ARTEMIS. The main advantages of such a design are, besides the mentioned transparent group demultiplexing, power and bandwidth flexibility and the ability to handle any type of modulation, whereas the limitations are on matching traffic to beams (due to filtering granularity) and frequency re-use.

CFT + Analogue BFN

This payload processor is characterised by time domain analogue demultiplexing (which is enabled by the Chirp Fourier Transform), possibly enhanced by additional fine digital channelisation (if very narrow bandwidths, below 100KHz, are required), followed by an analogue beamforming network. The main features of all CFT based repeaters are low granularity, which can go down to very small channel groups (in case of FDMA) or to individual carriers (in case of a TDMA access scheme), simple and flexible L and S-band in-orbit frequency plan re-arrangement and the possibility to have a compressed feeder spectrum without the need to map the feeder to mobile spectrum.

CFT + Digital BFN

This processor is based on SS-FDMA concept of transponder channel switching, but is easily adapted for use with TDMA or CDMA access schemes, due to its transparent nature. The routing function is performed in principal on a channel-by-channel or carrier-by-carrier basis, using a demultiplexer implemented in hybrid CFT technology enhanced by digital demultiplexing [4]. In many cases, however, the ultimate channelisation down to single user circuit is not needed and significant reductions in processing load can be achieved by demultiplexing down to small groups of channels (typically 20 to 30 circuits), without noticeably degrading the overall performance. The coverage is achieved by a large number of narrowband repositionable overlapped beams. Beamforming is digital narrowband i.e. performed on a limited number of channels or carriers. There is a possibility to perform individual channel processing including on-board level control to save downlink RF power and active interference suppression to maximise frequency re-use. Total control of feed element signals enables beam re-configuration in case of failure or misalignment.

Accurate user location for beam pointing is a necessity, if the advantages of beam repositioning are to be utilised. Digital beamforming lends itself well to direction finding algorithms, which can be implemented in the return processor for this purpose. Other networking implications following from this design approach are mobile to mobile link service, adaptability to variations of traffic distribution and transparency for introduction of new services.

In summary, the main advantages are maximised routing flexibility, best frequency re-use capability, high RF power efficiency (due to near-peak antenna gain and possible power control), compact feeder link and, of major importance for service to hand-held terminals, peak satellite G/T. The single most significant disadvantage is that a processor of this type has not been flown before whilst it is based on technology which still needs to be developed to space standard.

Mobile and Feeder Link Subsystems

Due to the high incidence of components involved in mobile antenna feed element chains, significant advantages in payload mass and DC power consumption can be expected from their improvements. In particular integration and miniaturisation is needed for low-loss output combiners (semi-active antenna) and bandpass filters, very low noise figure L-band LNAs integrated with bandpass filters, and high efficiency medium-power S-band SSPAs.

The feeder link sub-system is not described in detail, because of its commonality with previous designs. An

estimate of mass and DC power requirement for this sub-system is, nevertheless, presented in Table 5.

3. S/C ANTENNA DESIGN

The spacecraft multibeam antennas are required to provide reconfigurable coverage of land masses from several positions on the geosynchronous orbit and to accommodate changes in traffic to beams, with maximum DC to RF efficiency. Over 33dB gain is required in both the forward and return links, with 20dB sidelobe isolation for frequency re-use. It is further assumed that the same beam footprints are used for the up and down links.

Direct Radiating Arrays

Active arrays can provide the required flexibility. The use of separate transmit and receive antennas is conceptually simpler than the re-use of the same aperture, but implies complex deployment. For the same aperture, either interleaved or co-located (dual frequency) elements are possible. A configuration with separate antennas, 8m×2.7m at L-band for receive and 5.1m×1.7m at S-band for transmit, each with 192 subarrays of electromagnetically coupled annular slots, has been evaluated. The beams are elliptical and, even with optimum sub-arraying, sidelobe control requires a power inefficient excitation taper or use of different amplifiers. Beamforming is complex since all elements are involved for each beam.

Reflector Antennas

Multifeed reflector antennas are the other alternative. In the receive mode, where amplitude control at feed level has no power efficiency impact, focusing reflector antennas using *beam synthesis* [5] lead to the smallest feed and reflector sizes. Each beam is formed by optimal weighting of pre-amplified signals from only some of the feeds.

For transmit, amplifiers must operate close to nominal power for optimum DC to RF efficiency.

Active focusing reflector antennas, with overlapping feed clusters, and one power amplifier at each feed require complex power switching to cope with changes in beam loading. Imaging antennas [6] where a feed array is magnified by one or two reflectors, suffer from reflector oversizing and require inefficient feed illumination tapering for sidelobe control.

One preferred option is *semi-active multimatrix* antennas [7,8], as used for the INMARSAT III series, which provide the required performance with optimum power efficiency, together with minimum reflector and feed sizes. The same feeds are shared between several beams and are powered from identical amplifiers via Butler-like matrices, which direct the power towards the selected outputs depending on their input phase law.

A design with 35λ by 49λ (4.2m×5.8m at S-band) offset reflector ($F/D=0.5$) and a 128 element feed array

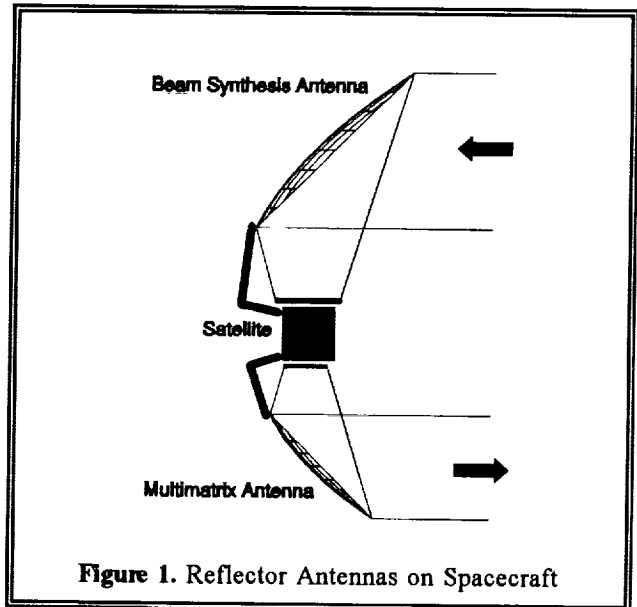

Figure 1. Reflector Antennas on Spacecraft

placed on the satellite wall (Figure 1) fed via 16 8×8 hybrid matrices (Figure 2) has been analysed for global coverage. As only land mass and 10° elevation coverage is required, the number of feeds and matrices is reduced accordingly, but not shown.

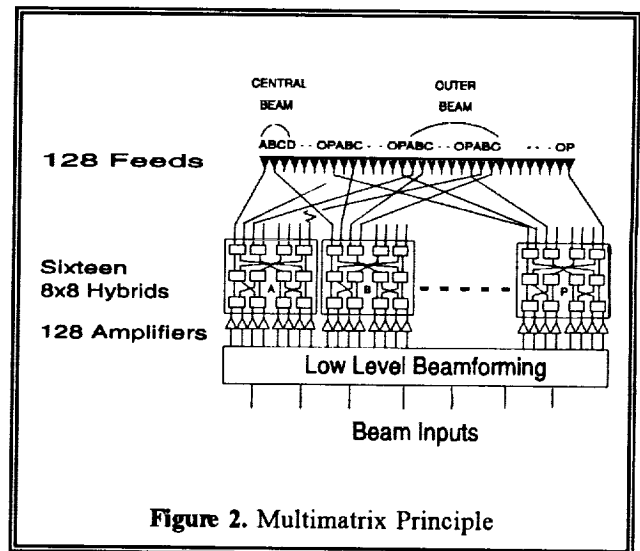

Figure 2. Multimatrix Principle

Since thousands of channels are transmitted into around 85 beams for land coverage, optimised complex excitations (with a limited dynamic range to simplify beamforming) can be used, as each amplifier contributes to many beams and, therefore, its power is averaged. With a 10dB range, central beams use 3 to 7 feeds and outer ones up to 16. The cross-over levels between beams vary from -3dB (centre) to -1.3dB (edge). Computed contours of typical beams over the Earth's surface with these excitations are shown in Figure 3 for the antennas of Figure 1. A scaled version of this antenna (6.5m×9m),

operating in the beam synthesis mode, is proposed for the receive function.

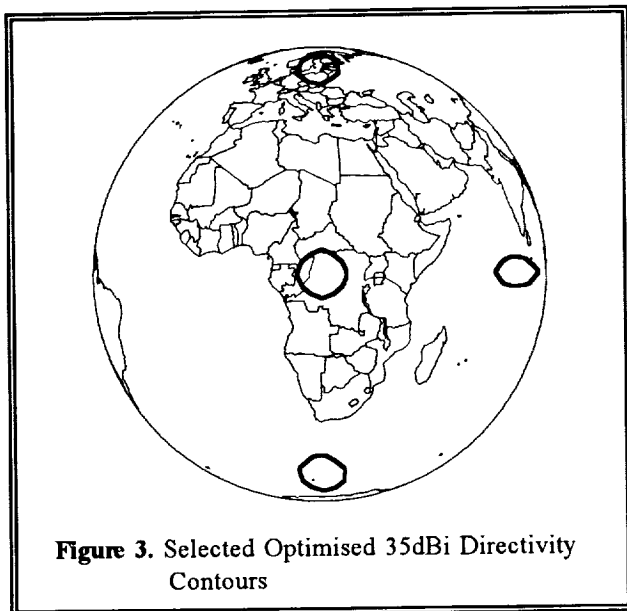

Figure 3. Selected Optimised 35dBi Directivity Contours

With digital beamforming it is envisaged to generate a large number of repositionable beams crossing over around 1dB.

4. CANDIDATE PAYLOAD

Previously performed trade-offs led to the conclusion that in the case of payloads with a large number of beams (as is inevitably the case for global personal communications) in conjunction with the requirement to use many feeds per beam, narrowband digital beamforming combined with CFT or all-digital multiplexing has a significant mass advantage over other techniques based on a SAW filter banks and analogue beamforming. Therefore, the candidate payload is based on the repeater design with digital beamforming and CFT processing. The preferred antenna option is beam synthesis on receive and the semi-active multimatrix on transmit, because it avoids the use of different amplifiers in the transmit mode and implies a minimum number of feeds per beam.

Figure 4 shows a basic block diagram of the candidate payload, while the main payload budgets are shown in Table 5. It should be noted that the RF power has been calculated for the most disadvantaged users - those in the beams with lowest peak gain at the edge of coverage. For users closer to the centre of the satellite coverage (i.e. near the sub-satellite point) there is a power advantage resulting from the lower path loss (approximately 1dB) and higher peak antenna gain. The actual benefit in total RF power requirement is directly dependant on the distribution of the users within the satellite coverage and has not been evaluated in this paper.

	Mass [Kg]	Power [W]
C-band sub-system	12.2	306.0
<i>receiver</i>	1.6	6.0
<i>HPA</i>	5.9	300.0
<i>output MUX</i>	1.8	
<i>receive antenna</i>	1.1	
<i>transmit antenna</i>	1.8	
power supply unit	25.0	250.0
FWD and RTN processors	107.1	381.0
S-band SSPA ($\eta=33\%$)	84.0	2744.0
low noise amplifiers (L-band)	33.4	211.0
S-band Tx antenna	95.0	
L-band Rx antenna	120.0	
TTC interface unit	4.0	
cables	43.8	
harness	30.0	
Total	554	3890

It has been assumed for the mass budgets that most of the critical elements (all feeder link components, mobile link SSPAs and LNAs, and digital circuitry) are 2 for 1 redundant, the notable exception being the feed element chains within the processors (DACs and the analogue output components, including the CFTs). As the antennas are essentially focus fed, graceful degradation is not acceptable. A satisfactory reliability estimate was obtained by securing 3 additional redundant chains for every group of 11 chains (14 for 11 redundancy).

The assumed digital technology is radiation hardened CMOS (0.8 μ m), which is the selected option for a 1998-2000 launch.

Although FDMA access scheme has been taken for this example, this type of payload design is well suited for narrowband TDMA and would lead to similar, if not lower, mass and power figures, due to the fact that the processing load would be slightly lower in this case.

CONCLUSIONS

ESA is actively pursuing different space segment options for the provision of voice and data communications to users equipped with mobile, portable and hand-held terminals, at L and S-bands.

In particular a Geostationary (GSO) satellite option is attractive (compared to MEO or LEO satellite constellations), because of the low (3 to 4) number of satellites involved, the technological heritage and the relative simplicity of the ground segment and network management.

This paper has described possible GSO payload architectures, including L and S-band antennas and repeater sub-systems. For the mobile link antennas, direct

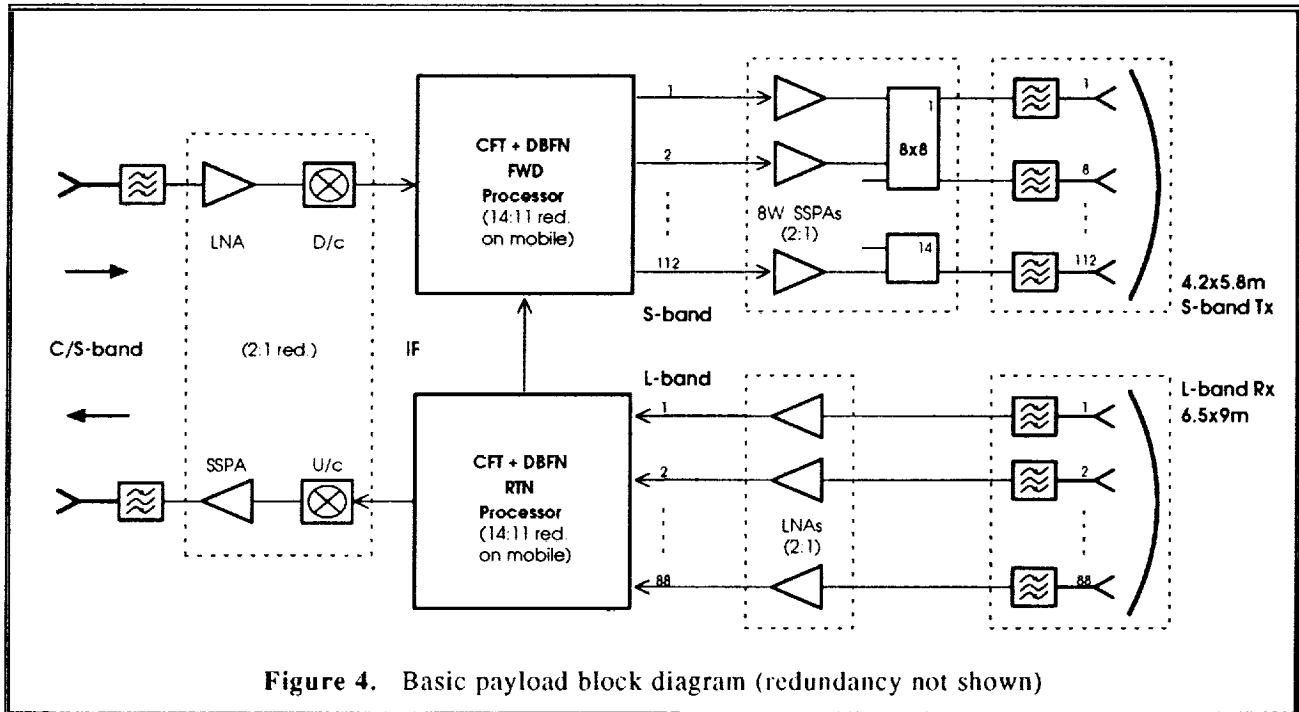

Figure 4. Basic payload block diagram (redundancy not shown)

radiating arrays and focusing multifeed reflector antennas have been evaluated. Concerning the payload processor, which performs the routing, switching and beamforming functions, analogue and digital implementations involving SAW filters, CFTs and digital beamforming technologies have been evaluated and compared.

Finally, a candidate payload is described and its total mass and DC power consumption are calculated for a total capacity of 5000 duplex voice circuits.

Key technologies that are required to be developed to space qualification are CFT-based channel transmultiplexing, digital beamforming, high efficiency medium-power S-band SSPAs, highly integrated very low-noise L-band LNAs and large (6 to 10 metres) unfurlable L and S-band antennas.

ACKNOWLEDGEMENTS

The authors are grateful to the many colleagues, in industry and in ESA-ESTEC, who have supported this work, and in particular BAe Space Systems, for their help with computations.

REFERENCES

- [1] A. Zaghloul, F. Assal, B. Hutchinson, E. Jurkiewicz, *Satellite Communications to Hand-Held Terminals from Geostationary Orbit*, 9th International Conference on Digital Satellite Communications, Copenhagen, May 1992.
- [2] J. Benedicto, J. Fortuny, P. Rastrilla, *MAGSS-14: A Medium-Altitude Global Mobile Satellite System for Personal Communications at L-band*, ESA Journal 92, Vol.16.
- [3] G. Solari, R. Viola, *M-HEO: The Optimal Satellite System for the Most Highly Populated Regions of the Northern Hemisphere*, ESA Bulletin, May 1992, No. 70.
- [4] A. Craig et al., *Applicability of Different On-Board Routing and Processing Techniques Applied to a Mobile Satellite System*, 3rd International Mobile Satellite Conference and Exhibition, Pasadena, June 1993.
- [5] Le Normand et al., *A versatile array fed reflector antenna*, 1988 IEEE AP-S International Symposium Digest.
- [6] R. Lo Forti, T. Jones, A. Roederer, *Performance evaluation of a near field fed double curvature reflector*, 1990 IEEE AP-S International Symposium Digest.
- [7] S. Stirland, J. Joshi, A. Roederer, R. Graham, *Active and semi-active reflector antennas*, ESA Workshop on Advanced Beamforming Networks for Space, 1991.
- [8] A. Roederer, *Semi-active satellite antennas*, invited paper, Proc. JINA '92.