

N 9 4 - 2 2 8 1 3

Performance of the Unique-Word-Reverse-Modulation Type Demodulator for Mobile Satellite Communications

Tomohiro Dohi, Kazumasa Nitta, Takashi Ueda

NTT Mobile Communications Network Inc.

1-2356 Take, Yokosuka-shi, 238-03 Japan

Phone : +81 468 59 3462 Fax : +81 468 57 7909

ABSTRACT

This paper proposes a new type of coherent demodulator, the unique-word(UW)-reverse-modulation type demodulator, for burst signal controlled by voice operated transmitter (VOX) in mobile satellite communication channels. The demodulator has three individual circuits: a pre-detection signal combiner, a pre-detection UW detector and a UW-reverse-modulation type demodulator. The pre-detection signal combiner combines signal sequences received by two antennas and improves bit energy-to-noise power density ratio (E_b/N_0) 2.5 dB to yield 10^{-3} average bit error rate (BER) when carrier power-to-multipath power ratio (CMR) is 15 dB. The pre-detection UW detector improves UW detection probability when the frequency offset is large. The UW-reverse-modulation type demodulator realizes a maximum pull-in frequency of 3.9 kHz, the pull-in time is 2.4 seconds and frequency error is less than 20 Hz. The performances of this demodulator are confirmed through computer simulations and its effect is clarified in real-time experiments at a bit rate of 16.8 kbps using digital signal processor (DSP).

INTRODUCTION

Practical mobile satellite communication systems are being developed in many countries. In Japan, the characteristics of mobile satellite channels were obtained from a field test of experimental mobile satellite systems (EMSS) using the Engineering Test Satellite V (ETS-V)[1]. The results confirmed that the channels of the mobile satellite communication system are high CMR Rician fading channels. Meanwhile, since satellite communication channels are power-limited, forward error correction (FEC) must be employed to improve BER in

low carrier power-to-noise power ratio (CNR) channels.

To improve the received E_b/N_0 , signal combination should be powerful. Conventionally, two types of signal combination scheme are well-known. One is the post-detection signal combination scheme [2], and the other is the pre-detection signal combination scheme [3]. When the post-detection scheme is employed, each demodulator must operate stably before the received E_b/N_0 is improved. On the other hand, when the pre-detection scheme is employed, a demodulator can operate stably after the received E_b/N_0 is improved. Since the conventional pre-detection scheme is a feed-back type, its ability to track variations in channel state is inferior. Therefore, this paper proposes a pre-detection signal combination scheme with a feed-forward loop. Its tracking ability is very high.

In mobile satellite communication channels, rapid UW detection after shadowing is required. Since the received UW is used for demodulation in the proposed scheme, UW detection must be carried out ahead of demodulation. Furthermore, the range of pull-in frequency is expanded 30 times that of the conventional scheme, because the UW detector detects correlation value from the phase difference of received signals.

In mobile satellite communications, carrier frequency offset due to Doppler shift occurs when the mobile station moves at high speed. When the transmission rate is assumed to be 16.8 kbps, the frequency error must be less than several tens Hz to prevent carrier slip. To keep this frequency error, highly precise automatic frequency control (AFC) is required. This paper proposes a UW-reverse-modulation type demodulator including AFC circuit. In this demodulator, a reverse modulated signal sequence is used for estimating the carrier fre-

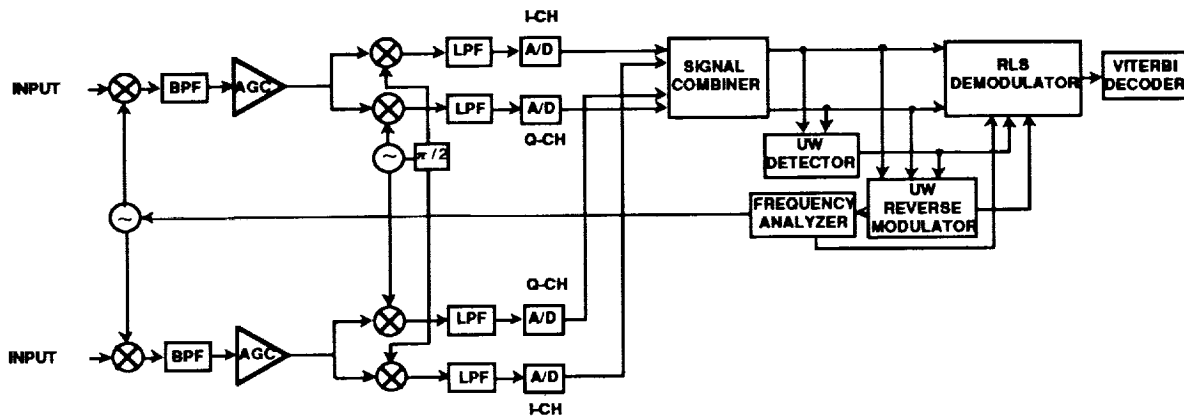

Figure 1 Configuration of the Receiver

quency offset by fast Fourier transformation (FFT). Consequently, short pull-in time (2.4 seconds), high precision (frequency error is 20 Hz) and wide pull-in range (about 4 kHz) are realized using this scheme.

In this paper, configuration and characteristics of the mobile terminal receiver are described in detail.

CONFIGURATION

Configuration of the receiver is shown in Figure 1. The receiver consists of RF/IF circuit, pre-detection signal combiner, pre-detection UW detector, UW-reverse-modulation type demodulator including AFC circuit and Viterbi decoder. The receiver has two RF/IF circuits. Both RF/IF circuits consist of a band pass filter (BPF), automatic gain control (AGC) circuit and low pass filters (LPF). The RF/IF circuit down-converts the received RF signal sequence into the IF band, and the IF signal sequence is down-converted into the baseband. In the signal combiner, each analog signal sequence is converted into a 12 bit digital signal sequence with identical timing. Each branch's signal sequence is combined to improve the received E_b/N_0 . The combined signal is led to the UW detector. The UW detector consists of two correlators. These correlators are switched according to the degree of phase rotation. The frame is reconstructed in the UW detector and sent to the demodulator. The recursive least squares (RLS) algorithm is employed in the demodulator. In the AFC circuits, the reverse modulated signal sequence is used for estimating the carrier frequency offset by FFT. When the carrier frequency offset is larger than 1 kHz, the output from FFT is used as the control voltage of the voltage-controlled oscillator (VCO). On the other hand,

the output is multiplied by the received baseband signal sequence when the carrier frequency offset is less than 1 kHz. Consequently, carrier offset component is removed from received signal sequence used in the demodulator. The constraint length is 7 ($k=7$), the coding rate is $1/2$ ($R=1/2$), and 4 bit soft decision is employed for Viterbi decoder. The signal combiner, UW detector, UW reverse-modulation-type demodulator including AFC circuit and Viterbi decoder were implemented on DSP.

PRE-DETECTION SIGNAL COMBINER

Configuration and Principle

In the pre-detection signal combiner, the received E_b/N_0 is theoretically improved 3 dB, because the direct wave's signal amplitude is combined and noise power is combined. Configuration of the pre-detection signal combiner is illustrated in Figure 2. Signal sequences are received by two antennas and converted into baseband analog signal sequences by quadrature detection in the RF/IF circuits which consist of frequency converters, BPFs and AGC amplifiers. These signal sequences are A/D converted with identical timing, and one signal sequence is multiplied by the other signal sequence's complex conjugate. Since this product is derived from A/D converted signals with identical timing, influence of modulation upon phase is removed from the product. The product means that noise and fading components are added to the phase difference of the 2 received direct waves at each branch. Noise and fading components is removed from the signal by averaging, and obtained phase difference is multiplied by one signal sequence and combined with the

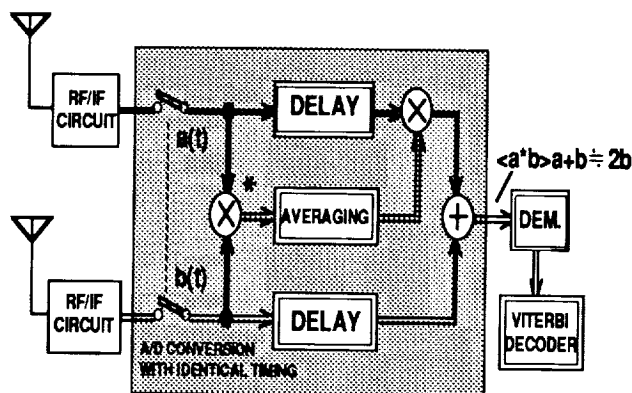

Figure 2 Configuration of Pre-detection Signal Combiner

other signal sequence. In this operation, it doesn't matter that the clock used for A/D conversion is not synchronized to the transmitted signal if the clock rate is faster than transmission symbol rate. Clock synchronization is established in the demodulator after combination.

The Number of Averaging Symbols

To achieve accurate phase combination, noise and fading component must be removed from the received signal by averaging. Required number of averaging symbols was clarified through computer simulations. In these simulations, it is assumed that CMR is 15 and 20 dB, and that E_b/N_0 is 0 dB. The relation between the number of averaging symbols and combination gain is shown in Figure 3. When CMR is 15 dB, the degradation of combination gain with 30 averaging symbols is less than 0.5 dB compared to the theoretical value (3 dB). When CMR is 20 dB, it is 0.3 dB. Therefore, 30 averaging symbols are enough to realize high combination gain. The improvement in BER performance with signal combination is confirmed through the real-time experiments described later.

UW DETECTOR

In the demodulator, UW detection must be carried out ahead of demodulation, because the received UW is used for demodulation. To realize compact and low cost mobile terminals, temperature-compensated crystal oscillators (TCXO) that do not utilize thermostatic ovens are required. TCXO stability is within 1 ppm. When transmission bit rate is assumed to be 16.8 kbps in the S-band (2.6 / 2.5 GHz), it is

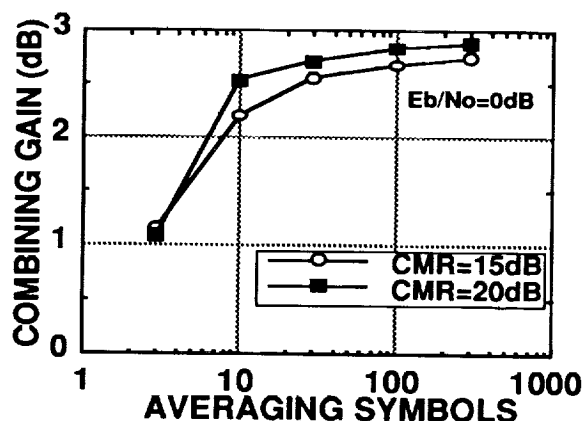

Figure 3 Relation between the Number of Symbols and Combining Gain

required that frame synchronization must be kept when $\Delta f T$ (Δf : frequency offset) is less than 0.2. If frequency offset is small, the probability of UW detection with the conventional scheme is good. However, if frequency offset is large, the probability is degraded significantly. Therefore, a new UW detection scheme is required to satisfy this requirement of frame synchronization. Configuration of the proposed UW detector is illustrated in Figure 4. This detector has a phase rotation detector and selects one of two correlation detectors according to the degree of phase rotation. One correlation detector is a conventional type. In this detector, the input signal sequence is memorized in delay circuit with taps and multiplied by the complex conjugate of the UW pattern. The products are integrated, and each component of integration is squared and added. This yields the correlation value. In the other detector, the input signal sequence is detected differentially at first. Detected sequence is memorized in delay cir-

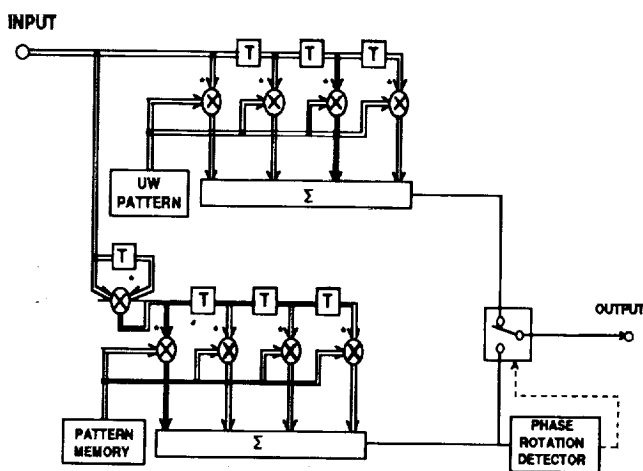

Figure 4 Configuration of UW Detector

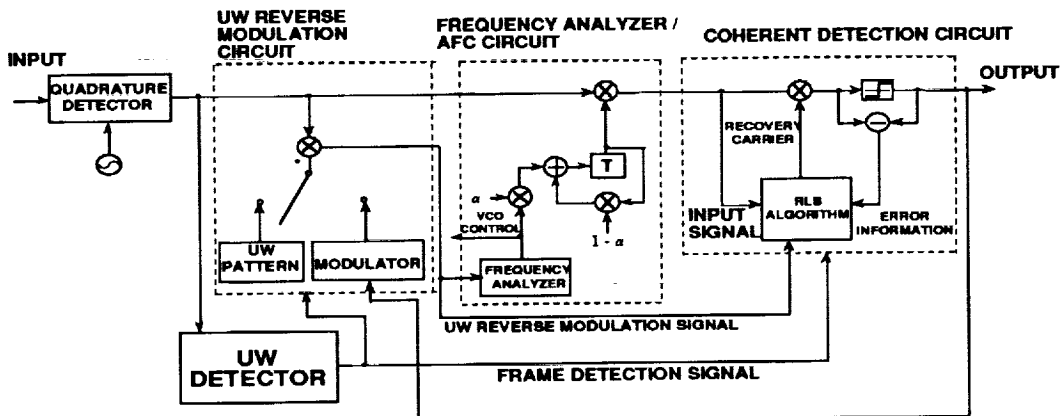

Figure 5 Configuration of UW-Reverse-Modulation Type Demodulator

uits and multiplied by the complex conjugate of the difference of adjacent symbols in the UW pattern memorized in pattern memory. Remaining behavior are the same as those of conventional detector. Absolute ratio of real part to imaginary part of integration is used to detect the degree of phase rotation. When the degree of phase rotation is small, the real part is much larger than the imaginary part, and the conventional correlator is selected. When the real part is not much larger than the imaginary part, the new correlator is selected. Performance of the UW detector is described in the section on experimental results.

UW-REVERSE-MODULATION TYPE DEMODULATOR

Configuration and Principle

In the S-band, when TCXO stability is 1 ppm, maximum frequency offset is considered to be 2.6 kHz. When the mobile station moves

at 100 km/h and the elevation angle is 40 degrees, the frequency offset caused by Doppler shift is 180 Hz. If the transmission rate is assumed to be 16.8 kbps, the frequency error must be less than 20 Hz to prevent carrier slip. On the other hand, since this demodulator is applied for burst signal controlled by VOX, rapid pull-in time is required. Under these conditions, frequency control by AFC is required to operate the receiver normally. As above-mentioned, the maximum pull-in frequency is assumed to be 3 kHz. Furthermore, it is assumed that frequency error is 20 Hz, and pull-in time is 3 seconds. The proposed UW-reverse-modulation type demodulator is shown in Figure 5. In the AFC circuit, the reverse modulated signal sequence is used for estimating frequency offset by applying FFT. The reverse modulated signal sequence consists of a UW reverse modulation signal sequence and a reverse modulated information signal sequence. Received baseband signal sequence is multiplied by the complex conjugate of the UW pattern. The product

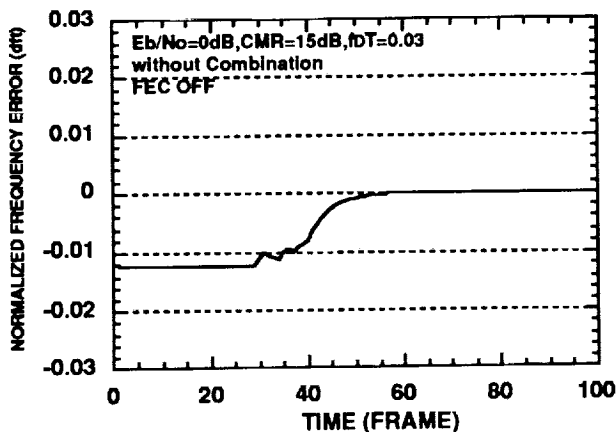

Figure 6 Pull-in Performance

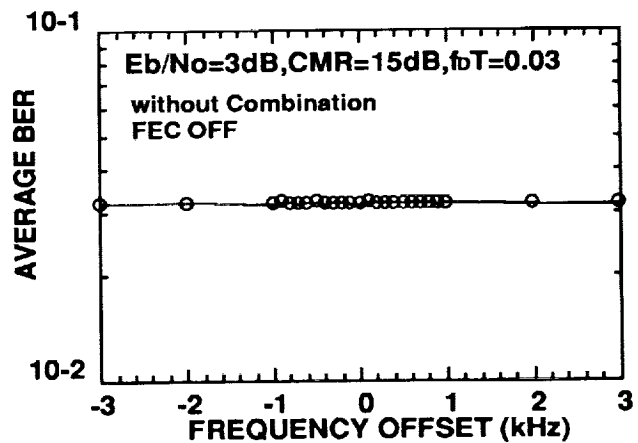

Figure 7 Pull-In Frequency Performance

sequence is the UW reverse modulation signal sequence. The information data sequence following the UW signal is modulated after demodulation. Received baseband signal sequence following the UW signal is multiplied by the complex conjugate of the modulated signal sequence. The product sequence is the reverse modulated information signal sequence. The result of estimating is used as the VCO control voltage when the carrier frequency offset is larger than 1 kHz. When carrier frequency offset is less than 1 kHz, after averaging the results of estimating, the result is multiplied by the received baseband signal sequence, and the carrier offset component is removed from the received signal sequence.

Characteristics of the proposed AFC

AFC performance was clarified through computer simulations. In these simulations, ideal frame and clock synchronization was assumed. It was assumed that the transmission bit rate is 16.8 kbps, UW length is 64 bit and information bit length is 608 bit. The relation between pull-in time and normalized frequency error (frequency error / transmission rate) is shown in Figure 6. In this figure, the horizontal axis indicates the number of frames, that is, time, and the vertical axis indicates the normalized frequency error after pull-in. Pull-in time is 60 frames (2.4 seconds), and this satisfies the requirement given above. Normalized frequency error after pull-in is 0, which definitely satisfies the requirement. The relation between frequency offset and average BER is shown in Figure 7. Average BER is not degraded if the frequency offset is less than 3.9 kHz. Average BER will be degraded due to the bandwidth limitation of the IF filter if experimentally measured.

EXPERIMENTAL RESULTS

The above-mentioned techniques were clarified in real-time experiments. Experimental parameters are shown in Table 1. According to results of the EMSS experiment, CMR was assumed to be 15 dB. Each frame consists of a 64 bit UW and 608 bit of information data. A 16.8 kbps, nine-stage pseudo noise (PN) sequence is the transmitted data. A five-stage PN sequence is the UW data. After a $\pi/4$ -shift quadrature phase shift keying (QPSK) signal

(roll off factor $\alpha = 0.5$) is generated in the baseband, it is modulated and transmitted over a communication channel. Rician fading is generated by a fading simulator. RF/IF circuit is composed of analog devices. Signal combiner, UW detector, UW-reverse-modulation type demodulator including AFC and Viterbi decoding are implemented as DSP.

The average BER performances are shown in Figure 8. There are 4 kinds of average measured BER performances plotted in Figure 8. Solid curve indicates theoretical performance without FEC or signal combination. Points indicate measured values without the proposed techniques, measured values with FEC, measured values with signal combination and measured values with both FEC and signal combination. The degradation of average BER performance of the demodulator without signal combination or Viterbi decoding compared to the theoretical one is less than 0.5 dB. Therefore, it can be said that the demodulator is very precise. When using signal combination and Viterbi decoding, average BER performance is improved about 3 dB in terms of E_b/N_0 to yield $BER = 10^{-3}$ compared with the one of using Viterbi decoding only.

Table 1 Experimental Parameters

Modulation	$\pi/4$ -QPSK ($\alpha=0.5$)
Demodulation	Coherent Detection
Frame Length	40ms
UW	64bit
Data	608bit
Bit Rate	16.8kb/s
FEC	$k=7, R=1/2$ Convolutional Coding / Soft Decision Viterbi Decoding
CMR	15dB
f _{off}	2.4×10^{-3}

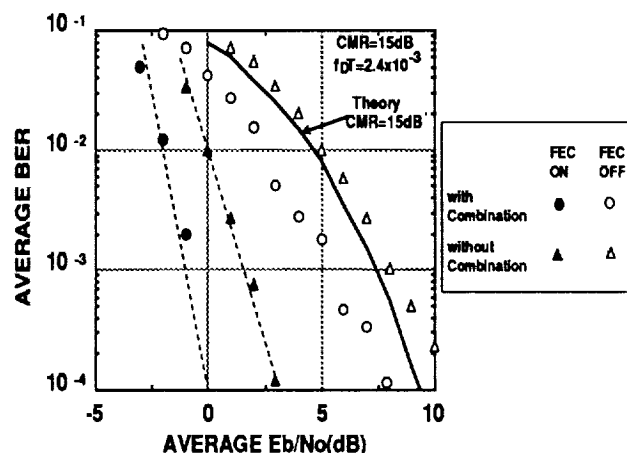

Figure 8 Average BER Performances

The relation between frequency offset and UW miss detection probability of the proposed UW detection scheme is shown in Figure 9. Since it is difficult to measure the UW miss detection probability when E_b/N_0 is assumed to be 0 dB, E_b/N_0 is assumed to be -3 dB and -2 dB. When the transmission bit rate is 16.8 kbps and absolute value of frequency offset is more than 100 Hz, UW miss detection probability of the proposed scheme is superior. When absolute value of frequency offset is less than 100 Hz, UW miss detection probability of the conventional scheme is better than that of the proposed scheme. The conventional scheme is poor with large frequency offset. Consequently, when the threshold of selection is assumed to be 100 Hz, best UW detection performance is obtained.

The relation between frequency offset and average BER at 3 dB E_b/N_0 is shown in Figure 10. When the frequency offset is 2 kHz, BER performance degradation is only 40 % compared to the no frequency offset case. When the frequency offset is 3 kHz, BER performance degrades because of the IF filter.

CONCLUSION

Configuration and performances of a UW-reverse-modulation type demodulator for mobile satellite communication systems is presented. Pre-detection signal combiner combines two branch signal sequences ahead of detection to allow accurate behavior in the low CNR condition. Consequently, the received E_b/N_0 is improved 2.5 dB. Frame synchronization is established before demodulation to realize rapid synchronization. Proposed UW detector does not degrade UW detection probability even if the frequency offset is large. This new demodulator realizes a maximum pull-in frequency of 3.9 kHz, pull-in time is 2.4 seconds and frequency error is less than 20 Hz. Application of these techniques enables the receiver to operate normally in satellite communication channels.

ACKNOWLEDGEMENT

The authors wish to thank Mr. Kuramoto, Mr. Mishima, Mr. Murota and Mr. Hagiwara for their helpful guidance and encouragement.

REFERENCES

[1] T. Sakai and T. Dohi, "Bit Error Rate Characteristics on Mobile Satellite Communication

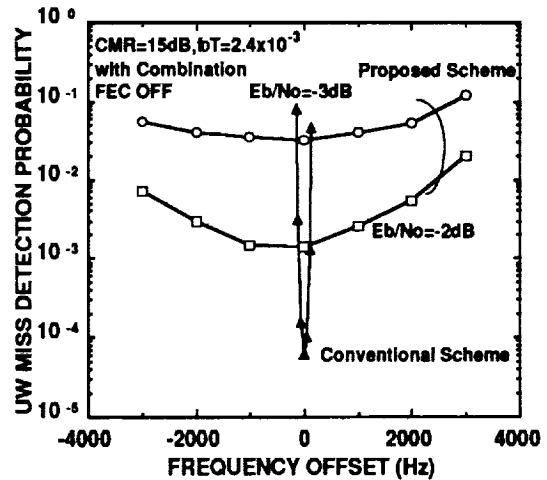

Figure 9 Relation between Frequency Offset and UW Miss Detection Probability

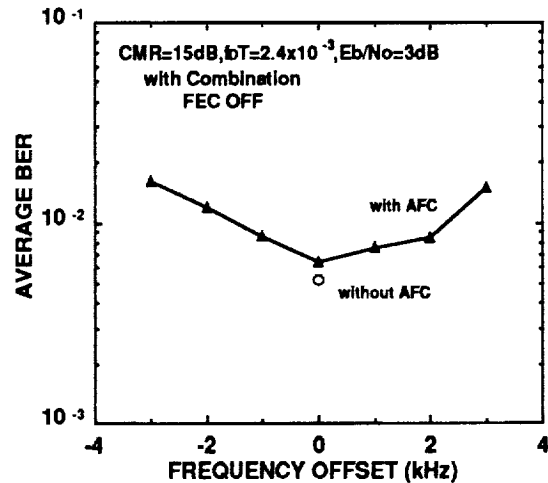

Figure 10 Pull-In Frequency Performance

Channels", *Trans. IEICE*, J72-B-II, pp. 285-289, July 1989.

[2] S. Hara and N. Morinaga, "Post-Detection Combining Diversity Improvement of 4-Phase DPSK System in Mobile Satellite Communications", *Trans. IEICE*, J72-B-II, pp. 304-309, July 1989.

[3] J. Granlund, "Topics in the Design of Antenna for Scatter", *Technical Report 135*, Lincoln Laboratory, MIT, November 1956.