

TDA Progress Report 42-115

November 15, 1993

198552  
P-15  
N94-23258

# New Approaches for Tracking Earth Orbiters Using Modified GPS Ground Receivers

S. M. Lichten, L. E. Young, S. Nandi, B. J. Haines, and C. E. Dunn  
Tracking Systems and Applications Section

C. D. Edwards  
TDA Technology Development Section

*A Global Positioning System (GPS) flight receiver provides a means to precisely determine orbits for satellites in low-to-moderate altitude orbits. Above a 5000-km altitude, however, relatively few GPS satellites are visible. New approaches to orbit determination for satellites at higher altitudes could reduce DSN antenna time needed to provide navigation and orbit determination support to future missions. Modification of GPS ground receivers enables a beacon from the orbiter to be tracked simultaneously with GPS data. The orbit accuracy expected from this GPS-like tracking (GLT) technique is expected to be in the range of a few meters or better for altitudes up to 100,000 km with a global ground network. For geosynchronous satellites, however, there are unique challenges due to geometrical limitations and to the lack of strong dynamical signature in tracking data. We examine two approaches for tracking the Tracking and Data Relay Satellite System (TDRSS) geostationary orbiters. One uses GLT with a global network; the other relies on a small "connected element" ground network with a distributed clock for short-baseline differential carrier phase ( $SB\Delta\Phi$ ). We describe an experiment planned for late 1993, which will combine aspects of both GLT and  $SB\Delta\Phi$ , to demonstrate a new approach for tracking the Tracking and Data Relay Satellites (TDRSs) that offers a number of operationally convenient and attractive features. The TDRS demonstration will be in effect a proof-of-concept experiment for a new approach to tracking spacecraft which could be applied more generally to deep-space as well as near-Earth regimes.*

## I. Introduction

The Global Positioning System (GPS) has ushered in a new era for satellite tracking and precise orbit determination. The TOPEX/POSEIDON GPS precise orbit-determination demonstration has shown that sub-10-cm

orbit accuracy is attainable for a low Earth orbiter equipped with a high-quality GPS flight receiver [1]. The key to high-accuracy positioning with a GPS flight receiver is the simultaneous common view of multiple GPS satellites as seen from the orbiting receiver and a network of ground receivers. As the altitude of the Earth orbiter car-

rying the GPS flight receiver increases, however, the number of GPS satellites in view decreases. Above a 5000-km altitude, typically less than four GPS satellites are simultaneously in view from the Earth orbiter [2]. This situation can be helped somewhat by designing the flight instrument so that GPS satellites can be tracked from the opposite side of the Earth—the “down-looking differential GPS” approach [2,3]. This introduces some additional complications, however, such as greater space loss and weaker GPS signals, higher atmospheric distortion from the near-grazing Earth geometry, contamination of the signal with radiation from the Earth, and complications regarding the placement of the GPS antenna on the satellite.

Orbit determination for Earth orbiters carrying GPS flight receivers above a 5000-km altitude has also been studied for highly elliptical orbits [4]. Decimeter-quality performance can in principle be achieved provided that perigee is below 10,000 km. However, for satellites at much higher altitudes, such as geosynchronous or higher, the GPS visibility for either the upward-looking TOPEX/POSEIDON-style flight instrument or a down-looking instrument is poor.

New techniques using GPS technology for tracking satellites in high Earth and elliptical orbits are being studied in the DSN Advanced Systems Program. One approach dispenses with the GPS flight receiver, employing instead a simple beacon aboard the satellite to transmit a signal which can be tracked along with the GPS signals by the ground GPS receivers. This GPS-like tracking (GLT) beacon approach (also sometimes called “inverted GPS” since the differential positioning of the user spacecraft is made relative to the GPS satellites rather than to the ground stations) has been studied in a preliminary way by Wu et al. [3] and Haines et al. [5]. Another approach would use short-baseline differential carrier phase ( $S\Delta\Phi$ ), which might be particularly convenient for tracking a geosynchronous orbiter [6]. Both GLT and  $S\Delta\Phi$  are operationally attractive because they are amenable to automated processing schemes and could provide spacecraft tracking and navigation without large DSN antenna time.

As described in [3] and [5], for GLT a small number of modified GPS ground receivers would be distributed in a global network for tracking a GPS-like beacon on the high Earth orbiter.<sup>1</sup> The beacon would, preferably, transmit a simple set of ranging tones, which would be detected in GPS ground receivers modified so that they

<sup>1</sup> It is assumed that placing an actual GPS transmitter on a NASA satellite would be impractical for a number of reasons. On the other hand, a *GPS-like* (or GPS-compatible) beacon would not be difficult.

simultaneously track the user satellite along with GPS satellites. The result would be a precise differential orbit-determination capability for the high Earth orbiter. In contrast, the  $S\Delta\Phi$  technique utilizes short (approximately 100-km) baselines around a central site, relying primarily on carrier phase observables (although some ranging information is required for geosynchronous tracking). As originally proposed by Nandi et al. [6], the  $S\Delta\Phi$  approach utilizes a single distributed clock for the local network of ground receivers. The distributed clock could be provided, for example, by fiber-optic links. Although the overall accuracy with the  $S\Delta\Phi$  technique is expected to be somewhat degraded by the geometrical limitations imposed by the short baselines (relative to the global network), there is considerable operational convenience—particularly for near-real-time operation.

In this article, we focus on the  $S\Delta\Phi$  and GLT approaches. Analyses will be presented for Earth orbiters at altitudes from 40,000–100,000 km, where we show that orbit accuracy of a few meters could be achieved. We describe a demonstration experiment with Tracking and Data Relay Satellite System (TDRSS) geosynchronous orbiters that will take place late in 1993. In the TDRSS experiment, the ground network will be restricted by the limited Tracking and Data Relay Satellite (TDRS) ground footprint, so we plan to use a blend of  $S\Delta\Phi$  and GLT to demonstrate a proof of concept for this unique application of GPS technology for tracking satellites at high altitude. For the TDRS tracking demonstration, the goal is to provide a near-real-time capability for tracking to an accuracy of several tens of meters.

## II. Review of Differential GPS Tracking Fundamentals

The GPS constellation is designed so that typically 6 to 10 navigation satellites can be tracked above 5 deg elevation from any ground site. When complete, the constellation will include 24 operational satellites. The GPS satellites transmit carrier signals at 1.228 and 1.575 GHz (L-band), which are modulated by a pseudorandom noise code, the P-code (precision code), at 10.23 MHz. Two frequencies are provided so that ionospheric signal delays can be calibrated. A second code, the C/A (clear acquisition) code, is somewhat noisier than the P-code due to its lower frequency at 1.023 MHz and the lack of dual-band ionospheric correction (see Fig. 1).

The GPS codes include a navigation message with GPS clock and orbit information which can be utilized for real-time point positioning by users equipped with GPS receivers. GPS pseudorange to four satellites determines

three position coordinates plus the user clock offset from GPS time. The term "pseudorange" is used since the range calculation is based on the difference between the transmit and receive times and will include any offset between the transmitter and receiver clocks. With the P-code, user positions can be determined in a point positioning mode in near-real time to about 10 m. In normal operation, the Department of Defense turns on selective availability (SA) for most GPS satellites. SA introduces what can appear to be a clock dither and alterations to the broadcast ephemeris. Certain authorized users will be equipped with keys to correct for these effects, but other users will see transmitter clock variations of the order of 30–50 m with the broadcast ephemeris degraded to a similar level of accuracy. Few scientific and nonmilitary GPS users will be equipped with the keys for SA. Simultaneous GPS tracking from multiple receivers can differentially eliminate GPS and receiver clock offsets, including the apparent clock dithering from SA. Because the broadcast ephemeris provides orbit information at the level of 5–10 m (which could degrade to 50–100 m with implementation of another component of SA), for the highest precision, the user must estimate and improve the GPS orbits *and* use differential GPS techniques, as shown in Fig. 2. While Fig. 2 shows how transmitter and receiver clock offsets can be differentially eliminated, there are distinct advantages to explicitly estimating clocks in a Kalman filter. One advantage is that the pseudorange measurements provide a natural filter constraint to improve the determination of the clock offsets and phase biases; another is that introduction of data correlations through explicit differencing is avoided.

The primary data type for highest precision in non-real-time GPS applications is the carrier phase, which can be tracked with sub-centimeter precision in modern GPS receivers. The carrier phase, continuously tracked over hours, provides a precise time history of biased range (also referred to as "range change") which can be used to obtain precise orbit solutions (Fig. 2). The GPS carrier phase is ambiguous by some integer multiple of carrier wavelengths, but the carrier measures range change to sub-centimeter precision. Pseudorange data, even though typically 1–2 orders of magnitude noisier than phase data, are still useful, since they can be used in a Kalman-type filter to constrain the clocks and carrier phase integer ambiguities, which in general must be estimated. It is the simultaneous tracking from multiple receivers that allows for estimation of clock offsets to very high precision. After 12 hr of tracking, sub-meter GPS orbit accuracy can be achieved [7] and, more recently, with data arcs of 30 hr, GPS orbits are determined daily at JPL with a precision of 30–50 cm [8]. Figure 3 shows how GPS orbit quality has been assessed recently, with slightly overlapping 30-hr arcs.

Antispoofing (AS) may be routinely activated once the GPS constellation is fully operational. AS encrypts P-code, which can then be observed only in receivers with decryption modules; ordinary receivers can receive only the noisier C/A-L1 pseudorange measurements and L1 carrier phase. This would ordinarily severely limit positioning accuracy with GPS for users without authorization to use security modules in ground receivers. However, a number of receivers can produce "codeless" observables, resulting in high-quality carrier phase data with ionospheric correction. Some receivers can produce moderately precise codeless pseudorange as well. The codeless techniques include cross-correlation and squaring algorithms that enable precise observables, corrected for the ionosphere without requiring classified information, to be obtained. The results in Fig. 3 were obtained with receivers which have a codeless capability; however, since AS was actually off during those tracking sessions, the results were determined with P-code observables.

### III. Differential GPS Tracking With an Orbiting Receiver

Figure 4 shows the geometry for differential GPS tracking with an orbiting flight receiver. For low Earth orbiters at altitudes of a few thousand kilometers or less, good visibility of GPS satellites is provided with an upward-looking flight instrument. An example is the TOPEX/POSEIDON satellite, for which sub-10-cm orbit accuracy has been demonstrated [1]. However, as the altitude increases above 3000 km, GPS visibility falls off dramatically (Fig. 5). Down-looking GPS, where the flight instrument looks down past the Earth's limb to track GPS satellites from the opposite side, provides more GPS measurements for altitudes between a few thousand and 10,000 km. However, above 10,000 km, there are typically less than two GPS satellites in view, making high-precision GPS differential positioning more difficult.

One possibility for a down-looking differential GPS application would be to equip the TDRSS geosynchronous satellites with GPS flight receivers to provide orbit determination for TDRSSs. This scenario was studied through a series of covariance analyses [3,5] as part of an assessment for alternative tracking techniques for TDRSSs. Those studies, utilizing a square-root information Kalman-type filter, showed that a geosynchronous TDRS carrying a hypothetical GPS receiver could in principle routinely achieve sub-40-m orbit accuracy less than 4 hr after a maneuver only if the flight instrument carried decryption for SA, which would require uploads of classified information. Without removal of SA, 4 hr after a maneuver the

predicted orbit errors were much higher—several hundred meters, reducing to 60 m after 24 hr. While such performance might be acceptable to some geosynchronous users, the goal of the studies was to identify for TDRSS new technologies which could operationally and conveniently support a 50-m requirement within a few hours after a maneuver. Thus, SA correction would be required, and this was considered to be inconvenient from an operational point of view.

An alternative approach for satellites above 5000 km is to use a GPS-like beacon on board for tracking from a GPS ground network. The advantage of this GLT option is illustrated by the counts shown in Fig. 5, where 10 ground stations are assumed to be evenly distributed around the globe. The key to exploiting the precision inherent in GPS tracking in this case is to use the same GPS ground receivers for tracking the user satellite simultaneously with multiple GPS satellites. The tracking performance might be comparable to that expected from having a hypothetical GPS satellite moved from the usual 20,200-km-altitude orbit up to geosynchronous altitude at 37,000 km, Fig. 6(a). This option is discussed in the following section.

#### IV. GPS-Like Tracking for TDRS

What performance would one expect from a hypothetical GPS satellite at geosynchronous altitude, such as in Fig. 6(a)? As a starting point, we can look at present-day GPS tracking accuracy (Fig. 3), routinely obtained at JPL with the GPS Inferred Positioning System (GIPSY)-Orbit Analysis and Simulation Software (OASIS), a prototype for a future operational system. The GPS tracking data are processed with a turnaround of 3–10 days, but this is limited primarily by data transmittal delays from some of the approximately 30 globally distributed tracking sites. Since some of the sites routinely transmit data several minutes after a session, in principle turnaround time could be reduced to less than 1 day. The daily precise GPS orbits are produced from the same square-root filtering software used in the covariance analyses for hypothetical tracking scenarios about to be described. In the covariance analyses, assumptions for estimating parameters in the filter and for data quality were matched as closely as possible to those presently used for real GPS data analysis. If one were simply to raise the altitude of one GPS satellite from 20,200 to 37,000 km, we calculate that the orbit accuracy would degrade from 30–50 cm (presently achieved with real GPS data) to about 3 m [3,5]. The degradation results primarily from the very limited dynamical information when tracking a geostationary orbiter (GPS satellites move in 12-hr-period orbits).

Additional analysis was carried out to determine the minimum number of ground stations needed to track the geostationary “GPS” satellite. At this point, the analysis was modified to incorporate a GPS-like beacon (instead of a true GPS beacon). For a GPS-like beacon, we assumed a series of tones would be broadcast at Ku-band (12.5–18 GHz) with a 100-MHz bandwidth. These tones would be spaced so that an equivalent one-way range data type would be produced with 5-cm data noise over a 1-min averaging interval. As shown in Fig. 6(b), GPS ground receivers would be modified so that one out of the eight channels normally used to track GPS satellites would be equipped with a separate front end and a small, inexpensive antenna, enabling simultaneous tracking of seven GPS satellites and the one user satellite (TDRS in this case). As will be described later, a demonstration version of such a ground receiver is presently being built at JPL. There are many advantages of using such a modified GPS receiver. The simultaneous GPS tracking enables centimeter-level calibrations to be produced for receiver coordinates, troposphere and ionosphere delays, Earth orientation variations, and clock synchronization. The disadvantage is that since the ground receiver utilizes a different front end for GPS and the user satellite, a bias can be expected. Upon further investigation, we have found that this bias can be expected to wander slowly over about a day with a range of  $\pm 1$  nsec ( $\pm 30$  cm). This additional noise source is, in fact, a significant error source for the final result. With such a GPS-like beacon, a minimal network consisting of three NASA Deep Space Network (DSN) sites plus White Sands, New Mexico (WS), can support TDRS orbit accuracy of 10–15 m [5].<sup>2</sup> With six ground sites plus White Sands, the performance improves to 3–5 m (Fig. 7), and either network can support 50-m orbit determination within 2 hr after a maneuver (Fig. 8). The assumptions of the analysis are described in [5]. In all cases, a global network of GPS ground receivers provides the data strength for estimation of GPS orbits (Table 1). The filtering setup is nearly identical to that used presently for routine daily GPS orbit determination. This ensures that a realistic scenario is adopted for the error analysis. However, for this analysis, between four and seven GPS sites equipped with modified GPS receivers are capable of tracking both TDRS and GPS satellites (Fig. 8). In addition, the assumed errors for Earth orientation (UT1 and polar motion) were purposely made large to reflect knowledge of predicted values in real time.

<sup>2</sup> The analysis here assumes a global beacon signal from TDRS. As discussed below, continuously available TDRS phase and range data are available in a relatively small footprint centered around the southwestern United States. Hence, this study is applicable to a future TDRS configuration with a global beacon, not to the present configuration.

## V. Short-Baseline Differential Phase ( $SB\Delta\Phi$ ) for TDRS Tracking

The GPS-like beacon studies described above assumed a global distribution of ground sites for tracking a TDRS Ku-band beacon. For present-day TDRS satellites, however, the available carrier and ranging signals are predetermined by the current flight hardware, and these signals are restricted to a relatively small footprint (less than 1000 km) around White Sands, New Mexico.<sup>3</sup> In addition to Ku-band carrier phase, two-way range and Doppler are available at White Sands. The two-way range data are affected by relatively large uncalibrated time-varying errors and are typically assigned data weights of 30 m. An analysis in [6] took into account the data quality for the present-day TDRS carrier phase and two-way range within the limited footprint, and also included realistic error assumptions for effects of troposphere delay variations, ionosphere delays, systematic errors from solar radiation pressure mismodeling, and data noise. The ground network was assumed to consist of three stations within the footprint that are separated by between 1 and 100 km with a distributed clock. The distributed clock provides a common frequency reference over a fiber-optic link, providing considerable common error cancellation [9]. This setup is similar to that of connected element interferometry (CEI) [9] except that, for this TDRS analysis, we assumed that the phase biases between stations and the integer cycle ambiguity for the carrier phase are *not* resolved.

The station-differenced carrier phase observables from this tracking network provide a precise measure of plane-of-sky TDRS position. The two-way range data are necessary to determine the third component which, for a TDRS tracked from White Sands, includes much of the longitude component. Figure 9 shows the results of the covariance analysis for short-baseline differential phase ( $SB\Delta\Phi$ ) plus the two-way range at White Sands. Although the short baseline tracking does not generally do as well as tracking from a global network, as Fig. 9 shows,  $SB\Delta\Phi$  could in principle deliver 20-m orbit accuracy in a near-real-time operational system, depending on the quality of the two-way range data. The present-day two-way range is routinely assigned a weight of 30 m. We are investigating the sources of error for these data and hope eventually to be able to improve the calibrations needed to produce higher

<sup>3</sup> The bilateral ranging transponder system (BRTS) for TDRS includes two-way signals with a global network of transponder sites. These data are presently used for orbit determination. We did not include those sites in our orbit analysis because our goal was to develop an alternate tracking system in which all the tracking data can be collected locally and processed in an automated way. For this reason, we restricted our TDRS data to the current footprint near White Sands, New Mexico.

quality range data. While the goal is to achieve 1-m ranging, the TDRS tracking goal of 50 m could be met even with 5-m-quality two-way range. If 1-m ranging were available, the limiting orbit errors would be from unmodeled differential troposphere delay variations.

## VI. A TDRS Demonstration for $SB\Delta\Phi$ Using GPS-Like Tracking

In this section, we describe a demonstration experiment which will take place in late 1993. The demonstration combines the principles of both GLT and  $SB\Delta\Phi$ . Three GPS TurboRogue ground receivers are presently being modified at JPL to enable simultaneous tracking of TDRS Ku-band carrier phase in one channel and GPS L-band phase and pseudorange in the other seven channels. Small (meter-sized) inexpensive antennas will be used for the TDRS tracking, while the GPS signals will come through the regular omni antennas. Since creating a new fiber-optic distributed clock over 100 km around White Sands would be impractical for a proof-of-concept demonstration, instead we plan to use the GPS receivers themselves to provide clock synchronization for the three ground receivers near White Sands. Previous experimental work by Dunn et al. [10] has shown that sub-nanosecond GPS clock synchronization can be provided over intercontinental distances with high-quality GPS receivers. Because of the close proximity of the GPS receivers for this experiment, we expect that the time transfer will be substantially better than 1 nsec due to common error cancellation. We plan to space the receivers evenly around White Sands at several-hundred-kilometer distances. As discussed above, the quality of the White Sands two-way range is critical to the final accuracy achieved for the TDRS orbit. With minor software modifications, the TDRS carrier phase and two-way range data will be processed simultaneously in the GIPSY-OASIS II processor presently used for precise GPS and TOPEX/POSEIDON orbit determination. The data from the three new TDRS/GPS tracking sites near White Sands will be combined with GPS data from about 15 other globally distributed sites, which will provide a precise reference frame and enable sub-meter determination of the GPS orbits.

The use of GPS ground receivers modified for tracking the TDRS carrier phase (plus GPS) within the footprint has a number of advantages in addition to the relatively low cost. These advantages include "built-in" high-accuracy clock synchronization and troposphere, ionosphere (from the dual-band GPS signals at 1.2 and 1.6 GHz), and station location calibrations. In our experiment, the GPS receivers will perform the clock synchro-

nization function in place of the fiber-optic link for a distributed clock in  $S\Delta\Phi$ . Without the restrictions imposed by using a fiber-optic link, the baselines can be extended beyond the 100-km spacing, up to, essentially, the limit of the TDRS footprint (between 500 and 1000 km). The longer the baseline, the better the derived TDRS orbit due to the stronger geometry. Our goal for the TDRS/GPS demonstration is 50-m orbit accuracy, but the final result may be somewhat worse in the longitude component due to some uncertainty in the quality of the White Sands two-way range.

As an operational system, the small GPS/TDRS receiver network could provide turnaround of an hour or two if GPS predictions were used from a previous day for GPS orbits. A more accurate, fully combined solution with the GPS/TDRS data plus global GPS data would be available within a day or two. Reliable turnaround would be needed immediately (2 hr) after a TDRS maneuver to meet present-day operational requirements. The present-day prototype GPS analysis software at JPL is largely automated and could be the basis for such an operational system.

## VII. GPS-Like Tracking for Satellites Above Geosynchronous Altitudes

Tracking for orbit determination and navigation support at altitudes above the geosynchronous has been provided by observatories such as the DSN. Although conventional tracking data types (such as two-way Doppler and range) which are routinely used at the DSN could in principle provide 10–20-m orbit accuracy [11], this requires significant amounts of antenna time from either the DSN or subnets of smaller (approximately 10-m-sized) antennas. The best performance is expected from data types which require simultaneous tracking from more than one ground antenna [11], are more costly, and require careful scheduling of observations. For future orbiting astrophysical observatories expected to do very-long-baseline interferometry (VLBI) radio mapping and astrometric experiments, precise velocity knowledge is required to enable proper modeling of the data. Several of these future missions require velocity accuracies of 0.5 cm/sec. This level of accuracy can in some cases be provided by the existing DSN, but it is unlikely that the DSN can provide it at all points in the orbit [11]. In general, however, the scheduling of deep space antennas is the overriding concern because of the scarcity of available antenna time.

The use of small ground antennas and GPS receivers for tracking high Earth/elliptical orbiters along with GPS

satellites is attractive both because of the potential for freeing up significant amounts of expensive large antenna time at observatories and because of the high accuracy which is potentially achievable with the use of GPS technology. A recent analysis examined tracking for POINTS (Precision Optical Interferometer in Space), an optical astrometric mission for identification and characterization of planetary systems around other stars in the solar neighborhood.<sup>4</sup> This mission requires velocity determination to an accuracy of 0.5 mm/sec.<sup>5,6</sup> Clearly, conventional DSN tracking systems [11] cannot provide this level of accuracy (missing by 1–2 orders of magnitude). However, JPL's daily GPS orbit formal errors are at the level of 0.1 mm/sec. Even allowing for some accuracy degradation due to the higher altitude of POINTS (100,000 km) as compared with the GPS altitude (20,000 km), placing a GPS-compatible or GPS-like beacon on POINTS for orbit determination might be a viable approach.

The analysis assumes a nearly circular orbit at high altitude (100,000 km). A Ku-band beacon was assumed to be on the POINTS spacecraft with effective data noise of 5 cm over 1 min. A larger source of measurement noise results from electronic delays associated with the separate front end, which would be attached to the GPS ground receivers to enable reception of the POINTS signals. We assumed that these delays would be slowly varying, and estimated them in the filter as first-order Gauss-Markov process noise with an amplitude of 30 cm and a 12-hr time constant. Each of the six ground receivers would, therefore, be tracking up to seven GPS satellites at once, plus POINTS. A simulated data set was fit over a 4-day interval (one POINTS orbital period). The estimation and filtering strategy was selected to be nearly identical to that used at JPL for actual GPS data processing, with the exception that POINTS was included as well. Table 2 shows assumptions of the analysis, which includes systematic error contributions from POINTS solar-radiation pressure modeling, Earth orientation, relative station locations, and gravity. The differences between the assumptions for the POINTS error analysis and for the TDRS GPS-like beacon analysis reflect that TDRS requires a near-real-time

<sup>4</sup> B. L. Schumaker, D. B. Eldred, R. Ionasescu, J. W. Melody, R. N. Miyake, C. M. Satter, D. Sonnabend, J. S. Ulvestad, and G. Wang, *The POINTS Instrument for TOPS: 1991 Progress Report* (internal document), Jet Propulsion Laboratory, Pasadena, California, November 12, 1991.

<sup>5</sup> J. Ulvestad, *POINTS Orbit Determination Requirements* (internal document), Jet Propulsion Laboratory, Pasadena, California, July 6, 1992.

<sup>6</sup> B. J. Haines and S. M. Lichten, "POINTS Orbit Determination with GPS-Like Beacon," JPL Interoffice Memorandum 335.8-92-036 (internal document), Jet Propulsion Laboratory, Pasadena, California, December 8, 1992.

result and that the POINTS trajectory can be recovered after the fact. In addition, the POINTS analysis was for a year-2000 time frame, so some improved error assumptions were made. Figure 10 shows the expected orbit velocity and position errors for POINTS. Note that ground tracking of POINTS in this analysis was assumed to be available only 25 percent of the time (shown in Fig. 10). This limited tracking scenario accounts for the possibility that the spacecraft could be turned in such a way that the beacon would be pointing away from Earth, depending on where the astronomical sources were located in the sky.<sup>7</sup> Figure 10 shows that the POINTS solution is robust and, based on our assumptions about the capability to model forces on the satellite, can be predicted several days in advance without serious degradation of accuracy.

In summary, a high Earth orbiter (such as POINTS) can in principle be tracked to position accuracy of a few meters and velocity accuracy of 0.1 mm/sec if equipped with a GPS-like beacon at Ku-band and tracked from at least six modified GPS ground receivers which have been retrofitted so that the high Earth orbiter and GPS satellites can be processed simultaneously. For frequencies other than Ku-band, performance may vary slightly since the ionosphere delay calibration from the GPS L1 and L2 signals will have some error, and this will be more important at lower frequencies.

## VIII. Future Work

Future work on the GPS-based ground tracking techniques discussed in this article will focus on several different issues. These include the following:

- (1) *GPS-like beacon.* For future missions, we are studying desired signal structure and preliminary hardware design for a GPS-like beacon with the characteristics discussed above.<sup>8</sup> The goal is to use commercially available parts and keep power, mass, and cost to a minimum. The trade-offs between an L-band beacon and a Ku-band beacon are being studied as well. The choice of frequency may also depend on frequency allocations for transmitters, and these issues are being investigated as well.

- (2) *Altitude range.* The power and antenna patterns (for both the receiver and transmitter) will ultimately limit the distance from which the beacon signal could be detected with small, inexpensive ground antennas. With a properly designed system, missions in interplanetary space could also use the new proposed technology with a GPS-like beacon. Since, ordinarily, deep space missions require significant amounts of tracking time with oversubscribed large DSN antennas, considerable resource conservation and savings could result.
- (3) *Geosynchronous analysis.* It is planned to have the TDRS field experiment data collected in late 1993 and analyzed in 1994. The spatial limitations and noise characteristics of the existing TDRS signals will probably determine performance for present-day TDRS tracking. If the experiment is a success, the new tracking techniques could enhance present or future TDRS operations, or provide an alternative method for tracking other geosynchronous satellites. Because even very short (1-km) baselines could provide moderately accurate (50-m) orbit operations (see Fig. 9), secure ground systems could be designed for military applications as well.
- (4) *Modified GPS ground receivers.* The performance of the modified GPS ground receivers used to track TDRSs will be monitored closely in the field experiment. Enhanced designs will be considered, including receivers with more channels to serve additional satellite "customers" simultaneously. One key calibration is the bias introduced by using a different front end or antenna to process the high Earth orbiter data as opposed to the GPS data. This "bias" is actually expected to slowly vary in time with an amplitude of approximately 1 nsec (30 cm). If the temporal behavior can be better stabilized and the amplitude of the variation can be reduced, significantly improved performance would result. The minimum number of stations in the ground network with modified GPS receivers will also be considered for different applications.

## IX. Summary

This article describes analyses for tracking satellites at high (geosynchronous or higher) altitudes with two techniques: GPS-like tracking (GLT) with a simple on-board beacon, and short-baseline differential carrier phase (SBD $\Phi$ ) with a distributed clock. The proposed tracking system dispenses with flight GPS receivers on certain high-altitude satellites for which precise orbit determination is

<sup>7</sup> Since that analysis was completed, however, a new spacecraft design has been developed which allows for placement of two beacon transmitter antennas on opposite sides of the spacecraft so that coverage of the Earth is possible more than 75 percent of the time; see footnote 8.

<sup>8</sup> C. Dunn and L. Young, "POINTS Navigation Beacon Strawman Design," JPL Interoffice Memorandum 335.9-003-93 (internal document), Jet Propulsion Laboratory, Pasadena, California, January 29, 1993.



desired, and also requires no DSN antenna time for orbit determination or navigation functions. Instead, a beacon transmits a series of tones which can be detected in modified GPS ground receivers. In the ideal case, the satellite with the beacon can be tracked to an accuracy comparable to that attainable for GPS satellites themselves, even though the beacon may be at a different frequency than the GPS L-band. In practice, we expect some degradation relative to the GPS satellite orbits if the beacon satellite is at a higher altitude or has restricted ground coverage for other reasons. At the present time, orbits for GPS satellites can be determined on a daily basis to about 30–50-cm accuracy. Detailed analysis has been completed for geosynchronous orbiters (TDRSs). With a global beacon at Ku-band and GLT, TDRS orbit determination accuracy of a few meters would be theoretically possible. However, we also considered using TDRS carrier phase restricted to a relatively small footprint in the southwestern United States and a fairly coarse accuracy two-way range observable. For the current TDRS capability, the study initially focused on SB $\Delta\Phi$  with a fiber-optic link providing a distributed clock to three sites in close proximity. This article presents a hybrid tracking scheme which combines elements of the GLT and SB $\Delta\Phi$  techniques for a demonstration experiment planned for late 1993. For this experiment, three GPS ground receivers are being retrofitted to enable simultaneous tracking of TDRS and GPS satellites. Anticipated orbit accuracy for TDRS is in the 20–50-m range, with the caveat that the longitude component could be degraded by a factor of about five due to unknown errors in the presently available TDRS two-way range. The small tracking network to be tested in the demonstration experiment would offer a number of opera-

tional advantages for orbit determination of TDRS or any other geosynchronous satellite. Figure 11 summarizes the relationship between present-day GPS orbit determination accuracy and how anticipated performance for tracking TDRS in the demonstration depends on various data restrictions and limitations.

The covariance analysis for a satellite (POINTS) in a 100,000-km near-circular orbit shows that few-meter position (and <0.1 mm/sec velocity) accuracy could be achieved with a minimal tracking network consisting of only six ground sites equipped with the modified GPS receivers. The analysis assumed that due to blockage on the satellite only 25 percent of the data would be available and shows that, even with such a limitation, the GLT-based solution is very robust.

Operationally, the advantages of the GLT and SB $\Delta\Phi$  concepts discussed in this article include the low cost of small antennas and GPS receivers in comparison with larger antennas and systems typically used for Earth orbiter ground-based tracking; high accuracy from cancellation (or calibration) of media, Earth platform, and timing errors with the simultaneous observations of the GPS and the high Earth orbiters; and operational convenience available from existing rapid communication links and automated processing of GPS (and GPS-like) data. Use of the GPS-based ground tracking system for high Earth orbiter tracking could result in substantial operational savings compared to technology presently being used. In the case of the DSN, very scarce large antenna time would remain available for interplanetary tracking and telemetry.

## Acknowledgments

Figure 3(b) was provided by J. Zumberge, and Figs. 4 and 5 by S. C. Wu.



## References

- [1] W. Bertiger, S. C. Wu, T. P. Yunck, R. J. Muellerschoen, Y. Bar-Sever, E. S. Davis, S. M. Lichten, T. N. Munson, and P. Willis, "Early Results from the TOPEX/POSEIDON GPS Precise Orbit Determination Demonstration," paper AAS 93-154 presented at the AAS/AIAA Space Flight Mechanics Meeting, Pasadena, California, February 22-24, 1993.
- [2] S. C. Wu, "Differential GPS Approaches to Orbit Determination of High-Altitude Earth Satellites," paper AAS 85-430 presented at the AAS/AIAA Astrodynamics Conference, Vail, Colorado, August 12-15, 1985.
- [3] S. C. Wu, T. P. Yunck, S. M. Lichten, B. J. Haines, and R. P. Malla, "GPS-Based Precise Tracking of Earth Satellites from Very Low to Geosynchronous Orbits," *Proceedings of the National Telesystems Conference*, Ashburn, Virginia, pp. 4-1-4-8, May 19-20, 1992.
- [4] S. M. Lichten and J. A. Estefan, "High-Precision Orbit Determination for High-Earth Elliptical Orbiters Using the Global Positioning System," paper AIAA-90-2954 presented at the AIAA/AAS Astrodynamics Conference, Portland, Oregon, August 20-22, 1990.
- [5] B. J. Haines, S. M. Lichten, R. P. Malla, and S. C. Wu, "Application of GPS Tracking Techniques to Orbit Determination of TDRSS," paper presented at the Flight Mechanics/Estimation Theory Symposium, Greenbelt, Maryland, May 5-7, 1992.
- [6] S. Nandi, C. D. Edwards, and S. C. Wu, "TDRSS Orbit Determination Using Short Baseline Differenced Carrier Phase," paper presented at the Flight Mechanics/Estimation Theory Symposium, Greenbelt, Maryland, May 5-7, 1992.
- [7] S. M. Lichten and W. I. Bertiger, "Demonstration of Sub-Meter GPS Orbit Determination and 1.5 Parts in  $10^8$  Three-Dimensional Baseline Accuracy," *Bulletin Geodesique*, vol. 63, pp. 167-189, 1989.
- [8] J. F. Zumberge, G. Blewitt, M. B. Heflin, D. C. Jefferson, and F. H. Webb, "Analysis Procedures and Results From the 1992 IGS Campaign," *EOS Trans. AGU (Suppl.)*, vol. 73, no. 43, p. 134, October 27, 1992, and presented at the Fall AGU Meeting, San Francisco, California, December 7-11, 1992.
- [9] C. D. Edwards, "Development of Real-Time Connected Element Interferometry at the Goldstone Deep Space Communications Complex," *Proceedings of the AIAA/AAS Astrodynamics Conference*, Portland, Oregon, pp. 324-334, August 20-22, 1990.
- [10] C. E. Dunn, S. M. Lichten, D. C. Jefferson, and J. S. Border, "Subnanosecond GPS-Based Clock Synchronization and Precision Deep-Space Tracking," *The Telecommunications and Data Acquisition Progress Report 42-111*, vol. July-September 1992, Jet Propulsion Laboratory, Pasadena, California, pp. 1-10, November 15, 1992.
- [11] J. A. Estefan, "Precise Orbit Determination of High-Earth Elliptical Orbiters Using Differenced Doppler and Range Measurements," *The Telecommunications and Data Acquisition Progress Report 42-106*, vol. April-June 1991, Jet Propulsion Laboratory, Pasadena, California, pp. 1-22, August 15, 1991.

**Table 1. Error models for TDRS GLT error analysis.**

A priori for estimated parameters	
Parameter	Value
TDRS position (X, Y, Z)	5 km
TDRS velocity (X, Y, Z)	50 m/sec
TDRS solar radiation pressure	5%
GPS position (X, Y, Z)	100 m
GPS velocity (X, Y, Z)	1 m/sec
GPS solar radiation pressure	25%
GPS Y-bias	$10^{-12}$ km/sec <sup>2</sup>
GPS carrier phase biases	0.003 sec
GPS/TDRS/station clocks	0.001 sec white noise
Zenith troposphere	40 cm (a priori) + 12 cm/ $\sqrt{\text{day}}$ random walk
Consider parameters*	
Parameter	Value
DSN station coordinates	3 cm
Non-DSN station coordinates	10 cm
GM Earth	2 parts per billion
Lumped Earth gravity field	25% GEM-10 – GEM-L2
X-, Y-pole motion	25 cm
UT1-UTC	0.6 msec

\* Not estimated, treated as systematic errors.

**Table 2. Estimation strategy for joint GPS/POINTS orbit determination.**

Data noise (30-min observations)	
Parameter	Value
GPS carrier phase	1 cm
GPS P-code pseudorange	30 cm
POINTS Ku-band beacon case	5 cm random noise over 1 min
POINTS pseudorange (tones)	+30 cm/12 hr systematic error (estimated)
A priori for estimated parameters	
Parameter	Value
POINTS position (X, Y, Z)	5 km
POINTS velocity (X, Y, Z)	50 m/sec
GPS position (X, Y, Z)	100 m
GPS velocity (X, Y, Z)	1 m/sec
GPS solar radiation pressure	25%
GPS Y-bias	$10^{-12}$ m/sec <sup>2</sup>
GPS carrier phase biases	1 sec
GPS/POINTS/station clock errors	1 sec white noise
Zenith troposphere	40 cm a priori +5 cm/ $\sqrt{\text{day}}$ random walk
Consider parameters*	
Parameter	Value
POINTS solar radiation pressure	2%
Polar motion (X, Y)	5 cm
Geocentric location (X, Y, Z)	5 cm
Earth rotation (UT1-UTC)	0.1 msec
Station locations (X, Y, Z)	1 cm
Earth gravitational constant	1 part per billion
Geopotential field (lumped)	25% GEM-10 – GEM-L2

\* Not estimated, treated as systematic errors.

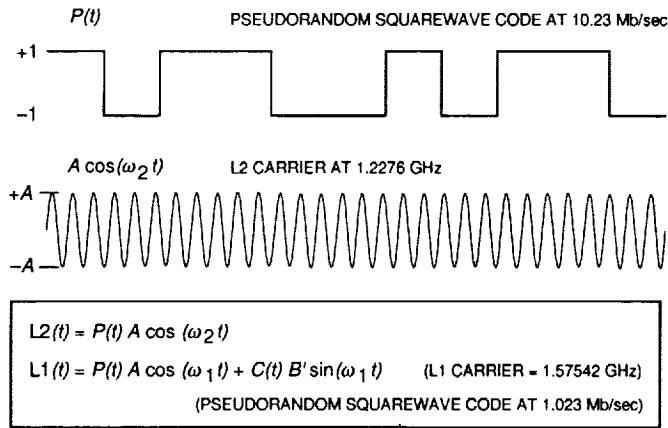

Fig. 1. GPS carrier phase is modulated by the P-code,  $P(t)$ , and the C/A code,  $C(t)$ . The codes include data bits (not shown above) with information about GPS orbits and clocks. Carrier phase and high-precision pseudorange obtained from either code or codeless tracking techniques are used in high-accuracy GPS applications. For lower accuracy applications, an inexpensive C/A-code-only GPS receiver may be adequate.

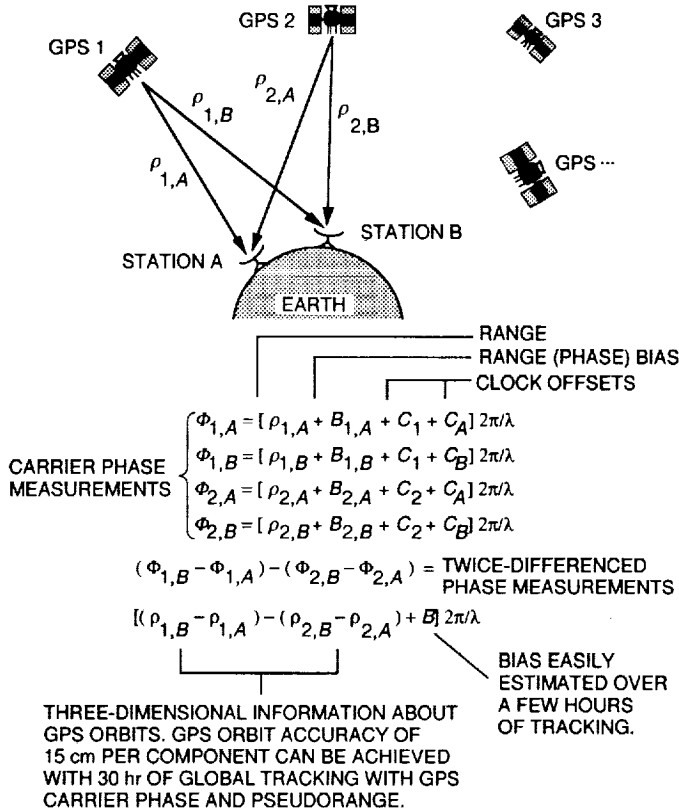

Fig. 2. Differential GPS tracking. Kalman filter simultaneously estimates GPS orbits, biases,  $B$ , and clock parameters,  $C$ , instead of explicitly differencing data. Pseudorange data tightly constrain clocks and biases and result in a more accurate solution than is achieved with explicitly differenced data.

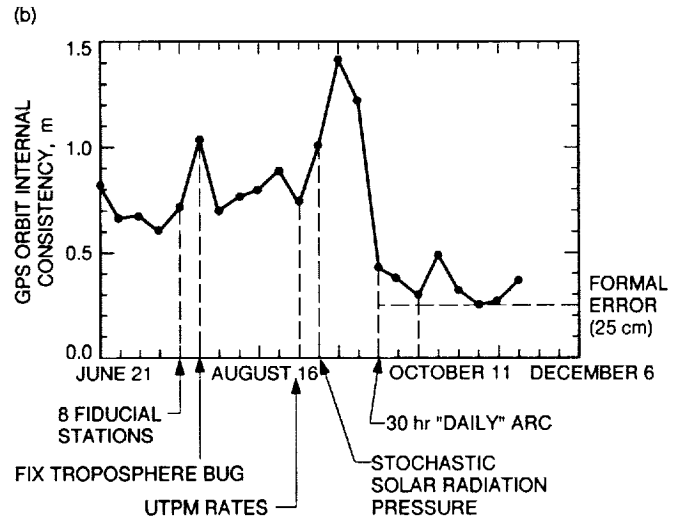
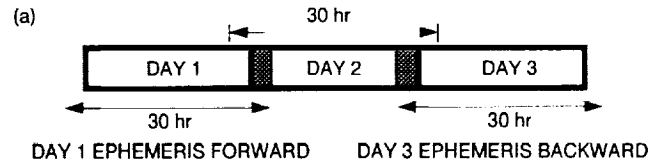

Fig. 3. JPL GPS orbit quality: (a) assessment from daily GPS precise orbit determination, rms computation over 3 hr, and (b) evolution in 1992 using orbit repeatability from day to day similar to that in (a). Present-day results show three-dimensional precision of 30–50 cm, corresponding to 15–25 cm per orbit component.

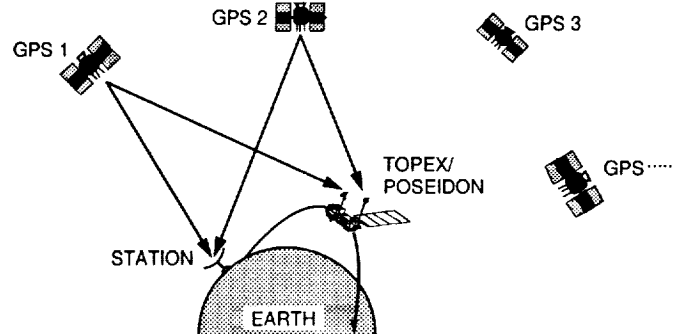
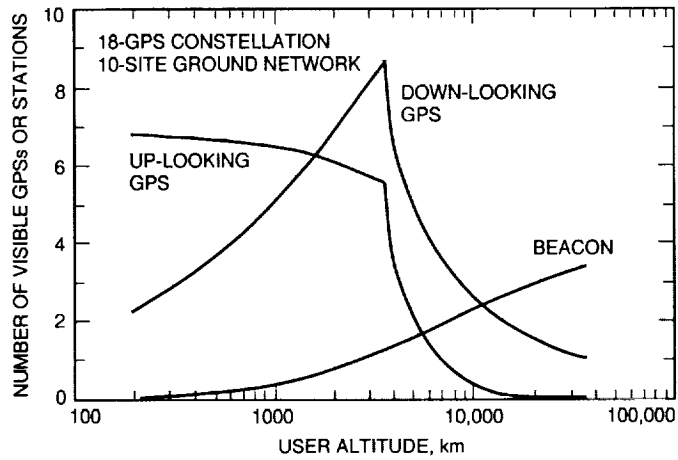
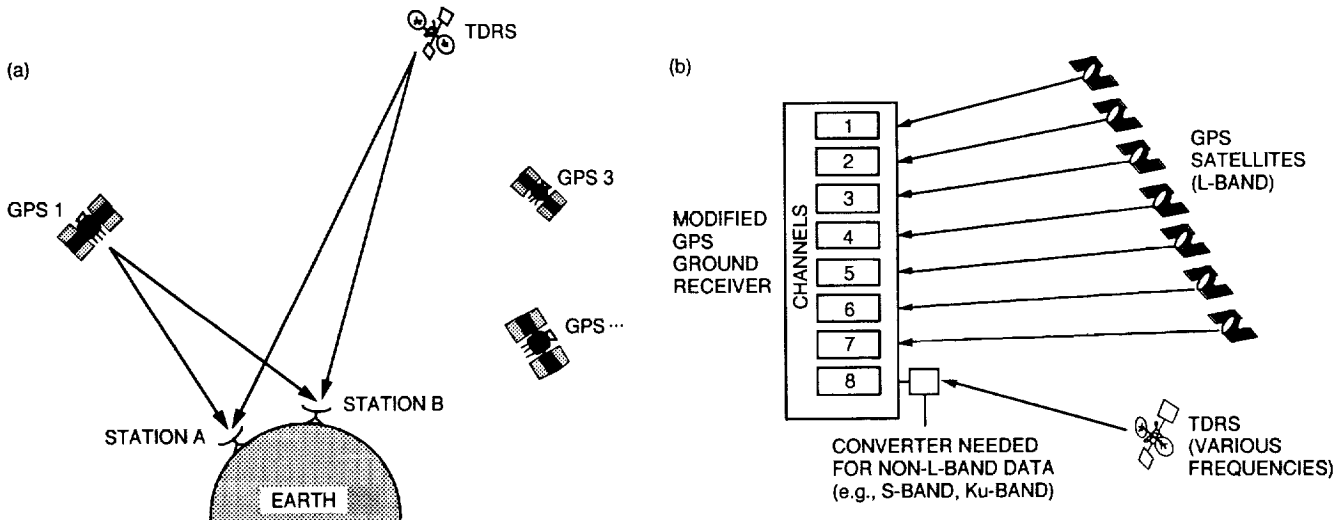

Fig. 4. Geometry for low Earth orbiter tracking with a GPS flight receiver. Simultaneous measurements with common satellites and receivers are necessary for estimation of clock offsets in high-precision applications.



**Fig. 5. Average number of GPS satellites in view for a satellite carrying a flight receiver (up-looking and down-looking GPS), and average number of ground stations in view as seen from a user satellite with a GPS-like beacon. The satellite is equipped with a GPS-like beacon that can be tracked simultaneously with the GPS signals by a GPS ground receiver.**



**Fig. 6. GLT concept: (a) a high Earth orbiter is equipped with a beacon that can be tracked in GPS ground receivers. The orbit determination problem is similar to a hypothetical GPS orbit determination with one "GPS" satellite at higher altitude, and (b) a GPS ground receiver modified to simultaneously track a high Earth orbiter along with GPS satellites. For a satellite such as TDRS, which broadcasts at frequencies outside the GPS L-band (1.2–1.6 GHz), a small separate antenna with a downconverter would be added to the GPS ground instrument.**

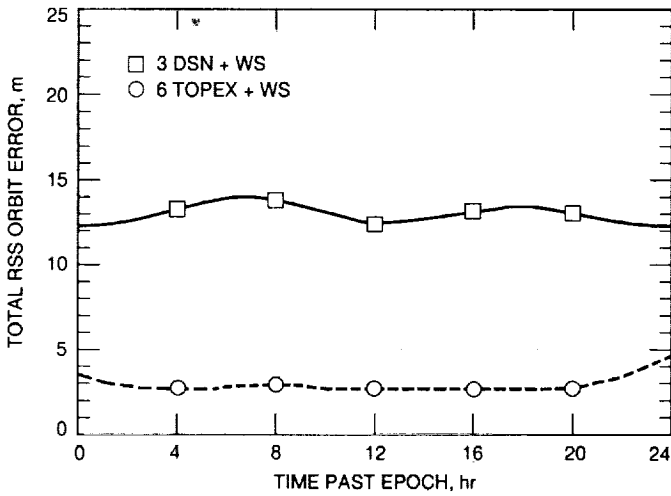

Fig. 7. Expected orbit accuracy for a geosynchronous orbiter (TDRS) equipped with a hypothetical beacon with Ku-band tones to provide a one-way range observable tracked from a global network of four or seven ground sites with modified GPS receivers. The modified GPS receivers would be as shown in Fig. 6(b).

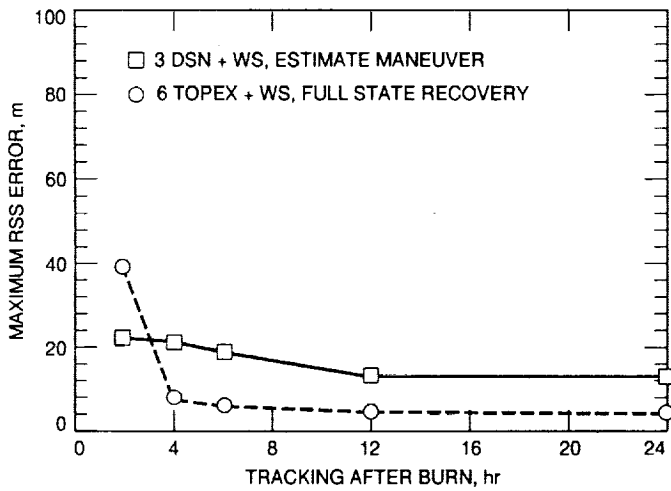

Fig. 8. Expected orbit accuracy corresponding to Fig. 7 after a maneuver for a four-site network where the maneuver is modeled and estimated, or with a seven-site network where an independent new determination of the full state is made.

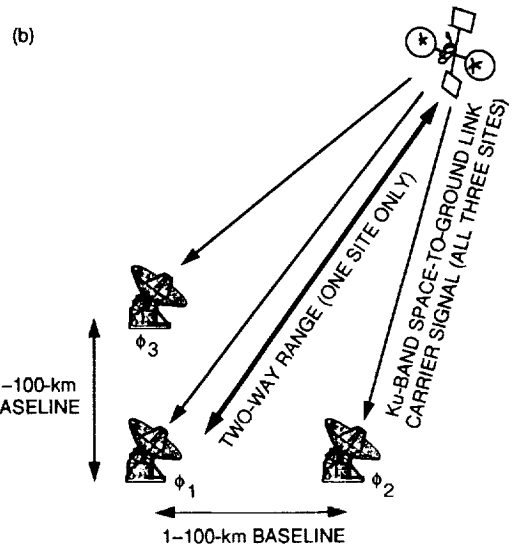
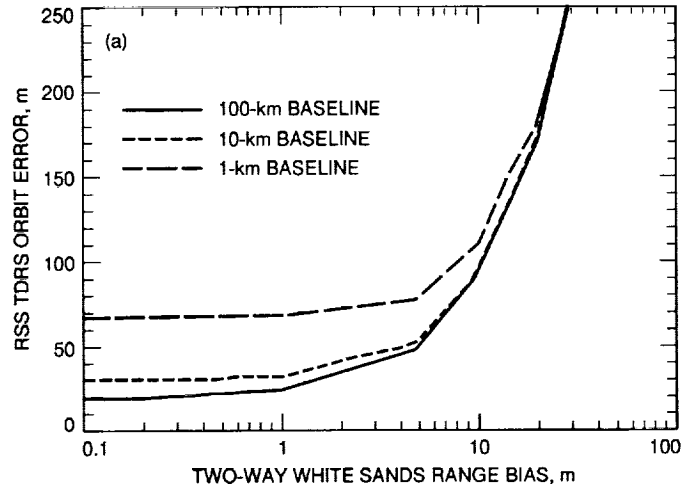

Fig. 9. Hypothetical TDRS tracking with short-baseline differential carrier phase and distributed (connected element) clock plus two-way range to one of the three sites: (a) expected accuracy and (b) schematic of ground network and data links.

53-18  
198553

P-10

N94-23259

# Improved Thermal Force Modeling for GPS Satellites

Y. Vigue

Tracking Systems and Applications Section

R. E. Schutz and P. A. M. Abusali

Center for Space Research, University of Texas, Austin, Texas

*Geophysical applications of the Global Positioning System (GPS) require the capability to estimate and propagate satellite orbits with high precision. An accurate model of all the forces acting on a satellite is an essential part of achieving high orbit accuracy. Methods of analyzing the perturbation due to thermal radiation and determining its effects on the long-term orbital behavior of GPS satellites are presented. The thermal imbalance force, a nongravitational orbit perturbation previously considered negligible, is the focus of this article. The Earth's shadowing of a satellite in orbit causes periodic changes in the satellite's thermal environment. Simulations show that neglecting thermal imbalance in the satellite force model gives orbit errors larger than 10 m over several days for eclipsing satellites. This orbit mismodeling can limit accuracy in orbit determination and in estimation of baselines used for geophysical applications.*

## I. Introduction

Mismodeling of satellite force parameters can have a significant effect on satellite orbits, especially in orbit prediction [1]. Some applications require the capability to estimate and propagate satellite orbits with high precision. TOPEX/POSEIDON precision orbit determination, for example, requires precise modeling of nongravitational forces to fulfill mission requirements [2]. In addition, some of the observed drag and orbit decay on the Laser Geodynamics Satellite (LAGEOS) spacecraft have been attributed to unmodeled thermal forces [3,4]. To achieve a high level of orbit accuracy, an accurate model of all the forces acting on an Earth-orbiting satellite is necessary.

The focus of this analysis was to assess the effects on satellite orbits of neglecting thermal reradiation and

of mismodeling nongravitational forces. Radiative heat transfer between a satellite and its environment is the basis for the thermal force model. A satellite in Earth orbit is continuously illuminated by radiation, most of which comes from the sun. The thermal imbalance force is directly related to the temperature distribution of the satellite in its changing environment. An uneven temperature distribution causes surfaces to reradiate energy at different rates. Some studies have shown that most of the thermal gradient forces on the TOPEX/POSEIDON satellite originate within the spacecraft body [2]. Other analyses have shown that the dominant source for thermal reradiation forces on a Global Positioning System (GPS)-like satellite is the solar panels, due to their large exposed area and low heat capacity [5]. The satellite's heated body reradiates energy at a rate proportional to its temperature, losing the energy in the form of photons. By conservation