

N94-23854

NASDA SATELLITE MISSION OPERATION SYSTEM AND OPERATIONS

Kousaku Yamaya, Fumiyoshi Yoshida, Harushige Noguchi,
Tetsuo Takahashi and Kazuhiro Tanaka

National Space Development Agency of Japan
Tsukuba, JAPAN

ABSTRACT

NASDA has recently developed a new tracking and control system as a basis of for future satellite mission operation. It is named type-I Space Operations and Data Systems (type-I SODS). The software of this system is separated into three parts: 1)operation and control system, 2)network system, 3)support and information system. The operation control system treats telemetry and command operations. The network system controls the communication line and ground station equipments to connect the satellite and the operation control system. The support and information system provides to other systems necessary information. JERS-1 which was launched in february of this year is the first satellite operated by type-I SODS. We explain the architecture and operation methods of this system using JERS-1 mission operations.

Key Words:satellite operation, network, planning system

1. INTRODUCTION

NASDA has launched many types of satellites since 1975. For operating these satellites, we have developed many equipments and software. Meanwhile, after 1990's a satellite which requests very complex operation is forecasted. To operate this complex satellite efficiently, it is needed to develop a new system ,to adjust systems which already exist and to integrate these systems. As the first

step of a new system, NASDA developed a ground network operation system. This is called type-I SODS. This paper introduces this system and its operations.

2. SYSTEM ARCHITECTURE OF TYPE-I SODS

Type-I SODS consists of many hardware and software. In the first place, this paper explains the outline of these components.

2.1 Hardware elements

NASDA has four s-band ground tracking stations and one satellite operation center. Three of four stations are in JAPAN and each station has two s-band facilities. One station is in SWEDEN and it has one s-band facility. All facilities consists of antenna, transmitter, receiver, range and range rate equipment, base band equipment, data transmission computer and station control computer. Functions and performance of these facilities are almost standardized except the antenna and the base band equipment. The differences among antenna equipments are acquisition antenna existence and the antenna mounting type. The difference among base band equipments is whether the base band equipment has the function of keeping stored telemetry or not.

The satellite operation center is in Tsukuba, called Tracking And Control Center (TACC). There are line exchange equipment, main frame computer, several mini-computers and workstations and many personal

computers serving as terminals of these computers.

2.2 Software

The software of SODS is classified into three categories. The first is the operation and control system. The second is the network system. The third is the support and information system. The component of these systems is explained below.

2.2.1 The operation and control system

This system is responsible for the satellite telemetry and command operations. It is composed of Satellite Operation and Control System(SOCS), Satellite Telemetry and Operated Command Keeping System(STOCK) and Satellite dataBASE(SBASE). The function of SOCS is to send commands and to display telemetries. STOCK is a batch system to handle telemetry and command history. SBASE manages satellite information about command and telemetry.

2.2.2 The network system

The network system controls ground station equipments and line exchange equipment to connect a satellite on orbit and the operation and control system in TACC. This system consists of Tracking and control Station system(TS), sTation network control system(TC), communication Line Control system(LC) and Network Management system(NM). The TS is installed in the station control computer of ground stations and controls ground station equipments. The LC controls line exchange equipment. The TC is a front-end system of TACC for station control. The NM supervises network system over all.

There is one more software which belongs to the network system. It is gateway system(GW), which is responsible for connecting NASDA's

network and foreign agency's network. In this paper, the detailed explain of GW is omitted.

2.2.3 The support and information system

This system provides necessary information to other systems. It consists of flight dynamics system(FDS), Network Planning system(NP) and Satellite operation Planning system(SP). FDS has functions to determine satellite orbits, to plan orbit maneuver, and to calculate prediction. NP schedules network operations and generates network plans. SP is responsible for accepting satellite operation requests, making command sequence and sending it to SOCS.

3. THE OPERATION AND CONTROL SYSTEM AND ITS OPERATIONS

The data interface between SOCS, STOCK and SBASE is shown in Fig.1.

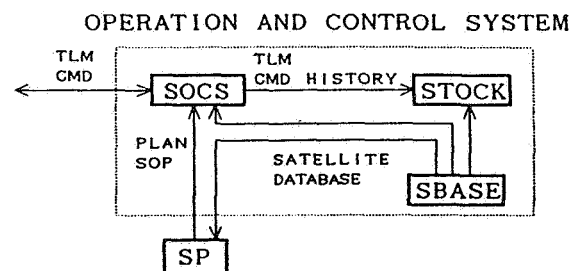

Fig.1 Data interface of the operation and control system

SOCS is developed for each satellite mission project. It is installed in two or three mini-computers to guard against computer failure. NASDA has now 5 mini-computers for SOCS. Ordinarily we use one mini-computer for one satellite operation, but in case of simple satellites, we use one computer for 2 satellites' operations. Thus we keep the operational flexibility.

To understand the SODS operation, the

command setting method of SOCS must be explained. SOCS has three methods for command setting. The first is the manual method. The operator types commands to send by SOCS editor. The second method is SOP calling. SOP is made by SP, and it consists of sets of commands and telemetries which must be verified after command sending. In case of the SOP calling method, SOCS displays the telemetries defined in SOP at the moment of command sending. But, if a command in SOP has parameters (for example time, magnitude value), the operator must determine it before command sending. The third method is calling PLAN. PLAN is also made by SP. PLAN consists of commands and SOPs of which parameters are already determined by SP. When the operator sets commands by PLAN calling, command editing is not needed.

Since, in the case of JERS-1, the operation is very complex, an operator uses the PLAN calling method. The PLAN is called 10 minutes before the operation start. In the case of a simple satellite, SOP calling method is usually used for command setting.

STOCK receives telemetry and command operation history from SOCS every day. STOCK has functions of keeping telemetry and command history, drawing telemetry graph, and printing the kept

data. STOCK is used for the satellite analysis.

SBASE is used to manage satellite database. It is mainly telemetry and command information, for example, telemetry word assign information, information to change from digital data to analog value, command name table, command verify information and so on. Satellite database is used by SOCS, STOCK and SP. SBASE has a function to notify the change information to other system.

4. THE NETWORK SYSTEM AND ITS OPERATION

This system operates according to the network plan which is made by the network planning system. In this section, we explain the action of network system as a whole and do not explain the individual software function. The interface of NM, TC, LC and TS is indicated in Fig.2.

4.1 Contents of a network plan

There are three kinds of network plans. The first plan is the normal network plan. It is a plan for satellite operation. The second plan is the stored telemetry transmission plan. This plan is used for sending stored telemetry which have been kept in base band equipment. The third plan is a dummy plan used to secure ground

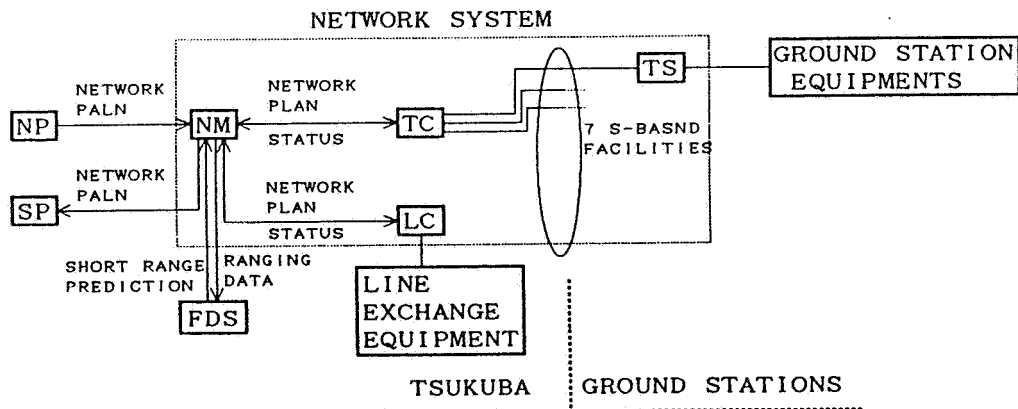

Fig.2 Data interface of the network system

station or SOCS computer from other network request. The last plan is used in case of hardware maintenance, development test and so on. A network plan mainly consists of the following elements.

- a) start time and end time
- b) satellite name
- c) ground station name
- d) SOCS computer name
- e) network operation

A network operation is a combination of these five elements: 1) telemetry, 2) command, 3) stored telemetry, 4) ranging, 5) 1-way doppler. In the case of a geostational satellite, the period of command, ranging or 1-way doppler is added to the network plan.

4.2 Network plan delivery

A network plan is made by NP. After NP makes network plans, NP send them immediately to NM. On the other hand, NM takes new prediction from flight dynamics system. NM always searches network plans, and if it finds the network plan which starts within 2 days, it appends the prediction to the network plan and sends it to LC and TC. When a network plan is sent to TC, TC sends it to TS without delay. Thus a network plan is sent and kept in TS and LC.

4.3 Equipment control of LC

The network plan is automatically carried out at the start time. LC controls line exchange equipment so that specified ground station and SOCS computer is connected.

4.4 Equipment control of TS

TS also starts to control equipments. In the case of normal network plan, the sequence of control is as follows.

- 1) control mode check phase
- Equipments of ground station have two

control mode. One is the local control mode and the other is the program controlled mode. It is selected by the station operator. When a network plan starts, TS confirms whether the control mode is program or not. If the mode is wrong, TS alarms the station operator by the recorded voice.

- 2) readiness check phase

TS sets equipment to test configuration and checks these functions: antenna motion, telemetry receiving and demodulating, command sending, ranging data acquisition and 1 way doppler data acquisition. If any anomaly is found, TS notifies the operator.

- 3) operation parameter set phase

TS changes equipments configuration from test to operation.

- 4) antenna pointing phase

TS controls antenna equipment to orient satellite AOS direction.

- 5) satellite acquisition

After antenna orientation, TS waits for AOS of satellite. Antenna is driven according to the prediction. After the elevation angle of antenna arises above 2 degrees, TS checks the signal level. If the signal level is lower than the forecasted value, TS gives offset angle, which is equal to half of the beamwidth of antenna, to prediction angle for two axes and for plus and minus directions in order to avoid side beam lock. And TS searches the point where the highest signal level is obtained. On the condition of a good signal level, TS changes antenna drive mode from prediction to automatic tracking. After changing, TS confirms the mean and the standard deviation of tracking error angle.

If at first an acquisition antenna is used, TS changes to the main antenna after auto tracking become stable. Then TS confirms the difference of signal levels to avoid side beam

acquisition.

The received telemetry is demodulated, synchronized and sent to SOCS via the data transmission computer. By the way, the stored telemetry is kept in the base band equipment. This data is sent to SOCS later by stored telemetry transmission plan or remote operation from TACC.

6)uplink control phase

If command or ranging is planed in the network plan, TS controls the transmitter. The start timing of control is different between low orbit satellite case and geostationary satellite case.

In case of a low orbit satellite, TS starts to control the transmitter when the antenna rises above 5 degrees. In case of a geostational satellite, the period of uplink is indicated in the network plan. First, uplink frequency is swept in the direction which is determined by the predicted doppler. And TS verifies the satellite receiver status. After TS recognizes the satellite receiver lock, TS modulates the uplink.

If ranging or 1-way doppler is planed in the network plan, TS controls the ranging equipment. After the ranging data acquisition starts, TS confirms the measured value. If the difference between the measured value and the prediction value is large, TS stops data acquisition and retries once more.

7)operation terminate phase

In the case of a low orbit satellite, TS turns off the uplink when antenna elevation angle goes down below 5 degrees. And antenna drive mode is changed from auto tracking mode to prediction mode when antenna elevation angle goes down below 2 degrees. After the receiver loses satellite signal, TS tidies up equipments and terminates the network operation. In case of a

geostationary satellite, TS starts to tidy up equipments two minutes before network plan end time.

4.5 Network status monitor

TS always sends status of ground station equipment to TC. So, operators in Tsukuba can watch all station equipment status by the TC terminal. Also LC displays the line connection status, and that, operators in TSUKUBA can watch all NASDA network status.

4.6 Ranging data transmission

TS also sends the ranging data or the 1-way doppler data to NM via TC. They are kept in NM, and FDS gets them in batch operation.

4.7 Network control

As explained above, operators in Tsukuba need not directly control the network system. But, to cope with various situations, Network system allows operator to override network operations. Examples of control items are, interruption of network plan, extension of network plan, time offset of prediction, stored telemetry transmission, health check, and so on. Operators can control more detailed items as they were in front of ground station equipment.

5. THE SUPPORT AND INFORMATION SYSTEM AND ITS OPERATIONS

The support and information system is composed of systems as mentioned. The relation of the three systems is shown in Fig.3.

5.1 Flight dynamics system

Flight dynamics system(FDS) is responsible for determining the satellite orbit, making orbit maneuver plan, and providing satellite prediction. This system provides two kinds of predictions. One is the long

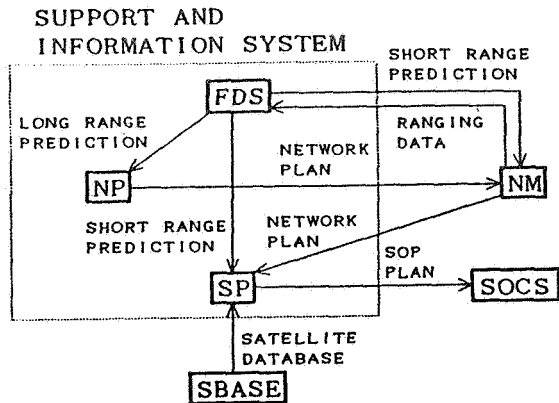

Fig.3 Data interface of the support and information system

range prediction and the other is the short range prediction. The former is used for network planning. The period of prediction is two or three months and the flight dynamics system makes it every month. The latter prediction is used for antenna driving and satellite operation planning. The period of prediction is 2 or 3 weeks. The interval of making prediction depends on the satellite. In case of JERS-1, the flight dynamics system provides it every day.

5.2 Network planning system

Network planning system(NP) is responsible for making network plan. NP accepts user's requests to use the network, assigns the stations and SOCS computers, and determines the network operation. NP makes monthly network plans one month prior to the start of the network plan. And NP renews network plans every week. Of course, if some emergency occurs, the network plan is renewed as soon as possible. NP has a function to print monthly, weekly, and daily network plans for network and satellite operators.

5.3 Satellite operation planning system

Satellite operation planning system(SP) is responsible for making

PLAN and SOP which is explained in section 3. Performance and operation of SP is different for each satellite operation planning system. In this paper, we explain the JERS-1 case.

SP of JERS-1 has the following functions.

- 1)read the event procedure written in Japanese.
- 2)pick up commands to send and telemetries to be confirmed in order to make SOP.
- 3)get network plan and determine operation style.
- 4)read operation request.
- 5)get prediction and make PLAN.
- 6)print revolution operation procedure.

The event procedure is a relatively short and definite procedure for satellite operation. It is prepared and SOP is made before launch.

In the operation phase, the operator of SP gets network plans from NM every week and determines the rough operation style. The operation style indicates whether the revolution is used for main operation or back up operation. Then, SP accepts mission operation requests and makes PLAN. But, parameter of time is not determined yet. SP determines the command time using the newest prediction every day. After making PLAN, SP sends it to SOCS.

6. CONCLUSIONS

NASDA has developed type-I SODS successfully. Presently, NASDA is preparing to operate the satellites which were launched before JERS-1 by type-I SODS. We are going to operate all satellites by type-I SODS next year. Meanwhile NASDA is developing the experiment equipment for inter-satellite communications. Next target of SODS is to integrate space network systems.