

NASA-CR-195541

NASW-4435



1N-12-CR

204261

p. 88

Preliminary Design Review for

PERCIVAL Mission To Mars

ARES INDUSTRIES
A SUBSIDIARY OF THANATOS INDUSTRIES

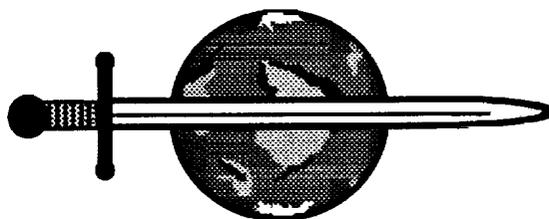

N94-24995

Unclas

G3/12 0204261

SUBMITTED TO:
Dr. George Botbyl
Department of Aerospace Engineering
University of Texas at Austin

IN SUPPORT OF:
NASA / USRA
Advanced Space Design Program

SUBMITTED BY:
Ares Industries
The University of Texas at Austin
December 10, 1992

(NASA-CR-195541) PERCIVAL MISSION
TO MARS Preliminary Design Review
(Texas Univ.) 88 p



Ares Industries Design Team Personnel
Fall 1992

TEAM LEADER
David W. Reed

CHIEF ENGINEER
Stewart Lilley

CHIEF ADMINISTRATOR
Melinda Sirman

ENGINEERS
Paul Bolton
Susan Elliott
Doug Hamilton
James Nickelson
Artemus Shelton

Acknowledgments

Ares Industries wishes to thank all of those in industry and academia who helped make the Percival Mission to Mars possible.

Among those we wish to thank from industry are Dr. Paul Robinson, Assistant Chief Technologist for JPL; Bill Blume, Mars Observer Mission Planner at JPL; and Dave Kaplan and John Conolly, both of the Lunar and Mars Exploration Office.

Many of the people from the University of Texas at Austin were very helpful in the design of the Percival mission. We would like to thank Dr. Wallace Fowler, Aerospace professor; Dr. John Lundberg, Aerospace professor; Mr. Srinivas Bettadpur, Aerospace graduate student; and Mr. Elfego Pinon, Aerospace graduate student.

We would especially like to thank Dr. George Botbyl and Mr. Tony Economopoulos for their direction and guidance through the course of this design.

Executive Summary

Introduction

With the downturn of the world economy, the priority of unmanned exploration of the solar system has been lowered. Instead of foregoing all missions to our neighbors in the solar system, a new philosophy of exploration mission design has evolved to insure the continued exploration of the solar system. The "Discovery-class" design philosophy uses a low cost, limited mission, available technology spacecraft instead of the previous "Voyager-class" design philosophy that uses a "do-everything at any cost" spacecraft. The "Voyager-class" philosophy is no longer feasible. The Percival Mission to Mars has been proposed by Ares Industries as one of the new "Discovery-class" of exploration missions. The spacecraft will be christened Percival in honor of American astronomer Percival Lowell who proposed the existence of life on Mars in the early twentieth century.

The main purpose of the Percival mission to Mars is to collect and relay scientific data to Earth suitable for designing future manned and unmanned missions to Mars. The measurements and observations made by Percival will help future mission designers to choose among landing sites based on the feasibility and scientific interest of the sites. The primary measurements conducted by the Percival mission include gravity field determination, surface and atmospheric composition, sub-surface soil composition, sub-surface seismic activity, surface weather patterns, and surface imaging. These measurements will be taken from the orbiting Percival spacecraft and from surface penetrators deployed from Mars orbit.

Percival has been designed as a follow-up mission to the Mars Observer (MO) spacecraft that is currently in route to Mars. As a follow-up mission, it will augment the Mars Observer mission by improving the gravity field map created by MO and by supporting the Visual and Infrared Mapping Spectrometer (VIMS), which was originally planned for the Mars Observer mission. In addition, images and data taken by MO will be used to determine the desired impact sites for the three surface penetrators included within the Percival mission.

As a secondary mission, Percival will support the Mars Balloon Relay (MBR) communications system, similar to the one used on Mars Observer. This system is a separate communications package directed towards the surface of Mars to receive and transmit data from surface landers. During the science

phase of the Percival mission, this system will be used for data relay between the surface penetrators and Earth. After the completion of the science phase of the mission, the MBR will be used to support future Mars landers.

The Percival mission scenario consists of the following elements:

- Launch using modified Delta-class launcher.
- Use a broken-plane Hohmann transfer trajectory between Earth and Mars.
- Insert into a low altitude, circular, sun-synchronous Mars orbit.
- Determine gravity field using gravity gradiometer and Doppler-shift measurements as a backup.
- Release each penetrator individually from Percival in Mars orbit.
- Use the Mars Balloon Relay communications system for data relay from surface penetrators and future surface missions.
- Support both real-time and store-and-forward data transmission to Earth.
- Conduct scientific measurements for approximately 1-2 Martian years.

The design work for the Percival Mission to Mars has been divided among four technical areas: Orbits and Propulsion System, Surface Penetrators, Gravity and Science Instruments, and Spacecraft Structure and Systems. This overview summarizes the results for each of the technical areas followed by a design cost analysis and recommendations for future analyses.

Orbits and Propulsion System

The main objective of the orbits and propulsion group was to develop the best combination of launch system and transfer trajectory that would maximize the allowable mass in Martian orbit. The design of the final Mars orbit was designed to accommodate the gradiometer, the VIMS, and the relay communications packages. The spacecraft propulsion system was designed to provide transfer trajectory corrections, Mars orbit insertion, and end-of-mission boost burns.

The choice of launch system and the design of the transfer trajectory was heavily impacted by the low cost objective of the Percival mission and the Delta-class launch vehicle constraint stated in the Request For Proposal. The Delta

launch system is one of the less expensive launch systems, but it is also one of the lower performance vehicles among those capable of supporting an interplanetary payload. To maximize the amount of mass that can be placed into a Martian transfer trajectory, a Delta 7925 with an additional upper stage motor has been chosen. The first two stages of the Delta will place the boost stages and the spacecraft into Earth orbit, while the two Star-48B motors will provide the thrust for the Mars transfer injection burn.

To compromise between minimal energy transfer and time of flight, a broken-plane Hohmann transfer, shown in Figure 2.3, was chosen. This trajectory requires a 3576 m/s ΔV , provided by the Star 48B's, for transfer insertion. The plane change burn is performed at a true anomaly of 90°, requiring a 258 m/s ΔV to change the orbital plane by 0.53°. Course corrections will also be made during this burn. The Mars insertion burn will require a 2178 m/s ΔV by the spacecraft propulsion system. The time of flight will be approximately 11 months.

The design of the final Mars orbit was driven by the instrument packages onboard Percival. To increase the accuracy and precision of the gradiometer data, a low-altitude (179.4 km), circular orbit was chosen. To increase the groundtrack coverage of Mars, a high inclination orbit was necessary. A sun-synchronous orbit was chosen for this reason as well as to reduce thermal variations on the spacecraft. The sun-synchronous orbit also minimizes the pointing requirements of the high-gain antenna used to communicate with Earth. The period of the Martian orbit will be 108 minutes. The groundtrack for this orbit allows for communication with each penetrator every two to three days and allows for a complete VIMS mapping cycle in 82 days.

Percival's propulsion system is designed to provide the plane change burn, course corrections, Mars orbit insertion, and end-of-mission orbit boost. These maneuvers will require a ΔV of 2436 m/s. The resulting propulsion system will have approximately 60 kg of hardware mass and 730 kg of propellant mass.

Surface Penetrators

The surface penetrators group was tasked to design the penetrator system, which includes deployment methods, deceleration methods, impact and stress analysis, structural design, subsystem design, and scientific instrumentation of the penetrators. The purpose of the penetrator system is to provide scientific data from the surface and sub-surface of Mars as an aid to

designing future manned and unmanned missions. The data returned by the penetrators will help determine the feasibility of a landing site and the scientific interest of a site.

Each of the three penetrators will be deployed separately from Martian orbit and impact at a different location on the Martian surface. The deployment and deceleration system uses a spring for the initial separation from Percival, a 500 m/s ΔV deorbit motor for entry, and a 1.14 m diameter drag chute for deceleration and stability through the atmosphere. The transfer from Mars orbit to impact takes approximately 4.5 minutes and results in a 235 m/s impact velocity.

Upon impact the forebody and afterbody of the penetrator separate as shown in Figure 3.1. The umbilical cord connecting the two sections of the penetrator contains power and communications lines. Both hard and soft soil models were used to analyze the impact. The forebody must penetrate deep enough to isolate the seismic instruments from surface wind disturbances, but must not separate from the afterbody farther than the umbilical cord will allow. The penetration of the afterbody must be minimized so that the communications and surface instruments will remain on the surface. The results of the penetration analysis are summarized in Table 3.2.

Each penetrator contains instrumentation that will carry out four scientific objectives: planetary science, imaging, soil analysis, and meteorology. Planetary science is the determination of the interior structure of Mars. This involves the study of the surface structure, global seismology, and the magnetic field of the planet using a seismometer and a magnetometer. Imaging systems on the penetrators will provide information on the geology of the Martian surface. Two imaging systems will be on each penetrator: a descent imager located on the nose of the penetrator and a panoramic imaging system located in the top of the afterbody. Soil analysis is the study of the chemical composition, water content, and physical properties of the subsurface soil. The physical properties of the soil include the subsurface temperature and conductivity. A meteorology package containing four distinct instruments will measure the temperature, pressure, humidity, and wind speed and direction of the local atmosphere.

The necessary subsystems for each penetrator are power, communications, and thermal control. The power subsystem is composed of a 0.5 W Radioisotope Thermoelectric Generator (RTG) and a 20 W Nickel-hydrogen battery. The RTG handles all continuous power requirements and

recharges the battery. The battery will provide for peak power requirements, such as transmission of data to Percival. This type of power system provides for a penetrator with an operating life of one year. The communications system uses a helix antenna on the penetrator afterbody for receiving and transmitting data. The thermal system uses thermal blankets and excess heat from the RTG to keep the battery in the proper temperature range. The remainder of the excess heat is transferred to the soil using a heat pipe. Figure 3.3 shows a layout of the penetrator subsystems and instrumentation. Table 3.6 shows a breakdown of the mass and power requirements of the penetrator.

Gravity and Science Instruments

Two of the main objectives of the Percival mission are to augment and improve the gravity field mapping being done by MO and to serve as a support platform for scientific instrumentation that was originally planned for MO. The gravity and science instruments group chose the instruments to accomplish these objectives and developed the constraints that the instruments placed on the Percival spacecraft.

Mars Observer will be using radioscience techniques (Doppler shift measurements) to carry out gravity mapping of Mars. Percival will improve upon the accuracy of the MO gravity map by using a two-axis gravity gradiometer, sensitive in the radial and transverse directions. This instrument uses highly sensitive accelerometers to measure the local gravity field. It is expected that an accuracy of 1 Eotvos will be obtained by using the gradiometer without cryogenic cooling. Since gradiometers have never been used in space, Percival will also have the capability to support radioscience techniques. Doppler shift measurements will still augment the gravity map created by MO, though the accuracy of the map will not be improved.

To achieve the desired accuracy and sensitivity of the gravity field map, mechanical vibrations and accelerations generated by the spacecraft must be eliminated or minimized. The gradiometer also requires that attitude position and rates be known very precisely. Table 4.1 summarizes the requirements placed on the GN&C system. While attitude maneuvers are being conducted, the gradiometer will not make gravity field measurements.

The Visual and Infrared Mapping Spectrometer (VIMS) will also be flown on Percival. This instrument, originally designed for MO, will determine the

composition of the Martian atmosphere and surface. The VIMS mapping mission requires the Percival spacecraft to maintain a nadir orientation. This type of orientation requires the spacecraft to maintain a constant revolution rate of one revolution per orbit. This rotation rate is not high enough to significantly affect the gradiometer measurements. A more sensitive, cryogenically-cooled gradiometer would need to take the rotational acceleration terms into account. With an orbital altitude of 179.4 km, one VIMS mapping cycle of Mars will take 82 days.

Spacecraft Structure and Subsystems

The Spacecraft group was responsible for designing the basic structure and the subsystems of the Percival spacecraft. To eliminate the need for a complete redesign of the spacecraft bus, the Percival spacecraft bus was based on a scaled down version of the Planetary Observer bus used for the MO mission. Systems design was done for the communications, power, thermal, and GN&C subsystems. A schematic of the spacecraft is shown in Figure 5.1. A summary of the mass and power requirements of each spacecraft system is shown in Table 5.1.

The communications system consists of a high-gain antenna and a backup low-gain antenna for communication with Earth. The high-gain antenna will transmit at a frequency of 8.4 GHz with a data rate of 150 kbps. Since Percival will not be able to transmit at all times, the capability to store data in addition to real-time transmission will be used. Ares Industries expects that Percival will receive an allocation of Deep Space Network (DSN) time roughly equivalent to the 8 hours per day that MO receives currently. During the 8 hour period, Percival would be able to transmit approximately 1622 megabits of data.

For communications with the surface of Mars, Percival will use the Mars Balloon Relay (MBR) communications system currently used on MO. This system consists of a low-gain antenna pointed towards the surface of Mars. The antenna will transmit at 401 MHz and receive at 406 MHz with a data rate of 8 kbs. This communications system will support the surface penetrators during the science phase of the Percival mission. Beyond the science phase, the MBR system will support other future surface missions.

An RTG and battery combination was chosen to provide power for the Percival spacecraft. The RTG was chosen for its good mass to power rating (5.4 W/kg) and for its ability to generate power without repointing as solar panels are required to do. The battery would be used to provide power during peak power

consumption phases of the mission. Today's RTGs use Plutonium 238 as the radioactive isotope. This isotope is not commonly available, making the RTG very expensive. A less expensive alternative would be to make RTGs that utilize a more readily available isotope, such as Strontium 90. This isotope is a common daughter isotope in all nuclear reactors. In the past, Strontium 90 has been used for SNAP reactors on spacecraft.

The thermal control methods will be based primarily on passive methods to reduce the mechanical noise produced by the system. Passive methods of thermal control will include thermal blankets and surface coatings. The active thermal control methods used will include freon radiators and heaters.

The Guidance, Navigation, and Control system consists of sensors and thrusters to determine and control the spacecraft's position, velocity, and attitude. The GN&C system is designed to be completely autonomous with the capability of ground override. Attitude and position determination will be done using a sun sensor and a fixed-head star tracker. Rate determination will be done using a ring laser gyro. The control system will use 24 reaction control jets divided among two independent systems. One system will use hot gas, while the other will use cold gas. The cold gas thrusters will allow the spacecraft to be controlled more precisely than the hot gas thrusters will allow.

Recommendations

As designed, the Percival spacecraft is not capable of supporting all mission objectives. The constraint of the Delta launch vehicle has limited the allowable mass of the spacecraft to 460 kg dry mass at Mars. This is 75 kg higher than the mass estimate for Percival of 535 kg. To come within the mass budget, one or more mission objectives may have to be eliminated or a higher performance launch vehicle must be used. It may also be possible to take advantage of larger GEMs (Graphite-Epoxy Motors) to provide the additional boost, if they become available in the future.

A preliminary estimate of the development and production cost for the Percival mission has shown that, as designed, Percival exceeds the desired "Discovery-class" budget of \$150 million. The current estimate of \$270 million includes the development, production, and launch costs for the Percival mission. The cost estimate does not include program costs, operation costs, or other long term management costs. Ares Industries has concluded that the numerous mission objectives of the Percival mission make it unsuitable for a true Discovery-

class mission. If a Discovery-class mission is required, one of the three major scientific objectives, gradiometer, penetrator, or the VIMS, should be chosen as the single, primary mission objective.

To design the Percival Mission to Mars beyond the preliminary design phase, detailed design must be done for all portions of the project. The following issues must also be considered. For the propulsion system, the type of propellant must be chosen to give a more precise estimate of the fuel mass required. The penetrator system requires the accuracy of the penetrator targeting to be determined in addition to the effects of winds on the entry trajectory and attitude of the penetrator. Also, the susceptibility of the penetrator structure to failure during an oblique impact must also be considered. The feasibility of increasing the data rate of the Mars Balloon Relay should be determined. For the spacecraft power system, the feasibility of using a Strontium 90 RTG should be further analyzed. The GN&C system of Percival should be analyzed in more detail to determine if it satisfies the position and rate determination and control requirements defined by the gradiometer.

Table of Contents

Executive Summary	i
Table of Contents	ix
List of Figures	xii
List of Tables	xiii
1.0 Overview.....	1
1.1 Mission Objectives	1
1.2 Mission Scenario	1
1.3 Design Drivers	2
1.4 Report Overview	2
2.0 Orbits and Propulsion System Design.....	3
2.1 Launch Vehicle	4
2.2 Earth-Mars Transfer Trajectory.....	5
2.2.1 Hohmann Transfer	5
2.2.2 Lambert Targeting	7
2.2.3 Gravity Assist Trajectories	8
2.2.4 Baseline Trajectory	9
2.3 Final Mars Orbit	10
2.4 Orbital Mission Scenario	13
2.5 Spacecraft Propulsion System.....	13
2.6 Summary	14
3.0 Surface Penetrator Design	15
3.1 Deployment and Atmospheric Entry	16
3.2 Penetrator Structure and Emplacement	17
3.2.1 Impact Conditions	17
3.2.2 Penetrator Emplacement	17
3.2.3 Structural Design	19
3.3 Scientific Instruments.....	21
3.3.1 Planetary Science Instruments	21
3.3.2 Soil Analysis Instruments	22
3.3.3 Imaging Systems	22
3.3.4 Atmospheric Measurements	24
3.3.5 Instrumentation Layout	24
3.4 Penetrator Subsystems	25
3.5 Low-Cost Alternative.....	27

3.6 Summary	27
4.0 Gravity Field Mapping and Science Instruments	29
4.1 Gravity Determination Techniques	29
4.1.1 Gravity Gradiometry	29
4.1.2 Radioscience Gravity Mapping	30
4.1.3 RADAR Tracking Gravity Mapping	31
4.2 Spacecraft Interface	31
4.2.1 Attitude Determination	31
4.2.2 Spacecraft Orientation	32
4.2.3 Subsystem Implications	33
4.2.4 Mass, Volume, and Power Requirements.....	34
4.3 Scientific Instruments.....	34
4.4 Summary	35
5.0 Spacecraft Structure and Subsystems Design	37
5.1 Spacecraft Structure	37
5.2 Power Subsystem.....	37
5.3 Thermal Control Subsystems	39
5.4 Communications Subsystem	39
5.5 Guidance, Navigation, and Control	40
5.5.1 Guidance	41
5.5.2 Navigation	41
5.5.3 Control	41
5.6 Summary	42
6.0 Management Structure and Cost Summary	44
6.1 Management Structure	44
6.2 Cost Summary	45
6.2.1 Personnel Cost	45
6.2.2 Material Cost.....	45
6.2.3 Preliminary Cost Estimate.....	45
7.0 Conclusions	47
8.0 Recommendations.....	49
9.0 References	50
10.0 Bibliography.....	52

Appendices

Appendix A: Penetrator Emplacement and Stress Analysis Method

Appendix B: Trajectory Design Code and Resulting Data

Appendix C: Cost Summaries

List of Figures

Figure 2.1	Delta 7925 Launch Vehicle Schematic.	4
Figure 2.2	Hohmann Transfer from Earth to Mars.	5
Figure 2.3	Hohmann Transfer with Broken Plane Maneuver.	6
Figure 2.4	Lambert Targeting Trajectory.	7
Figure 2.5	Earth Departure Geometry.	9
Figure 2.6	Mars Approach Geometry.	10
Figure 2.7	Final Mars Orbit.	11
Figure 2.8	Groundtracks of Martian Orbit.	12
Figure 3.1	Surface Penetrator Deployment.	15
Figure 3.2	Penetrator Dimensions.	20
Figure 3.3	Schematic of Penetrator Scientific Instrument and Subsystems Layout.	25
Figure 4.1	Dual Axis Accelerometer Preliminary Design (9).	30
Figure 4.2	Inertial Reference Frame.	33
Figure 4.3	Visible and Infrared Mapping Spectrometer Schematic (14).	35
Figure 5.1	Scaled Down Version of Planetary Observer Spacecraft.	38
Figure 5.2	Dual Attitude Control System for Percival Spacecraft.	42
Figure 6.1	Percival Design Team Organizational Structure	44
Figure 6.2	Personnel Cost Status	46

List of Tables

Table 2.1 Comparison of Three Hohmann Transfer Opportunities.	6
Table 2.2 Lambert Targeting Options.	8
Table 3.1 Drag Chute Sizing	16
Table 3.2 Penetration Analysis Input Quantities.	18
Table 3.3 Penetrator Performance.	18
Table 3.4 Penetrator Dimensions.	19
Table 3.5 Maximum Stress in Penetrator Walls.	20
Table 3.6 Critical Stresses for Penetrator Loading.	20
Table 3.7 Mass, power, and data rate requirements for the planetary science	22
Table 3.8 Mass, power, and data rate requirements for the soil analysis	23
Table 3.9 Mass, power, and data rate requirements for the penetrator	23
Table 3.10 Mass, power, and data rate requirements for the meteorology	24
Table 3.11 Penetrator Mass and Power Summary.	28
Table 4.1 Gradiometer Attitude Control Constraints.	32
Table 4.2 Mass, Volume, and Power Requirements of Gradiometer and Science instruments.	34
Table 5.1 Mass and Power Requirements for Percival.	43

1.0 Overview

This report describes the design work done by Ares Industries to complete the preliminary design of the Percival spacecraft. This design was done in response to the Request for Proposal (RFP) for an unmanned Martian gravity mapper.

1.1 Mission Objectives

The following mission objectives, taken from the RFP, were the basis of the Percival mission design:

- To augment and improve the Martian gravity field determination being carried out by Mars Observer.
- To deploy a set of instrumented penetrators in selected regions of Mars as a precursor to future manned and unmanned Mars missions.
- To relay penetrator and gravity field data back to Earth
- To provide a platform for scientific instrumentation cut from the Mars Observer mission due to funding cutbacks.
- Low cost, available technology design.

The last mission objective was not explicitly stated in the RFP, but was implied through the specification of a Delta class launcher.

1.2 Mission Scenario

The above objectives are met by the current mission scenario, listed below.

- Launch using modified Delta-class launcher.
- Use a broken-plane Hohmann transfer trajectory between Earth and Mars.
- Insert into a low altitude, circular, sun-synchronous Mars orbit.
- Determine Mars gravity field using gravity gradiometer and Doppler- shift measurements as a backup.
- Release each penetrator individually from Percival in Mars orbit.

- Use the “Mars Balloon Relay” communications system for data relay from surface penetrators and future surface missions.
- Support both real-time and store-and-forward data transmission to Earth.
- Conduct scientific measurements for approximately 1-2 Martian years.

1.3 Design Drivers

The design of the Percival spacecraft was driven by the specification of the Delta-class launcher for the mission and the “Discovery-class” design philosophy (1). The Delta-class launcher necessitates a low mass due to the limited performance launchers. The “Discovery-class” design philosophy specifies a low-cost, limited objective, and available technology design. This design philosophy has developed in response to the limited funding that is now available to exploration spacecraft. Instead of foregoing all space exploration missions, “Discovery-class” missions may be used to continue the unmanned exploration of the solar system.

1.4 Report Overview

The technical work done by Ares Industries has been divided among four technical areas: Orbits and Propulsion System Design, Surface Penetrator Design, Gravity Field Mapping and Science Instruments, and Spacecraft and Subsystems Design. The remainder of this report consists of descriptions of the technical work done by each element, a brief section on management and project costs, and the conclusions and recommendations of the Percival design study.

2.0 Orbits and Propulsion System Design

The primary considerations for selecting an orbital trajectory and propulsion system are the following:

- Design must accommodate the mass of the entire spacecraft
- Trajectories must minimize the total ΔV required in order to maximize the available mass
- Mission scenario should result in a Mars orbit that best enables Percival to carry out its objectives

The basic mission scenario as outlined in the request for proposal (RFP) consists of a near-Hohmann trajectory to Mars initiated by a Delta class launcher. The near-Hohmann transfer enables a larger mass to be placed in orbit than most other trajectories. Ares Industries looked into two other types of trajectories: Lambert targeting trajectories and gravity assist trajectories. The Delta class launcher was specified in the RFP because of its low cost. The RFP further specified a final Mars orbit that would trail Mars Observer or be in a high-low configuration with it. However, after consideration of the projected lifetime of Mars Observer and the operational independence inherent in the spacecraft instruments onboard Percival, Ares Industries has decided that this constraint is unnecessary, and will establish an independent orbit.

The considerations affecting the choice for the final Mars orbit are outlined below:

- Low altitude, for sensitivity of measurements
- Near circular, for uniformity of measurements
- Sun-synchronous, for minimizing thermal variations

The Percival spacecraft will use a chemical propulsion system. This system will be used to provide the thrust for the plane change at the broken plane maneuver and for the Mars Orbit Insertion burn.

2.1 Launch Vehicle

The Delta 7925 with an additional Star 48B upper stage has been selected as Percival's launch vehicle. The 7925 and its various configurations are the only commercial Delta launch vehicles in production (2). The addition of a second upper stage allows a greater spacecraft mass to be placed into orbit than does a single upper stage; however, the highest allowable spacecraft mass, 1187 kilograms, is achieved when the second Star 48B has only 1587 kg of fuel loaded on it, about three-fourths of its standard amount. Fuel offloading for the Star series of motors is a routine process and should pose no problem (3). The Delta's full launching power was used in creating this configuration, so the two upper stage/spacecraft combination are placed into a low, 185 km circular orbit about the Earth, into which the Delta can lift the most payload mass. From low Earth orbit, the two upper stages successively burn to inject Percival into its transfer trajectory.

The Delta 7925 can not lift as much mass into orbit as some other commercially available launch vehicles, but cost is a major constraint in the Percival mission. The 7925 is a good compromise between performance and cost. Figure 2.1 shows a schematic of the Delta 7925.



Figure 2.1 Delta 7925 Launch Vehicle Schematic.

2.2 Earth-Mars Transfer Trajectory

Three types of trajectories were considered for Percival's Earth-Mars trajectory. These three trajectories are:

1. Hohmann transfer with broken plane maneuver (BPM) at $v=90^\circ$
2. Lambert-targeted trajectories
3. Gravity assist

2.2.1 Hohmann Transfer

Hohmann transfer trajectories utilize a minimum ΔV transfer by traveling on the smallest ellipse connecting the original and final orbits. Figure 2.2 illustrates the Hohmann transfer trajectory.

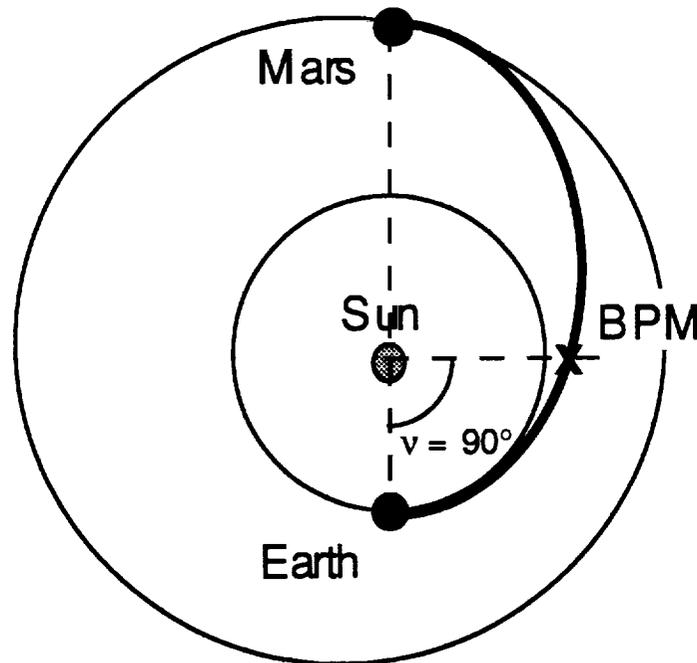

Figure 2.2 Hohmann Transfer from Earth to Mars.

The transfer to Mars, however, requires a plane change. A broken plane maneuver performed at a true anomaly of 90° along the Hohmann trajectory will require the smallest amount of ΔV . The amount of plane change required in such a case is the target's ecliptic latitude, β (4). The following figure (Figure 2.3) illustrates a Hohmann transfer with a broken plane maneuver.

Hohmann transfer trajectories from Earth to Mars have launch opportunities that repeat every 2.1 years. Table 2.1 gives the allowable masses and ΔV 's for the next three launch opportunities. The launch opportunity in 1996 is the optimum launch date of the three, allowing a spacecraft dry mass of 460 kg. The calculations were made using the programs listed in Appendix A.

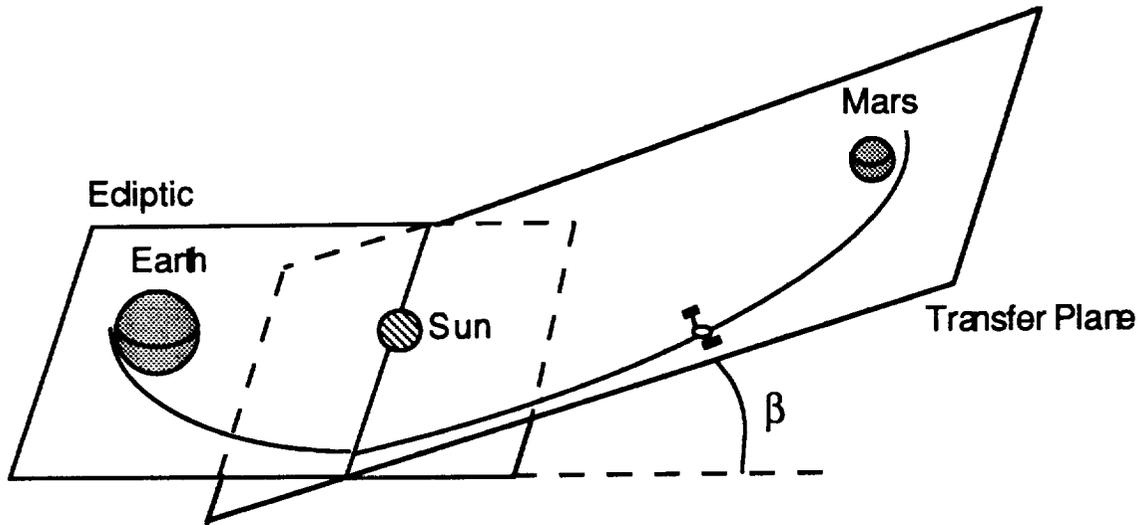

Figure 2.3 Hohmann Transfer with Broken Plane Maneuver.

Table 2.1 Comparison of Three Hohmann Transfer Opportunities.

	November 28, 1996	January 5, 1999	March 8, 2001
Time of Flight	254 days	241 days	236 days
Total ΔV	6012 m/s	6629 m/s	6707 m/s
Percival ΔV	2436 m/s	3146 m/s	3250 m/s
Total Spacecraft mass	1187 kg	1235 kg	1249 kg
Approximate dry mass	460 kg	409 kg	398 kg

2.2.2 Lambert Targeting

Lambert Targeting does not require a spacecraft to follow just one highly-defined trajectory like the Hohmann transfer. Therefore, a Lambert targeting solution can be found for more flexible launch windows. Initially, only Lambert targeting solutions allowing Percival to arrive when Mars is at one of its orbital nodes were considered in order to eliminate the need for a plane change. A Lambert targeting trajectory to a descending node is illustrated in Figure 2.4.

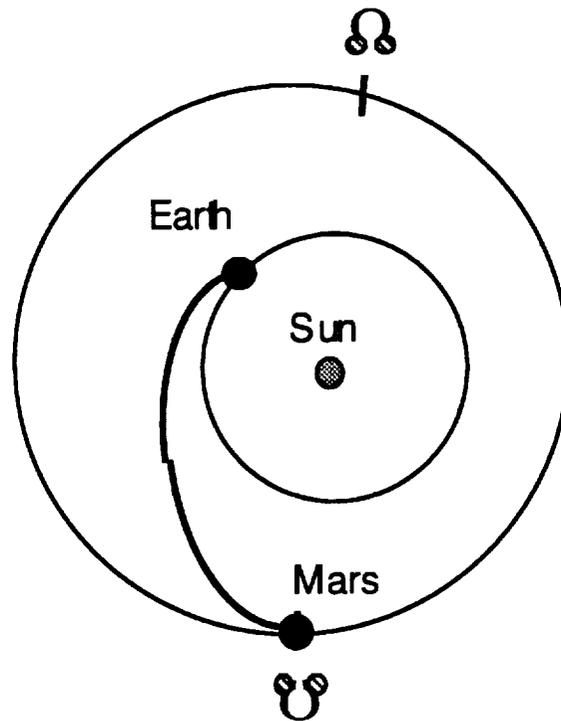

Figure 2.4 Lambert Targeting Trajectory.

Optimization of the Lambert targeting solution considers launch date, time of flight, and the required ΔV 's. The goal for this type of trajectory was again to maximize the dry mass of the spacecraft. The results of this optimization are listed in Table 2.2. As can be seen, neither solution benefits the mission more than the Hohmann trajectory; thus, no total ΔV would be lower than that of the Hohmann trajectory, and no larger spacecraft dry mass could be attained.

Table 2.2 Lambert Targeting Options.

	Minimizing MOI ΔV	Minimizing ΔV from LEO
Launch date	August 22, 1996	November 29, 1996
Time of Flight	320 days	221 days
ΔV from LEO	5460 m/s	3460 m/s
ΔV for MOI	2610 m/s	3590 m/s
Total spacecraft mass	270 kg	970 kg
Approximate dry mass	-	260 kg

note: LEO - Low Earth Orbit
MOI - Mars Orbit Insertion

More general Lambert targeting solutions were also investigated. These were Lambert trajectories with a Broken Plane Maneuver performed 90° before intercepting Mars. As for the Hohmann trajectory with BPM, performing the BPM on a Lambert trajectory 90° before target intercept also requires the least ΔV (4). The characteristics of the Lambert solutions calculated were those with launch dates on each of the 800 consecutive days beginning in mid-November 1996, and having times-of-flight from 200 to 400 days. The launch dates were chosen to encompass an entire Earth-Mars synodic period, and also, combined with the relatively short times-of flight chosen for investigation, to allow for Percival's arrival at Mars in a timely manner to allow it to carry out one of its important functions after its primary science missions have been completed--to provide a communications link to Earth for future missions to Mars. The results of all of these calculations are too lengthy to display here, but the important result is that none of the solutions provided a lower total ΔV or a higher dry mass than did the Hohmann trajectory described above. Therefore, the broken-plane Hohmann trajectory is preferred over the Lambert trajectories.

2.2.3 Gravity Assist Trajectories

Gravity assist trajectories utilize the gravitational attraction of a planet or other large mass to provide a positive ΔV to the spacecraft during a flyby with the planet. The best option for a gravity assist trajectory from Earth to Mars would utilize Venus, which is closer to Earth and Mars than Jupiter. But the additional weight acquired through radiation protection does not make this option appealing. Since Percival is already over budget in terms of mass, any added weight can not

be allowed. Also, the longer times of flight would inhibit the types of instruments that Percival could carry. Therefore, gravity assist is not a viable option.

2.2.4 Baseline Trajectory

After consideration of all of the options, the baseline trajectory for the Percival mission to Mars was chosen to be the Hohmann transfer with BPM. The optimum launch date is November 28, 1996. The geometry for Earth departure is shown in Figure 2.5. All relevant numbers are given in Appendix A.

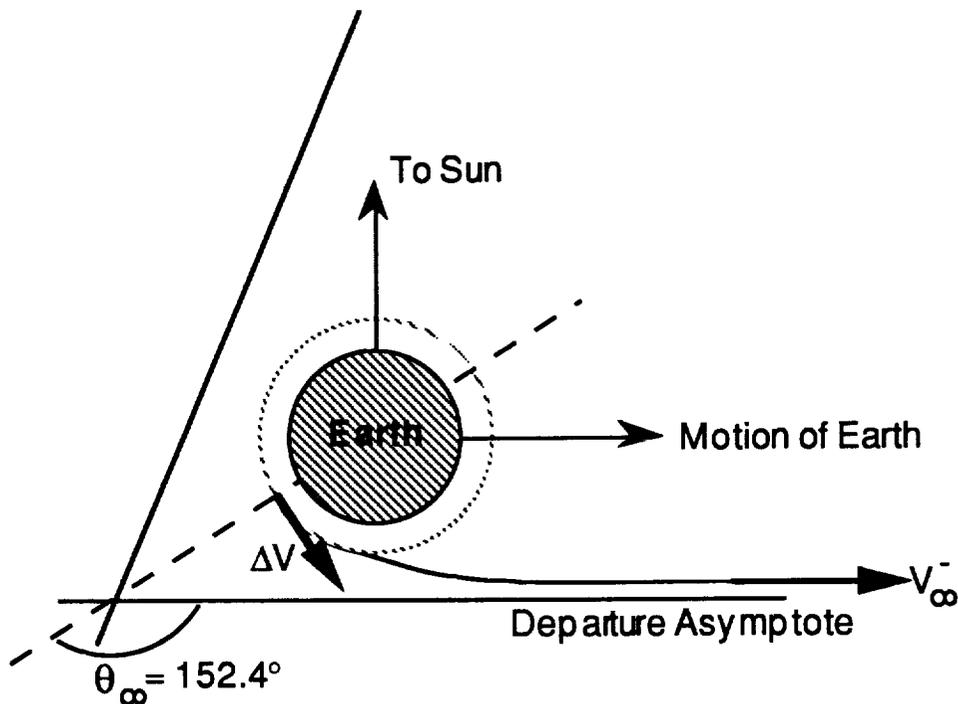

Figure 2.5 Earth Departure Geometry.

One reason for the appeal of the 1996 opportunity is the small plane change required for it compared to later opportunities. The plane change angle is only 0.53° , which translates into a relatively small ΔV of 258 m/s. Thirty five extra kilograms of propellant have been added to Percival to accommodate a total of about 85 m/s of trajectory corrections. This additional propellant should be sufficient for any necessary corrections considering that this is approximately the amount allowed for Mars Observer, a much larger spacecraft than Percival

(5). After a time of flight of 254 days, Percival should arrive at Mars on August 9, 1997. The approach geometry is shown in Figure 2.6. Again, all relevant numbers are given in Appendix A.

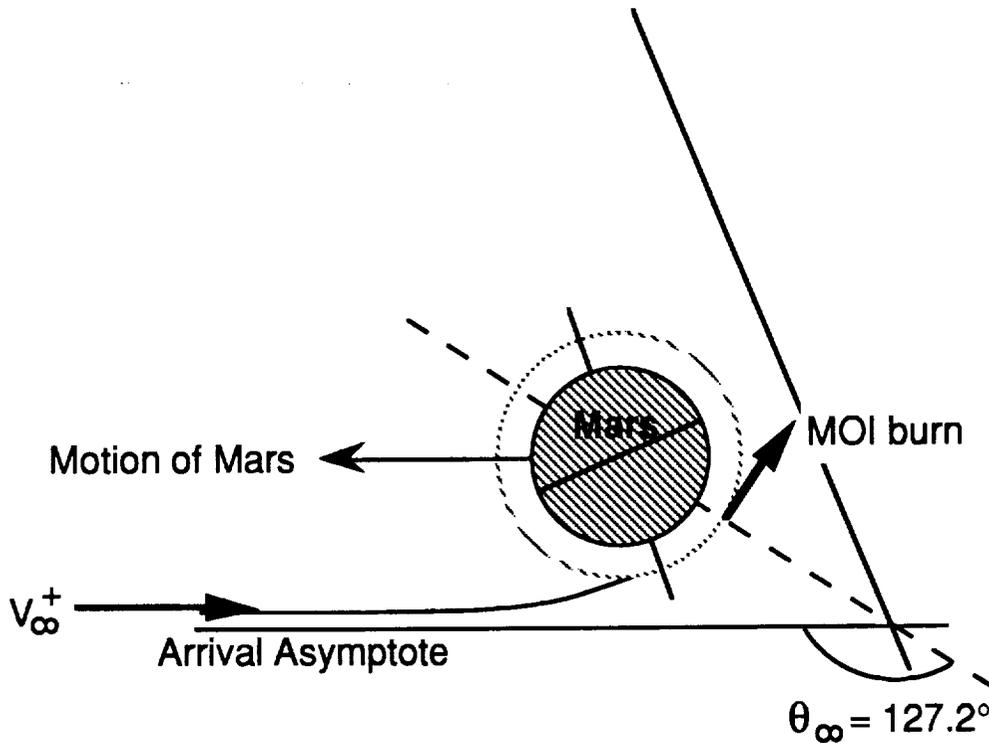

Figure 2.6 Mars Approach Geometry.

2.3 Final Mars Orbit

For insertion into the final Mars orbit, aerobraking was considered as a propellant-saving option. However, the atmosphere of Mars is very thin (5), so that appreciable results from an aerobraking maneuver could not be obtained without performing a dangerously low passage above the Martian surface. Therefore, this option was discounted, and Mars orbit insertion will be performed by Percival's thrusters so as to directly enter the final Mars orbit.

The final Mars orbit itself will be a circular, sun-synchronous orbit. A sun-synchronous orbit was chosen because it minimizes thermal variations on the scientific instruments, primarily the gradiometer, which could affect their measurements. A low-altitude orbit, 179.4 km, was selected because it allows

more accurate gravity readings and the atmosphere is still thin enough at that altitude that the orbit will not decay because of drag (6). The actual altitude was chosen because it allows communications with the penetrators every two to three Martian days, and also allows an orderly coverage of the Martian surface by the VIMS that results in a complete mapping cycle every 82 Martian days. Figure 2.7 summarizes the final Martian orbit. A schematic representation of the groundtracks produced by the orbit design is shown in Figure 2.8.

As shown in Figure 2.7, the orbital plane is roughly perpendicular to the direction of the sun, and will remain in this configuration for the duration of the mission. Therefore, the pointing requirements for Percival's Earth-facing antenna only encompass a limited range of angles, minimizing repositioning demands on the antenna which produce mechanical noise disruptive to the gradiometer.

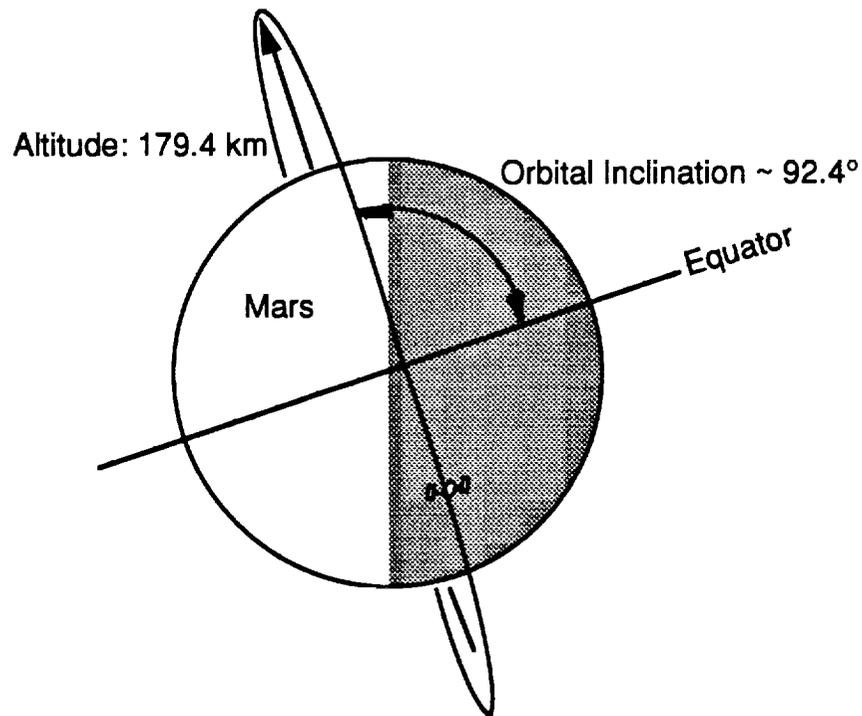

Circular, sun-synchronous orbit
 Altitude: 179.4 km
 Inclination: 92.36°
 Period: 108.2 minutes

Figure 2.7 Final Mars Orbit.

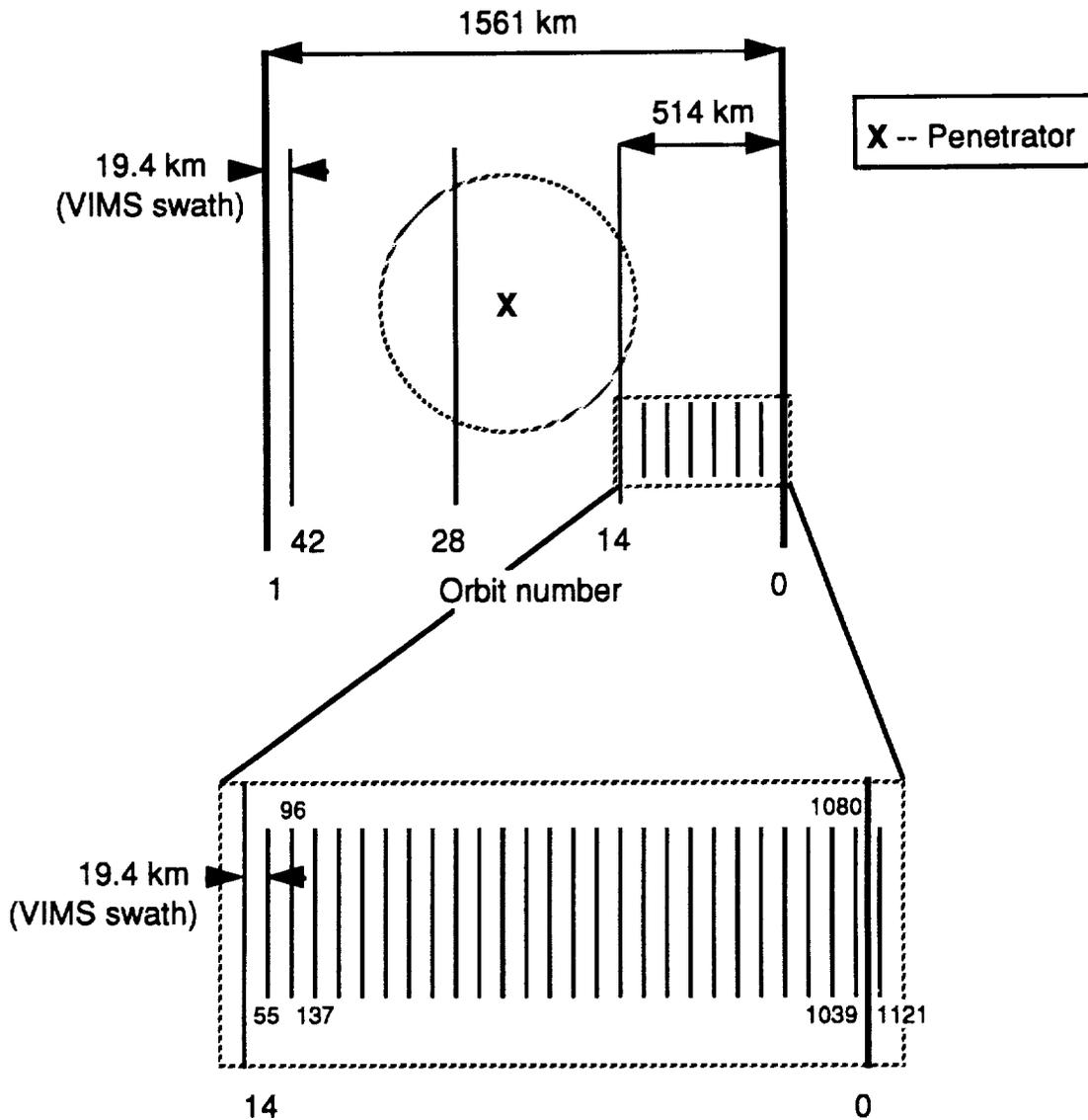

Figure 2.8 Groundtracks of Martian Orbit.

Upon completion of its one to two year mission, Percival will boost itself into a permanent 375 km circular orbit above the Martian surface. This is to obey international contamination requirements of ensuring a less-than 0.0001 probability that the spacecraft will impact Mars before January 1, 2009, and a less-than 0.05 probability that an impact will occur between January 1, 2009, and January 1, 2039. To satisfy these requirements, an orbit with a semi-major axis of at least 3767.2 km is required (5). A 375 km circular orbit satisfies this

requirement. An orbit of this altitude will also provide better coverage of Mars and better access to Earth for future missions that may utilize the Mars Balloon Relay on Percival for communications.

2.4 Orbital Mission Scenario

To summarize, the scenario for the Earth to Mars trajectory is outlined below.

Launch

- Launch optimally on November 28, 1996
- Launch on Delta 7925 with second, partially-fueled Star 48B upper stage
- Upper stages and spacecraft placed in 185 km circular orbit about Earth
- Total spacecraft mass of 1187 kg

Hohmann Transfer with Broken Plane Maneuver

- Hohmann transfer with BPM at $v=90^\circ$
- Time of flight - 254 days
- ΔV required to initiate Hohmann transfer - 3576 m/s
- Plane change required of 0.53°
- ΔV required for plane change - 258 m/s

Arrival at Mars

- Arrival date - August 9, 1997
- Direct insertion to 179.4 km circular orbit
- ΔV required for insertion - 2178 m/s
- Spacecraft dry mass - 460 kg
- Boost Percival at end of mission to 375 km circular orbit
- ΔV required - 90.9 m/s

2.5 Spacecraft Propulsion System

The primary option being considered for the propulsion system is chemical fueled thrusters because they are well tested, reliable, and low cost. The ΔV required of these thrusters is 2436 m/s. The estimated hardware mass is 60 kg and the estimated propellant mass is 730 kg.

2.6 Summary

In order to fulfill all of the requirements and considerations of the orbits and propulsion design of the Percival mission, many options were considered and some assumptions were made. The mission scenario and final Mars orbit have been chosen so as to minimize the ΔV 's required to execute the mission. This is primarily to maximize the allowable spacecraft mass at Mars, but also to help lower the cost of the mission. The addition of a second upper stage on the Delta to allow more mass will result in a higher cost and more design effort, but the increased cost should be small compared to the total cost of the launch system. Furthermore, having a more powerful upper stage system facilitates the design of a mission that will accommodate all of the proposed objectives. Nevertheless, other options for third stages and transfer trajectories should be investigated in an attempt to further improve the efficiency of the mission and to increase its scientific potential.

3.0 Surface Penetrator Design

One of Percival's primary objectives is to land surface penetrators on Mars in order to deploy instruments on and below the surface. The penetrator instruments will be used to acquire scientific data about Mars in order to advance planetary science and to provide a precursor for future unmanned and manned missions to Mars. The impact sites for the penetrators will be selected on the basis of scientific value and potential for future manned missions.

The basic penetrator mission scenario consists of the following stages:

- 1) Release from Percival
- 2) Deorbit and descent to the Martian surface
- 3) Impact with surface
- 4) Relay of scientific data back to Percival and then to Earth for a mission lifetime of one Earth year

Each penetrator consists of a forebody which penetrates deep into the surface and an afterbody with remains on the surface. Both the forebody and the afterbody contain scientific instruments and are connected by an umbilical cord designed to transfer data and power between the two sections. Figure 3.1 shows how the penetrator deploys upon reaching the Martian surface.

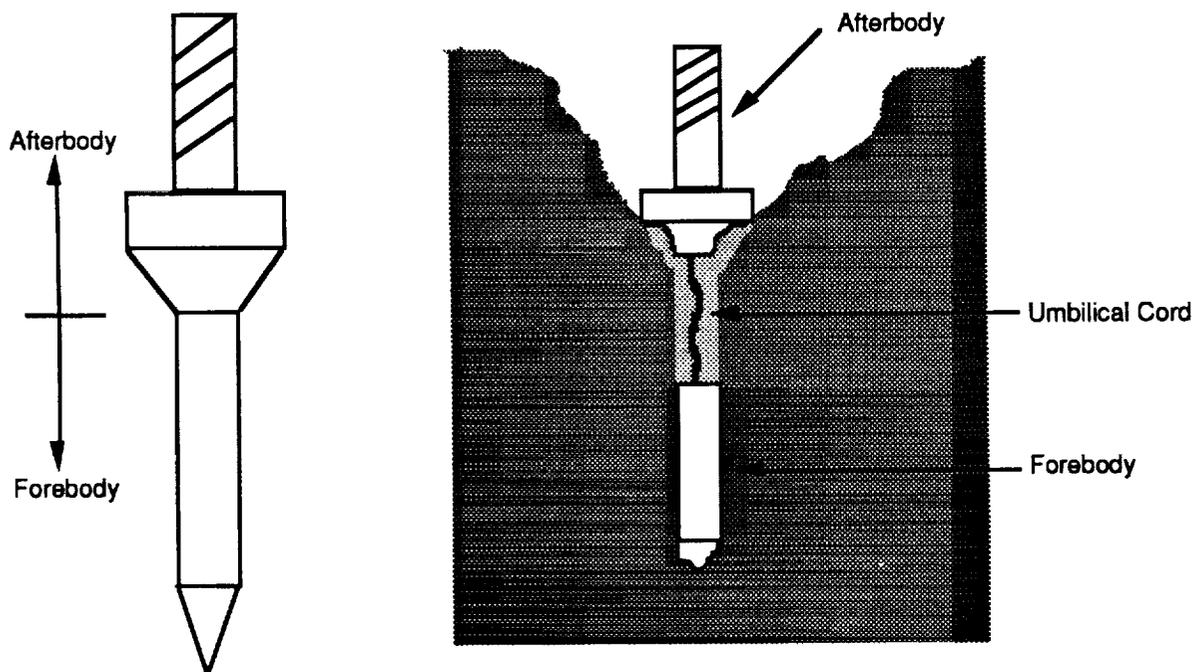

Figure 3.1 Surface Penetrator Deployment.

3.1 Deployment and Atmospheric Entry

The penetrators will be released from Mars orbit from Percival, instead of the transfer orbit specified in the Proposal. There are two reasons for this. First, release from Mars orbit lowers the impact velocity that the penetrator must be designed to survive. Second, the required precision in the propulsion and attitude control system is lower when the penetrators are released from the Earth-Mars transfer trajectory, which lowers the weight and complexity of the guidance and control systems.

A spring or similar device will be used to separate each penetrator from the Percival spacecraft. Once the penetrator has moved away from the Percival spacecraft, a small motor will burn to deorbit the penetrator. For preliminary calculations, a 500 m/s ΔV deorbit motor was assumed. Future analyses will consider the sizing of the deorbit motor and the descent trajectory of the penetrator.

Some form of deceleration during the descent from orbit will be necessary to reduce the impact loads on the penetrator. A solid rocket motor was chosen for deorbit and a drag chute for atmospheric deceleration. The optimum size for the drag chute was determined to be 1.14 m in diameter. The chute deploys after about 200 seconds when the penetrator reaches the tangible atmosphere. After deployment, it takes about 80 seconds for the penetrator to impact the surface. A smaller drogue chute is also deployed behind the large chute to assist in the deployment of the large chute and to increase the aerodynamic stability. Table 3.1 shows the results of preliminary drag chute sizing. The 1.14 m drag chute was chosen since it slowed the penetrator sufficiently without being too large.

Table 3.1 Drag Chute Sizing

Diameter (m)	Impact Velocity (m/s)	Time in Atmosphere (s)
1.00	304	82
1.14	234	106
1.30	180	138
1.50	135	185
1.70	105	238
2.0	76	329

3.2 Penetrator Structure and Emplacement

The structure of the penetrators must withstand the large deceleration loads that occur during impact with the surface of Mars. The structure must also protect the scientific instrumentation and penetrator subsystems from being damaged during the impact. The analysis method used for the penetrator emplacement and the structural design are taken from Mars Balloon and Surface Penetrator Study by Mark E. Johnson. This method is described in detail in Appendix B of this report. Any equations or related data not mentioned in the following text may be found in this Appendix. The results of the penetration and stress analysis for the Percival mission penetrators are given in the following sections.

3.2.1 Impact Conditions

To determine the necessary strength of the penetrator structure and the depth of penetration, the initial impact conditions must be determined. The primary concern is the impact velocity, since the penetration depth equations use impact velocity as an input. Using a 1.14 m diameter drag chutes yields a 235 m/s impact velocity.

The obliquity of the impact is also a concern. Stress analysis of the penetrators is based on a normal impact with the surface (longitudinal axis of penetrator oriented perpendicular to the surface). Any deviation from a normal impact will induce bending stresses in the penetrator structure. Future analysis will determine the oblique impact tolerance of the penetrator structure.

3.2.2 Penetrator Emplacement

Penetrator emplacement describes the loading and penetration of the penetrator once it impacts with the surface. The depth of penetration, the velocities, and the accelerations experienced by the penetrator during impact are given here.

Equations for the depth of penetration take into account soil characteristics, penetrator nose shape, mass to cross-sectional area ratio, impact velocity, and the varying mass and shape of the penetrator sections. This analysis assumes that the soil cross-section is homogenous.

To account for unknown conditions at Mars, both hard and soft soil penetration models were created. The primary concern for a hard soil model is obtaining sufficient penetration without excessive loads. For the soft soil model, the primary concern is limiting the penetration of the aft section of the penetrator. Excessive aft body penetration would prohibit the antenna and afterbody instruments from operating properly. Another soft soil concern involves the design of the umbilical cord connecting the two penetrator sections. If the forebody separated from the afterbody too much, the umbilical cord would break.

The input quantities for the penetration analysis are shown in Table 3.2. Table 3.3 shows the results of the penetration analysis. The results show that the critical accelerations occur in the aft section of the penetrator since its penetration depth is much smaller.

Table 3.2 Penetration Analysis Input Quantities.

Input Variable	Value
Impact Velocity	235 m/s
Nose Performance Coefficient	1.33 / 0.6
Low-mass Scaling Coefficient	0.87068
Hard Soil Coefficient	2
Soft Soil Coefficient	6

Table 3.3 Penetrator Performance.

	Hard Soil Model	Soft Soil Model
Impact velocity	235 m/s	235 m/s
Maximum deceleration	Fore Section: 2,420 g Aft section: 8,455 g	Fore Section: 855 g Aft section: 2,990 g
Total Forebody Penetration	1.54 m	3.66 m
Antenna height (above surface)	0.24 m	-0.3 m

3.2.3 Structural Design

The penetrator must maintain its structural integrity so that the internal instruments and subsystems are not damaged. The penetrator is modeled here as a thin cylinder with titanium as the primary structural material. Steel was also considered as a primary structural material, but titanium saves approximately 5 kg per penetrator in structural mass. The instruments and subsystems are housed in aluminum caging and crushable aluminum honeycomb. The dimensions and relevant information of the penetrator design are given in Table 3.4. A dimensioned schematic of the penetrator design is given in Figure 3.2. The stiffness of the penetrator will be enhanced by the presence of internal structures. This effect will not be considered in this analysis. The following analysis examines the two primary expected failure modes: Euler column buckling and local wall crippling. Future analyses will consider the effect of the internal structures and crushable aluminum honeycomb structure on protecting the internal instruments and subsystems.

Table 3.4 Penetrator Dimensions.

Composition	Titanium nose and walls, with aluminum honeycomb impact attenuators
Nose cone length	20.32 cm
Nose cone, fore section diameter	10.16 cm
Fore section length (incl. cone)	70.21 cm
Fore section wall thickness	0.60 cm
Aft section diameter	20.32 cm
Aft section length (not incl. antenna)	8.47 cm
Aft section wall thickness	0.35 cm
Total enclosed volume	5,577 cm ³
Total structural mass	6.74 kg

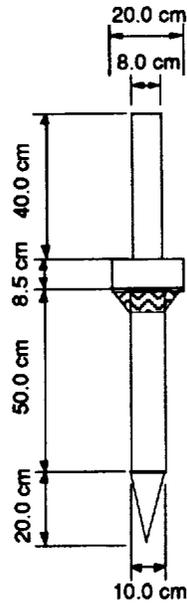

Figure 3.2 Penetrator Dimensions.

For each failure mode, the highest stress experienced within the penetrator wall is used as the basis of the structural design. Only hard soil stresses are considered since soft soil stresses will be lower. The resulting stresses for the hard soil case are shown in Table 3.5. Critical stresses for each failure mode and the corresponding safety factors are given in Table 3.6. These results show that local wall crippling is the limiting failure mode.

Table 3.5 Maximum Stress in Penetrator Walls.

Section	Maximum Stress
Fore	175.7 MPa
Aft	173.1 MPa

Table 3.6 Critical Stresses for Penetrator Loading.

Section	Euler Column Buckling		Local Wall Crippling	
	Critical Stress	Safety Margin	Critical Stress	Safety Margin
Fore	10.87 GPa	60.86	204.3 MPa	16.2 %
Aft	1,646 GPa	9507	205 MPa	18.4 %

3.3 Scientific Instruments

The scientific instruments placed on the surface penetrators will carry out four primary scientific objectives. These four objectives are planetary science, soil analysis, surface imaging, and *in situ* atmospheric measurements. Each penetrator will contain the same scientific payload. The instruments were evaluated based on the following criteria:

- Scientific value
- Weight
- Impact Survivability
- Power requirements
- Cost
- Data requirements
- Operational lifetime
- Compatibility

3.3.1 Planetary Science Instruments

Planetary science is the determination of the interior structure of Mars. This involves the study of the surface structure, global seismology and magnetic field of the planet. Planetary science measurements will be carried out by a seismometer, a decelerometer, and a magnetometer.

Table 3.7 contains a description and the weight, power, and data rate requirements for each instrument. The seismometer is the primary planetary science instrument on the penetrator. The network of three penetrators will provide information on the interior structure of the entire planet. Information on the local surface structure is obtained from the decelerometer which records data as the penetrator impacts the surface. The magnetometer will provide information on the local and global magnetic fields.

Table 3.7 Mass, power, and data rate requirements for the planetary science instrumentation. (7).

Instrument	Function	Mass, kg	Power, W	Data Rate, kb
Seismometer	Seismic activity 3-axes	0.90	0.4	240/day 800/event
Magnetometer	Magnetic field strength 3-axes fluxgate	0.235	0.50	30/day
Decelerometer	Deceleration history Piezoelectric crystal	0.03	0.02	6/event

3.3.2 Soil Analysis Instruments

Soil analysis is the study of the chemical composition, water content, and physical properties of the subsurface soil. The physical properties of the soil include the subsurface temperature and conductivity.

Table 3.8 contains a summary of the soil analysis instrumentation. The α -backscatter spectrometer will be the primary instrument for determining chemical composition. A γ -ray spectrometer could provide complementary data to the α -backscatter spectrometer data, but the γ -ray spectrometer is not compatible with the RTG power source. The radioisotopes emitted by the RTG would contaminate the data taken by a γ -ray spectrometer (8). The water detector uses a P_2O_5 electrolytic cell to measure the presence of water vapor in a soil sample. The thermoprobe is a set of thermocouples located on the umbilical cord of the penetrator which can measure subsurface temperatures. The permittivity meter will provide information about the electrical properties of the ground. The information from the thermocouple array and permittivity meter will enhance the soil composition data obtained from the spectrometers and water detector.

3.3.3 Imaging Systems

Imaging systems on the penetrators will provide information on the geology of the Martian surface. Two imaging systems will be on each penetrator: a descent imager located on the nose of the penetrator and a panoramic imaging system located in the top of the afterbody. The descent imager is a monochrome

camera, which is based on a frame-transfer CCD, and is not designed to survive the impact with the Martian surface. The descent imager has a wide angle lens with a field-of-view of 40° (8). The panoramic imaging system consists of a television camera with black & white and color capabilities. Table 3.9 summarizes the design parameters of the descent and panoramic imaging systems.

Table 3.8 Mass, power, and data rate requirements for the soil analysis Instrumentation (7).

Instrument	Function	Mass, kg	Power, W	Data Rate, kb
α -Backscatter Spectrometer	Subsurface composition Detects C,N,O	0.6	1	16/meas.
Water detector	H ₂ O content P ₂ O ₅ electrolytic cell	0.3	5	3/meas.
Thermoprobe	Subsurface temperature thermocouple array	0.3	1	.05/sec
Permittivity meter	Ground conductivity	0.6	0.5	.5/meas.

Table 3.9 Mass, power, and data rate requirements for the penetrator imaging systems (8).

Instrument	Function	Mass, kg	Power, W	Data Rate, kb
Descent Imager	Surface geology	0.3	2	Real time mem=256 kb
Imaging System	Surface geology Facsimile camera	0.6 \ 0.15	2	512/day

3.3.4 Atmospheric Measurements

A meteorology package containing four distinct instruments will measure the temperature, pressure, humidity, and wind speed and direction of the local atmosphere. The meteorology package must be located near the end of the afterbody of the penetrator. The sensors should be deployed above the penetrator to reduce the effect of the heat flux generated by the other subsystems and to insure that the meteorology package is sufficiently elevated above the surface of Mars. Further investigation of possible deployment methods is necessary. Table 3.10 contains the design parameters for the meteorology package.

Table 3.10 Mass, power, and data rate requirements for the meteorology package instrumentation (8).

Meteorology Package	Function	Mass, kg	Power, W	Data Rate, kb
Thermocouples	Temperature Thin-wire sensor	0.15	.0175	5-10/day
Humicap	Humidity Capacitive sensor	.002	.0019	
Anemometer	Wind speed & direction ion-discharge sensor	.075	.0003	
Barocap	Pressure capacitive sensor	.002	.0019	

3.3.5 Instrumentation Layout

The scientific instruments must be arranged with the penetrator subsystems according to the objectives and requirements of each instrument. The seismometers, for example, must be placed in the forebody of the penetrator structure to eliminate the errors induced by the wind on the surface of the planet. Figure 3.3 is a schematic of the instrument layout within each penetrator.

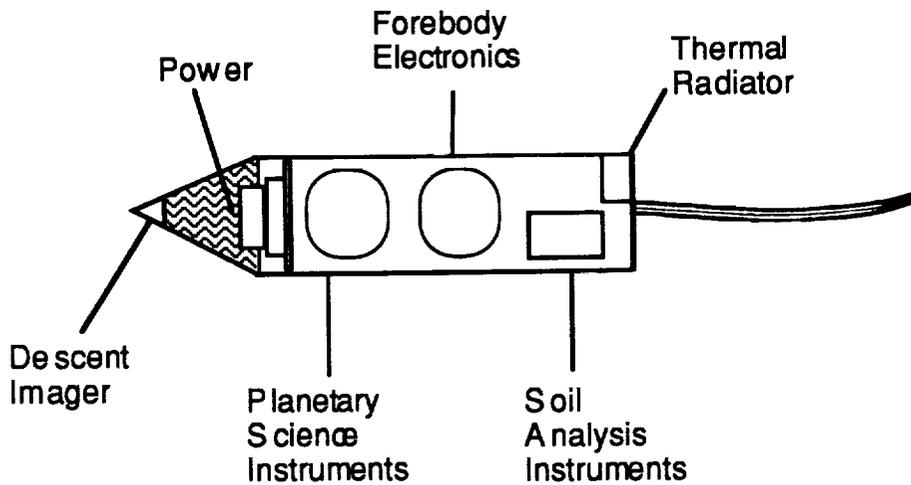

Penetrator Forebody

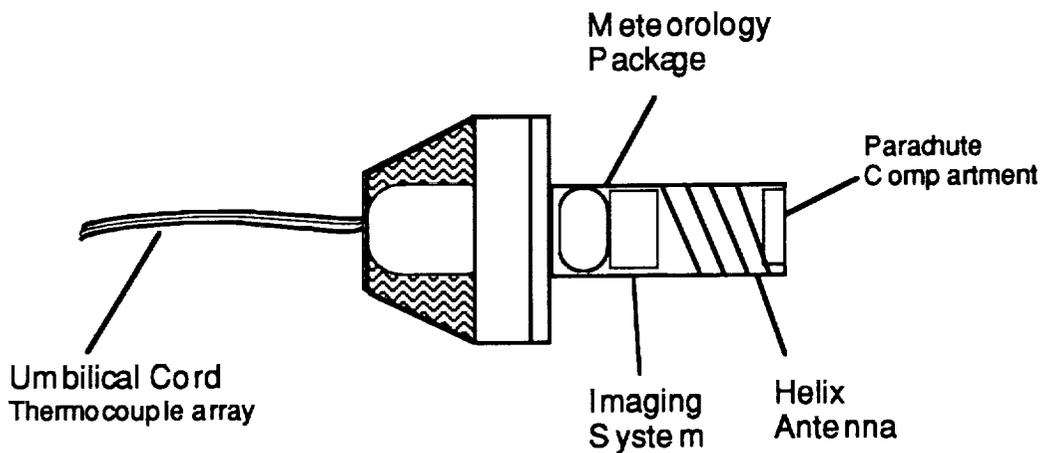

Penetrator Afterbody

Figure 3.3 Schematic of Penetrator Scientific Instrument and Subsystems Layout.

3.4 Penetrator Subsystems

Each penetrator subsystem was chosen on the basis of performance, weight, cost, power requirements, and impact survivability. Each subsystem is detailed in the following section. The mass, power, and volume requirements are

based on the analysis done by Mark E. Johnson in his thesis titled Mars Balloon and Surface Penetrator Study.

For the long-term life of the Mars penetrator, the only two viable choices for the power subsystem are solar arrays and radioisotope thermoelectric generators (RTG's). However, solar arrays have the serious liabilities of poor impact survivability and difficulty in continuous service on the active and harsh environment of the Martian surface. Even though RTG's are expensive and complicated, they have been tested to several thousand g's of loading. Nickel-hydrogen batteries will be used to supply short-term power requirements such as communication with Percival. A 0.5 W RTG with a 20 W battery requires about 2.5 kg of mass and 1000 cm³ of volume.

Communications between the penetrator and Percival is essential. A helix antenna was chosen because a traditional dish antenna could not survive the impact of landing on the surface of Mars. A helix antenna requires about 1.5 kg of mass and a continuous 0.2 W of power for the receiver and a short-term power of 5 W for transmission. A helix antenna of this sort is expected to survive as much as 10,000 g's.

Thermal control is another concern for the harsh environment of the Martian surface. Temperatures on the surface vary from 130 K to 300 K. The batteries need to always operate in the upper range of this band, so they must be heated. Fortunately, RTG's produce waste heat which can warm the batteries. A thermal blanket to surround the batteries and RTG will weigh about 0.3 kg. However, the excess waste heat from the RTG must be transferred away from the penetrator by heat pipes. The heat pipes connect the RTG to the aft section of the forebody. The heat is conducted out of the penetrator and into the soil on the side opposite that of the soil composition instruments to minimize heat contamination of the soil.

The computer and data storage requirements for each penetrator must also be considered. A typical space-certified computer system to meet our requirements has a mass of about 0.25 kg, a power requirement of 0.05 W, a volume of 200 cm³, and can survive about 10,000 g's.

3.5 Low-Cost Alternative

Because of the complexity of the penetrators (such as the use of RTG's and impact hardened components), concerns have been raised about the total cost of each penetrator. If it becomes necessary to lower the cost of the penetrator, a new simpler design must be pursued. First, the RTG's would be replaced with batteries. This would lower the lifetime of the penetrators drastically, lessening the usefulness of instruments such as seismometers, which could then be eliminated. It is also possible that the penetrator structural design can be made into one piece, because the seismometer requirements will not have to be considered if they are eliminated. All of the above changes will significantly lower the cost of the penetrators.

3.6 Summary

In summary, the surface penetrators are composed to two primary sections; the forebody, which penetrates into the surface, and the afterbody, which remains on the surface. A small solid rocket deorbit motor provides for deceleration from orbit, and a 1.14 m diameter drag chute slows the penetrator down to acceptable velocities. An umbilical cord containing power and communication lines connects the two sections. Each penetrator contains instruments for planetary science, soil composition, imaging, and meteorology. An RTG provides power for the penetrator, with a nickel-hydrogen battery providing for short-term power needs.

Table 3.11 contains the mass and power summary for each penetrator. The penetrators were allotted 75 kg of total mass, so three penetrators can be carried by Percival. The total power of the instruments and subsystems is also less than the maximum power provided by the RTG's.

Table 3.11 Penetrator Mass and Power Summary.

System	Mass (kg)	Power Req. (W)
Forebody and Nose Cone	4.93	0
Afterbody and Terrabrake	1.84	0
Internal Caging	0.75	0
Drag Chute	3.5	0
Deorbit Motor	5	0
Planetary Science Inst.	1.17	0.16
Soil Composition Inst.	1.2	5 Peak
Imaging Systems	0.9	2 Peak
Meteorology Instruments	0.23	0.025
Helix Antenna	1.38	5 Peak / 0.2
Computer and Data Storage	0.25	0.043
Power System	2.32	0.048
Thermal System	0.5	0
Umbilical Cable	0.5	0
Totals	24.47	0.476

4.0 Gravity Field Mapping and Science Instruments

As a precursor to future manned and unmanned missions, Percival is responsible for collecting a multitude of data about Mars. Instruments onboard Percival will provide detailed information about the Martian gravity field and the surface composition of Mars, adding to the data that will be compiled by the Mars Observer spacecraft. Mars Observer will be measuring the Martian gravity field using radioscience techniques. The Percival mission plans to improve and augment on the gravity field mapping carried out by Mars Observer. The surface composition instrument has been placed aboard Percival since this instrument was not within the Mars Observer budget. By adding to and improving the data that Mars Observer is collecting, a better understanding of Mars will be achieved.

4.1 Gravity Determination Techniques

One of the primary mission objectives of the Percival mission to Mars is to improve and augment the gravity map determined by Mars Observer. In order to accomplish this goal, Ares Industries considered three gravity measuring techniques. These three techniques are listed below:

- Gradiometers
- Doppler tracking
 - Spacecraft to spacecraft
 - Earth to spacecraft
- RADAR tracking

4.1.1 Gravity Gradiometry

Gradiometers map the gravity field by measuring changes in accelerations using sensitive accelerometers. Figure 4.1 is a schematic design of a single accelerometer.

Changes in acceleration are measured as changes in capacitance along the radial and transverse directions. Measuring the gravity field with gradiometers is a simple concept and one that has been tested on the ground and in aircraft, however, it has never been proven in space nor has the proposed accuracy of 10^{-2} to 10^{-4} Eotvos been achieved. There are professionals working on space based gradiometers such as Dr. Paik at the University of Maryland,

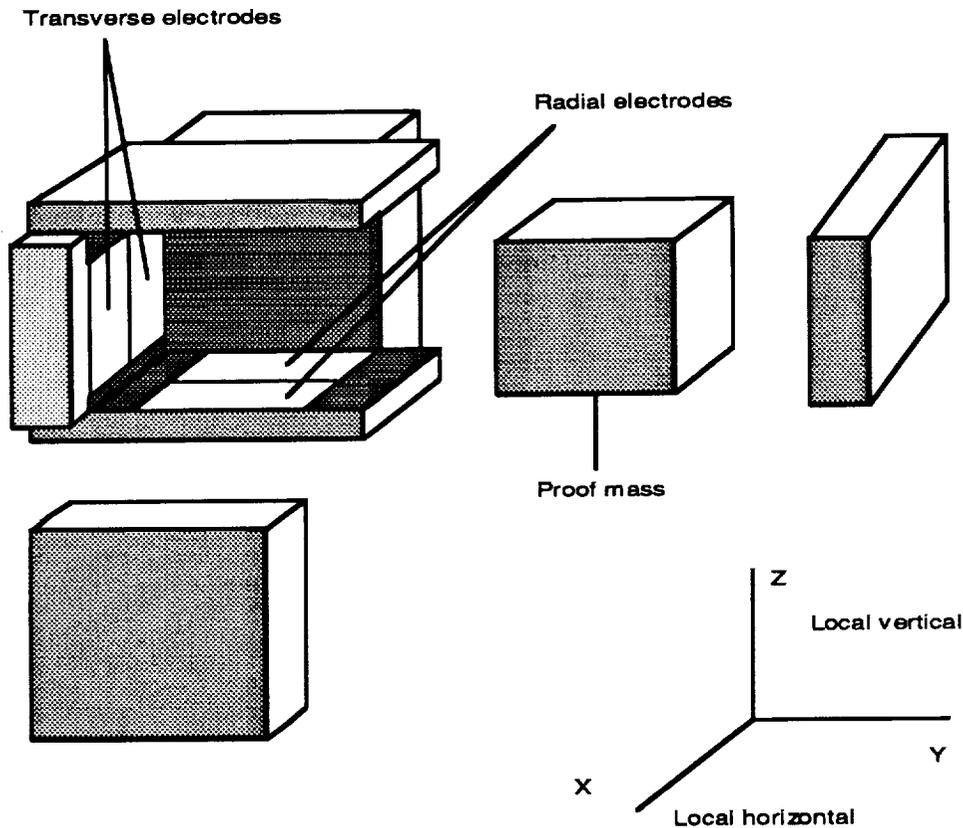

Figure 4.1 Dual Axis Accelerometer Preliminary Design (9).

who believe that it is possible to put gradiometers in space with available technology (10). Such a system would not achieve our proposed accuracy but it may be able to achieve an acceptable accuracy of 1 to 10^{-1} Eotvos, which would still be an improvement over the Mars Observer measurements. The difficulty with this system is that any slight acceleration not caused by the gravity field around Mars will pollute the data. These accelerations could be caused by a number of things such as fuel sloshing, thermal variations, antenna movements, and attitude adjustments. However, if the acceleration is known and is not too large, it can be accounted for in the data reduction. The challenge is thus designing a guidance and control system capable of providing and maintaining a highly accurate attitude.

4.1.2 Radioscience Gravity Mapping (Doppler shift measurements)

Doppler tracking measures the gravity field of a planet indirectly by tracking the changes of a spacecraft in orbit. More specifically, this method measures the change in frequency of the tracking signal. These determinations

can be performed from one spacecraft to another or from Earth to a spacecraft. If the spacecraft to spacecraft approach is considered the receiving spacecraft, or target spacecraft, must be capable of receiving and returning a radio signal sent from the measurement spacecraft, causing the operating lifetime of the target spacecraft becomes a constraint on mission design. Further, the target spacecraft must be in view of the measurement spacecraft. In this approach, too much of the gravity field measurement is dependent on the target spacecraft. The Earth to spacecraft approach on the other hand is a well proven technique which does not rely on a second spacecraft. Percival does however have to compete with Magellan, Galileo, Mars Observer and other planetary explorers for Deep Space Network (DSN) time. Doppler tracking is a low cost, well proven method and is currently being used by Mars Observer to map the gravity field around Mars (10).

4.1.3 RADAR Tracking Gravity Mapping

RADAR tracking is similar to Doppler tracking measurements, but the signal from one spacecraft to another or from Earth to a spacecraft is measured after it rebounds off the target. RADAR tracking requires more power than Doppler because it must send out a signal strong enough that its reflection can be sensed. The RADAR tracker must also be capable of accurately tracking its target. For the above reasons, RADAR tracking was eliminated as a feasible method of gravity field determination.

4.2 Spacecraft Interface

The choice to use gradiometers to map the gravity of field of Mars affects the rest of the spacecraft. There are three main areas affected which will each be discussed in the following sections. They are:

- Attitude determination
- Spacecraft orientation
- Subsystem interface

4.2.1 Attitude Determination

Gradiometers are more sensitive than Doppler or RADAR measurements, and therefore require more precise knowledge of the attitude of the spacecraft.

The precision with which Percival will need to be able to determine its attitude are listed in Table 4.1 (12).

Table 4.1 Gradiometer Attitude Control Constraints.

Pitch, yaw, and roll	< 0.05°
Angular rate	< 0.10 ⁶ rad/sec
Angular Acceleration	< 10 ⁻⁸ rad/sec ²
Linear Acceleration	< 10 ⁻⁸ m/sec ²

The instruments used to determine the attitude of the spacecraft must not create vibrations which would affect the gradiometer readings. The following instruments will be used to determine the attitude of Percival.

- Fixed head star tracker
- Sun sensor
- Ring laser gyroscopes

4.2.2 Spacecraft Orientation

In order to measure the gravity field of a planet, gradiometers sense changes in acceleration. As a consequence, anything that produces an acceleration will affect the gravity field measurement. Most planetary spacecraft orbit in a local vertical - local horizon reference frame. In this reference frame, one axis in the spacecraft is always pointed perpendicular to the local horizon and usually the spacecraft is spin stabilized. This orientation has the advantage that the scientific instruments are always pointing toward the planet that they are observing. However, in this reference frame, the (ω^2r) centrifugal acceleration will affect the gradiometer readings. For an accurate measurement, the ω^2r must be known precisely so that it may be taken out of the data or the gradiometer must be a single axis gradiometer. When using a single axis gradiometer, two accelerometers (one for redundancy) are placed on the spin axis of the spacecraft so that there is no ω^2r term to determine (6). This limits the spacecraft to measuring changes in gravity in only the local vertical direction but this is still an improvement on Mars Observer's data.

The inertial reference frame orientation, in which one axis of the spacecraft is always pointed toward a distant object and the spacecraft does not

rotate as illustrated in Figure 4.2, eliminates the centrifugal acceleration term. However, now the scientific instruments can not always observe the planet and the direction of the transmitting and receiving communication antennae change position with respect to the Earth. This is not a convenient attitude for the Visible Infrared Mapping Spectrometer (VIMS). In addition, the movement of the antenna will create unwanted accelerations.

- Distant Star

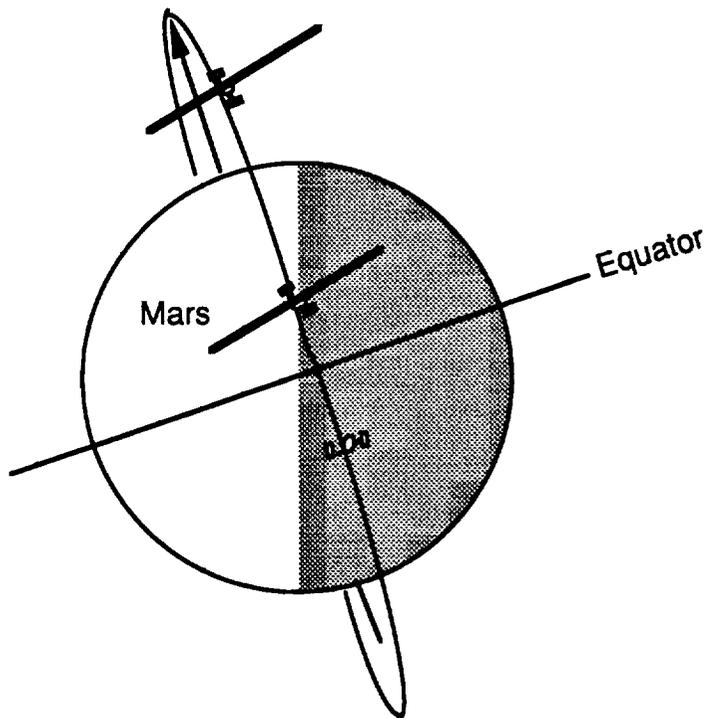

Figure 4.2 Inertial Reference Frame.

4.2.3 Subsystem Implications

The two other subsystems that the gradiometers and attitude control affect are the propulsion and thermal systems. The propulsion system must be designed to prevent fuel sloshing because the resulting vibrations affect the gravity measurements. Multiple fuel tanks would lessen fuel sloshing (13). Also, cryogenic cooling would increase the accuracy of the gravity measurements. In our proposal, Ares Industries initially proposed a level of accuracy of 10^{-2} to 10^{-4} Eotvos. To achieve this level of accuracy, Percival's gradiometers would have to be cryogenically cooled (12). However, cryogenic cooling would add extra mass to the Percival spacecraft. A level of accuracy of 1 to 10^{-1} Eotvos is

possible without cryogenic cooling and is still considerably more accurate than the readings of Mars Observer (10).

4.2.4 Mass, Volume, and Power Requirements

The following table (Table 4.2) summarizes the mass, volume, and power requirements for the gradiometers and the two scientific instruments.

Table 4.2 Mass, Volume, and Power Requirements of Gradiometer and Science instruments.

	Dimensions	Mass	Power
Each Gradiometer	60x60x90 cm	50 kg	65 - 125 W
VIMS	120x64x52 cm	22 kg	74 W
Balloon Relay	dia 5 cm length 60 cm	6.8 kg	12.5 W

note: VIMS - Visible Infrared Mapping Spectrometer

4.3 Scientific Instruments

The two instruments carried on Percival are a Visible and Infrared Mapping Spectrometer (VIMS), shown in Figure 4.3, which was cut from Mars observer due to funding, and a Mars Balloon Relay (MBR) communications system (14). The VIMS instrument uses imaging spectrometry to identify the spectral features of Mars in the visible and infrared regions. The spectral data will provide a mineralogical map of the Martian surface and a concentration map of water and carbon dioxide in the atmosphere (clouds) and on the surface (frost and snow) of Mars (14). The MBR serves as a communications link between surface vehicles and Earth (11). The MBR will operate beyond the science phase of the Percival mission.

The VIMS has two data acquisition modes: mapping mode and snapshot mode. Mapping mode takes a representative sample of the surface. In this mode every other 182 m pixel is read and every other scan line is skipped. The snapshot mode is a much more comprehensive sampling mode. In this mode every pixel is read and every line at full resolution. A maximum area of 53.46 km² may be mapped in this mode. Typically, the mapping mode will be used for most data acquisition while the snapshot mode will be used for detailed maps of

specific areas of interest. VIMS provides a 512 kbyte buffer to accommodate both modes of data acquisition.

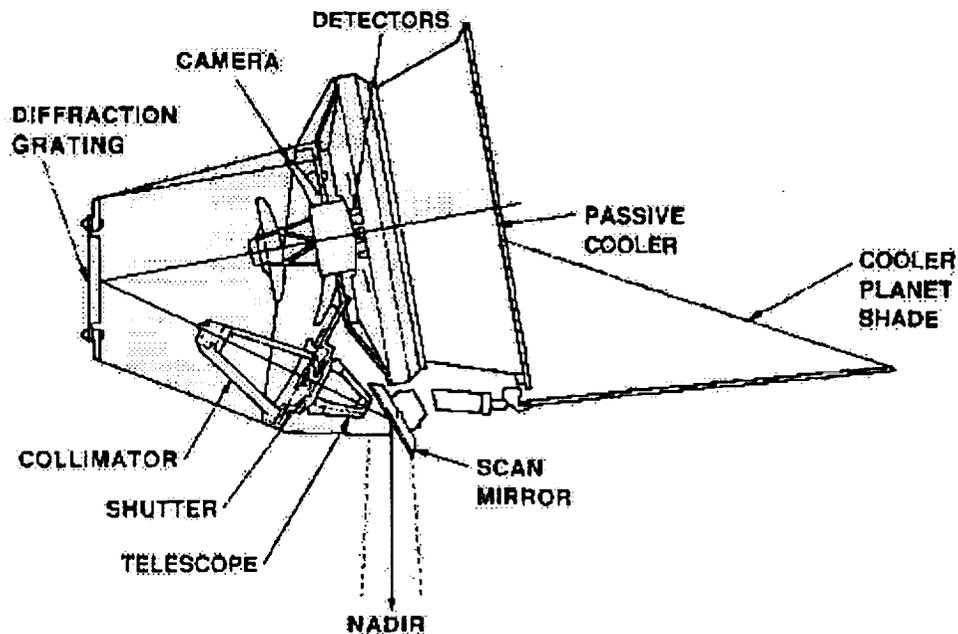

Figure 4.3 Visible and Infrared Mapping Spectrometer Schematic (14).

4.4 Summary

To summarize, the gravity mission objective will be achieved through the use of gravity gradiometers. Following lists the major points of the gradiometers:

- Accelerometers on the axis of rotation
- Reads lower and higher order gravity terms
- Precise attitude and position necessary
- Local vertical - local horizon orientation
- Propulsion system - multiple fuel tanks
- No cryogenic cooling necessary
- Readings from 1 to 10^{-1} Eotvos
- Readings taken for 1 - 2 Martian years
- Doppler shift measurements used as backup
- Doppler shift measurements augment Mars Observer's data if resonance designed accordingly

For the future, costs for these instruments need to be determined, radioscience techniques need to be investigated further, and the design of the gradiometer needs to be refined.

5.0 Spacecraft Structure and Subsystems Design

The purpose of this section is to consider options for the spacecraft structure (bus) and subsystems. Two potential spacecraft busses were being considered prior to the PDR1 phase, one of which included a new design using aerobraking. The second option for the spacecraft bus was a scaled down version of the Planetary Observer class spacecraft. These two alternatives were examined carefully and a decision was made based on mission requirements and costs.

In addition to determination of the spacecraft structure, this section also examines the subsystems that will be used on the Percival spacecraft. The subsystems included are power systems, thermal control, communications, and guidance, navigation, and control (GN&C). Where applicable, there is a brief discussion as to why a particular subsystem was chosen over a competing subsystem.

5.1 Spacecraft Structure

As mentioned previously, one consideration for the spacecraft bus was a new design utilizing aerobraking. This design was ruled out because the thin Martian atmosphere will not be able to supply the necessary drag required for considerable propellant savings. Also, a new design, which would incorporate an aeroshell to protect the spacecraft, would require extensive research and development (R&D). Thus, a scaled down version of the Planetary Observer class spacecraft (currently used on the Mars Observer mission), with slight modifications, will be used (see Figure 5.1). Ares Industries feels that this design will minimize R&D costs and provide valuable feedback on the reliability and performance of the bus (based on information attained from the Mars Observer mission).

5.2 Power Subsystem

The Percival spacecraft will be powered by a Radioisotope Thermoelectric Generator (RTG) and a small battery for peak power requirements. An RTG was chosen as the main power systems because of its excellent mass to power ratio, having a mass of 50 kg and supplying about 300 W of power. Because RTG's

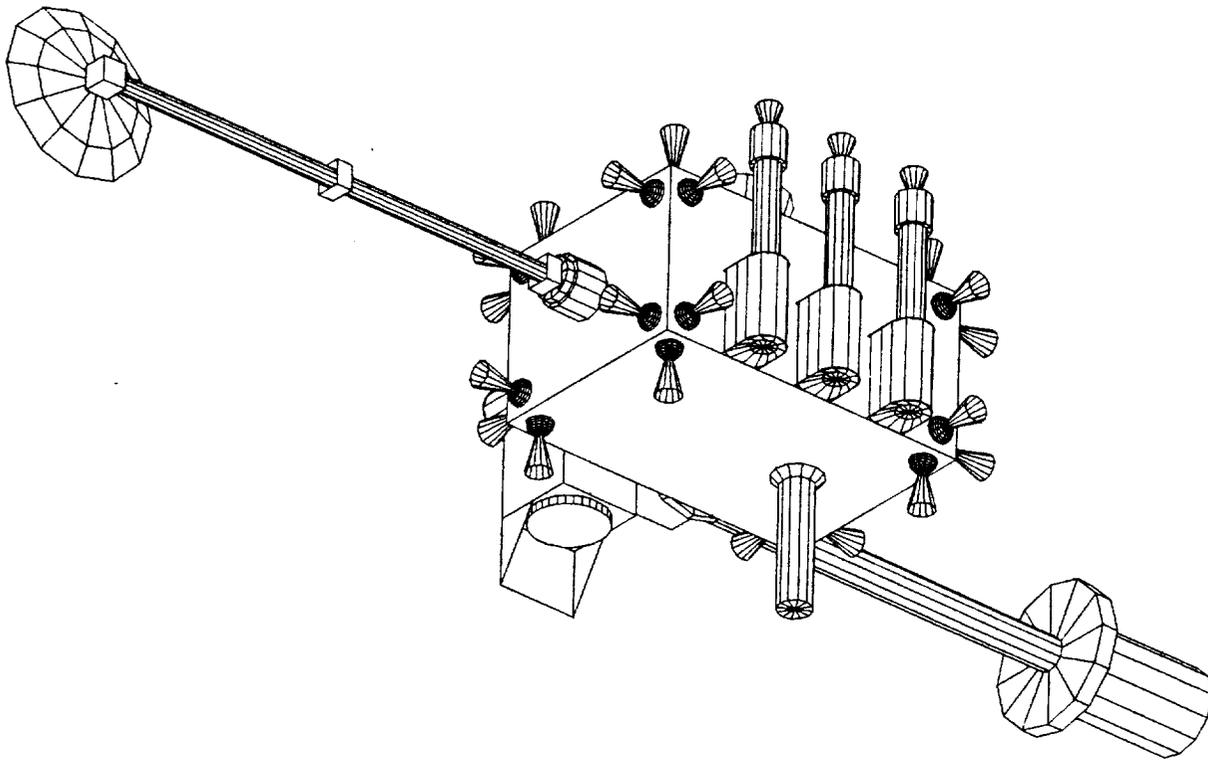

Figure 5.1 Scaled Down Version of Planetary Observer Spacecraft.

use a Plutonium 238 isotope that can only be irradiated at the Savannah River Reactor, it is extremely expensive to manufacture an RTG (estimated at \$20,000 per watt produced by the RTG). Currently, the Savannah River Reactor is not operable and will require several months of start up time in addition to at least 30 months for production of the 238 isotope (15). Because of the present costs and time constraints, other sources of plutonium 238 should be found, such as the stores which were previously reserved for the now canceled CRAF mission. Strontium 90, an isotope that is produced as a byproduct in nuclear power reactors, is also being considered as a potential fuel for the RTG. This material is readily available and also has an excellent mass to power ratio (16). Strontium 90 was used in SNAP devices (early RTG's) but has never been used on RTG's in space (16). It may be expensive to separate Strontium 90 from other reactor products, and the feasibility of using this material in space has not been investigated fully.

At one point in the mission design, consideration was given to the use of solar arrays as a potential power source. They were discarded as an option because of the creation of mechanical noise that would occur during realignment phases. The gradiometer that will be used for gravity mapping is highly sensitive to mechanical noise. Therefore, unnecessary mechanical noise could bias scientific data. Also, because the solar arrays occupy a considerable area around the spacecraft, they could infringe upon the reception and transmission of telemetry data.

5.3 Thermal Control Subsystems

Both active and passive thermal control measures will be used by the Percival spacecraft. Passive thermal control devices include thermal blankets and surface coatings (15). Ares Industries felt that the active thermal control devices should be limited to those that create the least mechanical noise while still meeting the requirements of both subsystems and science instruments. Therefore, freon radiators will be used by Percival for cooling where required. Heaters will supply any necessary temperature increases on the spacecraft.

5.4 Communications Subsystem

The Percival spacecraft has two independent communications systems. First, the Mars Balloon Relay (MBR) instrument will relay data between the penetrators or future surface missions and Percival. This instrument comprises an antenna, transmitter, and receiver in one package. The penetrator data is relayed between 401 and 406 MHz. The MBR antenna has no pointing capabilities and is fixed to the "Mars-facing" side of the spacecraft. The spacecraft will be in view of the penetrators for a maximum of 215 seconds on each pass, and during this time, the MBR and the penetrator will establish communications and relay the penetrator's accumulated data. The data transfer rate for the MBR is limited to 16 kbps (thousand bits per second); therefore 200 kilobytes of data can be transferred in a typical 100 second pass.

A parabolic high-gain antenna will provide communications with Earth. An antenna size of 1 m will provide acceptable performance. The system will operate in the X band at 8.4 GHz, which is a standard frequency for space communications. Calculations of the total system performance show that for a

transmitter output power of 5 watts RF and a data rate of 150 kbps, for the worst case scenario when Earth and Mars are 2.5 AU apart, the received signal to noise ratio will be 9 dB for the 34-m and 15 dB for the 70-m Deep Space Network (DSN) antennas (16, 17). This signal to noise ratio is sufficient to ensure reliable communications with Earth. The transmitter will use solid-state electronics and will require 20 watts of electrical power when operating. The half-power beamwidth of the 1-meter antenna, at this frequency, is 2.5° . In the worst case, when Earth is at its maximum elongation as seen from Mars, this beamwidth will require that the antenna be repointed every two minutes. Due to the accelerations and rotations caused by antenna movement, no gravity gradiometer data can be taken during the repositioning. A low-gain antenna will also be included on Percival for contingency communications if the high-gain antenna cannot be used or loses Earth point. The low-gain antenna will be helical with a beamwidth of 67° , which is sufficient to maintain communications without the need to repoint the antenna. The maximum data rate if the low-gain antenna must be used is 1200 bps.

The mapping orbit has a period of 108 minutes, with 52 minutes available for data playback to the DSN antennas on Earth. It is anticipated that the Percival mission will receive a DSN allocation equal to that of Mars Observer, which uses one 8-hour period per day on the 34-meter HEF subnet antennas to transmit to Earth. In one 8-hour DSN pass, Percival can transmit data over four orbits, for a total of 1622 megabits of data transmitted to Earth per day.

The data sent to Earth will be encoded by the Reed-Solomon method, which encodes redundant bits with data bits in such a way that if errors are introduced during transmission, the original data can be recovered if the errors are not too serious. The Reed-Solomon code replaces every 218 bits of data with 250 bits of encoded data, resulting in a communications throughput speed of 130 kbps.

5.5 Guidance, Navigation, and Control

A precise and reliable guidance, navigation, and control system is essential to the successful completion of Percival's mission objectives. Each subsystem is designed to meet the requirements imposed by the overall spacecraft and scientific objects. The guidance system determines where the spacecraft needs to go, the navigation system determines where the spacecraft

is, and the control system performs the acts necessary to get the spacecraft from where it is to where it needs to go. The guidance, navigation, and control subsystems are described in the following paragraphs.

5.5.1 Guidance

The guidance system for Percival is contained on the spacecraft. Percival will utilize autonomous guidance with ground based override capability. Spacecraft-based guidance does impose slightly more weight, power, and cost penalties on Percival than does ground-based guidance. However, for reasons of practicality and mission safety, ground-based override capability will be used.

5.5.2 Navigation

Percival will have a variety of navigation instruments, such as sun sensors, a star sensor, and a ring-laser gyroscope. The sun sensor is used as a coarse acquisition sensor. In other words, it is used to estimate the attitude of the spacecraft, to an accuracy between 0.01 and 0.1 degrees, so that the star sensor can then be used to improve the accuracy of the attitude determination. Percival will have four sun sensors, which will allow the spacecraft attitude to be determined from any initially unknown position. Percival will also have a fixed-head star tracker, which will provide a very accurate position measurement for Percival on the order of 0.001 degrees of accuracy. The fixed-head tracker will be used in lieu of a gimbaled star tracker in order to minimize mechanical noise, weight, and cost. Finally, Percival will contain a ring-laser gyroscope. Ring-laser gyroscopes use certain properties of light to determine attitude rates. The ring-laser gyroscope has many advantages over conventional gyroscopes, including greater accuracy and reliability and lower weight. The gyroscope will keep track of the attitude in between star tracker measurements, and the star tracker will update the gyroscope in order to minimize drift error. Ring-laser gyroscopes are a new technology, but they have been proven on the Boeing 757 and 767 as well as the Orbital Sciences Transfer Orbit Stage. This combination of instruments will satisfy all of the navigation requirements for Percival (15).

5.5.3 Control

Twenty-four reaction control jets will be used for attitude control on Percival. Two separate attitude control systems will be used for reliability purposes, with each system containing its own independent fuel system. Three-

axis control capability will be available because of the distribution of the twelve jets in each control system. The distribution also allows the control system to survive a single jet failure without impairing the ability of the control system. Figure 5.2 shows a schematic representation of the control system. One of the control systems will contain hydrogen, or cold-gas, thrusters for fine attitude control. The other control system will be composed of hydrazine, or hot-gas, thrusters with a catalyst for higher thrust and lower accuracy requirements. Two control systems were considered essential to meet mission requirements in the event of a single system failure.

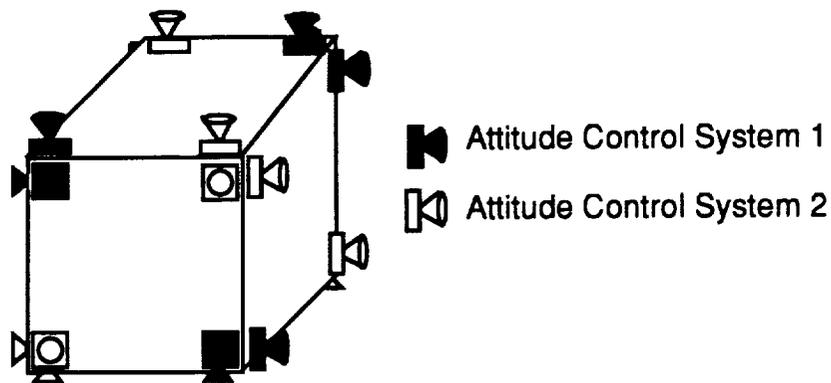

Figure 5.2 Dual Attitude Control System for Percival Spacecraft.

5.6 Summary

In summary, the Percival spacecraft will utilize a scaled down Planetary Observer with power supplied by an RTG and battery. Thermal control devices include thermal blankets, surface coatings, heaters, and freon radiators. Percival will use the Mars Balloon Relay System for reception of penetrator data and a high gain antenna for penetrator and science instrument data transmission to earth in real time. The onboard computer system will also have the ability to store data for periods when Percival is not in its transmission zone. A low-gain antenna will be used for backup and redundancy purposes. The spacecraft will have completely autonomous guidance with ground based override capability. Sun sensors, a star sensor, and a star tracker will be used for attitude determination, while ring laser-gyroscopes will be used for rotation rate determination. Percival will contain 24 hot and cold gas reaction control jets capable of both low and high precision attitude control maneuvers.

Finally, Table 5.1 contains the mass and power requirements of the spacecraft structure and systems. The total mass, 1262 kg, shown in Table 5.1 is inclusive of a 10% safety factor. However, this spacecraft mass is 75 kg over the mass budget for Percival. The power requirement of 299 W (this is a peak value) does fall within the 300 W that can be produced by the RTG.

Table 5.1 Mass and Power Requirements for Percival.

System	Mass (kg)	Power Reqr. (W)
Penetrators	75	0
MBRS	6.8	12.5
VIMS	21.7	11.4/51.4
Gradiometer	49.5	125
GN&C	85	55
Communications	12	28
Computer System	7	5
RTG	50	0
Batteries	5	8
Propulsion	790	0
Thermal Control	30	14
Spacecraft Structure	130	0
Totals	1262	299

6.0 Management Structure and Cost Summary

6.1 Management Structure

The organizational structure of the Percival mission design team is shown in Figure 6.1. The project was managed by three upper management personnel: the Team Leader, the Chief Engineer, and the Chief Administrator. The design work was divided among four technical areas: Orbital and Propulsion System Design, Surface Penetrator Design, Gravity Field Mapping and Science Instrumentation, and Spacecraft Structure and Subsystems Design. Each technical element was composed of three engineers and was headed by an element leader. This organizational structure remained essentially the same since the project start. Workload demands in the elements necessitated shifting of engineering personnel between elements to accommodate increased or reduced workloads.

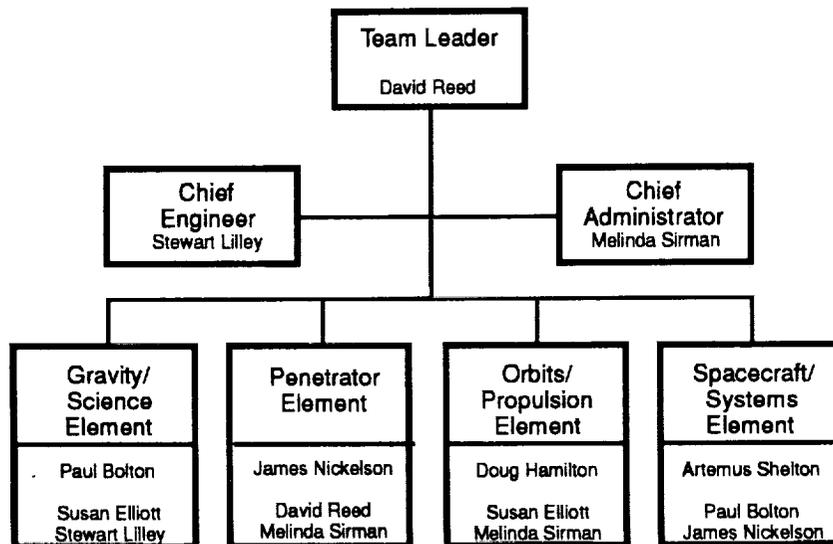

Figure 6.1 Percival Design Team Organizational Structure

Integration efforts were conducted by the element leaders, headed by the Chief Engineer. The task of building a spacecraft model was headed by the Spacecraft Systems element lead. Personnel for this task were taken from all elements. The task of creating a poster describing the mission was given to the upper management personnel.

The client for the Percival project asked that the Ares Industries management use and evaluate MicrosoftProject® software designed to help create scheduling and critical path charts. Initial work was done to create Gantt and PERT charts for the Percival project using MicrosoftProject®. Recommendations for use of this software product will be made to the contract monitor.

6.2 Cost Summary

The cost for the preliminary design portion of the project has been broken into personnel cost and material cost. A preliminary cost for the Percival Mission to Mars launch and space segments was also calculated using parametric cost estimating relationships (19). The following sections discuss each of these cost areas.

6.2.1 Personnel Cost

Personnel cost have been tracked using weekly progress reports from each design team member. The personnel cost for the design effort up to the end of week 13 is shown in Figure 6.2. The total personnel cost is currently \$24,786. This is approximately \$4,500 below the proposed cost expected at this date. The discrepancy is due to an overestimate of the number of hours worked weekly by the engineering personnel. Appendix C contains a detailed breakdown of the personnel cost by team member.

6.2.2 Material Cost

The material costs used in the design effort came in on schedule with the proposed material costs.

6.2.3 Preliminary Cost Estimate

The total cost of the Percival Mission to Mars is estimated to be \$271 million (fiscal year 1990 constant dollars). Appendix C contains a summary of the cost for each portion of the space segment of the mission (32). The total cost is over the proposed "discovery class" mission philosophy cost of \$150 million. Ares Industries has concluded that the primary scientific goals of the Percival mission (improved gravity mapping and penetrators) cannot be accomplished within the current discovery class definition. The gravity gradiometer and

penetrators are new technologies that are costly additions to the Percival Mission to Mars.

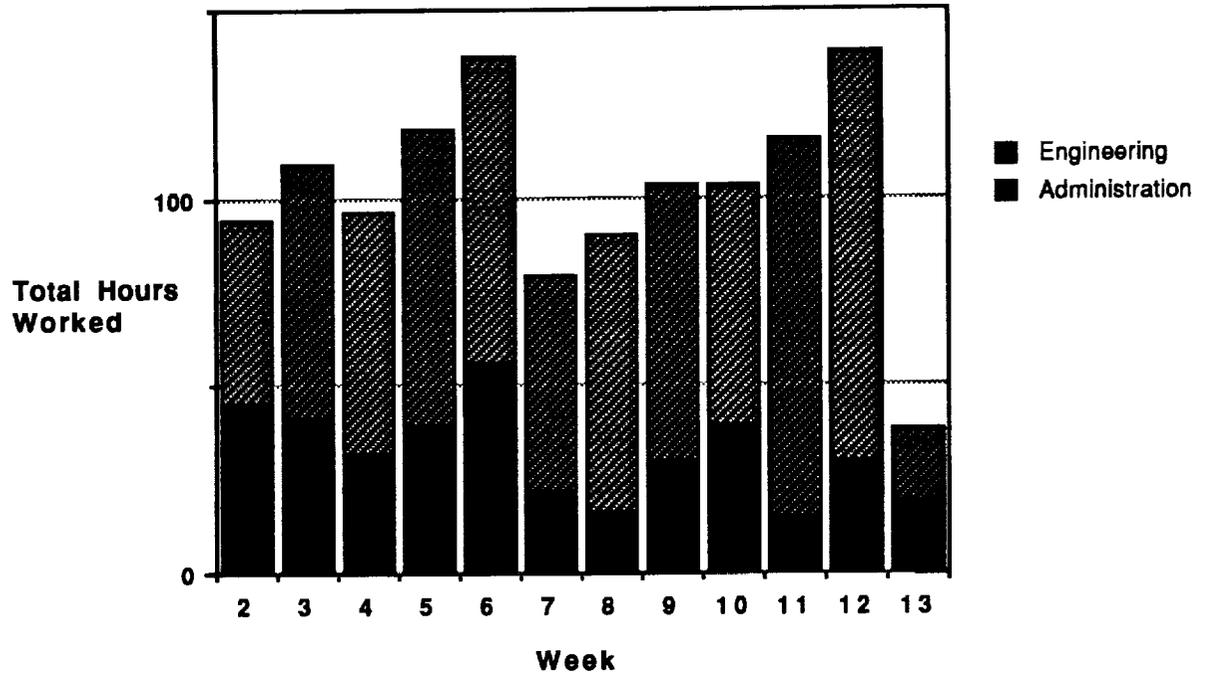

Figure 6.2 Personnel Cost Status

7.0 Conclusions

The main objectives of the Percival mission are to make gravity field measurements at Mars that will augment and improve the Mars Observer gravity mapping, to deploy penetrators to Mars as a precursor to future missions, and to provide a platform for scientific instrumentation that was originally planned for Mars Observer. These objectives were to be designed into the mission with a low-cost "Discovery-class" design philosophy as the driver.

Each of the three scientific payloads on Percival was designed to meet the desired objectives. The gravity gradiometer will provide more accurate data than Mars Observer's gravity map will contain. The Doppler-shift measurement capability, used as a backup to the gradiometer, will still augment the Mars Observer gravity map, though the accuracy of the map will not be improved. Three individual penetrators will be deployed to separate regions of Mars to collect surface and sub-surface data. This data will help future mission designers to choose the most feasible and most scientifically interesting landing sites on Mars. The VIMS will be carried aboard Percival, fulfilling the scientific platform objective.

The "Discovery-class" design philosophy specifies a low-cost, limited mission, and available technology design. This design philosophy was violated in several areas. Though Percival has fewer primary scientific packages than previous spacecraft, such as the seven instruments on Mars Observer, three primary scientific objectives may still be too high for a "Discovery-class" mission.

Spaceborne gradiometers can not be considered as available technology. Gradiometers have been used in aircraft and on ships, but never in space. Much disagreement about the obtainable accuracy of gradiometers exists. Ares Industries has claimed only a moderate accuracy of 1 Eotvos is possible with spaceborne gradiometers. Since this technology is untested, Doppler-shift measurement capabilities will be designed into Percival with negligible additional weight or cost.

The most prominent violation of the "Discovery-class" design philosophy was the low-cost specification. The estimated design, development, and production costs for the Percival mission is \$270 million, compared to the "Discovery-class" goal of \$150 million. The scientific instruments and the RTG's are major contributors to the cost estimate. The nature of the gradiometer and the VIMS as single-use instruments makes them more expensive than other

spacecraft instruments. Impact-hardened instruments on the penetrators will cost considerably more than their standard counterparts. Also, the extremely limited availability of RTG's makes them very expensive.

Though each of the scientific payloads was integrated into the Percival spacecraft design, the total spacecraft mass is greater than the specified launch system can support. The Delta 7925 with an additional upper stage allows for a spacecraft dry mass of 460 kg at Mars. The current integrated spacecraft which meets all of the mission objectives has an estimated mass of 535 kg. Ares Industries has concluded that the primary scientific goals of the Percival mission cannot be accomplished within the current "Discovery-class" definition and cannot be accomplished with a Delta-class launch vehicle.

8.0 Recommendations

With the constraint of the Delta-class launch vehicle, Ares Industries was not able to design the Percival mission to include all of the mission objectives within the allowable weight. The spacecraft as designed is 75 kg over the mass budget, which is the exact weight of the penetrator system. Although undesirable, it would be possible to use the Delta vehicle to launch the Percival mission without the penetrator system. At this time, the only alternative available to launch the full Percival mission would be to choose a larger, more expensive launch vehicle.

Technology must be developed further for the full Percival mission to be launched using a Delta-class launch system. One modification that has been examined is the modification of the GEM motors. The performance of the GEMs would be increased by lengthening the motors. Other future alternatives might be the use of upper stage motors with better performance characteristics than the Star 48B's currently used.

Ares Industries has concluded that the current mission objectives cannot be accomplished within the current definition of the "Discovery-class" design philosophy. If the "Discovery-class" mission becomes a necessary constraint, one of the three primary scientific packages should be chosen as the single, primary mission of the Percival spacecraft. This choice will reduce both the complexity and the cost of the mission.

To design the Percival Mission to Mars beyond the preliminary design phase, detailed design must be done for all portions of the project. The following issues must also be considered. For the propulsion system, the type of propellant must be chosen to give a more precise estimate of the fuel mass required. The penetrator system requires the accuracy of the penetrator targeting to be determined in addition to the effects of winds on the entry trajectory and attitude of the penetrator. Also, the susceptibility of the penetrator structure to failure during an oblique impact must also be considered. The feasibility of increasing the data rate of the Mars Balloon Relay should be determined. For the spacecraft power system, the feasibility of using a Strontium 90 RTG should be further analyzed. The GN&C system of Percival should be analyzed in more detail to determine if it satisfies the position and rate determination and control requirements defined by the gradiometer.

9.0 References

1. Robinson, Dr. Paul, Assistant Chief Technologist for JPL, Phone interview on 10/06/92.
2. -----, "Delta", Delta Systems Program Office, Los Angeles, California, 1990.
3. -----, "Star Motor Data", in ASE 166M Class Notes, University of Texas at Austin, 1986.
4. Bate, Roger R., Donald D. Mueller, and Jerry E. White, *Fundamentals of Astrodynamics*, Dover Publications, Inc.: New York, 1971.
5. Beerer, Joseph G. and Ralph B. Roncoli, "Mars Observer Trajectory and Orbit Design", *Journal of Spacecraft and Rockets*, Sept-Oct 1991, American Institute of Aeronautics and Astronautics, Washington, D.C.
6. Fowler, Dr. Wallace, Professor Department of Aerospace Engineering and Engineering Mechanics, University of Texas at Austin, Personal Interview.
7. Johnson, Mark E. "Mars Balloon and Surface Penetrator Design Study," Master's Thesis, University of Texas at Austin College of Engineering, May 1990.
8. Chicarro, A.F., et al, "MARSNET Report on the Assessment Study", ESA Publication SCI(91), 6 January 1991.
9. Bettadpur, Srinivas, Department of Aerospace Engineering and Engineering Mechanics (Graduate student), University of Texas at Austin, Personal Interview.
10. Lundberg, Professor Department of Aerospace Engineering and Engineering Mechanics, University of Texas at Austin, Personal Interview.
11. McKinley, E.L., "Mars Observer Project: An Introduction", *AIAA Journal of Spacecraft and Rockets*, vol. 28, No. 5, 489-490, Sept.-Oct. 1991.
12. Sanso, F. and Rummel, R. *Theory of Satellite Geodesy and Gravity Field Determination* - Notes compiled from a symposium, New York, 1988.
13. Griffin and French, "Space Vehicle Design", AIAA, Inc., 1991.
14. Blume, Bill, Mission Planner for Mars Observer, Jet Propulsion Laboratory, Pasadena, CA, Phone interview.
15. -----, *Spacecraft Subsystems (Student Spacecraft Subsystems Descriptions)*, Department of Aerospace Engineering and Engineering Mechanics, University of Texas at Austin, January 1992.
16. *CRC Handbook of Physics and Chemistry, 49th Edition*, Chemical Rubber Publishing Company: Cleveland, Ohio 1968.

17. Cogdell, J. R., *Foundations of Electrical Engineering*, Prentice Hall: Englewood Cliffs, New Jersey, 1990.
18. *The 1989 ARRL Handbook*, The American Radio Relay League, Newington, Connecticut, 1988,
19. Wong, Robert, "Cost Modeling", in *Space Mission Analysis and Design*, ed. J. Wertz and W. Larson, Kluwer Academic Publishers, The Netherlands, 1991.

10.0 Bibliography

Bate, Roger R., Donald D. Mueller, and Jerry E. White, *Fundamentals of Astrodynamics*, Dover Publications, Inc.: New York, 1971.

Bettadpur, Srinivas, ASE Graduate student, University of Texas at Austin, Personal Interview.

Beerer, Joseph G. and Ralph B. Roncoli, "Mars Observer Trajectory and Orbit Design", *Journal of Spacecraft and Rockets*, Sept-Oct 1991, American Institute of Aeronautics and Astronautics, Washington, D.C.

Blume, Bill, Mission Planner Mars Observer JPL, Phone interview.

Braun, R. "Aerodynamic Requirements of a Manned Mars Aerobraking Transfer Vehicle", *Journal of Spacecraft and Rockets*, June 1988.

Burgess, Eric, *Return to the Red Planet*, Columbia University Press, New York, 1990, p. 137.

Chicarro, A.F., et al, "MARSNET Report on the Assessment Study", ESA Publication SCI(91), 6 January 1991.

Conolly, John, Lunar and Mars Exploration Office, Phone Interview.

Covault, Craig, "U.S. Satellite Launch to Renew Mars Exploration" in *Aviation Week and Space Technology*, Aug. 17, 1992, p. 42.

Dubrawsky, Ido, "Design of an Unmanned Robotic Mission to Mars", Master's Thesis, University of Texas at Austin College of Engineering, May 1992.

Esposito, Pasquale and Duane Roth, "Mars Observer Orbit Determination Analysis", *Journal of Spacecraft and Rockets*, American Institute of Aeronautics and Astronautics, Washington, D.C., Sept-Oct 1991.

Fenlason et al., "A Phobos Industrial Production and Supply Base", UT-Austin, Dec. 8, 1986.

Fowler, Dr. Wallace, Professor ASE Department, University of Texas at Austin, Personal Interview.

Griffin and French, "Space Vehicle Design", AIAA, Inc., 1991.

Joels, Kerry M., *The Mars One Crew Manual*, Ballantine Books, 1985.

Johnson, Mark E. "Mars Balloon and Surface Penetrator Design Study," Master's Thesis, University of Texas at Austin College of Engineering, May 1990.

Kaplan, Dave, Lunar and Mars Exploration Office, Phone Interview.

Lewis, John S., "The History of Mars," *The NASA Mars Conference*, American Astronautical Society, 1988.

Lundberg, Dr. John, Professor ASE Department, University of Texas at Austin, Personal Interview.

McKinley, E.L., "Mars Observer Project: An Introduction", *AIAA Journal of Spacecraft and Rockets*, vol. 28, No. 5, 489-490, Sept.-Oct. 1991.

Palocz, Suzanne, "Mars Observer Mission and Systems Overview", *AIAA Journal of Spacecraft and Rockets*, Vol. 28, No. 5, 491-497, Sept.-Oct. 1991.

Report of 90-Day Study on Human Exploration of the Moon and Mars, Task force of NASA for the National Space Council, November 1989.

Robinson, Dr. Paul, Assistant Chief Technologist for JPL, Phone interview on 10/06/92.

Sanso, F. and Rummel, R. *Theory of Satellite Geodesy and Gravity Field Determination* - Notes compiled from a symposium, New York, 1988.

U.S. Congress, Office of Technology Assessment, "Exploring the Moon and Mars; Choices for the Nation," OTA-ISC-502, Washington, DC: U.S. Government Printing Office, July 199.

APPENDICES

APPENDIX A

Trajectory Design Code and Resulting Data

Program to find Hohmann transfer opportunities

```
IMPLICIT DOUBLE PRECISION(A-H,O-Z)
DOUBLE PRECISION MUSUN
DIMENSION XE(3),XEDOT(3),XM(3),XMDOT(3),TEST1(3),TEST2(3)
RTD=180.D0/PI()
AUTOM=1.49599D11
MUSUN=1.32718D20
C
C Get range of launch dates to try
C
WRITE(6,*)'Possible launch dates from JD:'
READ(5,*)UTCLA
WRITE(6,*)'To JD:'
READ(5,*)UTCLB

C
C If 0 input for second date, just look at first date
C
IF(UTCLB.EQ.0.D0)UTCLB=UTCLA
C
C Set up step value (1 day) and tolerances
C
TSTEP=1.D0
ANGTOL=0.5D0
C
C Start iteration
C
200 DO 10 UTCL=UTCLA,UTCLB,TSTEP

C
C Find Earth's position at current launch date
C
CALL SOLAR(XE,XEDOT,UTCL,3)
TEST1(1)=XE(1)
TEST1(2)=XE(2)
TEST1(3)=0.D0
RMAG1=ABV(TEST1)
DO 20 I=1,3
TEST1(I)=TEST1(I)/RMAG1
20 CONTINUE
UTCA=UTCL

C
C Find Mercury's position at launch date
C
CALL SOLAR(XM,XMDOT,UTCA,4)

C
C Just look at projection on ecliptic, and begin propagating
C Mars' position forward by day to find when angle between
C Earth and Mars is 180 degrees.
C
500 TEST2(1)=XM(1)
```

```

TEST2(2)=XM(2)
TEST2(3)=0.D0
RMAG2=ABV(TEST2)
DO 30 I=1,3
  TEST2(I)=TEST2(I)/RMAG2
30 CONTINUE
C
C Find the angle between Earth and Mars
C
  COSANG=DOTP(TEST1,TEST2)
  DIFF=DACOS(COSANG)*RTD
C
C See if angle near 180
C
  IF(DABS(180.D0-DABS(DIFF)).LE.ANGTOL) GOTO 100
C
C Increment arrival date
C
  UTCA=UTCA+TSTEP
C
C Find Mars' position at arrival date
C
  CALL SOLAR(XM,XMDOT,UTCA,4)
  GOTO 500
C
C If found when Earth and Mars directly opposite each other,
C write out time it took
C
100 WRITE(6,*)'TOF at launch date',UTCL,'=',UTCA-UTCL
  WRITE(6,*)'Phase angle=',DIFF
C
C From positions, calculate Hohmann trajectory and TOF
C spacecraft would follow if on this trajectory.
C
  R1=ABV(XE)*AUTOM
  R2=ABV(XM)*AUTOM
  AT=(R1+R2)/2.D0
  TOF=PI()*DSQRT(AT**3/MUSUN)/86400.D0
  WRITE(6,*)'Semi-major axis=',AT
  WRITE(6,*)'Calculated TOF=',TOF
C
10 CONTINUE
C
  STOP
  END

```

Program to calculate Hohmann/BPM trajectory details

```

IMPLICIT DOUBLE PRECISION (A-H,O-Z)
DOUBLE PRECISION MUSUN,MUE,MUM,NMTOFT,KMTOFT
DIMENSION XE(3),XEDOT(3),XM(3),XMDOT(3)
OPEN(9,FILE='PLAN.DAT')
MUSUN=1.32718D20
MUE=3.98603D14
MUM=4.2828D13
RE=6378.D0
RM=3397.D0

```

```

KMTOFT=3280.8D0
AUTOM=1.49599D11
RTD=180.D0/PI()
C
C Get inputs and write to output file
C
WRITE(6,*)'Julian date of launch:'
READ(5,*)TLNCH
WRITE(9,*)'Julian date of launch:',TLNCH
WRITE(6,*)'Time of flight:'
READ(5,*)TOF
WRITE(9,*)'Time of flight:',TOF
C
C Find position of Earth at launch and Mars at arrival
C
TARR=TLNCH+TOF
CALL SOLAR(XE,XEDOT,TLNCH,3)
CALL SOLAR(XM,XMDOT,TARR,4)
C
C Calculate semi-major axis of Hohmann transfer
C
RSUNE=ABV(XE)*AUTOM
RSUNM=ABV(XM)*AUTOM
AT=(RSUNE+RSUNM)/2.D0
WRITE(6,*)'Semi-major axis of transfer:',AT
WRITE(9,*)'Semi-major axis of transfer:',AT
C
C Calculate hyperbolic excess velocity at Earth
C
VEARTH=ABV(XEDOT)*AUTOM/86400.
VINERE=DSQRT(MUSUN*((2.D0/RSUNE)-(1.D0/AT)))
VINFE=VINERE-VEARTH
WRITE(6,*)'V-inf at Earth=',VINFE
WRITE(9,*)'V-inf at Earth=',VINFE
C
C Input altitude of orbit around Earth; then can determine
C delta-V for transfer insertion
C
WRITE(6,*)'Altitude of Earth parking orbit (km):'
READ(5,*)RNOTE
WRITE(9,*)'Altitude of Earth parking orbit (km):',RNOTE
RNOTE=(RNOTE+RE)*1000.D0
VNOTE=DSQRT(VINFE**2+(2.D0*MUE/RNOTE))
WRITE(6,*)'V-not at Earth=',VNOTE
WRITE(9,*)'V-not at Earth=',VNOTE
C
C Calculate departure geometry
C
CALL GEOM('Earth',RNOTE,VNOTE,VINFE,MUE)
C
C Calculate delta-V for transfer insertion
C
VCIRCE=DSQRT(MUE/RNOTE)
WRITE(6,*)'V-circ at Earth=',VCIRCE
WRITE(9,*)'V-circ at Earth=',VCIRCE
DVE=VNOTE-VCIRCE
WRITE(6,*)'Delta-V from LEO=',DVE
WRITE(6,*)

```

```

WRITE(9,*)'Delta-V from LEO=',DVE
WRITE(9,*)
C
C Calculate plane change angle for BPM at true anomaly of
C 90 deg., and delta-V
C
P=(RSUNE*VINERE)**2/MUSUN
WRITE(6,*)P=',P
WRITE(9,*)P=',P
E=DSQRT(1.D0-(P/AT))
WRITE(6,*)E=',E
WRITE(9,*)E=',E
VNINE=DSQRT(MUSUN*((2.D0/P)-(1.D0/AT)))
RMXY=DSQRT(XM(1)**2+XM(2)**2)
DINC=DABS(DATAN(XM(3)/RMXY))
WRITE(6,*)'Plane change required at 90 (deg):',DINC*RTD
WRITE(9,*)'Plane change required at 90 (deg):',DINC*RTD
DVPC=2.D0*VNINE*DSIN(DINC/2.D0)
WRITE(6,*)'Delta-V for plane change=',DVPC
WRITE(6,*)
WRITE(9,*)'Delta-V for plane change=',DVPC
WRITE(9,*)
C
C Calculate hyperbolic excess velocity at Mars
C
VMARS=ABV(XMDOT)*AUTOM/86400.
VINERM=DSQRT(MUSUN*((2.D0/RSUNM)-(1.D0/AT)))
VINFM=VINERM-VMARS
WRITE(6,*)'V-inf at Mars=',VINFM
WRITE(9,*)'V-inf at Mars=',VINFM
C
C Input altitude of final Mars orbit to determine
C delta-V necessary for insertion
C
WRITE(6,*)'Altitude of Mars final orbit (km):'
READ(5,*)RNOTM
WRITE(9,*)'Altitude of Mars final orbit (km):',RNOTM
RNOTM=(RNOTM+RM)*1000.D0
C
C Calculate period
C
PERMRS=2.D0*PI()*DSQRT(RNOTM**3/MUM)
WRITE(6,*)'Period of Mars orbit=',PERMRS/60.D0
WRITE(9,*)'Period of Mars orbit=',PERMRS/60.D0
C
C Calculate inclination for sun-synchronous orbit
C
OMEGAD=1.05851D-7
ORBINC=DACOS(-OMEGAD*2.D0/3.D0/0.001965D0*(RNOTM/1000.D0/RM)**2*
1 PERMRS/(2.D0*PI()))
WRITE(6,*)'Inclination of Mars orbit=',ORBINC*RTD
WRITE(9,*)'Inclination of Mars orbit=',ORBINC*RTD
VNOTM=DSQRT(VINFM**2+(2.D0*MUM/RNOTM))
WRITE(6,*)'V-not at Mars=',VNOTM
WRITE(9,*)'V-not at Mars=',VNOTM
C
C Calculate arrival geometry
C

```

```

CALL GEOM('Mars ',RNOTM,VNOTM,VINFM,MUM)
C
C Calculate delta-V for orbit insertion
C
VCIRCM=DSQRT(MUM/RNOTM)
WRITE(6,*)'V-circ at Mars=',VCIRCM
WRITE(9,*)'V-circ at Mars=',VCIRCM
DVM=VNOTM-VCIRCM
WRITE(6,*)'Delta-V for Mars orbit insertion=',DVM
WRITE(6,*)
WRITE(9,*)'Delta-V for Mars orbit insertion=',DVM
WRITE(9,*)
C
C Determine total delta-V, and delta-V required of spacecraft
C
DVTOT=DVE+DVPC+DVM
DVPER=DVPC+DVM
WRITE(6,*)'Total delta-V:',DVTOT
WRITE(6,*)'Total delta-V required of Percival:',DVPER
WRITE(6,*)
WRITE(9,*)'Total delta-V:',DVTOT
WRITE(9,*)'Total delta-V required of Percival:',DVPER
WRITE(9,*)
C
C Input specific impulse of spacecraft's engines to
C determine final mass ratio
C
WRITE(6,*)'Specific impulse of Percival"s propulsion system:'
READ(5,*)SPIMP
WRITE(9,*)'Specific impulse of Percival"s propulsion system:'
1,SPIMP
RATMAS=EXP(DVPER/(SPIMP*9.81))
WRITE(6,*)'Final mass ratio=',RATMAS
WRITE(6,*)
WRITE(9,*)'Final mass ratio=',RATMAS
WRITE(9,*)
CLOSE(9)
STOP
END
C
C
C
SUBROUTINE GEOM(TITLE,RNOTE,VNOTE,VINFE,MUE)
IMPLICIT DOUBLE PRECISION (A-H,O-Z)
DOUBLE PRECISION MUE
CHARACTER*5 TITLE
RTD=180.D0/PI()
C
C Calculate eccentricity, true anomaly of asymptote, turning angle,
C semi-major axis, and distance from asymptote for escape hyperbola.
C
ECC=1.D0+(RNOTE*VINFE**2)/MUE
THINF=DACOS(-1.D0/ECC)
TRNANG=2.D0*DASIN(1.D0/ECC)
A=-MUE/(VINFE**2)
DELTA=(RNOTE*VNOTE)/VINFE
WRITE(6,*)
WRITE(9,*)

```

```

WRITE(6,*)'*****',TITLE,' escape hyperbola*****'
WRITE(9,*)'*****',TITLE,' escape hyperbola*****'
WRITE(6,*)'Semi-major axis:',A
WRITE(9,*)'Semi-major axis:',A
WRITE(6,*)'Eccentricity:',ECC
WRITE(9,*)'Eccentricity:',ECC
WRITE(6,*)'Delta:',DELTA
WRITE(9,*)'Delta:',DELTA
WRITE(6,*)'Turning angle (deg):',TRNANG*RTD
WRITE(9,*)'Turning angle (deg):',TRNANG*RTD
WRITE(6,*)'True anomaly of asymptote (deg):',THINF*RTD
WRITE(9,*)'True anomaly of asymptote (deg):',THINF*RTD
WRITE(6,*)'*****'
WRITE(9,*)'*****'
WRITE(6,*)
WRITE(9,*)
RETURN
END

```

Program to calculate groundtracks on Mars

```

IMPLICIT DOUBLE PRECISION (A-H,O-Z)
DOUBLE PRECISION MUM
RMARS=3397.D0
MUM=4.2828D13
DTR=PI()/180.D0
OPEN(9,FILE='GROUND.DAT')
C
C Enter type of function to do
C
5  WRITE(6,*)'1) Full, 2) List, 3) Large Prog-VIMS, 4) Quit:'
   WRITE(9,*)'1) Full, 2) List, 3) Large Prog-VIMS, 4) Quit:'
   READ(5,*)ITYPE
   IF(ITYPE.EQ.4)GOTO 99
C
C If full list:
C
   IF(ITYPE.EQ.1)THEN
C
C Input altitude at which information desired
C
   WRITE(6,*)'Altitude of orbit(km):'
   WRITE(9,*)'Altitude of orbit(km):'
   READ(5,*)ALT
C
C Calculate period
C
   PER=2.D0*PI()*DSQRT(((ALT+RMARS)*1000.D0)**3/MUM)
   WRITE(6,*)'Period=',PER/60.D0,' minutes'
   WRITE(9,*)'Period=',PER/60.D0,' minutes'
C
C Caculate number of orbits per day
C
   ORBS=88772.D0/PER
   IORB=INT(ORBS)+1
   WRITE(6,*)'Number of orbits per day:',ORBS,IORB
   WRITE(9,*)'Number of orbits per day:',ORBS,IORB

```

```

C
C Caculate swath angle VIMS has at this altitude
C
  VIMS=0.115703948D0*ALT
  WRITE(6,*)"Swath of VIMS (km):",VIMS
  WRITE(9,*)"Swath of VIMS (km):",VIMS
C
C Caculate range of penetrator
C
  PEN=2.D0*2.144506921D0*ALT
  WRITE(6,*)"Maximum range allowed from penetrator (km):",PEN
  WRITE(9,*)"Maximum range allowed from penetrator (km):",PEN
C
C Caculate distance along equator between consecutive orbits
C
  DORB=(0.0040553D0*PER)*DTR*RMARS
  WRITE(6,*)"Distance groundtrack moves each orbit (km):",DORB
  WRITE(9,*)"Distance groundtrack moves each orbit (km):",DORB
C
C Caculate distance along equator between passes on
C consecutive days
C
  TIMDAY=DBLE(IORB)*PER
  DANGLE=(0.0040553D0*TIMDAY)-360.D0
  DGRND=DANGLE*DTR*RMARS
  WRITE(6,*)"Distance groundtrack moves west each day (km):",DGRND
  WRITE(9,*)"Distance groundtrack moves west each day (km):",DGRND
C
C Caculate distance between passes of short-distance repeat cycle
C
  GRNDS=DORB/DGRND
  IGRND=INT(GRNDS)+1
  DVIMS=(DBLE(IGRND)*DGRND)-DORB
  IF(DVIMS.GT.100.D0)DVIMS=DVIMS-DGRND
  WRITE(6,*)"VIMS" distance (km):",DVIMS
  WRITE(9,*)"VIMS" distance (km):",DVIMS
C
  REPEAT=DGRND/ABS(DVIMS)
C
  WRITE(6,*)"Number of days for complete mapping cycle:",REPEAT
C
  WRITE(9,*)"Number of days for complete mapping cycle:",REPEAT
C
C If lists of vital information for several altitudes desired:
C
  ELSEIF(ITYPE.EQ.2)THEN
  WRITE(6,*)"Starting altitude (km):"
  READ(5,*)ALTST
  WRITE(6,*)"Final altitude (km):"
  READ(5,*)ALTFN
  DO 10 ALT=ALTST,ALTFN,1.D0
    PER=2.D0*PI()*DSQRT(((ALT+RMARS)*1000.D0)**3/MUM)
    ORBS=88772.D0/PER
    VIMS=0.115703948D0*ALT
    PEN=2.D0*2.144506921D0*ALT
    DORB=(0.0040553D0*PER)*DTR*RMARS
    IORB=INT(ORBS)+1
    TIMDAY=DBLE(IORB)*PER
    DANGLE=(0.0040553D0*TIMDAY)-360.D0
    DGRND=DANGLE*DTR*RMARS
    WRITE(6,*)" Altitude (km):",ALT

```

```

        WRITE(6,*)'Distance groundtrack moves each orbit (km):',DORB
        WRITE(6,*)'Distance groundtrack moves west each day (km):',DGRND
10    CONTINUE
C
C If lists for several altitudes desired in order to find good
C short-distance repeat cycles
C
    ELSEIF(ITYPE.EQ.3)THEN
        WRITE(6,*)'Starting altitude (km):'
        READ(5,*)ALTST
        WRITE(6,*)'Final altitude (km):'
        READ(5,*)ALTFN
        DO 20 ALT=ALTST,ALTFN,.1D0
            PER=2.D0*PI()*DSQRT(((ALT+RMARS)*1000.D0)**3/MUM)
            ORBS=88772.D0/PER
            VIMS=0.115703948D0*ALT
            PEN=2.D0*2.144506921D0*ALT
            DORB=(0.0040553D0*PER)*DTR*RMARS
            IORB=INT(ORBS)+1
            TIMDAY=DBLE(IORB)*PER
            DANGLE=(0.0040553D0*TIMDAY)-360.D0
            DGRND=DANGLE*DTR*RMARS
            GRNDS=DORB/DGRND
            IGRND=INT(GRNDS)+1
            DVIMS=(DBLE(IGRND)*DGRND)-DORB
            WRITE(6,*)'Altitude (km):',ALT
            WRITE(6,*)'Distance groundtrack moves each orbit (km):',DORB
            WRITE(6,*)'Distance groundtrack moves west each day (km):',DGRND
            WRITE(6,*)'"VIMS" distance (km):',DVIMS
20    CONTINUE
        ENDIF
        GOTO 5
99    STOP
    END

```

Hohmann Output Data

Julian date of launch:	2450416.00
Time of flight:	254.00 days
Semi-major axis of transfer:	1.8670514293D+011 km
V-inf at Earth=	2791.45700209158 km/s
Altitude of Earth parking orbit :	185.0000 km
V-not at Earth=	11369.344171054200 km/s

*****Earth escape hyperbola*****

Semi-major axis:	-5.115389147D+007 km
Eccentricity:	1.128299134458780
Delta:	2.67304872468D+007
Turning angle :	124.8213265086500 deg
True anomaly of asymptote :	152.4106632543250 deg

V-circ at Earth=	7793.258454759390 km/s
Delta-V from LEO=	3576.085716294780 km/s

P=	1.78500852649D+011
E=	0.209624658694674
Plane change required at 90 (deg):	0.529605136990626
Delta-V for plane change=	257.5200606530690

V-inf at Mars=	-2800.80238948
Altitude of Mars final orbit (km):	179.40000
Period of Mars orbit=	108.2265589
Inclination of Mars orbit=	92.35772239
V-not at Mars=	5638.6909074

*****Mars escape hyperbola*****

Semi-major axis:	-5459625.549319550
Eccentricity:	1.655063239720850
Delta:	-7200156.011446760
Turning angle (deg):	74.3435304598782
True anomaly of asymptote (deg):	127.1717652299390

V-circ at Mars=	3460.51593878382
Delta-V for Mars orbit insertion=	178.17496869507

Total delta-V:	6011.78074564293
Total delta-V required of Percival:	2435.69502934814

Specific impulse of Percival's propulsion system:	289.900
Final mass ratio=	2.35480331874

Groundtrack Output Data

Altitude of orbit:	179.4 km
Period:	108.227 minutes
Number of orbits per day:	13.670
Swath of VIMS :	20.757 km
Maximum range allowed from penetrator :	769.449 km
Distance groundtrack moves each orbit :	1561.280 km
Distance groundtrack moves west each day :	513.9498 km
'VIMS' distance :	-19.4310 km

APPENDIX B

Penetrator Emplacement and Stress Analysis Method

The following analysis was taken from Mars Balloon and Surface Penetrator Study by Mark E. Johnson. The equations and empirical data were originally developed at Sandia National Laboratories. Given the dimensions and mass of a penetrator, soil characterization, and an impact velocity, the depth of penetration, the maximum accelerations, and the maximum stresses present in the penetrator walls can be calculated. Equations are also given for the calculation of critical stresses for Euler column buckling and local wall crippling.

The equation used to predict the depth of penetration is as follows:

$$d_n = 0.0117K_n S_n N_n \sqrt{M/A} (V_n - 30.5)$$

where d_n is the penetration depth (m), K_n is the low-mass scaling coefficient, S_n is the characteristic soil coefficient, N_n is the nose performance coefficient, M/A is the mass-to-cross-sectional area ratio (kg/cm^2), and V_n is the impact velocity.

The subscripts allow for differing soil characteristics and different penetrator mass and cross-sectional areas. Each "layer" calculation represents a layer of homogeneous soil or a thickness through which the penetrator's cross-sectional area and mass are the same. The soil will be assumed to be homogenous for all calculations. Thus, each calculation represents a different section or configuration of the penetrator.

Three penetration calculations are necessary for the fore and aft design of the penetrator. The first determines the penetration of the penetrator before the aft section separation. This calculation ensures that the depth of penetration is enough to cause the fore and aft sections to separate (d_n must be greater than the length of the forebody). If d_n is greater than the forebody length, the initial penetration is set equal to the forebody length. The second calculation determines the depth of the forebody after the aft section separates. The last

calculation determines the depth of penetration of the aft section. The final depth of penetration of the forebody is the sum of the first two depth calculations.

The low-mass scaling coefficient is determined from the graph shown in Figure B.1. The nose performance coefficients are determined from Table B.1. Guidelines for the choice of soil coefficients are given in Table B.2. The shaded region indicates the soil characteristics considered by the Percival project. The data in these graphs and tables was empirically developed at Sandia National Laboratories.

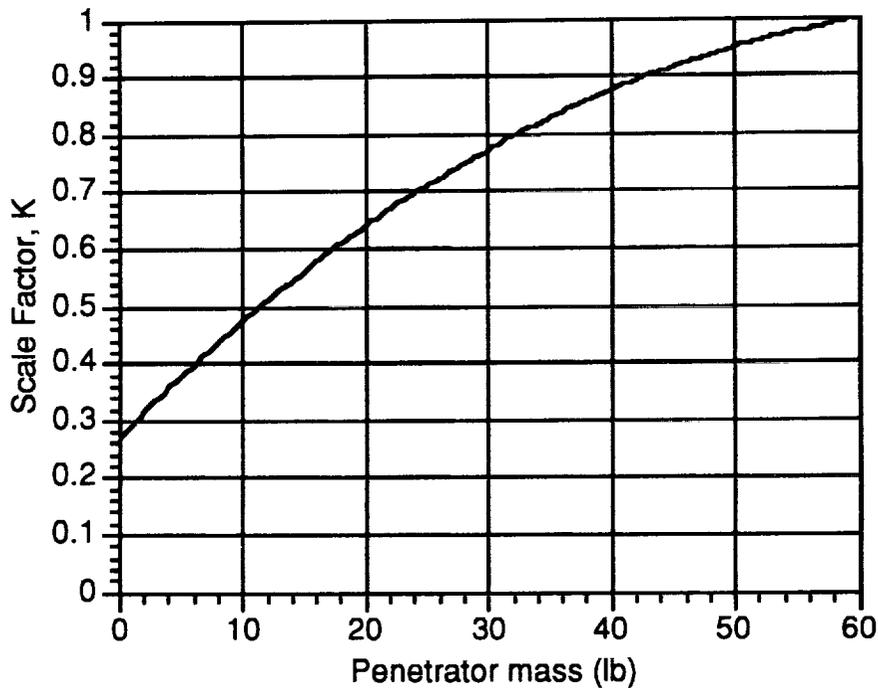

Figure B.1 Low-mass scaling coefficients

Table B.1 Nose Performance Coefficients, N

Nose Shape	Caliber (dia, in.)	N
Flat	-	0.56
Hemisphere	0.5	0.65
Cone	1.0	0.82
	2.0	1.08
	3.0	1.33
Tangent Ogive	1.4	0.82
	2.0	0.92
	2.4	1.00
	3.0	1.11
	3.5	1.19
Inverse Ogive	2.0	1.03
	3.0	1.32
Step Cone		1.28
Biconic	3.0	1.31

Table B.2 Characteristic Soil Coefficients, S

Coefficient	Description
0.2 - 1	Massive medium to high-strength rock, with few fractures; Concrete, 2-5 ksi, reinforced.
1 - 2	Silt or clay, frozen, saturated, very hard; Rock, weathered, low-strength, fractured; Sea or freshwater ice more than 10 feet thick.
2 - 3	Massive gypsite deposits; Sand and gravel, coarse, well-cemented; Caliche, dry; Silt or clay, frozen, moist.
4 - 6	Sea or freshwater ice from 1 to 3 feet thick; Sand, medium to coarse, medium dense, no cementation, wet or dry; Silt or clay, hard, dry, dense; Desert alluvium.
8 - 12	Fine sand, very loose, excluding topsoil; Silt or clay, moist, stiff, medium dense, less than about 50% sand.
10 - 15	Topsoil, moist, loose with some clay or silt; Clay, moist, medium stiff and dense, with some sand.
20 - 30	Topsoil, loose, moist, with humus material, mostly sand and silt, soft, low shear strength.
40 - 50	Topsoil, very loose, dry, sandy; Silt or clay, saturated, very soft, low shear strength, high plasticity; Wet lateritic clays.
100	Snow, loose.

For each new calculation beyond the first, the new initial "impact" velocity must be determined. This velocity can be found using the acceleration and velocity equations shown below:

$$a_n = \frac{V_n^2}{2gd_n}$$

where a_n is the deceleration over the penetration (m/s^2), V_n is the impact velocity for the previous layer (m/s), and d_n is the penetration depth or "thickness" of the layer (m). Experiments done at Sandia National Laboratories have shown that the deceleration due to penetration is essentially a step

function rather than an impulse function. Thus, the deceleration is considered to be constant for each layer calculation. The new initial velocity is given by:

$$V_n = \sqrt{V_{n-1}^2 - 2ga_{n-1}\left(T_{n-1} - \frac{L_{n-1}}{2}\right)}$$

where V_{n-1} is the initial velocity for the previous layer (m/s), a_{n-1} is the acceleration through the previous layer (m/s^2), T_{n-1} is the thickness of the previous layer (m), L_{n-1} is the length of the previous Penetrator section's nose (m).

Stress Analysis

The following analysis examines the two primary expected failure modes for a penetrator: Euler column buckling and local wall crippling. For each failure mode, the highest stress experienced within the penetrator wall is used for comparison. The following equation gives the maximum stress:

$$\sigma_{\max} = \frac{m_{\max} a_{\max}}{A_{\text{wall}_{\min}}}$$

where σ_{\max} is the maximum stress (MPa), m_{\max} is the largest mass that the penetrator section must support (kg), a_{\max} is the largest acceleration that the penetrator section experiences, and $A_{\text{wall}_{\min}}$ is the minimum cross-sectional area of the penetrator wall.

The critical stress for Euler column buckling is given by the following:

$$\sigma_c = \frac{\pi^2 E}{\left(\frac{L}{r}\right)^2}$$

where σ_c is the critical stress (MPa), E is the Young's modulus for the material (MPa), L is the longest column length (m), and r is the minimum radius of gyration of the cross-section (m).

The critical stress for local wall crippling is a characteristic of the material used. For titanium, the following equations were used to estimate the allowable stress before onset of local wall crippling:

$$\sigma_c = 205$$

$$L/r \leq 10$$

$$\sigma_c = 222 - 1.7\left(\frac{L}{r}\right)$$

$$10 \leq L/r \leq 54$$

$$\sigma_c = 380 \times \frac{10^3}{\frac{L}{r}}$$

$$L/r \geq 54$$

where L and r are defined as above.

APPENDIX C
Cost Summaries

Personnel Cost

Personel Cost: Progress Report Summary																				
	Week 2			Week 3			Week 4			Week 5			Week 6			Week 7			Total Cost (wk 1-7)	
	Adm.	Eng.	Total	Adm.	Eng.	Total	Adm.	Eng.	Total	Adm.	Eng.	Total	Adm.	Eng.	Total	Adm.	Eng.	Total	Actual	Proposed
David Reed \$25/hr	20	4	24	29	4	33	20	2	22	27	2	29	27	2	29	10	4	14	\$3,775	\$3,850
Stewart Lilley \$22/hr	15	5	20	6	12	18	6	12	18	6	12	18	6	12	18	8	2	10	\$2,244	\$2,772
Meiinda Sirman \$17/hr(2-6)\$22/hr(6-)		2	2		6	6		15	15		12	12	3	10	13	4	8	12	\$1,080	\$1,428
Paul Bolton \$17/hr		8	8		7	7		3	3		12	12		12	12		15	15	\$969	\$1,428
Susan Elliott \$17/hr		10	10		10	10		8	8		5	5		15	15		7	7	\$935	\$1,428
Doug Hamilton \$17/hr		6	6		12	12		12	12		12	12		12	12		12	12	\$1,122	\$1,428
Jim Nickelson \$22/hr(2-6), \$17/hr(6-)	10	9	19	6	9	15	6	0	6	6	12	18	20	0	20		5	5	\$1,920	\$2,772
Artemus Shelton \$17/hr		5	5		8	8		12	12		12	12		12	12		4	4	\$901	\$1,428
Total Hours			94			109			96			118			131			79	\$12,946	\$16,534
	Week 8			Week 9			Week 10			Week 11			Week 12			Week 13			Total Cost 1-13 Week	
	Adm.	Eng.	Total	Adm.	Eng.	Total	Adm.	Eng.	Total	Adm.	Eng.	Total	Adm.	Eng.	Total	Adm.	Eng.	Total	Actual	Proposed
David Reed \$25/hr	11	7	18	17	4	21	25	6	31	6	15	21	16	8	24	14	0	14	\$7,000	\$7,150
Stewart Lilley \$22/hr	3	5	8	3	3	6	4	6	10	2	18	20	4	22	26	0	4	4	\$3,872	\$5,148
Meiinda Sirman \$17/hr(2-6), \$22/hr(6-)	2	10	12	10	15	25	10	5	15	7	3	10	10	12	22	5	0	5	\$3,038	\$3,804
Paul Bolton \$17/hr		11	11		6.5	6.5		8	8		24	24		26	26		0	0	\$2,253	\$2,652
Susan Elliott \$17/hr		8	8		10	10		10	10		8	8		8	8		0	0	\$1,683	\$2,652
Doug Hamilton \$17/hr		15	15		16	16		6	6		15	15		12	12		5	5	\$2,295	\$2,652
Jim Nickelson \$22/hr(2-6), \$17/hr(6-)		11	11	0	10	10		15	15	0	13	13	0	15	15	0	2	2	\$3,042	\$3,996
Artemus Shelton \$17/hr		7	7		8	8		8	8		4	4		6	6		8	8	\$1,598	\$2,652
Total Hours			90			103			103			115			139			38	\$24,781	\$30,706

Preliminary Design Cost Estimate

Prliminary Design Cost Estimate						
Space Segment Cost:	Parameter:	RDT&E Cost: (\$K)	Dev. Factor	RDT&E*Dev. Factor	TFU Cost: (\$K)	Preliminary Total Cost Estimate (\$K)
Gradiometer*:	Enabling Tech.	-	1	-	-	= 50000
VIMS:	Aperature (m)	169649.533	0.1	16964.9533	67860.3417	84825.29502
Balloon Relay System:	Wt (kg)	3355.89771	0.1	335.589771	780.18277	1115.772541
Penetrators*:	Enabling Tech.	-	1	-	-	= 50000
Communications:	Wt (kg)	4691.86375	0.2	938.37275	1082.40962	2020.78237
Structure/Thermal:	Wt (kg)	16490.9688	0.2	3298.19376	2698.53981	5996.733574
GN&C:	Dry Wt (kg)	19743	0.3	5922.9	5966.68698	11889.58698
Power:	EPS Wt x BOL	7228.7449	0.2	1445.74898	3358.50058	4804.249559
Modified Delta 7925:	-	-	-	-	60000	60000
Totals:		221160.009		28905.7586	141746.661	270652.42