

N94-25105

# ON-LINE EVALUATION OF MULTILoop DIGITAL CONTROLLER PERFORMANCE

Carol D. Wiseman  
NASA Langley Research Center

NASA LaRC Workshop on Guidance, Navigation,  
Controls, and Dynamics of Atmospheric Flight  
NASA Langley Research Center  
March 18 - 19, 1993

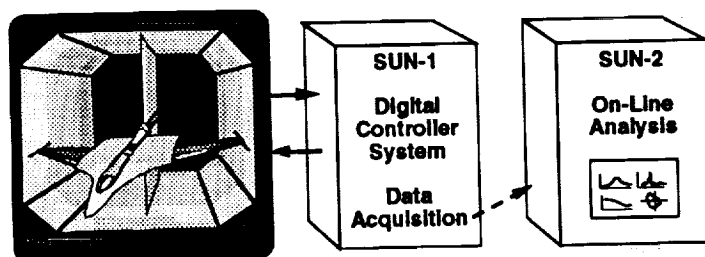

The purpose of this presentation is to inform the Guidance and Control community of capabilities which were developed by the Aeroservoelasticity Branch to evaluate the performance of multivariable control laws, on-line, during wind-tunnel testing. The capabilities are generic enough to be useful for all kinds of on-line analyses involving multivariable control in experimental testing. Consequently, it was decided to present this material at this workshop even though it has been presented elsewhere.

I want to acknowledge the other participants in the development of these capabilities. They were:

Sheri Hoadley and Vivek Mukhopadhyay of NASA Langley Research Center and  
Tony Pototzky and Sandra McGraw of Lockheed Engineering and Sciences  
Company

The capabilities are summarized for our application in the bottom figure. Our test involved a wind-tunnel model and two computers, the first was a digital controller where data acquisition was performed and then the data was transferred via ethernet to another computer where the on-line analyses were performed. I will be tell more about this on the next chart

## BACKGROUND

### AFW Controller Performance

- Active Flexible Wing (AFW)
- Analysis During Test
  - Safety
  - Efficient Use of Test Time

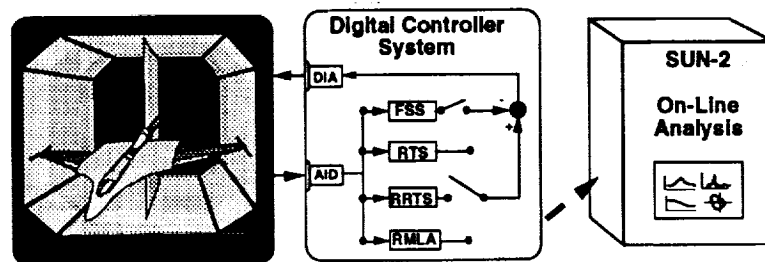

First, I want to provide you with some background for why we developed these analysis capabilities. One major objective of the Active Flexible Wing Program was to verify control law design methodologies by testing flutter suppression control laws in conjunction with rolling maneuver control laws. These are summarized in the middle box which represents the digital controller. FSS is flutter suppression. There were 3 roll control laws, any one of which could be operating at a time in conjunction with Flutter Suppression. These three control laws were Roll Trim System, Rolling Maneuver Load Alleviation and Roll Rate Tracking System.

The AFW had multiple control surfaces as well as multiple sensors, thus allowing for multivariable control laws.

In order to protect the model and tunnel from unnecessary damage and to make optimum use of limited wind-tunnel test time, it was essential to be able to evaluate the controller performance, on-line, during the wind tunnel test.

To provide this capability, necessary data was acquired by the digital controller and immediately sent to another computer for on-line analysis via ethernet.

## ESSENTIAL ON-LINE ANALYSIS REQUIREMENTS

- BEFORE AND DURING TESTING VERIFY
  - CONTROL LAWS
- BEFORE CLOSING LOOP PREDICT
  - IF CONTROL LAW WILL DESTABILIZE SYSTEM
  - STABILITY MARGINS
- AFTER CLOSING LOOP DETERMINE
  - STABILITY MARGINS
  - CONTROL SURFACE ACTIVITY
  - OPEN-LOOP FLUTTER BOUNDARY

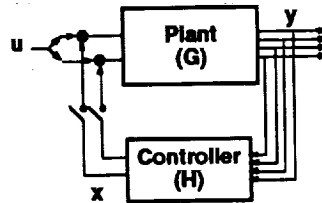

Specifically, there were three essential requirements. First, it was necessary to verify the correct execution of control laws both before and during testing. The diagram to the right depicts the controller/plant system in which the AFW plant is depicted by the rectangle labeled G and the Controller is depicted by the rectangle labeled H.

y are the outputs of the plant which correspond to accelerometer measurements and in some cases strain gauge measurements.

x are the control law outputs or the commands to the control surfaces which are sent to the model.

u are the excitations which can be added to the control law commands or to the sensors.

The second requirement was that during open-loop testing in which the control law commands are not sent to the model, it was essential to predict, before closing the loop, whether a control law would destabilize the system and what the margin of stability would be once the loop was closed. If the control law was predicted to destabilize the system or the margin of stability was predicted to be unsatisfactory, the loop on the control law would not be closed thus preventing the model and the wind-tunnel from damage.

The third requirement was that during closed-loop testing in which the control law commands are sent to the model, it was essential to evaluate the performance of the control law in order to guide the wind-tunnel test engineers in determining whether testing of that control law could continue to other test conditions. To do this, measures of stability margins and control surface activity were needed. It was also necessary to determine if the closed-loop system was above the open-loop flutter boundary.

## ON-LINE ANALYSIS CAPABILITIES

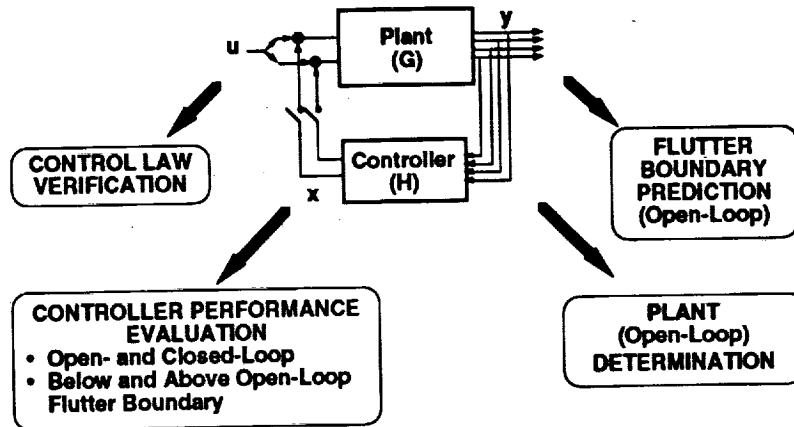

These three requirements were met with the development for four major areas of analyses capabilities depicted in this figure. They were:

first, control law verification by which correct execution of control laws could be assessed using both time and frequency domain analyses;

second, controller performance evaluation in both the time and frequency domain through which controller performance could be determined; performance was evaluated both open and closed-loop and both below and above the flutter boundary.

third, open-loop plant determination, and

fourth, open-loop flutter boundary predictions.

These last two analysis capabilities are performed using frequency domain techniques only and are by-products of frequency domain CPE.

All capabilities are for multi-variable or multi-loop control systems. Let me emphasize that the capabilities available are applicable to both stable and unstable plants as long as the overall system is stable, that is to say if we are testing open-loop the open-loop system must be stable, if closed-loop the closed-loop system must be stable. The capabilities were met by the software developed which will be described on the following slide

## ON-LINE ANALYSIS SOFTWARE

	c	Fortran	Matlab script
• DATA INTERFACE PROGRAMS	√		
• TIME HISTORY PLOTS			√
• RMS CALCULATIONS		√	√
• FOURIER ANALYSIS		√	
• MATRIX OPERATIONS			√
• ASSOCIATED PLOTS			√

The following software modules were developed to support the analyses and are available for use by others:

- Data interface programs, coded in C, converted binary test data (from AID converters) to scaled and formatted data for use in Fourier Analysis codes and MATLAB, for plotting or other calculations. Additional data interface programs written in c converted the output of the Fourier analysis package to matlab format.
- MATLAB script files for plotting time history and frequency domain data.
- MATLAB script files for calculating RMS of time history data, and also plotting the RMS as a function of dynamic pressure
- Fourier Analysis Package, coded in Fortran, which calculates transfer functions of any of the outputs to the excitation. This software uses an array processor and has many capabilities of windowing and overlap averaging.
- MATLAB script files which perform all matrix operations needed to calculate stability margins and determine open-loop plant stability, as well as determine the plant transfer matrix from the open- or closed-loop system transfer matrices.
- MATLAB script files to generate all associated plots.

## ON-LINE ANALYSIS CAPABILITIES

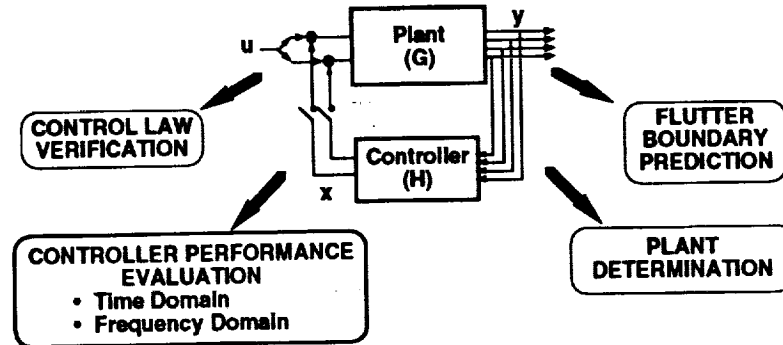

- **DATA INTERFACE PROGRAMS**
- **TIME HISTORY PLOTS**
- **RMS CALCULATIONS**
- **FOURIER ANALYSIS**
- **MATRIX OPERATIONS**
- **ASSOCIATED PLOTS**

In this presentation, I am only going to elaborate on the frequency-domain controller performance and plant determination capabilities which use the data interface programs, the Fourier analysis package, and the MATLAB script files which performed required matrix operations and generated associated plots.

## FREQUENCY DOMAIN CPE PROCEDURES

- Input Excitation,  $u$ , Into each Control Surface
- Measure Time Responses of each Output  $x$  and  $y$
- Perform Fast Fourier Transforms of  $u$ ,  $x$ , and  $y$
- Compute Power and Cross Spectra
- Compute Transfer Functions
- Construct Plant ( $G$ ), Controller ( $H$ ), and Return-difference Matrices ( $I+HG$ , and  $I+GH$ )
- Compute Singular Values for Evaluating Robustness to Multiplicative and Additive Uncertainties
- Compute Determinants for Plant Stability Evaluation

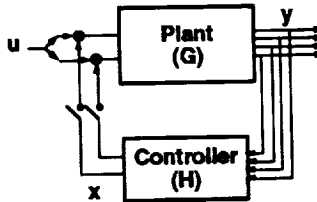

The following slide outlines the procedure to evaluate controller performance of a multi-loop controller in the frequency domain.

An excitation is input to one control surface at a time. The time responses of each output of the plant (accelerometers and strain gauges used by the controller) and controller commands are measured. The transfer functions of these outputs and commands with respect to the excitation are calculated by performing Fast Fourier transforms of  $u$ ,  $x$ , and  $y$  and computing the power and cross spectra. The next and each control surface is excited in turn and the transfer functions are calculated for these signals. The transfer functions are then combined into transfer matrices. The Plant ( $G$ ), Controller ( $H$ ) and the return-difference matrices are constructed or computed. The singular values are computed in order to evaluate the robustness to multiplicative at the plant input and output points and additive uncertainties. The determinants are also computed to be used for evaluating plant stability.

The evaluation of the performance of multivariable controllers using excitations into the sensors instead of the control surface has also been developed and is available to handle the case of the overdetermined problem.

The following slide shows an example of actual results obtained during the wind-tunnel test.

## CONTROLLER PERFORMANCE EVALUATION FREQUENCY-DOMAIN FLUTTER SUPPRESSION

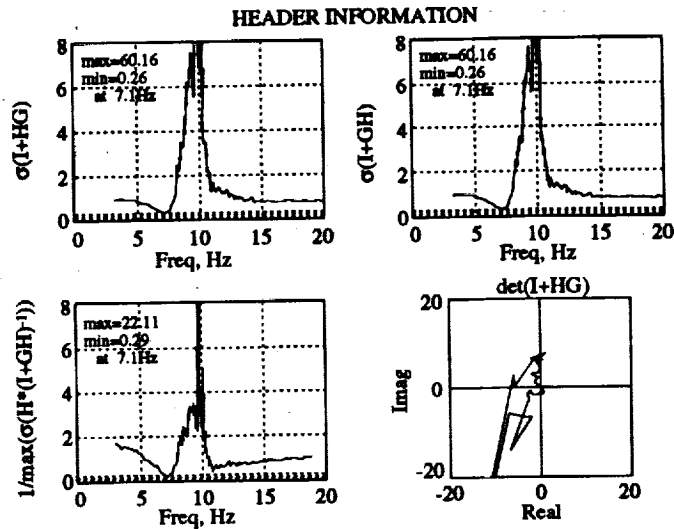

This slide is an example of the plot output from the CPE Analysis package. This is an actual plot of results that could be seen in the tunnel control room within about a minute from the completing the required data acquisition and could then be printed on a laserprinter in the control room. This data was used to aid in determining if we would go to the next test condition.

The top two plots are minimum singular values of the return-difference matrices. These provide measures of robustness to multiplicative uncertainties at both the plant input and plant output points. The closer the curve comes to zero, the closer the system is to being unstable. The minimum singular values are related to combined gain and phase margins for a multivariable system.

The dashed lines at the bottom of the plots display required levels of stability which allow a quick assessment of the stability margins due to multiplicative errors in the plant inputs or plant outputs.

The lower left depicts the margin of stability to an additive plant uncertainty. The lower right indicates whether the open-loop plant is stable or not. For these particular plots for a stable closed-loop system, the open-loop plant is unstable as indicated by an encirclement of the critical point at the origin which can be seen when the plot is magnified. The capability of enlarging this determinant plot to better identify encirclements was also available.

In all cases, the stability margins are the actual margins not conservative estimates because they are based on the actual plant. When performing open-loop analyses, if the method predicts that the closed-loop system is unstable, it is unstable.



## ON-LINE ANALYSIS CAPABILITIES

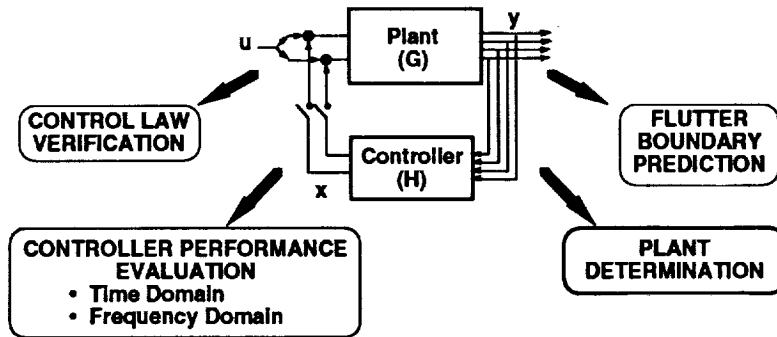

- DATA INTERFACE PROGRAMS
- TIME HISTORY PLOTS
- RMS CALCULATIONS
- FOURIER ANALYSIS
- MATRIX OPERATIONS
- ASSOCIATED PLOTS

Another capability that I wanted to elaborate on in this presentation was the determination of the open-loop plant. This capability also involved the data interface programs, the Fourier Analysis package, the matrix operations and associated plot routines.

## PLANT DETERMINATION

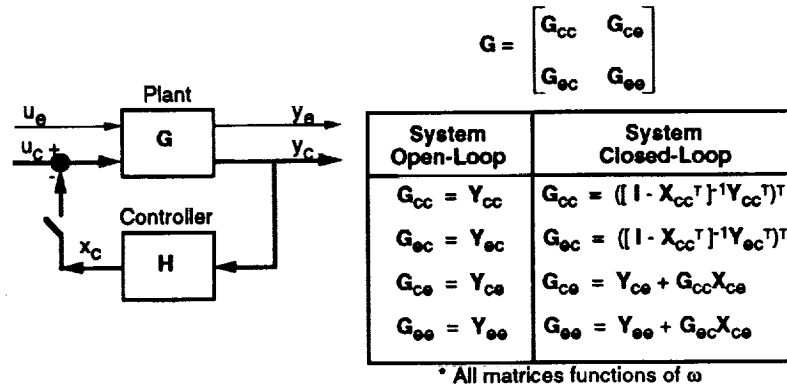

Part of the plant determination was a by-product of the CPE codes. This part is denoted as  $G_{cc}$  in the plant transfer matrix,  $G$ . Here the subscript  $c$  refers to the control surfaces actuated by the control laws and sensors used by the specified control law. The other control surfaces are denoted by a subscript  $e$ , for external. All of the control surfaces both used by the control law and those external to the control law were excited one at a time. The transfer functions of the outputs  $y$  and the control law commands  $x$  with respect to the excitation were calculated. The rest of the plant transfer matrix was then obtained using the equations in the lower right where the capital  $X$  and  $Y$  refer to transfer matrices of the control law outputs and plants with respect to the excitations.

When the system is open-loop, ie when the control law commands are not sent to the model, the equations are shown in the first column.

When the system is closed loop, the commands are sent to the model. The equations to obtain the entire plant transfer matrix are shown in the second column.

The transfer function calculations and matrix operations required to obtain the entire plant transfer matrix are also available in the on-line analysis package. The capital letters correspond to transfer matrices.

## **CONCLUDING REMARKS**

### **ON-LINE ANALYSIS CAPABILITIES FOR MULTI-VARIABLE CONTROL**

- **Developed**
- **Available**

### **WHICH PERFORM DURING TESTING:**

- **Control Law Verification**
- **Control Law Performance Evaluation**
- **Open-loop Plant Determination**
- **Stability Boundary (Flutter) Prediction**

The capability to evaluate the performance of multivariable control laws on-line during experimentation has been developed and is available. These capabilities perform during testing, control law verification, evaluation of performance of the control laws, determination of the open-loop plant and stability boundary prediction which in our application was flutter.

## TECHNOLOGY TRANSFER

- **Presentations/Publications**
  - American Control Conference, 1990**
  - 4th Workshop on Comp. Control of Flex. Aerospace Systems, 1990**
  - Guidance and Control Conference, 1990**
  - Aerospace Flutter and Dynamics Council Meeting, 1991**
  - Dynamic Specialist Conference, 1992**
  - DSP Exposition and Symposium, 1992**
  - Journal of Guidance, Control and Dynamics, 1992**
  - FUTURE: ACAD Press Chapter, NASA Tech Brief, Journal of Aircraft**
- **Spacecraft Dynamics Branch - Large Space Structures Application**
- **NASA Dryden Research Facility - X-29 Flight Test**

There is no users manual for the software but both the theory and results for different aspects of the on-line analysis capabilities have been documented and presented at a variety of conferences over a period of 3 years from 1990-1992. These documents and the software are available to anyone interested. The software has been provided to the Spacecraft Dynamics Branch for use in a large space structures application and the theory and equations were used by Dryden Flight Research Facility to support the X-29 flight test.

If you would like to obtain the software or more information, I'll give you my business card.

# Fuzzy Logic Helicopter Control

By

Captain Gregory W. Walker

NASA Langley Research Center  
Aeroflight Dynamics Directorate  
U.S. Army Aviation Troop Command  
Hampton, VA 23665-5225

Presented at the  
First Annual LaRc Workshop on Guidance, Navigation, Controls, and  
Dynamics for Atmospheric Flight  
H.J.E. Reid Conference Center  
March 18-19 1993

NASA / US Army

**SLIDE 1:** This work is an outgrowth of a project that is being jointly developed by the U.S. Army Aviation Troop Command's Aeroflight Dynamics Directorate and the NASA Langley Research Center.

## OUTLINE OF PRESENTATION

- An Overview Of The Free Flight Rotorcraft Program
- Why This Program Is Looking At Fuzzy Logic Control
- Professor Sugeno's (Tokyo Institute of Technology) "Fuzzy Control of Unmanned Helicopters" Project
- Current Status



**SLIDE 2:** There is cooperating work going on between this project and Professor Sugeno. NASA nor the Army has Sugeno under any contract or grant, the cooperation is merely an exchange of ideas and flight data.

### PROGRAM OBJECTIVE

Evaluate the use of wind-tunnel rotor systems on powered free-flying helicopter models to supplement full-scale flight testing.

- Reduce direct operating costs
- Elimination of manned-flight safety issues
- Reduced turn-around time



SLIDE 3: The program that this fuzzy logic work grew out of is the "Free Flight Rotorcraft Research Vehicle (FFRRV) Project". This is the objective of the FFRRV project, not specifically the "Fuzzy Logic" work.

### THE TOOLKIT

Although motivated by maneuverability, agility, and detectability concerns, the free-flight rotorcraft test technique is being developed as a general research tool to supplement wind tunnel and simulation studies.

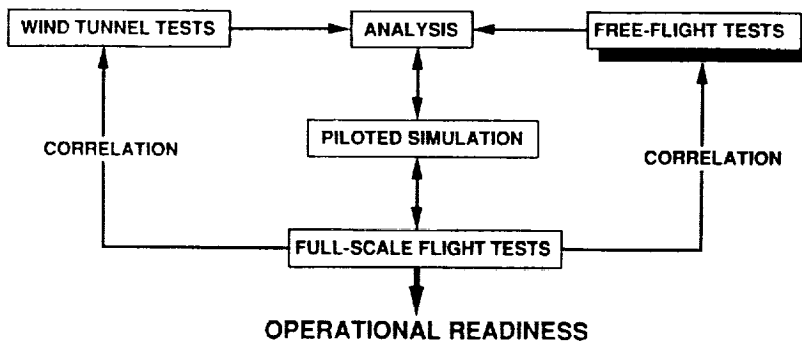

SLIDE 4: The FFRRV project will not supplant full scale flight testing, merely supplement it. The fixed wing community has had the ability to do dynamic studies at model scale for years, we are trying to bring such a capability to rotorcraft.

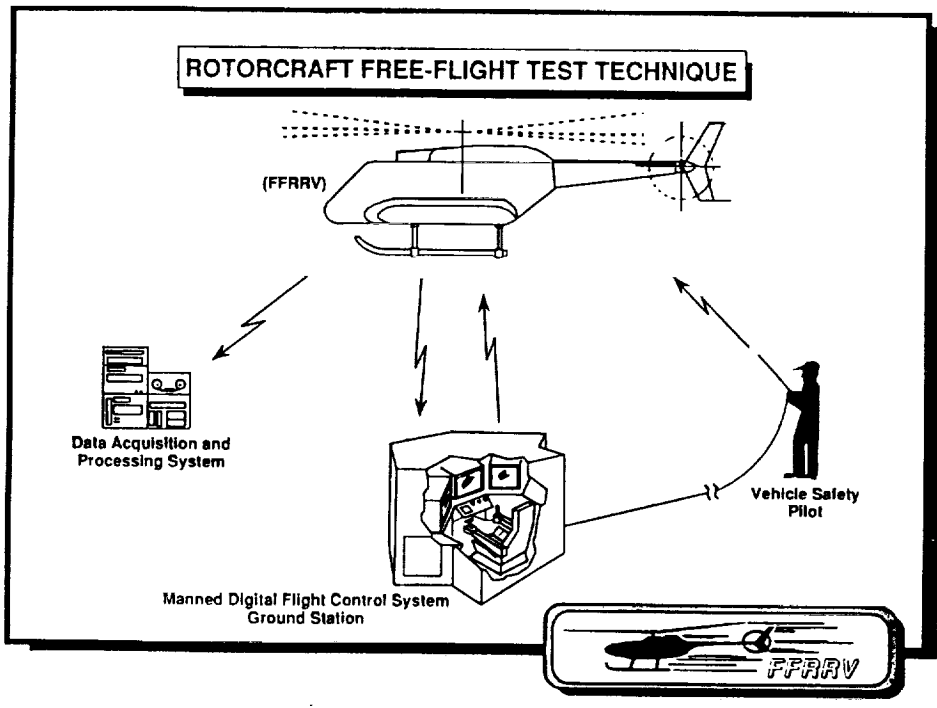

**SLIDE 5:** This slide depicts the test technique we are using to evaluate rotorcraft aerodynamics with FFRRV. The pilot sits in a ground based cockpit but perceives to be in the model via telepresence. The vehicle safety pilot has overall authority to interrupt the control system and terminate any experiment.

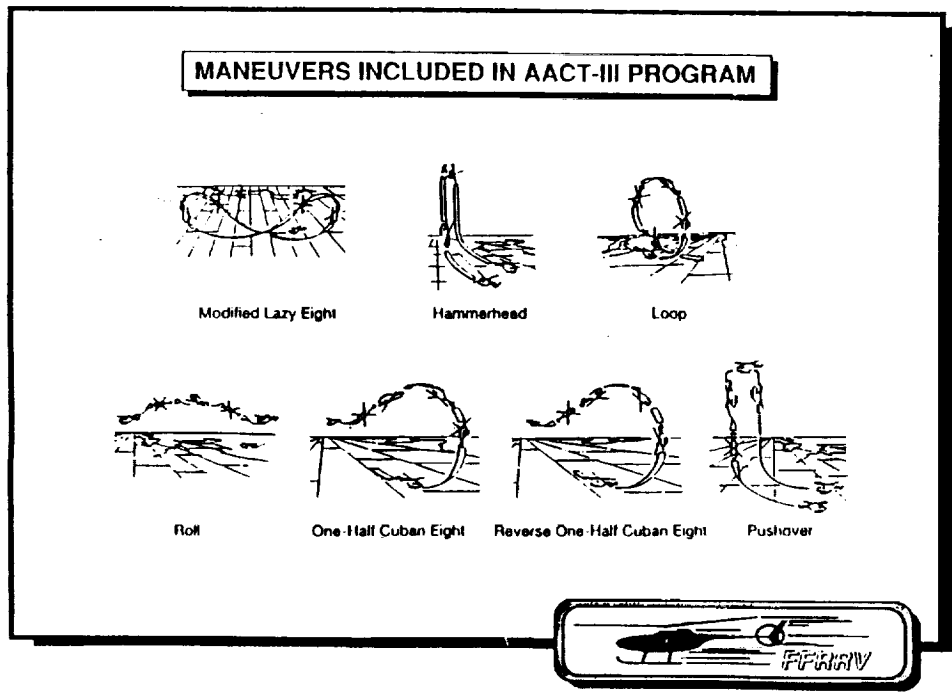

**SLIDE 6:** We want to look at aerodynamics in the "non-linear" world typical of air-to-air combat or nap-of-earth flying. This slide shows examples of maneuvering that characterize advanced combat rotorcraft. The researchers challenge is to quantify what makes a rotorcraft configuration more or less capable of such aggressive maneuvering.

SLIDE 7:

### OUTLINE OF PRESENTATION

- An Overview Of The Free Flight Rotorcraft Program
- Why This Program Is Looking At Fuzzy Logic Control
- Professor Sugeno's (Tokyo Institute of Technology) "Fuzzy Control of Unmanned Helicopters" Project
- Current Status



### TRADITIONAL APPROACH

Model The Aircraft → Build → A Stabilizer Of The System

#### Attributes Of This Approach

- Non-linear dynamics -> often linearized for simplicity
- Requires a detailed knowledge of the physical system
- Overall performance directly related to the models accuracy

#### Strategy

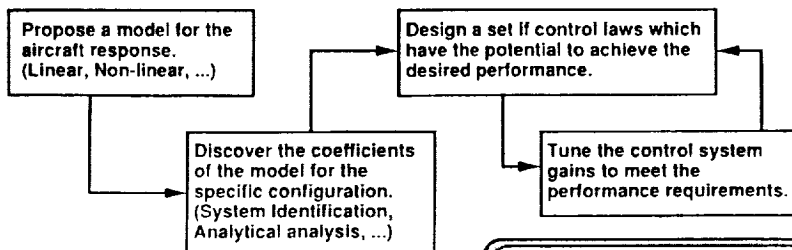

SLIDE 8: This is a "road map" to a traditional approach to developing a flight control system. These attributes are typical of model following control systems.



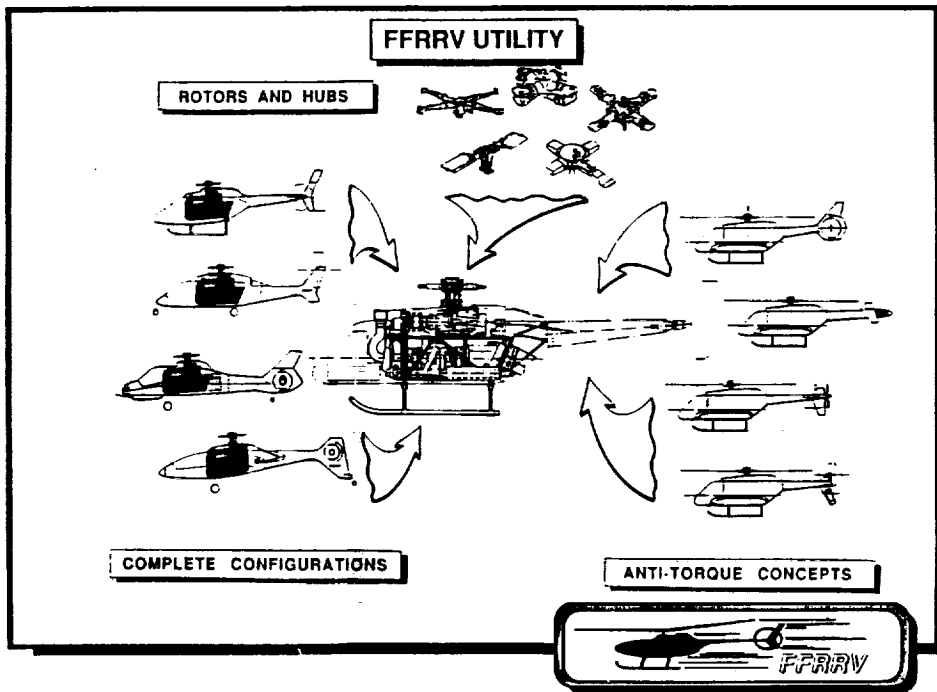

**SLIDE 9:** This slide shows how we intend to use FFRRV. These changes to the aircraft model affect the dynamical control system approach that a traditional control system approach requires. Some of these changes may require refining the models coefficients while other changes will force us to begin at the top, that of defining the mathematical model all over.

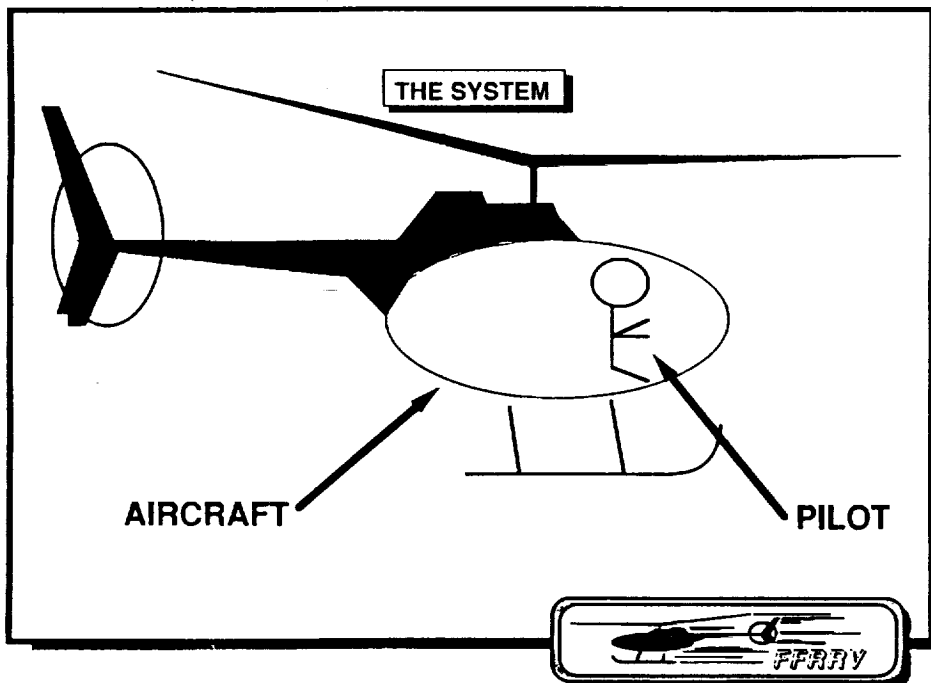

**SLIDE 10:** The system I am working with and trying to regulate has two portions: the aircraft and the pilot (where ever he/she resides). Instead of modeling the ever-changing aircraft I am modeling an adaptive pilot.

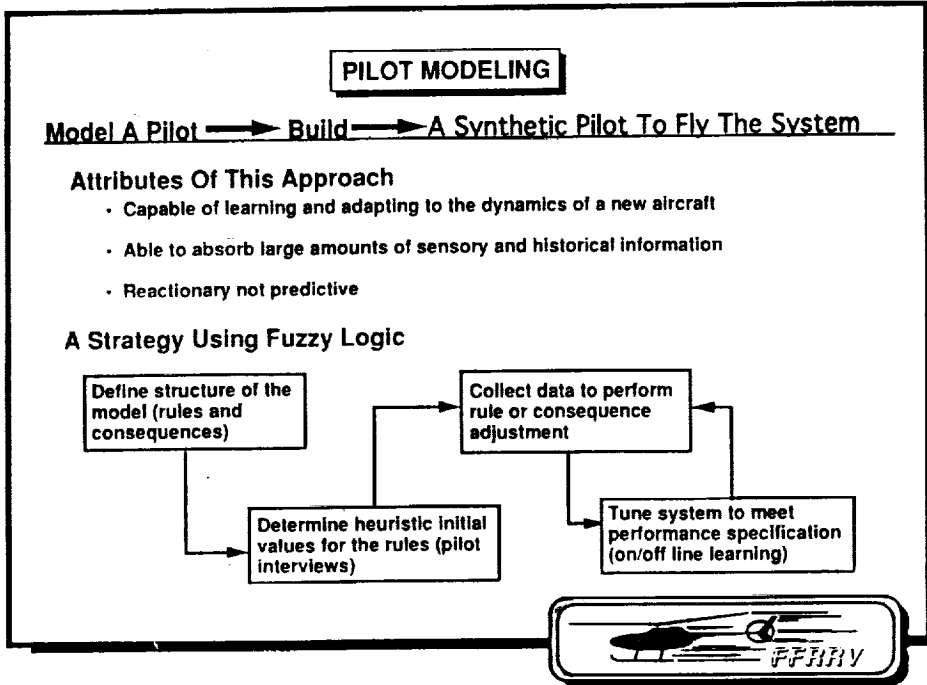

SLIDE 11: Good pilot modeling should incorporate these attributes. This strategy is the approach Professor Sugeno at Tokyo Institute of Technology has used to attack this problem.

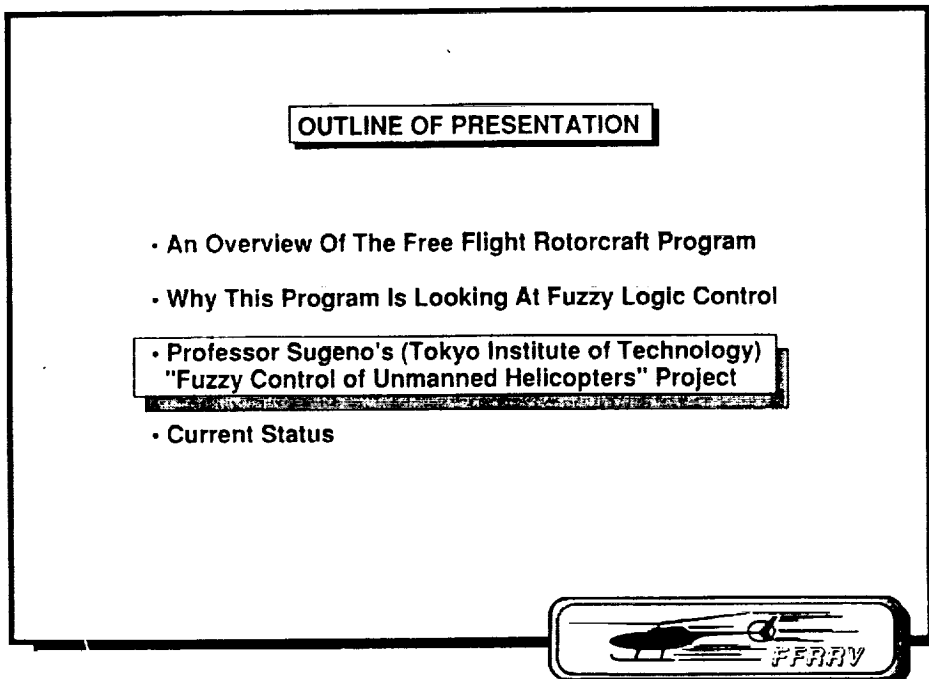

SLIDE 12:

## Unmanned Helicopter for Sea Rescue

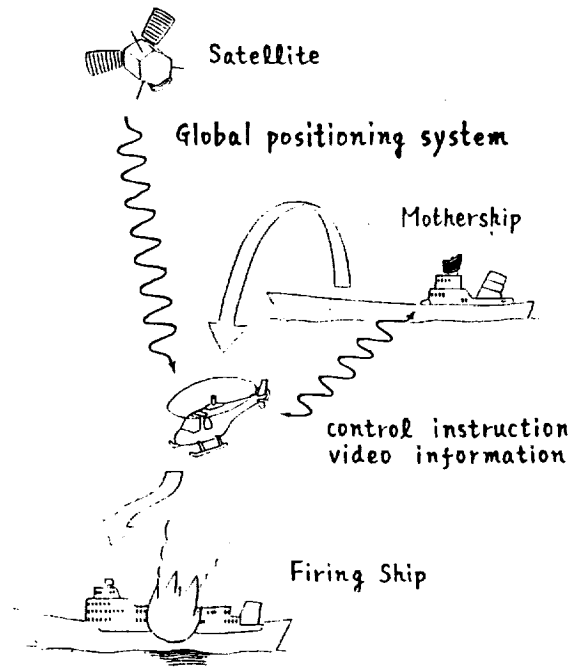

**SLIDE 13:** This mission is Professor Sugeno's carrot. To get to this point he is developing and demonstrating portions of the system using smaller prototyping projects.

## Remote Control of Helicopter by Oral Instructions

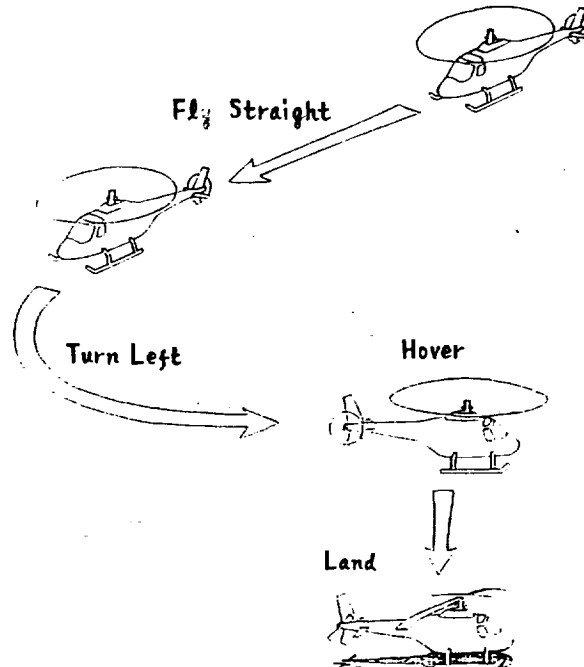

**SLIDE 14:** Professor Sugeno has had this kind of high level control of both a real-time non-linear helicopter simulator and a free flying industrial model helicopter. The oral instructions incorporated to date in his project are:

- Hover
- Takeoff
- Land
- Turn left/right (pedal turn)
- Fly left/right
- Fly forward/backward
- Climb
- Coordinated turn left/right

## Automatic Autorotation Entry

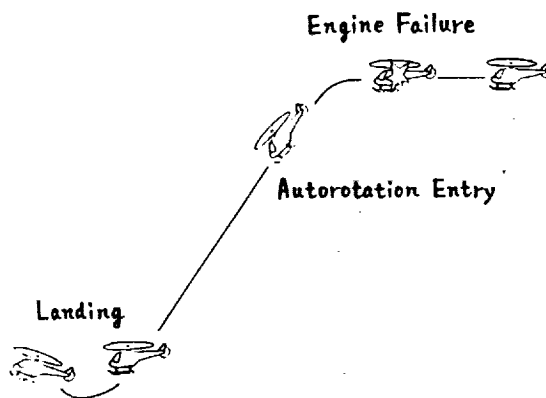

**SLIDE 15:** This project's intention is to maintain constant rotor speed during decent so the pilot can easily judge when to flare and land smoothly.

This maneuver is one of the first a student pilot learns. However, fowl weather and the complexity of finding a real place to land make the task much more challenging. This controller is aimed at reducing the pilots work load in such cases by allowing the pilot to focus on finding a suitable landing zone while requiring the controller to keep a known amount of energy stored in the rotor.

---

## Linguistic Rules

### Example For Hovering

- 1) If the body rolls, then control the lateral cyclic in reverse.
- 2) If the body pitches, then control the longitudinal cyclic in reverse.
- 3) If the nose turns, then control the tail rotor collective in reverse.
- 4) If the body moves sideways, then control the lateral cyclic in reverse.
- 5) If the body moves back and forth, then control the longitudinal cyclic in reverse.
- 6) If the body moves up or down, then control the main rotor collective in reverse.

**SLIDE 16:** The rule base for Professor Sugeno's controllers is based on linguistic statements like these. The power of such a fuzzy logic controller comes from firing all the rules in parallel. This strategy allows decomposing the problem into smaller more manageable blocks but does not loose the interdependencies and cross coupling required to operate such a coupled system as a helicopter.

# Hierarchical Modular System

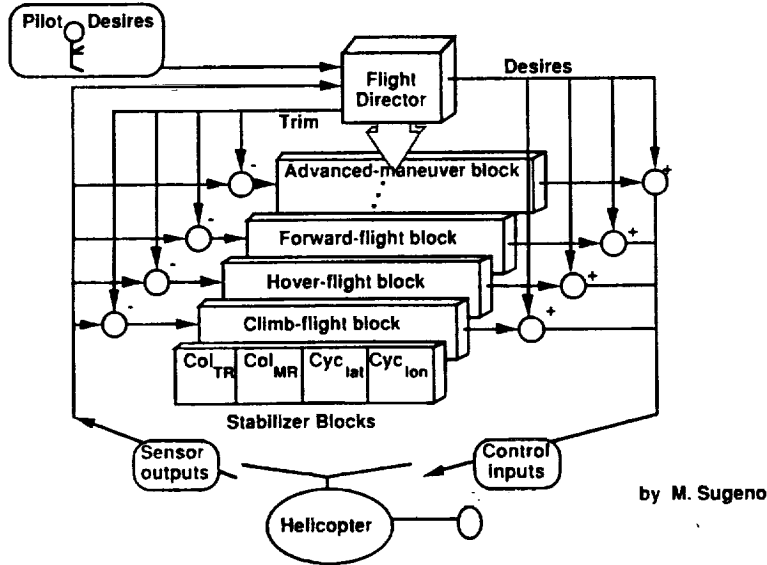

SLIDE 17: At first glance Professor Sugeno's controller appears like a simple gain scheduling controller. There are some significant differences: First, the lower level blocks are autonomous fuzzy logic controllers that can only perform their select mission. Secondly, the "gain scheduler" is not simply a mode switcher but is another fuzzy logic engine which blends the lower level blocks together to achieve a more abstract desire described by the pilot.

# Lower Level Modules

## Stabilizer Blocks

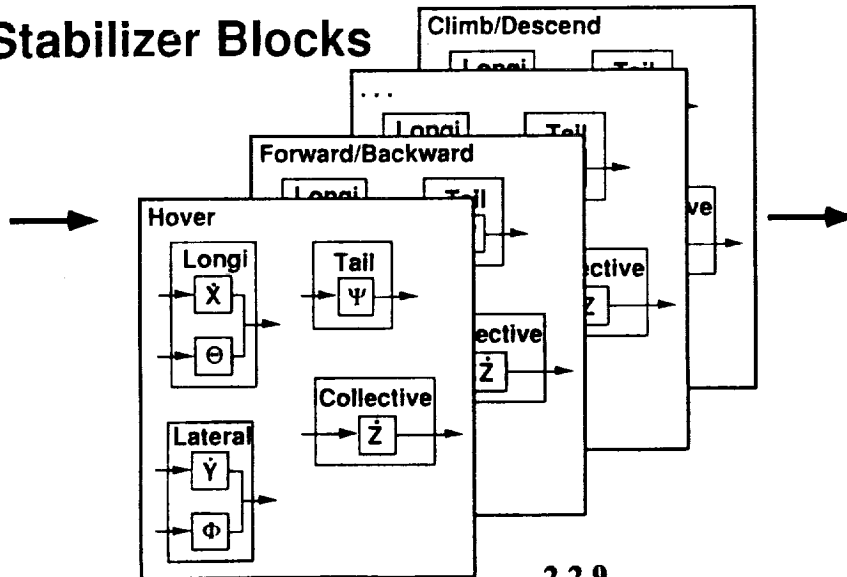

SLIDE 18: All the lower level stabilizer blocks have similar structure but each one is a unique multi-input/multi-output closed loop controller. The rule base and the fuzzy variable sets are different for each of these lower level blocks.

## OUTLINE OF PRESENTATION

- An Overview Of The Free Flight Rotorcraft Program
- Why This Program Is Looking At Fuzzy Logic Control
- Professor Sugeno's (Tokyo Institute of Technology) "Fuzzy Control of Unmanned Helicopters" Project

• **Current Status**



**SLIDE 19:** In addition to building up the research vehicle the Free Flight Project is currently prototyping various systems using commercial and industrial model helicopters. This prototyping includes: video check out, telemetry, sensor fusion including gps, and control strategies.

Tokyo Institute of Technology's work is ongoing and is currently focused on adding more flight capabilities to their industrial model. Some of these enhancements are: more aggressive flying, telemetry, gps.

## CONCLUDING REMARKS

- A control system using fuzzy logic to model a pilot can provide stability to a helicopter.
- Prototyping efforts to demonstrate this are ongoing here at LaRC and in Japan.
- The design and use of such a controller requires a new focus.



**SLIDE 20:** The third bullet is the key. To really understand why fuzzy controller are proving successful requires a new focus on the problem. These fuzzy controllers model pilot response, not aircraft dynamics.

# **Reconfigurable Control**

**Hopfield Network Investigation**

**Phil Chandler, Meir Pachter**

**Mark Mears, Bob Smith**

**WRIGHT LABORATORY  
FLIGHT CONTROL DIVISION**

# Hopfield Network Based Controller

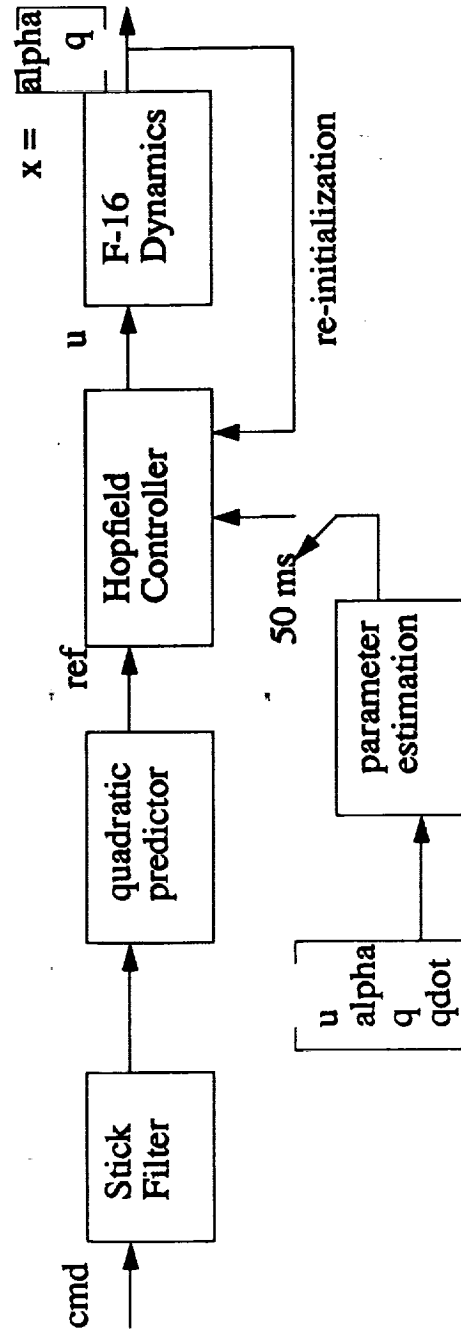

## Control Optimization

- linear dynamics

$$NV = C$$

$$V = [x_1, \dots, x_k, u_1, \dots, u_k]^T$$

- quadratic cost

$$V^T Q V + b^T V$$



# Algebraic Riccati Equation Based Controller

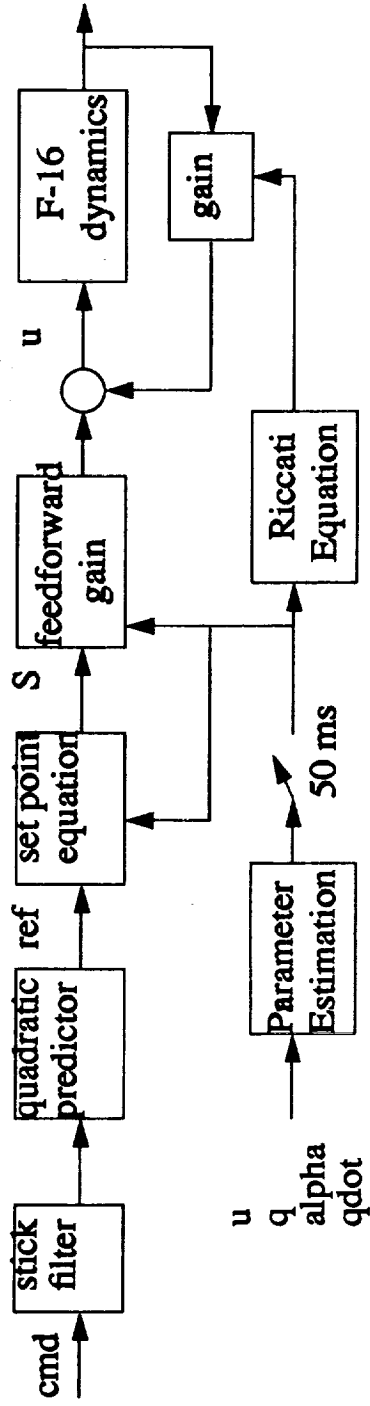

## Control Optimization

$$A^T P + P A - P B R^{-1} B^T P + Q = 0$$

$$\dot{s} = [A^T - P B R^{-1} B^T] s + Q_{ref}$$

## Estimation

$$Z = H\theta + v_1; M\theta = a + v_2$$

$$\hat{\theta} = \hat{\Theta}_{MV} + P_{MV} M^T (M P_{MV} M^T + R_2)^{-1} (a - M \hat{\Theta}_{MV})$$

## Penalty Method

### Direct Minimization

$$J(v) = \frac{1}{2} v^T Q v + v^T c + \frac{1}{2} \lambda (A v - b)^T (A v - b)$$

$$\frac{\partial J}{\partial v} = Q v + c + \lambda A^T (A v - b)$$

$$v = [Q + \lambda A^T A]^{-1} (\lambda A^T b - c)$$

### Hopfield Network (gradient descent)

$$J = \frac{1}{2} \sum_{k=1}^M [(C x_k - \text{ref})^T Q (C x_k - \text{ref}) + u_k^T R u_k + \lambda \|x_{k+1} - A x_k - B u_k\|^2]$$

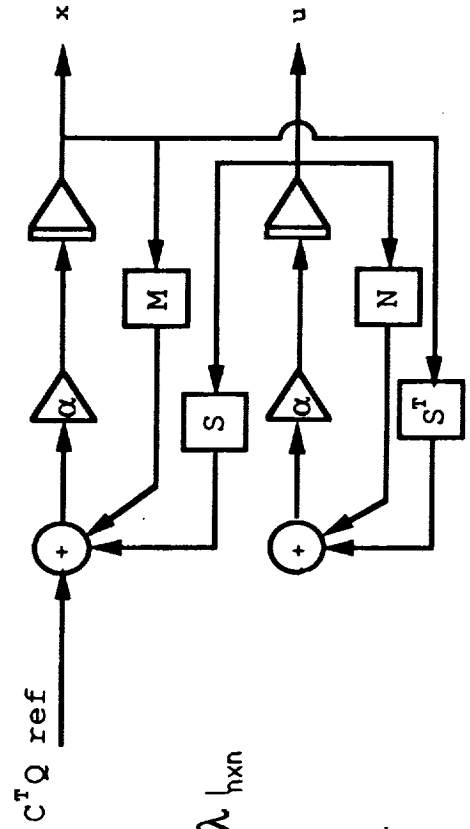

$$M = C^T Q C + \lambda A^T A + \lambda I_{h \times n}$$

$$N = R + \lambda B^T B$$

$$S = \lambda (A^T - I_{h \times n}) B$$

$\alpha$  == Gradient "step size"

# Lagrange Multiplier Approach

## Hopfield Network

$$J = \frac{1}{2} \sum_{k=1}^M [(Cx_k - \text{ref})^T Q (Cx_k - \text{ref}) + u_k^T Ru_k + \lambda^T (x_{k+1} - Ax_k - Bu_k)]$$

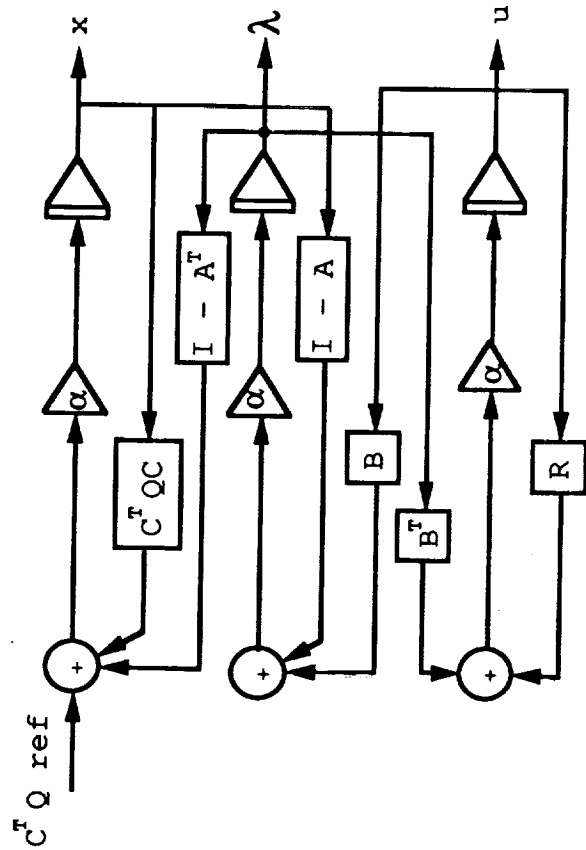

## Equivalent Direct Optimization

$$J = \frac{1}{2} v^T M v + v^T b + \lambda^T (A v - c)$$

$$\begin{bmatrix} v \\ \lambda \end{bmatrix} = \begin{bmatrix} M A^T \\ A \ 0 \end{bmatrix}^{-1} \begin{bmatrix} -b \\ c \end{bmatrix}$$

## **Equivalency**

1. Discrete-time dynamic problem tested
2. Discrete-time dynamic problem easily converted to equivalent static problem
3. Riccati is feedback form of Calculus of Variations optimization
4. Riccati eq. provides solution for dynamic problem
5. LaGrange multiplier approach provides solution to static optimization problem
6. Static problem = Dynamic problem = Riccati = LaGrange approach

## **So Why Hopfield Networks ?**

(on a convex linear quadratic problem)

1. Speed a la massive parallelism
2. Analog hardware implementation

# Plot of Riccati vs HNN

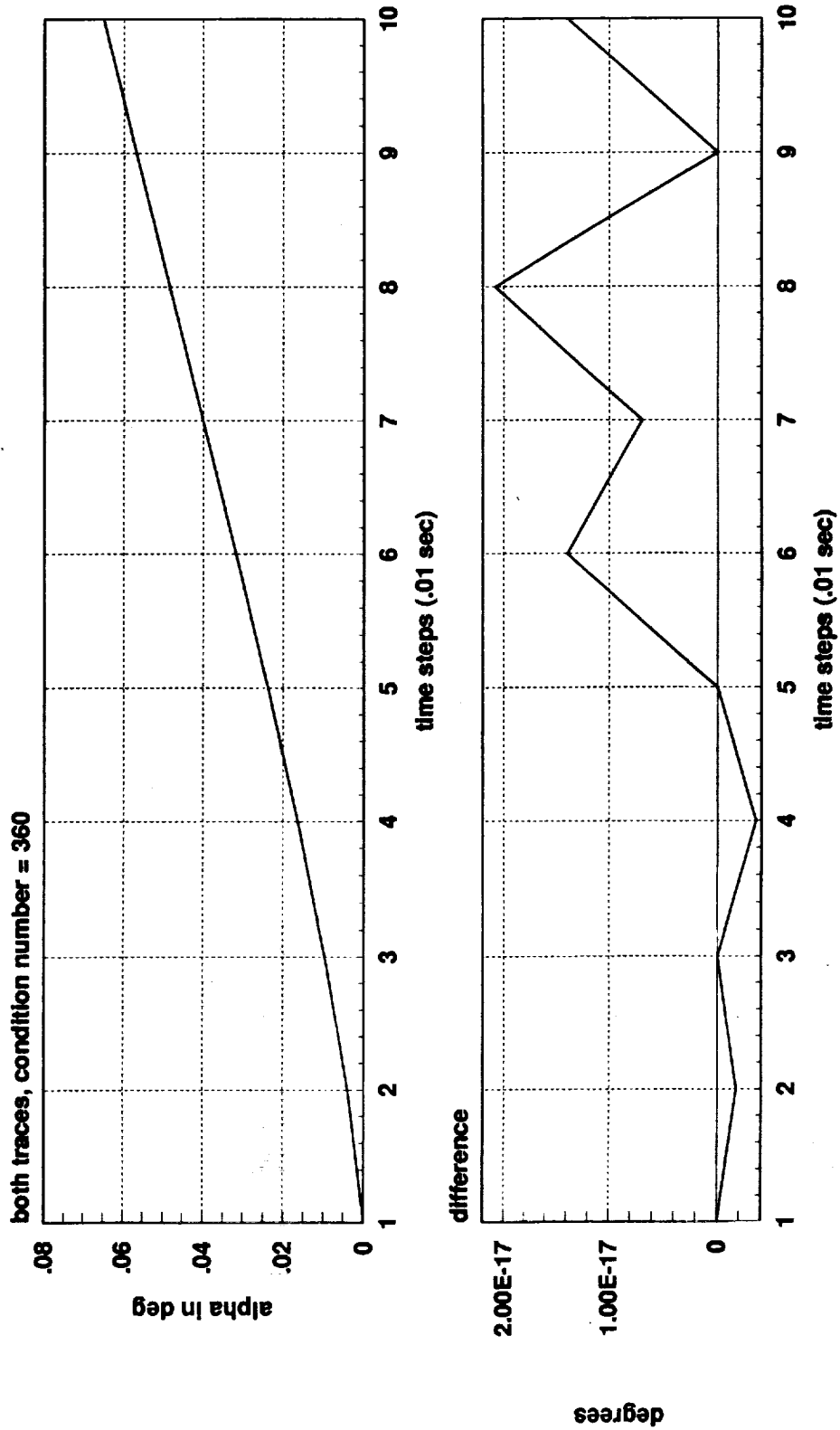

# Example Problem w/failure (HNN penalty)

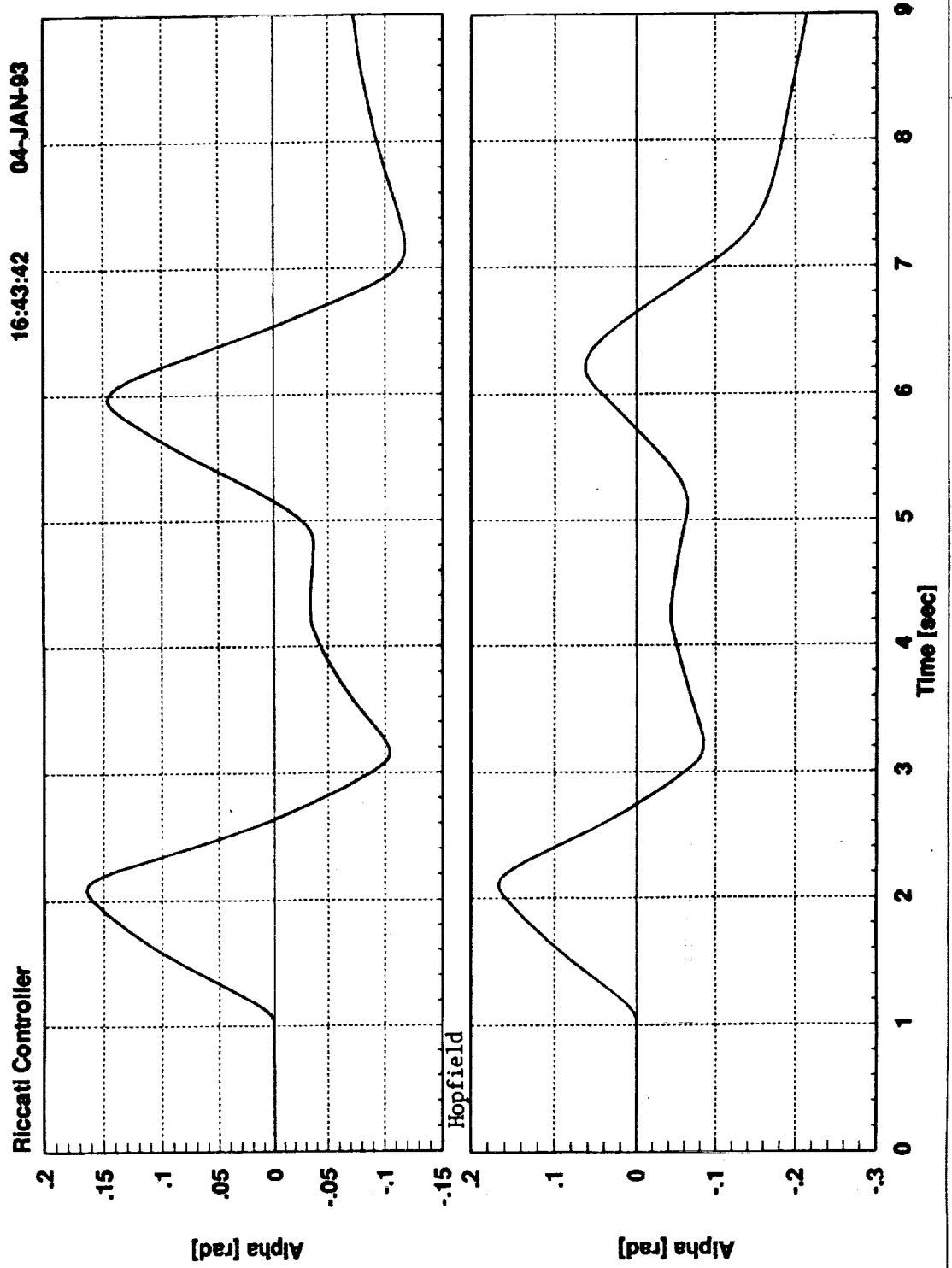

# Example Problem ID Performance

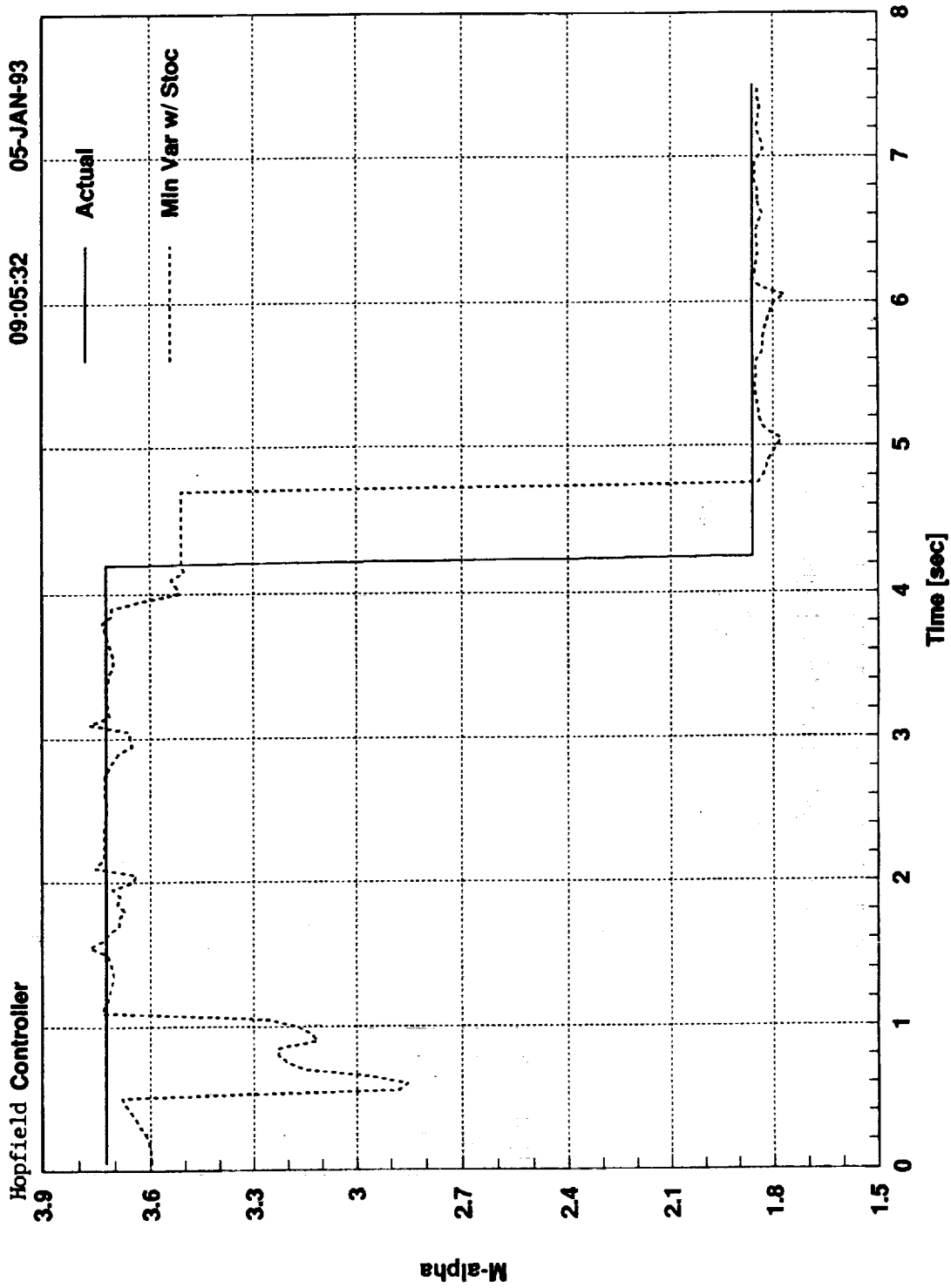

## What about Nonlinear Constraints?

(non convex, non quadratic)

1. Linearize  $\Rightarrow$  LQ

2. Dynamic inversion  $\Rightarrow$  linear  $\Rightarrow$  LQ

3. Nonlinear Optimization

How? : pseudo simulated annealing a la HNN

1) HNN locates minimum (local)

2) hill climbing for x steps

3) Goto 1) and repeat N times



## Summary

Hopfield Network equivalent to Riccati solution

Fast analog implementation possible if condition no. low enough, eg  $k=300$

$$\left| \frac{\Delta\theta}{\theta} \right| \leq \kappa \left| \frac{\Delta y}{y} \right|$$

have approx. 60 db signal/noise ratio, then will yield acceptable results

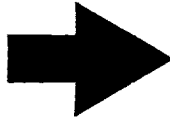

Hopfield Networks appear suited for nonlinear (adaptive) control

