

N94- 25675

74

## THE ENABLER: A CONCEPT FOR A LUNAR WORK VEHICLE

Georgia Institute of Technology  
School of Mechanical Engineering  
Atlanta, Georgia

Professor James W. Brazell  
Craig Campbell and Ken Kaser, Teaching Assistants

### Abstract

The Enabler is an earthbound prototype designed to model an actual lunar work vehicle and is able to perform many of the tasks that might be expected of a lunar work vehicle. The vehicle will be constructed entirely from parts made by students and from standard stock parts. The design utilizes only four distinct chassis pieces and sixteen moving parts. The Enabler has non-orthogonal articulating joints that give the vehicle a wide range of mobility and reduce the total number of parts. Composite wheels provide the primary suspension system for the vehicle.

### Introduction

In the future, NASA will place a manned space station on the moon. The inhabitants of the base will need a lunar work vehicle to aid in the construction of the space station. The vehicle must be capable of maneuvering over the rough lunar terrain and of lifting and moving payloads. The vehicle must also be able to operate tools such as drills and winches.

The Enabler was designed to show how an actual work vehicle might be designed. The design is simple and utilizes only four distinct chassis pieces and sixteen moving parts. The entire vehicle is made of stock parts or parts that can be made by undergraduate mechanical engineering students. Undergraduate students at Georgia Tech will begin construction of the full-scale prototype vehicle during Fall Quarter, 1993.

Unique non-orthogonal articulating joints provide steering and pitch control for the Enabler. The joints make it possible for the Enabler to maneuver over rough terrain similar to that found on the moon. Each joint is composed of only two moving pieces, not counting

motors and assembly hardware. This design eliminates the need for complex steering assemblies.

The Enabler has a boom structure that can lift and move a payload inside a large work envelope. A combination of non-orthogonal and rotating joints on the boom makes it possible to approach any point on the work envelope from more than one direction. A mechanical tool interface attached to the boom makes it possible for the Enabler to operate a wide range of tools.

Although the Enabler performs many of the functions that an actual lunar work vehicle would perform, it is designed for use under earthbound conditions.

### General Parameters

The proposed work vehicle has an overall length of 6 m and an overall height of 2 m (see Figure 1). It is driven by six wheels, each of which is powered by a 1/2 hp motor. The vehicle can attain a top speed of 12 km/hr and can climb an effective grade of 20% from a standing start. Each wheel and its corresponding drive assembly, motor, reducer, and battery, is completely detachable from the chassis. In the event that one wheel drive unit is damaged, the entire unit can be removed and quickly replaced.

The main chassis of the vehicle has two T-Sections, a center section, four chassis joint pieces, and mounting hardware. The T-Sections and center section provide the interface between the chassis of the vehicle and the wheels. The chassis joint pieces are the main structure of the vehicle. Two pieces are mounted between two of the T-Sections. A 15° angle at the joint where the two pieces meet allows for articulation and steering of the vehicle.

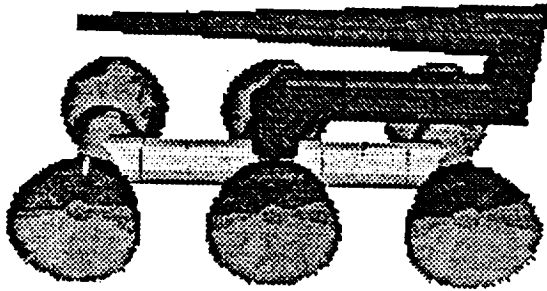

Fig. 1 Enabler overview

The vehicle has a six-piece boom structure with a tool interface mounted at the end of the boom. The boom and tool interface can lift a 50 N payload.

The vehicle can be operated through a Macintosh IICI either onboard or remotely.

### Wheels

The wheels are made of a resilient composite material and are conical in shape. The wheel design is based on a similar design used for a candidate lunar rover vehicle.<sup>1</sup> The design is also outlined in several patents by Ed Markow.<sup>3,4</sup>

The diameter of each wheel at the rim is 1.2 m and the wheels are 0.5 m wide, as shown in Figure 2. The wheel thickness varies from 3.4 mm at the rim to 2 mm in the section adjacent to the hub, and the hub section is reinforced to prevent deflection. The hub thickness is 7.6 mm. Each wheel will weigh roughly 89 N.

The wheel is made of structural fiberglass. The fiberglass has an inherent spring rate and damping coefficient that provides part of the suspension for the vehicle. The wheels work together with the articulation joints to provide the entire suspension system. As the wheel is loaded, it deflects and moves outward; the scuffing between the wheel and the surface provides an additional damping effect.

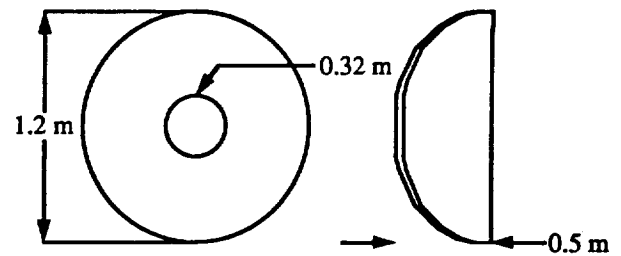

Fig. 2 Wheel

The spring rate for the wheel design was estimated by dividing the static load by the estimated static deflection. It was assumed that all the weight of the vehicle would be on two wheels in worst-case loading conditions. When all six wheels are in operation, the static deflection is estimated to be 5 cm.

The formula for the spring rate is

$$k = \frac{\text{force}}{\text{deflection}} \quad (1)$$

where the static force is 3340 N and the static deflection is 15 cm.

The spring rate for the wheel is intended to be 219 N/cm. This rate is varied during development by adding layers of fiberglass or slotting the wheel in low stress regions.

The angle that the centerline of the wheel makes with the ground (flat surface) affects the wheel's performance. For optimum power train efficiency the wheel should be angled down 15°. However, as the angle increases from 0°, the ratio of track width to vehicle width decreases and stability decreases. The angle was set at zero because it results in only a 3% power train inefficiency.

The fiberglass material of the wheel is not expected to provide enough traction by itself. Either metal cleats or a rubber tread will be added to improve the traction capabilities.

### Wheel Drives

Each wheel is driven by a DC motor, which is powered by one battery. The DC motor is coupled to a speed reducer, which in turn is coupled to a flexible coupling. The coupling mounts to the wheel and negates the effect of any bearing eccentricities.

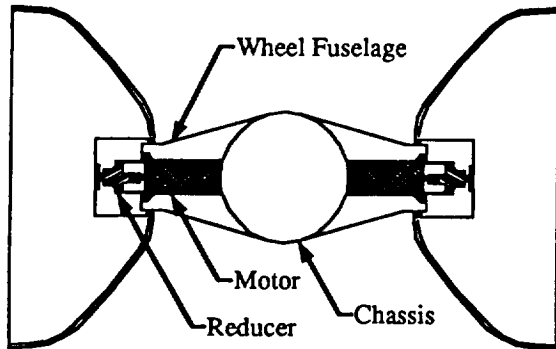

Fig. 3 Wheel drive assembly

All of the components of the wheel/wheel drive assembly—with the exception of the battery—attach to a wheel fuselage. The wheel mounts to the outside of the fuselage via a large ring bearing, while the other components mount to the inside of the wheel fuselage, as shown in Figure 3.

Each wheel fuselage is attached to the chassis of the vehicle by a band clamp. The clamp holds two flanges together, one at the end of the wheel fuselage and the other at the end of the T-Section of the chassis. The entire wheel/wheel drive assembly can be removed from the Enabler by simply removing the band clamp. This makes quick removal of a malfunctioning unit possible. Once a malfunctioning unit is removed, the Enabler can either operate without the unit, or the malfunctioning unit can readily be replaced if a properly functioning one is available.

### Chassis/Articulation

The two non-orthogonal chassis articulation joints provide steering and pitch control for the vehicle. These two identical joints are located between the T-sections and the center piece. The two main pieces that comprise each articulation joint have a  $15^\circ$  angle at the ends where

the two pieces connect. With a total of four pieces in the two joint assemblies, the chassis can rotate through a total angle of  $60^\circ$  for steering or pitching.

The non-orthogonal joints enable the vehicle to operate on rough terrain like that found on the moon. The ability to pitch the front and rear axles of the vehicle enables the vehicle to climb over objects through a series of joint rotations. Freewheeling the articulation joints makes it possible for each of the three axles to operate in different planes and still have all six wheels in contact with the ground.

Simple angular relationships exist between the rotation of each joint component for steering and pitching. To achieve the desired turn angle, the joint components must rotate at an angle of three times the turn angle relative to each other. For example, the maximum turn of  $30^\circ$  in one direction is attained by rotating the component of the joint closest to the end of the vehicle by an angle of six times the climb angle while keeping the other component stationary. A pitch angle of  $30^\circ$  is accomplished by rotating the end joint component  $180^\circ$  without moving the inner joint component. Pitch and turn orientations are illustrated in Figures 4 and 5, respectively.

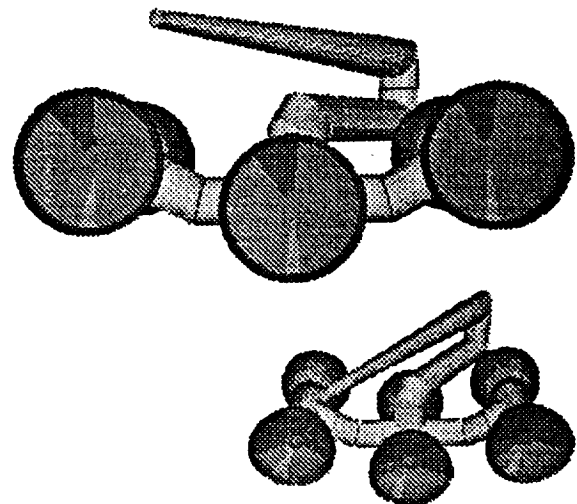

Fig. 4 Pitch orientations

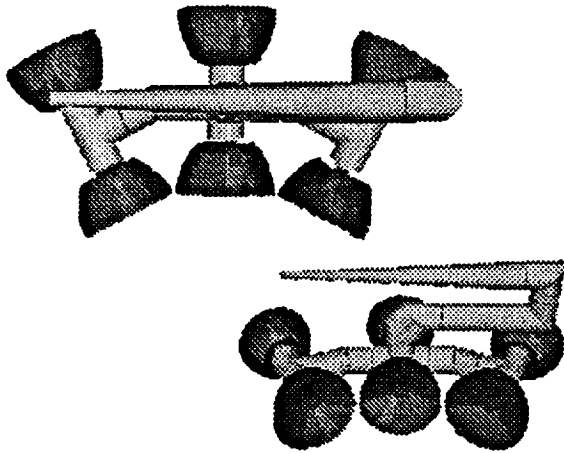

Fig. 5 Steering orientations

A 0.56 kilowatt, 24-volt permanent magnet DC motor with an output speed of 1750 RPM drives each joint. The use of a gearless speed reducer and pinion-gear assembly lowers the final rotational speed of each joint to a maximum of 27 RPM, so each joint can complete one rotation in 2.2 seconds. Since the top speed of the vehicle is only 12 kilometers per hour, this rotational speed is adequate for control of the vehicle. A fail-safe electronically controlled brake stops and holds the joint at the desired angle. It is not always necessary to power each joint; each drive system allows its joint to freewheel when power is not required.

### Boom

The boom gives the Enabler the ability to carry out several functions. It allows the Enabler to lift objects, push them, or pull them throughout a large range of motion; it also lets the operator manipulate the vehicle's tools.

The boom is mounted between the Enabler's central wheels and can extend 9 m from its base. It is capable of reaching any point within a hemisphere above the Enabler, and it can reach below the plane of the vehicle's wheels. The boom is not limited to one approach configuration; it can approach a point within its sphere of

operation from many angles. This freedom of approach configuration allows it to reach around obstacles. The boom derives its versatility by utilizing four joints. One joint, at the boom's base, allows the whole assembly to rotate 360° (Plane 1). Another joint, at an angle of 45° to Plane 1 allows the upper boom to rotate in a new plane (Plane 2). The next joint allows the boom tip to move in a plane 45° to Plane 2 (Plane 3). The final joint allows movement perpendicular to Plane 3. Therefore, the boom can place its tip at any point in any plane within its operational envelope (see Figure 6).

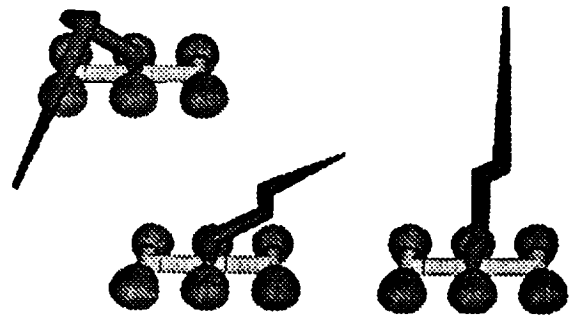

Fig. 6 Various boom orientations

The Enabler uses the boom to manipulate objects up to 50 N. A 24-volt motor moves each joint using a reduction gear box. Each joint rotates at 6° per second, thus completing one revolution in one minute.

The boom has a fail-safe tool interface that releases a tool only when inserted into the tool rack. The inventory of possible tools includes drills, winches, clamps, and shovels. The boom's ability to attain many approach angles enables it to drill holes at any desired angle.

### Controls

The Enabler is equipped with a comprehensive system through which the operator may manipulate and monitor the vehicle. The operator can manipulate the vehicle's speed, direction, approach configuration, and boom orientation with minimal input. The operator can also monitor the status of the vehicle as each command is carried out.

A Macintosh IIfx-based console acts as the interface between man and machine; it also serves as the CPU for the vehicle. The operator enters commands and the IIfx translates them into a digital signal. This signal is then sent through a fiber optic network to the various motor control devices. The fiber optic network eliminates signal disturbances caused by EMI and RF interference.

Smart cards are located in the motor control devices (see Figure 7). Each smart card intercepts the signal designated for its specific motor and translates the signal into an analog format. The analog signal drives the motor. The smart cards share some of the computational responsibilities with the CPU in that they monitor the motor's conditions through feedback sensors located in the drive units of each motor and compute the necessary adjustments.

Monitoring devices located throughout the vehicle send global feedback to the CPU. The feedback includes vehicle orientation from gyroscopes, chassis loading, use of strategically placed strain gauges, and boom and articulation joint orientations, using the speed and position sensors within the drive units.

The CPU interprets the global feedback and adjusts all outputs accordingly. For example, the CPU alters the orientation of the joints if the gyroscope indicates that the vehicle is unstable. The CPU signals the operator if there is a system problem such as a joint not being able to attain its indicated position or a wheel operating at an incorrect speed.

The CPU's ultimate function is to determine a position and speed for each motor individually in order to fulfill the operator's desires. For example, the CPU determines the appropriate articulation joint position as well as individual wheel speeds when the operator designates a turning angle.

The control system is reliable due to the simplicity of its design. It is easy to use because the CPU automatically executes the controller's commands. The system does not respond to unsafe commands and it automatically protects the Enabler from any dangerous situations that may arise. The system is fast because it divides control responsibilities.

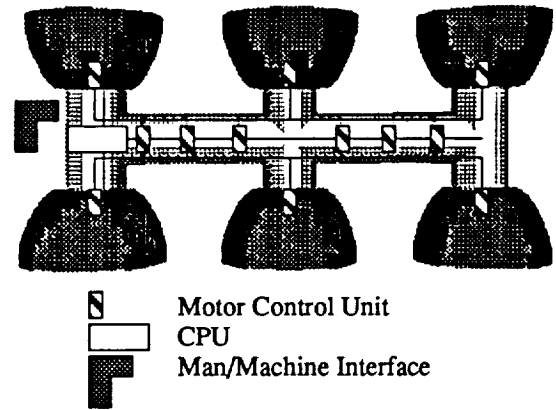

Fig. 7 Chassis controls schematic

### Conclusion

The Enabler has many of the features that an actual lunar work vehicle would have. The simple design cuts down on the total number of parts and the number of dissimilar parts. Ease of construction and good serviceability are desirable qualities for any mechanical design; they are essential qualities for a machine operating in a lunar environment where resources for construction and repair are limited. The Enabler can maneuver over rough terrain similar to that found on the moon. A highly maneuverable boom structure can lift and move a payload around a large work envelope. The unique joint design on the boom structure allows the boom to approach any point on the work envelope from many different directions. A mechanical tool interface enables the vehicle to use a wide variety of tools.

The Enabler serves as a proof-of-concept vehicle; it is not capable of actual lunar use. There are several problems with the operation of a lunar vehicle that are not addressed by the Enabler. The atmospheric conditions on the moon introduce heat transfer problems for several of the vehicle's systems. If the actual lunar vehicle uses electric motors like the Enabler, it will have to have a heat sink to provide a cooling system for the electric motors. Cooling the electronic components, especially the CPU, is another problem not addressed by the Enabler.

These are just a few of the many problems that still need to be addressed in designing an actual lunar vehicle.

However, the Enabler provides a solution to many of the questions that need to be answered in designing an actual lunar vehicle.

The Enabler was designed by senior Mechanical Engineering students at the Georgia Institute of Technology. The project was divided into six groups, each of whom was responsible for one section of the vehicle. The design decisions of the class are presented in this paper. The vehicle is under further development, and construction of the full-scale prototype will begin in the Fall of 1992. The completed vehicle will be exhibited at several professional exhibitions including the NASA/USRA Summer Conference in June, 1993.

#### **Acknowledgments**

Co-authors are James A. Austin, Clark Beard, Glenn Ceniza, Thomas Hamby, Anne Robinson, and Dana Wooters. We would also like to acknowledge the assistance of Jim Brazell, instructor for the Senior Mechanical Engineering Design project; Lewis Dorrity, instructor for Textile and Fiber Engineering Design; Jeff Donnel, Writing Coordinator for the School of Mechanical Engineering; and Craig Campbell and Ken Kaser, Teaching Assistants, for their assistance in putting together this paper. We would also like to acknowledge the School of Mechanical Engineering at Georgia Tech, NASA, and Universities Space Research Association for sponsoring this design program. The initial design of the Enabler was proposed by 40 senior Mechanical Engineering students at Georgia Tech in the Fall of 1991. The design and construction of Enabler is an ongoing process that will be finalized by Mechanical and Textile Engineering students during the 1992-1993 academic year.

#### **References**

1. "Design and Fabrication of Wheel for a Lunar Surface Vehicle." Detailed technical report. Grumman Aerospace Corporation, June, 1970. N70-31989 (NASA-CR-102755).
2. "Grumman Proposal for Lunar Roving Vehicle in Response to Request for Proposal IL-LRV-1."

Grumman Aerospace Corporation, 69-78 NAS, Aug., 1969.

3. Markow, Edward G, "Convolutd Cone Wheel," United States Patent Department, Patent Number 4705087, Nov., 1987.
4. Markow, Edward G. "Elastic Conoid Shaped Wheel," United States Patent Department, Patent Number 3698461, Oct., 1972.
5. Markow, Edward G. Phone conversation on Dec. 9, 1991.