

FIRST LUNAR OUTPOST

University of Puerto Rico
School of Architecture
Rio Piedras, Puerto Rico

Professor Aureo F. Andino, A.I.A.

Daniel Silva, Teaching Assistant

Nelson Ortiz, Model Consultant

Omar Alvarez, Julio A. Colón, Myrelle Colón, Alicia Diaz, Xochiquetzal Y. Escobar,

Alberto Garcia, Isabel C. González, Edwin Hill, Carlos Jiménez, Isaac Laboy,

Carlos G. Ramos, José A. Solis, Pablo R. Tirado, Frances Villarine

Abstract

Design and research efforts at the University of Puerto Rico have focused on the evaluation and refinement of the Habitability Criteria for prolonged human permanence in space during the last four years. Living quarters for a Mars mission and a third generation lunar base concept were proposed. This academic year, 1991-92, work on further refinement of the habitability criteria and design of partial gravity furniture was carried on.

During the first semester, design alternatives for furniture necessary in a habitat design optimized for lunar and Martian environments were developed. Designs are based on recent research data from lunar and Mars gravity simulations, and current NASA standards. Artifacts will be submitted to NASA architects to be tested in KC-135 flights.¹ Test findings will be submitted for incorporation in future updates to NASA habitat design standards.

Second semester work was aimed at integrating these findings into the First Lunar Outpost (FLO), a mission scenario currently being considered by NASA. The mission consists of a manned return to the moon by crews of four astronauts for periods of 45 days. The major hardware components of the mission are: (1) a Crew Module for the delivery of the crew and their supplies and (2) the Habitat Module, which will arrive on the Moon unmanned. Our design efforts concentrated on this

Habitat Module and on application of habitability criteria. Different geometries for the pressure vessel and their impact on the interior architecture were studied. Upon the selection of a geometry, a more detailed analysis of the interior design was performed, taking into consideration the reduced gravity, and the protection against radiation, micrometeorites, and the extreme temperature variation.

A proposal for a FLO was submitted by the students, consisting essentially of a 24-foot (7.3 m.) by 35-foot (10.67 m) high vertical cylinder with work areas, crew quarters, galley, wardroom, leisure facilities, health maintenance, waste management, EVA operations facilities, and safe havens.

Introduction

The First Lunar Outpost (FLO) is a mission scenario currently being considered by NASA. The mission consists of a manned return to the moon by crews of four in periods of 45 days (lunar day, night, day). The major components of the mission are: (1) the Habitat Module and (2) the Crew Module. The two modules are to be delivered by common lander elements, with the exception that the Crew Module has an ascent stage. The Habitat Module will arrive on the Moon unmanned and will remain on the lander. The Crew Module will deliver crew and supplies, landing approximately 1 km from the habitat.

Design efforts concentrated on the design of the Habitat Module and on the application of the habitability criteria. Three different geometries suitable for the

¹The KC-135 is a specially modified jet transport that flies a parabolic arc to produce short periods of less than one g acceleration force.

pressure vessel and their impact on the interior architecture were studied. These geometries were the cylinder, the sphere, and the cone. Precedents in the use of these geometries in manned space missions were studied before undertaking a preliminary habitat design for each one by different student groups. The vertical cylinder was chosen from these preliminary designs. Upon this selection, a more detailed analysis of the interior design was performed, taking into consideration the reduced gravity, and protection against radiation, micrometeorites, and the extreme temperature variation.

A proposal for an FLO was submitted by the students, consisting of 24-feet (7.3. m.) by 35-feet (10.67 m) high vertical cylinder with working areas, crew quarters, galley, wardroom, leisure facilities, health maintenance facility, waste management, EVA operation facilities, and safe havens.

Habitability Concept Definition

Three previous habitability studies developed by the students arrived at a concept definition which could be summarized as follows:

"Habitability is that state of equilibrium which results from the interaction between components of the Individual-Architecture-Mission Complex which allows a person to sustain psychological homeostasis, adequate performance, and acceptable social relationships."²

A diagram that presents the concept visually was developed to communicate the interdependence of the three parts of the complex. The individual's stress due to isolation, interpersonal stress due to confinement, and impersonal stress induced by a totally artificial or alien environment may cause a person to suffer psychological problems, which may impair the fulfillment of the mission or even the individual's motivation for survival in such an environment. The mission, together with the individual's values can provide the proper motivation and driving force for striving to accomplish expected goals and objectives as understood by the individual. But since psychology is shaped by built environment, it is the architecture of the environment that holds the key to factors that lead to quality of life, beyond the level of mere survival in a hostile environment. Sights, motions, and sounds, as well as careful consideration of all sensory stimuli will have to be envisioned and provided for before

we can be fully capable of designing the appropriate environment for human inhabitants in extraterrestrial space.

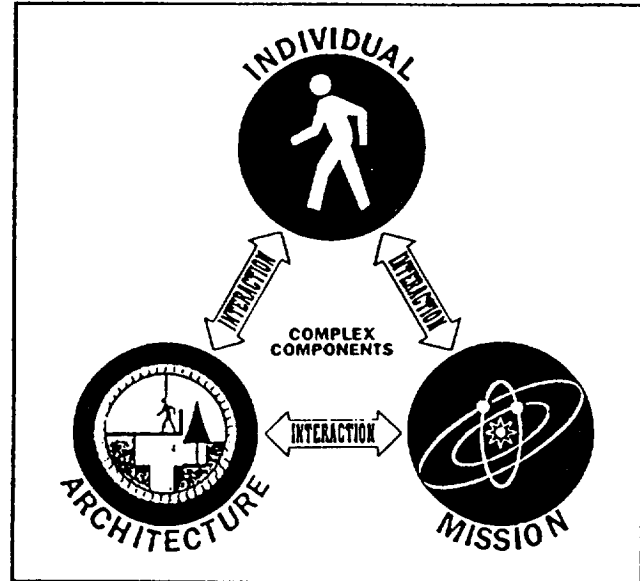

Fig. 1 Habitability concept diagram

Sights

Photobiological systems are particularly adapted to wavelengths somewhere between the 400 and 70 nm, the portion of the spectrum called "visible." In extraterrestrial space, intensity of contrast between the lighted and the shaded are extreme, since there is no atmospheric diffusion, refraction, or optical filtering phenomena. Color and depth perception will be perceived as a new experience.

Sounds

As we know, sounds travel in pressure waves and through a medium like air or water. These are called fluid-borne vibrations, which are medium composition and density dependent. Extraterrestrial atmospheres created for human habitation must, to some extent, reproduce Earth's atmosphere, to make sound transmission possible, and even be able to reproduce the quality of sounds, which are related to performing arts to be perceived.

FLO (Habitation Module)

- 6.1 EVA support area
 - 6.1.1 Airlock/Hyperbaric chamber
 - 6.1.2 Donning/Doffing stand
 - 6.1.3 Suit storage
 - 6.1.4 Suit maintenance
- 6.2 Stowage
- 6.3 Wardroom
- 6.4 Galley
- 6.5 Crew quarters
- 6.6 Medical facility
- 6.7 Exercise
- 6.8 Personal hygiene
- 6.9 Body waste management
- 6.10 Laundry facility
- 6.11 Trash management facility
- 6.12 Operations area
 - 6.12.1 Workstations
- 6.13 ECLSS

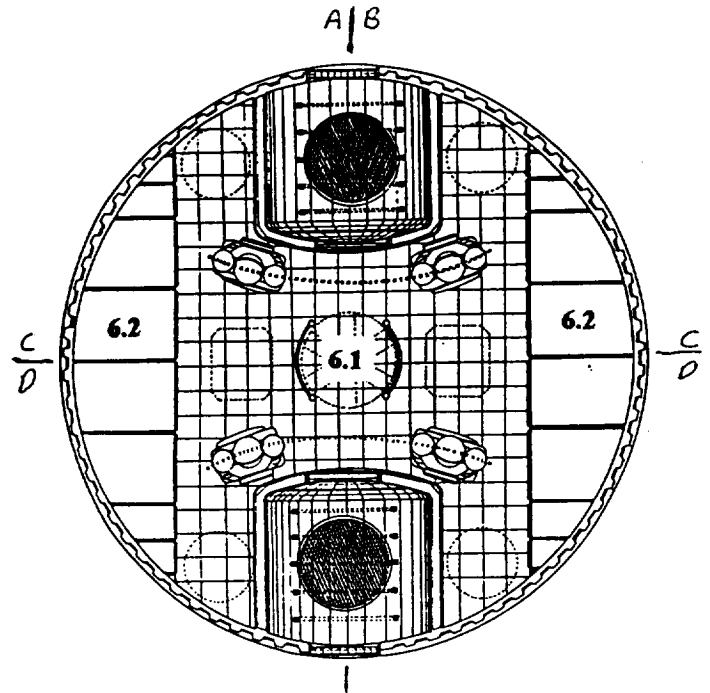

Fig. 6.1 First Level

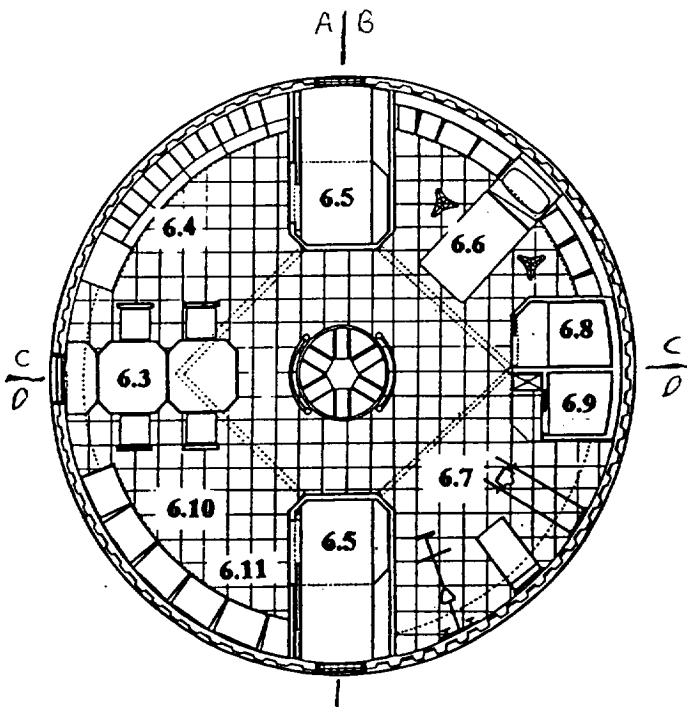

Fig. 6.2 Second Level

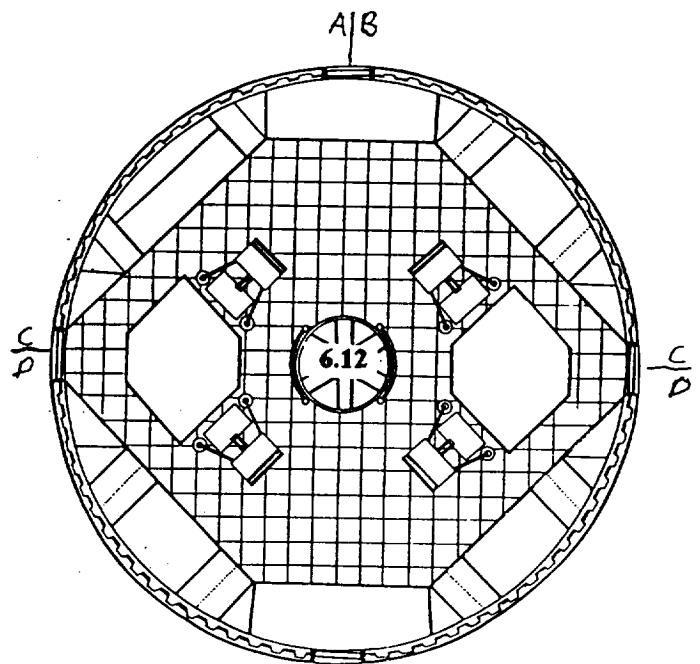

Fig. 6.3 Third Level

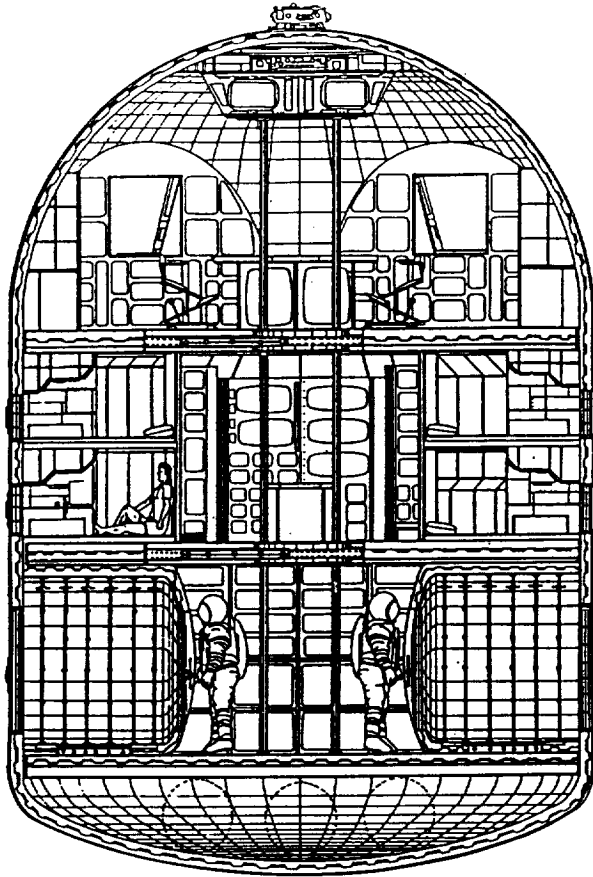

Fig. 6.4 Section A-A

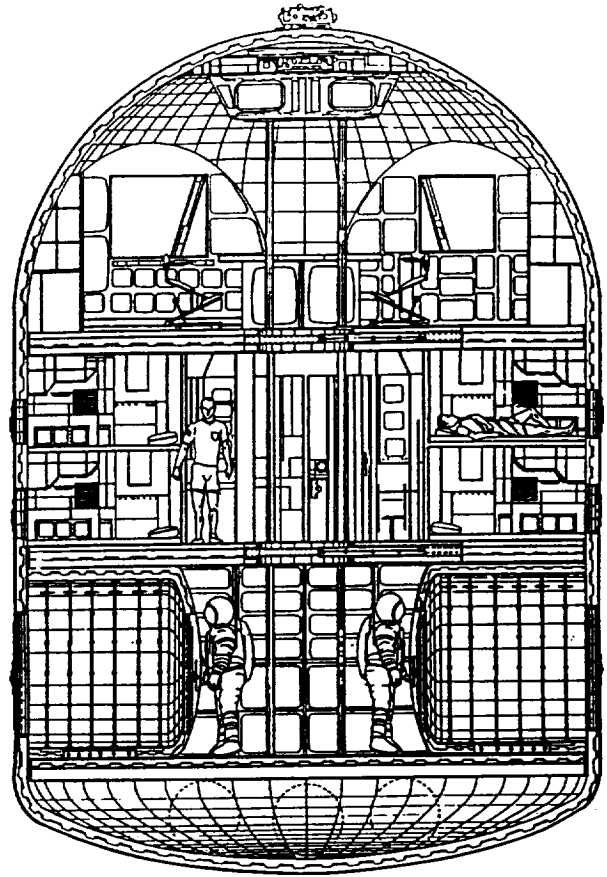

Fig. 6.5 Section B-B

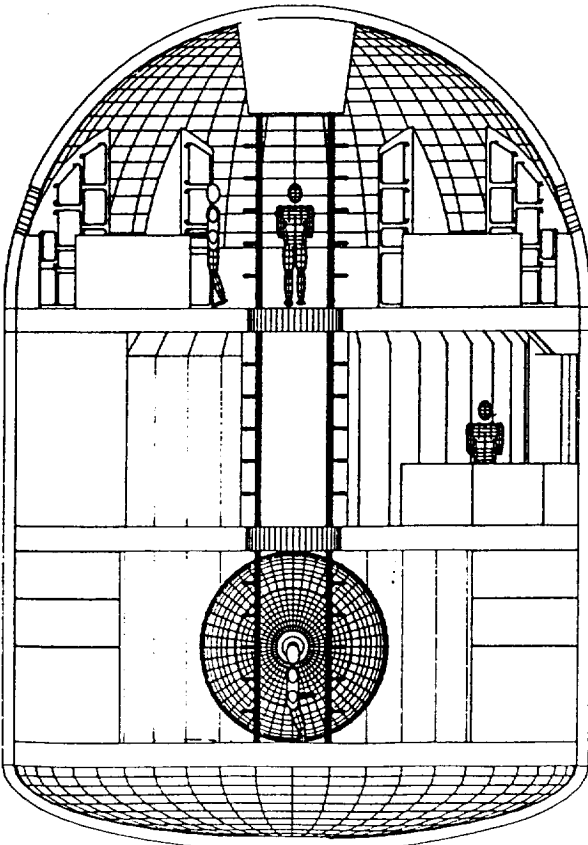

Fig. 6.6 Section C-C

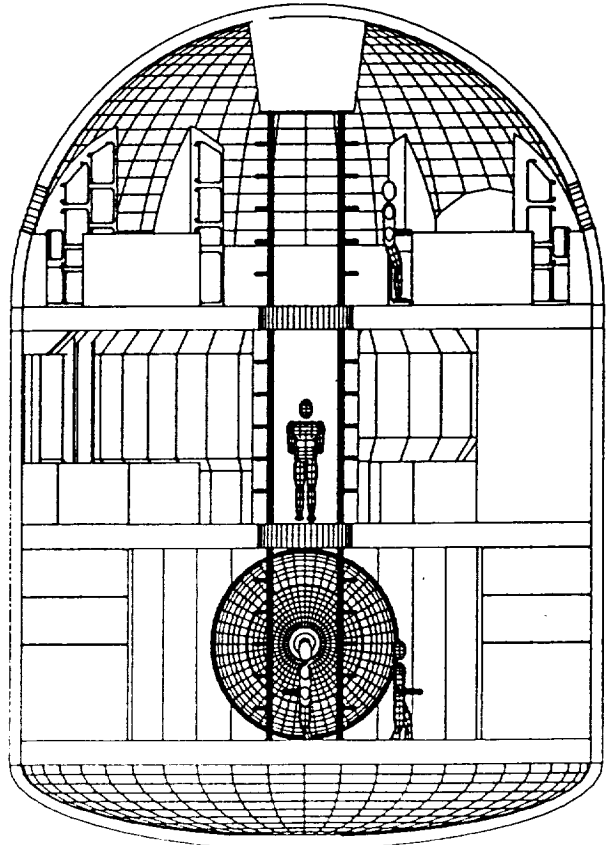

Fig. 6.7 Section D-D

Smells

Sight, hearing, and touch have been well-studied, but the sense of smell is not as easy to study in a quantitative manner. Nevertheless, smells must be taken into account when designing areas like laboratories or waste management facilities to control the propagation of annoying smells.

Motions

Vertigo and dizziness are a result of the malfunction of inner ear components like the vestibule and the semicircular canals. Reduced gravity environments will affect such sensors and will require upper body control, in addition to the usual bipedal erect balance which *Homo Sapiens* has evolved through millions of years. In a reduced gravity environment, a period of acclimatization to reduce muscular impulses, as well as to slower and softer movements, is required.

Even if these environmental factors are taken into account, we have identified seven problems which will arise from living in such alien conditions. These are:

Upset equilibrium. Reduced weight has a disturbing effect in the vestibular part of the inner ear, upsetting equilibrium. This can alter perception and accentuate psychological problems mentioned earlier. Its effects can be transitory or permanent, as was the case with early astronauts and cosmonauts.

Diminished stimulation. Reduced gravity may cause a reduction of the tone and threshold of the central nervous system. Brain activity may tend to diminish, possibly triggering apathy and fantasy.

The solipsism syndrome. Common sense holds that it is inherently ridiculous to think that the only reality is that which is perceived by the observer. But with the advent of access to extraterrestrial space, this academic oddity has become a real psychological danger. The absence of stimuli in the regular, ordered terrestrial environment can easily persuade a person that the real world begins and ends at the limit of the individual's sphere of perception.

Loss of identity. Increasingly long communication intervals reinforce the solipsism syndrome by straining more the link with reality. Even at a quite neighborly

distance, such as the Moon, communication will have time lags significant enough to disjoint a conversation, to lose the sense of connectedness, and to chop off interchange into a series of separate one-way messages.

Fear. Existence in a hostile environment kept at bay by a fragile life support system can induce anxiety and fear. This is especially critical during periods of low activity, which precede the short bursts of extreme activity under stress when major operations are to take place. Stress should be directed toward mission goal fulfillment to prevent phobias from getting out of control and causing critical conflicts to arise. Special procedures and therapy have to be provided in such cases.

Claustrophobia. The fear of enclosed places is a disqualifying tendency for anyone who is interested in pursuing life in extraterrestrial space. Testing will reveal such tendencies, but severe experiences in extraterrestrial space may induce it. Preventive and therapeutic measures have to be provided for inhabitants on conditions that would emulate artificially sensation of interior and exterior spaces.

Sexual frustration. The withdrawal of normal sexual outlets for prolonged periods naturally invites historical comparisons. The importance of the problem depends largely on the sexual drive of each individual, the key being the inevitable sublimation of directing such energy and drives toward a full programmed schedule of work to attain the goals and objectives of the mission.

Natural selection gave humans a specific body construction. Muscles and bones proved support to fragile organs. This creates problems when humans dwell beyond the frontiers of the terrestrial environment. In order to be productive, humans require a level of comfort as a required necessity for habitation beyond Earth.

Lifestyle Analysis

One important aspect of FLO operation is the crew. Living conditions must not be limited to the level of mere survival, but there must also be quality and style, promoting personal fulfillment and adequate performance. Work, rest, and leisure must be balanced, so that maximum advantage could be taken for productive

work without sacrificing maintenance functions or time for recreation, which is necessary to maintain high morale.

There is the possibility that a new group of four astronauts will come to the FLO every forty-five days, depending on the availability of the lunar transportation system, to replace the previous group. They will land on a site approximately one kilometer away from it, and will transfer their supplies, using a rover type of transport during the first two days, alternating the moon-bound group with the Earth-bound group in their transfer ride on the rover. Consideration must be given to waste disposal so as not to contaminate the site. After the Earth-bound group has left, the new group in the FLO will begin installation of their experiments, organization of their research, and their work in general. For that they will spend days number three and four.

From then on, a routine for ordinary days (37) will be established in a way that allows circadian cycles of the crew to stagger sleep and wake hours, so that there is always someone on duty. The last two days of the crew period will be dedicated to preparations for return to Earth and collection of data to close or transfer experiments to the incoming crew.

A typical 24-hour period in the life of a crew member includes a sleep period of six hours, followed by one hour for personal hygiene, breakfast, and a health maintenance check-up. All of these take place in the second level. Then there will be a period of four hours for work (research, operation, reports, etc.) in the third level, or EVA, in some instances. That would be followed by two hours of exercise, a meal, and a rest period of one hour in the second level. After that, crew members will take two hours for programmed or extemporaneous recreational activities, which will be followed by another period of four hours for work at the third level. The day will conclude with two more hours of exercise and one hour for a meal and another medical check-up.

During weekends, or every seven days of twenty-four hours, the typical day's routine will be interrupted by meetings of all four crew member, exchanges, and celebrations. These must be made to coincide also with the times of crew transfer at the beginning and end of the 45-day cycle. Crew transfer time must also coincide with

the lunar sunrise/sunset to insure proper illumination of landing/take-off sites.

Most of the crew work will be done inside the FLO (IVA), but there will be occasions that work will require extravehicular activity (EVA). For those times, there will be four suits with life support systems for four hours. Since work among crew members is staggered, not all of them will engage in EVA at the same time. Egress and ingress is through two hyperbaric chambers at the first level, which also contain a "car-wash"-type system to remove regolith dust particles from incoming astronauts as they enter from EVA. One of the chambers will be maintained in vacuum, as long as there is a crew member in EVA, to permit rapid reentry, if needed, while the other will be kept pressurized to permit the exit of a crew member to help those in EVA, when required.

Installation Process

The FLO habitat, a rounded-top vertical cylinder will be launched from Earth assembled with a lander folded underneath. As it descends on the moon, it will unfold hexapod supports that will be designed to accommodate to uneven terrains, and it will land unmanned on the surface of the moon in any of the sites being considered. It will deploy two arms (extended 100' by 10' wide) containing a solar energy collector array. The two arms will align themselves by rotating around the envelope body until they reach a position parallel to the North-South line, except at polar landing sites, and the flat surface of the arms will rotate following the sun for maximum exposure. This will recharge its batteries and will start ECLSS operation. Rotating around the oculus of the observatory in the apex will be segment-shaped panels for temperature control. Antennae, cameras, and other external attachments will be automatically deployed, and will signal to Earth the readiness of the habitat to receive a crew.

Then, a Crew Module transporting four astronauts will be launched to land at a distance of one kilometer from the habitat. It will be a conical vessel mounted over a similar lunar lander. The first crew will also have to carry a lunar surface rover, so that future crews will be able to transfer supplies from their landers to the FLO, and to deal with the problem of waste stowage. Every forty-five days a new crew will arrive, and the returning crew will

start its journey back to Earth in the same conical vehicle, which will be designed for reentry.

The FLO differs from the Apollo landings (a first generation of lunar bases) in that it will have an infrastructure of translunar vehicles capable of keeping a flow of astronauts for the 45-day mission cycles and capable of initiating rescue missions when necessary. Essentially it will be a permanently manned outpost for as long as it is resupplied from Earth. Thus, we can consider it to be the beginning of the second generation of lunar bases.

As technology for the development of recyclable biomes develop, the FLO will evolve by addition of plant growth and physicochemical modules, depending less upon Earth resupplies. The third generation of lunar bases will come into being when autosufficiency is attained.

Reduced Gravity Furniture

Partial gravity sitting posture research

Humans have developed a sitting posture adequate to Earth's gravity that has been a result of thousands of years of evolution. With the advent of the Space Age, a neutral body posture for a reduced gravity that differs from the Earth's gravity sitting posture was assessed. Humans have been on the moon, but they spent most of their time standing or on a seat or a hammock while inside their extraterrestrial vehicle. Therefore, the appropriate sitting posture for Lunar gravity is not known exactly. The Mars gravity sitting posture is also not fully understood. They are between the familiar sitting posture of Earth's gravity and the neutral body posture experienced in microgravity.

The KC-135 aircraft, NASA's reduced gravity simulator, was chosen to conduct the necessary tests for this kind of research because it can create a complete body experience in reduced gravity. The major disadvantage of this method is the limited time, approximately 30 seconds, of reduced gravity available continuously. On June 1991, a KC-135 flight experiment determined the best walking gait and sitting posture for Mars gravity. A regular office chair and an ergonomic chair were tested to determine their feasibility for use in a reduced gravity environment. Both of these chairs were secured to the floor of the

aircraft; no translation was possible. Swiveling was only done with the office chair, but was found to be difficult. The ergonomic chair tested had no provision for swiveling. These issues need to be investigated in the future. It was found that there was not enough friction between the body and the office chair to hold the person in place. A seat belt was suggested to secure the person to the chair, but using a seat belt each time one sits is not the best design solution. The ergonomic chair was more effective in securing the person. Better reach was achieved using it. But it was found that a heel rest was needed in order to maximize forward reach. The angle of the seat and the knee rest needed to be optimized for the partial gravity condition. For this purpose, a second generation sitting posture experiment was conducted in August 1991. This time the research was conducted in both Mars and Lunar gravity. The results of these tests are still being analyzed.

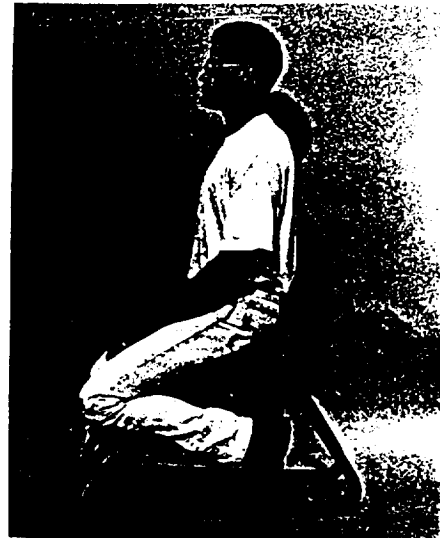

Fig. 2 Ergonomic chair

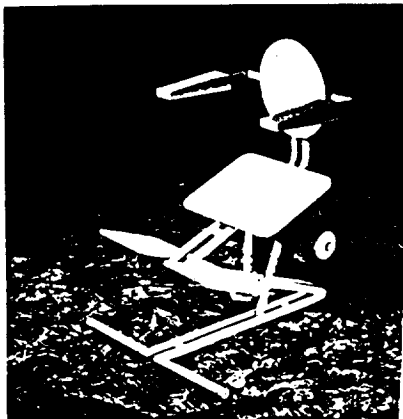

Fig. 3 A design alternative

Application of Habitability Criteria

Personal identification

Many astronauts and cosmonauts have expressed a need to feel that they are not engulfed in a cold impersonal dwelling that does not respond to their personal preferences in any way during their ventures into extraterrestrial space. They felt their environment should not only provide adequate protection for their survival, but should also have quality of life enhancements to make their experiences more significant and to support homeostasis in a way to make them more able to fulfill mission objectives efficiently. They should be viewed as part of the human family venturing into a new frontier and setting the pace that others will follow. Personal objects, such as portraits of loved ones and other momentos, will impart a homey character to the crew quarters of the FLO, which each crew member is able to influence with his or her own decoration. Because of the limited space of the FLO, the crew quarters is the only personal space available and should be viewed as a protective womb since it also serves as a safe haven in case of solar flare emergencies. It will be protected by high shielding and will contain additional survival necessities. Rescue portholes at the external end will ensure astronaut egress in case of total FLO failure. The size (6.5' x 4' x 4') is quite small by terrestrial room standards, but it seems capable of solving the need for personal identification. We have departed from

precedents set by Japanese hotel rooms, which are currently being used.

Social interaction

In prolonged stay in extraterrestrial space it seems very important for humans to feel the presence of others. Besides company and security, it is necessary to promote positive interpersonal dynamics and good social interaction. Crew quarters open to the wardroom, thus providing for the option of being able to share and interact even as each person chooses to leave the door open during normal operating conditions. The workroom, located between the galley and personal storage, will be the meeting place for the entire crew. The four members can sit around the table for meals and meetings, can watch videos, or look out on the lunar landscape through an adjacent porthole window.

Mental landscapes

Acute places are tight and small enclosed spaces, such as we have in the FLO, and generally in all living quarters in extraterrestrial space. On Earth we have the precedents in elevators, bathrooms, and in some temporary dwellings. Human behavior is modified, not only by the apparent size of volume of a dwelling, but also by the image that it conveys. Therefore it is important that they contain symbolic elements that would evoke positive memories and sensations from previous experiences. Such elements can be called mental gardens, or even landscapes, which help people to transcend their immediate physical reality. In the FLO, it will be attained by making the wardroom side of the second level the "home" of the crew. Colors, photographs, and images created in the galley and storage doors will accomplish that effect. One side of the crew quarters, toilet and washroom will be completely covered by a mirror, to enhance the apparent size of the space. On the gymnasium wall, monitors coordinated with the exercise machines will literally create programmed landscapes, which will stimulate crew members. The third level, which contains the work area, lighting, furniture, and other features, will be set as a command bridge of a vessel, from which all operations will be controlled. There will be four porthole windows, permitting a view of the actual landscape around the FLO. The first level, with its two hyperbaric chambers, will be the "entrance lobby", and as such is designed as a reception space for

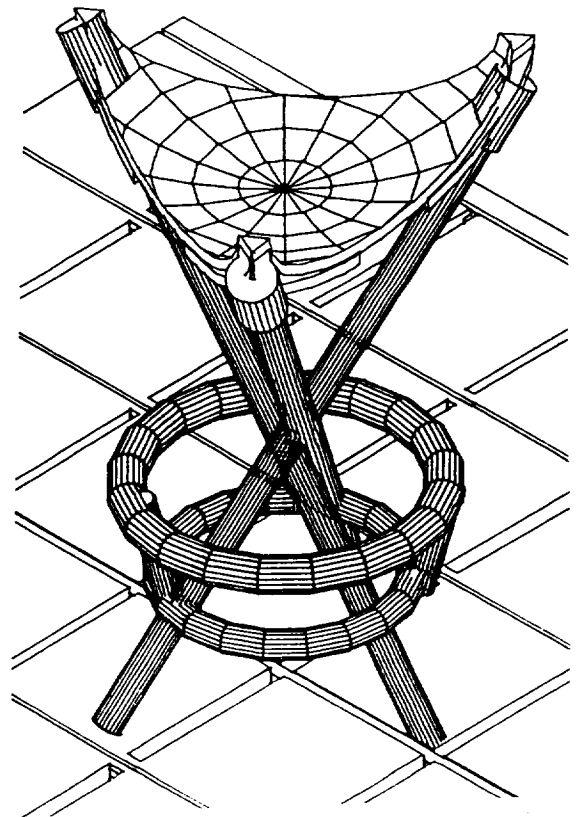
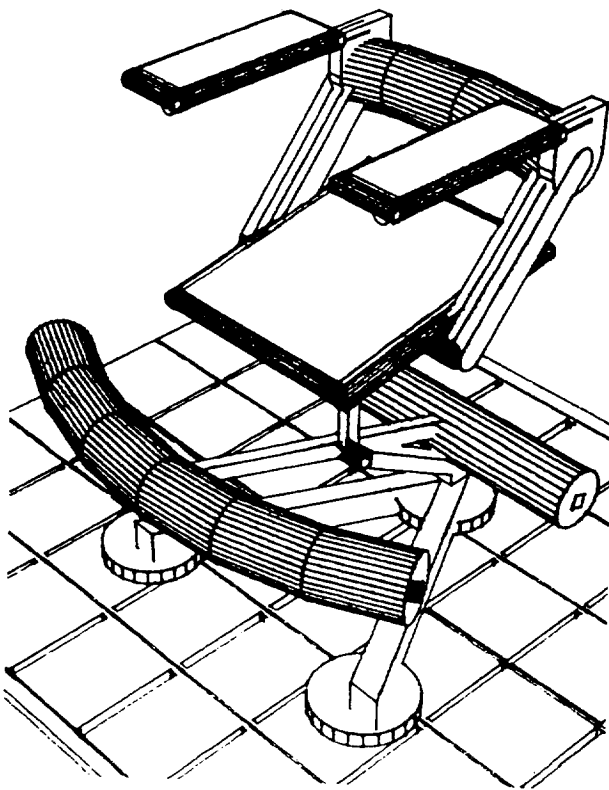
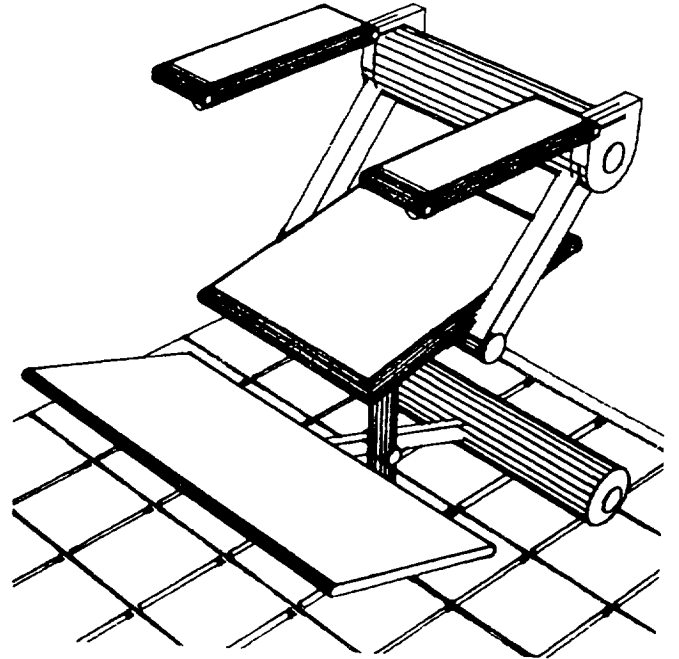
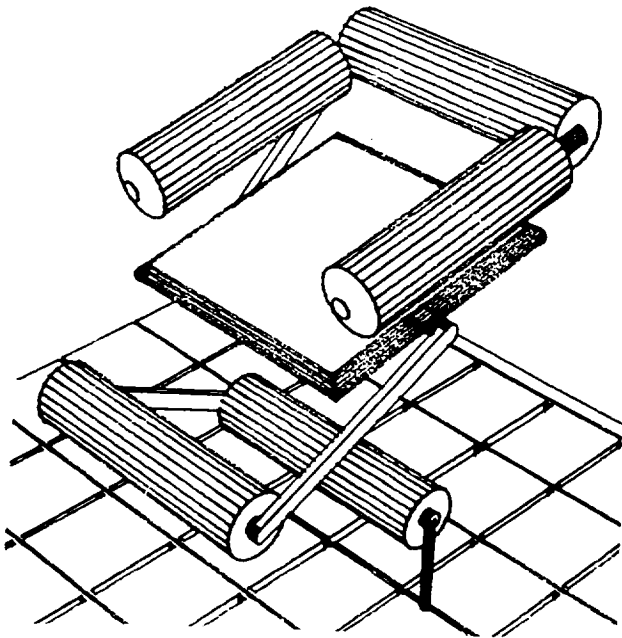

Fig. 4 Additional ergonomic chair design alternatives

incoming astronauts and the gateway for returning astronauts.

Privacy

Even though interaction dynamics among crew members should be promoted, they should be balanced by allowing a certain degree of privacy and occasions of solitude, since they will be living in close quarters for periods of forty-five days, as the mission requires. Absence of privacy is an important factor for humans in restricted environments. In the FLO each crew member has his or her assigned individual private area with sliding door that can be closed tightly. Personal hygiene areas also have doors, and there are four privacy curtains, which can subdivide the intermediate level into the health maintenance area, the gym, the locker-dressing area, and the galley.

Contact with nature

In previous studies this criterion was related to functioning biomes of closed environmental support systems (CELSS). The FLO, being a second generation lunar base, will not yet be self-sustaining, in that air, water, and food supplies will have to be shipped in every 45 days with each arriving group of astronauts. This way plant growth modules could be added to recycle protein for human consumption, oxygen, and water. But the biological growth in the FLO will be related to research, rather than to a CELSS. Nevertheless, we must be aware of the fact that individuals here will be exposed to prolonged immersion in a totally artificial environment. Absence of contact with natural or living things causes a destabilizing effect on humans. That could be offset by adding planters, fish bowls, and the like, which would not be directly or exclusively related to research in order to promote a healthy contact with nature. Soviet cosmonauts have expressed their enjoyment of flowering orchids in their space station.

Equalitarian conditions

Equalitarian conditions among crew promote more relaxed interpersonal relationships, making them more productive and attuned to the mission. Functional or role differentiation promotes better interaction than arbitrary rank or hierarchical distinctions. In architectural terms,

such equalitarian conditions are reflected in the quality, location, and size of the crew quarters.

Variability

Studies suggest that similar elements or very repetitive features in an acute place cause boredom and irritability, which are related to environmental stress. It is important that within the FLO there be a certain degree of variability. Architecturally this could be attained through changes in color and intensity of illumination. Circadian cycles could be maintained, if general illumination of the major interior spaces were programmed according to terrestrial day and night cycles. Decor in the three different levels corresponds also to their specific function; namely, access/egress, dwelling, and work correspond to gateway, home, and command bridge, respectively. Functional rotation of housekeeping duties among crew should also help to fulfill this criterion.

Aleatoric conditions

Astronauts and cosmonauts who have stayed for prolonged periods in space have expressed their appreciation for pleasant surprises, which depart from daily routine, and promote their enjoyment of unexpected changes. Crews will experience the need for celebrating special events (e.g. birthdays, holidays, etc.) between their arrivals and departures, thus, enhancing the routine of ordinary days. The sights through porthole windows, as a lunar landscape passes through day-night-day cycle and the rotation of the stars around the hovering Earth over the lunar horizon will be sights that the crew will behold, in addition to other new and unforeseen experiences. A fractal screen could be made to vary continuously in areas, such as the second level, to maintain the environmental excitement that the fulfillment of this criterion entails.

Functionality

A place to be habitable must also satisfy certain objective and measurable physical conditions. These are specified in the NASA STD-3000 Man-Systems Integration Standards, and include temperature, atmospheric pressure and composition, humidity level, and other life support parameters. It must include radiation, fire, and other hazard detection, warning, and protection. The possibility of sudden depressurization

due to envelope puncture or leakage must be considered. Ease of re-supply input and waste disposal through the airlocks in the first level, redundancy of systems hardware in the CELSS, airlocks, self-healing membranes, and a reasonable supply of spare parts and tools are also necessary to comply with this criterion.

Comfort

This criterion is related directly to the interaction of the human body, its form and size, with the artifacts and furniture. The size of the areas of the FLO also must be taken into account. In lunar gravity (1/6 G) human posture and movements are different from those which we find in the terrestrial environment. Before final design of the FLO, testing of the artifacts to be used on the moon through simulation must take place to gain a better understanding and insight regarding posture and motion in lunar gravity.

Stability and security

Stability refers to that inertia which resists unbalancing forces. Human muscle tone and reflexes developed in a normal 1G environment will find 1/6 G alien. Starting and stopping locomotion will be different. Horizontal circulation will have to be insured in the FLO by using textured floors that will enhance friction. Grab bars will promote the use of upper body muscles when rapid movements are necessary. Vertical circulation is proposed through the use of ladders with one-foot step separation. Such an alternative is being studied in water tank reduced-gravity simulations at NASA/JSC, as well as the capacity of a crew member to carry a load while ascending the ladder.

Sensorial Stimulation

FLO dwellers must not be deprived of sensorial stimulation, even in such a restricted environment. It is important that they have as close to normal, and as varied as possible, range of stimuli. Sensations are the primordial matter of experience. Surfaces in the FLO will be treated with colors to stimulate the eye and with textures that will stimulate the tactile sense, as well as to solve acoustical problems and the reduced friction problem mentioned earlier. Simulated landscapes and fractal artwork serve also as means of sensory stimulation. The olfactory gustatory senses must be accounted for in

the variety of smells and taste of the food supplied to the crew. Odor control in air handling units is a necessity in such confined a environment.

Music and environmental sound

The problem of absolute silence in extraterrestrial space is offset by the sound generated by the ECLSS. Fans and other sound sources will have to be tuned to produce a harmonious, agreeable, and pleasant sound at a level that contributes positively to the environment. Electronic sound masking will also be necessary to permit some conversations to be made privately and noise to be kept within acceptable limits. Within crew quarters there will be a stereophonic sound system that each crew member can control within his or her own space.

Sense of orientation

In reduced gravity this criterion is not as critical as it is in zero gravity, wherein an up and down direction orders the dwelling. However, color coding is still used to aid in orientation. Location of a color stimulus, be it on the ceiling, floor, or wall, can make a great difference in the character of the habitat, its perceived size, its sense of well-being, and psychological pleasantness. The FLO's interior walls will be mostly beige, which is a neutral color that can be modified easily by shining different colors of light on it according to circumstances, e.g., red blinking lights in an emergency. They could be varied randomly to improve the style and quality of life. Ceilings on public areas are peach to give a sense of warmth to the dwelling, and doors or interior airlocks, yellow. Crew quarters interiors may vary according to individual crew member preferences through changes in lighting, since it is mostly neutral, and blue doors. Machinery areas are gray, with safety orange doors on airlocks.

Conclusions

This study sustains the following conclusions we have reached pointing towards the direction in which the design of the First Lunar Outpost should develop:

Because of the greater volume functionality and empathy with the human form, the vertical cylinder is the most appropriate geometry for the habitat envelope.

Twenty-four-foot diameter in a three-level cylinder is adequate to house functions and living quarters of a crew of four for 45-day missions.

Locomotion within the habitat module will require textured surfaces, bars for upper body control, and special furniture design, taking into account reduced gravity body posture.

Still, there are many questions that need to be dealt with before the FLO can get to a final design stage:

Testing of tools and furniture in reduced gravity simulations is necessary to refine the data regarding body posture, anthropometry, and biomechanics in lunar gravity.

The transportation of supplies and waste stowage from the crew lander and FLO habitat will require a rover capable of traveling the one-km distance that exists between the two. This, including the modular containers that will carry food, clothes, air, and water that have to be outfitted for every incoming crew, has yet to be designed.

Foresight to deal with catastrophic conditions and accidents could lead to design adjustments that will improve chances for survival for the crew. These should be studied and analyzed in more specific detail.

Environmental lighting used to vary the character of this acute place; the use of holograms to enrich the environment, evoking mental landscapes; the use of fractals to induce variations in wall patterns, or ceiling surfaces; and the use of photosensitive membranes to create a new sense of indoor-outdoor by transparency variation within the habitat are some of the quality of life enhancements that could also be included in further design development.

Lifestyle considerations will bring forth new kinds of activities, pastimes, and recreation to enhance the routine of ordinary days and develop new forms of social interaction to satisfy needs of FLO dwellers.

Habitability criteria must be refined as new research brings new insights to be considered for the habitat design, so that the FLO can be truly another step in the path towards colonization of the Moon.

This work collects research, insights, and efforts of a group of people interested in the architectural implications of the return of humans to the Moon. By sharing them through this medium, we aspire to raise consciousness regarding the contribution that architectural designers can make for the conquest of space and to call upon others in that field to participate in the endeavor.

References

1. Angelo, J., The Extraterrestrial Encyclopedia, Facts on Life Publications, New York, 1985.
2. Allen, J., Biosphere 2, Penguin Books, New York, 1991.
3. Alred, J. et al., Lunar Outpost, Systems Definition Branch, Advanced Program Office, Johnson Space Center, Houston, 1989.
4. Andino, A., et al., Habitability: Camelot II, NASA/USRA Advanced Design Program, University of Puerto Rico, School of Architecture, June, 1989.
5. Andino, A., et al., Habitability: Camelot IV, NASA/USRA Advanced Design Program, University of Puerto Rico, School of Architecture, June, 1990.
6. Andino, A., et al., Selenia: A Habitability Study for the Development of a Third Generation Lunar Base, NASA/USRA Advanced Design Program, University of Puerto Rico, School of Architecture, June, 1991.
7. Gatland, K., Space Technology, Harmony Book, New York, 1981.
8. Heiken, G., Vaniman, D., French, B., Lunar Sourcebook: A User's Guide to the Moon, Cambridge University Press, Cambridge, 1990.
9. Johnson Engineering Corporation, Outfitting Concepts for Lunar Habitats, Houston, TX, 1989.
10. Johnson Engineering Corporation, New Initiatives Habitability Concepts, Houston, TX, 1989.

11. Kerrod, R., Living in Space, Crescent Books, New York, 1986.
12. Levedev, V., Diary of a Cosmonaut: 211 Days in Space, Phytoresource Research, Inc., Texas, 1988.
13. Mendell, W.W., Lunar Bases and Space Activities of the 21st Century, Lunar and Planetary Institute, Houston, Texas, 1985.
14. Moore, G.T., et al., Genesis Lunar Outpost, University of Wisconsin, Milwaukee, 1990.
15. National Aeronautics and Space Administration, Man-systems Integration Standards, NASA, STD-3000, Volumes I, Washington, D.C., 1989.
16. National Aeronautics and Space Administration, JSC Reduced Gravity Program: User's Guide, Houston, TX, 1987.
17. Prohansky, H., Environmental Psychology: Man and His Physical Setting, Holt, Reinhart, and Winston, Inc., New York, 1967.
18. Sasakawa International Center for Space Architecture (SICSA), Lunar Base Habitat Study, NASA/USRA Final Report, University of Houston's College of Architecture, Houston, TX, 1989.
19. Sasakawa International Center for Space Architecture (SICSA), The Manned Lunar Outpost, University of Houston's College of Architecture, Houston, TX, 1989.
20. Universities Space Research Association: Lunar and Planetary Information Bulletin, No. 58, Houston, February, 1991.