

V-12

NASA CASE NO. ARC 12030-1PRINT FIG 4

NOTICE

The invention disclosed in this document resulted from research in aeronautical and space activities performed under programs of the National Aeronautics and Space Administration. The invention is owned by NASA and is, therefore, available for licensing in accordance with the NASA Patent Licensing Regulation (14 Code of Federal Regulations 1245.2).

To encourage commercial utilization of NASA-owned inventions, it is NASA policy to grant licenses to commercial concerns. Although NASA encourages nonexclusive licensing to promote competition and achieve the widest possible utilization, NASA will consider the grant of a limited exclusive license, pursuant to the NASA Patent Licensing Regulations, when such a license will provide the necessary incentive to the licensee to achieve early practical application of the invention.

Address inquiries and all applications for license for this invention to NASA/Ames Research Center, Patent Counsel, Mail Stop 200-11, Moffett Field, CA 94035-1000.

Serial Number: 08/151,690
Filing Date: 11/15/93
Patent No: _____
Date Patent Issued: _____

NASA/ARC

(NASA-Case-ARC-12030-1) BOUNDARY
LAYER CONTROL DEVICE FOR DUCT
SILENCERS Patent Application
(NASA, Ames Research Center) 12 p

N94-29362

Unclas

G3/71 0003666

ARC-12030-1

Invention Abstract

BOUNDARY LAYER CONTROL DEVICE FOR DUCT SILENCERS

The present invention relates generally to noise reducing structures for use in wind tunnels and jet engines, and more particularly to the use of a fiberglass cloth in a silencer to enhance noise reduction.

Referring to Figures 1-3, a fiberglass cloth 20 is placed between a porous cover plate 12 and an acoustic absorber 16. The fiberglass cloth has a flow resistance with a specific range selected to be low enough to allow the sound to enter the absorber but to have sufficient flow resistance to dampen unsteady flow oscillations.

The present invention is differentiated from the prior art in that the addition of fiberglass cloth has a specific effect on controlling the boundary layer to result in further sound reductions. The invention has potential use in wind tunnels as test section silencers, as well as in jet engines for duct silencers.

INVENTORS: Fredric H. Schmitz

Paul T. Soderman

EMPLOYER: NASA-AMES RESEARCH CENTER

SERIAL NO.: 08/151,690

Filing Date: 11/15/93

Title

BOUNDARY-LAYER CONTROL DEVICE FOR DUCT SILENCERS

5 **Origin of the Invention**

10 The invention described herein was made by employees of the United States Government and may be manufactured and used by or for the Government for governmental purposes without the payment of any royalties thereon or therefor.

Background of the Invention

15 The present invention relates generally to noise abatement devices used in aeronautic applications and, more specifically, to a boundary-layer control device for air duct silencers and other aeroacoustic applications. A porous flow resistive membrane is interposed between a porous cover plate and an acoustic absorber. The
20 resistive membrane permits sound to enter the acoustic absorber while damping unsteady flow oscillations which would otherwise cause a thickening of the boundary layer. The resulting thinner boundary layer results in reduced flow-induced noise.

25

Technical Field of The Invention

30 It has been known to use silencing devices in connection with wind tunnel ducts, turning vanes, and other aeronautical structures such as the inlets of jet engines. As examples, U.S. Patent No. 5,151,311 to Parente et al. discloses an acoustic attenuating liner which includes a non-metallic honeycomb core bonded to a backsheet, a perforated sheet that is bonded to the honeycomb core, and a mesh woven metal bonded to the

perforated sheet. The liner is suggested for use in jet engines.

5 U.S. Patent No. 4,990,391 to Veta et al. discloses a laminate structure which includes a reticulated adhesive material between a honeycomb core and a perforated sheet, and an outer layer of wire screen or other porous fibrous material. During reticulation, the adhesive material tends to create voids in open areas and collect along the edges of the perforations in the perforated sheet, rather than flow along the surface of the perforated sheet. This changes the expected flow through resistance of the laminate structure, and is expected to result in noise reduction in aircraft applications.

10 U.S. Patent No. 4,522,859 to Blair discloses a method for manufacturing a honeycomb noise attenuation structure for high temperature applications. A central honeycomb cellular core is sandwiched between an imperforate and a perforate sheet. A sheet of porous metal overlay is included which is bonded to an outer surface of the perforated facing sheet. The sheet of porous metal overlay may be a wire cloth material or fibrous porous metal felt material.

15 U.S. Patent No. 4,353,947 to Northcutt discloses a laminated composite structure having a bottom layer of high tensile strength woven fibers impregnated with a thermosetting resin, a rigid cellular core, a sponge-like reservoir layer, and a top layer of high tensile strength woven fibers.

20 In general, the existing duct silencing materials are composed of perforated metal plate covering a honeycomb or similarly partitioned air space backed by a hard wall. As sound travels along the duct, it propagates into the

25
30

airspace behind the porous cover plate and is attenuated by viscous forces in the cavities and orifices. In some cases, the cavities contain bulk sound absorbing material.

5 While several attempts have been made to produce duct silencers capable of achieving ever greater reductions in noise, none heretofore have been able to achieve the desired noise reductions and low flow disturbance characteristics. Thus, a continuing need exists for an
10 improved silencer structure.

Summary of the Invention

The present inventors have discovered that, in the prior art devices described above, interaction of the
15 airflow with the cavities being the porous cover plate create oscillations in the boundary layer on the surface of the silencer. The oscillations cause the boundary layer to thicken relative to a boundary layer that would exist over a smooth hard surface. The flow oscillations
20 are especially vigorous if resonance is excited between the external airflow and the air in the honeycomb or similarly partitioned cavities. Resonance, which can be triggered by the airflow or by acoustic waves, can generate small jets of air to pump into the duct and
25 perturb the main airflow. The resulting thick, turbulent boundary layer can create large unsteady loads on downstream fans or vanes and create loud noise. In addition, the thick boundary layers absorb energy from the air moving system.

30 Thus, an object of the present invention is to provide an apparatus for controlling and minimizing the boundary-layer growth caused by airflow over duct

silencers, thereby resulting in a reduction of noise caused by the unsteady loading of the fan by the boundary layer.

5 Another object of the present invention is to provide a boundary-layer control device for duct silencers which is relatively simple in construction. These and other objects of the invention are met by providing a boundary-layer control device which includes a porous cover plate, an acoustic absorber, and a porous flow resistive membrane
10 interposed between the porous cover plate and the acoustic absorber. The resistive membrane having a flow resistance low enough to permit sound to enter the acoustic absorber and high enough to damp unsteady flow oscillations.

15 Other objects, advantages and salient features of the invention will become apparent from the following detailed description, which, taken in conjunction with the annexed drawings, discloses preferred embodiments of the invention.

20 **Brief Description of the Drawings**

Figure 1 is a front schematic view of a jet engine employing the boundary-layer control device according to the present invention;

25 Figure 2 is an enlarged partial top plan view, partially cut-away, of the boundary-layer control device of Figure 1;

Figure 3 is a sectional view taken along line 3-3 of Figure 2;

30 Figure 4 is a front schematic perspective view of a wind tunnel section employing the boundary-layer control device according to another embodiment of the present invention;

Figure 5 is an enlarged partial top plan view, partially cut-away, of the boundary-layer control device of Figure 4; and

5 Figure 6 is a partial sectional view taken along line 6-6 of Figure 5.

Detailed Description of the Invention

Referring to Figures 1-3, a boundary-layer control device 10, installed in the duct inner wall of a turbo-fan engine 11 between the inlet lip and the fan blades, includes a porous cover plate 12 having a plurality of perforations, an acoustic absorber 16 having a plurality of primary air cavities 18 disposed under the porous cover plate 12, and a porous flow resistive membrane 20 interposed between the porous cover plate 12 and the acoustic absorber 16. Airflow is indicated by the directional arrow labeled "A". The device 10 is preferably annularly formed around the inlet of the jet engine in the nacelle at the inlet lip.

20 The acoustic absorber 16 is preferably a honeycomb structure in which a plurality of aluminum partition walls define the air cavities, which have an open upper end. The lower end of the air cavities is covered by a backwall 22 which is fixedly connected to the partition walls of the air cavities.

25 The porous flow resistive membrane 20 has a flow resistance low enough to permit sound to enter the acoustic absorber 16 and high enough to damp unsteady flow oscillations. This can be achieved by using a material having a flow resistance between 210 and 500 mks rays. A particularly preferred material is 1675 fiberglass cloth, such as "J.P.Stevens Style 1675 Fiberglass Cloth". This

30

material is a woven cloth having a thickness less than that of burlap, and a texture somewhat like course linen. Alternative membrane materials include screen, a thin fiberglass blanket, sintered metal, or any other porous material that has a flow resistance appropriate for passing sound and attenuating hydrodynamic fluctuations.

The cloth is positioned flush with the underside of the porous cover plate 12, and may be inserted between the honeycomb absorber 16 and the cover plate 12 prior to bonding the later two components together. It may be appropriate in some applications to position the cloth or similar resistive membrane at some distance from the porous cover plate 12. As long as the resistive membrane 20 separates the cover plate 12 from the primary silencer cavities 18 of the acoustic absorber 16, attenuation of the flow oscillations will result.

Attenuation of the flow oscillations at the surface of the duct silencer creates a thinner boundary-layer than would otherwise be created by airflow. The thinner boundary layer will save energy and reduce noise generated by the boundary-layer itself and downstream fans, compressors, vanes, or other bodies which interact with the boundary layer. The thinner boundary-layer will result in lower drag and energy loss of the system whether the intended use is for a duct silencer for a jet engine or for a wind tunnel acoustic lining, or other aeronautical applications.

The perforations 14 in the cover plate 12 are preferably one sixteenth of an inch or smaller in diameter. The cover plate 12 is preferably made of aluminum, and about 40% of the surface of the cover plate is open due to the perforations. The porosity of the

plate 12, as well as the size of the perforations, do not form part of the present invention. Conventional cover plates for jet engine applications can be employed.

5 Referring now to Figures 4-6, a silencer 24 for a wind tunnel 26 includes a porous cover plate 28 having a plurality of perforations 30, an acoustic absorber 32, a grating 34 disposed above the acoustic absorber 32, and a porous flow resistive membrane 36 disposed between the porous cover plate 28 and the grating 34. Grating 34
10 comprises spaced, parallel slats 44 and spaced, parallel crossbars 45. Airflow is indicated by the directional arrow labeled "A". A backwall 38 is spaced from and connected to the grating 34 through any suitable structure such as struts 40 and 42. The absorber 32 is disposed in
15 the space between the backwall 38 and grating 34.

The perforations 30 in the cover plate are preferably between one sixteenth and one eighth of an inch in diameter and comprise 40-60% of the surface area of the plate, which is preferably made of aluminum or steel.

20 The porous flow resistive membrane 36 has a flow resistance low enough to permit sound to enter the acoustic absorber 32 through the grating 34 and high enough to damp unsteady flow oscillations. As in the previous embodiment, the membrane 36 has a flow
25 resistance between 10 and 500 mks rayls. A particularly preferred material is 1675 fiberglass cloth, such as "J.P.Stevens Style 1675 Fiberglass Cloth". The cloth is positioned flush with the underside of the porous cover plate 28. Alternative membrane materials include screen,
30 sintered metal, or any other porous material that has a flow resistance appropriate for passing sound and attenuating aerodynamic fluctuations.

The acoustic absorber 32 can be loose fiberglass, fiberglass strips with a triangular corss section, or other sound absorbing material. The absorber backing is preferably a solid back wall 38.

5 In the illustrated embodiment, the entire test section of the wind tunnel 26 is lined with silencer 24, although only the floor needs to have the grating 34 to support models, test equipment and personnel. Air may freely pass through the slats and crossbars of the
10 grating. The side walls and ceiling need not include the grating 34, since its purpose is primarily to provide structural support.

15 While advantageous embodiments have been chosen to illustrate the invention, it will be understood by those skilled in the art that various changes and modifications can be made therein without departing from the scope of the invention as defined in the appended claims.

BOUNDARY-LAYER CONTROL DEVICE FOR DUCT SILENCERS

Abstract

5 A boundary-layer control device includes a porous
cover plate, an acoustic absorber disposed under the
porous cover plate, and a porous flow resistive membrane
interposed between the porous cover plate and the acoustic
absorber. The porous flow resistive membrane has a flow
10 resistance low enough to permit sound to enter the
acoustic absorber and high enough to damp unsteady flow
oscillations.

FIG. 1

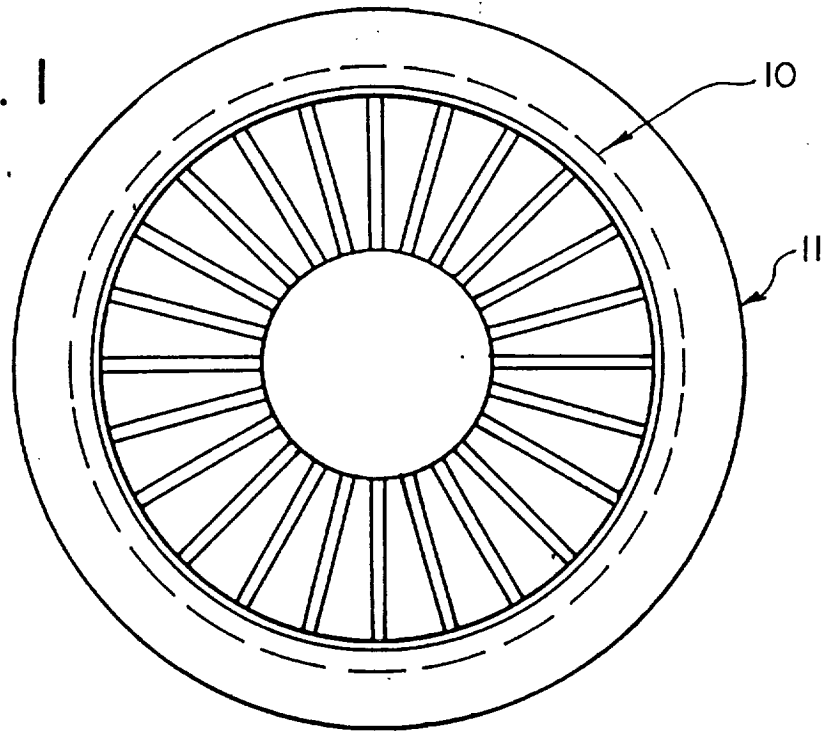

FIG. 2

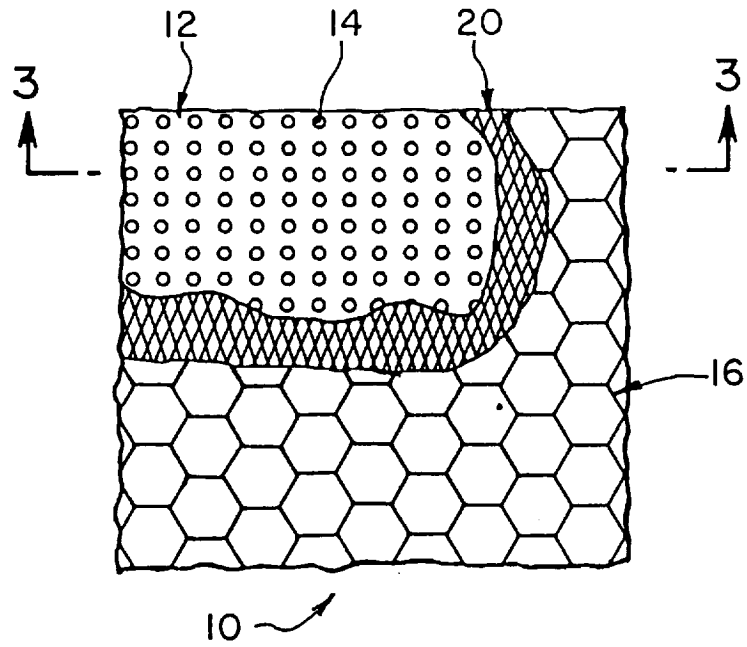

FIG. 3

