

NOTICE

THIS DOCUMENT HAS BEEN REPRODUCED FROM
MICROFICHE. ALTHOUGH IT IS RECOGNIZED THAT
CERTAIN PORTIONS ARE ILLEGIBLE, IT IS BEING RELEASED
IN THE INTEREST OF MAKING AVAILABLE AS MUCH
INFORMATION AS POSSIBLE

This microfiche was produced according to ANSI / AIIM Standards and meets the quality specifications contained therein. A poor blowback image is the result of the characteristics of the original document.

P-19

NASA CASE NO. MFS-28773-1
PRINT FIG. #1

NOTICE

The invention disclosed in this document resulted from research in aeronautical and space activities performed under programs of the National Aeronautics and Space Administration. The invention is owned by NASA and is, therefore, available for licensing in accordance with the NASA Patent Licensing Regulation (14 Code of Federal Regulations 1245.2).

To encourage commercial utilization of NASA-owned inventions, it is NASA policy to grant licenses to commercial concerns. Although NASA encourages nonexclusive licensing to promote competition and achieve the widest possible utilization, NASA will consider the granting of a limited exclusive license, pursuant to the NASA Patent Licensing Regulations, when such a license will provide the necessary incentive to the licensee to achieve early practical application of the invention.

Address inquiries and all applications for license for this invention to NASA/Marshall Space Flight Center, Patent Counsel, Mail Code CC01, Marshall Space Flight Center, AL 35812. Approved NASA forms for application for nonexclusive or exclusive license are available from the above address.

Serial Number 08/117,587

Filing Date September 7, 1993

NASA/MSFC	(NASA-Case-MFS-28773-1) APPARATUS FOR TESTING HIGH PRESSURE INJECTOR ELEMENTS Patent Application (NASA. Marshall Space Flight Center) 19 p	N94-29365
		Unclass

**APPARATUS FOR TESTING HIGH
PRESSURE INJECTOR ELEMENTS**

This invention relates to an apparatus for evaluating the performance and stability characteristics of high pressure fluid injector elements. The invention provides an improved and low cost apparatus for testing and evaluating the spray patterns of fluid injector elements when placed under high pressure.

Referring now to Figure 1, reference numeral 10 designates a preferred embodiment of the high pressure fluid injector test apparatus for evaluating an injector element 32. Apparatus 10 comprises an upper hub 42 including first boss 44 and second boss 46 therethrough, an upper weldment or housing 12 having a pair of ports 14 and an injector chamber 49, a first clamp and stud/nut assembly 48 for securing upper weldment 12 to upper hub 42, a standoff assembly 22 within upper weldment 12, a purge plate 30 secured to lower end 25 of standoff assembly 22, a series of equally spaced openings 68 in purge plate 30, an injector block assembly 26, having a boss 28, secured to the upper surface 65 of purge plate 30 for supporting the injector element 32 undergoing evaluation, a tube assembly 34 connecting first boss 44 and boss 28, a window housing 36 mounted within each port 14 and having a view glass 38 and boss 40 therein, a lower weldment or housing 52, a second clamp and stud/nut assembly 56 for securing lower weldment 52 to upper weldment 12, a lower hub 58, and a third clamp and stud/nut assembly 62 from securing lower hub 58 to lower weldment 52. In operation, fluid representing fuel is fed into first boss 44

of upper hub 42, through tube assembly 34 and injector block assembly 26, into injector element 32. Simultaneously, gaseous nitrogen (GN_2) is introduced through bosses 40 and 46 so that mist from the injected fluid (simulating a fuel) will not obscure viewing of the injector element 32 from the ports 14.

The novelty of this invention resides in the ability to purge the area surrounding the injector element 32 as well as the interior and exterior of the view ports to enable unobstructed viewing of the injector element 32.

INVENTORS: WILLIAM NEILL MYERS
 EWELL M. SCOTT
 JOHN C. FORBES
 MICHAEL D. SHADOAN

EMPLOYER: NASA/MSFC

DATE FILED: SEPTEMBER 7, 1993

SERIAL NUMBER: 08/117,587

MFS-28773-1

PATENT APPLICATION

**APPARATUS FOR TESTING HIGH PRESSURE
INJECTOR ELEMENTS**

ORIGIN OF THE INVENTION

This invention was made by employees of the United States Government and may be manufactured and used by or for the Government for governmental purposes without the payment of
5 any royalties.

BACKGROUND OF THE INVENTION

1. Field Of the Invention.

The present invention relates to an apparatus for testing high pressure fluid injector elements. The invention
10 provides an improved and low cost apparatus for testing and evaluating the spray patterns of fluid injector elements when placed under high pressure.

2. Description Of Related Art.

In the past, fluid injector elements were normally
15 tested by use of a low pressure apparatus or rig to evaluate the performance and stability characteristics of the injector element. The known prior art apparatuses for testing injector elements had numerous disadvantages and drawbacks in that they normally were restricted to tests under low pressure; they had
20 restrictions respecting their back pressure capability; they could utilize only one fluid during each test; their view ports were positioned one hundred eighty degrees (180°) apart, thus preventing optimum use of laser diagnostics; and they did not provide a purge to prevent mist from obscuring the

injector element or to prevent frosting of the view windows.

SUMMARY OF THE INVENTION

According to the present invention, there is provided an apparatus for testing and evaluating the spray patterns of
5 fluid injector elements which are placed under high pressure. The high pressure fluid injector test apparatus includes an upper hub, an upper weldment or housing, a first clamp and stud/nut assembly for securing the upper hub to the upper weldment, a standoff assembly within the upper weldment, a
10 pair of window housings within the upper weldment, an injector block assembly and purge plate within the upper weldment for holding an injector element to be tested and evaluated, a lower weldment or housing, a second clamp and stud/nut assembly for securing the lower weldment to the upper
15 weldment, a lower hub, a third clamp and stud/nut assembly for securing the lower hub to the lower weldment, means for introducing fluid under high pressure for testing an injector element, and means for purging the apparatus to prevent frosting of view glasses within the window housings.

20 Accordingly, it is an object of the present invention to provide a versatile and robust apparatus for testing fluid injector elements under high pressure.

Another object of the present invention is to provide an apparatus for testing fluid injector elements which allows the
25 purging of areas surrounding the injector element being evaluated and the view windows to permit unobscured viewing of

the element during testing.

It is still a further object of the present invention to provide an apparatus for testing fluid injector elements by the simultaneous use of two fluids during the test.

5 The above objects and advantages of the present invention will become readily apparent to those skilled in the art to which the invention pertains from a study of the preferred embodiments as set forth in the specification, drawings and appended claims.

10 , BRIEF DESCRIPTION OF THE DRAWINGS

Figure 1 is a partially sectional front elevational view of a first embodiment of the apparatus for testing high pressure injector elements.

15 Figure 2 is a top view of the purge plate utilized in testing the apparatus of the present invention.

Figure 3 is a cross-sectional view of the purge plate utilized in the testing apparatus of the present invention taken along line 3-3 of Figure 2.

20 Figure 4 is a front view of the clamp and stud/nut assemblies utilized with the testing apparatus of the present invention.

25 Figure 5 is a side elevational view of a portion of the clamp and stud/nut assemblies utilized with the testing apparatus of the present invention taken along line 5-5 of Figure 4.

Figure 6 is a partially broken away, sectional, front

elevational view of the upper portion of a second embodiment of the apparatus for testing high pressure injector elements which allows separate test fluids to simultaneously enter the injector element undergoing tests.

5 Figure 7 is a cross-sectional view of a typical injector element to be tested with the first embodiment of the invention as depicted in Figures 1 - 5.

 Figure 8 is a cross-sectional view of a typical injector element with fuel sleeve to be tested with the second
10 embodiment of the invention as depicted in Figure 6.

DESCRIPTION OF THE PREFERRED EMBODIMENTS

 Referring now to Figure 1 of the drawings, reference numeral 10 generally designates the high pressure fluid injector test apparatus of the present invention. Apparatus 10
15 generally includes an upper hub 42, an upper weldment or housing 12, a first clamp and stud/nut assembly 48 for securing upper hub 42 to upper weldment 12, a standoff assembly 22 within upper weldment 12, a pair of window housings 36 within upper weldment 12, a lower weldment or
20 housing 52 secured to the upper weldment 12 by a second clamp and stud/nut assembly 56, a lower hub 58, and a third clamp and stud/nut assembly 62 for securing lower hub 58 to lower weldment 42.

 The upper weldment 12 is generally hollow and cylindrical
25 and includes a protruding shoulder 11 at each of its extreme ends (not numbered), a central bore 13, a pair of laterally

extending ports 14, each having a bore 15 and a boss 16 therein. In Figure 1, the ports 14 are shown as being located one hundred eighty degrees (180°) apart; however, they could be located differently, such as one hundred fifty degrees (150°) apart. Upper hub 42 includes a protruding shoulder 43 extending from its lower extreme end (not numbered) and a top 45 having a first boss 44 for receiving a fitting 47 which allows the test fluid to enter injector element test apparatus 10 and a second boss 46 for receiving a fitting (not shown) for introducing gaseous nitrogen (GN_2) or any other suitable gas into apparatus 10 for reasons explained hereinbelow. Each window housing 36 is generally cylindrical and has an outer flange 35, a laterally projecting sleeve portion 37, a view glass 38 and a laterally extending boss 40 for purposes to be later explained which extends through each of outer flanges 35, respective laterally projecting sleeve 37, passages 41 and annular grooves 55. A plurality of second bosses 18 are in the walls of upper weldment 12 in general alignment with the bore 15 of laterally extending ports 14 for attaching test instruments (not shown). The ports 14 are purged with GN_2 through its bosses 16 for preventing external frosting of view glasses 38. Standoff assembly 22 includes a hollow and generally cylindrical member 21 provided with an upper end 23 and a lower end 25 and having a purge plate 30 attached to the lower end 25 thereof by a plurality of threaded screws 27. Standoff assembly 22 further includes an injector block

assembly 26 secured to purge plate 30 by a plurality of threaded screws 29 which pass through countersunk openings of purge plate 30. As best shown in Figures 2 and 3, purge plate 30 is circular and includes a lower side 63, an upper side 65, a plurality of countersunk openings 64 adjacent its outer edge, a central opening 67, a plurality of countersunk openings 66 outside of central opening 65 and inside of openings 64, a plurality of equally spaced, canted, openings 68 therethrough directed inwardly and outwardly at angles from upper side 65 to lower side 63 (Figure 3) for permitting the GN_2 which was injected through boss 46 to pass through purge plate 30. Injector block assembly 26 is generally inversed, cup-shaped, and includes a cavity 31 therein in communication with a boss 28 and fitting 39 extending from the top 33 of injector block assembly 26 and an injector plate 24 mounted within the opened end (not numbered) of the injector block assembly 26. An injector element 32 to be tested is mounted in the lower portion of the injector block assembly 26 in communication with cavity 31 of the injector block assembly and an injection chamber 49 provided in the lower portion of upper weldment housing 12. The injector element 32 includes an upper end 70, an inlet 71, and an outlet 73 (Figure 7) and is secured to the injector plate 24 within an opening (not numbered) therein by any suitable means such as brazing with the lower end 72 of injector element 32 being extended through central opening 67 of purge plate 30 into chamber 49. A tube

assembly 34 connects boss 44 in upper hub 45 and boss 28 with fitting 39 in injector block assembly 26. A plurality of lugs 20 are secured to the outer walls of the laterally extending ports 14 for mounting the apparatus 10 to an appropriate fixture. Lower weldment or housing 52 includes a protruding shoulder (not shown) similar to shoulders 11 of upper weldment 12 at each of its extreme ends (not numbered), a hollow central bore 53 and a laterally extending purge exit boss 54 in communication with hollow central bore 53. Lower hub 58 is generally cup-shaped and includes a protruding shoulder (not shown) similar to the protruding shoulder 43 of upper hub 42 and an opening in its closed end for supporting a fluid exit boss 60. A conventional seal 50 is mounted between upper weldment 12, upper hub 42, and standoff assembly 22 for sealing purposes. As best shown in Figures 4 and 5, the first clamp and stud/nut assembly 48 (as do the assemblies 56 and 62) comprises a pair of clamping segments 74, four bolts 76 and four nuts 78. Assemblies 48, 56 and 62 are known as GRAYLOC clamps, Part No. 70446, and are readily available from Vetco Gray, Inc., Houston, Texas. The first clamp and stud/nut assembly 48 engages the outer surfaces of upper protruding shoulder 11 of upper weldment 12 and the protruding shoulder 43 of upper hub 42 and due to a camming effect between the shoulders and the assembly 48, the seal 50 is compressed to seal the area between the protruding shoulders 11 and 43 of upper weldment 12 and upper hub 42. A seal (not shown),

similar to seal 50, is likewise used with second clamp and stud/nut assembly 56 to seal the area between the lower end of upper weldment 12 and the upper end of lower weldment 52. A seal (not shown), likewise similar to seal 50, is used with
5 third clamp and stud/nut assembly 62 to seal the area between the lower end weldment 12 and the laterally protruding shoulder (not shown) of lower hub 58.

With the fluid injector test apparatus 10 fully assembled as shown in Figure 1 except for the upper hub 42, the first
10 clamp and stud/nut assembly 48, the seal 50, the injector block assembly 26, the purge plate 30 and their associated parts, the operation of the embodiment of the invention depicted in Figure 1 to evaluate an injector element 32 would proceed as follows: The upper end 23 of standoff assembly 22
15 is secured to upper hub 42 by screws 51; the injector element 32 which has been secured to the injector plate 24 is then placed within the injector block assembly 26; the injector block assembly 26 is then secured to purge plate 30 by screws 29; the tube assembly 34 is connected to boss 44 and fitting
20 47 in upper hub 42 and to fitting 39 in boss 28 of block assembly 26; the purge plate 30 is secured to standoff assembly 22 by screws 27 at which time the upper hub 42, the standoff assembly 22, the tube assembly 34, the injector block assembly 26 and purge plate 30 form an integral unit. This
25 integral unit is then inserted into the central bore 13 of upper weldment 12 and with the protruding shoulder 43 of upper

hub 42 being firmly secured and sealed to the upper protruding shoulder 11 of upper weldment 12 by first clamp and stud/nut assembly 48. When the setup is complete, a test run is made. Fluid representing ^{an oxidizer} ~~the fuel~~ which pass through injector element 32 being tested is fed into the injector block assembly 26 through boss 44 and tube assembly 34. At the same time GN₂ gas is introduced through bosses 16, 40 and 46 so that mist from the injected fluids will not obscure viewing of the injector element 32. GN₂ introduced through boss 46 of upper hub 42 passes through the several angled openings 68 in purge plate 30 to reach the area within chamber 49 of apparatus 10 located below purge plate 30. GN₂ introduced through boss 40 passes through passages 41 (Figure 1) in the wall of port 14 to reach the internal surfaces of view glasses 38 via an annular groove 55 in the wall. Data is gathered to evaluate the performance spray parameters of the injector element 32 to enable better mixing and burning of propellants. At the completion of the test, the injector element test assembly is shut down, and the fluids are drained from the high pressure injector element test apparatus through purge exit boss 54 and fluid exit boss 60.

The second embodiment of the invention as depicted in Figures 6 and 8 differs from the first embodiment as depicted in Figure 1 primarily in the configuration of the injector block assembly 80 to enable two separate test fluids (simulating both fuel and an oxidizer) to enter the injector

J C J
09/02/93
EM 5
04/02/93

unin
/2/93

D.S.
/2/93

element undergoing tests, the addition of a fuel sleeve 94 to the injector element 96 which has an inlet 93 and an outlet 97, and the addition of a cup shaped housing 98 for containing the fuel being fed to the injector element 96. In the 5 embodiment depicted in Figures 6 and 8, some reference numerals (e.g. 14,15, 16, 30, 36, 40, 49, and 55) refer to identical components as depicted and described for the embodiment set forth in Figures 1-5. In the second embodiment, reference numeral 80 designate the modified injector block 10 assembly which includes a first boss 82 and a second boss 84 therein. The first boss 82 is in communication with a fitting 83 connected to a tube assembly 85 in communication with a boss 86 having a fitting 91 therein in upper hub 87 which allows a fluid simulating ^{an oxidizer} ~~a fuel~~ to enter the injector block 15 assembly 80 of the test apparatus 10. The second boss 84 is in communication with a fitting 88 connected to a tube assembly 89 in communication with a boss 90 having a fitting 92 in upper hub 87 which allows a fluid simulating ^{a fuel} ~~an oxidizer~~ to enter the injector block assembly 80 of test apparatus 10. In 20 the second embodiment as depicted in Figures 6 and 8, the upper end (not numbered) of fuel sleeve 94 is secured to flange 99 of injector element 96 by any conventional means such as brazing; the upper end (not numbered) of cup shaped housing 98 is secured to the bottom surface (not numbered) of 25 injector block assembly 80 by any conventional means such as brazing; and the lower end of fuel sleeve 94 is secured to a

J.C.F.
09/02/93
E.M.S.
04/02/93

J.C.F.
09/02/93
E.M.S.
04/02/93

Wnm
9/2/93
MOS
9/2/93

Wnm
9/2/93
MOS
9/2/93

central opening 100 in the bottom of cup shaped housing 98 by any conventional means such as brazing. In the second embodiment, fuel sleeve 94 is hollow and has a series of spaced openings 95 therein for allowing fuel to leave the cup shaped housing 98 to mix with the oxidizer being fed through the injector element 96 adjacent the outlet 97. The fuel and oxidizer is injected into the injector chamber 49 of upper weldment housing 12 to be observed and analyzed through window housings 32, as described supra. The second embodiment of test apparatus 10 operates substantially the same as explained hereinabove for the first embodiment except that two separate and distinct fluids which simulate a fuel and oxidizer are utilized during the test, with the fuel being introduced through fitting 92, boss 90, tube assembly 89, fitting 88, boss 84, cup-shaped housing 98, spaced openings 95, and through outlet 97 and the oxidizer being introduced through fitting 91, boss 86, tube assembly 85, fitting 83, boss 82, inlet 93, and outlet 97.

While the above description constitutes the preferred embodiments of the present invention, it will be appreciated that the invention is susceptible to modification, variation and change without departing from the proper scope and fair meaning of the accompanying claims. For example, it is readily apparent that the upper weldment 12 can be modified to provide various view post orientations. Furthermore, it is apparent that virtually any type/size of injector element can be tested

by apparatus 10 by modifying the injector block assembly.

ABSTRACT OF THE DISCLOSURE

An apparatus for testing and evaluating the spray pattern of high pressure fuel injector elements for use in supplying fuel to combustion engines.

5 Prior art fuel injector elements were normally tested by use of low pressure apparatuses which did not provide a purge to prevent mist from obscuring the injector element or to prevent frosting of the view windows; could utilize only one fluid during each test; and had their viewing ports positioned
10 one hundred eighty (180°) apart, thus preventing optimum use of laser diagnostics.

The high pressure fluid injector test apparatus includes an upper hub, an upper weldment or housing, a first clamp and stud/nut assembly for securing the upper hub to the upper
15 weldment, a standoff assembly within the upper weldment, a pair of window housings having view glasses within the upper weldment, an injector block assembly and purge plate within the upper weldment for holding an injector element to be tested and evaluated, a lower weldment or housing, a second
20 clamp and stud/nut assembly for securing the lower weldment to the upper weldment, a lower hub, a third clamp and stud/nut assembly for securing the lower hub to the lower weldment, mechanisms for introducing fluid under high pressure for testing an injector element, and mechanisms for purging the
25 apparatus to prevent frosting of view glasses within the window housings and to permit unobstructed viewing of the

injector element.

5 (PRESSURE.APP)

14
~~21~~

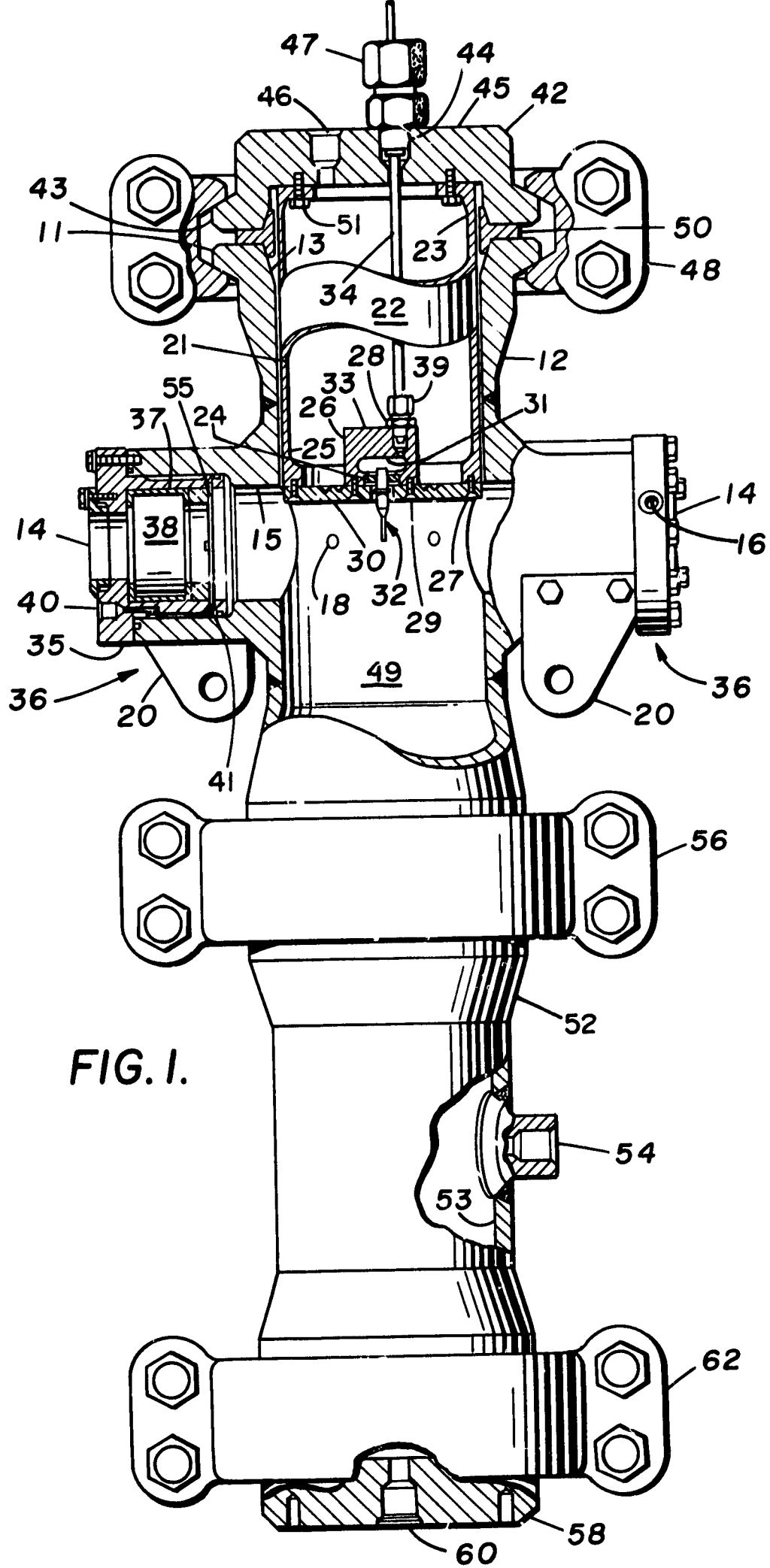

FIG. I.

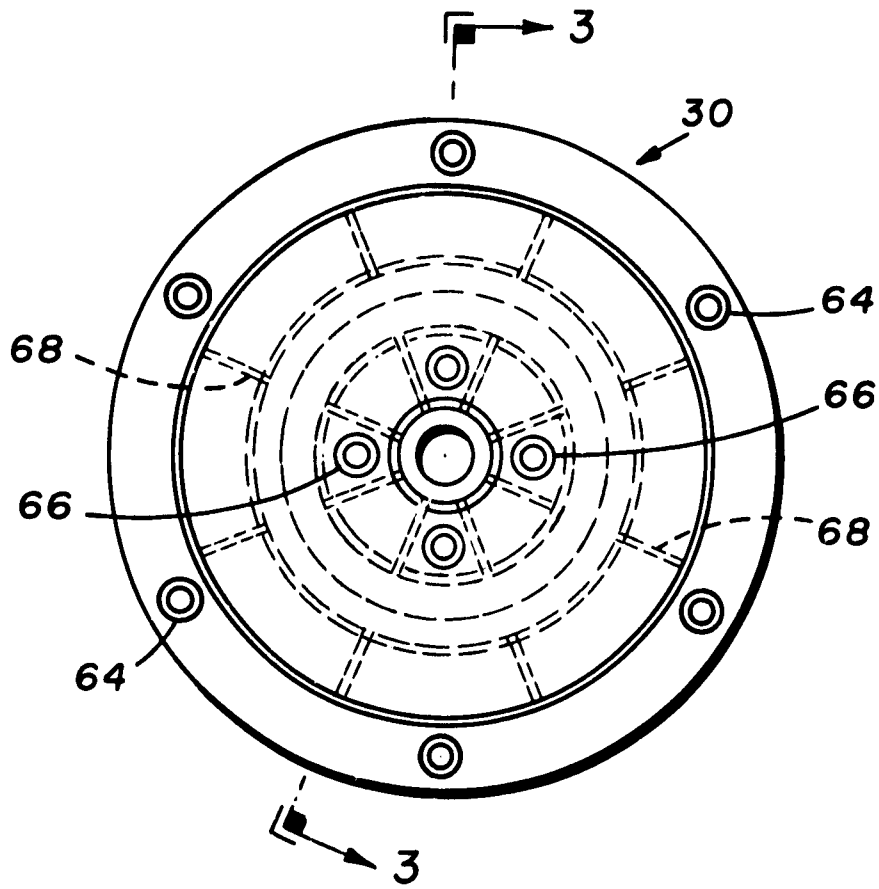

FIG. 2.

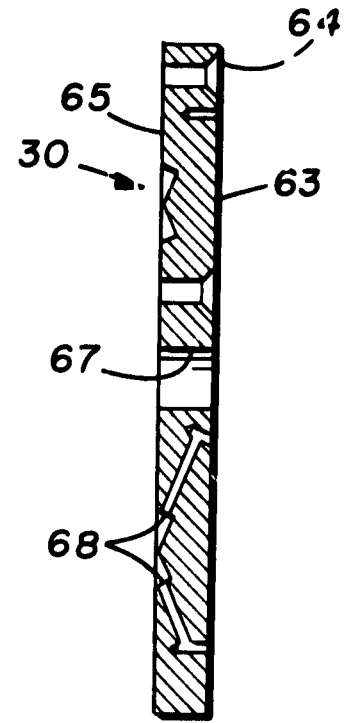

FIG. 3.

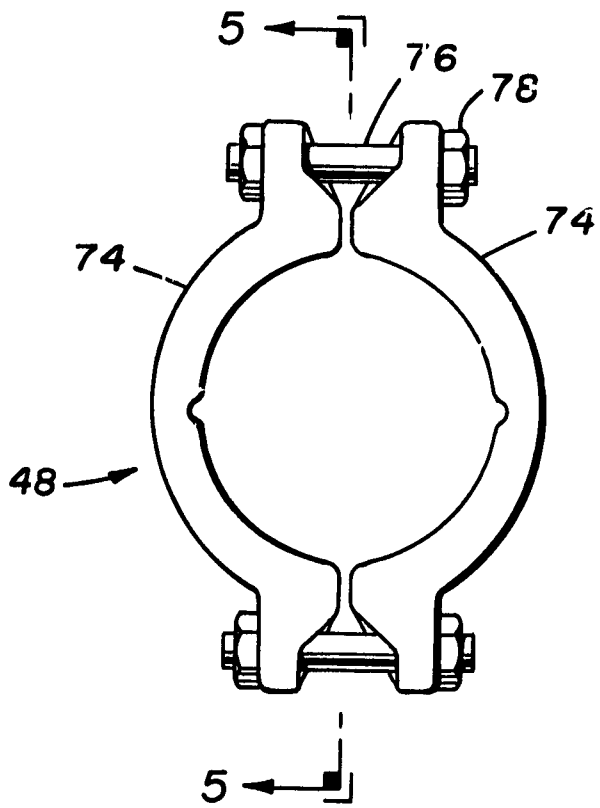

FIG. 4.

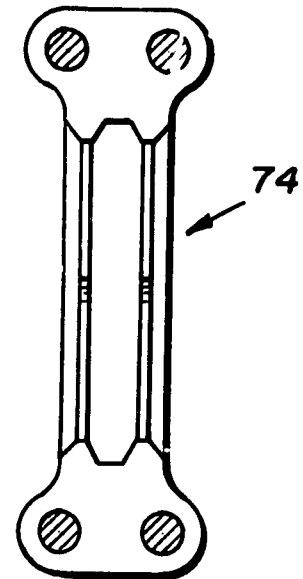

FIG. 5.

