

19940 25 12

Retention Latch Mechanism for the Wake Shield Facility

Timothy G. Vendrely*

ABSTRACT

The Wake Shield Facility (WSF) is a space transportation system (STS) payload that is scheduled for launch on STS-60 in November, 1993. It is being designed, tested and integrated into the STS by Space Industries Inc. for the University of Houston's Space Vacuum Epitaxy Center, a NASA Center for the Commercial Development of Space. The WSF is composed of two main components: a cross-bay carrier and a free-flying experimental platform. The WSF's primary objective is the epitaxial growth of thin films by controlled beam techniques in the ultra-high vacuum that exists in the wake of the free-flyer. The Retention Latch Mechanism (RLM) has been developed to act as the structural interface between the free-flyer and the carrier.

INTRODUCTION

Functionality, redundancy, reliability and cost were the driving factors in the design of the RLM. The RLM has three main functions: to connect the free-flyer to the carrier during ascent; to release the free-flyer for the experimentation portion of the mission; and then to re-attach the free-flyer to the carrier for the return to Earth. The WSF in its payload bay configuration is shown in Figure 1 and the free-flyer is shown in Figure 2. During all portions of the flight when the free-flyer is attached to the carrier, the RLM must be able to effectively transmit any loads encountered during flight from the free-flyer to the carrier. As a secondary function of the RLM is to ensure that the sensitive materials processed on the WSF are protected during ascent and during re-entry. This is accomplished by the RLM also providing a clamping force to an o-ring seal between the free-flyer and a sealed container in the carrier. The RLM must allow for unrestricted un-berthing and berthing procedures. Additionally it must be able to capture the free-flyer, given the operational tolerances of the Remote Manipulator System (RMS). The system must be reliable enough and redundant enough that the operation of the RLM can be accomplished without any Extra-Vehicular Activity (EVA). The RLM should be

* Space Industries, Inc., League City, TX

simple, using "off-the-shelf-technology" and proven materials to drive total costs down and to reduce the amount of testing required.

DESCRIPTION OF RETENTION LATCH MECHANISM

Developed to satisfy the design requirements of the WSF program, the RLM consists of two sets of four (4) over center latches that are mechanically connected through a linkage system to two dual drive electromechanical rotary actuators. Each set of latches has four (4) hooks that are driven in cam-slots near the interface ring between the free-flyer and the carrier. The primary latch hooks are spaced at 90 degrees from each other, while the second set of hooks is slightly offset from the first set. The RLM and associated hardware are shown in Figure 3. One set of four (4) latches and hooks is adequate to perform all of the requirements of the RLM; the other set is used in the event of a mechanical failure, providing a redundant feature. Once on orbit, the RLM is activated which causes the electromechanical actuators to unlock the latch mechanism and move the hooks out of the way so that the free-flyer can be deployed. When material processing is completed, the RMS positions the free-flyer within the capture envelope of RLM. As the RLM is activated, the actuators cause the hooks to move in their cam-slots which first center the free-flyer over the carrier then move the free-flyer into mating position. The RLM continues its motion until the latches lock the free-flyer in place. The position of the RLM is monitored by microswitch assemblies on the carrier and is controlled by crew members in the Orbiter.

The heart of the RLM are two dual drive electromechanical rotary actuators. Each actuator has two 3-phase, 110 volt motors that are driven differentially through a 5:1 reduction gear box. This allows for no loss in torque due to the loss of a motor; only the time for actuation is increased. The primary latch system's actuation time for both motors running is 1.17 minutes. For the secondary system, the actuation time is 1.02 minutes. If a motor were to not operate in either of the actuators, the actuation time would double for that actuator. These actuators, made by Honeywell, are flight proven having the same design been flown on SPARTAN. The rotary actuators translate their rotary motion into linear motion via two industrial precision ballscrew assemblies. The structure of the RLM has been designed so that the motors can be stalled with no adverse effects. A stalled actuator event would only happen if there were a failure of one of the RLM position sensing microswitch assemblies. The rotary actuators and ballscrew assemblies of the lower latch mechanism are shown in Figure 4.

As the actuators rotate and drive the ballscrew assemblies, their linear motion drives two unique aspects of the RLM. These

unique features are the over center pivot mechanisms, and the hooks and cam-slots. The ballscrews are mechanically connected through linkages to the over center pivot mechanisms and then also to the hooks in their cam-slots at the interface ring between the free-flyer and the carrier. These linkages, pivots, and hooks are the main load carrying members of the RLM. They are fabricated from 15-5PH stainless steel in the 1025 heat treat condition. The container in the carrier that serves as the support structure for the RLM is a welded structure fabricated from 304L stainless steel. A detail of the RLM linkages, pivot assembly and hooks is shown in Figure 5. When the free-flyer is attached to the carrier and the pivots are locked over center, any loads impacted to the hooks tend to drive the pivot farther over center. The loads are then dispersed into the support structure and will not travel down the linkages to the ballscrew assemblies and actuators. A close up of the pivot mechanism is shown in Figure 6. The hooks and cam-slots allow for sizable misalignment during berthing operations between the free-flyer and the carrier. The reach-then-grab action of the hooks results in a large capture envelope that is well within the positional tolerances of the RMS. The operational reach limits of the latch hooks are shown in Figure 7. Microswitch assemblies around the interface ring between the free-flyer and the carrier notify the crew if the free-flyer is within the latching envelope. The crew then activates the RLM and the hooks begin their motion in which they center the free-flyer then move it into position for mating. The hooks, linkages and pivots also are the mechanism by which an o-ring seal is compressed at the interface ring to provide a controlled environment for sensitive components on the free-flyer. A total force of 56.5 kN (12700 lb) is needed to compress the o-ring and provide an adequate seal. This translates to a preload in each hook-linkage-pivot system of 14.12 kN (3175 lb). The actual preload used during flight is 28.9 kN (6500 lb) per hook-linkage-pivot system, which prevents any gap occurring between the free-flyer and container during any flight loading condition due to deflections of the structure.

To ensure that the RLM meets all of the safety criteria for a safety critical system, all moving parts must have a redundant feature. To facilitate this, all rotating parts of the mechanism have two sliding surfaces so that the chances of a failure due to any one of the surfaces galling and siezing is reduced. Friction between sliding surfaces is reduced by coating all sliding and rotating surfaces with molybdenum disulfate solid film lubrication.

To minimize costs but still ensure safety, all of the fasteners used are commercially available, high strength military specification hardware. In highly loaded areas, the fasteners are high strength alloy steel, and in support areas,

the fasteners are 300 series stainless steel. All of the fasteners have full traceability and are subjected to the requirements stated in the JSC Fastener Testing Integrity Program.

Since the RLM is located in the environmentally harsh area of the Orbiter payload bay, environmental effects have played a key role in its design. However due to the mechanical nature of the RLM, the thermal/vacuum environment is the key design driver. All of the load carrying, rotating components and support structures of the RLM are fabricated from stainless steels. These steels minimize problems encountered due to thermal expansion or contraction because of their similar thermal expansion coefficients. The sealed container in the carrier, the attachment bell, is fabricated from stainless steel and provides a great thermal inertia which minimizes temperature gradients across the structure. Problems that may arise due to the vacuum, cold welding specifically, are eliminated by the rotating redundancy and friction reduction methods described above.

Another key component of the RLM are the microswitch assemblies that relay the position of the RLM to the crew in the Orbiter. These assemblies have to be effective, reliable, simple, and redundant. There are three different microswitch assemblies associated with the RLM: the ready-to-latch indicators, the latched indicators and the unlatched indicators. The first of these assemblies, the ready-to-latch indicators, are located around the interface ring between the free-flyer and the carrier. Each of the four locations have two microswitches in one assembly, offering dual redundancy. The assembly actuates the switches when the free-flyer is 25.4 mm (1.0 in) from the carrier in the four (4) locations of the assemblies. A close up of the ready-to-latch assembly is shown in Figure 8. The second microswitch assemblies are the latched indicators. These switches are located at the pivot assembly of the RLM. Each latch system has two microswitch assemblies and each assembly contains one microswitch for a total of four latched microswitches. The assembly activates the microswitch only when the pivot is in its over center position and locked in place. When the microswitch is activated, the circuit that carries power the drive motors in each actuator is broken. A detailed view of the latched microswitch indicator assembly is shown in Figure 9. The final microswitch assemblies are the unlatched indicators. These assemblies are located adjacent to the ballscrew assemblies. The switches are activated only when the latch hooks are at the end of their stroke and fully open. When the microswitches are activated by the assemblies, again the circuit that carries power to the motors is broken. Like the latched indicators, there are two microswitches per latch system, for a total of four (4) microswitches in the unlatched

indicator assemblies. A detailed view of the unlatched indicators is shown in Figure 10.

The design of the RLM was completed in accordance with the WSF program requirements for structural design. These requirements state that all load carrying elements will have a factor of safety of at least two on flight limit loads. Structural testing must then be completed at 140 percent of flight limit loads. Testing is then completed on the flight hardware to qualify the structure for flight loads. The RLM has successfully met the above requirements.

CONCLUSION

The RLM has been designed and developed expeditiously. The conceptual design was finalized in the fall of 1990 and detail design, fabrication, and assembly was completed just eight months later. To date, the entire structure of the WSF, including the RLM, has been through modal, acoustic and static structural testing at NASA's Johnson Space Center. The RLM has met or exceeded all of its planned objectives, and at the time of this writing, the WSF is undergoing final integration. Through proven mechanical design techniques and proper attention to the design criteria, an effective, reliable, redundant, safe and cost effective system has been developed in a short amount of time.

ACKNOWLEDGEMENTS

The author wishes to acknowledge that the success of the RLM is very much the result of a team effort. This includes the entire WSF team at Space Industries, Inc., the project leadership and support from SVEC, and the many individuals at NASA/JSC who have helped with the integration and testing of the WSF as a STS payload. The author also wishes to acknowledge Tom Bonner and Bill Creasy of Space Industries, Inc., the WSF's Project Manager and Project Director respectively, for their invaluable support, guidance and leadership during the development of the WSF. Without these two individuals, it is very unlikely that any of the demanding schedule, budget, or manpower constraints placed on the WSF would have been met.

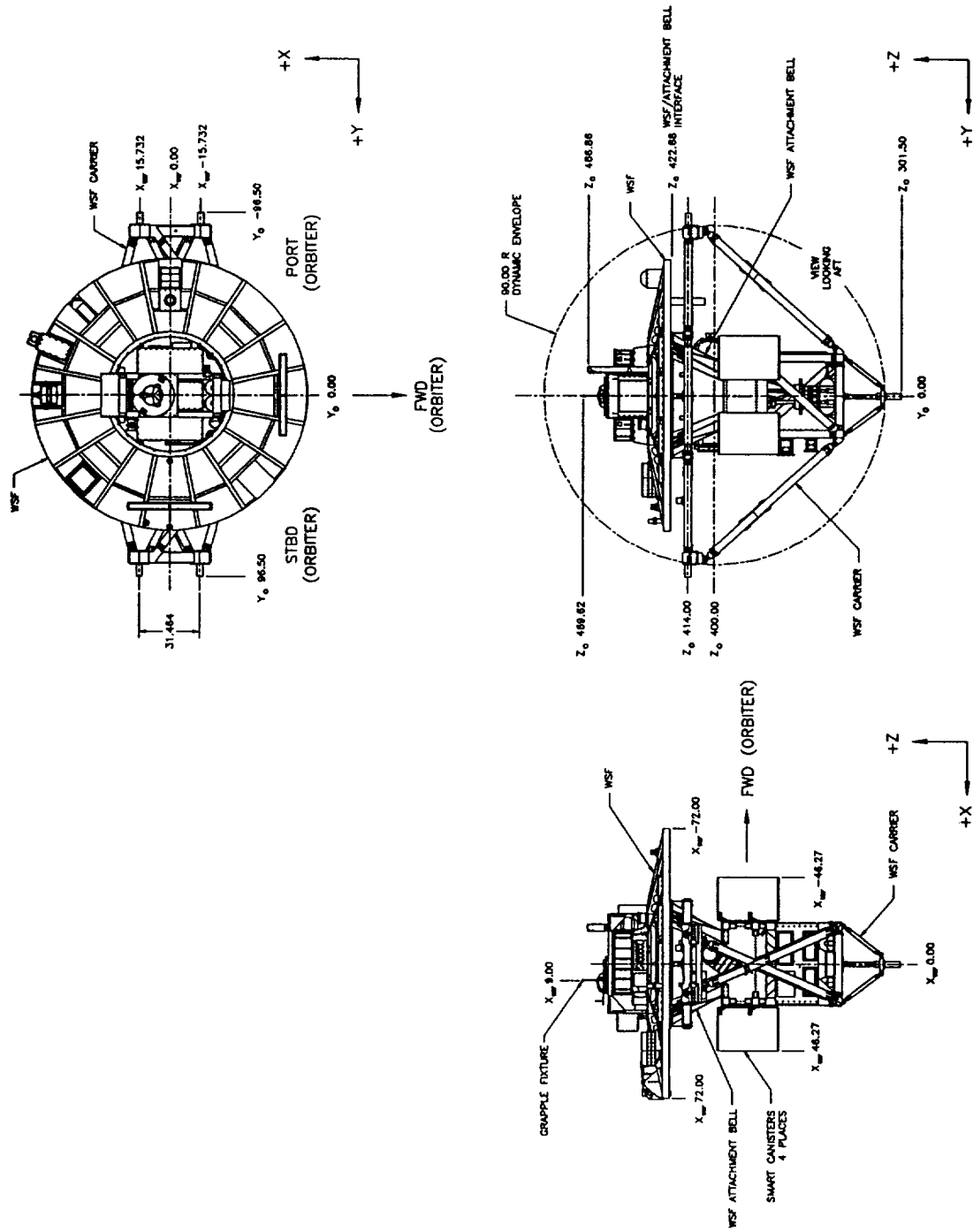

Figure 1. WSF Payload Bay Configuration 3-View

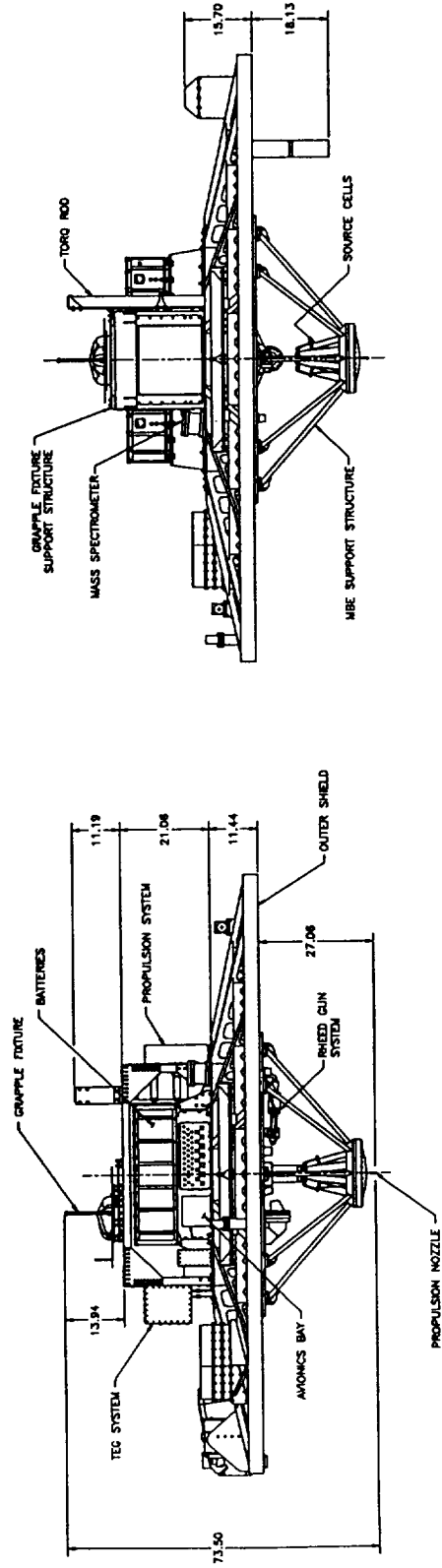
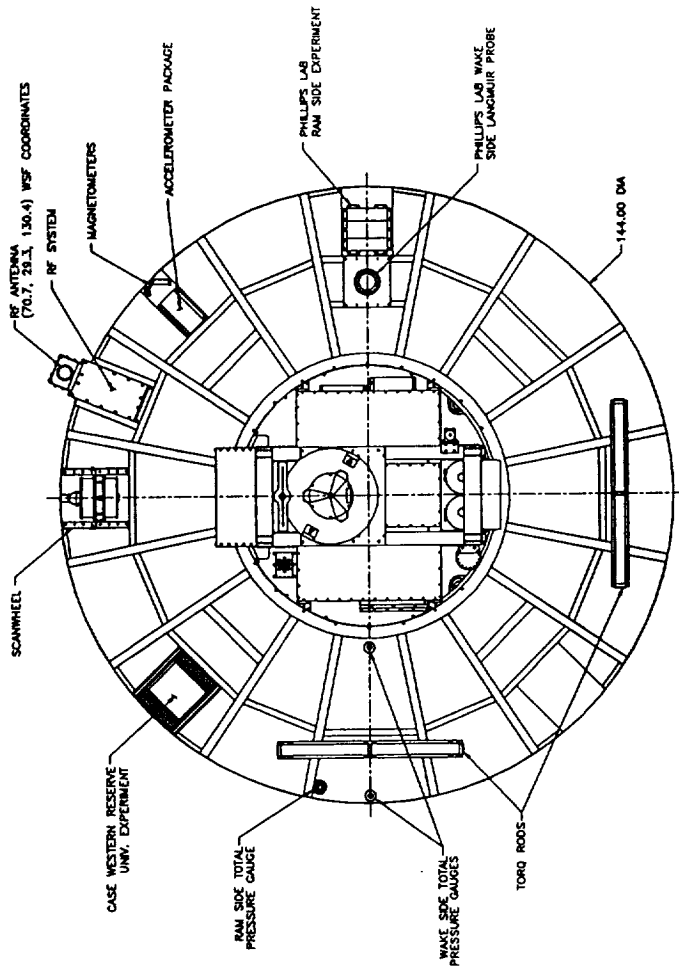

Figure 2. WSF Free-Flyer 3-View

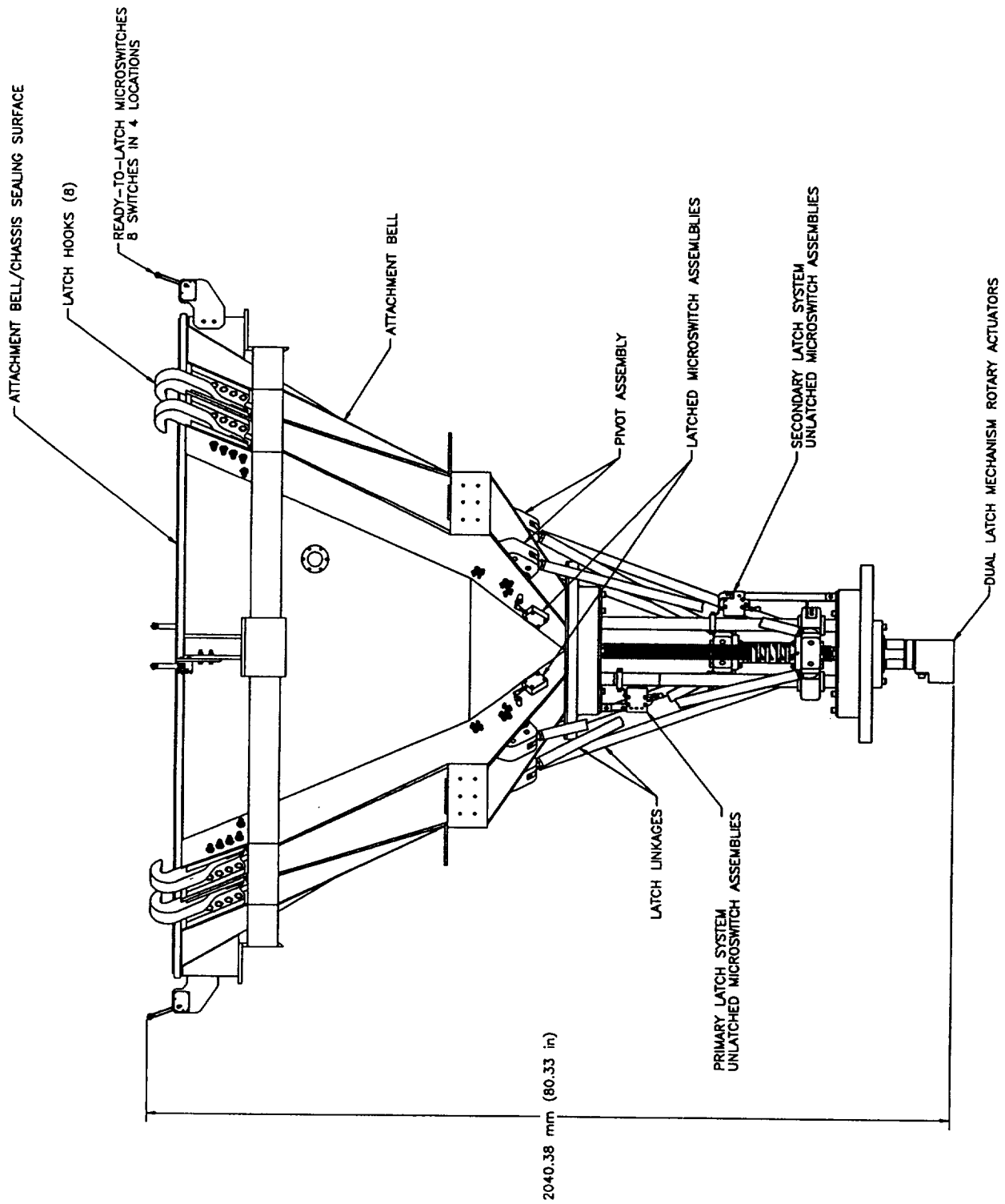

Figure 3. RLM System Components

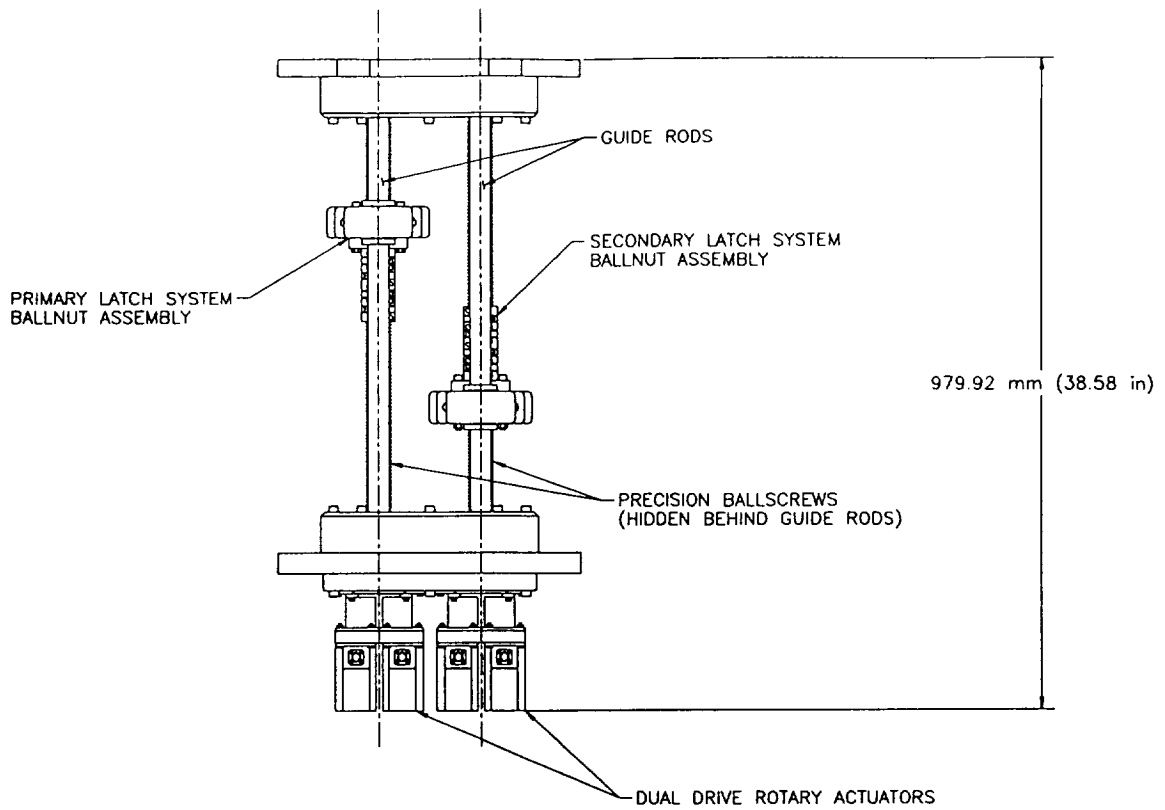

Figure 4. Lower RLM System Details

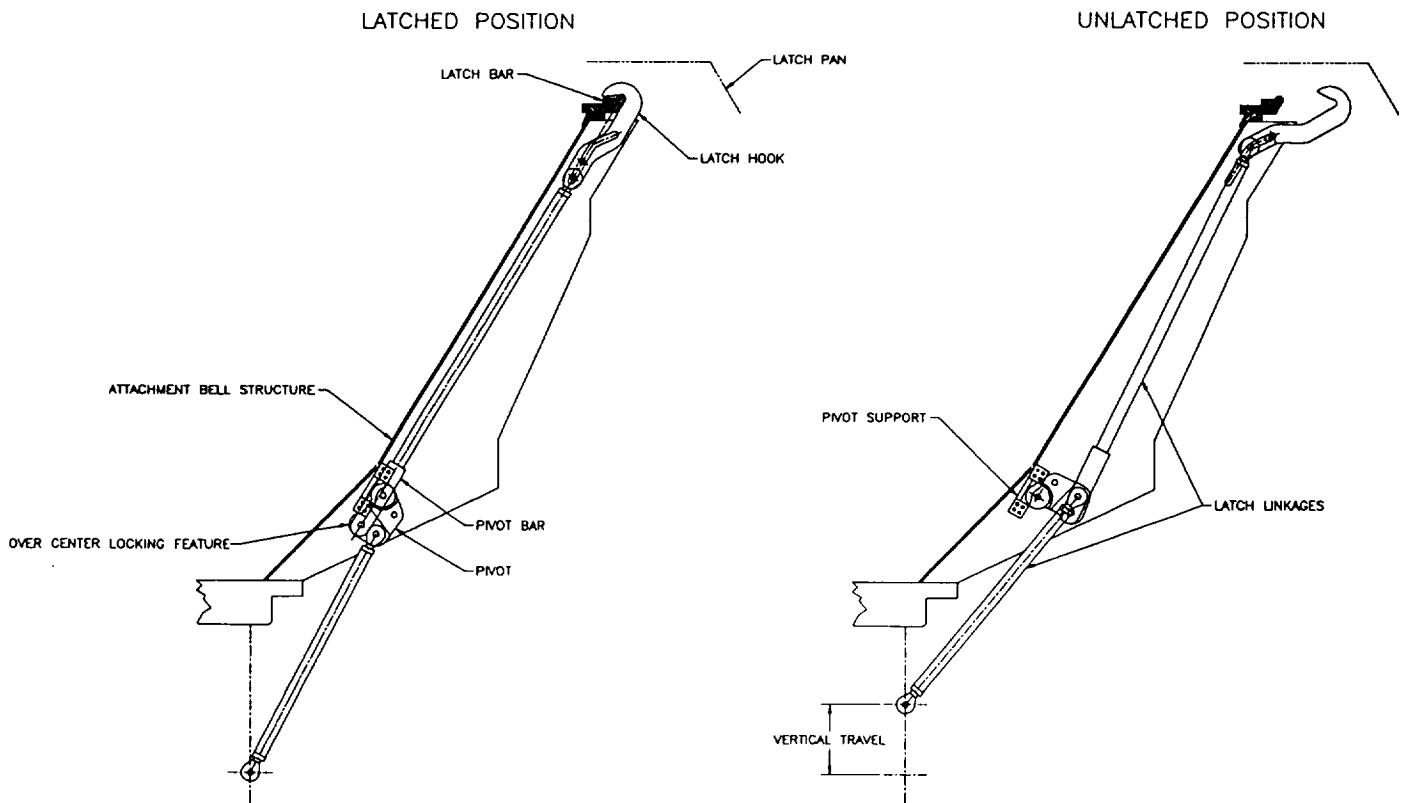

Figure 5. RLM Linkage, Pivot, and Hook Details

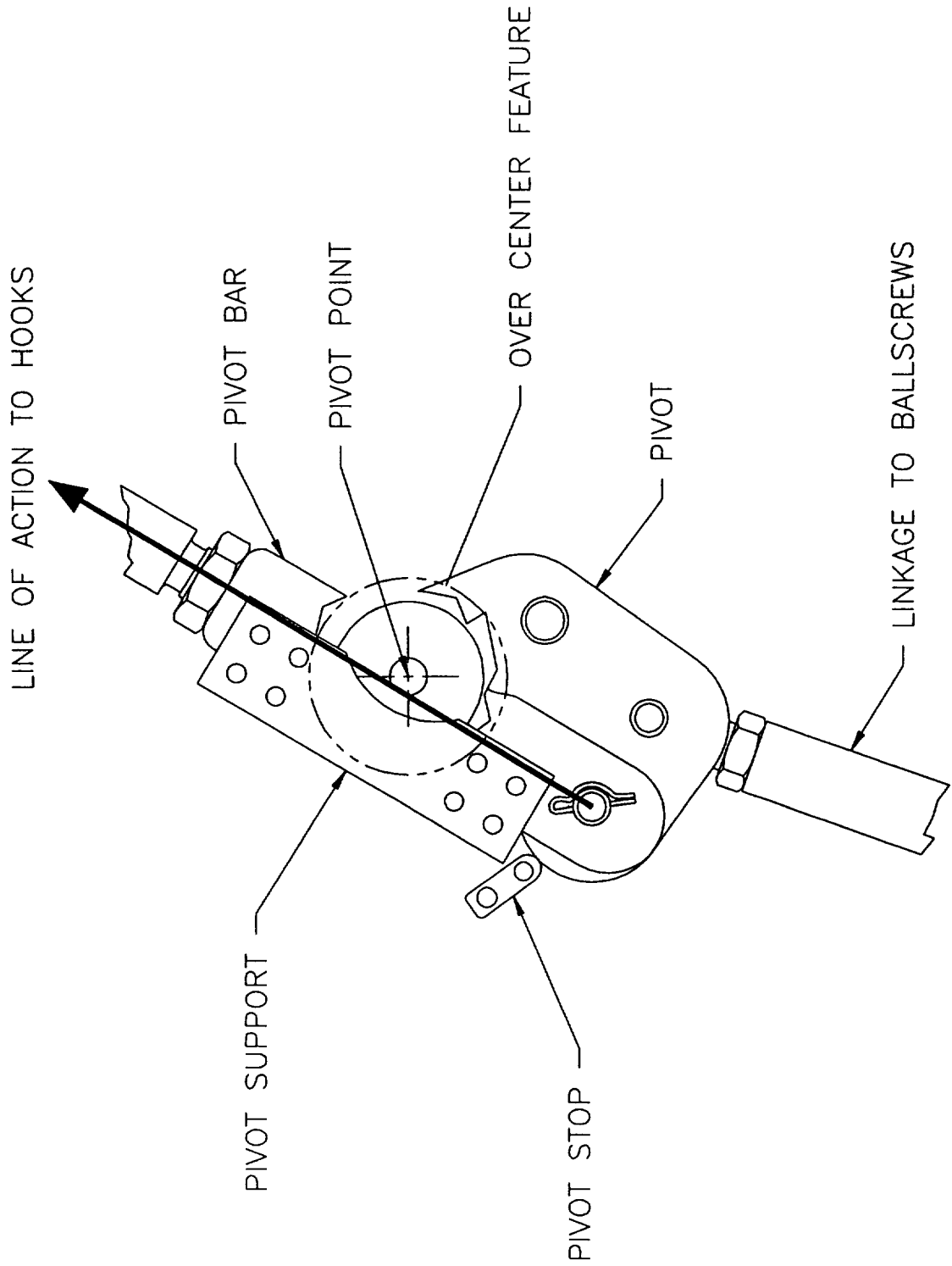

Figure 6. RLM Pivot Mechanism

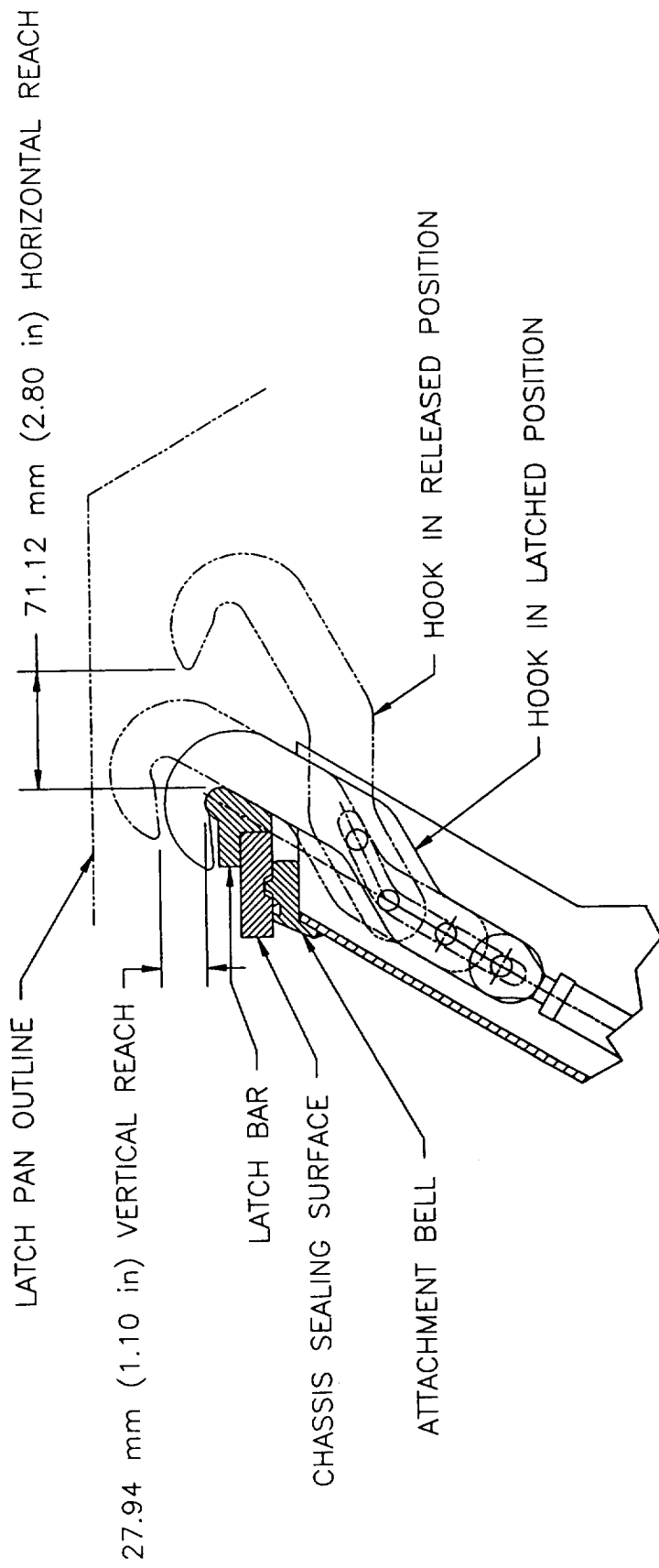

Figure 7. RLM Hook Reach Limits

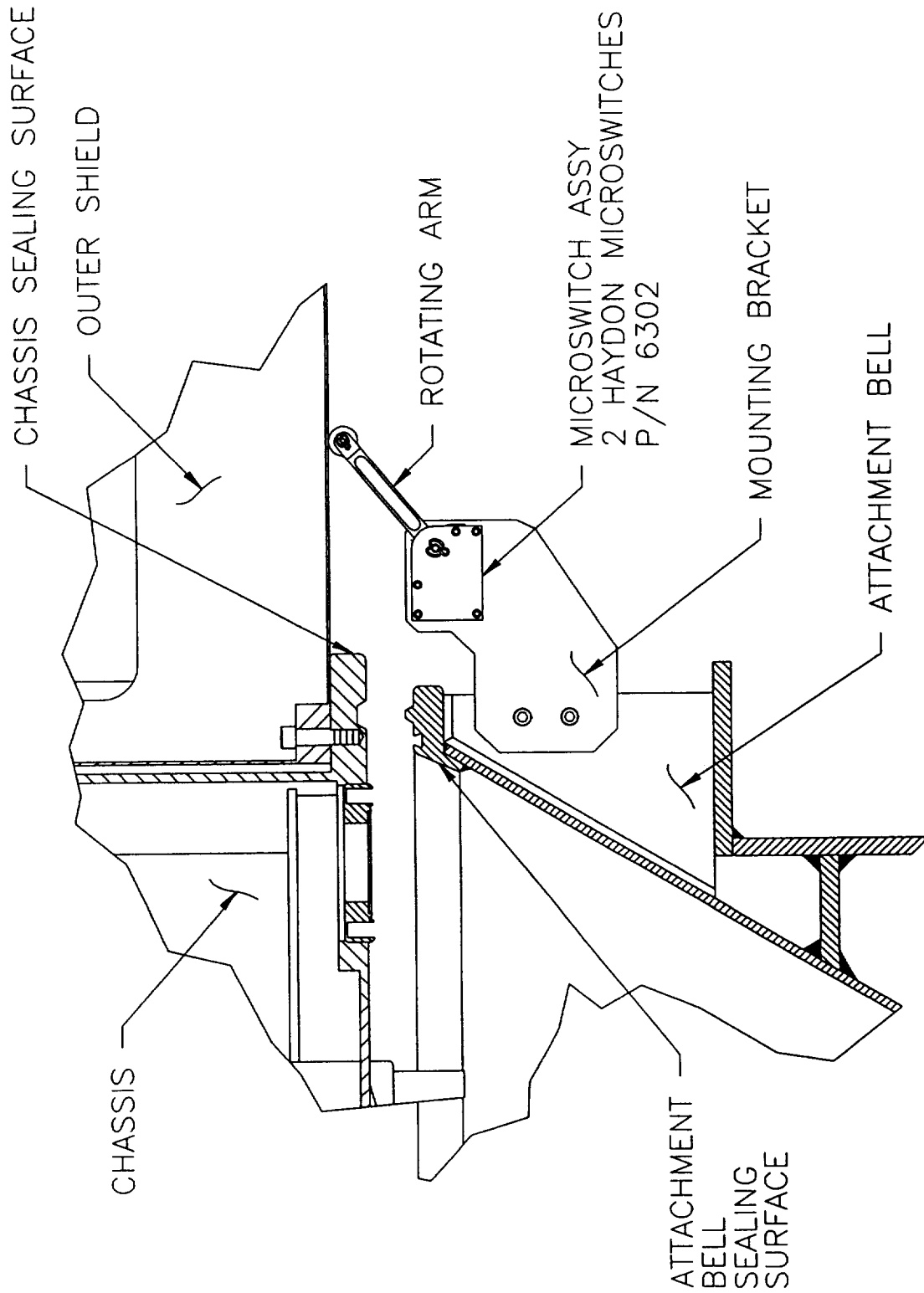

Figure 8. Ready-To-Latch Microswitch Installation

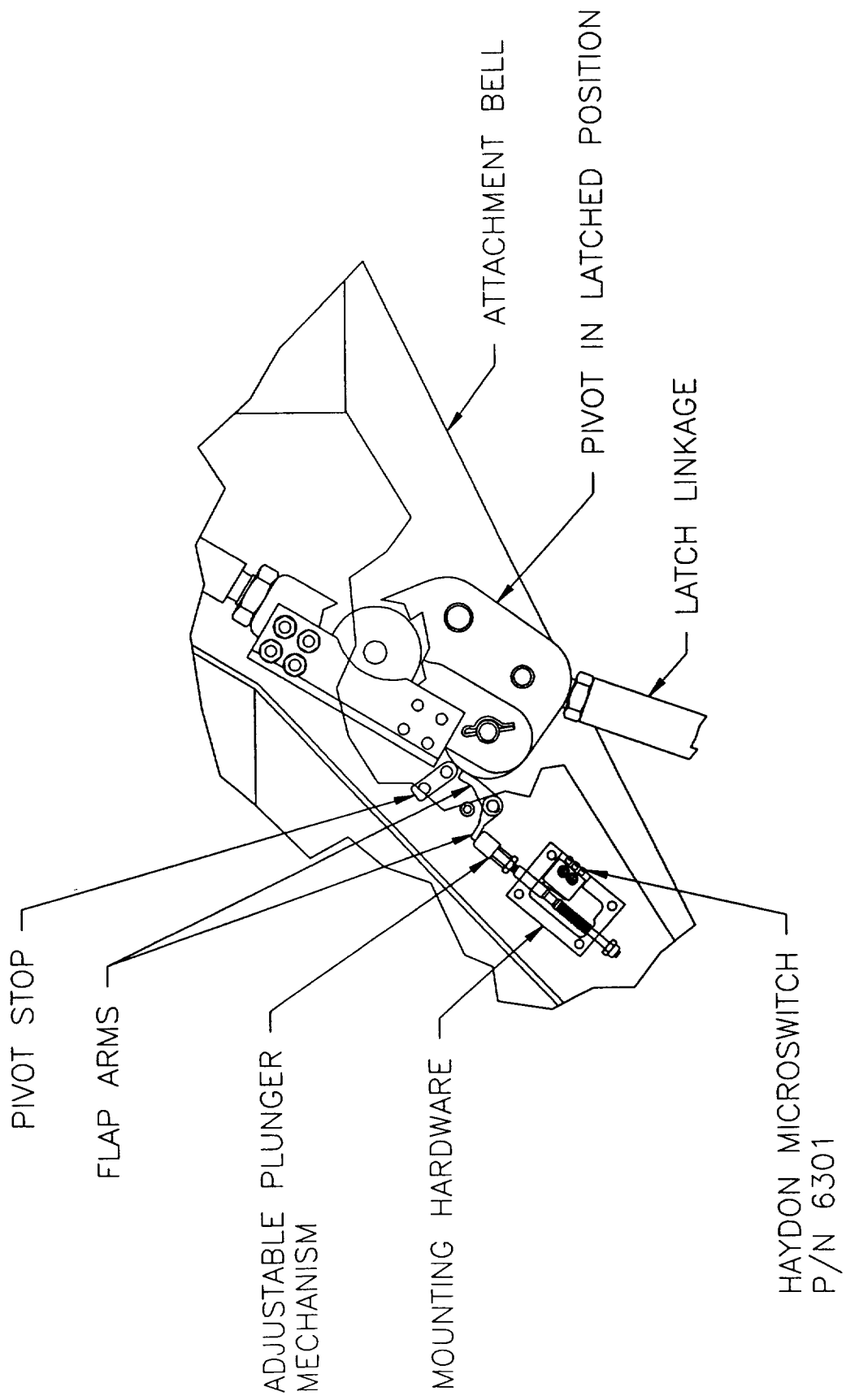

Figure 9. Latched Microswitch Installation

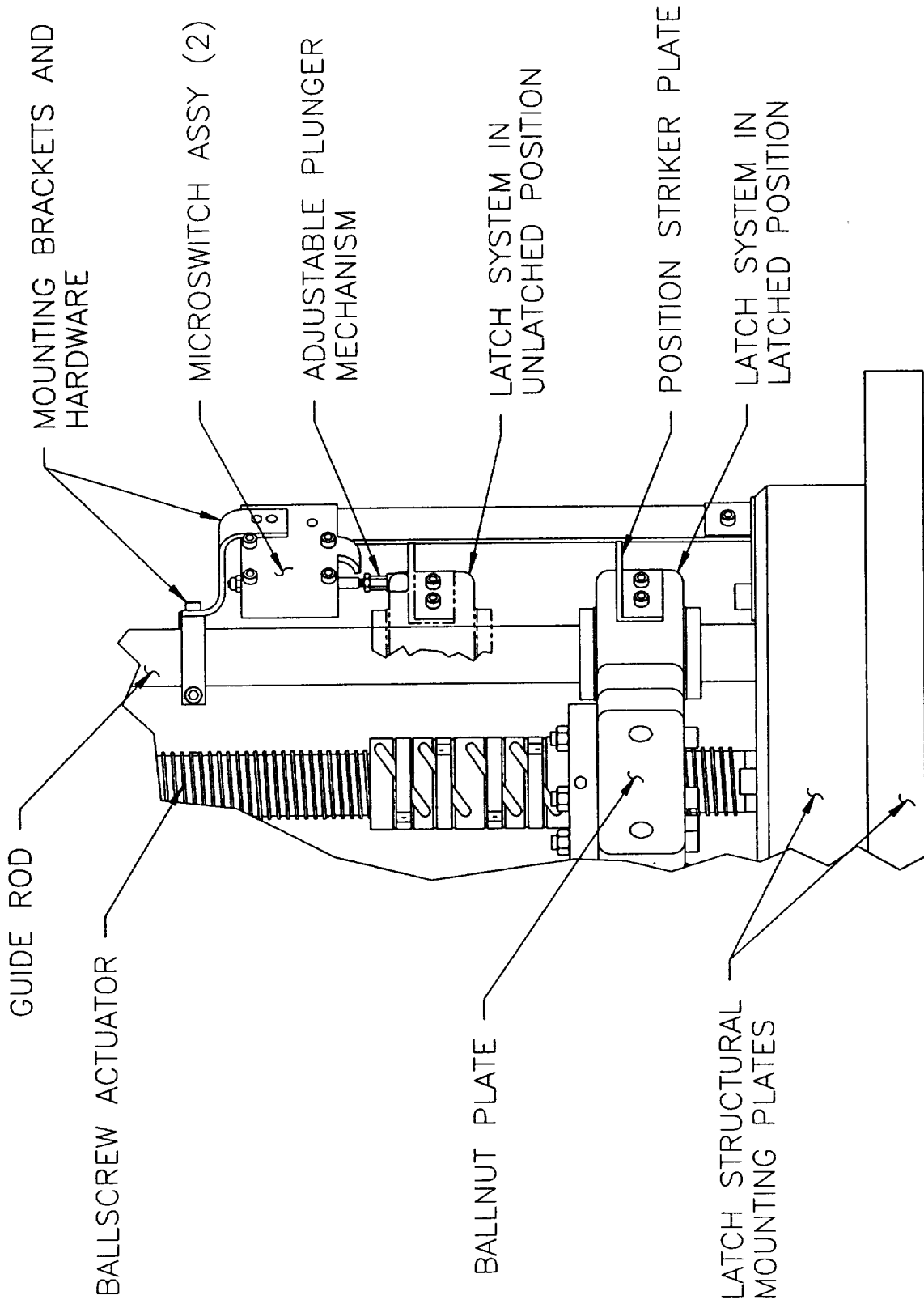

Figure 10. Unlatched Microswitch Installation