

1994025137

NSF 23040

## A GIMBALED LOW NOISE MOMENTUM WHEEL

U. Bichler & T. Eckardt \*

### Abstract

The bus actuators are the heart and at the same time the Achilles' heel of accurate spacecraft stabilization systems, because both their performance and their perturbations can have a deciding influence on the achievable pointing accuracy of the mission.

The main task of the attitude actuators, which are mostly wheels, is the generation of useful torques with sufficiently high bandwidth, resolution and accuracy. This is because the bandwidth of the whole attitude control loop and its disturbance rejection capability is dependent upon these factors. These useful torques shall be provided, without - as far as possible, parasitic noise like unbalance forces and torques and harmonics. This is because such variable frequency perturbations excite structural resonances which in turn disturb the operation of sensors and scientific instruments.

High accuracy spacecraft will further require bus actuators for the three linear degrees of freedom (DOF) to damp structural oscillations excited by various sources. These actuators have to cover the dynamic range of these disturbances. Another interesting feature, which is not necessarily related to low noise performance, is a gimbaling capability which enables, in a certain angular range, a three axis attitude control with only one wheel.

The herein presented *Teldix MWX*, a five degree of freedom Magnetic Bearing Momentum Wheel, incorporates all the above required features. It is ideally suited to support, as a gyroscopic actuator in the attitude control system, all High Pointing Accuracy and Vibration Sensitive space missions.

### 1. Introduction

Almost all spacecraft in orbit are equipped with ball bearing momentum or reaction wheels serving as actuators in the attitude control system. Among the various on-board system components, the wheels have been identified as one of the main source of vibration noise due to residual unbalances, bearing imperfections, etc.

Most approaches to overcome the vibration problem are either ineffective or cumbersome. A ball bearing wheel can be manufactured and balanced with higher and higher quality but this drives the cost to infinite while the relative improvements become asymptotically smaller and smaller. Putting a wheel on a passive isolator gives some improvements but such a device is bigger than the wheel itself. This introduces weakness and resonances and the direction of the

---

\*Teldix GmbH, Space Department, Bosch Telecom. Grenzhof Weg 36, 6900 Heidelberg, Germany.

momentum vector becomes uncertain. Moreover, the launch environment can degrade the mechanical quality of such systems. In the end, the vibration problem can only be avoided by the use of magnetic bearing wheels.

Magnetic bearing wheels have some general advantages such as higher speed, no mechanical contacts, no lubrication, no stiction etc. However, this alone is not such a significant reason to base a decision for the magnetic bearing, because the magnetic bearing's current disadvantage of more expensive electronics is at least counterbalancing.

The situation becomes entirely different with the MWX, where the following additional features are built in, which cannot be obtained with ball bearing wheels:

### **Low Noise**

The magnetic bearing position control loops are equipped with a highly effective Active Vibration Suppression control law with isolates unbalance vibrations of the wheel from the spacecraft. This noise isolation is so effective that virtually every visible noise effect has been completely switched off when the isolation system has been invoked.

The wheel's internal actuators are of the electrodynamic force generation type, which enables a high bandwidth, bi-directional and linear response to attitude control system (ACS) commands. This high bandwidth is not affected by the Active Vibration Suppression (AVS).

### **Control Moment Gyro Mode**

The momentum vector of the wheel can be tilted actively with respect to the spacecraft body ('vernier gimbaling'), which allows to use the wheel in a control moment gyro mode. This means that in addition to the one rotational DOF which is implemented by the motor torque control, the other two attitude DOFs can be adjusted by the tilting of the wheel. Thus, it enables three axis attitude control of the spacecraft in a fine pointing range with only one wheel and eliminates, compared to a fixed momentum wheel system, the need for a separate nutation damping device.

The vernier gimbaling is supported by a special gyro control law, which allows the wheel to be used just like three independent attitude actuators without suffering from disturbances caused by gyroscopic effects. The vernier gimbaling maneuvers require very little power. The tilting of the rotor may also be used to store cross momentum in order to compensate for a varying momentum of other rotating members on the satellite, like antenna pointing mechanism.

### **Active Damping of Structural Oscillations**

A magnetic bearing wheel has no mechanical contact between rotor and stator since there is a prescribed gap. Within this gap the rotor can be moved in all three translational directions (in addition to the above mentioned rotational directions) in order to generate reaction forces usable within an active damping system. This can be done with the full linearity, accuracy and high bandwidth of the electrodynamic force generation system. Moreover, in combination with

a side effect of the Low Noise control, it can even serve as a sensor for structural oscillations and can be extended to a stand alone damping device. Thus the wheel can be used further as a six DOF active damping device for flexible structures through fully controllable translational and rotational bearing forces - simultaneously with the main purpose of the wheel as three DOF attitude control actuator.

It shall not be forgotten to mention that the use of a magnetic bearing wheel permits the acceptance of a somewhat increased electronics complexity with inevitable impacts on mass, volume and reliability. A MWX is about 25% heavier than a ball bearing wheel of comparable size - however, this is an unfair comparison, since one MWX can substitute two or three ball bearing wheels.

Thus in the end the magnetic bearing solution can be very advantageous in an AOCS level trade-off and moreover due to the above mentioned unique features.

Possible applications are communication satellites, especially those with inclined orbit, satellites with optical communication links, micro-gravity missions, space telescopes and high resolution earth observation satellites. In long term manned space missions low noise wheels can reduce the effect of vibrations and the associated nerve-racking noise on the spacecraft environment and crew.

## **2. The Design of the MWX Wheel**

A cross section of the MWX is shown in Fig. 1. The design goals were

- >very low vibrational noise
- >vernier gimbaling capability
- >pancake profile
- >low weight, volume and power consumption
- >high reliability

### **General design characteristics**

The rotor is basically composed of a rim which is connected to a hub by a set of five spokes. Most of the mass is concentrated in the outer rim of the rotor contributing to the required moment of inertia.

The housing is divided into two compartments. The upper one contains the rotor and the signal processing electronics mainly consisting of sensors and controllers while in the lower one all the power electronics is accommodated.

Any deviation from the nominal rotor position is detected by a set of axial and radial position sensors and - using five control loops - balanced by forces generated in the actuators.

All five actively controlled degrees of freedom are of the electrodynamic (Lorentz) force generation type. This principle has many advantages with respect to controllability, low noise and the mass distribution between rotor and stator.

A brushless dc drive motor fits well to the magnetic bearing. An emergency bearing and a simple locking device complete the wheel.

## **Rotor rim**

The electrodynamic force generation type led to a m-shape cross section of the rotor rim as shown in principle in Fig. 2.

Also the spoke design is very important for the noise behaviour of the wheel, because mechanical deformations of the rotor rim would lead to a dramatically increased tilt sensor noise and have thus to be avoided. The optimization lead to specially shaped spokes which are very weak due to the rotor stretching caused by centrifugal forces or heating, while in case of any movement of the rotor rim relative to the central part of the rotor these spokes are extremely stiff.

The detailed design of the rim as well as of the spokes was carefully optimized by FEM analysis in order to ensure that the stresses in the spokes and the rotor rim will not exceed the limit of half the tensile strength. The maximum possible rotational speed of this rotor is more than 12000 rpm with a safety factor of 2.

## **Force generation systems**

The axial and tilt loop actuator elements are located in the outer slot of the rotor rim, see Fig. 2. The slot is equipped with permanent magnets which produce a circumferentially uniform magnetic field. Four epoxy embedded stator control coils, each of them covering nearly 90 ° of the circumference, are fitted into the slot. The current in each of these coils produces a force in axial direction. Applying equal currents to all 4 coils produces axial forces. Tilt torques are generated by exciting two opposite coils with opposite currents.

Since it is possible to generate the required forces and torques for the suspension by use of only three coils, sufficient redundancy is attained.

The radial bearings are located in the hub. A disk shaped coil system on the stator fits between two pole plates equipped with permanent magnets. Fig.3 shows the principal arrangement. Two opposite coils form the actuator for one radial DOF each.

The detailed design of the magnetic loops was optimized by three dimensional magnetic field computations with the goal, to get as much force as possible out of the system with the minimum thickness of the magnetic yokes.

## **Sensor System**

The eddy current principle was chosen, because it is simple, of low weight and reliable, provides high bandwidth and is sufficiently linear if both mechanics and electronics are designed appropriately. All sensors are of the differential type in order to minimize drift effects.

The long term stability was calculated to about 0.5% gain and offset error for 10 years operation in space environment. This is in any case fully sufficient, since the position sensor of the magnetic bearing wheel is always in an inner loop superimposed by the AOCS.

## Motor

The motor is of the brushless-dc type, which avoids magnetic cogging torque. The ironless three-phase, six-pulse design is featuring a high efficiency joined with an excellent torque controllability and assures minimum torque ripple. The wheel drive electronics incorporates a two quadrant converter and operates in either speed or torque control mode.

At low speed the wheel drive electronics receives the rotor position from a very simple eddy current sensor system and performs commutation switching. At higher speed (above 200 rpm) the commutation is derived from the electromotive force generated in the motor windings.

In case of a satellite power bus or main converter drop out, the motor is automatically switched into a generator mode to maintain the stable suspension down to about 1500 rpm when the electromotive force becomes too low to deliver enough power to supply the electronics.

## Emergency bearing

The task of the emergency bearing is to provide a non-disturbing landing and a smooth run-down exhibiting minimum noise figures in case of a failure in the suspension electronics. It consists of two ball bearings, which are located inside the hub of the rotor. As a ball bearing lifetime of only 100 hours (about 200 run downs) is sufficient (only used in case of power drop outs at less than 1500 rpm or when a fatal failure occurs) there are only low demands to these bearings. Tests performed with gravity compensation have shown, that the emergency bearing operation is safe and uncritical. The rotor runs down with only little wobbling.

## Locking mechanism

A locking mechanism with re-lock capability keeps the rotor in a safe mid-gap position during launch. The system, as shown in principle in Fig. 4, consists of two tubes of a special space proven rubber. It is closed before launch by inflating the tubes with compressed gas and released in space by a redundant set of magnet valves.

The locking system is reusable, thus the wheel can be tested after transportation and assembly into the satellite and even in the rocket short before launch.

## Technical Data (EM)

Diameter .....	343	mm
Height .....	105	mm
Total Mass (incl. electronics) .....	11.8	kg
Nominal Speed .....	± 6000...10000	rpm
Angular Momentum .....	63 ... 105	Nms
Gimballing Torque (around x and y axes)....	± 3.9	Nm
Gimballing Angle .....	± 1.7	°
Slew Rate Capability .....	± 3.5	°/sec
Cross Angular Momentum (6000 rpm).....	± 1.86	Nms
Motor Torque .....	± 0.15	Nm

Power Consumption (steady state, 6000 rpm)...	14	W
Force Noise .....	< 0.01	N
Torque Noise .....	< 0.01	Nm
Angular Rate Tolerance x,y axis .....	3.5	°/s
Acceleration Tolerance z-axis .....	9.8	m/s <sup>2</sup>
Acceleration Tolerance x,y-axis .....	2.2	m/s <sup>2</sup>
Limits without leaving AVS (1)		
Angular Rate Tolerance x,y axis .....	0.17	°/s
Acceleration Tolerance z-axis .....	0.5	m/s <sup>2</sup>
Acceleration Tolerance x,y-axis .....	0.1	m/s <sup>2</sup>
Reliability 10 years, non redundant .....	0.89	
Self Suspension Time at power drop out (2)	1200	s

(1) Limit can be overcome by active counterbalancing

(2) 0g condition.

### 3. Vernier Gimballing

The rotor and thus the momentum vector can be tilted actively within a range of about  $\pm 1.7^\circ$ . A special tilt control law assures, that the tilt responses are not deteriorated by gyroscopic effects, *i.e.* a tilting in one direction is decoupled from the orthogonal direction. This is achieved by an overcompensated gyro-decoupling, which is essential to assure the tilt loop stability with large margins in view of parameter degradations.

The effect is demonstrated by the step responses shown in Fig. 5. Steps have been applied to one of the tilt axes and the responses of both have been measured at 6000 rpm. In the left column it can be seen, that with a simple uncoupled tilt control law the quality of the desired response is deteriorated and even the uninvolved axis becomes disturbed due to the gyroscopic effect. In the right column, the more sophisticated control law of the MWX has been applied which removes all these disturbing effects. It is easy imaginable, that such a behaviour is much better suited for spacecraft attitude control purposes.

It is a special feature of the MWX-X, that it is possible to exert gyro control torques for the attitude control of the S/C while the produced noise of the wheel is still low.

### 4. Isolation of Wheel Vibrations

Although there is no contact between rotor and stator, magnetic bearing wheels exhibit nearly the same magnitude of perturbations as ball bearing wheels unless special provisions are made to suppress this noise. The sources of the unwanted disturbing forces and torques are:

1. Imbalance, which means that the axis of the position sensors measurement surface is radially shifted (-> static imbalance) or/and tilted (-> dynamic imbalance) against the axis of inertia.
2. Mechanical imperfections of the rotating parts as irregularities in a sensor surface, a pole piece or a permanent magnetic field.
3. Poorly damped bearing control loops, for example due to passive nature, nonlinearities, structural modes or coupling effects between the different loops.
4. Poorly damped gyroscopic oscillations as nutational and precessional motions, which means a whirling motion of the spin axis around the angular momentum vector.

All this results in an unwanted movement of the rotor surface within the stator. If there is the typical force generating system which transforms gap variations into force and additionally a control system which tries to keep the gap constant then the same noise is produced as in a ball bearing wheel.

A simple suspension loop model, shown in Fig. 6, is used to introduce and discuss AVS, active vibration suppression.

The origin of all the noise is the gap variation, which can be found in the model as the center of gravity (CG)-position modified by the various gap disturbance sources mentioned above.

If there is a gap-force coupling in the bearing, the synchronous forces are produced in the bearing directly out of the gap variations before it is possible to filter them out. This is true for all electromagnetic force generation principles, where a change of the gap causes a change of the (bias or permanent) flux and thus of the force. Because of this the MWX is equipped with the electrodynamic bearing principle, where the generated force is independent of the relative position and the relative motion of rotor and stator.

The other noise path is the control loop itself and AVS means, that the sensor disturbances must be filtered out before reaching the power amplifier and becoming force or torque. The AVS method used in the MWX is the 'model following control'.

The principle idea of the model following control is to use the output of an observer for the control feedback instead of the disturbed position sensor signal. Fig. 7 shows the principle block diagram of the control loop with observer, which is fed with the force acting on the rotor.

To prevent the observer from long term drift effects, the low pass filtered difference between the real position signal and the model position is used to correct the observers state variables. Here the difference becomes evident: normally, the sensor output with it's noise is connected directly to the (differential!) controller, now there are a low pass filter and the observer in between. Thus from the real sensor signal only the lowest (near dc) frequency components are used. (Because of this, special care has to be taken with regard to control loop stability at these frequencies!) The noise contributors however are of the wheel's rotational frequency and harmonics thereof, thus of comparably high frequency. They are filtered out by a 4 1/2 order low pass filter. This is the reason why the noise suppression becomes effective at speeds say above 1000 rpm and is then further getting better and better.

The difference of the real position and the observer position is fed through a low pass filter to achieve the long term compensation of drift effects. To control faster externally impressed stator movements, for example when the satellite fires a thruster, this difference is additionally fed to a limit switch, which for example detects if the difference exceeds half of the gap. If so, it uses a second, stronger feedback to force the observer position immediately to the real position and, with this, the suspension loop can react and prevent a touch down of the rotor. During the activity of the limit switch, the low noise quality is of course reduced, but there is no low noise condition during an external disturbance anyway. When the external disturbance is over, the wheel automatically enters low noise condition again.

It can be further seen from Fig. 7, that the active spacecraft actuation is not influenced by the MFC, because the path from the position command to the (desired) force or torque remains unchanged.

Some results achieved with the real wheel equipped with MFC in all 5 magnetically suspended axes are shown in the next figures. In Fig. 8, the force  $F_x$  in radial  $x$ -direction, the force  $F_z$  in axial-direction and the torque  $T_x$  around the  $x$ -axis that are induced into the wheels mounting base, *i.e.* the satellite, are shown at a speed of 6000 rpm. (The forces and torques were measured with a six DOF dynamometer.) First, on the left hand side of the figure, the wheel is controlled by the conventional proportional-differential law of magnetic bearings, where there is practically no difference to a ball bearing wheel. On the right hand side, the wheel is controlled by the MFC low noise control system. It can be seen, that almost all the noise is removed.

In Fig. 9, the same is shown as Fourier plots, now for all five forces and torques (the sixth torque is that around the spin axis, *i.e.* the motor torque, which is not affected by AVS.) The synchronous component and the harmonics can be clearly seen at  $n \cdot 100$  Hz ( $n = 1..5$ ) in the conventionally controlled case (left), but hardly with the MFC (right).

Another view of the low noise behaviour is given in Fig. 10. The torque noise fundamental and the 1<sup>st</sup> and 2<sup>nd</sup> harmonics are plotted vs. speed. In the fundamental, the typical MWX noise suppression which increases with speed is clearly seen. The harmonics show a more undetermined behaviour, which is due to some parasitic resonances in the BB set-up. Theoretically, the harmonics should become suppressed almost like the fundamental, and with the EM wheel improvements are expected in this regard. However, the harmonics are already small and need not to be suppressed by the same factors like the fundamental.

The absolute noise values shown in the figures 8, 9 and 10 are not yet the achievable limit, since the wheel was a poorly balanced laboratory bread board model. The only goal was to demonstrate the relative attenuation of the produced noise - which is even now 100 .. 1000 times lower than with a ball bearing wheel of comparable or even smaller size. This was proven in a comparing investigation of the european space agency (ESTEC) /2/.

However, later, in space, it will be a high quality wheel, well balanced, with high circular uniformity of the magnetic field. Then the basic noise will be even more lower and the suppression will further attenuate it.

## 6. Active and Passive Damping Forces and Torques

The wheel can be moved freely within the mechanical gap of the emergency bearings, because all DOFs are actively controlled. Thus forces and torques can be generated by accelerating and decelerating the rotor.

These forces can be used to damp oscillations of antennas, solar arrays or large structures, *i.e.* the wheel with it's translational or even tilt axes can perform on the side the task of an actuator within an active damping loop without any degradation of the wheels performance.



The left side of Fig. 11 shows a test measurement with the MWX with a movement of  $\pm 0.1$  mm of the rotor in axial direction ( $\pm 0.6$  are possible) that causes a force of  $\pm 2$  N at 10 Hz. The maximum forces that can be generated are functions of the frequency and the gap. These maximum forces are computed for the MWX and shown in the right side of Fig. 11.

Another damping effect results passively from the bearing control loops. The wheel, in its low noise mode, is coupled to the stator only for very low frequencies up to about 4 Hz, but with a very good damping factor. This is illustrated by Fig. 12. Thus the wheel behaves like a passive damper below this corner frequency in addition to its active damping capability at all frequencies. There is no such coupling between the rotor and the satellite for higher frequencies.

Moreover, structural oscillations can be measured by the MWX, for all higher frequencies up to the wheel speed, since stator movements are not followed by the rotor and can therefore be seen in the signals of the 3 translational and 2 rotational position sensors. Thus the wheel, as is, without any increased complexity and without any degradation of its main purpose, can serve as both a sensor and damping actuator for structural oscillations up to some hundreds of Hz.

## **7. Applications of the MWX**

### **The MWX in a Mechanical Double Gimbal System**

If the MWX with its low noise three axis attitude control capabilities is utilized, the small gimbaling range (compared to mechanical gimbal systems) may be an unwanted limitation. A possible solution would be to mount the MWX into a mechanical double gimbal system. Then the large angular attitude maneuvers can be performed with the gimbals (the MWX with its tilt torque capability of some Nm has no problem with this). Thereafter, the gimbals can be locked in position and then the MWX resumes fine position control at low noise condition during the mission performance period.

The only disadvantage would be, that the spin axis will not necessarily point to the target any more and two axis pointing like with a telescope would additionally require reaction torques from the drive motor. However, in a low noise wheel there will always be a low noise motor present. Just the motor torque will be substantially lower than the gimbal torques and require more power.

### **Two MWX Substitute a Skewed Arrangement of Reaction Wheels**

An interesting proposal is the use of two vernier gimballed wheels running in opposite direction to produce a net momentum in any desired direction by tilting one or both wheels and spinning them up and down, respectively. By doing this it is possible to align the satellite in every desired direction in space by tilting the overall momentum of the satellite, which is stored in the wheels. The principle idea is shown in Fig. 13.

The advantages are that very little power is required for the maneuvers, since the vernier gimbaling needs in principle little power. Also the drive motors would be used only in differential mode, i.e. the braking energy of one wheel would supply the other accelerating

wheel. The main advantage over a reaction wheel system and thus the main purpose of such a system is, of course, still the low noise performance.

### **The MWX in a communication satellite with inclined orbit**

The inclined geostationary orbit is said to be a solution towards extended satellite lifetime by fuel-savings through less station-keeping. The angle of this inclined orbit will be about  $5^\circ$ . This angle is also considered as the limit for a future extension of the vernier gimbaling capability of the MWX. Thus, a MWX can serve as momentum wheel for such a satellite, providing not only a constant attitude stabilization and compensation of cyclic torques through cross momentum storage but, at the same time, the periodic attitude maneuver in order to point constantly at the same location on earth during all the orbit.

### **Summary**

The MWX provides a free-of-mechanical-contact momentum vector inside the spacecraft and allows to exert forces and torques in all directions between this vector and the spacecraft such, that a vibrationless 3-axis attitude control in conjunction with 6-axis active damping of structural oscillations results.

The special features of the wheel are:

- Low vibrational noise, about a factor of some 100 or more lower than of a ball bearing wheel of comparable or even smaller size
- Vernier Gimbaling up to  $\pm 1.7$  (later  $3^\circ \dots 5^\circ$ ) with a gyro-disturbance removing control law, practically 'without' additional power, enabling:
  - 1) Two- or three axis attitude control in a fine angular range at low noise conditions
  - 2) The inherently linear, high bandwidth and very strong gimbal torques are ideal for fast, high quality attitude control and disturbance rejection at the same time
  - 3) Cross momentum storage capability;
  - 4) Nutation damping
- Active damping of structural oscillations, passive damping of structural oscillations, sensing of structural oscillations.

All these features have been tested at the real BB wheel and all results presented in this paper are real measurements, no simulations.

The gimbaling range can be extended to about  $3^\circ \dots 5^\circ$  from our present point of view without principal problems. The size of the wheel is not limited at all, just smaller ones cannot accommodate all the electronics and would require a separate box.

Although the theory of the MWX looks comparably adventurous, the technical realization is very safe and reliable. The mechanical elements are rugged, thanks to the launch vibrations lock out device, without any degradation and have the unlimited life. The electronics are not critical and the reliability is proven predictable. Finally the control law has been designed to be very robust with respect to parameter variations over time.

Thus an AOCS, build around this wheel, can be considered as a real and interesting alternative since it offers and combines different features not obtainable with ball bearing wheels. It can even be advantageous in terms of weight, volume and reliability, when the comparison is not performed wheel by wheel but on AOCS level.

For high accuracy missions, it may be the only possible solution in the end.

### Acknowledgements

The development of the magnetic bearing momentum wheel MWX is jointly funded by Teldix and the European Space Agency (ESA).

### References

1. Auer, W., "Ball Bearing Versus Magnetic Bearing Reaction and Momentum Wheels as Momentum Actuators." *AIAA Global Technology 2000*, Baltimore 1980.
2. ESTEC, BAe, Aerospatiale, Teldix, "Very High Pointing Accuracy AOCS Study". Study part 'Noise measurements of wheels'.

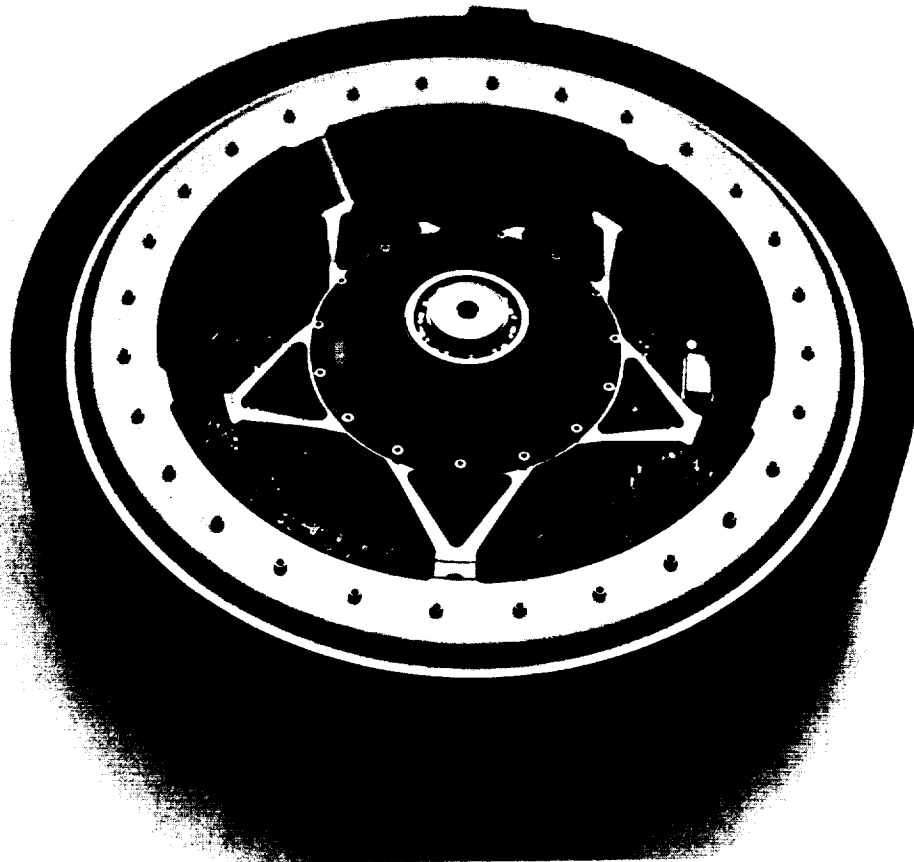

*The MWX EM Wheel*

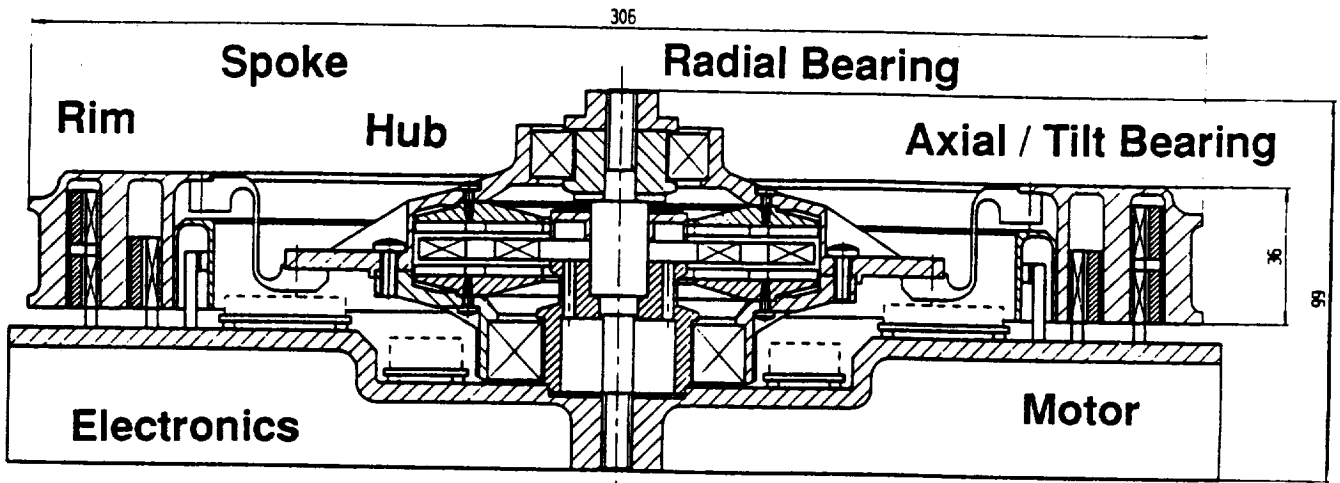

Fig. 1 Teldix 5-d.o.f. electrodynamic bearing wheel MW-X (EM)

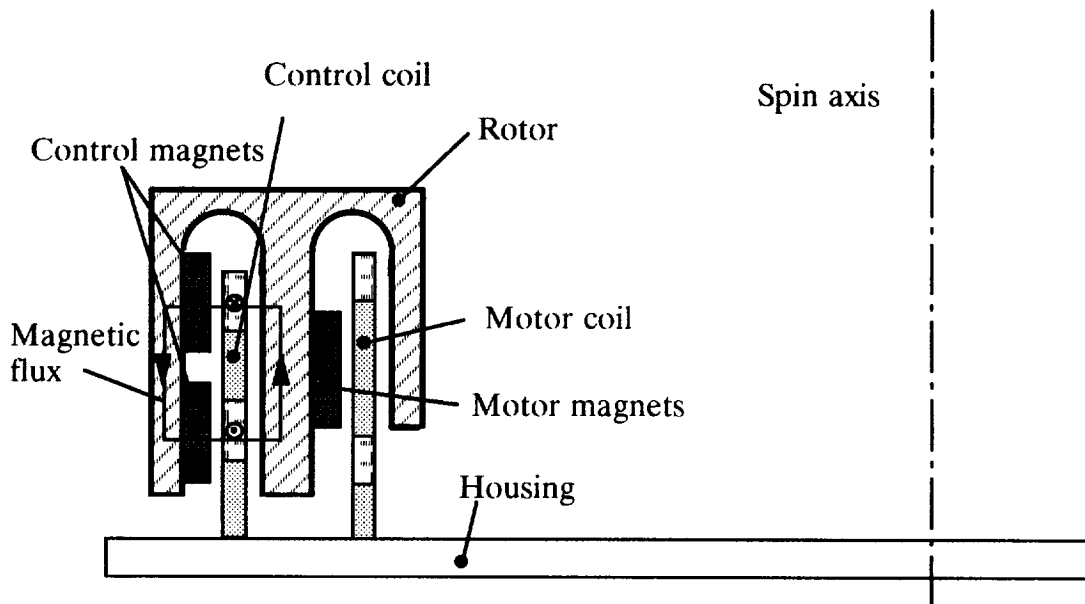

Fig. 2 Axial Force and Tilt Torque Generation

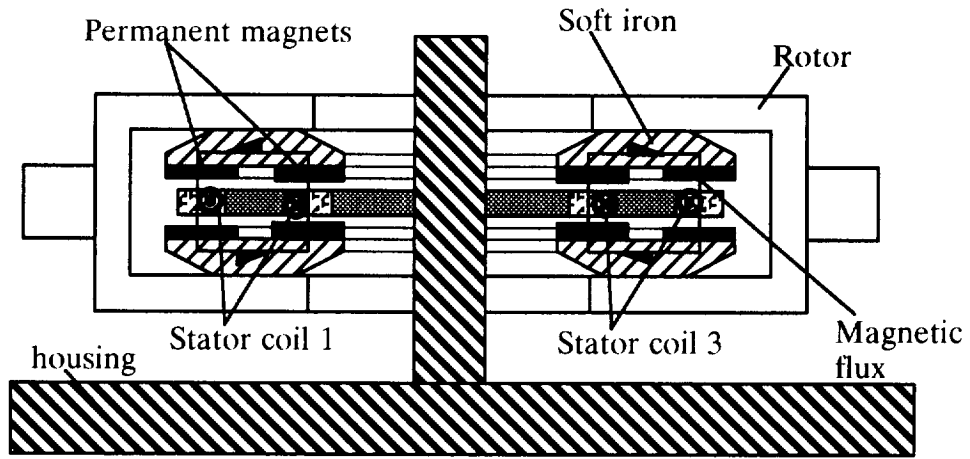

Fig. 3 Radial Force Generation

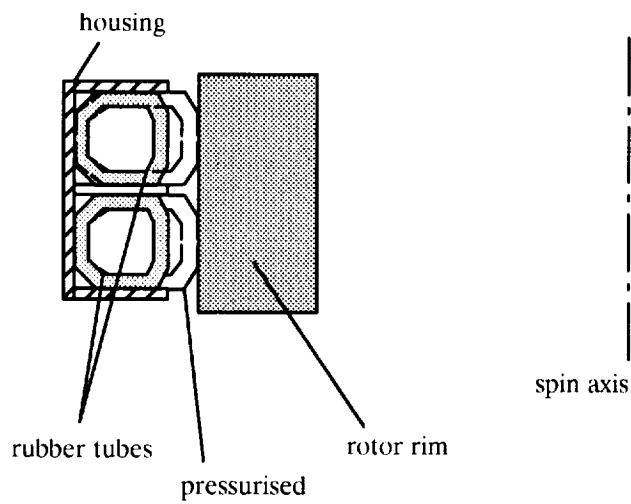

Fig. 4 Locking system

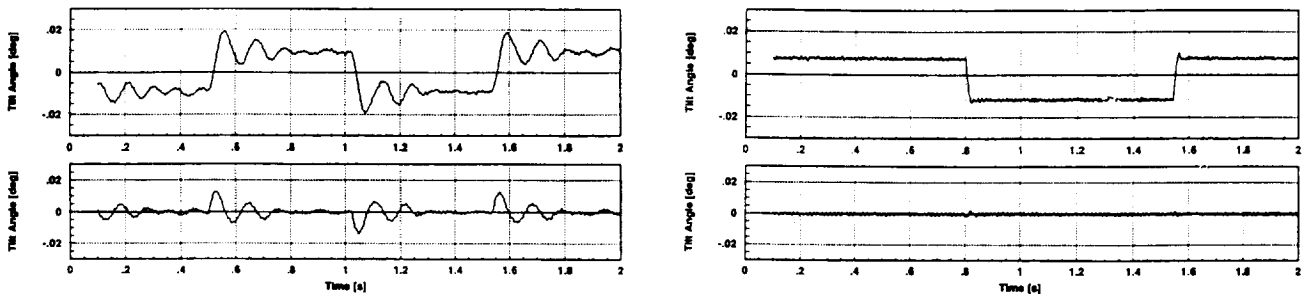

Fig. 5 Tilt Step Responses  
with and without Vernier Gimbaling Control

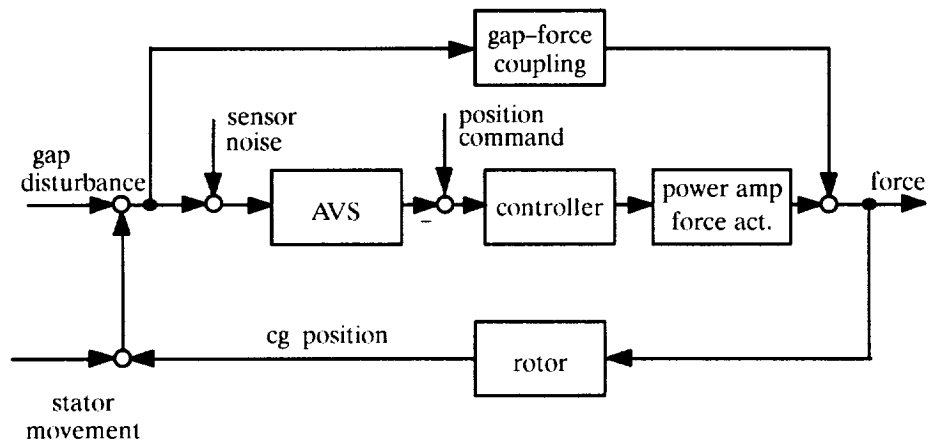

Fig. 6 Simple suspension loop model

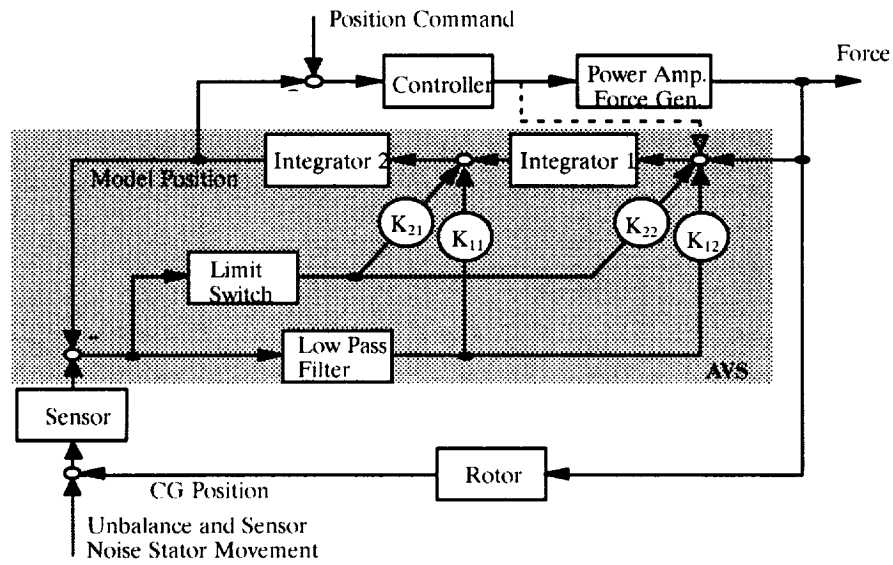

Fig. 7 Model Following Control

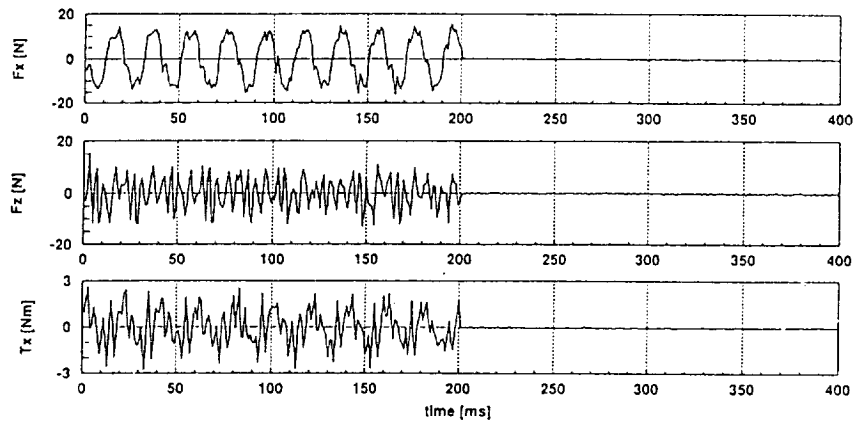

Fig. 8 Wheel Force and Torque at 6000 rpm (time domain) with conventional (left) and MFC controllers (right).

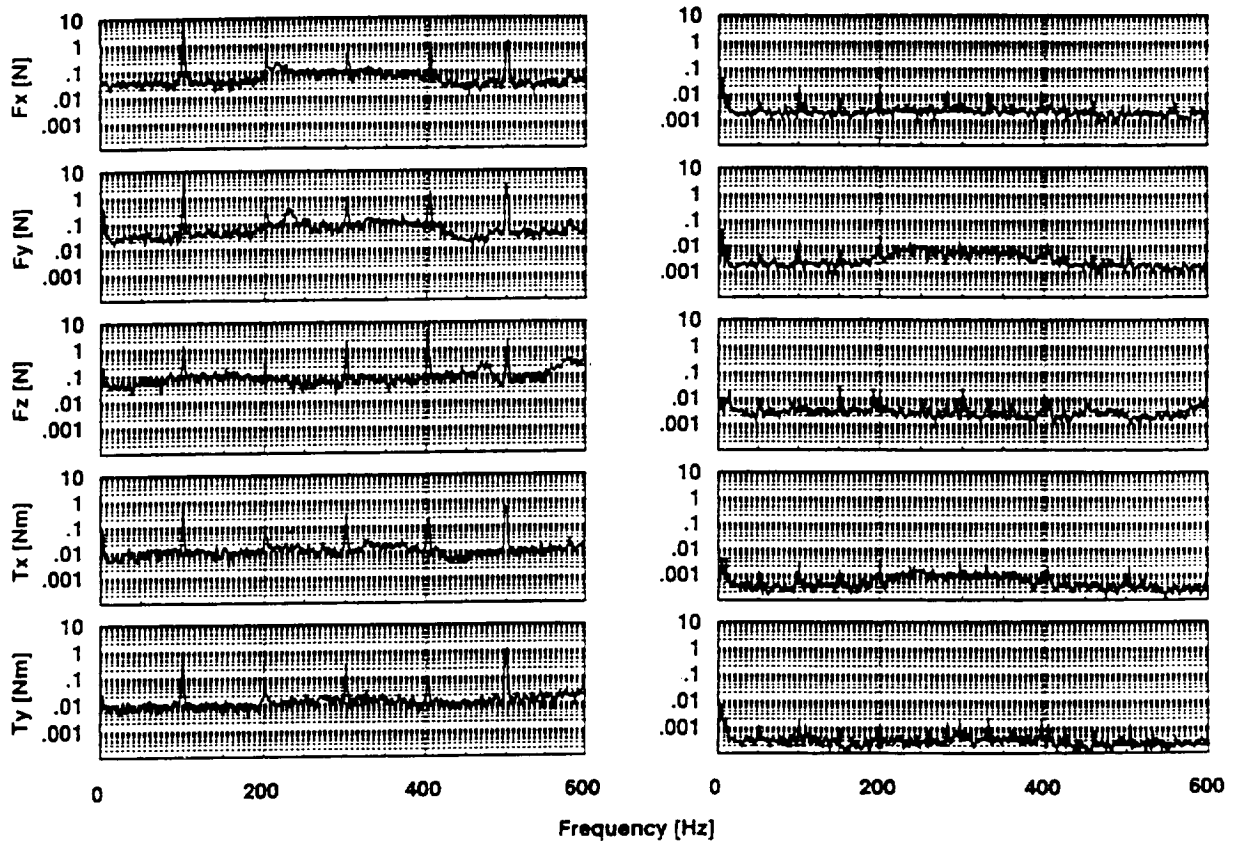

Fig. 9 Wheel Force and Torque at 6000 rpm (frequency domain) with conventional (left) and MFC controllers (right)

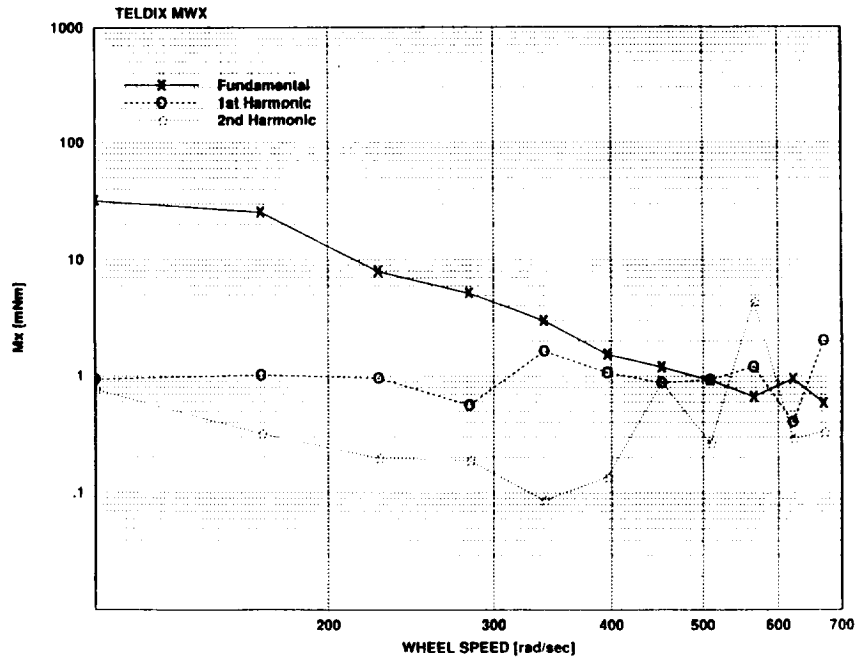

Fig. 10 Torque Noise Fundamental, 1<sup>st</sup> and 2<sup>nd</sup> Harmonics vs. Speed

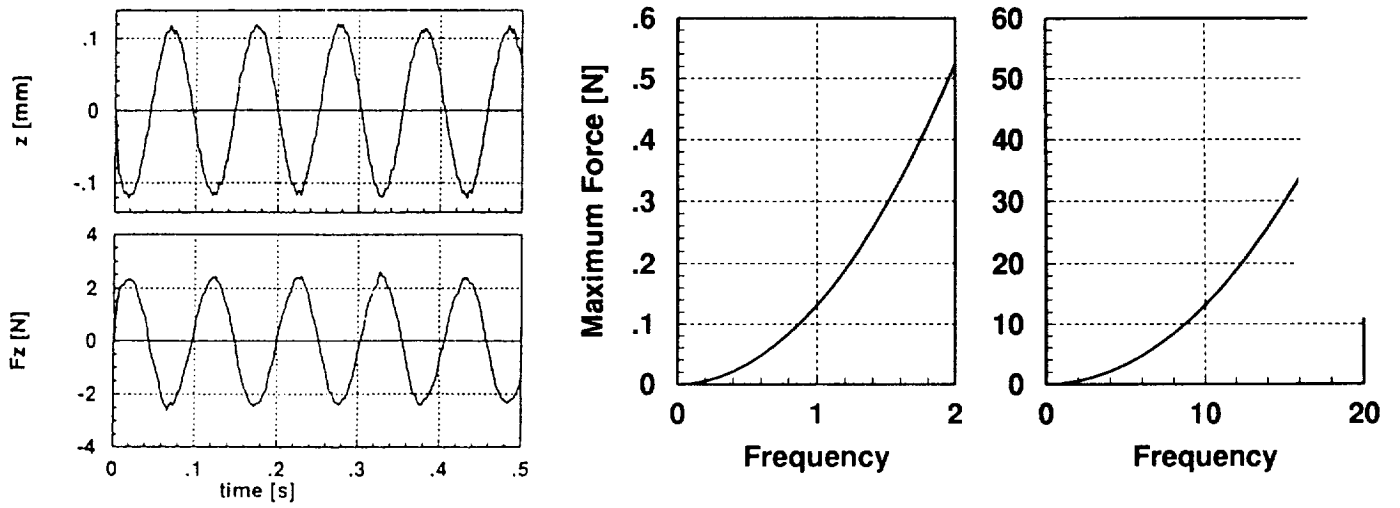

Fig. 11 Active Axial Force Generation and Maximum Possible Active Translational Force

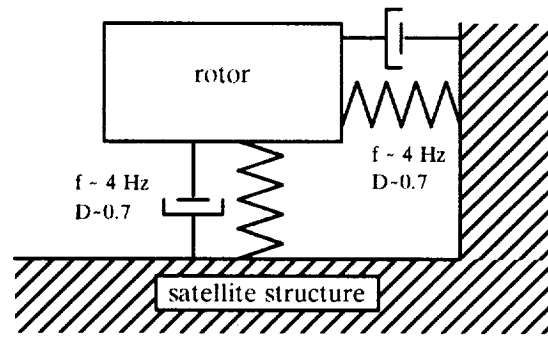

Fig. 12 Passive characteristic of the MW-X at low frequencies

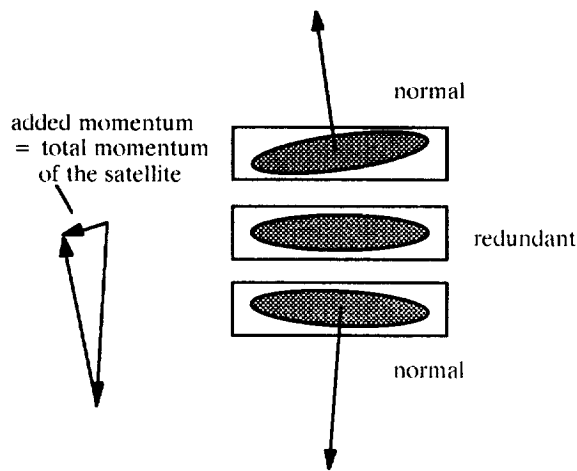

Fig. 13 Satellite with MW-X instead of a skewed arrangement of reaction wheels