

N94- 32455

**Electromagnetic Probe Technique
For Fluid Flow Measurements**2910
P-10**G.D. Arndt
NASA/Johnson Space Center
Houston, Texas 77058****J. R. Carl
Lockheed Engineering and Sciences Company
Houston, Texas 77058****Abstract**

The probes described herein, in various configurations, permit the measurement of the volume fraction of two or more fluids flowing through a pipe. Each probe measures the instantaneous relative dielectric constant of the fluid in immediate proximity. As long as separation of the relative dielectric constants of each fluid is possible, several or even many fluids can be measured in the same flow stream. By using multiple probes, the velocity of each fluid can generally be determined as well as the distribution of each constituent in the pipe. The values are determined by statistical computation. There are many potential applications for probes of this type in industry and government. Possible NASA applications include measurements of helium/hydrazine flow during rocket tests at White Sands, liquid/gas flow in hydrogen or oxygen lines in Orbiter engines, and liquid/gaseous Freon flow in zero gravity tests with the KS135 aircraft at JSC. Much interest has been shown recently by the oil industry. In this a good method is needed to measure the fractions of oil, water, and natural gas flowing in a pipeline and the velocity of each. This particular problem involves an extension of what has been developed to date and our plans to solve this problem will be discussed herein.

Introduction

The development of a microwave technique for measuring two-phase flow was originally started due to a desire to monitor the flow of monomethyl hydrazine and helium through an inlet pipe during tests at the White Sands Facility of a reaction control system (RCS) thruster jet. The relative amounts of helium and hydrazine flowing into the thruster jet could not be measured on an instantaneous basis. It was realized that since the dielectric constants of helium (approximately 1) and hydrazine (19.2) are sufficiently different, the load impedance seen by a microwave capacitance probe should also be sufficiently different to be easily separable.

The microwave technique that is described in this paper measures the phase angle of the reflection factor, S_{11} , associated with reflected energy from a flush-mounted probe. The system is in the process of being modified to include multiple probes within the pipe. This system has other potential space applications in measuring the flow of liquid and gaseous oxygen or hydrogen under zero-gravity conditions within the Space Station. The technique also has ground-based applications in measuring gas-water-oil flow from undersea oil wells as well as other possible uses in measuring volume fractions and the velocity of multiple liquids having different dielectric constants.

Applications

Single Non-intrusive Probe

There are many potential applications for a single, non-intrusive probe. For example, a single probe mounted at the top of a pipe can perform well as a bubble detector or void detector. A single probe mounted at the bottom of a pipe could be used to continuously monitor the purity of the fluid. A single probe mounted at an appropriate position on a mixing tank could monitor a change from fluid A to fluid B as a function of time. A single probe mounted strategically could be used to identify laminar or turbulent flow. A single probe may be all that is needed to monitor some point of interest in a pipeline. Combined with a priori information, flow regimes may be identifiable using a single probe. Of course, a single probe could be used to identify a full or empty tank, or an intermediate threshold level.

Multiple Non-intrusive Probes

Multiple non-intrusive probes could do any of the things mentioned previously. Identifying flow regimes, and calculating volume fractions could probably be accomplished better with multiple probes located at different positions on the pipe and performing additional processing. Velocity computations would require at least two probes at a known downstream spacing.

Multiple Intrusive Probes

In order to monitor directly what is happening in the interior of a pipe or reservoir, intrusive probes must be used (if using the type probe discussed in this paper). If multiple interior locations are to be monitored, then multiple probes are required. An example of this type of requirement comes from the oil industry. They have a need to measure the volume fraction of oil, water and natural gas flowing through a pipe and the velocity of each. It may be necessary, in this case, to gather data at the interior of the pipe.

If probes are internal, they must be made as minimally intrusive as possible. Also, they must be rigid enough to withstand the flow and tough enough to withstand corrosion and abrasion for long periods of time.

System Description

The major components of a single probe system are shown in Figure 1. This system has been built and used in a test program as described later.

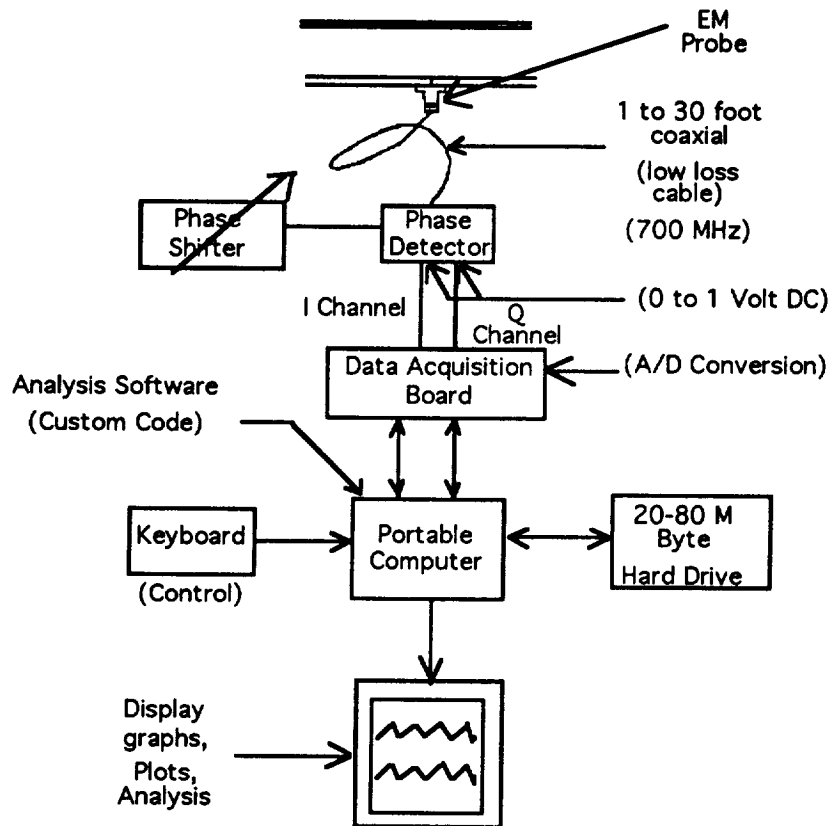

Figure 1. EM Probe System Block Diagram

Probe

The original probe is nothing more than a bulkhead SMA coaxial connector with the center conductor cutoff flush or nearly flush with the inside of the pipe wall. The teflon insulator around the center conductor is cut off flush with the inside of the pipe. Figure 2a shows four such probes mounted around the circumference of a pipe so that it can be determined what is flowing at the top, bottom, and both sides of a pipe. Figure 2b shows two probes at some known spacing to provide the velocity of the fluids flowing at the top of the pipe.

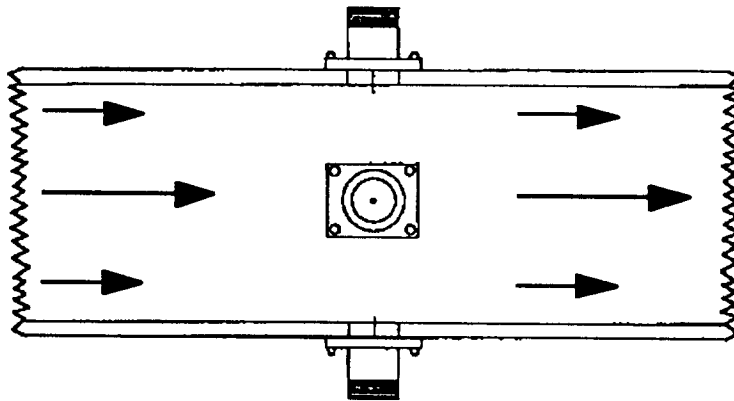

Figure 2a. Multiple Circumferential Probes

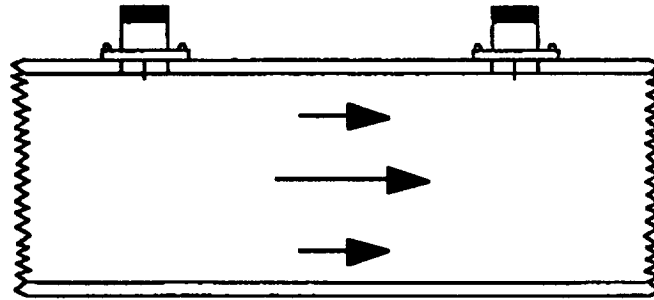

Figure 2b. Multiple Downstream Probes

Phase Detector

A block diagram of the phase detector is provided in Figure 3. This device measures the phase angle on the reflected signal from the probe at approximately 1 GHz. The signal is converted to 100 MHz, amplified, and quadrature phase detected. The two outputs of the phase detector is adjusted to be in the range of 0 to 5 volts. The phase detector was built in-house.

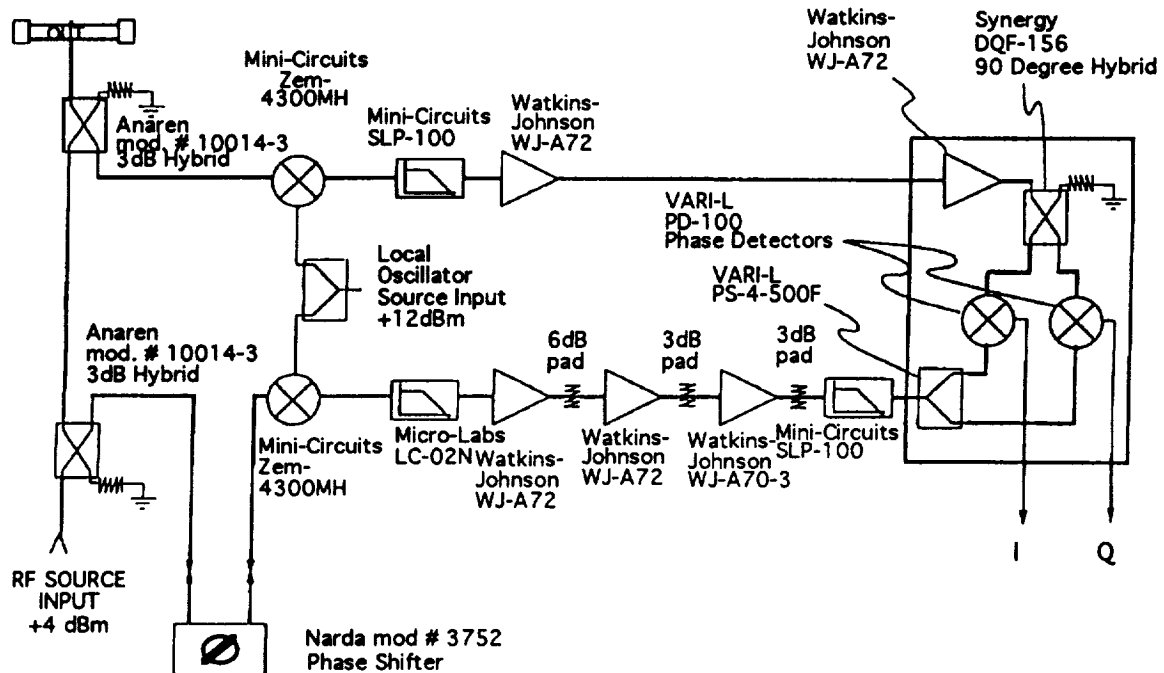

Figure 3. Phase Detector Block Diagram

Data Acquisition Board

There are many commercially available data acquisition boards in the form of expansion boards that are easily inserted into most personal computers (except some of the compact portables and/or notebook computers). Many channels can easily be obtained at reasonable cost and A/D conversion rates are generally available at up to 1 MHz. Conversion rates of 100 KHz are usually adequate.

Portable Computer

A 286 computer with a 20MB hard drive was used for the development of the single probe and used for the testing done to date. However, a 486-DX is being used for the development of the multiple probes with a 120MB hard drive.

Software

The software used for the development and testing of the single probe was written in the "ASYST" language. A commercially available software package called "Viewdac" was purchased for the development of multiple-probe configurations. This package should make it easier to acquire, store, process and display multiple data streams.

Theory of Operation

The small capacitance of the probe is used as the sensor. This capacitance is a function of the relative dielectric constant of the medium into which the probe is terminated. The short probe "sees" fluid that is no more than a short distance away. If it is required to see further into the medium, it would be necessary to increase the length of the probe so as to increase the volume around the center conductor that forms the probe capacitance.

The phase, or change of phase, associated with the reflected signal at the probe is the quantity measured. The complex "S" parameter associated with reflected energy "S₁₁" is given by:

$$S_{11} = \left(\frac{Z_0 - Z_L}{Z_0 + Z_L} \right) \quad (1)$$

Where: Z_0 is the characteristic impedance of the transmission line from phase detector to probe.

Z_L is the probe input impedance = $R + jX$

Typically, Z_0 is equal to 50 ohms. If there is a negligible energy coupled to the media, the probe resistance is very small. The input impedance is essentially a capacitive reactance in which case equation (1) can be written:

$$S_{11} = \left(\frac{50 - jX}{50 + jX} \right) \quad (2)$$

Where: $X = \frac{-1}{2\pi FC\epsilon_r}$

C = probe capacitance
 ϵ_r = relative dielectric constant
 F = frequency of operation

The phase " ϕ " on S_{11} , from equation (2), can be extracted as:

$$\phi = \tan^{-1} \left(\frac{100X}{2500 - X^2} \right) \quad (3)$$

for certain cases of interest, where X is large with respect to Z_0 and where ϕ is small, equation (3) reduces approximately to:

$$\begin{aligned} \phi &\approx -100 / X \text{ radians} \\ \phi &\approx -5730 / X \text{ degrees} \end{aligned} \quad (4)$$

For a certain 1mm probe, the probe capacitance has been measured to have a capacitance of approximately 0.04 pf. Using this value and using a frequency of 700 MHz equation (4) reduces to the convenient form:

$$\Delta\phi \approx \Delta\epsilon_r \quad (5)$$

For this model of the probe, i.e., a capacitive reactance termination for the transmission line, predictions can be made for probe capacitance given frequency, probe length, and the effective relative dielectric constant of the media. Also the probe's sensitivity can be readily formulated.

Test Results

The results shown in Figure 4 were extracted from the test results of a "Flapper Valve Experiment" performed at NASA, JSC, Houston Texas in November of 1992. The flush probe was mounted at the top of a 1^{1/2} inch pipe and monitored the flow of distilled water and dry nitrogen flowing at various specific rates through the pipe. The volume fraction of water and nitrogen were varied. The top graph shows that the probe works well as a bubble detector in this configuration. The lower two plots show two different conditions of slug flow. The precise volume fractions and flow rates are not immediately evident from these plots but by processing the data, introducing apriori knowledge, and by influencing the calculation with calibration data, perhaps reasonably accurate volume fractions and flow rates could be determined using only a single probe.

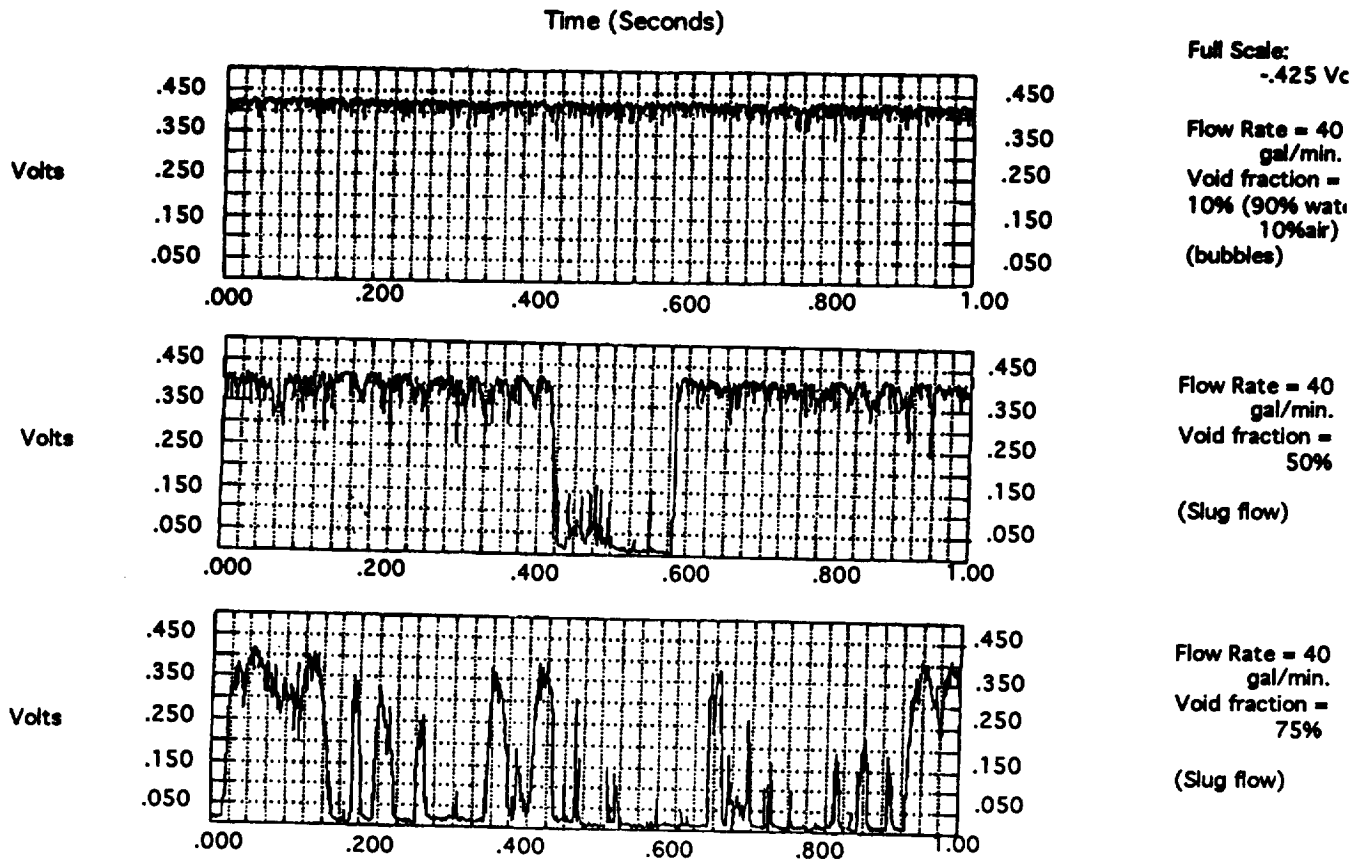

Figure 4. Flapper Valve Experiment Using Distilled Water and Nitrogen

Work In Progress

Certain potential applications of the AC fluid flow probe requires the use of multiple probes placed in the flow stream. For example, consider the problem of measuring the volume fraction of oil, water, natural gas, and oil/water emulsions (flowing in a pipe line). Various flow regimes are possible which may influence the choice of probe locations in the flow stream. By placing probes at various strategic locations within a cross-section of the pipe, the volume fractions of each constituent can be calculated statistically by a technique described herein. Also, by using an identical probe configuration downstream from the first, the velocity of each constituent can, in most cases, be measured.

Multiple in-flow probes can be used to measure many parameters, such as:

- Volume Fractions of Each Constituent
- Velocity of Each Constituent
- Blob Statistics
- Flow Regimes
- Flow Profiles

An Example Configuration of Multiple Probes in the Flow Cross-Section

One probe configuration presently under consideration consists of 2 vertical columns of 7 probes in each column. This configuration is presently being evaluated by computer simulation and is shown in Figure 5. It is believed that, in most cases, a good measurement of gas volume fractions and constituent velocities can be made for the horizontal flow of a non-homogeneous mixture of natural gas, oil, and water. Of course many other probe configurations are possible and can be tailored to the problem. For the flow conditions shown, the gas has a tendency to move toward the center of the pipe.

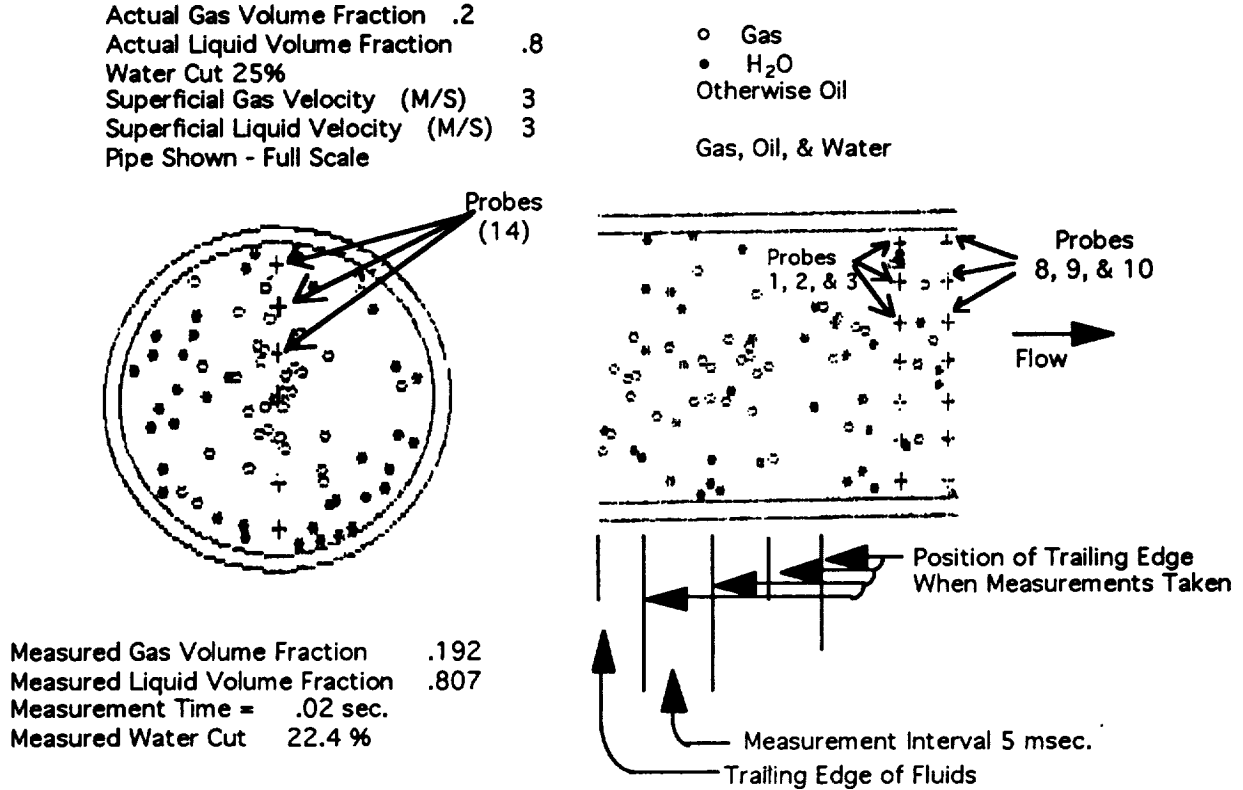

Figure 5. Computer Simulation Results

Multiplexing Probes

It is planned to multiplex the probes so that only one phase detector is required. In order to accomplish this, multiplexing using a switch must be done at RF and the switching device should be placed near the probes. Also the phase detector should be placed reasonably close to the multiplexer to reduce RF losses, maximize the probe sensitivity, and minimize cable induced phase shifts. The output of the phase detector is also multiplexed to sample and hold circuits that are assigned to specific probes. If this multiplexing scheme proves to be unsatisfactory for some reason, multiple phase shifters can be used instead.

Probe Pairs Used to Measure Velocity

The nature of the data streams from each probe is shown in Figure 6. The first column identifies the probe making the measurement. The remainder of the boxes contain numbers that identify the fluid that covers a specific probe at a specific time. Time increases from left to right. Probe 1 and Probe 8 form a an "upstream/downstream pair". Similarly probe 2 and 9 form a "pair" and so on. By sliding the second data stream along the first, a best match can be found. The time displacement required to obtain a match, along with the known probe spacing is all that is required to determine velocity.

This cross-correlation procedure can be performed on all seven pairs and for all three fluids. When this procedure was followed using much longer data streams, velocity could be determined very accurately.

1		1	1	1	1	1	1	2	2	2	2	2	1	1	1	1	1	1	1	1	3	3	
2		1	1	1	1	1	1	2	2	2	2	2	1	1	1	1	3	3	1	1	3	3	3
3		3	3	1	1	1	1	1	2	2	2	2	2	1	3	3	3	3	3	3	1	3	3
4		3	3	3	1	1	1	1	2	2	2	2	1	1	3	3	3	3	3	3	3	3	3
5		3	3	3	1	1	1	1	3	3	2	2	1	1	3	3	3	3	3	3	3	3	3
6		3	3	3	1	1	3	3	3	3	3	3	1	1	1	1	3	3	3	3	3	3	1
7		1	3	1	1	1	3	3	3	3	3	1	1	1	1	3	3	3	3	3	1	1	1
8		1	1	1	1	1	1	1	1	1	1	1	1	1	1	1	2	2	2	2	2	2	2
9		1	1	1	1	1	1	1	1	1	1	1	1	1	1	1	2	2	2	2	2	2	2
10		1	1	1	1	1	1	1	1	1	3	3	3	1	1	1	1	2	2	2	2	2	2
11		1	1	1	1	1	1	1	1	3	3	3	3	3	1	1	1	2	2	2	2	2	1
12		1	1	1	1	1	1	1	1	3	3	3	3	3	1	1	1	2	2	2	2	2	2
13		1	1	1	1	1	1	1	1	1	1	3	3	3	1	1	1	3	3	3	3	3	3
14		1	1	1	1	1	1	1	1	1	1	1	3	3	1	1	1	3	3	3	3	3	3

- USING PROBE 1 AND 8, THE MEASURED GAS VELOCITY IS 0 M/S
- USING PROBE 2 AND 9, THE MEASURED GAS VELOCITY IS 0 M/S
- USING PROBE 3 AND 10, THE MEASURED GAS VELOCITY IS 3.29 M/S
- USING PROBE 4 AND 11, THE MEASURED GAS VELOCITY IS 3.66 M/S
- USING PROBE 5 AND 12, THE MEASURED GAS VELOCITY IS 2.99 M/S
- USING PROBE 6 AND 13, THE MEASURED GAS VELOCITY IS 2.99 M/S
- USING PROBE 7 AND 14, THE MEASURED GAS VELOCITY IS 2.99 M/S

LEGEND: 1=OIL, 2=WATER, 3=GAS

Figure 6. Data Streams of Each Probe

Multiple Probe Design

Probe structures that are placed in the flow steam must be designed to have minimum impedance to flow and minimum effect on the flow while having good strength and durability characteristics. A prototype probe stack of 3 probes is presently being designed and is shown in Figure 7.

These probes should be large enough to provide a reasonable capacitance at 100 to 300 MHz (for sensitivity), yet small enough to be relatively invisible to the flow. Also the probes should be self-cleaning and should not interfere with each other electrically or physically.

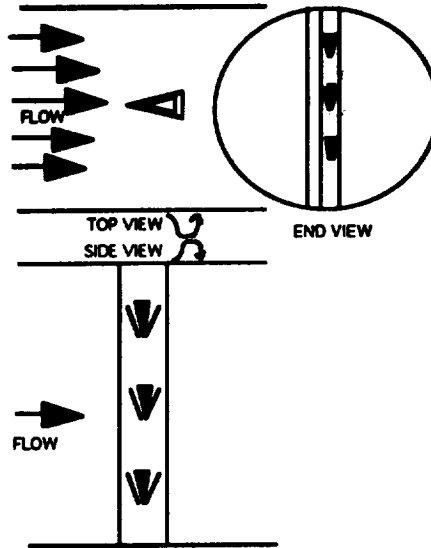

Figure 7. Prototype Stack of 3 Probes

References

A. Cartellier and J.L. Achord, *Local Phase Detection Probes in Fluid/Fluid Two-Phase Flows*, American Institute of Physics, February 1991.

D. Brown, J.J. den Boer and G. Washington, *A Multi-Capacitor Multiphase Flowmeter for Slugging Flow*, Shell Research Paper 2.2, North Sea Flow Measurement Workshop, October 1992.