

*** Final Report ***

MATERIALS PROCESSING APPARATUS DEVELOPMENT FOR FLUORIDE GLASS

Contract NAS8-38609, Delivery Order 102

Prepared by:

Guy A. Smith, Sue Kosten

and

Dr. Gary L. Workman
Principal Investigator

Submitted to

The National Aeronautical and Space Administration
George C. Marshall Space Flight Center
Marshall Space Flight Center, Alabama, 35812

The University of Alabama in Huntsville
Center for Automation and Robotics

March 31, 1994

N94-34388

Unclas

G3/27 0010378

(NASA-CR-193963) MATERIALS
PROCESSING APPARATUS DEVELOPMENT
FOR FLUORIDE GLASS Final Report
(Alabama Univ.) 26 p

Introduction

Optical fiber communication offers an exciting alternative to traditional wire communications. Extensive research over the past two decades helped in bringing down the transmission loss in silica fiber close to its theoretical limit of about 0.2 dB/km. However, the high density optical communication systems in the future would require optical fibers with losses far below those of silica fibers. Many infrared transmitting materials, such as heavy-metal oxides, halides, and chalcogenides, have the potential of having losses below 0.01 dB/km^(2,3,4). Amongst these, heavy metal fluoride glasses based on zirconium fluoride are most promising.

Fluorozirconate glasses have a broad transparency range, low refractive index, small dispersion, low Rayleigh scattering, and ultra-low thermal dispersion. In addition to fiber optics, they can be used in infrared remote sensing, laser power transmission, control systems for nuclear power plants, and various other applications. They offer a great deal of compositional flexibility, which could allow their properties to be tailored to a broad range. Although the theoretically predicted loss factor in fluoride glasses is around 0.001 dB/km⁽⁵⁾, the practical limitations in material purification brings this value up to around 0.02 dB/km.

Fluoride glasses have a narrow glass forming region. The large density difference between different components could lead to rapid phase separation and crystallization in these glasses under gravity. The microcrystallites formed in these glasses during synthesis or subsequent processing give rise to undesired scattering and higher than expected losses. Presently the losses obtained in these glasses are in the range of 1 to 100 dB/km, with best reported values of 0.7 to 0.9 dB/km^(6,7).

Previous studies of this nature⁽¹⁾ were incomplete in that the researchers observed no crystallization during flight. The conclusions drawn from that set of experiments noted that several variables, including the temperature profile were inadequately controlled for good scientific observations. The results did suggest that nucleation of microcrystallites does have a strong dependency on the temperature gradient at the solidification interface and any experimental work in this area needs to have that parameter under control.

Description of Hardware Development Activities

Section A. SYNOPSIS OF THE GLASS ANNEALING FURNACE

The purpose of this KC-135 experiment is to determine the effects of gravity on nucleation and growth of crystals in optical fiber. It is believed that in microgravity that there will be an absence of nucleation and growth and that these phenomena will be enhanced in the 2g portion of the parabola. The GAF will be used to anneal (not melt) the fibers in either low or high gravity. During the annealing process the growth of crystals maybe enhanced or retarded by the influence of gravity. The results of this experiment will be used in the development of Space Shuttle experiment. This research is intended to help develop a process to improve the transmission properties of commercial fiber optic cables.

The optical glass fibers will be sealed within a quartz ampoule to prevent deterioration from moisture while being heated. The ampoule is 60 mm long and 3 mm in diameter.

Section B. TEST OBJECTIVES

To process approximately 30 samples total, 15 in low-g and 15 in high-g. Results of the effects of low and high gravity upon crystal nucleation will be determined in the laboratory at MSFC, Alabama.

Section C. TEST DESCRIPTION

For each run one quartz ampoule containing one 30 mm long optical grade quartz fibers will be placed into the preheat furnace set to 300° C. At the appropriate time the ampoule will then be pushed into the annealing furnace set to 400° C and allowed to heat soak for approximately 10 seconds. Then it will be pushed into the quench chamber where water will be sprayed onto it and rapidly quench the sample. Quartz is very resistant to thermal shock at this low temperature, therefore the risk of the ampoule shattering is very minimal. A 0.125" diameter stainless steel rod is used to secure the ampoule and move or push the ampoule from one zone to the next in a straight line.

Section D. EQUIPMENT DESCRIPTION

The GAF is a relatively small package measuring 22"L x 10"W x 7.25"H and weighs less than 25 pounds. Its basic components are two furnaces, a water quench chamber and associated temperature control circuitry. The unit will be bolted down to a framework assembly fabricated from AMCO Engineering Co. stock materials which will act as a pedestal structure. This pedestal has flown twice in support of the KC-135 Fiber Pulling Apparatus in the past. It's safety information is contained within documents associated with the FPA experimental hardware and has already passed a JSC TRR.

The experiment processing area is contained within a Plexiglas housing and is vented to the aircraft's overboard dump system. The dump system is utilized for two reasons: ① To provide a means of removing the 50 to 60 ml of quench water and ② to maintain a slight negative pressure within the housing in the unlikely event that one of the sample ampoules should break. If an ampoule should break then no further action would be taken during that particular flight and the experiment would be shut down and recycled on the ground.

The electrical system is comprised of two temperature control systems - one for each furnace. An Omega model CN132 temperature controller will monitor the temperature of the particular furnace and apply or remove power to the heating element by controlling a International Rectifier solid state relay model TD1225 which is rated to 25 amps. There is only one 7.5 amp circuit breaker switch to control power to the entire system.

To quench the ampoule a 60 cc plastic syringe located outside the Plexiglas housing is connected via a plastic hose to the brass quench chamber located within the housing. The syringe contains only pure water and **does not utilize any type of needle.**

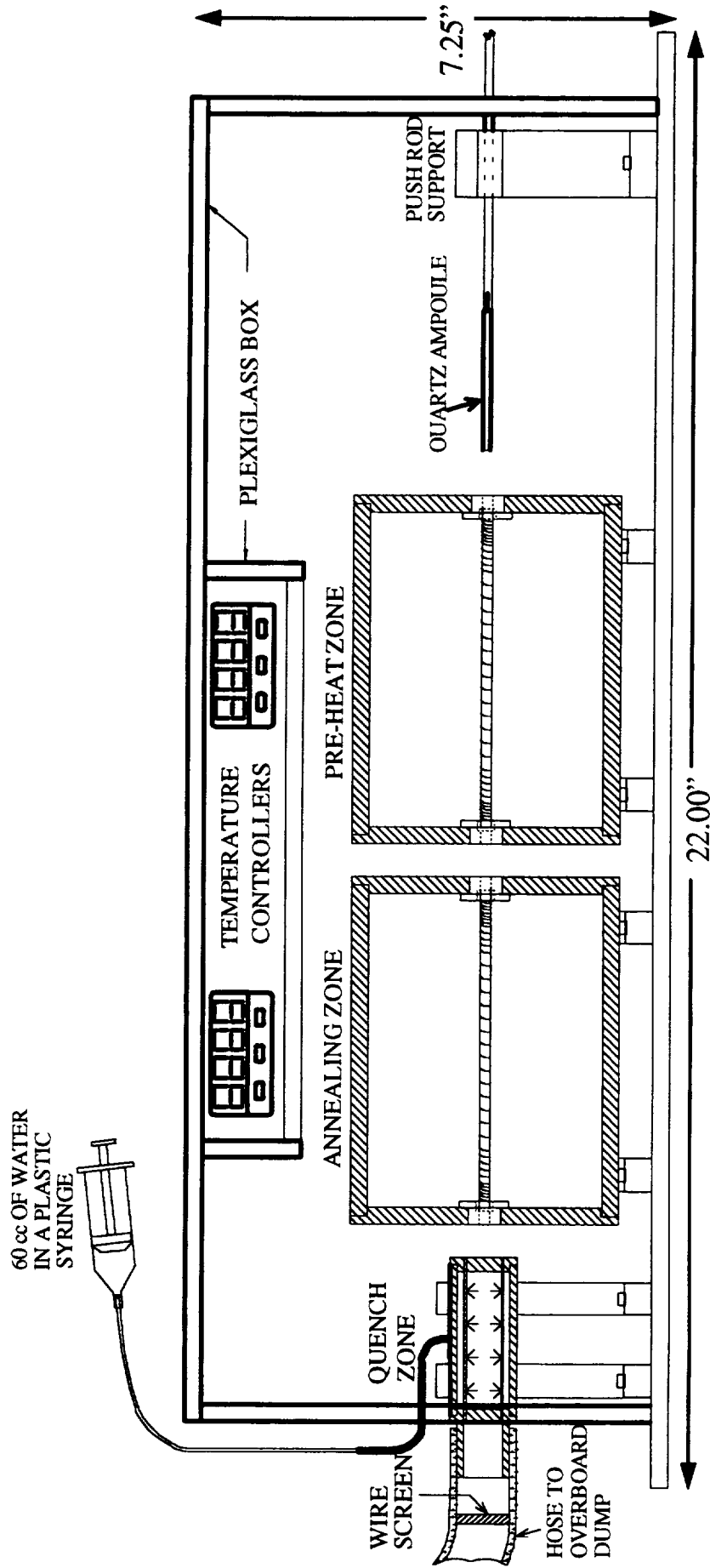

Figure 1. KC-135 Glass Annealing Furnace Concept Design

Section E. STRUCTURAL LOAD ANALYSIS

Two simplified case studies are presented dealing with the heaviest objects and the associated mounting points. The first case deals with the two bolts that mount the entire assembly (25 pounds) to the top of the support structure. This support structure has been flown aboard the KC-135 in the past for use with the Fiber Puller Apparatus and is referred to as the pedestal.

The second case shows an analysis of the heaviest object (the annealing zone furnace) and its associated hardware to the base plate. All total this item weighs 3.1 pounds and is the heaviest single item contained within the system.

It is our contention that these two studies represent the worst case conditions with this hardware. It should be pointed out that the reactive moment arm is included in the analysis with the center of gravity for the assembly at 3.5 inches up from the base plate, 9 inches from the left side and 5.5 inches from the front edge. It is assumed that the 9 g load is applied in the X and Z directions simultaneously along with a 2 g load in the Y direction.

Figures 2 and 3 provide sketches of the AMCO framework pedestal and where the GAF system is located with respect to the pedestal. The pedestal was originally designed to support the Fiber Puller Apparatus which weighed 146 pounds, therefore no structural analysis is considered necessary for this application since the GAF only weighs 25 pounds.

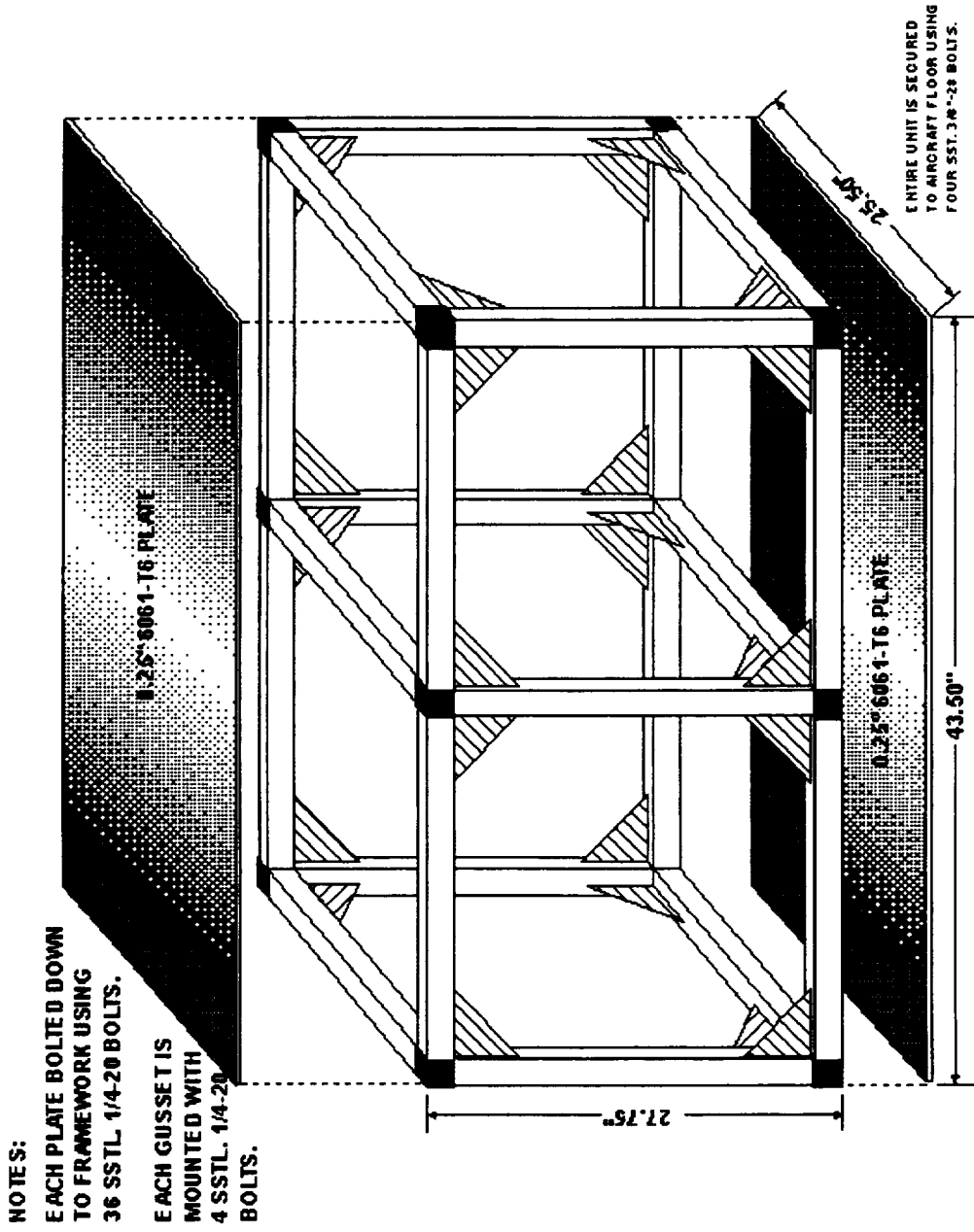

Figure 2: Exploded view of pedestal framework used on previous KC-135 Glass Fiber Pulling Apparatus.

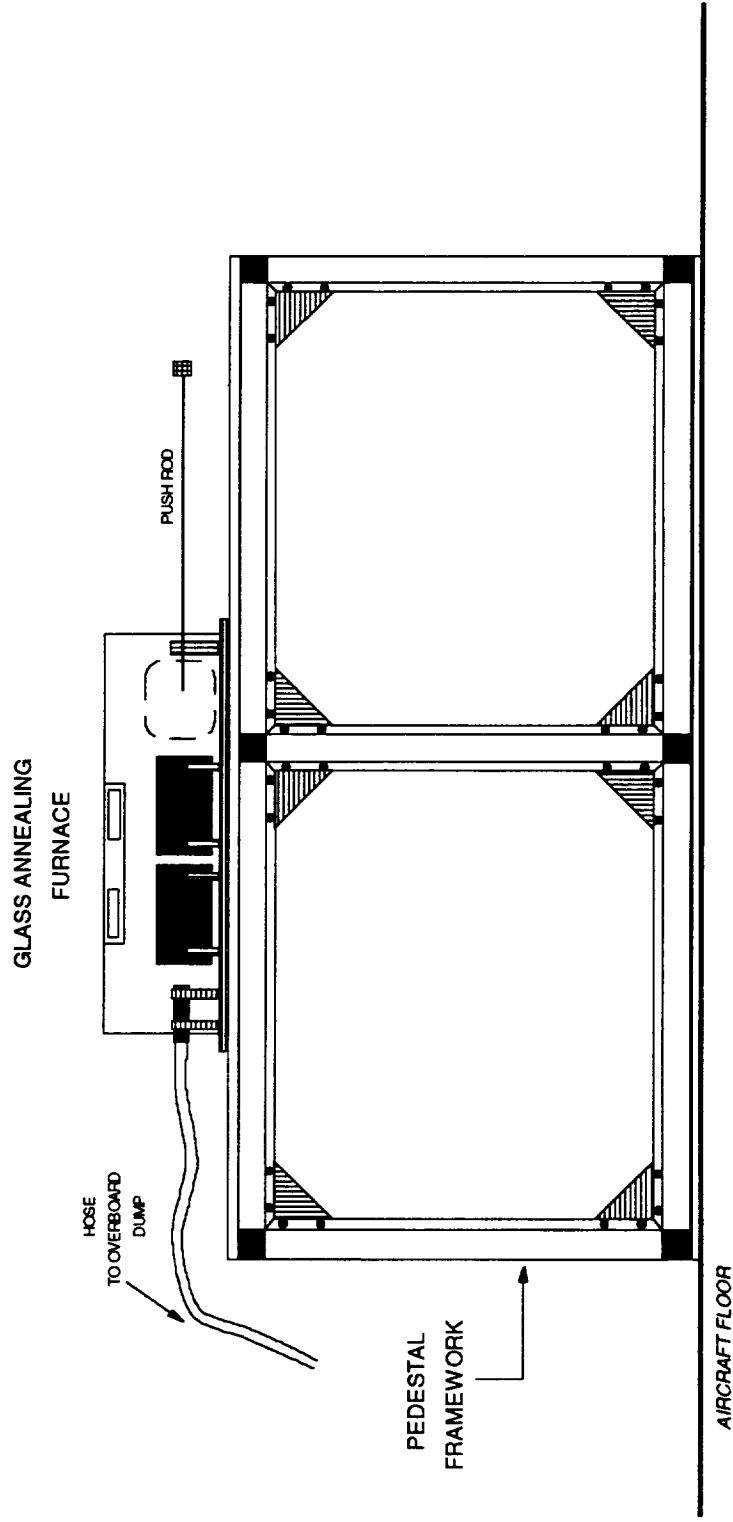

Figure 3: Assembly view of GAF attached to the pedestal framework.

Case 1: Glass Annealing Furnace Assembly to the Pedestal Framework.

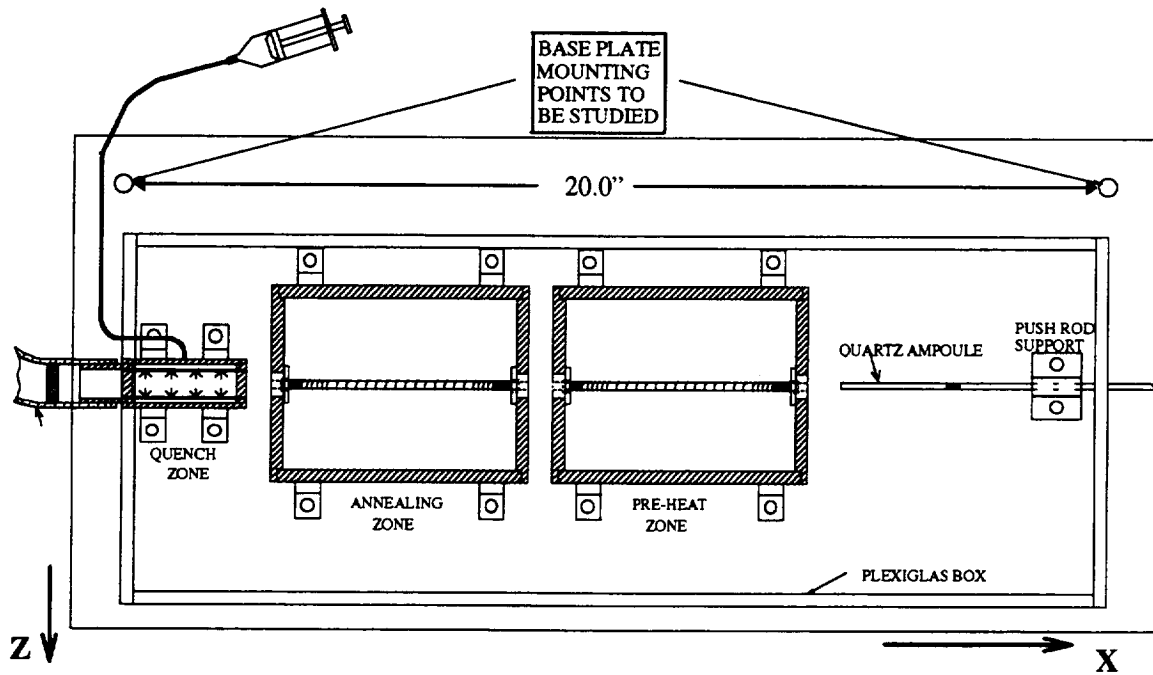

Figure 4: Top view of GAF assembly

TENSILE:

The reactive moment arm is calculated for the total tensile created which is distributed by the 2 bolts that mount the 1/4 inch thick base plate to the support structure. The center of gravity is located 9" on the X axis, 3.5" on the Y axis and 5.5" on the Z axis.

Tensile force for the free standing structure seeing 9 g's eyeballs in, out, left, or right and simultaneously along with 2 g's eyeballs up pulling apart from the 1/4 inch thick base plate will be:

$$\text{Direct Tension: } (25 \text{ lb.} \times 2 \text{ g's}) / 2 \text{ bolts} = 25 \text{ lb./fastner}$$

Moment from the X load:

$$M^x = 25 \text{ lb.} \times 9 \text{ g's} \times 6.519'' = 1,466.78 \text{ in}\cdot\text{lb}$$

$$M^z = 25 \text{ lb.} \times 9 \text{ g's} \times 9.657'' = 2,172.83 \text{ in}\cdot\text{lb}$$

Tension at "A" from M^x :

$$T_A = M^x / (2 \times 20'') = 1,466.78 / (2 \times 20'') = 36.67 \text{ lb.}$$

Tension at "A" from M^z :

$$T_A = M^z / (2 \times 20'') = 2,172.83 / (2 \times 20'') = 54.32 \text{ lb.}$$

$$\text{Total Tension} = 36.67 + 54.32 + 25 = 115.99 \text{ lb.}$$

The 3/8" stainless steel bolts used are rated to 13,798 lb. each. The force seen at 2 g's eyeballs up is 113 lb. pounds per bolt. Therefore, each bolt is $13,798/116 = 119$ times stronger than required for a tensile force of 2 g's eyeballs up along with 9 g's eyeballs in, out, left, or right. This value is approximate since it does not take into account shear or pre-loading of the bolt.

SHEAR:

For this case, primary shear is considered for all bolts that attach the base plate to the top of the pedestal framework. Shear stress seen across the mounting bolts at 9 g's eyeballs in, out, left, or right will be:

$$\text{Direct Shear: } (25 \text{ lb.} \times (9^2 \text{ g's} \times 9^2 \text{ g's})^{1/2}) / 2 \text{ bolts} = 159.10 \text{ lb./fastner}$$

$$\text{Total Shear} = 159.10 \text{ lb.}$$

Each bolt sees 159.10 pounds of direct shear force. The 3/8" stainless steel bolts used are rated to a shear strength of 8,279 lb. each. Therefore, each bolt is $8,279/159 = 52$ times stronger than the shear forces expected at 9 g's eyeballs in, out, right or left. This value is approximate since it does not take into account shear or pre-loading of the bolt.

Case 2: Annealing Zone Furnace to the Base Plate

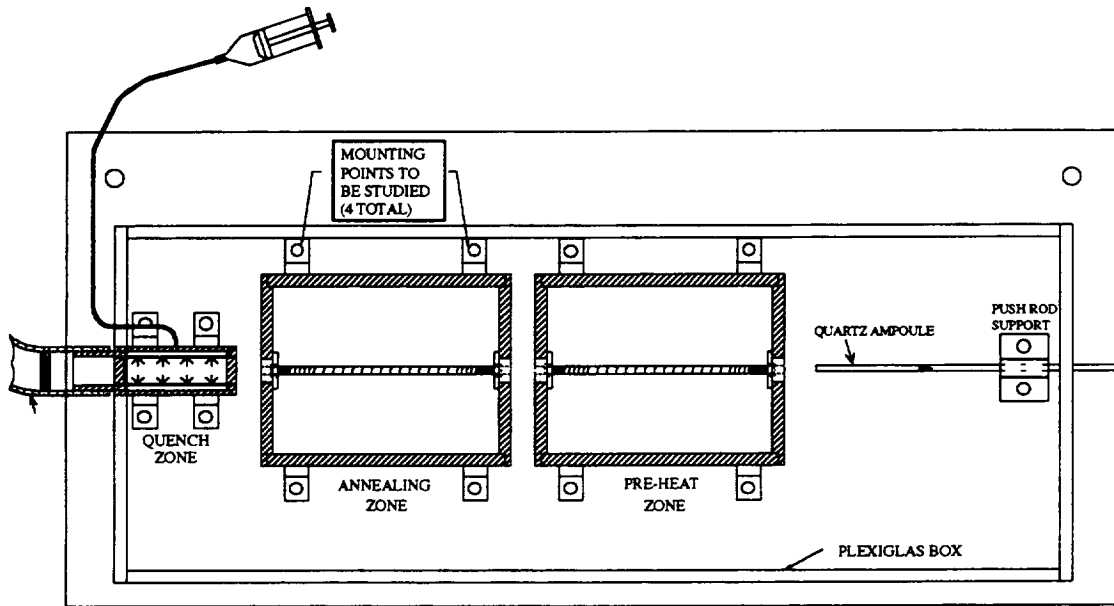

Figure 5: Top view of GAF assembly

The reactive moment arm is calculated for the total tensile created which is distributed by the four 10-32 stainless steel screws that attach the furnace mounts to the base plate. The center of gravity is located 2.5" on the X axis, 2" on the Y axis, and 2" on the Z axis.

Tensile force for the free standing structure seeing 9 g's eyeballs in, out, left, or right and simultaneously along with 2 g's eyeballs up pulling apart from the 1/4 inch thick base plate will be: (Assume moment arm is conservatively 4")

$$\text{Direct Tension: } (3.1 \text{ lb.} \times 2 \text{ g's}) / 4 \text{ bolts} = 1.55 \text{ lb./fastner}$$

Moment from the X load:

$$M^x = 3.1 \text{ lb.} \times 9 \text{ g's} \times 2" = 55.8 \text{ in'lb}$$

$$M^z = 3.1 \text{ lb.} \times 9 \text{ g's} \times 4" = 111.6 \text{ in'lb}$$

Tension at "A" from M^x :

$$T_A = M^x / (2 \times 3.75") = 55.8 / (2 \times 3.75") = 7.44 \text{ lb.}$$

Tension at "A" from M^z :

$$T_A = M^z / (2 \times 5") = 111.6 / (2 \times 5") = 11.16 \text{ lb.}$$

$$\text{Total Tension} = 7.44 + 11.16 + 1.55 = 20.15 \text{ lb.}$$

The 10-32 stainless steel screws used are rated to 3600 lb. each. The force seen at 2 g's eyeballs up is 20.15 pounds per screw. Therefore, each screw is $3600 / 20.15 = 178$ times stronger than required for a pure tensile force of 2 g's eyeballs up simultaneously along with 9

g's eyeballs in, out, left, or right. This value is approximate since it does not take into account shear or pre-loading of the screw.

SHEAR:

For this case, primary shear is considered for all bolts that attach the furnace to the base plate. Shear stress seen across the mounting bolts at 9 g's eyeballs in, out, left, or right will be:

$$\text{Direct Shear: } (3.1 \text{ lb.} \times (9^2 \text{ g's} \times 9^2 \text{ g's})^{1/2}) / 4 \text{ bolts} = 9.86 \text{ lb./fastner}$$

$$\text{Total Shear} = 9.86 \text{ lb.}$$

Each 10-32 stainless steel screw sees 9.86 pounds of direct shear force. The screws used are rated to a shear strength of 2,160 pounds each (60% of the tensile). Therefore, each screw is $2,160/9.86 = 219$ times stronger than the shear forces expected at 9 g's eyeballs in, out, right or left. This value is approximate since it does not take into account tensile or pre-loading of the screw.

Section F. ELECTRICAL LOAD ANALYSIS

This system uses 120 volts 60 Hz. AC only. A single 30 foot long 18 gauge power cord provides the AC power interface to the experiment. Total load for the experiment will be 5.0 amps maximum during the furnace heat up and will subsequently become intermittent once the furnace has reached temperature. The temperature controllers use timed proportioned control of the power to regulate temperature. Maximum current draw is limited by the resistance of approximately 50 ohms for each heating element.

The Omega model CN132 temperature controller maximum power draw is 2.5 watts and is internally protected with a 100 milliamp fuse.

On the following page is Figure 6 which identifies the AC power circuits, main power switch which is also a circuit breaker and wire gauges. Except for the power cord all wiring is TFE insulation and rated to 175° C. The 30 gauge thermocouple wire is insulated with glass braid insulation.

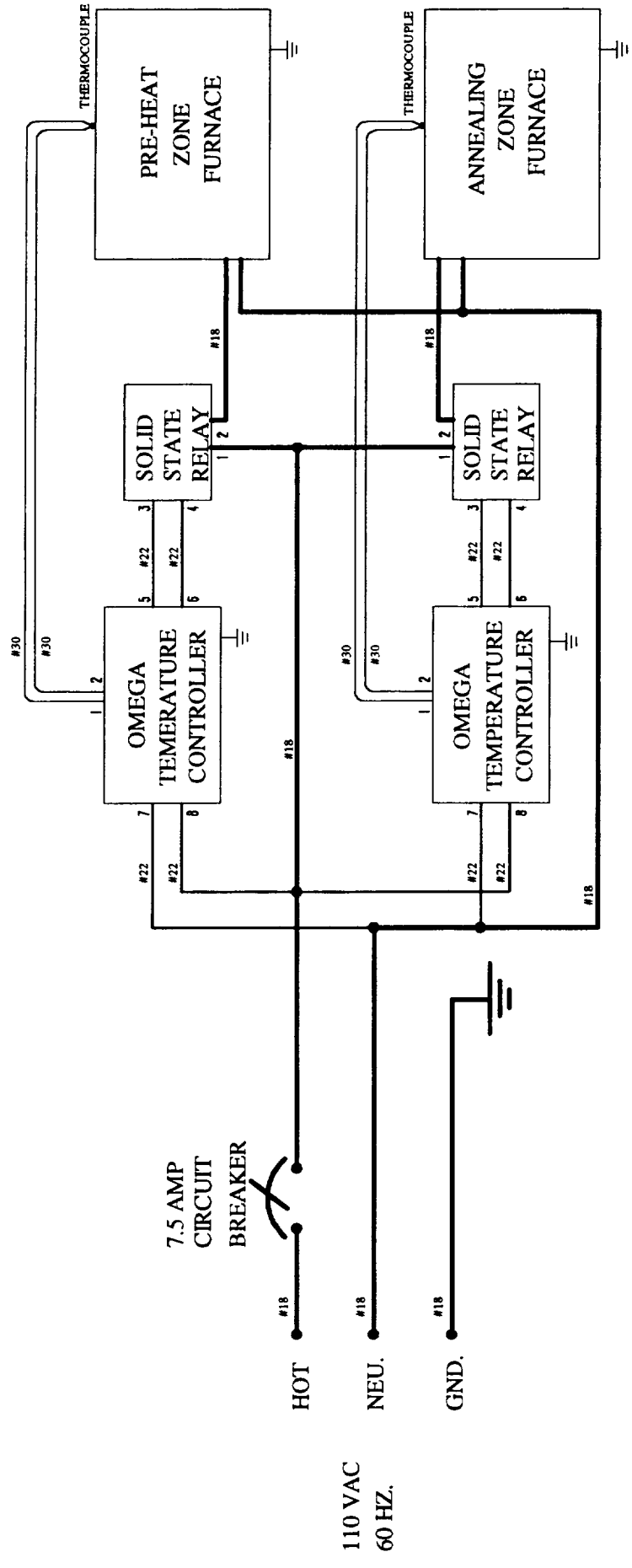

Figure 6: KC-135 Glass Annealing Furnace Electrical Diagram

Section G. PRESSURE VESSEL CERTIFICATION

No pressure vessels are contained within the system.

Section H. IN FLIGHT TEST PROCEDURES

During level flight one quartz ampoule will be removed from the supply case and inserted into the end of the push rod. With the access door closed, the ampoule will be loaded into the preheat furnace set at 300° C and allowed to heat soak for at least 5 minutes. Upon entering a low or high-g period the ampoule will then be pushed or loaded into the annealing furnace set to 400°C and allowed to heat soak for 10 to 15 seconds. At the end of this time period the ampoule will then be pushed into the water quench chamber. Here the 50 to 60 milliliters of pure water will be sprayed onto the ampoule by the plastic syringe and thus rapidly cool down the sample.

To recycle the experiment a new ampoule and plastic syringe filled with water will be installed during level or high-g flight.

Section I. PARABOLA REQUIREMENTS

During sample loading and unloading procedures a period of 1 to 2 minutes of high-g or level flight is all that is required. Only one parabola is needed to process anyone sample and can occur anytime after the required preheat period. It is hoped that 5 to 10 samples per flight can be processed.

Section J. TEST SUPPORT REQUIREMENTS, GROUND AND FLIGHT

There are only two test support requirements: ① The 110 Volt AC, 60 Hz. aircraft power be supplied at least 30 minutes prior to take off to allow the furnaces to heat up, and ② the overboard dump be available during the flight period. The air flow rate of the dump will be meter through the use of a ball valve and will not be operated in a full flow condition.

This project is unclassified and has no security restrictions.

Section K. DATA ACQUISITION SYSTEM

No data acquisition connections are required to be made to JSC equipment.

Section L. TEST OPERATING LIMITS OR RESTRICTIONS

An overboard dump system must be available for venting the quench water and provide a slight negative pressure inside the experiment housing for safety reasons. Intermittent power glitches do not pose any problems with the hardware.

Section M. PROPOSED MANIFEST FOR EACH FLIGHT

Two people are required to operate this experiment per mission. No JSC personnel are required.

Section N. PHOTOGRAPHIC REQUIREMENTS

There are no specific photographic requirements, occasional video and/or still photos for documentation may be requested as needed.

Section O. HAZARD ANALYSIS

The following pages details identified hazards associated with this experiment.

HAZARD REPORT NUMBER ONE

HAZARD TITLE: Glass fragments

DESCRIPTION OF HAZARD: Breakage of the quartz glass ampoule causing it to free float and possibly become a hazard to personnel.

HAZARD CAUSE: Thermal shock in association with a manufacturing defect to the glass ampoule.

HAZARD CONTROL:

1. Completely contain the experiment in Plexiglas so that the ampoule material can not escape.
2. Implement overboard dump system to maintain slight negative pressure on experiment housing and vent the Plexiglas housing continuously.
3. Keep access doors closed during parabolas.

VERIFICATION METHOD:

1. Visual inspection.
2. Proper procedure during operation.
3. Proper procedure during operation.

VERIFICATION STATUS:

1. Inspection complete - no means for the ampoule fragments to escape with the access door closed.
2. Real time operational procedures.
3. Real time operational procedures.

HAZARD REPORT NUMBER TWO

HAZARD TITLE: Implosion of the Plexiglas housing.

DESCRIPTION OF HAZARD: Possible injury to personnel due to Plexiglas fragments.

HAZARD CAUSE: The overboard dump valve is fully opened creating too great a vacuum within the experiment housing.

HAZARD CONTROL: Insure that the Plexiglas housing is not air tight and thus preclude the possibility of vacuum build up.

VERIFICATION METHOD: Inherent to the design.

VERIFICATION STATUS: Inspection complete - There are sufficient air leaks through the Velcro seals on the Plexiglas access door and through the housing vent port to prevent excessive vacuum build up.

HAZARD REPORT NUMBER THREE

HAZARD TITLE: Sharp corners and protrusions on the hardware.

DESCRIPTION OF HAZARD: Injury to personnel due to contacting sharp corners, or protrusions during flight.

HAZARD CONTROL:

1. Insure that all sharp corners that are exposed have been rounded to a radius of no less than 0.250”.
2. Add foam rubber padding as required to satisfy safety requirements at Ellington Air Field, JSC.

VERIFICATION METHOD:

1. Visual inspection of hardware.
2. Visual inspection of hardware.

VERIFICATION STATUS:

1. Complete - All exposed corners have been rounded to a 0.250” radius.
2. Not complete - To be determined at Ellington Air Field during the TRR.

HAZARD REPORT NUMBER FOUR

HAZARD TITLE: Electrical shorts or electrical shock.

DESCRIPTION OF HAZARD: Water from the quench system resulting in electrical shorting to the system or to personnel.

HAZARD CAUSE: Free floating water from the quench zone within the experiment housing coming in contact with electrical systems.

HAZARD CONTROL:

1. Protect all electrical connections from water.
2. Keep plumbing to a minimum around electronics.
3. Use the minimum amount of water necessary.
4. Use overboard dump to catch and remove quench water from the quench chamber.

VERIFICATION METHOD:

1. Visually inspect electrical connections to see if they are shielded from the water spray.
2. Visually check placement of quench system plumbing.
3. Visually inspect the amount of water needed and verify that this amount is used.
4. Proper procedure during in flight operations.

VERIFICATION STATUS:

1. All electrical connections are protected from water spray.
2. Quench system plumbing isolated from electronics where possible.
3. Smallest quantity of water (60 cc) is used for the quench system and is limited by the size of the plastic syringe.
4. Real time operational procedures.

HAZARD REPORT NUMBER FIVE

HAZARD TITLE: Touch Temperature

DESCRIPTION OF HAZARD: Surface temperature of the quartz ampoule exceeding 45°C.

HAZARD CAUSE: During removal of quartz ampoule from the quench chamber after processing the surface temperature could still possibly exceed 45°C causing possible burn hazard to personnel.

HAZARD CONTROL: Use quenching water in conjunction with air flow provided by the overboard dump to cool the sample down to below 45°C prior to removal from the quench chamber.

VERIFICATION METHOD: Ground based in lab testing to confirm that the above hazard control is sufficient.

VERIFICATION STATUS: Lab tests were conducted to date prove the above hazard control is sufficient to prevent possible burn hazard to personnel.

HAZARD REPORT NUMBER SIX

HAZARD TITLE: Fire Potential of the Two Furnaces

DESCRIPTION OF HAZARD: Flammability assessment of furnace materials

HAZARD CAUSE: Flammability of materials used in the construction of the two furnaces.

HAZARD CONTROL: Insure that materials used in the construction of the two furnace do not pose an ignition source.

VERIFICATION METHOD: Insure that materials used do not pose a ignition source. The following provides a material list and associated flammability of all components used in the construction of each furnace starting with the inner most component and working outward. The following picture indicates location of each item within the furnace.

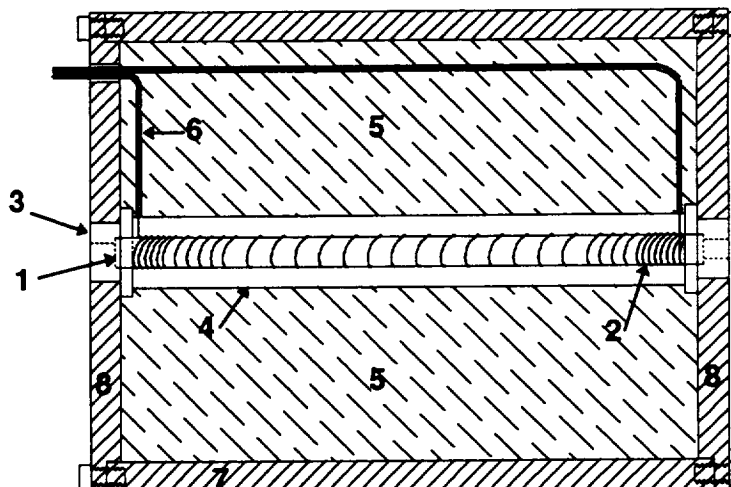

Materials list for components used in the construction of each furnace.	
Item	Flammability
1. Alumina tubing, Al_2O_3	0
2. Nichrome heating element wire	0
3. Lava stone insulators, $Al_6O_4 \bullet Si_2O_4$	0
4. Norton's EA-139 potting compound, $Al_2O_3 \bullet 3H_2O + MgO$	0
5. Kaowool fiber insulation, $Al_2O_3 \bullet 2SiO_2 \bullet 2H_2O \bullet MnO_2$	0
6. Ceramic bead insulators, Al_2O_3	0
7. 6061-T6 Aluminum tube, 4" O.D.	0
8. 6061-T6 Aluminum end plates	0

VERIFICATION STATUS: By inspection the above table indicates that none of the materials used in the construction present any type of ignition source.

HAZARD REPORT NUMBER SEVEN

HAZARD TITLE: Fire Potential of Electrical Components

DESCRIPTION OF HAZARD: Flammability assessment of electrical components

HAZARD CAUSE: Flammability of materials used in the temperature control system.

HAZARD CONTROL: Insure that materials used in the construction of the temperature control system do not pose an ignition source.

VERIFICATION METHOD: The following provides a material list and associated information.

Materials list used in the temperature control system	
Item	Material Specifications
1. Omega CN132 temperature controller 2 each	Conformity testing to UL873, CSA22.2/142-87, IEC664:1980, All external moldings fabricated from flame retardant polycarbonate.
2. International Rectifier solid state relay, model TD1225, 2 each	Outer case fabricated from GE Valox, electrical components contained within Hysol two component epoxy resin. Both materials meet UL94V-O flammability spec.
3. Teflon coated wire, 22 and 18 gauge	Rated to 175°C
4. Plexiglas housing, MC grade acrylic used in protecting electronics from quench water.	Flammability class UL94HB, Horizontal burning test avg. burn rate per ASTM D635 is 1.0 in/min. Max. recommended continuous service temp per ASTM D648 was 190°F

VERIFICATION STATUS: By inspection all of the above materials with the exception of the Plexiglas meet flammability requirements.

HAZARD REPORT NUMBER EIGHT

HAZARD TITLE: Smoke and or Fire

DESCRIPTION OF HAZARD: Flammability of Plexiglas housing

HAZARD CAUSE: Overheating of Plexiglas caused by contacting hot quartz or overheating of the solid state relays which are mounted directly to Plexiglas panel.

HAZARD CONTROL:

1. Use of the over board dump will help to preclude any chance of a hot (400°C) quartz ampoule or pieces of ampoule from coming in contact with Plexiglas surfaces.
2. Ampoules will be contained at any point of time while hot within either furnace housing or quench chamber and thus preclude any change of contact with the Plexiglas.
3. If solid state relay should fail and overheat remove power from system by manually tripping circuit breaker if breaker fails to trip automatically.
4. If a catastrophic failure did occur resulting in a fire Halon fire extinguishers are available within easy reach on board the KC-135.

VERIFICATION METHOD:

1. Proper procedure during in flight operations.
2. By inspection confirm that ampoules can not escape furnace housings.
3. Proper procedure during in flight operations.
4. By inspection determine if fire extinguishers are available on board the KC-135.

VERIFICATION STATUS:

1. Real time operational procedures by the operator.
2. Inspection complete - ampoules can not escape furnace housing.
3. Real time operational procedures by the operator.
4. Inspection complete - fire extinguishers are standard equipment on board the KC-135.

References

1. S. Varma, S. E. Prasad, O. Murley, T. A. Wheat, *Use of Microgravity for Investigating Phase Separation and Crystallization in a Heavy Metal Fluoride Glass*, SPIE Vol 1591, (1991).
2. D. A. Pinnow, A. L. Gentile, A. G. Standlee, A. J. Timper, and L. M. Hobrock, *Applied Physics Letters*, 33, 28, (1978).
3. L. G. Van Uitert, S. H. Wemple, *Applied Physics Letters*, 33, 57, (1978).
4. C. H. L. Goodman, *Solid State Electron Development*, 2, 129, (1978).
5. M.G. Drexhage, B. Bendow, O. El-Bayoumi, R. N. Brown, P. K. Banerjee, T. Loretz, C. T. Moynihan, J. J. Shaffer, P. A. Temple and H. E. Bennett, 13th Moulder Laser Damage Symposium, NBS, Boulder, Colorado, Nov. 17-18, (1982).
6. D. C. Tran, Presented at Conference on Optical Fiber Communication, Atlanta, (1986).
7. T. Kanamori and S. Sakaguchi, *Journal of Applied Physics*, 25, L468, (1986).

