

NASA Technical Memorandum 108803

---

# Final Report of the U.S. Experiment Flown on the Soviet Biosatellite Cosmos 1667

---

John W. Hines, and Michael G. Skidmore, Editors  
Ames Research Center, Moffett Field, California

May 1994



National Aeronautics and  
Space Administration

**Ames Research Center**  
Moffett Field, California 94035-1000



## **PREFACE**

This Memorandum describes the U.S. Primate Cardiovascular Experiment which flew aboard the Soviet biosatellite mission, Cosmos 1667, in 1985. The experiment was designed to study cardiovascular changes in non-human primates exposed to a microgravity environment. The material contained herein has been extracted from various U.S. documents written in preparation for, and following the flight of Cosmos 1667. Earlier reports relating to the Cardiovascular Experiment are briefly described in a Document Overview section. More detailed information about U.S./U.S.S.R. joint experiments flown aboard previous Cosmos missions can be found in the technical memorandums published for Cosmos 782, 936, 1129, and 1514 (1,2,3,4).

This report consists of two main parts: section I includes a description of the mission and section II contains an analysis of data collected for the Cardiovascular Experiment. The experiment consisted of a 7-day spaceflight study, a delayed synchronous ground-based control experiment, vivarium control studies, and orthostatic (tilt) tests and cross calibration tests of a vascular cuff transducer implanted in the primate.

The Cardiovascular Experiment was basically a repeat of the experiment flown aboard Cosmos 1514 in 1983, although several improvements were implemented for the 1667 mission. The data and summary results described include some comparisons of the Cosmos 1514 and 1667 Cardiovascular Experiments.

We gratefully acknowledge our Soviet colleagues, who in 1985 provided the opportunity to conduct this flight experiment and made major contributions to its success.

James P. Connolly  
Cosmos Project Manager  
NASA Ames Research Center  
Moffett Field, California  
May 1994



## TABLE OF CONTENTS

Preface.....	iii
Summary .....	1
I. Mission Description.....	2
A. Introduction .....	2
B. Mission Operations.....	3
C. U.S. Bioinstrumentation Development.....	5
D. References .....	7
E. Figures and Tables.....	8
II. Primate Cardiovascular Flight Experiment and Ground Based Controls.....	25
A. Introduction.....	26
B. Methods.....	26
C. Data Analysis.....	28
D. Results.....	30
E. Discussion and Conclusions.....	39
F. Recommendations .....	41
G. References .....	42
H. Figures and Tables.....	43
III. Cosmos 1667 Documents Overview.....	127



# FINAL REPORT OF THE U.S. PRIMATE CARDIOVASCULAR EXPERIMENT FLOWN ON THE SOVIET BIOSATELLITE COSMOS 1667

John W. Hines and Michael G. Skidmore, Editors

Ames Research Center  
Moffett Field, California

## SUMMARY

Two male young-adult rhesus monkeys were flown on the Soviet Biosatellite Cosmos 1667 for seven days from July 10-17, 1985. Both animals were instrumented to record neurophysiological parameters. One animal, Gordyy, was additionally instrumented to record cardiovascular changes. Space capsule and environmental parameters were very similar to those of previous missions. On Cosmos 1514, which flew for five days in 1983, one animal was fitted with a left carotid artery cuff to measure blood pressure and flow velocity. An additional feature of Cosmos 1667 was a postflight control study using the flight animal. Intermittent postural tilt tests were also conducted before and after spaceflight and synchronous control studies, to simulate the fluid shifts associated with spaceflight. The experiment results support the conclusion derived from Cosmos 1514 that significant cardiovascular changes occur with spaceflight. The changes most clearly seen were rapid initial decreases in heart rate and further decreases with continued exposure to microgravity. The triggering mechanism appeared to be a headward shift in blood and tissue fluid volume which, in turn, triggered adaptive cardiovascular changes. Adaptive changes took place rapidly and began to stabilize after the first two days of flight. However, these changes did not plateau in the animal by the last day of the mission.

# I. MISSION DESCRIPTION

## A. INTRODUCTION

Both the U.S. and U.S.S.R. space programs have used animal payloads to prepare for manned spaceflights and to understand human physiologic responses to space (1,2,3,4). Non-human primates are ideal subjects for study because they are similar to man not only in their physiology but also in their upright posture. Prior to this mission, work with primates in space was limited to four U.S. and two Soviet flights. Two chimpanzee flights of very short duration conducted by the U.S. in 1961 preceded the first U.S. manned flight. In 1969, a single pig-tailed monkey was flown for only 8.8 days of a planned 30 day mission. The U.S. successfully flew two uninstrumented squirrel monkeys aboard the 7-day Shuttle mission of Spacelab 3 in 1985. The Soviets flew two missions with chronically instrumented non-human primates, the 5-day Cosmos 1514 flight of 1983 and the 7-day Cosmos 1667 flight discussed in this memorandum. Since the completion of the 1667 mission and the writing of this section, the Soviets have flown three additional missions with U.S. involvement; Cosmos 1887 in 1987, Cosmos 2044 in 1989 and Cosmos 2229 in 1992, each of which contained two rhesus monkeys (5,6).

Although spaceflight experience with primates has been fairly limited, they have been used in a substantial number of ground-based studies (7). Such studies are invaluable in helping to interpret findings from spaceflight. Results of ground-based cardiovascular experiments have shown that rhesus monkeys undergo definite changes in cardiovascular system regulation following ground-based simulations of weightlessness as well as during actual spaceflight (8). The cardiovascular experiment conducted on Cosmos 1667 was designed to further define the magnitude of, and assess possible mechanisms for these changes.

The primary goals for U.S. participation in the Soviet Cosmos 1667 Mission were:

- To use an implantable vascular cuff to measure carotid artery pressure and blood flow in 3-5 kg rhesus monkeys, and to provide all flight and ground support instrumentation for the experiments.
- To transfer raw physiological data obtained from the implanted cuff during flight and ground control experiments to a U.S. analog tape recording system for subsequent data analysis at the Cardiovascular Research Laboratory, NASA Ames Research Center.

There were two secondary goals for the Cosmos Primate Cardiovascular Experiment. One was to use the data obtained to estimate oxygen delivery capacity to the brain during spaceflight. This procedure was postponed for a future mission because it necessitated ligation of the external carotid artery. Another goal was to correlate hemodynamic data with other Soviet data recorded concurrently. Such a correlative analysis was performed during one aspect of the Cosmos 1514 mission, when blood flow velocity in the carotid during flight was compared to total body cardiac output as determined by impedance cardiography.

The 7-day Cosmos 1667 mission was launched on July 10, 1985 and recovered July 17, 1985. Conditions with respect to mission parameters were very similar to those of Cosmos 1514 as shown in Table 1. Table 2 provides a complete list, by subject type, of investigations onboard Cosmos 1667 from many countries, including other studies utilizing the two rhesus monkeys (*Macaca mulatta*). The two primates, Gordyy (previously named Feemka), and Oomka, were instrumented for Soviet neurophysiological studies. This instrumentation consisted of bilaterally implanted microelectrodes in the vestibular nuclei,



and electrooculogram (EOG) and electroencephalogram (EEG) electrodes. Gordyy was additionally instrumented for cardiovascular studies, specifically to measure blood pressure and flow in the left common carotid artery. Gordyy was the second animal to be instrumented to measure cardiovascular changes during spaceflight, the first being Bion flown aboard Cosmos 1514.

Two kinds of control studies were carried out to aid in the interpretation of the inflight cardiovascular experiment data. The post-flight ground-based synchronous (actually, delayed) control experiments (9-16 August 1985) were designed to duplicate the flight environment except for factors unique to the spaceflight, namely weightlessness and exposure to space radiation. The animals studied during the synchronous control study were Gordyy, and two cardiovascularly (CV) instrumented, non-flight primates, Kvak and Samurai. The vivarium control was designed to collect as much data as possible with subjects housed in normal laboratory conditions, to control for all factors unique to the internal spacecraft environment. In addition to the control studies, orthostatic (tilt) tests were carried out on Gordyy, Kvak, Samurai and on three other CV instrumented, non-flight primates, Angel, Fronya and Troll. Postural tilt tests were designed to simulate gravitational fluid shifts that occur with spaceflight. Response to preflight tilt was used as a screening procedure in selection of candidate flight animals. Response to tilt was also used to assess the presence or absence of cardiovascular deconditioning (altered heart rate, blood pressure and/or blood flow levels) following flight and synchronous control experiments. Table 3 shows the major tests carried out on each of the CV instrumented animals.

## B. MISSION OPERATIONS

### 1. General Experiment Design

Except for the modifications listed below, the experiment design for the Cosmos 1667 Primate Cardiovascular Experiment was the same as for Cosmos 1514. Problems encountered while conducting the cardiovascular experiment aboard Cosmos 1514 resulted in corresponding improvements for Cosmos 1667. Implemented changes are described in detail in the final science report for Cosmos 1667 (8). The modifications (italicized) included:

- Data for the Cardiovascular Experiment was recorded continuously for 5 minutes every 30 minutes during the lights-off period and continuously for 5 minutes every 2 hours during the lights-on period. Data was recorded on Cosmos 1514 for 5 minutes every 2 hours throughout the experiment.
- Both flight animals were implanted with neurovestibular electrodes (microelectrodes in the vestibular nuclei bilaterally, EOG sensors and EEG electrodes). A single non-CV instrumented animal was flown aboard Cosmos 1514.
- Two CV instrumented animals, in addition to the flight animal, were studied under ground-based synchronous control conditions. No postflight CV tests were conducted following Cosmos 1514.
- Animal handling procedures were modified during the preflight training period and postflight tests, to prevent potential damage to the transducer implant in the neck area.

- Tilt tests were carried out before and after flight and synchronous control experiments in as many animals as possible to establish a ground-based data pool for this procedure. This was not done on Cosmos 1514.
- Instrument calibration procedures were modified to ensure accuracy of blood pressure measurements. A fixed reference resistance ("shunt calibrator") was used to cross check the laboratory and flight boxes. Cross calibration was performed only on the flight boxes for Cosmos 1514.
- The U.S.S.R. surgical team was trained and supported by U.S. investigators to ensure proper surgical implantation procedures were conducted since some animals were lost 60-90 days after surgery for the Cosmos 1514 mission.
- For Cosmos 1667 one preflight in-vivo cross calibration and two postflight cross calibrations were conducted. No postflight in-vivo cross calibrations were performed after the Cosmos 1514 mission.
- An onboard reference timer/sequence controller was added to eliminate the potential heart rate discrepancies which existed in the Cosmos 1514 data.
- A U.S. ambient pressure sensor was added on Cosmos 1667. No direct U.S.S.R. pressure measurement was available on Cosmos 1514.
- Data selection (appropriate segments for analysis) was supported by the U.S. investigators, and the significant problems in Cosmos 1514 data selection were circumvented.

Six animals were instrumented for the Cosmos 1667 cardiovascular experiment (Table 3) for which data were collected. Of these, only Gordyy, weighing 4 kg, was flown aboard the spacecraft. Two monkeys, Samurai and Kvak, served as ground-based controls for the flight animal. Tilt tests were performed on these three subjects as well as on three others, Angel, Fronya and Troll.

## 2. Pre-flight Events

CV cuffs were surgically implanted in the six animals in May 1985. Leads were exteriorized several days later. Pre-flight tilt tests were performed on all six animals in late June 1985. Data were collected from tilt, transducer cross calibration, control monitoring and bioengineering tests in the pre-flight period.

### 3. Launch, On-orbit and Re-entry Events

Gordyy was placed in near-earth orbit 63 days after cuff implantation. The cuff provided excellent quality signals for 155 days. Inflight data sampling frequency was for 5 minutes every 2 hours from 0800 to 2400 hours (lights-on), and for 5 minutes every 30 minutes from 2400 to 0800 hours (lights-off). Data collected during flight consisted of carotid flow, carotid pressure, ECG, time code and ambient pressure measurements.

### 4. Post-flight Events

Post-flight tilt tests were performed three days after spaceflight on Gordyy and Samurai. Gordyy, Samurai and Kvak were subjected to a 7-day ground-based synchronous control experiment one month following spaceflight. Tilt tests were carried out again three days after the synchronous control experiment on Gordyy, Samurai and Kvak. Post-flight data were collected from synchronous control, tilt and cross calibration tests.

Data transfer occurred after completion of all post-flight synchronous control experiments. The transfer of analog data from Soviet tape recorders to U.S. tape recorders took place from 30 September 1985 to 23 October 1985 in Moscow. Transfer of the physiologic data to U.S. data acquisition and analysis systems occurred upon return of equipment to Ames Research Center on 6 November, 1985.

## C. U.S. BIOINSTRUMENTATION DEVELOPMENT

### 1. Flight Hardware

The flight and ground support equipment used for the Cardiovascular Experiment is listed in Table 4. The flight data recording configuration, including the CV signal processor ("Unit") is shown schematically in Figure 1. The CV signal processor consisted of blood pressure and velocity transducers, their associated signal conditioners and a control circuit. The signal conditioners were powered by a lithium battery pack since their extreme sensitivity to voltage variations precluded the use of standard spacecraft power. The pressure and velocity transducers were mounted in a common plastic cuff, as diagrammed in Figure 2. It contained two parts: the upper portion of the assembly which contained both pressure and flow transducers; and the lower portion which consisted of several interchangeable shells of different sizes, capable of fitting around vessels ranging from 2.5 to 5.0 mm in diameter. The cuff was constructed of injection molded plastic to ensure that surfaces were smooth and that the upper and lower sections mated closely. The device was surgically placed over the carotid artery. The leads were passed under the skin and exteriorized at the monkey's lower back.

The CV signal processor became activated upon accepting a "start pulse" from the biosatellite on reaching orbit. The CV signal processor data output included carotid blood pressure and flow as well as internal calibration pulses, ambient pressure and a time code. The CV data were recorded on Soviet tape recorders. Soviet flight recorder data were transferred to a U.S. recorder postflight. CV flight hardware elements are shown in Figure 3 and the flight hardware system integration is shown in Figure 4 (see Section II, reference 5). More detailed schematics and photographs of major cardiovascular hardware, along with specifications, are provided in the final report of the experiment flown on Cosmos 1514 (Section II, reference 1).

Barometric pressure was measured using a commercially purchased "Barocel" unit to correct and normalize the implanted pressure sensor to 760 mm Hg. The Barocel unit is shown in Figure 3. The device included a highly accurate diaphragm capacitance transducer and was physically mounted in the capsule during the flight. The signal conditioner for the barometric pressure sensor and the microprocessor timer/controller were physically located in housing labeled "Biorhythm Recorder", used for a different experiment on Cosmos 1514. The Barocel and its associated electronics operated well during the synchronous control experiment, but failed to provide accurate measurements during the last few days of flight. Due to this problem, transducer pressure cell values were corrected using the calculated ambient spacecraft pressure values provided by the Soviet investigators.

## 2. Ground Support Equipment

Equipment of various types was required to support the inflight hardware (Table 4). Custom-made biological signal simulators were used to perform system integration tests when animal subjects could not be present. Test equipment was required for calibrations, diagnosis of system problems, and conducting on-site repairs. Additional equipment was required to support data transfer from U.S.S.R. to U.S. tape recorders.

#### D. REFERENCES

1. Rosenzweig, S.N., K.A. Souza. Final Reports of U.S. Experiments Flown on the Soviet Satellite Cosmos 782. NASA Technical Memorandum 78525, 1976.
2. Rosenzweig, S.N., K.A. Souza. Final Reports of U.S. Experiments Flown on the Soviet Satellite Cosmos 936. NASA Technical Memorandum 78526, 1978.
3. Heinrich, M.R. , K.A. Souza. Final Reports of U.S. Rat Experiments Flown on the Soviet Satellite Cosmos 1129. NASA Technical Memorandum 81289, 1981
4. Mains, R. C., E.W. Gomersall. Final Reports of U.S. Monkey and Rat Experiments Flown of the Soviet Satellite Cosmos 1514. NASA Technical Memorandum 88223, 1986.
5. Ballard, R.W., Connolly, J.P., Grindeland, R.E. Final Reports of the U.S. Experiments Flown on the Soviet Biosatellite Cosmos 1887. NASA Technical Memorandum 102254, 1990.
6. Ballard, R.W., Connolly, J.P., Grindeland, R.E. Final Reports of U.S. Monkey and Rat Experiments Flown on the Soviet Biosatellite Cosmos 2044. NASA Technical Memorandum (in preparation).
7. Sandler H. Cardiovascular Effects of Weightlessness and Ground-Based Simulation. NASA Technical Memorandum 88314, 1988.
8. Sandler H., R. Osaki, E. Agasid, R. MacKenzie, M. Skidmore, and J. Hines. Cosmos 1667: Primate Cardiovascular Experiment Final Science Report, 1986. (Unpublished NASA report).

## E. LIST OF FIGURES AND TABLES, SECTION I

### FIGURES

1. Flight data recording configuration.....9
2. Pressure/flow cuff diagram.....10
3. CV Experiment flight hardware elements .....11
4. CV hardware flight configuration, on the spacecraft .....12

### TABLES

1. Flight parameters for Cosmos biosatellite missions with U.S. participation.13
2. Investigations aboard Cosmos 1667 and related studies.....14
3. Flow diagram of instrumented animals used in Cosmos 1667.....23
4. Cardiovascular Hardware Description.....24

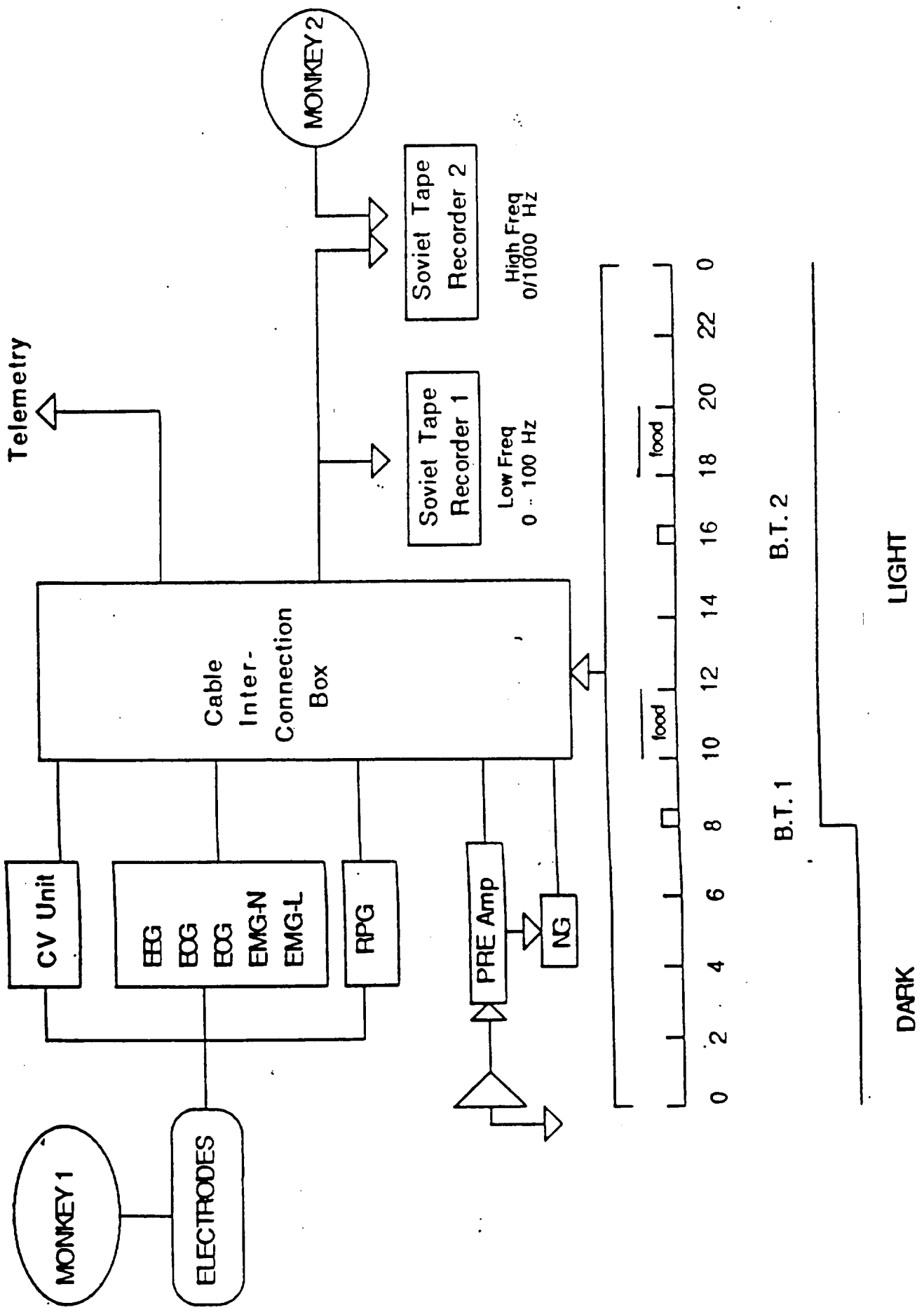
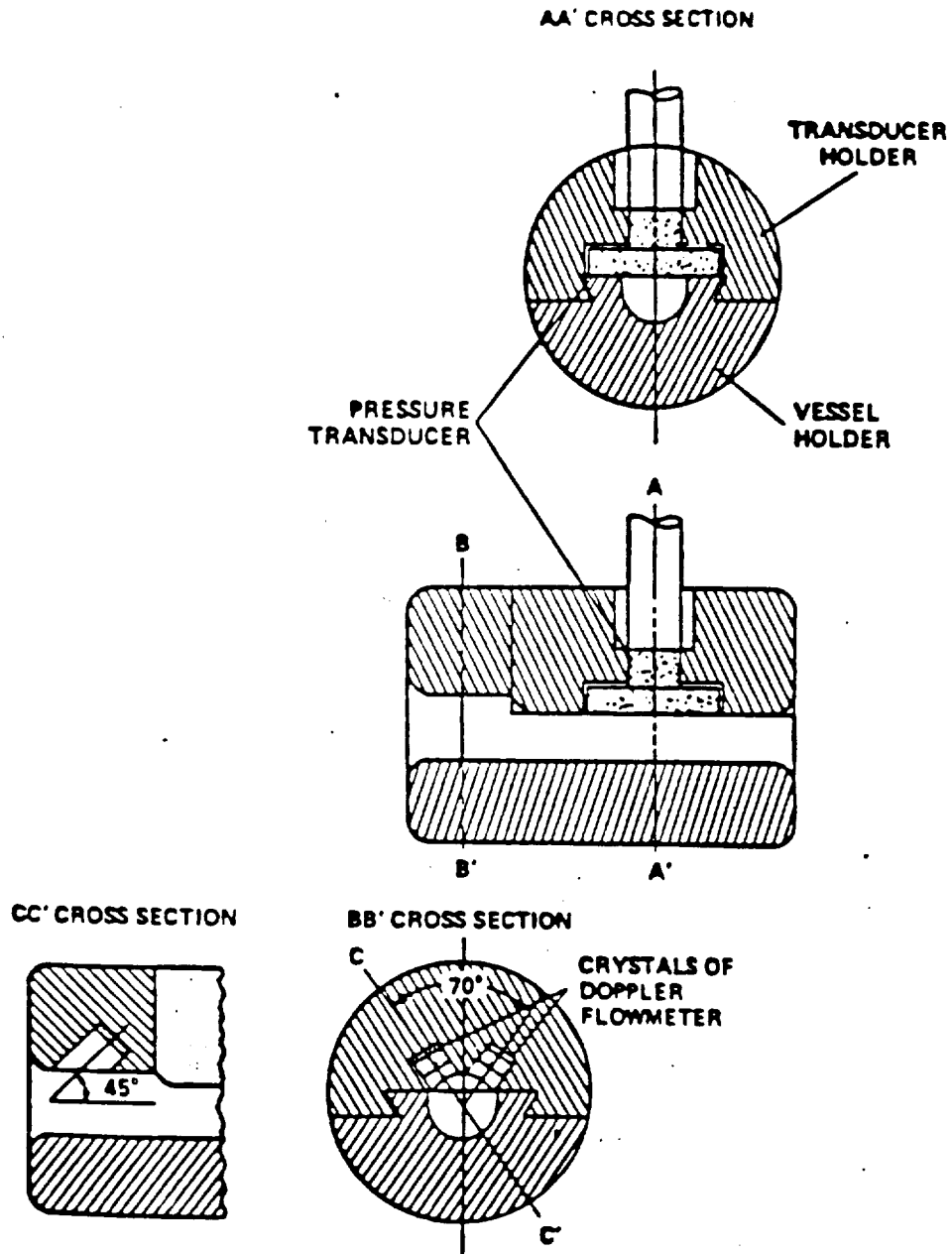

Figure 1. Flight data recording configuration



**CROSS SECTIONAL DIAGRAM**

Figure 2. Pressure/flow cuff diagram



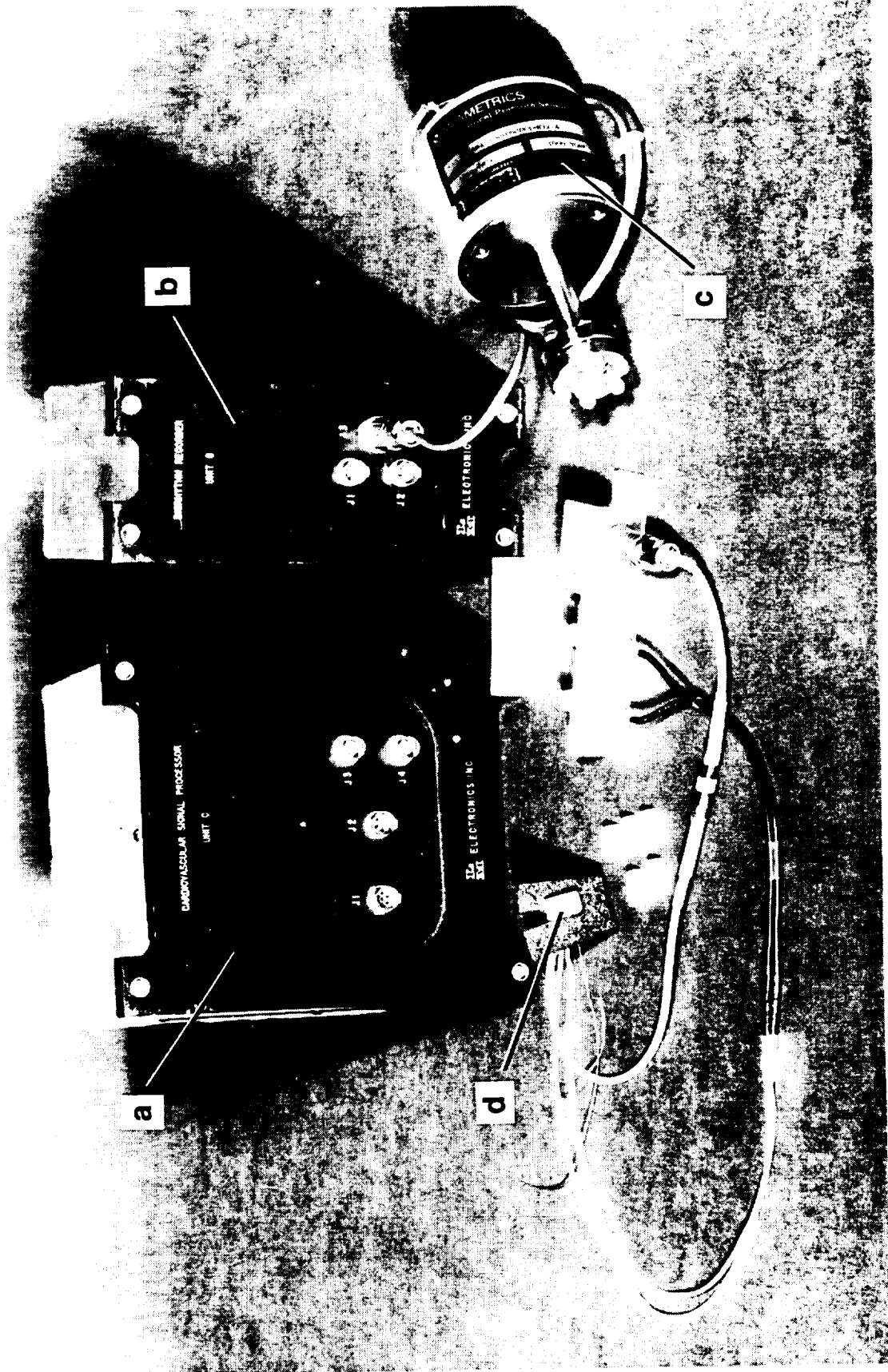

Figure 3. CV experiment hardware elements. (a) CV signal processor; (b) BR recorder box with ambient pressure signal conditioner; (c) Barocel ambient pressure sensor; (d) pressure and flow cuffs.

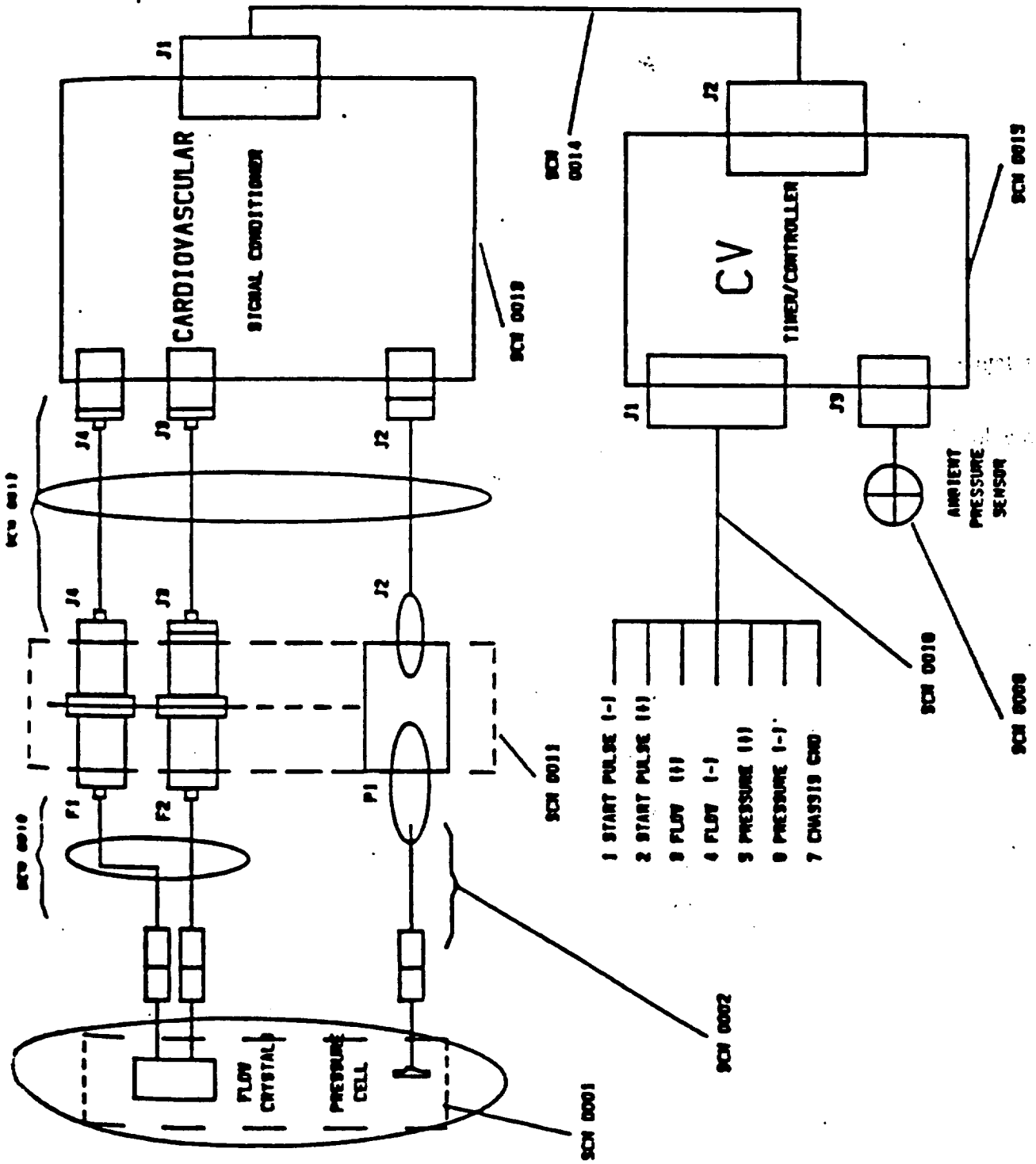

Figure 4. CV flight hardware configuration on the spacecraft

TABLE 1

FLIGHT PARAMETERS FOR COSMOS BIOSATELLITE MISSIONS  
WITH U.S. PARTICIPATION (THROUGH 1985)

PARAMETERS	COSMOS 782	COSMOS 936	COSMOS 1129	COSMOS 1514	COSMOS 1667
Launch	11/25/75	08/03/77	09/25/79	12/14/83	07/10/85
Recovery	12/15/75	08/22/77	10/14/79	12/19/83	07/17/85
Duration (Days)	19.5	18.5	18.5	5.0*	7.0
Orbital Period (Min)	90.5	90.7	90.5	89.3	89.4
Apogee (Km)	405	419	406	288	270
Perigee (Km)	226	224	226	226	211
Inclination (Deg)	62.8	62.8	62.8	82.3**	82.4**

\* Mission duration shortened for first rhesus monkey flight.

\*\* Higher orbital inclination for radiation experiments.

**TABLE 2 INVESTIGATIONS ABOARD COSMOS 1667 AND RELATED STUDIES**

EXPERIMENT	INVESTIGATOR	COUNTRY
<b>Bone (Structure, Metabolism, Biomechanics)</b>		
Histomorphometric analysis of rat bones	A. S. Kaplansky G. N. Durnova Z. F. Sakharova E. I. Ilyina-Kakueva	U.S.S.R.
Effect of microgravity on weight-bearing and non weight-bearing bones of rats in 7-day spaceflight	D. Chappard C. Alexander	France
State of organic components of bones and skin	J. Pospishilova M. Pospishil	Czechoslovakia
Effect of microgravity on the cellular activity of rat bones and assessment of methods of its stimulation	M. Viso	France
Time-course variations of primate bones as indicated by morphological examinations of bone structure	C. Nogues V. E. Novikov	France U.S.S.R.
Mechanical characteristics of rat bones after short-term space flights	A. M. Bakulin E. A. Ilyin V. S. Oganov V. E. Novikov	U.S.S.R.
Effect of 7-day spaceflight on osteocyte activity of male rats	C. Alexander D. Chappard	France
Characterization of rat bone mineralization	A. V. Bakulin V. E. Novikov V. I. Lebedev L. T. Rezaeva Yu. N. Khodkhevich E. M. Artamasova	U.S.S.R.
State of the rat periodontium after short-term space flights	A. I. Volozhin G. V. Amelkina	U.S.S.R.
Effect of weightlessness on rat teeth and jaws	H. Kammel M. Kleber K. Hecht E. Wachtel I. N. Sergeev	GDR U.S.S.R.
Study of the production of osteoclast stimulating factor in Cosmos 1667 rats	A. T. Lesnyak N. V. Boshikov N. P. Rykova I. V. Serov	U.S.S.R.
Morphological evaluation of the state of rat thyroid and parathyroid glands	G. I. Plakhuta -Plakutina N. D. Dmitrieva E. A. Amirkhanyan	U.S.S.R.

EXPERIMENT	INVESTIGATOR	COUNTRY
Rat bone metabolism	I. A. Popova	U.S.S.R.
Time course variations of the mineral content in the primate peripheral skeleton at various preflight stages	A. S. Rachmanov S. L. Dubonos V. E. Novikov Yu. V. Gordeev	U.S.S.R.
Effect of 7-day spaceflight on the bone mass of male rats	D. Chappard C. Alexander	France
<b>Cardiovascular Function in Primates and Rats</b>		
Effect of microgravity on blood pressure and flow in the common carotid artery of primates	V. P. Krotov H. Sandler Yu. A. Evstratov J. Hines A. N. Nazin B. Halpryn E. G. Bazunova B. Benjamin Å. O. Belgorodsky	U.S.S.R. U.S.A.
Central circulation in primates	A. M. Badakva N. V. Miller G.G. Charmuliev	U.S.S.R.
Effect of spaceflight factors on blood circulation in primates	V. I. Lobachik S. V. Abrosimov V. V. Zhidkov D. K. Endeka A. Ya. Kushnerev E. A. Ilyin V. I. Korolkov	U.S.S.R.
Electrocardiographic investigation of the heart function of primates at the acute stage of adaptation to microgravity	V. P. Melnichenko G. G. Chamurliiev Yu. A. Evstratov	U.S.S.R.
Ca-dependent ATPase of myosin in the rat heart	E. A. Nosova	U.S.S.R.
<b>CNS, Sleep and Biorhythms of Primates</b>		
Higher nervous activity and sleep-wakefulness cycles in flown primates	G.G. Shlyk M.A. Shirvinskaya I.B. Koslovskaya V.I. Korolkov M. Ya. Efimova V.S. Magedov V.K. Vasilyev T.G. Urmancheeva G.S. Belkaniya I.P. Sheremet V.M. Eliava C. Milhaud B. Kayes	U.S.S.R. France

EXPERIMENT	INVESTIGATOR	COUNTRY
Minute rhythms in Cosmos 1514 and 1667 primates as a sensitive index of their adaptation	K. Hecht G.G. Shlyk J. Drescher E. Wachtel K. Jevgenov	G.D.R. U.S.S.R.
Analysis of electrographic correlates of sleep in Cosmos 1667 primates	E. Wachtel H. Balzer V.S. Magedov R. Ziems M.A. Shirvinskaya G.G. Shlyk	G.D.R. U.S.S.R.
Biorythms and temperature homeostasis in Cosmos 1667 primates	A.M. Alpatov V. Ya. Klimovitsky V.S. Magedov A.O. Belgorodsky G.G. Chamurlicv	U.S.S.R.
Mathematical programs for an analysis of minute biorhythms in Cosmos 1514 and 1667 primates	K. Jevgenov W.L. Woljak Yu. A. Evstratov V.K. Vasilyev J. Drescher V.S. Magedov H. Balzer	G.D.R. U.S.S.R.
<b>Fluid-Electrolyte Metabolism in Primates and Rats</b>		
Fluid parameters in primates after 7-day spaceflight	V. I. Lobachik V. V. Zhidkov S. V. Abrosimov D. K. Endeka	U.S.S.R.
Diet and metabolic investigations in Cosmos 1667 primates	M. A. Dotsenko R. I. Rudneva E. G. Besedina Yu. V. Gordeev V. I. Lebedev V. I. Korolkov	U.S.S.R.
Effect of short-term weightlessness on the fluid-electrolyte composition of animal tissues	E. A. Lavrova L. A. Denisova Yu. V. Natochin L. V. Serova E. I. Shakhmatova	U.S.S.R.
Content of cyclic nucleotides in the rat kidney	L. M. Kurkina	U.S.S.R.
Comparison of the mineral composition of tissues and organs of male and female rats flown on Cosmos 1514 and 1667	P. Luderitz M. S. Belakovsky D. Markwardt E. Wachtel	G.D.R. U.S.S.R.
Mineral substances and trace elements in the hair of primates and rats after Cosmos 1514 and 1667	P. Luderitz R. I. Rudneva D. Markwardt M. A. Dotsenko	G.D.R. U.S.S.R.

EXPERIMENT	INVESTIGATOR	COUNTRY
<b>Gastrointestinal Tract and Digestive Glands</b>		
Ultrastructural specificities of the pancreas of Cosmos 1667 rats	N.K. Permyakov G.P. Titova N.K. Trusenko	U.S.S.R.
Digestive tract of rats after Cosmos 1667 flight	P. Grozs A. Bordeianu A. Boes	Rumania
Morphological examination of hepatocytes of the flown rats	W. Stodolnik -Baraanska W. Kujawa E.A. Savina	Poland U.S.S.R.
Cytochemistry and ultrastructure of salivary glands of rats exposed to altered gravity	E.A. Shunikova A. V. Ilyicheva	U.S.S.R.
<b>Metabolism and Its Regulation</b>		
Comparative characterization of homeostatic reactions of rat blood during Cosmos flights	I. A. Popova B. F. Afnonin E. G. Vetrova T. E. Drozdova E. A. Zagorskaya I. M. Larina E. N. Kabitsky A. A. Markin	U.S.S.R.
Changes in the activity of the neuroendocrine system and adrenergic receptors in Cosmos 1667	R. Kvetniansky T. Torda M. Vygás P. Vlajacik	Czechoslovakia
Spaceflight effect on metabolic regulation in the liver	L. Maho C. Nemeth M. Vygás S. Zorad G. Svaboval	Czechoslovakia
Changes in deoxyribonucleoproteins and nucleic acids in certain rat tissues	E. Mishurova J. Gabor D. Pado	Czechoslovakia
Replication in rat liver nuclei after Cosmos 1667 flight	G. S. Komolova A. V. Zakaznov I. A. Egorov	U.S.S.R.
RNA polymerase activity in the rat liver after Cosmos 1667 flight	V. F. Makeeva I. A. Egorov G. S. Komolova	U.S.S.R.
Red blood metabolism in Cosmos 1667 flight and synchronous control rats	S. M. Ivanova S.S. Brantova O. I. Labetskaya A. S. Ushakov	U.S.S.R.
Tissue lipids in rats after short-term spaceflight	I. Alers E. Alersova	Czechoslovakia

EXPERIMENT	INVESTIGATOR	COUNTRY
State of lipid peroxidation and antioxidation protection enzymes after 7-day spaceflight	I. A. Popova N. V. Delenyan A. A. Markin	U.S.S.R.
<b>Morphology of the Central Nervous System of Rats</b>		
Morphology and cytochemistry of the nervous system of weightless rats	I. B. Krasnov	U.S.S.R.
Morphometric analysis of the central cerebellar lobule cortex of Cosmos 1667 rats	M. Bouteille	France
Ultrastructure of the cerebral cortex of rats after 7-day exposure to weightlessness	L. N. Dyachkova	U.S.S.R.
Morphometric analysis of brain stem neurons of Cosmos 1667 rats	T. A. Leontovich P. V. Belichenko	U.S.S.R.
Morphometric analysis of the vessels of the cerebellar hemisphere of rats	I. G. Lyudkovskaya B. M. Morgunov	U.S.S.R.
<b>Physiological and Morphological Studies of Vestibular Apparatus and Vestibulo-Oculomotor Interaction</b>		
Evolution of studies of the vestibulo-oculomotor interaction of microgravity using the gaze fixation reaction	I. B. Kozlovskaya M. G. Sirota B. M. Babaev I. N. Beloozerova A. M. Ivanov A. N. Nyrova S. B. Yakushin G. G. Shlyk M. A. Shirvinskaya	U.S.S.R.
Protocol of a chronic neurophysiological experiment	M. G. Sirota B. M. Babaev I. N. Beloozerova I. B. Koslovskaya A. N. Nyrova S. B. Yakushin	U.S.S.R.
Study of the neuronal activity of vestibular nuclei in real weightlessness	M. G. Sirota B. M. Babaev I. N. Beloozerova A. M. Ivanov I. B. Koslovskaya A. N. Nyrova S. B. Yakushin	U.S.S.R.
Morphological investigations of the rat labyrinth	D. V. Lychakov V. F. Anichin A. N. Pashchinin Ya. A. Vinnikov E. A. Savina	U.S.S.R.
Morphology and cytochemistry of vestibular structures of the brain of rats exposed to altered gravity	I. B. Krasnov	U.S.S.R.



EXPERIMENT	INVESTIGATOR	COUNTRY
<b>Problems of General Biology</b>		
Biological investigations on Cosmos 1667	G. P. Parfyonov M. G. Tairbekov	U.S.S.R.
Energy exchange of insects in microgravity	M. G. Tairbekov G. P. Parfyonov A. V. Smirnova A. V. Devyatko	U.S.S.R.
Effect of spaceflight factors on intergenic recombination of <i>Drosophila</i>	L. P. Filatova N. T. Lapteva N. P. Grozdova	U.S.S.R.
Regeneration of organs and tissues in amphibians in microgravity	E. M. Cherdantseva V. I. Mitashev E. P. Grigoryan S. Ya. Tuchkova	U.S.S.R.
Multiplication of <i>Tetrahymena periformis</i> culture in spaceflight	I. S. Irlina A. V. Gabova I. B. Ravkov M. G. Tairbekov	U.S.S.R.
Morpho-functional characteristics of plants in microgravity	M. G. Tairbekov E. I. Khesina D. A. Sadekova	U.S.S.R.
Structural organization of cells of the root meristem of maize seedlings formed in microgravity	V. G. Grif E. M. Barmicheva V. P. Zhvalikov -skaya M. G. Tairbekov	U.S.S.R.
Growth and morphology of lettuce sprouts in microgravity	A. I. Merkis R. S. Laurinavicius	U.S.S.R.
Chemical composition of plant cell walls in microgravity	V. V. Lozovaya O. A. Zabolina G. S. Grozdovskaya M. G. Tairbekov	U.S.S.R.
Changes in the cell proliferation rate under the influence of spaceflight effects	H. Planel	France
Cell differentiation and proliferation of roots of maize plants cultivated in microgravity	N. Dambelley	France
<b>Reproductive Function of Rats</b>		
Microgravity effect on the reproductive system of rats- main results and further studies	L. V. Serova	U.S.S.R.
Possible methodical approaches to the evaluation of the reproductive function of rats in spaceflight	W. Stodolnik -Baranska	Poland
Cytological characterization of testes of the flown rats	G. P. Tikhonova L. A. Denisova Yu. V. Ivanov	U.S.S.R.

EXPERIMENT	INVESTIGATOR	COUNTRY
Content of water and electrolytes in testes of the flown rats	L. A. Denisova E. A. Lavrova E. I. Shakhmatova	U.S.S.R.
Reproductive function of male rats and the state of their progeny	A.M. Pustynnikova O. V. Baikova	U.S.S.R.
Central nervous system of the progeny of the male rats flown on the biosatellite: rate of development and status	Z. I. Apanasenko V. Yu. Korotkova	U.S.S.R.
Electronic investigation of synaptonemic complexes of the flown rats	T. F. Mazurova O. L. Kolomiets Yu. F. Bogdanov	U.S.S.R.
Device for obtaining spermatozooids of rats by electroejaculation	Wranska, I. G. G. I. Sotirov T. P. Pantev I. T. Nikolov	Bulgaria
<b>Skeletal Muscles (Structure, Metabolism, Contraction)</b>		
Morphological examination of rat skeletal muscles	E. I. Ilyina-Kakueva	U.S.S.R.
Structural and functional reactions of rat skeletal muscles after Cosmos 1667 flight	D. Desplanches G. Maye M. Grandmontagne R. Flandrez	France
Changes in the ultrastructure of smooth muscles and neuromuscular synapses under the influence of spaceflight factors	O. M. Pozdnyakov L. L. Babakova M. S. Demorzhi E. I. Ilyina-Kakueva	U.S.S.R.
Cation distribution in muscles and activity of cation-dependent transport systems	V. P. Nesterov N. N. Dyomin V. K. Shmelev E. H. Safaryan	U.S.S.R.
Muscle proteins: content and enzyme activity in long- and short-term spaceflight	L. M. Kurkina I. A. Popova	U.S.S.R.
Effect of microgravity on the motor control system in primates	M.G. Sirota I.N. Beloozerova B.M. Babaev S.B. Yakushin A.N. Nyrova G.G. Shiyk M.A. Shirvinskaya I.B. Kozlovakaya	U.S.S.R.
Functional adaptation of rat skeletal muscle in short-term spaceflight	S.A. Skuratova V.S. Oganov L.M. Murashko M.A. Shirvinskaya A. Szoor M. Rapesak	U.S.S.R., Hungary
Rate of glycolysis in rat skeletal muscles and liver	S.M. Ivanova O.I. Labetskaya	U.S.S.R.

EXPERIMENT	INVESTIGATOR	COUNTRY
Protein content and enzyme activity in muscles	L.M. Kurkina E.G. Vetrova T.E. Drozdova I.V. Zaolotskaya	U.S.S.R.
Properties of glycogen phosphorylase and kinase phosphorylase in muscles	V.P. Nesterov I.N. Dyomin G.P. Serebrennikova M.V. Mikhailova	U.S.S.R.
Contraction properties of different muscles in Cosmos 1514 and 1667 experiments	M. Rapesak A. Szoor S.A. Skuratova L.M. Murashko	Hungary, U.S.S.R.
Effect of microgravity and hypokinesia on phasic movements of primates	M.G. Sirota T.G. Urmancheeva I.N. Beloozerova A.A. Djookua A.M. Ivanov G.G. Shlyk M.A. Shirvinskaya	U.S.S.R.
Change in the tonic components of movements of primates in microgravity and hypokinesia	M.G. Sirota T.G. Urmancheeva I.N. Beloozerova V.M. Eliava	U.S.S.R.
Change of contraction of rat myofibers after Cosmos 1667 flight	S.A. Skuratova L.M. Murashko V.S. Oganov	U.S.S.R.
Adaptation of various skeletal muscles to weightlessness in Cosmos 1667 flight	O. Tacacs M. Rapesak T. Szilagyí A. Szoor F. Guba V.S. Oganov	Hungary, U.S.S.R.
Effect of microgravity on contraction properties and sarcoplasmic reticulum of rat skeletal muscles	Y. Noumier C. Holy	France
<b>Stress</b>		
Morphological examination of the adrenal cortex of Cosmos 1667 rats	W. Stodolnik-Baranska M. Kujawa N.G. Prodan	Poland, U.S.S.R.
Comparative histological examination of lymphoid organs of rats after 7- and 20-day flights	G.N. Dumova E.V. Vorotnikova	U.S.S.R.

EXPERIMENT	INVESTIGATOR	COUNTRY
Changes in hemopoietic stem cells in male rats	A. Vacek T.V. Michurina L.V. Serova D. Rotkovska L. Domoraska O.N. Pryanichnikova A. Bartonickova N.G Khrushchov	Czechoslovakia, U.S.S.R.
Study of cell mediated immunity and antiviral resistance of rats	I.V. Konstantinova A.F. Lesnyak M.P. Rykova N.V. Bozhikov I.V. Serov E.P. Gotovtseva	U.S.S.R.
Morphometric examination of the rat adrenal medulla	N.G. Prodan	U.S.S.R.
Morphological examination of the rat adenopituitary	E.I. Alekseev	U.S.S.R.
Cytological investigation of the rat peripheral blood and bone marrow	N.A. Chelnaya	U.S.S.R.

TABLE 3 FLOW DIAGRAM OF INSTRUMENTED ANIMALS USED IN COSMOS 1667

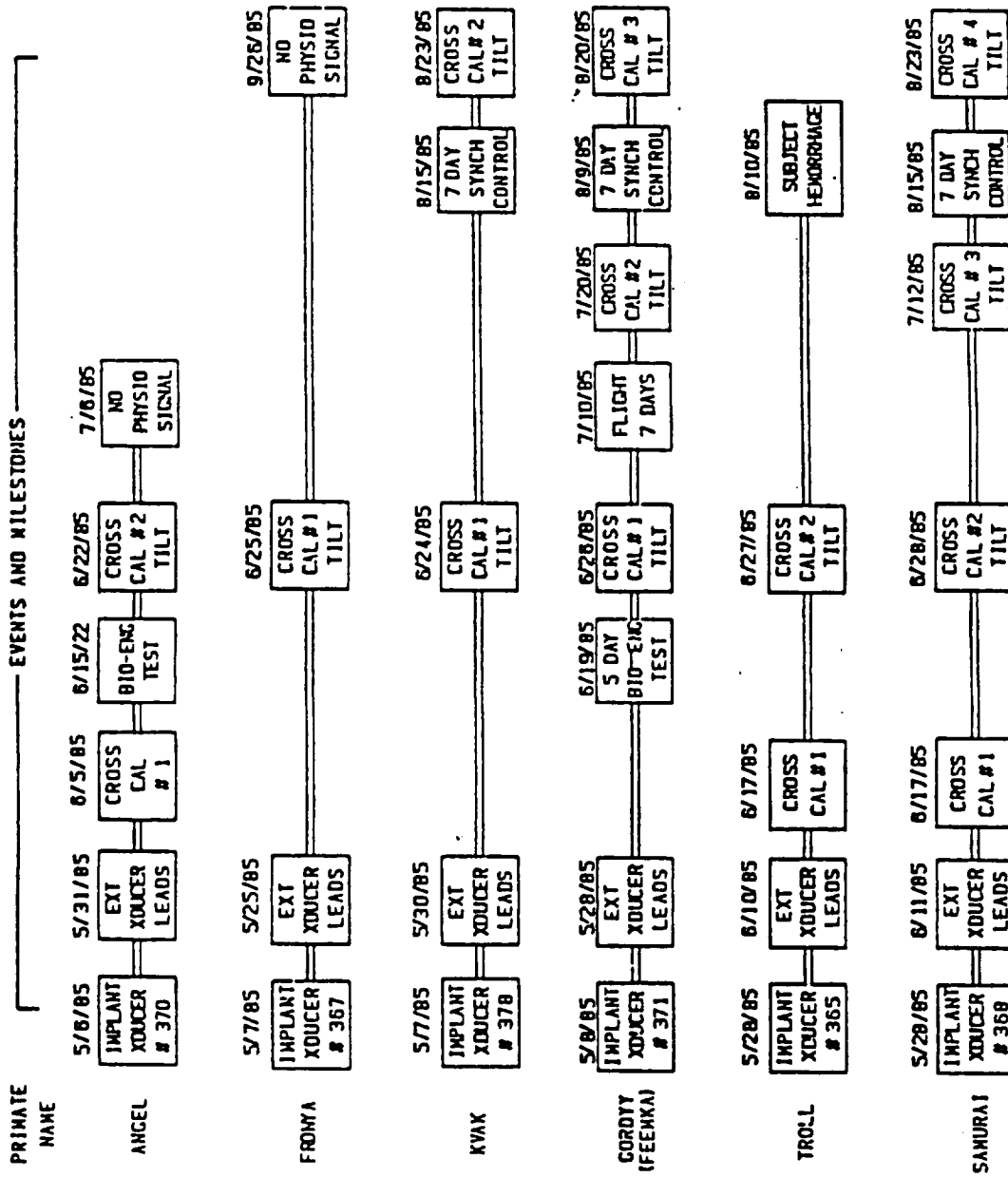

TABLE 4  
CARDIOVASCULAR HARDWARE DESCRIPTION

HARDWARE TYPE	ITEM
Flight (8 sets for U.S.S.R. use)	CV signal processor (includes timer/controller, pressure and flow signal conditioners) Ambient pressure signal conditioner Ambient pressure sensors Combined pressure/flow cuffs Interconnection cables and boxes
Ground equipmt. (4 sets for U.S.S.R. use)	Battery pack tester Signal simulator Battery pack spares 220/110 V transformer
Test equipment (1 set for U.S.S.R. use)	Pressure sensor calibration system Flow sensor calibration system
Support equipment (1 set for U.S. use)	Spare parts kit Tools Data transfer (tape recorder, time code generator, cables, connectors, etc.) Interference test (spectrum analyzer, frequency generator, etc.) Cross calibration (L & M 1012, 2007 signal conditioners, etc.) Rechargeable/switchable power supply

## II. PRIMATE CARDIOVASCULAR FLIGHT EXPERIMENT AND GROUND BASED CONTROLS

Cardiovascular Research Laboratory  
Ames Research Center  
Moffett Field, California

Institute of Biomedical Problems  
Moscow, U.S.S.R.

U.S. Principal Investigator:

H. Sandler, MD  
Chief, Cardiovascular Research Office

Co- Investigators:

M. Skidmore  
Test Facility Operation Manager

J. Hines, MSEE  
Major, USAF, Cosmos Payload Mgr

R. Osaki  
Programmer Analyst, MATSCO\*

E. Agasid  
Engineering Specialist, MATSCO\*

R. MacKenzie  
Technical Support, MATSCO\*

U.S.S.R. Principal Investigator:

V.P. Krotov

Co- Investigators:

E.G. Bazunova

A. O Belgorodsky

Yu. A. Estratov

A.N. Nazin

\* Management and Technical Services Company

## A. INTRODUCTION

Results of the Cosmos 1514 primate Cardiovascular Experiment indicated that significant cardiovascular changes occur during spaceflight. The study conducted aboard Cosmos 1667 supports this conclusion. The changes appear to be triggered by a headward shift in blood and tissue fluid volume. These adaptive changes would enable maintenance of adequate oxygen delivery to the brain. Longer-term exposure to weightlessness would result in further changes which serve to better adapt the animal to a hypo-metabolic state.

## B. METHODS

### 1. Animal Training

Flight candidate animals began training at the Sukhumi primate facility about 1.5 years preflight. Subjects underwent clinical and behavioral screening, initial training, and tail removal to fit the flight couch before arriving in Moscow. General training included operation of paste food and juice bite-switches, launch/recovery g load simulation, and training to flight couch confinement, isolation and other environmental factors. Special training consisted of behavioral tasks related to vestibular tests conducted in lab-prototype and flight-like systems.

### 2. Sensor Implantation

Vestibular head plates were attached to all of the 14 animals in the flight candidate pool beginning in April 1985. One-half of the subjects received CV pressure and flow sensor implants and a respiration sensor. The leads were exteriorized approximately 20 days later, and Soviet EKG, EOG and rheoplethysmography leads were implanted. The other half of the flight candidate pool received various brain electrode implants (1).

### 3. Selection of Flight Animals

Final selection was conducted after a 3-4 day flight simulation test of all candidates in a primate "BIOS" mock-up. The test provided additional subject training, preflight control data and an evaluation of overall subject performance. Final flight candidates and back-ups were sent to the launch site, where metabolic tests and clinical evaluations were conducted. After the two flight monkeys were placed in the flight BIOS couch, the final brain electrode placements were made in the vestibular nuclei of both animals. A complete systems test was performed before launch.

### 4. Delayed Synchronous Control Study

The synchronous control study was conducted in Moscow one month following flight, on the flight subjects. The preflight BIOS mock-up was used with a timeline identical to that of flight.

### 5. Vivarium Control Study

Data collected from animals housed in normal laboratory conditions were used to compare with flight data and to verify hardware function and experiment protocols.



## 6. Tilt Tests

The flight and back-up animals, as well as the other animals were subjected to preflight and postflight tilt tests as listed in Figure I-A (2). Animals were lightly anesthetized with Valium (2 mg/kg) prior to testing to avoid possible physiological changes induced with more potent anesthetic agents. Each tilt test had an overall duration of 37 minutes. The test animals were exposed to the following changes in body position while lying supine on a tilt table:

Level 1	5 minutes horizontal (0°) control
Level 2	6 minutes head-up (+70°) tilt
Level 3	5 minutes head-down (-70°) tilt
Level 4	5 minutes horizontal (0°)
Level 5	5 minutes head-down (-70°) tilt
Level 6	6 minutes head-up (+70°) tilt
Level 7	5 minutes horizontal (0°) recovery

At the completion of each tilt test the animals were kept in a horizontal (0°) body position for 30 minutes, for recovery. They were then given 0.2 mg/kg Metacin, a parasympathetic nervous system blocking agent, and observed for an additional 30 minutes in order to study resting hemodynamic changes. Results of Metacin use are not included in this report.

## 7. Cross Calibration of CV transducers

For the 1667 spaceflight, new procedures to cross calibrate the pressure transducers were required due to the following factors:

- The CV pressure and flow transducers were subject to drift over time and could not be directly calibrated after surgical implantation.
- As the pressure transducers measure absolute pressure, the output would fluctuate with variations in either spacecraft or laboratory ambient pressure.
- Due to limited availability of the flight hardware the majority of ground-based procedures utilized lab equipment in place of the flight hardware.

Accordingly, a procedure for in-vivo calibration was developed to correct for transducer drift and fluctuations in atmospheric pressure, and an in-vitro transfer standard was developed to cross reference the various pieces of pressure sensor signal conditioning hardware.

The in-vivo procedure involved inserting a needle attached to a calibrated pressure transducer (Aitec™ brand pressure transducer) into the subject's femoral artery. Mean arterial pressure was derived from the resultant wave form. The subject's cardiovascular system then was challenged by drug infusion in order to elevate the mean arterial pressure. As systemic mean arterial pressure in a reclining subject was essentially equivalent, for the femoral and carotid arteries, simultaneous measurements from the femoral artery and the CV cuff allowed a cross calibration of cuff measured pressure values. A detailed calibration procedure, including use of mathematical linear regression techniques to correlate femoral and cuff measurements, was developed and utilized for all calibrations (3, 5).

The in-vitro transfer standard consisted of a precision resistor network "shunt resistor" that could be connected to all pressure measurement equipment used for these studies. As the flight pressure sensor signal conditioning equipment was functionally and operationally identical to the lab pressure sensor signal conditioning equipment it was possible to

characterize and normalize these devices through the use of the "shunt resistor". The resulting cross reference values were referred to as "calibration shunt levels".

### C. DATA ANALYSIS

Information from ECG, head position, neck muscle activity and pneumocardiography data obtained from Soviet investigators was used to screen the carotid flow and pressure measurements collected during flight. Only data representing a resting physiologic state were chosen for analysis. Acceptable data "sample windows" of 1-2 minutes in length were obtained during lights-on periods. The entire 5 minute data recording window could often be analyzed during the lights-off periods. All selected windows were then broken into sub-intervals containing 20 heart beat segments (BS).

Consecutive sub-intervals of 20 beats each were partitioned from the data ranges selected by the Soviet co-investigators. These 20 BS were determined by examining the ECG signal and locating each occurrence of an R-wave. The pressure and flow signals were then processed for the local minima and maxima that occur during systole and diastole. The basic trend detection method for locating the onset of a pressure or flow waveform used a least-squares approximation of the first derivative. This method has the advantage of filtering out small variances in the signal due to noise and movement. After the pre-onset point of each waveform was located, a sliding 5 point mean was used to locate the local maxima. The arithmetic mean of each signal was calculated for each beat.

For each 20 BS, the mean of all 20 flow and pressure minima, maxima, and peripheral resistance values were determined. All of the 20 BS for each event in the flight and synchronous control experiments were averaged to yield the systolic, diastolic, mean pressure, maximum, minimum, mean flow, peripheral resistance, and heart rate for the segment.

The pre-ejection period (PEP), measured as time in milliseconds from the peak of the R-wave of the ECG to onset of the rise of the leading edge of the carotid pressure waveform, was used as a measure of pulse transit time. Average values for 20 BS were determined for all data.

All data obtained for a specific 5 or 6 minute tilt level event were selected to allow an overview of the entire event on the monitoring screen and to eliminate areas of obvious head or body motion. Pressure and flow signals were also monitored via computer for significant displacement of flow baselines. The resulting data were then divided by the monitoring program into discrete 20 BS. The 20 BS most closely representing the mean values for heart rate, pressure and flow for each tilt level was chosen by the program.

Flight data were statistically analyzed for daily differences (compared to the ground-based experiment with the same monkey), as well as for daily mean changes and day/night variation. Statistical comparisons were conducted using an analysis of variance (ANOVA) with multiple factors. P values with differences of  $p < 0.05$ , or less, were considered significant. Comparisons of continuous Flight and Ground Control data for the flight monkey "Gordyy", are shown in Figures II-A to H. This same data for Gordyy is expressed as daily means +/- standard error, with statistical differences noted at the  $P < 0.05$  and 0.01 level in Figures II-I to P.

Six-day postflight synchronous control studies were conducted 15 August to 22 August 1985, using the animals "Samurai" and "Kvak". Comparisons of data for Samurai with postflight control data from Gordyy are shown in Figures IV-A to AF. Tilt test data for these all monkeys are shown and compared in Figures V-A through U.

The following problems were encountered in analyzing the final data sets and corrective actions were taken as described:

- Calibration shunt levels were not available for either of the flight boxes used for the Synchronous Ground-Based Experiments (SGBE) or for the L & M 2007 lab boxes used during the cross-calibration procedures. This presented problems in assigning highly quantitative values to the derived data. This was handled by using the 2007 high and low cal pulses as the transfer reference to the flight box cal pulses. This assumes an ideal transducer, and as a result the first available stick would theoretically provide the most accurate results. In the case of Samurai, the three successful sticks were applied to the flight box data. Each gave significantly different results. The calibrated readings for the systolic and diastolic CAP from approximately midnight of the days out and three of the test period are provided in the comparative Table 1. Clearly, the initial cross calibration provides the most consistently acceptable results. In Kvak's case, only one calibrated Ailtech stick was available. Fortunately, this was the Pre-Flight stick. When applied to Kvak's SGBE data it also produced acceptable results.

For each stick, a linear regression was performed relating the Ailtech reference of mmHg to the CAP channel. During digitization, the CAP is acquired in values ranging from 0 to 1023. By determining the transfer function for converting these unrelated units to mmHg, the equivalent value of the 2007 cal pulses can be determined by applying the equation to the digital values acquired during the high and low cal pulses. After determining the physiologic equivalent of the 0 and 1 volt pulses, the physiologic equivalents were determined for one volt electrical steps from -2 to 3 volts. This regression line is derived from each stick by using the high and low 2007 cal pulses as 1 and 0 volts, respectively. In this frame of reference, the flight box cals are equivalent to 0 and -2 volts. The complete results of this numerical analysis is provided as the first set of tables in Appendixes B and C for Samurai and Kvak, respectively in the Final Science Report for this experiment (6).

- Although the lack of shunt levels meant that the sticks could not all be related, they were still valid within their own data sets. In other words, they were successfully used to calibrate the tilt studies conducted immediately before the stick. The only time this was not possible was during Kvak's Synchronous Control Tilt - the stick performed during this procedure was not provided with Ailtech calibrations. Therefore, in order to calibrate the pressure data from Kvak's Synchronous Tilt it was necessary to use the only available stick (Pre-Flight) which had been performed two months earlier. In general this means that highly quantitative comparisons cannot be made from animal to animal in the same study, or for animals across studies. It does mean that highly quantitative results are available during the conduct of a given study. This conclusion assumes that the major problem is a zero offset rather than a gain change.

- The data collected from Kvak's flow transducer were subject to frequent dropouts. These dropouts did not effect the pressure or ECG signals, and as a result, several of Kvak's SGBE data events are provided with pressure and heart rate information but without flow data.

Figure I-A contains a flowchart diagram for all animals instrumented and tested during this experiment, designating the type of test performed and a date. This report provides data only from tests on the animals Kvak, Samurai and Gordyy (name for Feemka, after flight).

## D. RESULTS

### 1. Comparison of Synchronous Experiment and Flight Data for Gordyy

Graphs comparing the daily changes between the Synchronous Ground Based Experiment (SGBE), and flight for Gordyy are given in Figures II-A through II-H. Included are changes in heart rate; systolic, diastolic and mean blood pressure; maximal, minimal and mean carotid blood flow velocity; and carotid peripheral arterial resistance. Since launch occurred at 0730 hours on 10 July 1985, the first day of flight was considered to be from 0800 hours on 10 July to 0800 hours on 11 July. All data were subsequently formatted and calculated on this basis for a 24 hour period. Ground based data were handled identical to flight data. The average (mean +/- standard error) daily change for a given variable was then calculated in order to compare SGBE and flight events. Average calculated daily values for each event (heart rate, pressure and flow) for the 6 days of flight are shown in Figures II-I through II-P. Statistical differences between flight and ground, using an Analysis of Variance (ANOVA) are indicated by a single asterisk when  $p < 0.05$ , and by a double asterisk when  $p < 0.01$ .

#### a. Heart Rate

The time course of heart rate change (Figures II-A and II-I) demonstrated expected day/night variations, with mean values decreasing significantly ( $p < 0.01$ ) by flight day 5 compared to Day 1. No such significant change occurred over the course of the SGBE. Mean daily values (Figure II-I) were consistently higher during the SGBE and were markedly different on days 2, 3, and 5. These changes were interpreted to indicate either a decrease in sympathetic tone; an increase in parasympathetic tone; a Starling effect change induced by a headward fluid shift which enlarges the heart, leading to delivery of the same cardiac output at a greater stroke volume; or an in-flight adaptive change in cardiac output in response to a weightlessness induced hypodynamic and/or hypometabolic state.

#### b. Blood Pressure

Blood pressure changes are shown in Figures II-B through D and II-J through L. Systolic pressure tended to increase over the duration of flight compared to SGBE (Figure II-B) and diastolic pressure to be lower (Figures II-C and II-K), being significantly so on Days 1 and 2 of flight. This resulted in mean blood pressure changes (Figure II-L) which showed little difference between the two experiments except on Days 1 and 5. Systolic pressure increased in a regular and consistent fashion over the flight and was significantly different from the SGBE ( $p < 0.01$ ) by day 5. The reasons for the increased pressures remain unexplained, but may reflect changes associated with an increased Starling effect (stroke volume) associated with a headward fluid shift during flight. Changes may also reflect an autoregulatory response to maintain adequate cerebral perfusion over the course of the mission.

### c. Carotid Blood Flow Velocity

Figures II-E through G and II-M through O contain data on carotid blood flow velocity changes during flight and the SGBE. Mean carotid blood flow velocity was significantly lower ( $p < 0.01$ ) over the entire course of spaceflight compared to the SGBE. This was the result of consistently lower diastolic flow rates (Figure II-N) and inability to generate as great a maximal flow. It is of note (Figure II-E) that maximal flow during flight was consistently lower than SGBE, but particularly during the day on Days 3, 4 and 5. Values equalized, or reached, SGBE values during the lights-off period (2400 to 0800 hours) in these cases. The reasons for these changes remain unexplained. The known headward fluid shifts may have acted to increase resistance to flow in these cases. The increased observed pressure changes are consistent with findings of a lowered flow, with compensatory reaction through autoregulatory changes.

### d. Carotid Peripheral Vascular Resistance

The most striking finding for the study was the marked difference for changes in peripheral vascular resistance between flight and the SGBE. Mean values (Figure II-P) were significantly greater ( $p < 0.01$ ) over the entire flight duration. Daily variations (Figure II-H) showed markedly large swings during flight which were twice to three times greater than those observed during the SGBE. Changes during Day 1 of the flight were similar to the SGBE with findings diverging rapidly thereafter, becoming 50% greater on flight Day 2. These changes are interpreted to indicate a significant increase in sympathetic vascular tone during flight. The exact mechanism causing the changes was not identified, but may be due to the increased headward shift of body and tissue fluids caused by weightlessness. The increased resistance persisted over the entire flight and showed no signs of abating by the last day of the mission.

## 2. Comparison of Day/Night Variations

Daily mean variations of various parameters, as given in Figures II-I through II-P were further subdivided into their specific day and night time components (Figures III-A through III-H). The day time during flight and the SGBE was the period from 0800 to 2400 hours (lights-on) and night time was the period 2400 to 0800 hours (lights-off). This analysis was conducted to possibly identify additional explanations for the changes seen to occur with flight.

### a. Heart Rate

Average daily values during the night (solid circles) are compared to day time levels (open circles) for both flight and the SGBE in Figure III-A. Night time values tended to be lower in most cases. During the SGBE, night time values were significantly lower on Day 3 ( $p < 0.01$ ) and Day 4 ( $p < 0.05$ ). During flight such differences occurred on Days 2, 3 and 5 ( $p < 0.01$ ). In all cases, except Day 4, night time values during flight were significantly lower ( $p < 0.01$ ) than during the SGBE. These variations of cardiac rhythm over the course of the flight would support the conclusion of increasing and decreasing sympathetic tone as the most plausible explanation for the observed findings. In flight, or immediate post-flight, tests with pharmacologic agents should be conducted in the future to provide definitive information as to the major role of sympathetic versus parasympathetic, nervous system factors. Simultaneously recorded neurophysiologic data obtained by co-

investigators may also shed light on possible changes in these control systems from vestibular nerve recordings and/or EEGs.

#### b. Blood Pressure

Day/night variations for systolic, diastolic and mean carotid pressures are shown in Figures III-B through III-D. In all cases expected circadian variations occurred. During the SGBE night time, systolic pressure significantly exceeded day time values on Days 1, 4, 5 and 6, with similar changes for diastolic blood pressure on Day 4 and mean blood pressure on Days 1, 4, 5 and 6. Such variations were much more prominent during flight and exceeded SGBE changes. Night time values again exceeded daytime levels and did so significantly for systolic blood pressure elevations became quite prominent on Days 1,3, and 5; for diastolic blood pressure on Days 1, 3, and 5; and for mean pressure on Days 1,3,5 and 6. As shown in Figure III-B, night time systolic blood pressure elevations became quite prominent on Days 3 and 5 of flight. This resulted in much higher mean blood pressures on these occasions. These changes again indicate the presence of significantly increased vascular tone during flight, probably mediated through increased sympathetic nervous system activity. The prominence of these changes during the night time (sleep) period may again have been compensatory for decreased blood flow that took place during this period.

#### c. Blood Flow Velocity

Day/night changes in carotid blood flow velocity are shown in Figures III-E through III-G. Maximal flow tended to be higher during the night, during flight and the SGBE, without showing significant changes in minimal flow. This resulted in higher mean flows during the night time, which was particularly the case during the SGBE. This reaction was blunted during the flight. The lowered blood flow occurring during flight remains unexplained and may have been related to the increased headward fluid shift occurring during weightlessness. Such decreases in blood flow were shown to occur with head down (-70°) tilt in subsequent tests (6). The regular decrease seen in all test animals (Figure V-U) was not observed in Gordyy postflight and may indicate flight induced adaptive changes in this regard, on return to Earth.

#### d. Peripheral Vascular Resistance

Changes are shown in Figure III-H. Day/night differences were not present during the SGBE except on Day 3 (lower during the night). On the other hand significant day/night variations were present during flight, with most values higher during Days 3 and 5 and lower on Days 4 and 6. These changes clearly indicate the presence of altered central nervous system control (probably cyclic changes in sympathetic nervous system tone).

In summary, these overall findings demonstrate that marked and significant hemodynamic changes occurred for the flight animal during weightlessness which were not present during exposure to identical environmental and psychological conditions, while on the Earth. Most prominent was a significant increase in carotid peripheral vascular resistance which resulted from a slight and regular increase in blood pressure over the course of the flight and significantly lower carotid blood flow. Heart rate also showed lower values over the period of observation during flight.

These changes are best explained as compensatory (adaptive) to the headward shift of fluid, regularly seen with weightlessness. It would be expected that a headward tilt in fluid would

result in the alterations seen and were demonstrated to be the case in subsequent tilt studies (6).

Evidence of lower heart rate and altered peripheral vascular resistance (Figures II-A and II-H) also provide important indirect evidence of a central nervous system change during flight. This is best explained by an increased sympathetic tone which varies markedly over the day and flight duration. Changes had not reached a level of equilibrium by flight termination in the present experiment, or in the previous Cosmos 1514 flight. Some of the observed changes (decreased heart rate and blood flow) may also be adaptive changes to the hypodynamic and hypometabolic state of weightlessness. Altered day/night patterns during flight, with marked episodes of relative bradycardia, on Day 5, and increased vascular resistance, may indicate a heightened state of parasympathetic outflow, or marked withdrawal of sympathetic tone.

Observed changes could also be indicative of altered cerebral metabolism under these cases. This may result from altered pressure-flow characteristics caused by headward fluid shift. It will be of great interest to compare the hemodynamic changes during this flight with the findings documented by the neurophysiology studies. Altered nervous system activity corresponding to hemodynamic changes would support a hypothesis that changes may be induced by altered blood flow under these circumstances.

The question of parasympathetic versus sympathetic influences can be answered during subsequent flights by injecting appropriate blocking agents during flight, or by testing of the animals in the immediate postflight period (reaction compared to preflight response).

### 3. Ground Based Synchronous Experiment with Samurai and Kvak

SGBEs were conducted with the reserve flight animals Samurai and Kvak. These animals were instrumented in an identical manner to the flight animal and treated in an identical fashion in all respects except exposure to weightlessness. The 6 day SGBEs with these two animals were conducted at the Institute of Biomedical Problems, Moscow, USSR on 15 August to 22 August, 1985.

#### a. Findings for Samurai

Results over the course of the study for Samurai are shown for heart rate, carotid pressure and carotid flow in Figures IV-A through IV-H and compared to data collected in Gordyy during the synchronous ground based experiment conducted 20 August 1985. Mean day/night changes are shown in Figures IV-I through IV-P.

##### • Heart Rate

Heart rate showed the expected daily variation (Figure IV-A), ranging from about 96 to 142 bpm. Low values were regularly seen during the lights off period and peak values occurring between 1800 and 2400 hours. Daily mean values showed little change over the 6 days until Day 5 when mean values fell to 102 bpm from initial values of 112 bpm ( $p < 0.05$ ). Heart rate levels for Samurai were always significantly lower than Gordyy (Figures IV-A and IV-I). Day/night comparisons showed heart rate levels to be lower at night which became significant on Days 3, 4 and 6 in Samurai and Days 3 and 4 in Gordyy.

- Blood Pressure

Carotid pressure (Figures IV-B through IV-D, and IV-J through IV-L) also showed prominent and well expressed daily rhythms over the experiment (Figure IV-D). The values tended to be lowest at night. Daily mean values (Figures IV-D and IV-L) showed a tendency to decrease over the course of the study, becoming significant ( $p < 0.01$ ) by Day 5. Such changes did not occur for Gordyy. Mean day/night variations in blood pressure showed lower night mean pressures throughout for Samurai which were due to lower systolic as well as diastolic levels (IV-J and IV-K)). Values were significantly lower than for Gordyy throughout.

- Blood Flow Velocity

Blood flow velocity (Figures IV-E through IV-G, IV-M through IV-O) also showed a tendency for daily variations with values higher at night. Mean daily values showed a tendency to decrease on Days 3 and 6 and were highest on Days 1 and 4. Values on Day 6 were significantly lower than on Days 1 and 2. In general absolute levels were lower ( $p < 0.011$ ) in Samurai than those measured in Gordyy (35 vs 44 cm/sec) but closer than the still lower ( $p < 0.01$ ) values in Kvak (22 cm/sec, see below).

- Peripheral Vascular Resistance

Calculated values showed expected daily variations (Figures IV-H and IV-P). Mean values in Samurai tended to be lower than in Gordyy and became significantly so on Days 1, 2 and 5. Night time levels were regularly lower in Samurai and became markedly so starting on Day 3 of the study.

b. Findings for Kvak

Findings from Kvak for daily changes in heart rate, carotid pressure and carotid flow velocity, are shown in Figures IV-Q through IV-X. Means for each day of study, including day/night changes for respective parameters are given in IV-Y through IV-AF. Day 1 values were incomplete; mean values are not shown for Day 1 except for heart rate.

- Heart Rate

Mean heart rate (Figure IV-Q) showed daily variations ranging from 10 to 38 bpm over the course of the study. However, each daily 24-hour mean heart rate did not vary significantly over the 6-day period as shown in Figure IV-Y. Day 4 results showed large 24-hour variations. Changes in general were close to those recorded in Gordyy, particularly by the end of the study.



- Blood Pressure

Daily blood pressure changes are shown in Figures IV-R through T, with respective mean values plotted in Figures IV-Z, IV-AA, and IV-AB. Values showed 24-hour variations (Figure IV-T), and variable responses, with smaller changes on Days 2 and 4. Comparison of daily changes in pressure showed significant ( $p < 0.01$ ) decrease. The minimal changes on Days 2 and 4 could represent incomplete adaptation of the animal to the condition of the study. Similar changes occurred for Samurai.

- Blood Flow Velocity

Changes over the course of the study are shown in Figures IV-U through W, with mean values shown in IV-AC through AE. Accurate readings (20 beat segments) could not be obtained at all of the timed intervals due to artifacts in the obtained tracings due to possible head positional changes, or poor operation of the transducer. The missing areas will require re-editing of the data by hand which was not possible to complete for this report. The minimal available data, as shown, demonstrates some daily variation over the course of the study and fluctuations of 8-10 cm/sec. Mean flow did not change over the course of the study. In contrast to mean blood pressure (Figure IV-AB) which showed a tendency to fall over the course of the study, mean flow tended to increase (Figure IV-AE). Absolute levels for flow velocity were one-half that observed in Gordyy during similar conditions (Figure IV-W).

- Peripheral Vascular Resistance

Due to the incomplete data set for carotid flow velocity, these calculations must be considered qualitative at best (Figure IV-X and IV-AF). Accurate values will need to be reported at a future time. Vascular resistance proved to be higher throughout in Kvak compared to Gordyy (Figure IV-X) and tended to decrease over the course of the study, almost equalling values in Gordyy by Day 6 of the study.

In summary, the comparisons of the three animals indicate:

- Heart rates remained stable (did not decrease) over the period of the study, as occurred during flight. Absolute values for heart rate during flight were lower.
- Blood pressure (particularly systolic and mean values) did not increase over the period of the study in any animals, as it did during flight.
- A marked elevation of peripheral vascular resistance (of a magnitude seen with flight) did not occur, nor were significant (wide) daily variations seen.
- Day/night variations for the above data were present, but not of the magnitude seen with the flight animal during exposure to weightlessness.
- Results for both flight candidate animals, with regard to change from baseline, agreed well with those obtained for the flight animal (Gordyy), when tested on the ground. All three animals were tested under identical conditions, the flight animal being evaluated one month following spaceflight.

#### 4. Tilt Test Results

Tilt tests were conducted in the flight and ground-based support animals in order to better understand the magnitude and nature of cardiovascular change occurring with weightlessness, or after 6-day immobilization procedures (chair restraint) as occurred in the SGBE. The testing protocol, was that previously described (see Methods section) and jointly determined with Soviet co-investigators.

Results of two tilt tests conducted on Kvak (24 June and 23 August) are shown in Figures V-A and V-B with results of analysis for comparative heart rate, blood pressure and flow changes shown in figures V-C through E, respectively. Tabular values representing one minute values for heart rate, mean blood pressure, pulse pressure, and mean carotid blood flow velocity are included in Table V-1.

Results of the three tilt tests conducted on Samurai (28 June, 12 August and 23 August) are shown in Figures V-F through H, with results for comparative heart rate, blood pressure and flow given in figures V-I through K. Tabular values representing one minute values for heart rate, mean blood pressure, pulse pressure, and mean carotid blood flow velocity are included in Table V-1.

Results of the three tilt tests conducted in the flight animal Gordyy are shown in Figures V-L through V-N with comparative tilt results for heart rate, blood pressure and flow given in figures V-O through Q. Tabular values representing one minute values for heart rate, mean blood pressure, pulse pressure, and mean carotid blood flow velocity are included in Table V-1.

Comparison of tilt test results between the animals is given in Table V-1, which includes the mean data (calculated for each respective 5 or 6 minute test segment) for each period of the test procedure. Data on the immediate postflight test in Gordyy is not included in this analysis. Data in Table V-1 is grouped according to recorded parameters with heart rate (HR) first, followed by mean blood pressure (BP), then pulse pressure (PP) and finally mean blood flow (BF) velocity. Values are listed in the times sequence of the test starting with the 0° body position, then +70°, -70°, 0°, -70°, +70° and finally 0°. Values listed in the column to the far right represent the mean values +/- SE for all animals (recorded over the seven tests) at that particular phase of the test procedure for a selected respective hemodynamic parameter. A cursory analysis of the data reveals fairly wide variations of resting state (initial resting 0°) values) between animals and for a given parameter in the same animals on repeat testing. Yet, given these apparent differences, responses to each respective test followed a similar pattern in all animals; heart rate usually increasing with +70° tilt, and decreasing or returning toward normal, when at -70°. Blood pressure evidenced reciprocal changes to heart rate.

##### a. Heart Rates

Resting heart rate levels in Gordyy (220 and 236 bpm) were much higher than in the other animals and persisted over the duration of the tests. The elevated rates may in part be a reaction to the anesthetic agent (Valium). Mean heart rates for all animals in Table V-1, showed a slight elevation with +70°, slight decrease (non-significant) with -70°, return to baseline with 0°, a subsequent decrease with -70° and slightly depressed (relative to initial resting levels, but non-significant) on final return to 0° at the end of the study. Each animal

generally followed this pattern except Samurai who failed to show heart rate elevation with +70° tilt.

To better follow specific changes in a given parameter over the course of the tilt, data were plotted as changes from mean resting levels (determined from the three 0 periods) as shown in Figures V-C, V-I, and V-O. Heart rate changes for the two studies with Kvak (Figure V-C) showed that heart rate increased 20 bpm from baseline levels during the early phases of both +70° exposures, but fell back to baseline over the last two minutes of the preflight test. Values fell during the -70° phase, but reached baseline levels only in the post synchronous control test. Values returned to baseline levels by the last two minutes of the 0° period in both tests. After an initial heart rate elevation, both tests showed a decline at -70° and then a sharp increase on positioning at +70° which then fell gradually, staying 10 bpm above baseline in the first test and 10 bpm below baseline in the other.

Heart rate changes for the three studies in Samurai (Figure V-I) were similar to that in Kvak and differed only in a fall (instead of a rise) in heart rate immediately upon placement in the +70° position during the preflight tilt and a rise in heart rate (instead of fall) immediately upon placement in the last (second) +70° position during the 23 August (post synchronous control) study. Changes for the flight animal Gordyy are shown in Figure V-O and were similar to those for Kvak; a +70° tilt resulted in a 20 bpm increase in heart rate.

#### b. Blood Pressure

Mean blood pressure levels showed marked variation from animal to animal and from test to test in the same animal. Means for the entire study (see Table V-1) showed a marked drop ( $p < 0.01$ ) from 122 mmHg to 107 mmHg with +70° tilt, returning to baseline with a slight overshoot at -70°; falling again to 101 mmHg ( $p < 0.01$ ) with the last +70° tilt.

Analysis of blood pressure showed similar changes in all three animals. Changes for Kvak during these studies (Figure V-D) showed greater decrease during the preflight test than after the synchronous control experiment, particularly during the last +70° exposure. Similar changes occurred for Samurai (Figure V-J) with the greatest decrease during the post synchronous control exposure. Gordyy (Figure V-P) also showed larger decreases during the second +70° tilt, immediately post-flight.

#### c. Blood Flow Velocity

In general blood flow (Table V-1) showed only slight changes with the various tilt positions, decreasing slightly with +70°, remaining depressed at -70°, returning to baseline during the 0 period and decreasing again with +70° exposure.

Changes from baseline are shown for Kvak in Figure V-E. Analysis was complicated in this instance by absolute values during the post synchronous control experiment, which were 40-50% lower than during the preflight experiment. The reason remains unexplained. This may have been due to head position changes during the test period, or poor function of the transducer. Blood flow velocity, however showed expected changes during both studies. Blood flow velocity during the preflight test did not return to baseline levels after the first -70° procedure (0° period) until the last two minutes of monitoring, showed little change during the subsequent -70° tilt and then rapidly dropped during the ensuing +70°

tilt, gradually returning to baseline levels by the last several minutes of tilt. The largest and most persistent changes in flow during the second study occurred during the second +70° tilt exposure.

Changes for Samurai are shown in Figure V-K. Flow showed expected changes during each of the studies, falling with +70° tilt initially as much as 40-50 cm/sec with subsequent return toward baseline. The -70° tilt resulted in slight falls. The 0° position after the initial +70° tilt and -70° tilts resulted in higher flow values on the test conducted 12 August than in the other two studies.

Flow velocity changes for Gordyy are shown in Figure V-Q. Post-flight changes showed dramatic differences compared to the other two tests with consistently greater changes over the entire time course of the procedures. Flow velocity was depressed 30 cm/sec during the initial +70° tilt, failed to return to baseline during the -70° phase and reached baseline levels on return to 0° only during the last minute. The following -70° body position change again resulted in a 20 cm/sec decrease and 30 cm/sec loss occurred during +70°. In contrast, the animal reacted more rapidly and compensated for the body changes more adequately during the pre-flight and post-synchronous control experiments.

#### d. Pulse Pressure

Pulse pressures (PP) were calculated in Table V-1 as a means of determining whether significant change in cardiac output (stroke volume) occurred over the various phases of the tilt procedure. As shown, few significant changes occurred. Pulse pressure dropped 3-5 mmHg with +70° tilt and 5-6 mmHg with -70° tilt. These results support the conclusion that blood flow velocity changes did not occur during these ground based tests, in contrast to tests done after spaceflight.

#### e. Group Mean Changes

Figure V-R illustrates the changes in mean (group) values for heart rate, blood pressure and flow velocity taken from data for all seven tilt tests as listed in Table V-1. These curves then represent the average changes over the course of the protocol for all animals, obtained during ground experiments when not exposed to spaceflight. Figures V-S through V-U show the derived changes from baseline for each phase of the study respectively for heart rate, mean blood pressure and mean blood flow and can be compared with findings during the immediate postflight tilt for Gordyy, in Figure V-M. Heart rate changes (Figure V-S) in the postflight tilt test for Gordyy were much less during each of the -70° tilts. Heart rate increased 5-6 bpm, instead of falling 10 bpm, and heart rate increase was far greater during the last +70° change (20 bpm vs 5 bpm). Blood pressure (Figure V-T) showed similar, almost identical +70° tilt decreases and slight increase with -70°. The most striking was that pressure remained depressed (20 to 30 mmHg) during the mid test period of return to horizontal body position (0°). Blood flow velocity (Figure V-U), in Gordyy was dramatically different in comparison to the group mean results. The postflight tilt test was associated with dramatic decreases in levels during the +70° tilts and a slow return to baseline level during the midterm return of body position to 0°, whereas the grouped mean results showed small and insignificant changes in flow across the study.

In summary, the tilt test proved to be valuable for studying cardiovascular control in this primate model. The "average" response curve to the test could be developed by studying a

number of animals. This response could be compared with postflight responses to demonstrate that "cardiovascular deconditioning" was present in the flight animal. The deconditioned state in this animal model was best characterized by changes in blood flow to the head and moderate changes in blood pressure. The accuracy and predictability of changes cannot be determined in flight until additional studies are done in non-flight animals, and postflight tests in future flight subjects.

## E. DISCUSSION AND CONCLUSIONS

### 1. Cosmos 1667

Findings demonstrate that significant cardiovascular change occurred for the test monkey over the course of the 6-day flight. Heart rate and blood pressure showed overt evidence of change over the course of the flight and did not demonstrate evidence of stabilization by the time of flight termination. Blood flow to the head was maintained with little alteration in absolute level, but this was accomplished at the expense of a significant increase in peripheral vascular resistance. Dramatic increases in arterial pulse pressure, as compared to control state, were also documented over the course of the flight. This may indicate inflight hemodynamic adjustments to the headward fluid shifts that are known to occur with weightlessness. Comparison of flight findings with the synchronous control data showed that hemodynamic adaptation to a weightless state requires greater than 7 days in this non-human primate model. A significant increase in heart rate was observed on launch and insertion into orbit, without evidence of blood pressure or flow alterations. Presence of a persistently increased pulse pressure, compared to synchronous control, provides suggestive evidence for an elevated stroke volume over the course of the mission. If real, the increases in stroke volume would tend to compensate for the observed decreases in flight heart rate, thus maintaining cardiac output unchanged over the course of the mission. These findings need to be verified by comparison with rheoplethysmographic determinations of cardiac output obtained by other Soviet co-investigators.

The validity of spaceflight hemodynamic changes were supported by ground based experiments in two additional flight candidate animals. Ground based experiments were conducted under conditions identical to flight, except for exposure to weightlessness. Cardiovascular reactions in these animals did not differ markedly from those of the flight animal when tested on the ground one month after spaceflight. In general these studies conducted for 7-9 days periods failed to show significant changes in heart rate, blood pressure, or peripheral vascular resistance. In contrast, changes in these parameters were a salient feature of spaceflight.

Evidence of cardiovascular deconditioning was seen in tilt tests conducted 3 days after recovery of the spacecraft. Plasma volume changes were probably not a significant factor in contributing to cardiovascular responses at this time. Changes were manifested by altered magnitude and time course of response for a given hemodynamic parameter, either during the period of exposure to body position change, or during recovery. Blood flow velocity showed the most change, followed by pressure. Such findings tend to support a hypothesis that nervous system control changes play a greater role in postflight cardiovascular changes than previously suggested. The significance of the immediate postflight changes were strengthened by data collected in the two backup flight animals who were also exposed to repeated tilt studies over the course of the experiment. Data in these latter animals agreed in general with that obtained from the flight animal when tested prior to flight and one month

later. A comparison of the immediate postflight tilt results from Gordyy and the average value for tilt flight response as obtained from pooling 7 tests conducted in the three animals, two backups and flight animal, showed the greatest changes in blood flow velocity followed by in blood pressure.

These studies suggest the need for further flight investigations using this primate model. Central nervous system parameters recorded during a mission should be compared with the hemodynamic findings described here. Our results suggest that this may uncover factors involved in controlling the changes seen.

Time did not permit analysis of all available data from the flight. Some preflight tilt test results from several flight candidate animals have yet to be analyzed. Some data were obtained during the bioengineering tests where electrical noise interfered with signal quality. This data would require processing by hand, with subsequent data entry into the computer for analysis. Twenty beat segments were not available for data events in several instances and would also require hand calculation which could not be accomplished for this analysis. Also, some calibration data has yet to be located which would be required.

## 2. Comparison of Results of Cosmos 1514 and 1667

Statistical comparison of the data from the Cosmos 1514 Cardiovascular Experiment with those of Cosmos 1667 revealed the following key differences (4).

- Heart rate in the Cosmos 1514 flight monkey, Bion, was significantly lower than in Gordyy throughout the study. The two animals showed the same trends in heart rate changes during flight despite the absolute differences in heart rate levels. An immediate initial drop from launch levels was associated with the assumed headward shift in blood and body fluid volumes on insertion into orbit (Day 1). A decrease in heart rate over the duration of the mission was probably due to a hypo-metabolic state induced during weightlessness.
- Mean carotid blood pressure was significantly higher in Gordyy than in Bion, on the launch pad and throughout flight. The reason for these differences is unclear. They could be related to inherent physiological variability within the species.
- While on the launch pad, blood flow velocity to the head was also significantly elevated in Gordyy as compared to Bion. Absolute values were higher in Gordyy over the entire mission duration. If total flow were the same, flow velocity should have been higher in Bion because Bion's flow transducer had a smaller cross-sectional area. The higher flow velocity and cross sectional area in Gordyy indicates a higher blood flow. The difference may have been due to a physiological dissimilarity between the 2 animals. Flow response in microgravity differed slightly between the two animals with Bion exhibiting a larger decrease during the first few days of flight.
- Vascular resistance varied slightly on a daily basis between the two animals, but overall changes were not significantly different.

## F. RECOMMENDATIONS

The chronically instrumented rhesus monkey used for these experiments appears to be an adequate model for studying the physiological effects of weightlessness. Significant alterations in blood pressure and flow to the head were seen to occur. Comparison of carotid pressure-flow dynamics with overall cardiac output changes demonstrated that the system autoregulated flow to the head, and that Day 2 of flight appeared to be the most difficult one for adaptation. There is sound evidence of hemodynamic consequences associated with the weightlessness induced headward shift of blood and fluid, including standing waves and most likely a resetting of baroreceptor responses. Based on these findings it is recommended that:

- This animal model be flown again to increase the number of observations for statistical validity. Data is needed on at least four additional animals.
- Data obtained from hemodynamic studies be correlated with findings from other Cosmos investigations, particularly data on cardiac output and neurovestibular reactions. Data from cardiac output studies will be invaluable in gauging the ability of the circulatory bed in the head and neck to auto-regulate. The finding that standing waves occur in microgravity may be useful for studying the space motion sickness syndrome which is experienced regularly in spaceflight. Cosmos 1667 was the first time that hemodynamic and neurovestibular measurements were made in the same animal during space flight. A comparison of results would have important scientific value.
- The external carotid artery should be ligated in the next series of animals in order to provide data on cerebral blood flow and thus oxygen delivery capabilities during space flight. A pressure and/or flow probe might be placed on the terminal aorta or iliac artery to register flow and pressure in the lower half of the body, for comparison with hemodynamics in the upper half.
- Improvements need to be made in the present cross-calibration system used to monitor both pressure and flow. The Ailtech transducer should be replaced with a more reliable, stable system. A calibration procedure using the flight animal needs to be performed using both laboratory equipment and the flight CV signal processor. The system needs to be extended to allow measurement of at least two flows simultaneously in the same animal. Improved computer-based analyses techniques now available can be employed in the reduction of data obtained during future missions. On-site data collection and analyses will make immediate calibration and data verification possible. A detailed description of a Personal Computer-based Data Acquisition and Reduction System (PC-DARS) appropriate for this use is available.
- CV data would be more meaningful if compared with related results obtained by Soviet co-investigators. This includes data on blood volume changes, measurement of cardiac output and neurophysiologic findings.

## G. REFERENCES

1. Mains, R. C., E.W. Gomersall. Final Reports of U.S. Monkey and Rat Experiments Flown of the Soviet Satellite Cosmos 1514. NASA Technical Memorandum 88223, 1986.
2. Hanson, K. R. and H. Sandler. Final Report of Cosmos 1514 and 1667 Cardiovascular Results, VOL. I-IV, 1988. (Unpublished NASA report).
3. Cosmos 1985 Cross Calibration Procedure, Rev. 6. in: Hanson, K. R. and H. Sandler. Final Report of Cosmos 1514 and 1667 Cardiovascular Results, Vol. I, 1988.(Unpublished NASA report).
4. Sandler, H., R. Osaki, C. Hu. Cosmos 1514 and Cosmos 1667 Comparison Report of Primate Cardiovascular Experiment, 1986. (Unpublished NASA report).
5. Cosmos '85 Cardiovascular Measurements Experiment Specifications and Procedures Manual, 1985. (Unpublished NASA report).
6. Sandler, H. Cosmos 1667 Primate Cardiovascular Experiment, Final Science Report, June, 1986. (Unpublished NASA report).



## LIST OF FIGURES AND TABLES, SECTION II

### FIGURES

I-A	Master List of Instrumented Animals and Tests for Cosmos 1667 .....	47
II-A	Gordyy - Heart Rate (Flight vs. Ground Control).....	48
II-B	Gordyy - Systolic Carotid Pressure (Flight vs. Ground Control).....	49
II-C	Gordyy - Diastolic Carotid Pressure (Flight vs. Ground Control) .....	50
II-D	Gordyy - Mean Carotid Pressure (Flight vs. Ground Control).....	51
II-E	Gordyy - Max Carotid Flow (Flight vs. Ground Control).....	52
II-F	Gordyy - Min Carotid Flow (Flight vs. Ground Control).....	53
II-G	Gordyy - Mean Carotid Flow (Flight vs. Ground Control).....	54
II-H	Gordyy - Peripheral Resistance (Flight vs. Ground Control).....	55
II-I	Gordyy - Heart Rate (Flight vs. Ground Control, Daily Means) .....	56
II-J	Gordyy - Systolic Carotid Pressure (Flight vs. Ground Control, Daily Means).....	57
II-K	Gordyy - Diastolic Carotid Pressure (Flight vs. Ground Control, Daily Means).....	58
II-L	Gordyy - Mean Carotid Pressure (Flight vs. Ground Control, Daily Means).....	59
II-M	Gordyy - Max Carotid Flow (Flight vs. Ground Control, Daily Means) ....	60
II-N	Gordyy - Min Carotid Flow (Flight vs. Ground Control, Daily Means).....	61
II-O	Gordyy - Mean Carotid Flow (Flight vs. Ground Control, Daily Means) ..	62
II-P	Gordyy - Peripheral Resistance (Flight vs. Ground Control, Daily Means) .....	63
III-A	Gordyy - Heart Rate (Flight vs. Ground Control, Day vs.Night).....	64
III-B	Gordyy - Systolic Carotid Pressure (Flight vs. Ground Control, Day vs. Night).....	65

III-C	Gordyy - Diastolic Carotid Pressure (Flight vs. Ground Control, Day vs. Night) .....	66
III-D	Gordyy - Mean Carotid Pressure (Flight vs. Ground Control, Day vs. Night) .....	67
III-E	Gordyy - Max Carotid Flow (Flight vs. Ground Control, Day vs. Night)...	68
III-F	Gordyy - Min Carotid Flow (Flight vs. Ground Control, Day vs. Night)....	69
III-G	Gordyy - Mean Carotid Flow (Flight vs. Ground Control, Day vs. Night) .....	70
III-H	Gordyy - Peripheral Resistance (Flight vs. Ground Control, Day vs. Night) .....	71
IV-A	Gordyy, Samurai - Postflight Controls - Heart Rate.....	72
IV-B	Gordyy, Samurai - Postflight Controls - Systolic Carotid Pressure.....	73
IV-C	Gordyy, Samurai - Postflight Controls - Diastolic Carotid Pressure.....	74
IV-D	Gordyy, Samurai - Postflight Controls - Mean Carotid Pressure .....	75
IV-E	Gordyy, Samurai - Postflight Controls - Max Carotid Pressure .....	76
IV-F	Gordyy, Samurai - Postflight Controls - Min Carotid Pressure .....	77
IV-G	Gordyy, Samurai - Postflight Controls - Mean Carotid Flow.....	78
IV-H	Gordyy, Samurai - Postflight Controls - Peripheral Resistance.....	79
IV-I	Gordyy, Samurai - Postflight Controls - Heart Rate.....	80
IV-J	Gordyy, Samurai - Postflight Controls - Systolic Carotid Pressure.....	81
IV-K	Gordyy, Samurai - Postflight Controls - Diastolic Carotid Pressure.....	82
IV-L	Gordyy, Samurai - Postflight Controls - Mean Carotid Pressure .....	83
IV-M	Gordyy, Samurai - Postflight Controls - Max Carotid Flow.....	84
IV-N	Gordyy, Samurai - Postflight Controls- Min Carotid Flow.....	85
IV-O	Gordyy, Samurai - Postflight Controls - Mean Carotid Flow.....	86
IV-P	Gordyy, Samurai - Postflight Controls - Peripheral Resistance.....	87

IV-Q	Gordyy, Kvak - Postflight Controls - Heart Rate.....	88
IV-R	Gordyy, Kvak- Postflight Controls - Systolic Carotid Pressure.....	89
IV-S	Gordyy, Kvak- Postflight Controls - Diastolic Carotid Pressure.....	90
IV-T	Gordyy, Kvak- Postflight Controls - Mean Carotid Pressure .....	91
IV-U	Gordyy, Kvak- Postflight Controls - Max Carotid Flow.....	92
IV-V	Gordyy, Kvak- Postflight Controls - Min Carotid Flow.....	93
IV-W	Gordyy, Kvak- Postflight Controls - Mean Carotid Flow.....	94
IV-X	Gordyy, Kvak- Postflight Controls - Peripheral Resistance.....	95
IV-Y	Gordyy, Kvak - Postflight Controls - Heart Rate.....	96
IV-Z	Gordyy, Kvak- Postflight Controls - Systolic Carotid Pressure.....	97
IV-AA	Gordyy, Kvak- Postflight Controls - Diastolic Carotid Pressure.....	98
IV-AB	Gordyy, Kvak- Postflight Controls - Mean Carotid Pressure .....	99
IV-AC	Gordyy, Kvak- Postflight Controls - Max Carotid Flow.....	100
IV-AD	Gordyy, Kvak- Postflight Controls - Min Carotid Flow.....	101
IV-AE	Gordyy, Kvak- Postflight Controls - Mean Carotid Flow.....	102
IV-AF	Gordyy, Kvak- Postflight Controls - Peripheral Resistance.....	103
V-A	Kvak Tilt Data - Pre-Flight - June 24 1985.....	104
V-B	Kvak Tilt Data - Synchronous Control - August 23, 1985.....	105
V-C	Kvak Tilt Data - Comparison of Delta HR from Control.....	106
V-D	Kvak Tilt Data - Comparison of Delta CAP from Control .....	107
V-E	Kvak Tilt Data - Comparison of Delta CAF from Control.....	108
V-F	Samurai Tilt Data - Pre-Flight - June 27 1985.....	109
V-G	Samurai Tilt Data - Post-Flight - August 12, 1985.....	110

V-H	Samurai Tilt Data - Synchronous Control - August 23, 1985.....	111
V-I	Samurai Tilt Data - Comparison of Delta HR from Control.....	112
V-J	Gordyy Tilt Data - Comparison of Delta CAP from Control.....	113
V-K	Gordyy Tilt Data - Comparison of Delta CAF from Control.....	114
V-L	Gordyy Tilt Data - Pre-Flight Tilt.....	115
V-M	Gordyy Tilt Data - Post-Flight Tilt.....	116
V-N	Gordyy Tilt Data - Synchronous Control Tilt.....	117
V-O	Gordyy Tilt Data - Comparison of Delta HR from Control.....	118
V-P	Gordyy Tilt Data - Comparison of Delta CAP from Control.....	119
V-Q	Gordyy Tilt Data - Comparison of Delta CAF from Control.....	120
V-R	Mean of All Tilts, Excluding Gordyy Post-Flight.....	121
V-S	Gordyy Post-Flight vs. Other Tilts - Delta Heart Rate from Control.....	122
V-T	Gordyy Post-Flight vs. Other Tilts - Delta Mean CAP from Control.....	123
V-U	Gordyy Post-Flight vs. Other Tilts - Delta Mean CAF from Control.....	124

## TABLES

1.	Calibrations for systolic and diastolic CAP taken at mid-night on first and third day of testing over three experiment phases.....	125
V-1	Comparison of Kvak, Samurai and Gordyy plus Overall Tilt Test Results.....	126

COSMOS 1667 FLOW DIAGRAM FOR ALL INSTRUMENTED ANIMALS

SUBJECT	IMPLANT DATE	P-CELL NUMBER	EXT LEADS	X-CAL 1 TEST	BIO-ENG TEST	TILT X-CAL 2	FLIGHT	CONTROL 7 DAYS	TILT X-CAL
ANGEL	5/6/85	370	5/31	6/5	6/15	6/22	*7/6		
FRONYA	5/7/85	367	5/25			6/25			
KVAK	5/7/85	378	5/30			6/24		8/15	8/23
GORDYY	5/8/85	371	5/30	6/19		6/26	7/10	8/9	8/20
TROLL	5/28/85	365	6/10	6/17		6/27		**8/10	
SAMURAI	5/28/85	368	6/11	6/17		6/28		8/12	8/23

LEGEND:

\* INSTRUMENTATION NOT FUNCTIONING

\*\* HEMORRHAGE

FLIGHT  
GROUND  
LIGHT OFF

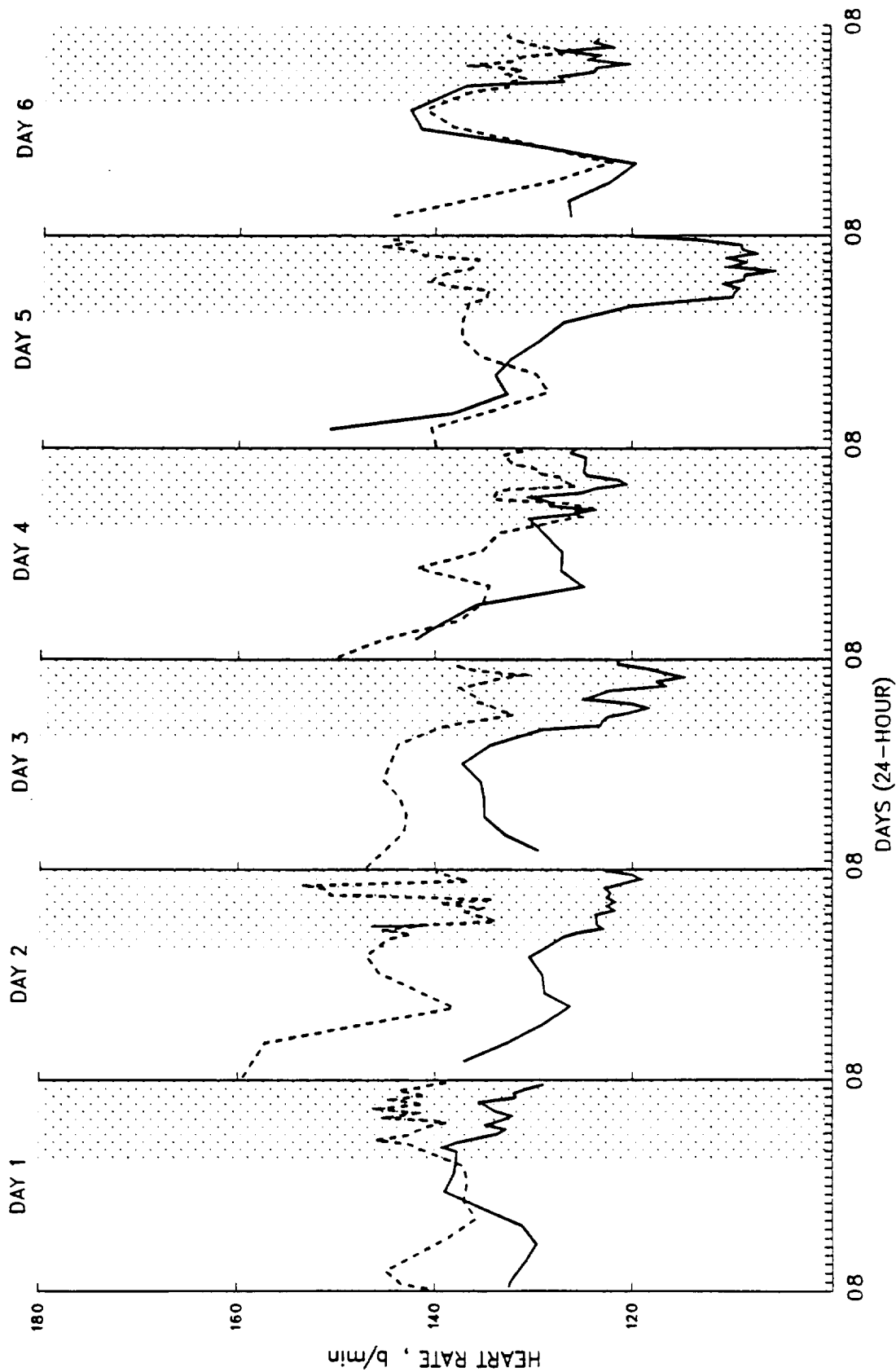

FIGURE II-A. COSMOS 1667 CARDIOVASCULAR EXPERIMENT

GORDYY  
HEART RATE

FLIGHT  
GROUND  
LIGHT OFF

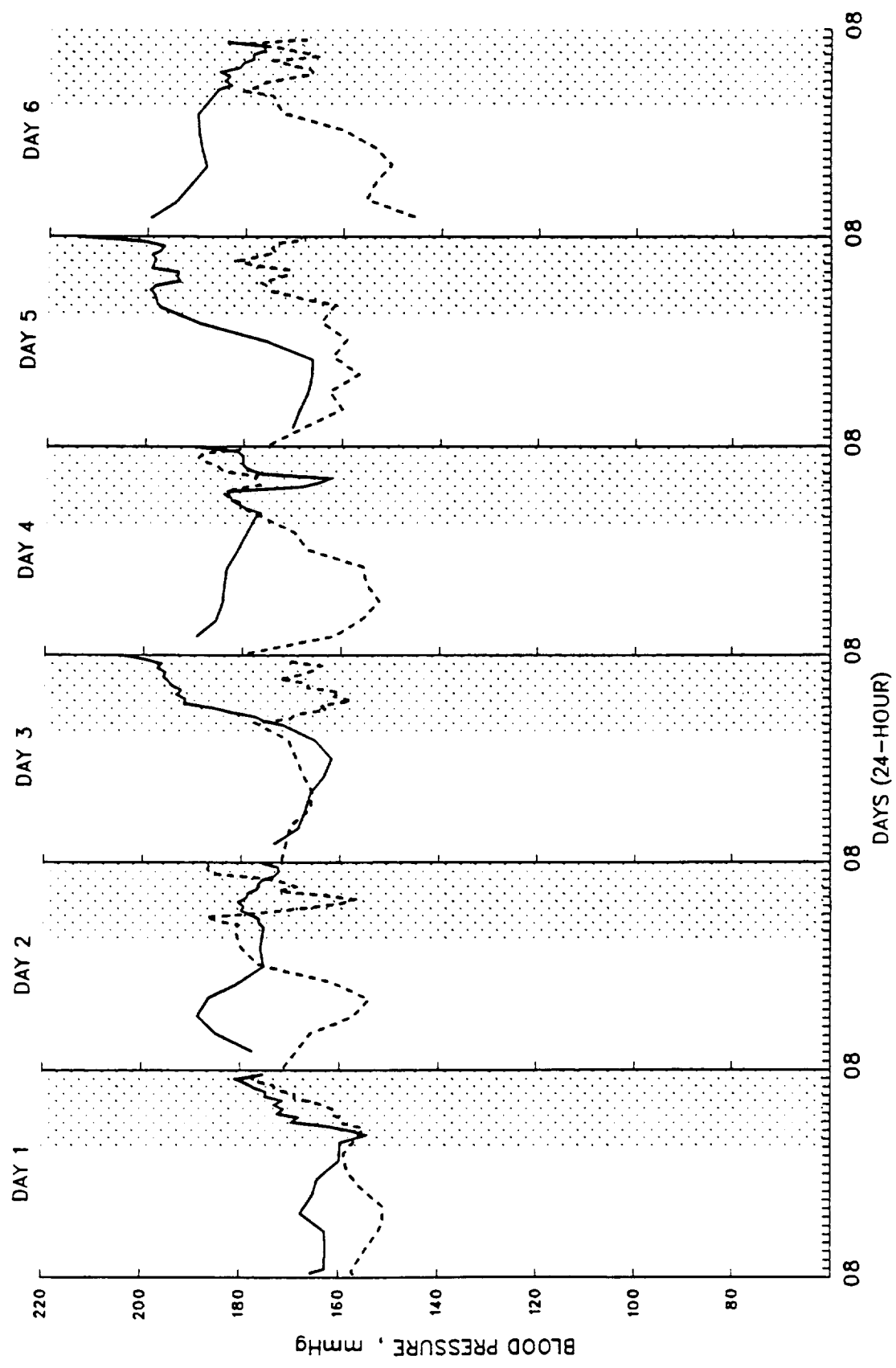

FIGURE II-B. COSMOS 1667 CARDIOVASCULAR EXPERIMENT  
GORDY  
SYSTOLIC CAROTID PRESSURE

FLIGHT  
GROUND  
LIGHT OFF

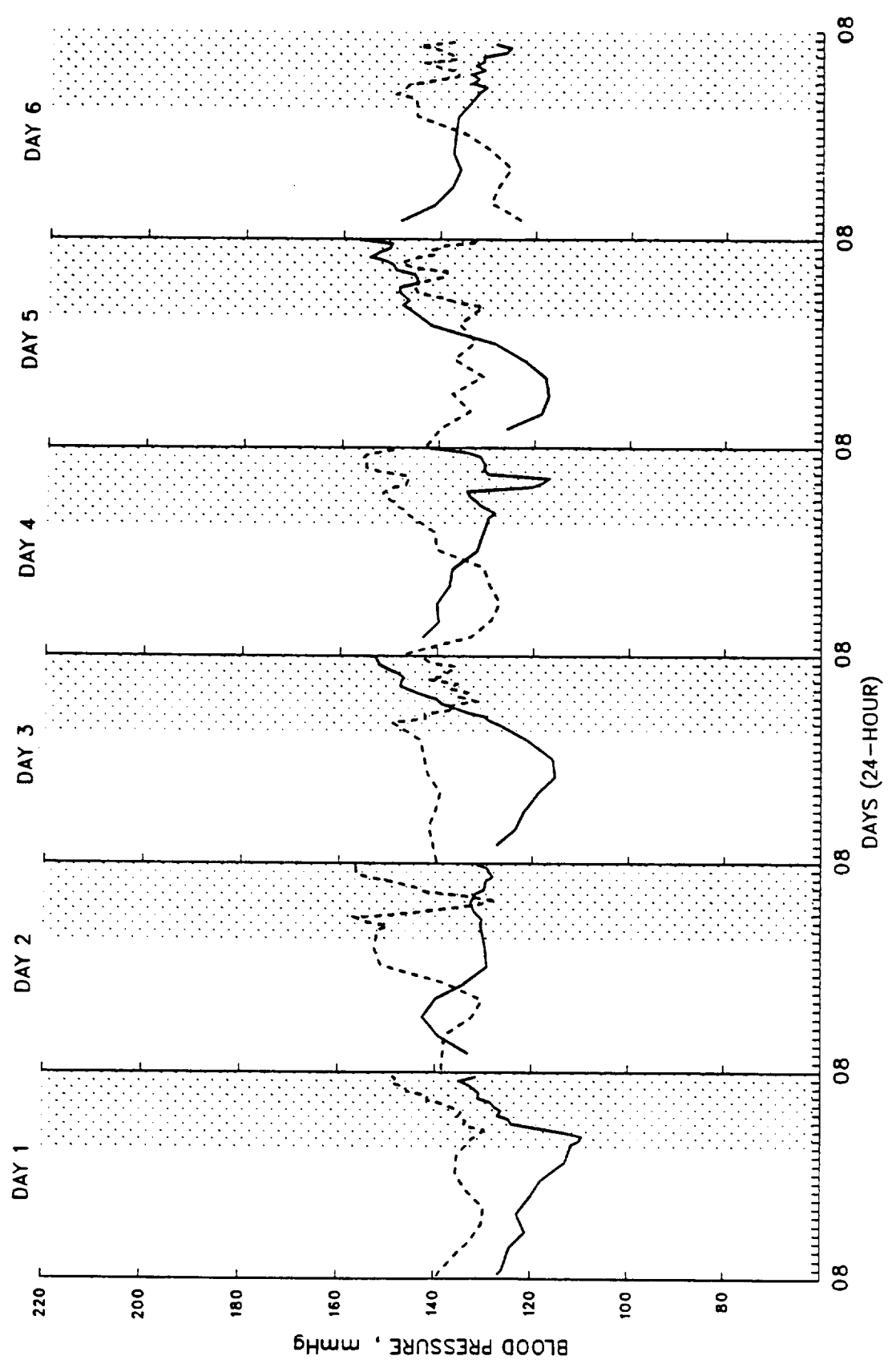

FIGURE II-C. COSMOS 1667 CARDIOVASCULAR EXPERIMENT  
GORDY  
DIASTOLIC CAROTID PRESSURE



FLIGHT  
GROUND  
LIGHT OFF

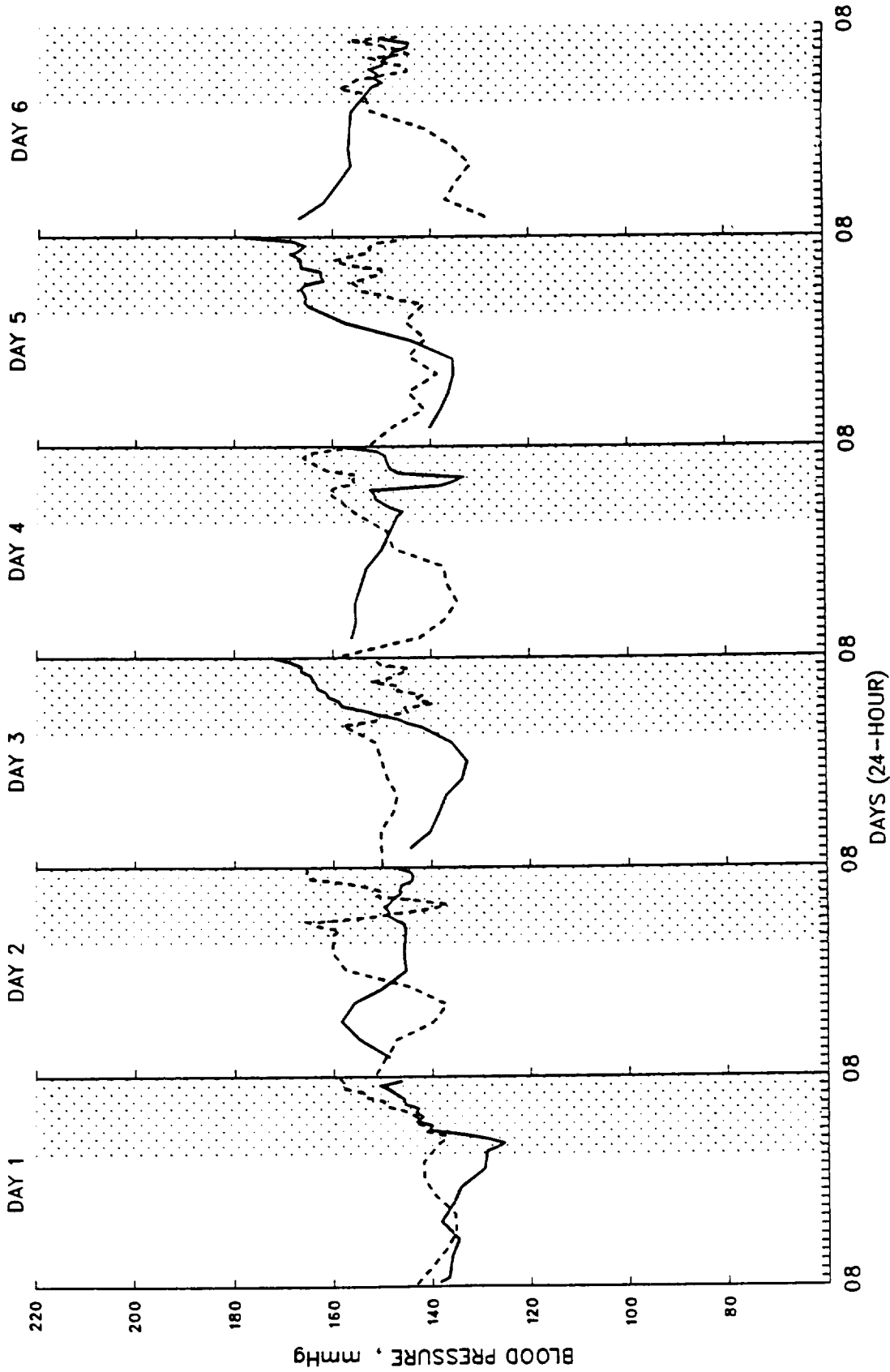

FIGURE II-D. COSMOS 1667 CARDIOVASCULAR EXPERIMENT

GORDYY

MEAN CAROTID PRESSURE

FLIGHT  
GROUND  
LIGHT OFF

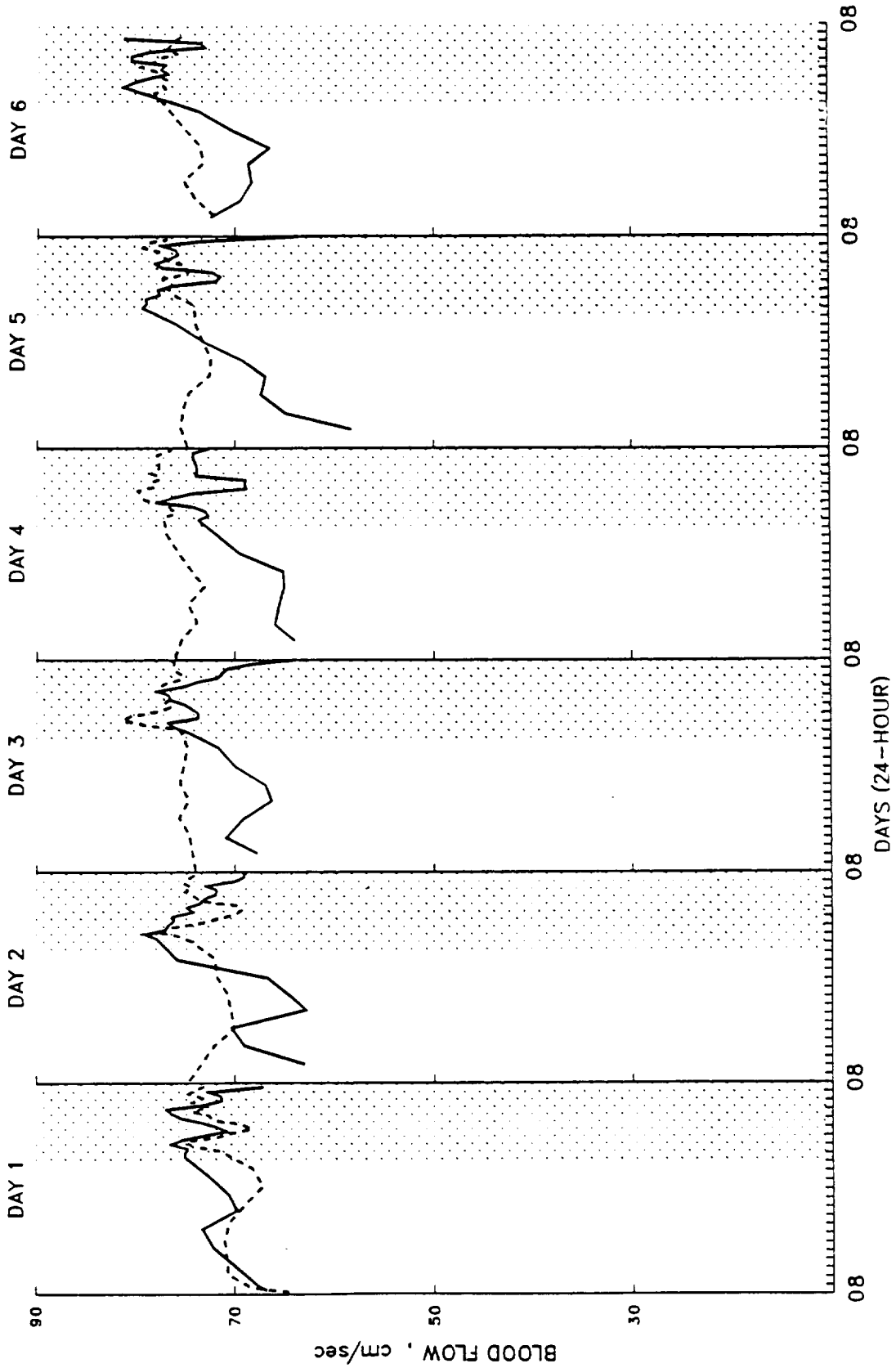

FIGURE II-E. COSMOS 1667 CARDIOVASCULAR EXPERIMENT

GORDYY  
MAX CAROTID FLOW

FLIGHT  
GROUND  
LIGHT OFF

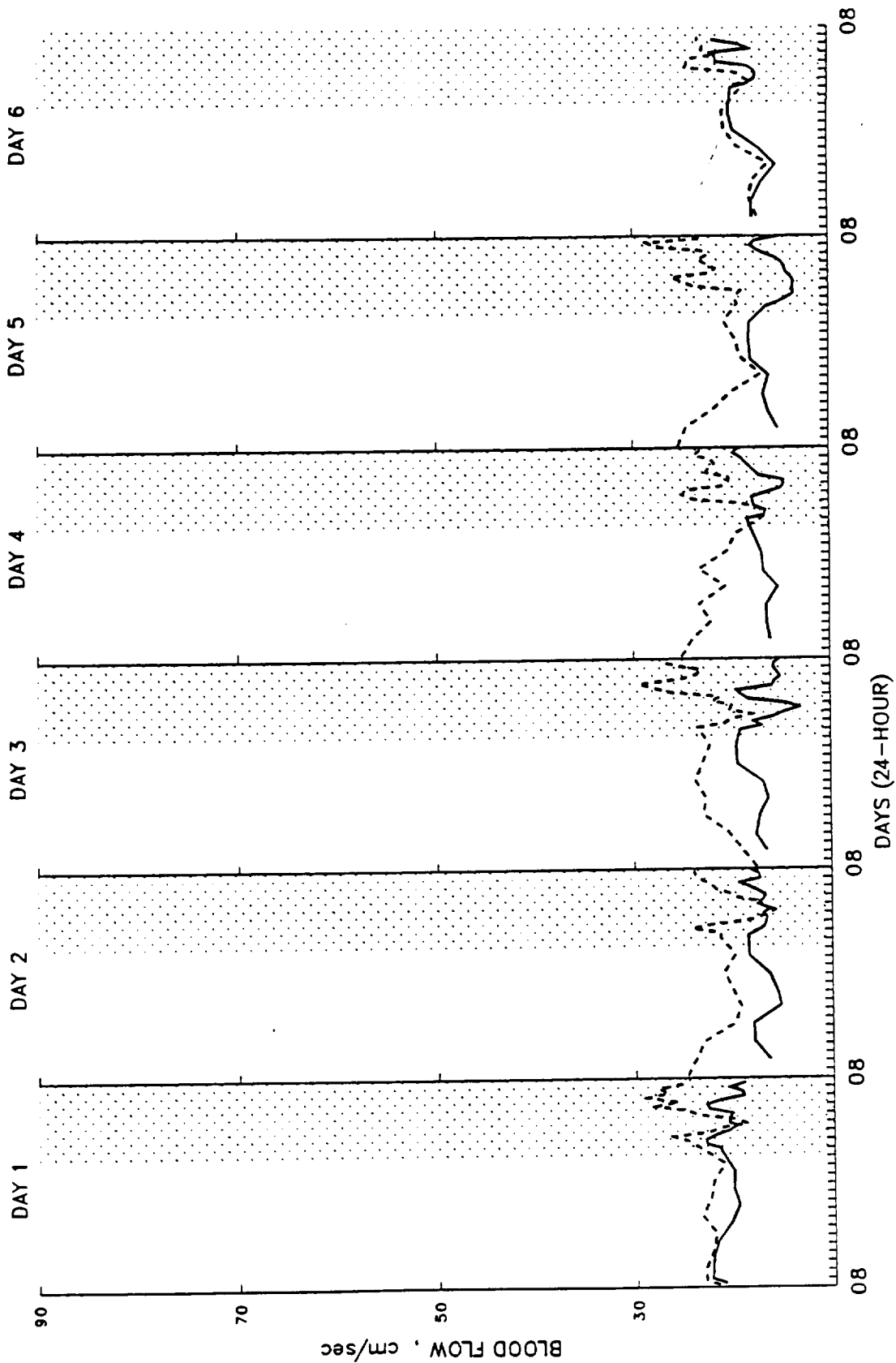

FIGURE II-F. COSMOS 1667 CARDIOVASCULAR EXPERIMENT

GORDY

MIN CAROTID FLOW

FLIGHT  
GROUND  
LIGHT OFF

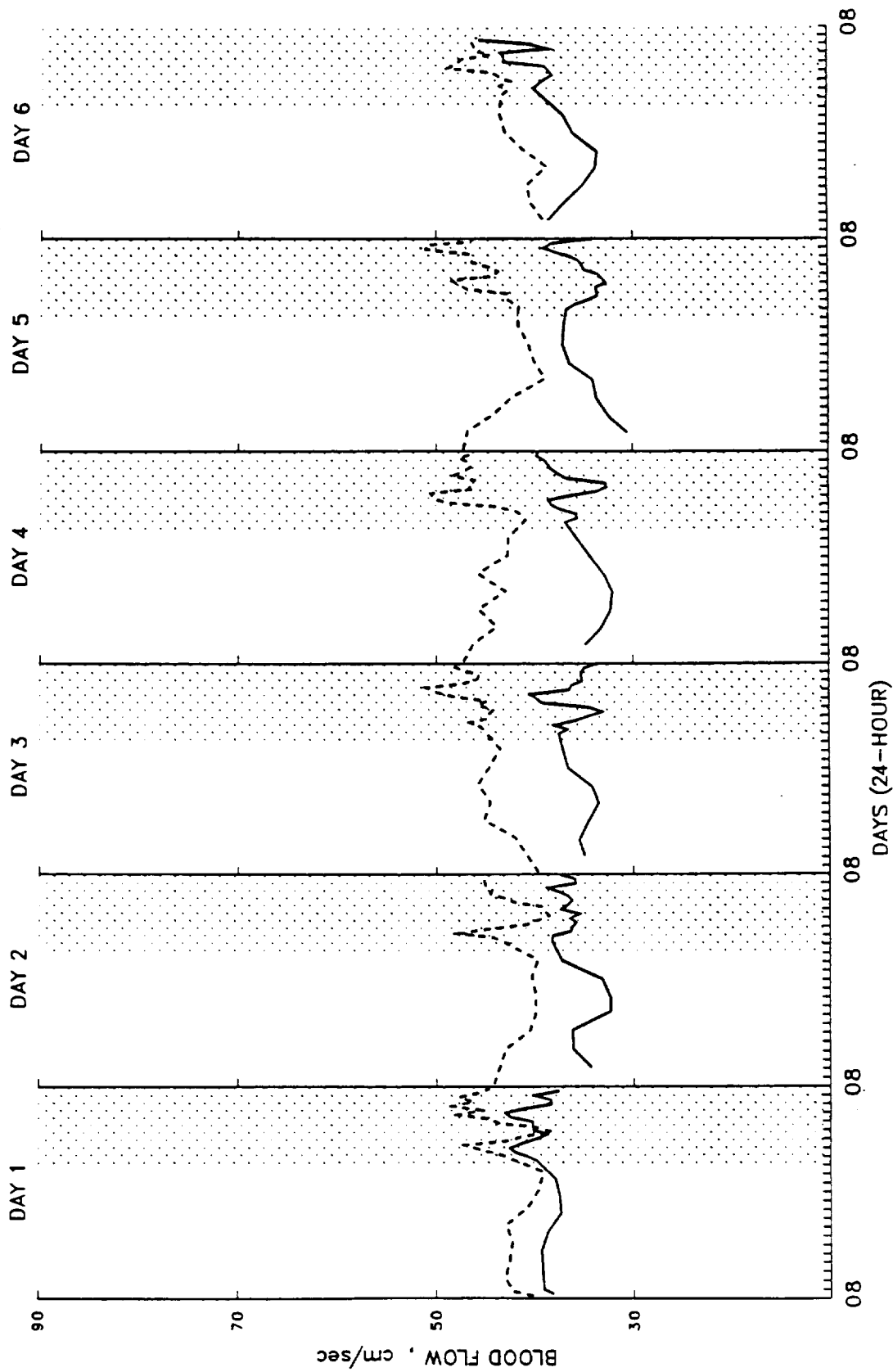

FIGURE II-G. COSMOS 1667 CARDIOVASCULAR EXPERIMENT

GORDYY

MEAN CAROTID FLOW

FLIGHT  
GROUND  
LIGHT OFF

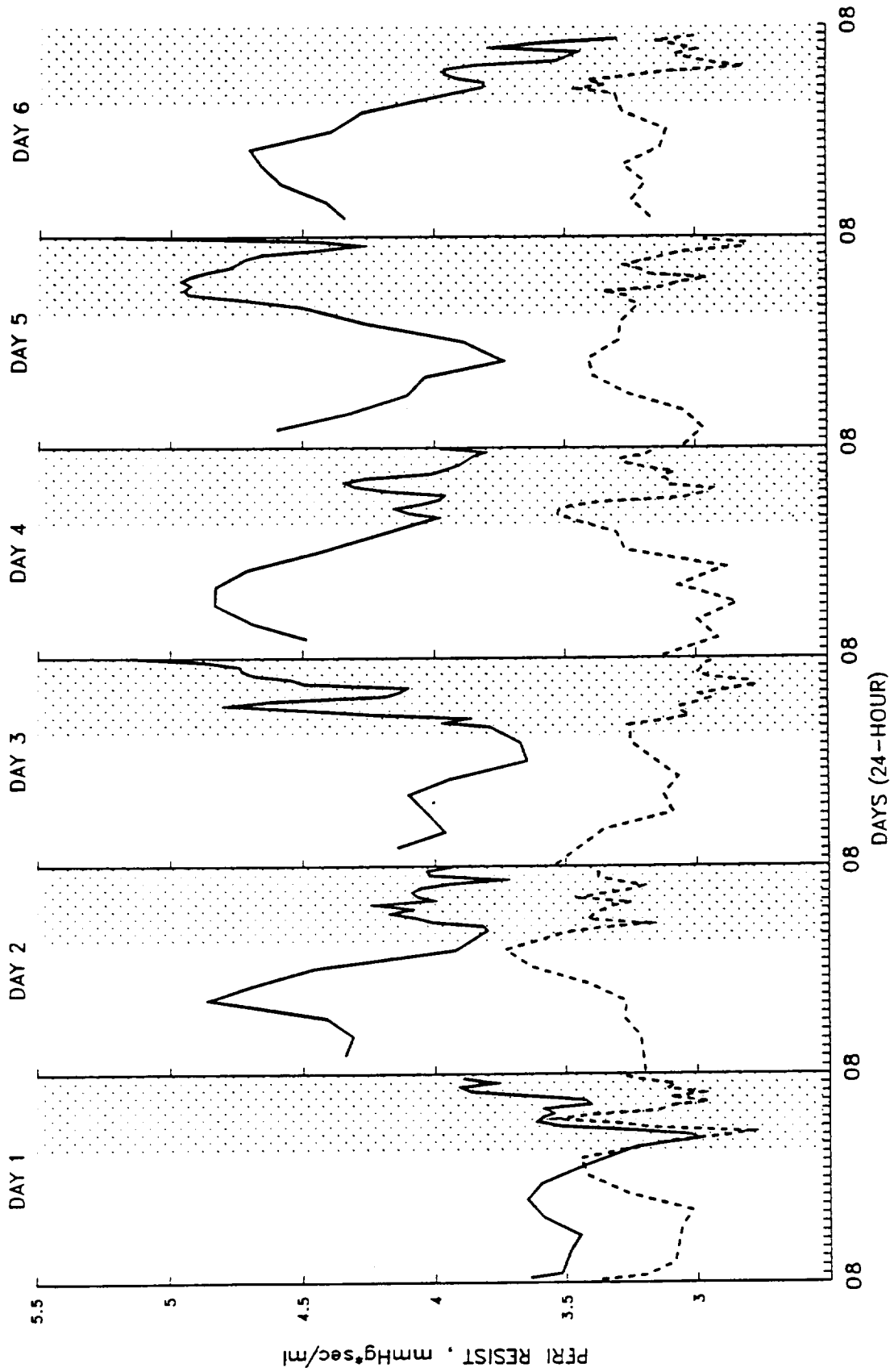

FIGURE II-H. COSMOS 1667 CARDIOVASCULAR EXPERIMENT  
GORDY  
PERIPHERAL RESISTANCE

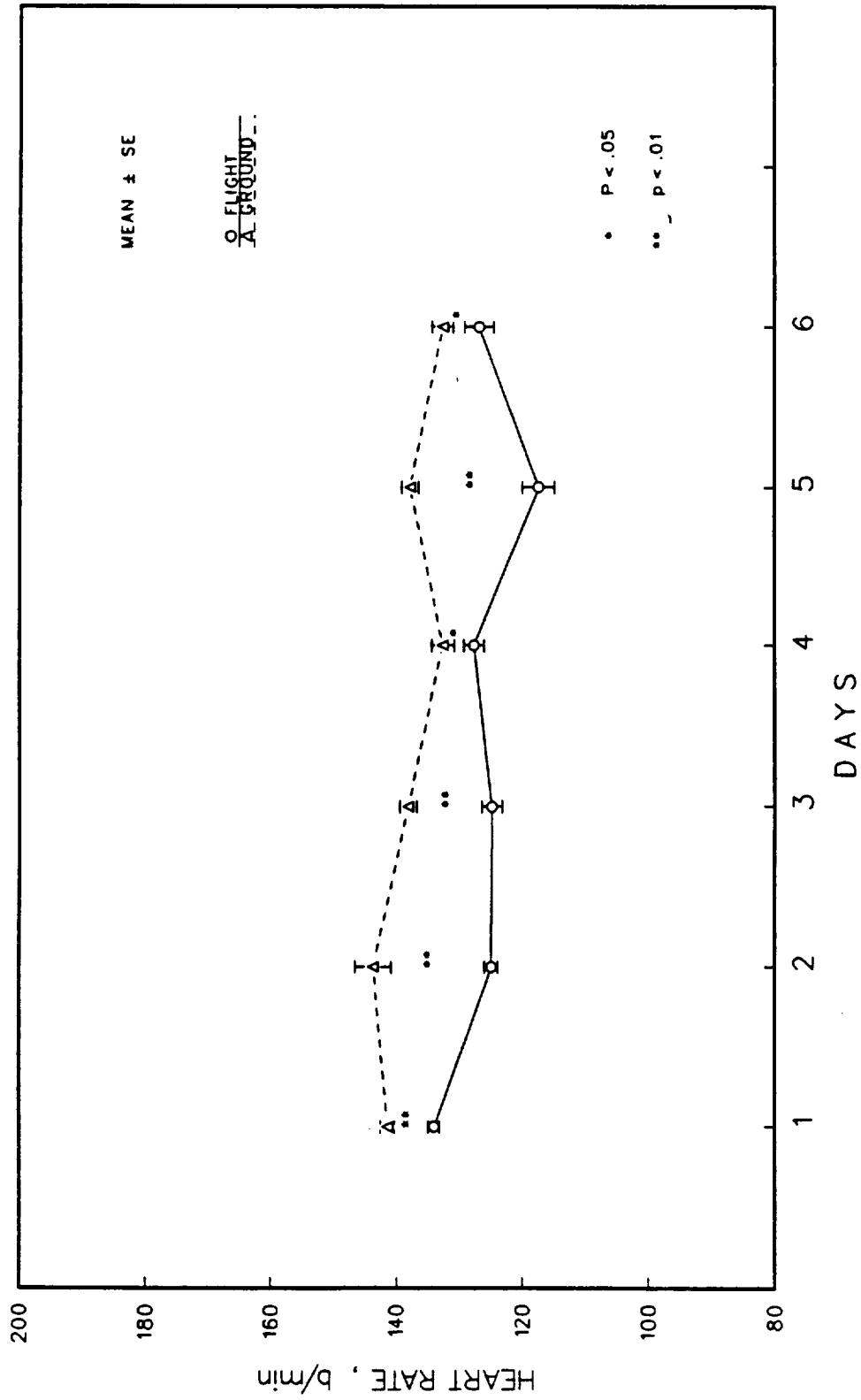

FIGURE II-I. COSMOS 1667 CARDIOVASCULAR EXPERIMENT  
GORDY  
HEART RATE

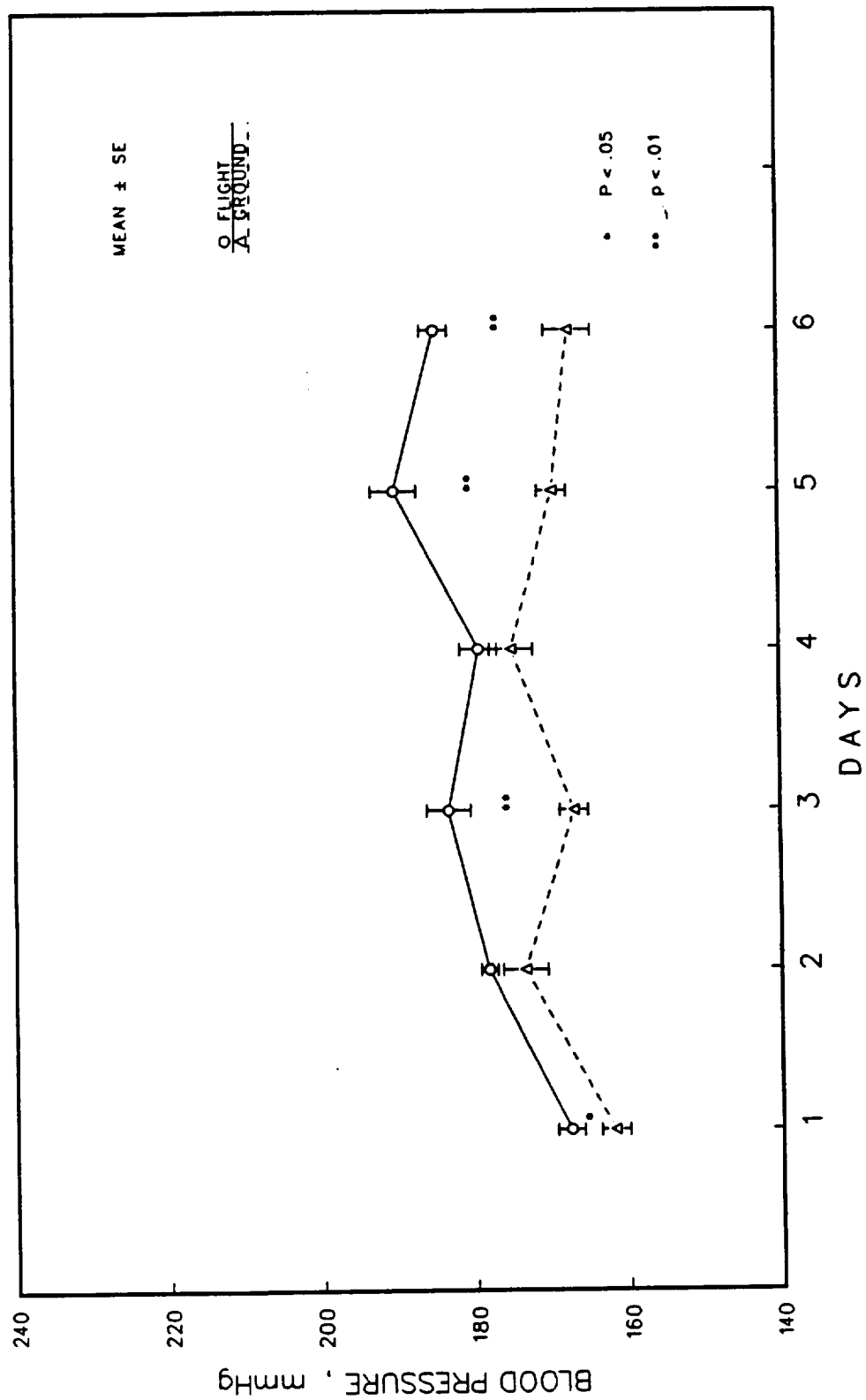

FIGURE II-J. COSMOS 1667 CARDIOVASCULAR EXPERIMENT  
GORDY  
SYSTOLIC CAROTID PRESSURE

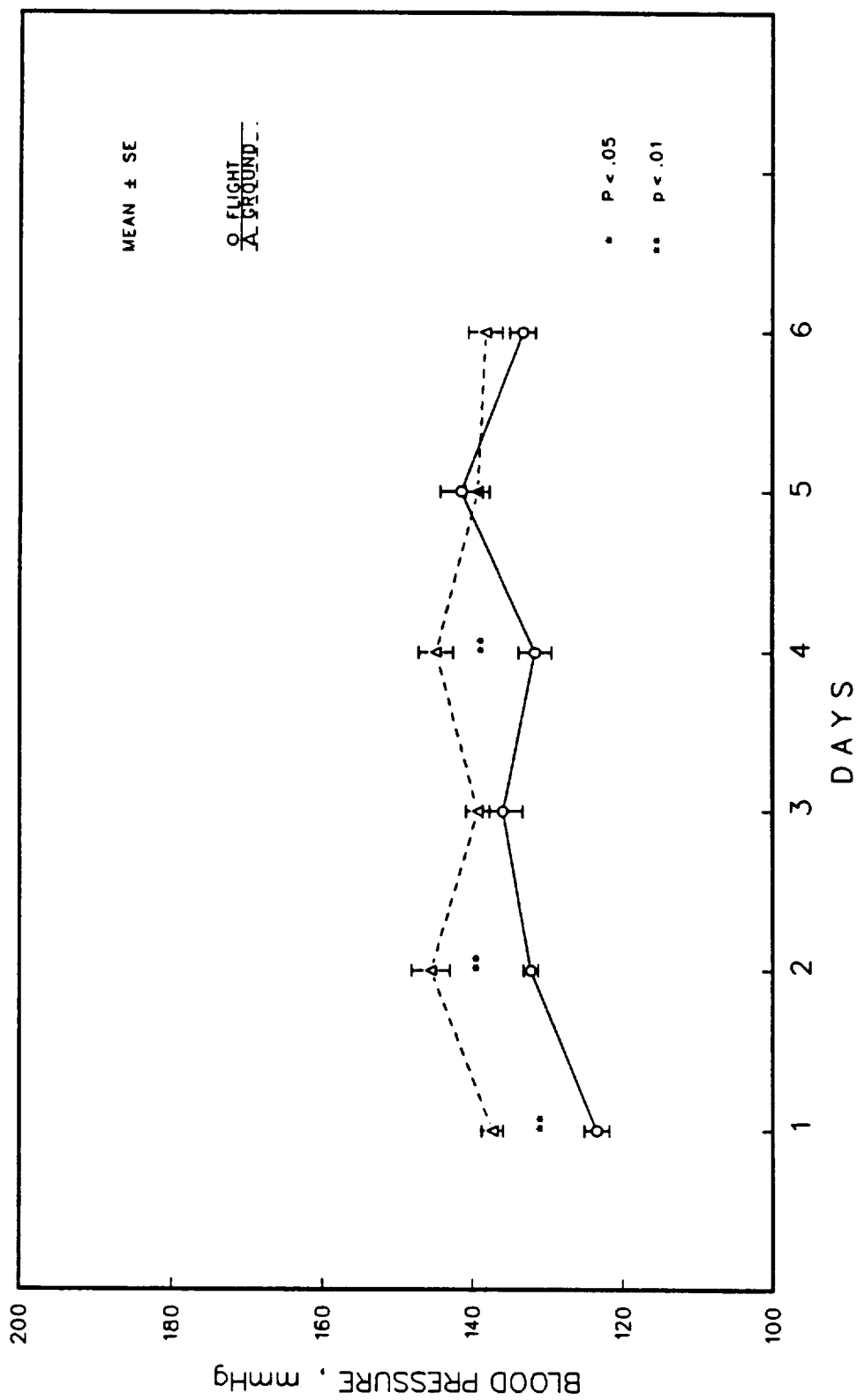

FIGURE II-K. COSMOS 1667 CARDIOVASCULAR EXPERIMENT  
GORDYY  
DIASTOLIC CAROTID PRESSURE



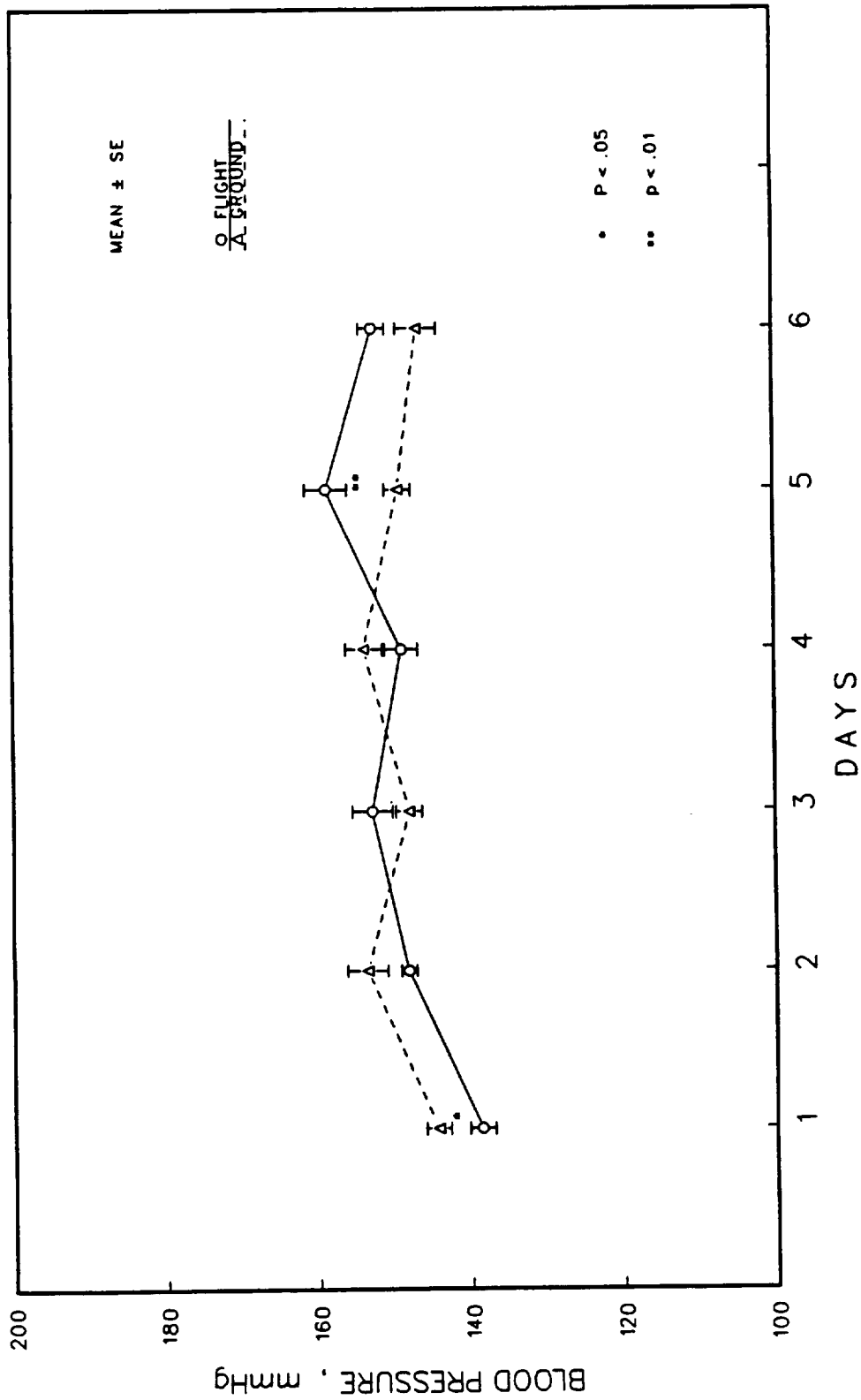

FIGURE II-L. COSMOS 1667 CARDIOVASCULAR EXPERIMENT  
GORDYY  
MEAN CAROTID PRESSURE

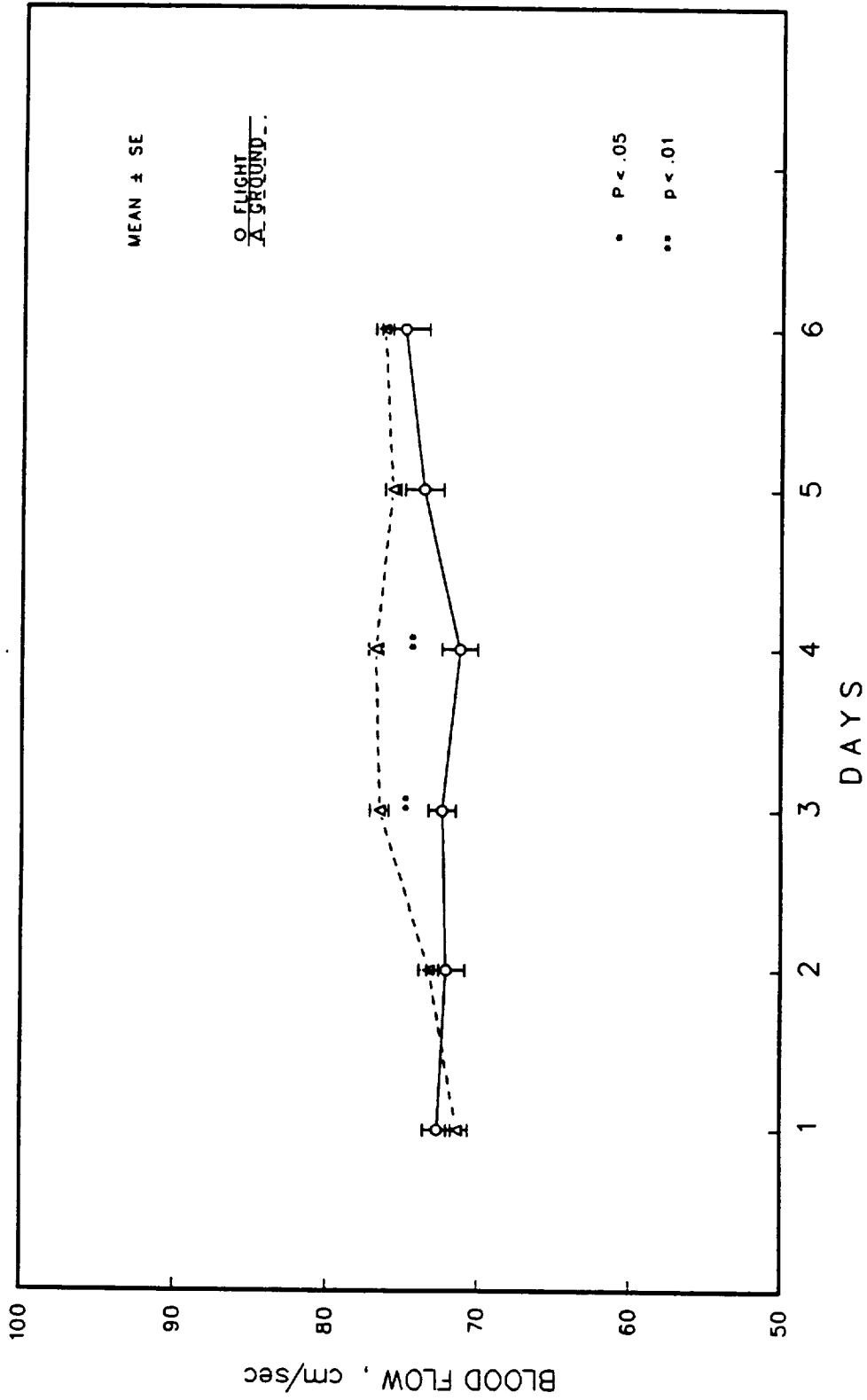

FIGURE II-M. COSMOS 1667 CARDIOVASCULAR EXPERIMENT  
GORDYY  
MAX CAROTID FLOW

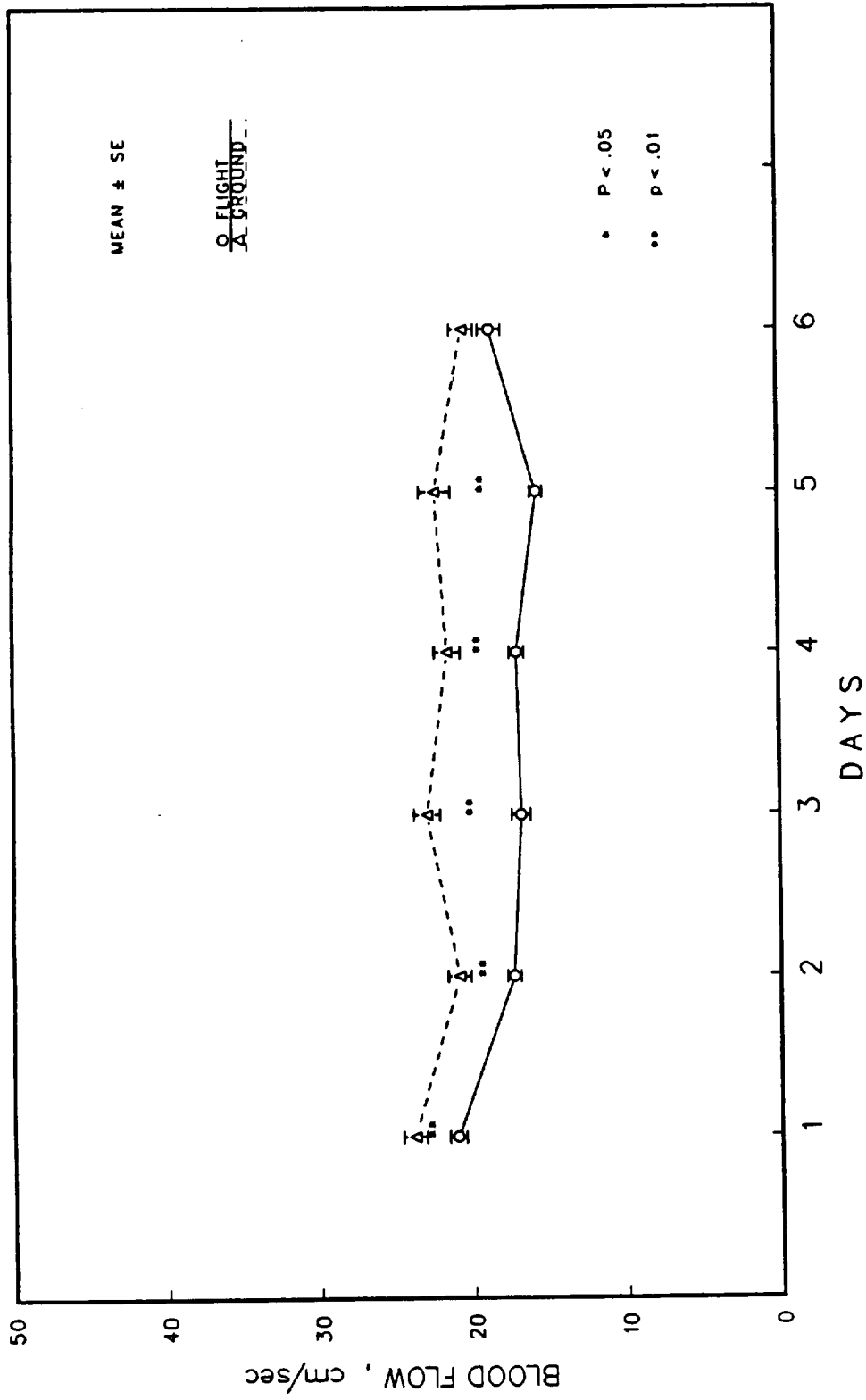

FIGURE II-N. COSMOS 1667 CARDIOVASCULAR EXPERIMENT  
GORDYY  
MIN CAROTID FLOW

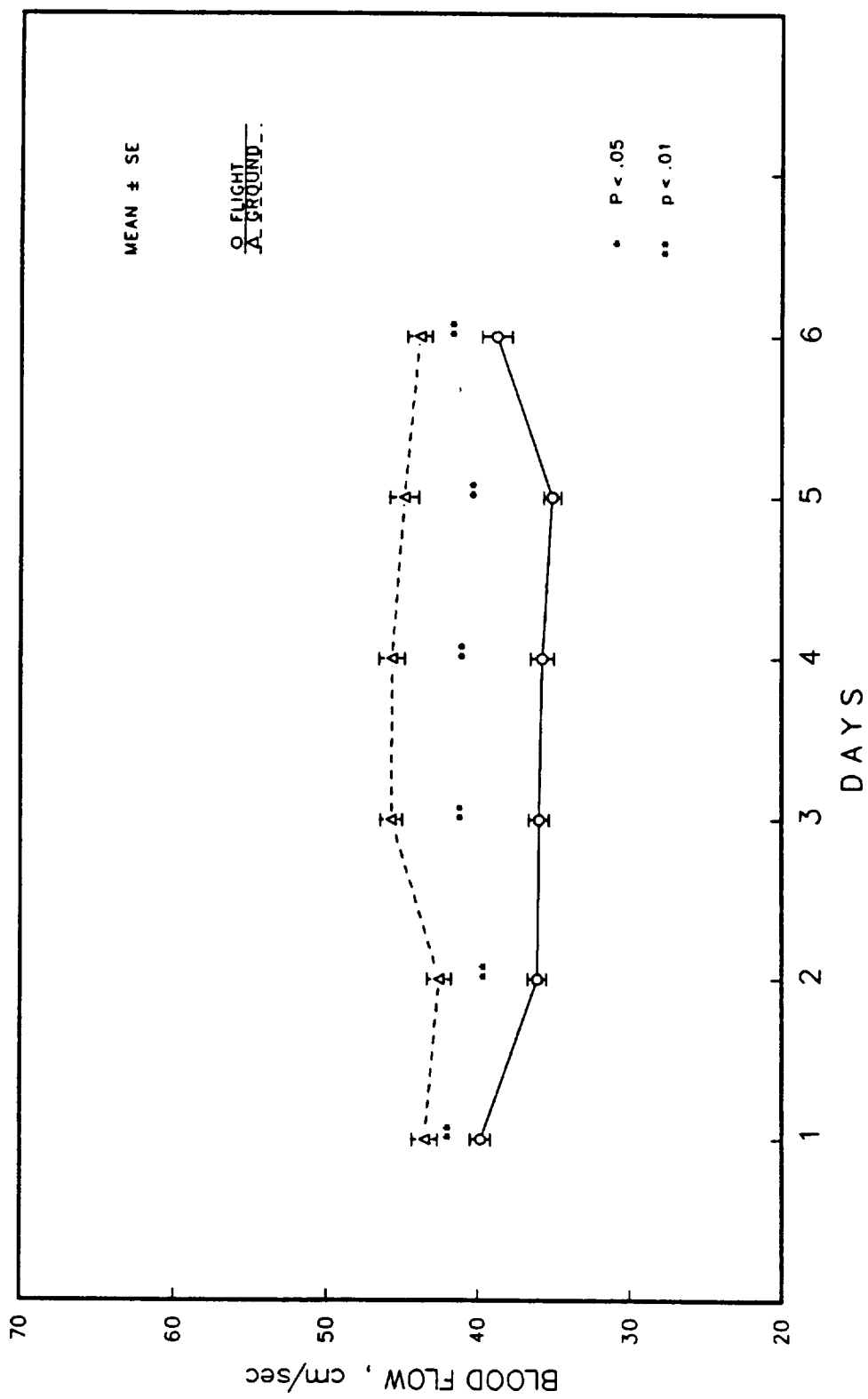

FIGURE II-O. COSMOS 1667 CARDIOVASCULAR EXPERIMENT  
GORDY  
MEAN CAROTID FLOW

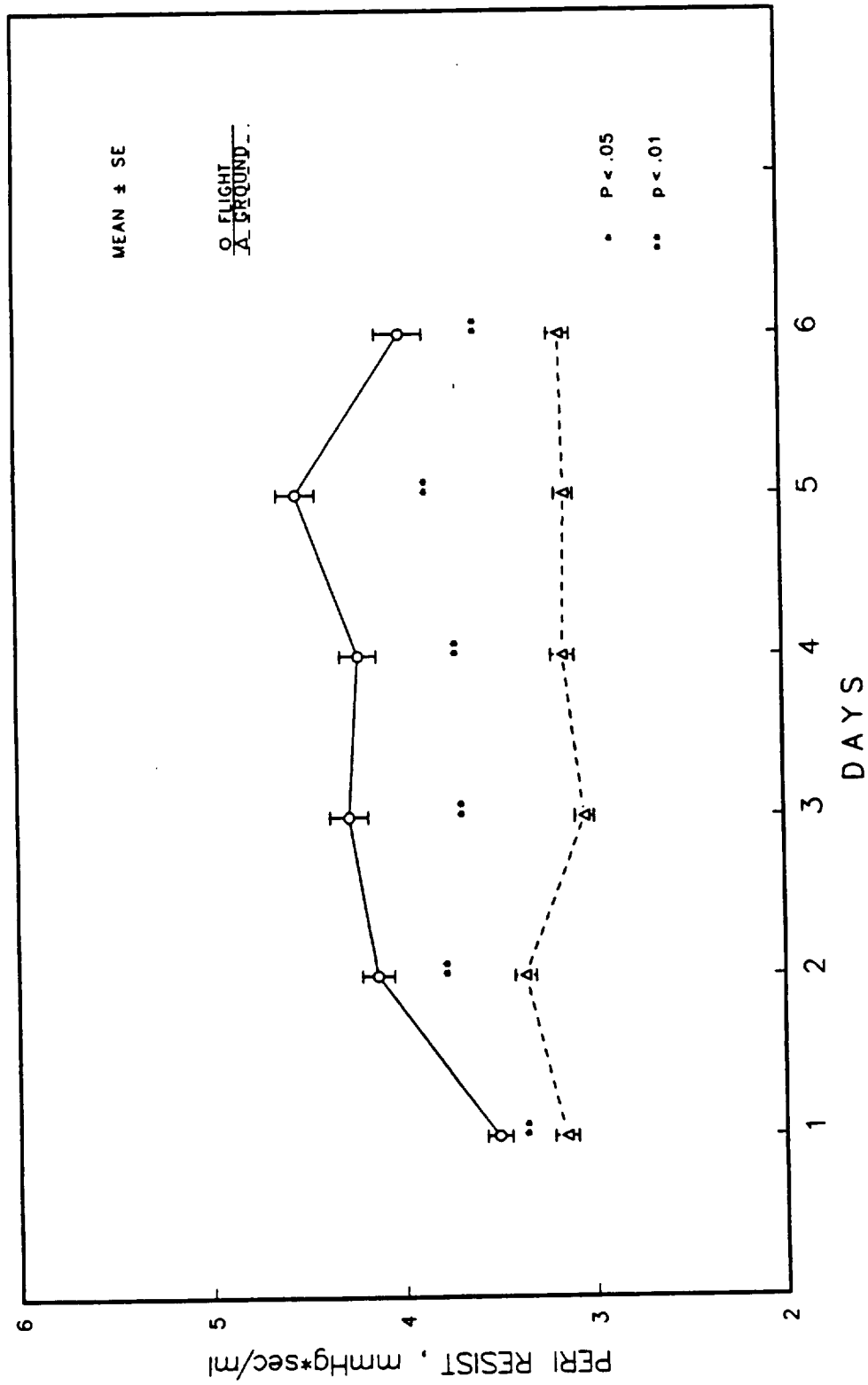

FIGURE II-P. COSMOS 1667 CARDIOVASCULAR EXPERIMENT  
GORDY  
PERIPHERAL RESISTANCE

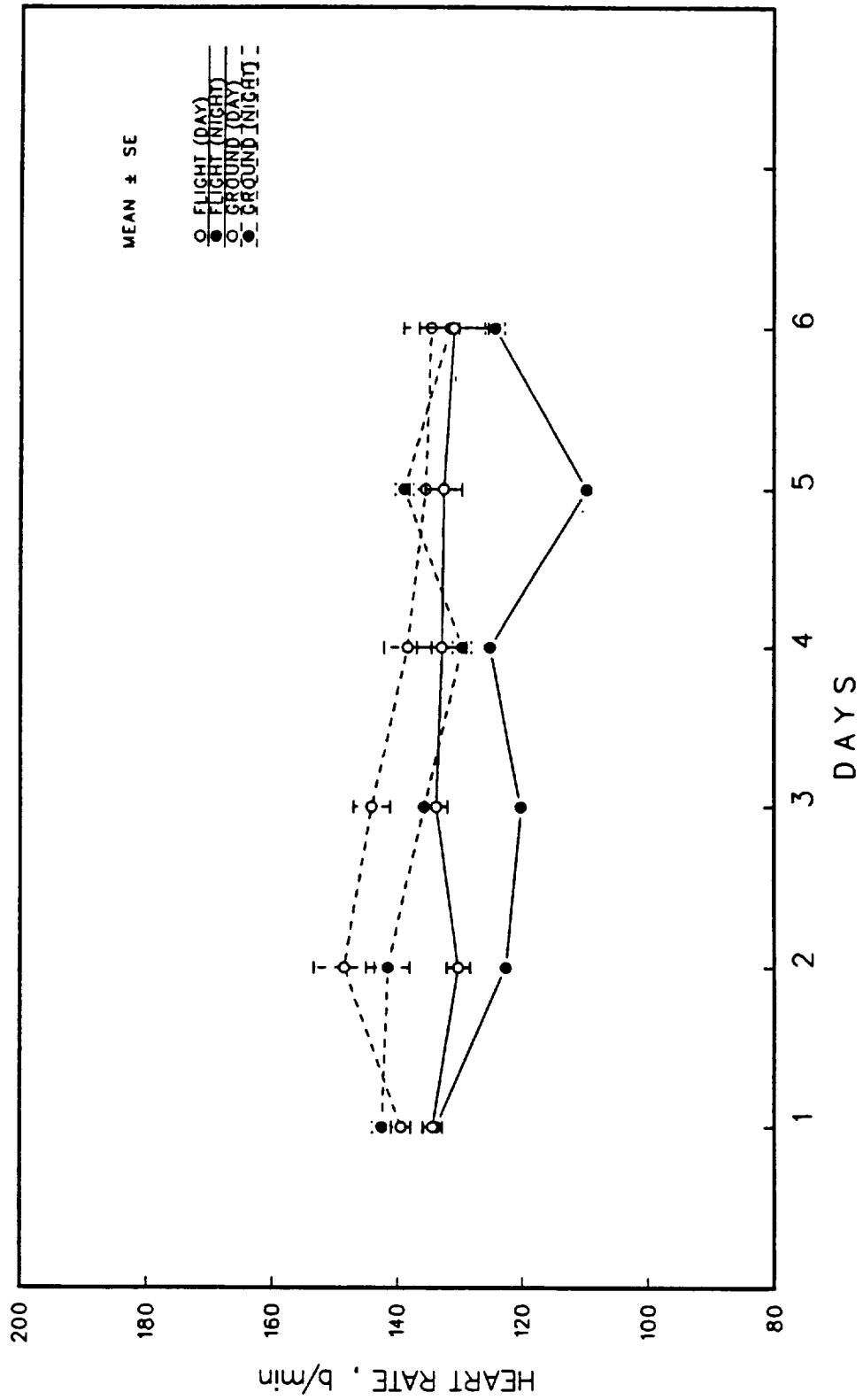

FIGURE III-A. COSMOS 1667 CARDIOVASCULAR EXPERIMENT

GORDY  
HEART RATE

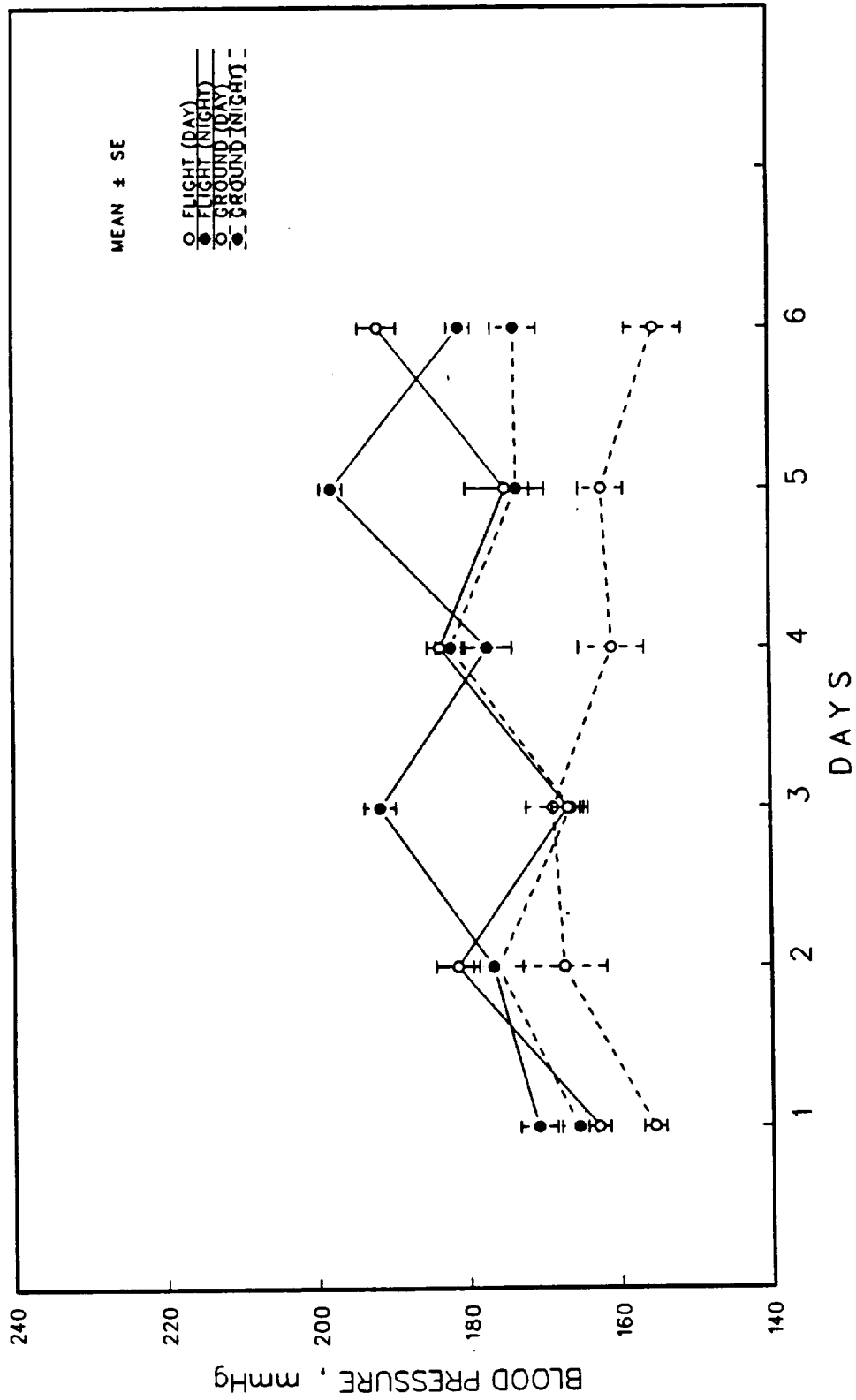

FIGURE III-B. COSMOS 1667 CARDIOVASCULAR EXPERIMENT  
 GORDYY  
 SYSTOLIC CAROTID PRESSURE

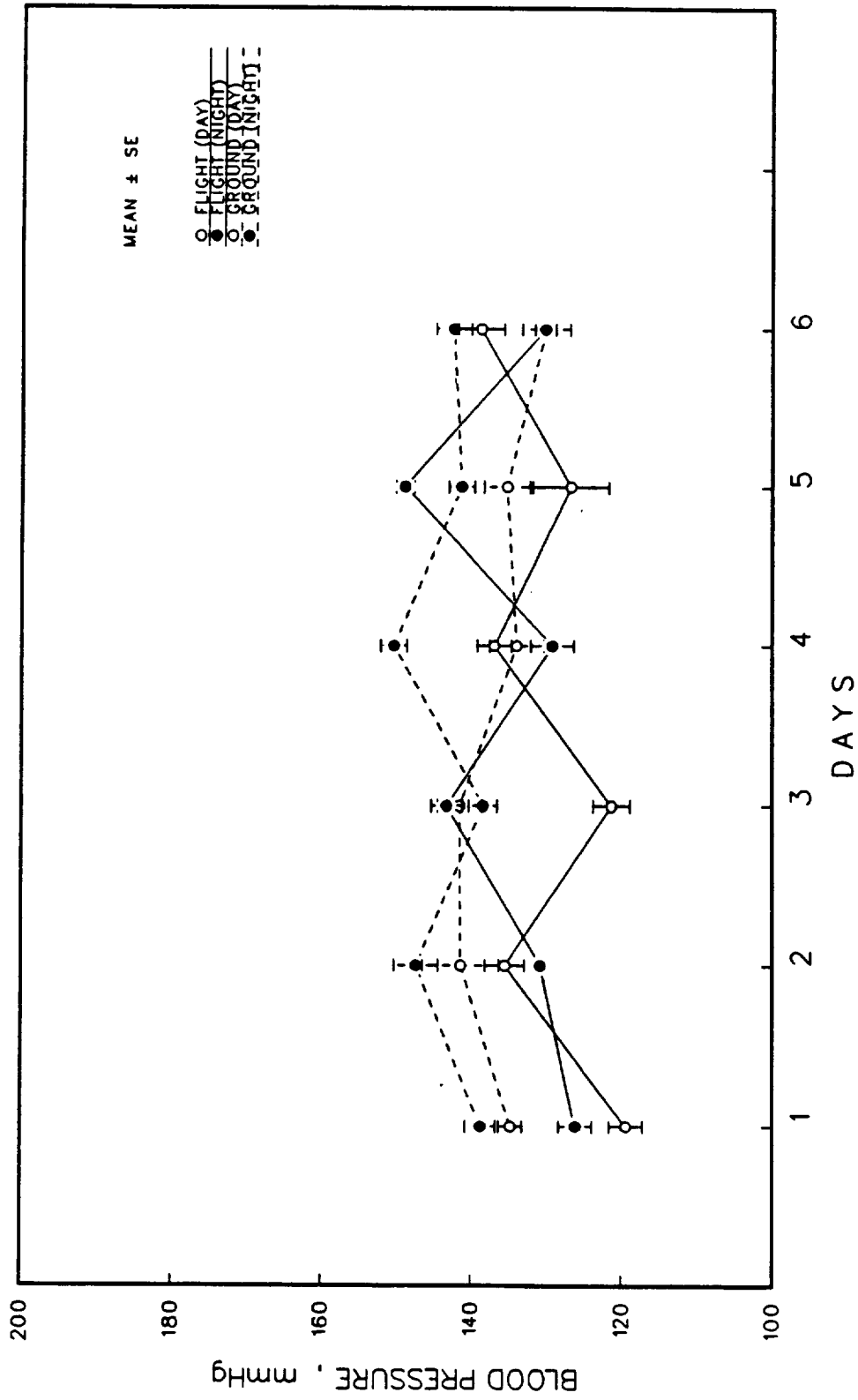

FIGURE III-C. COSMOS 1667 CARDIOVASCULAR EXPERIMENT  
 GORDY  
 DIASTOLIC CAROTID PRESSURE



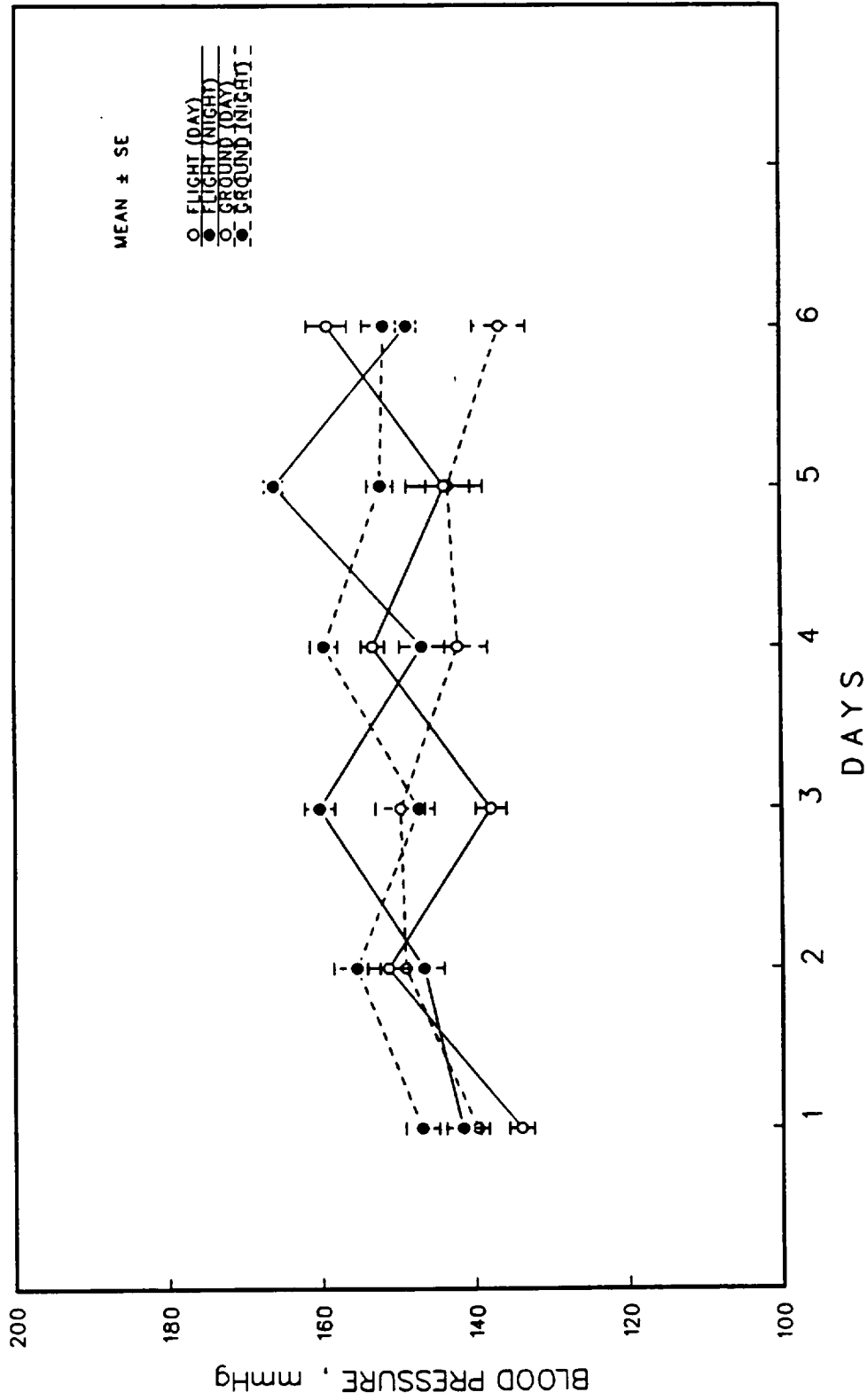

FIGURE III-D. COSMOS 1667 CARDIOVASCULAR EXPERIMENT  
 GORDY  
 MEAN CAROTID PRESSURE

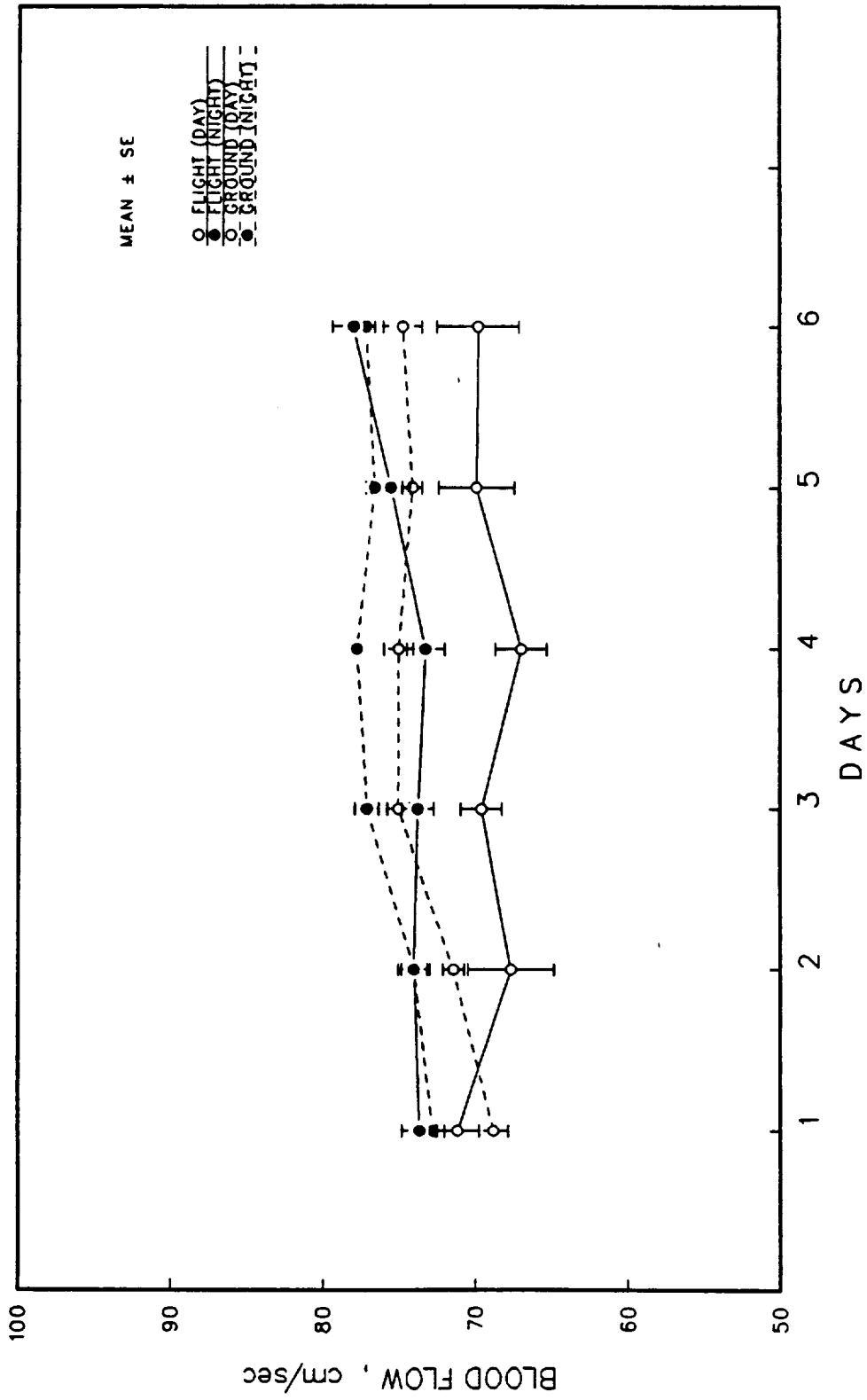

FIGURE III-E. COSMOS 1667 CARDIOVASCULAR EXPERIMENT  
 GORDYY  
 MAX CAROTID FLOW

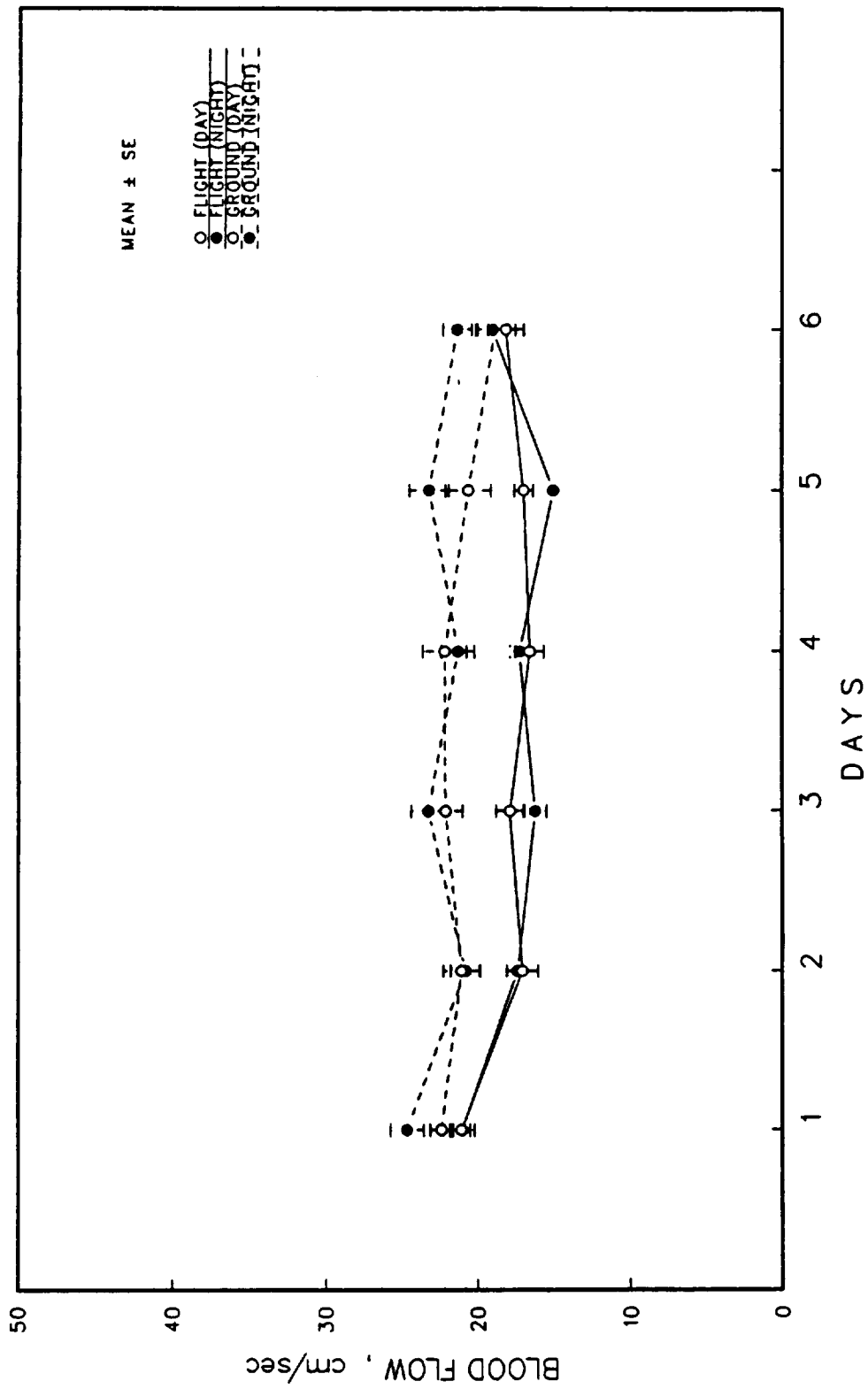

FIGURE III-F. COSMOS 1667 CARDIOVASCULAR EXPERIMENT  
 GORDYY  
 MIN CAROTID FLOW

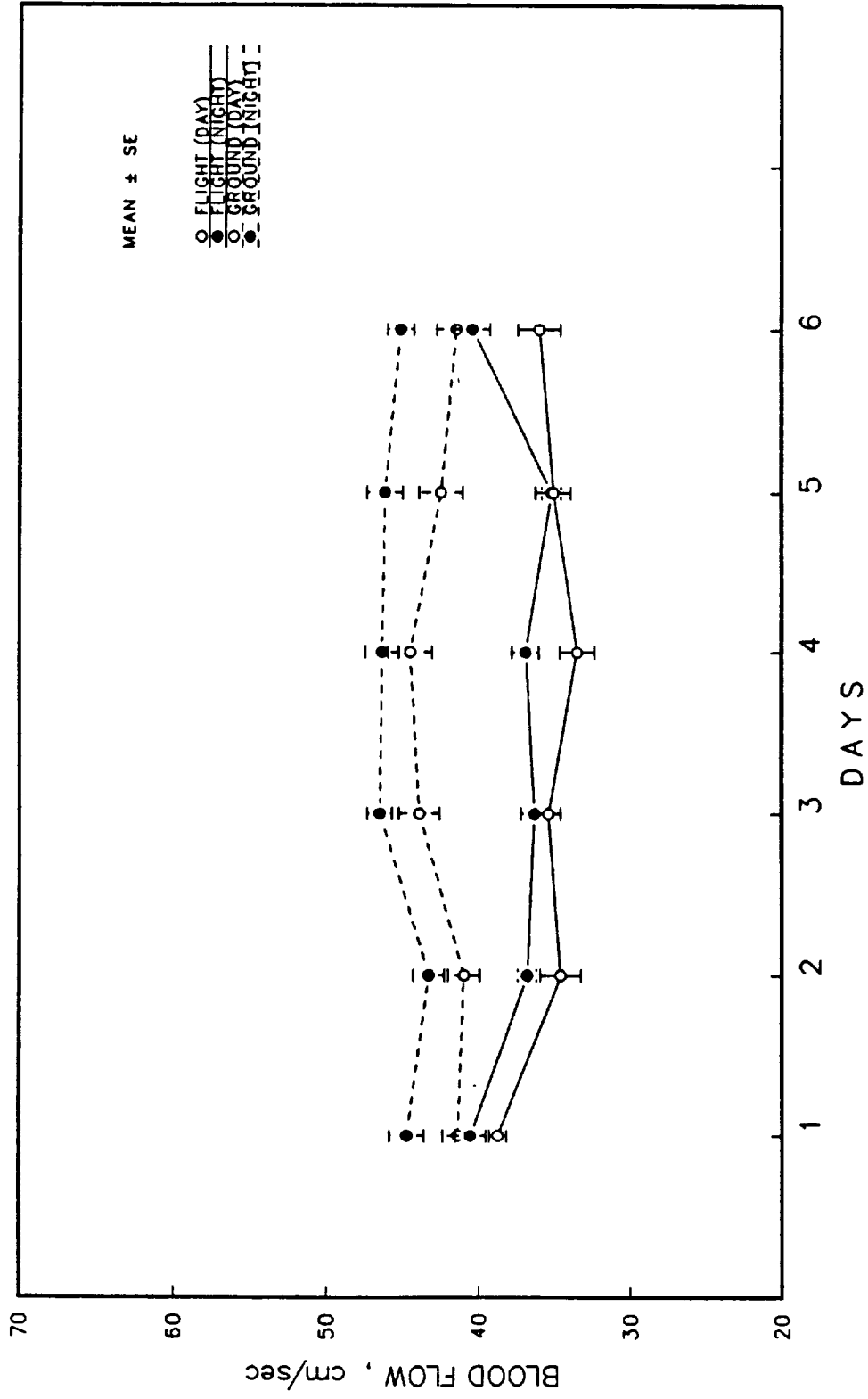

FIGURE III-G. COSMOS 1667 CARDIOVASCULAR EXPERIMENT  
 GORDY  
 MEAN CAROTID FLOW

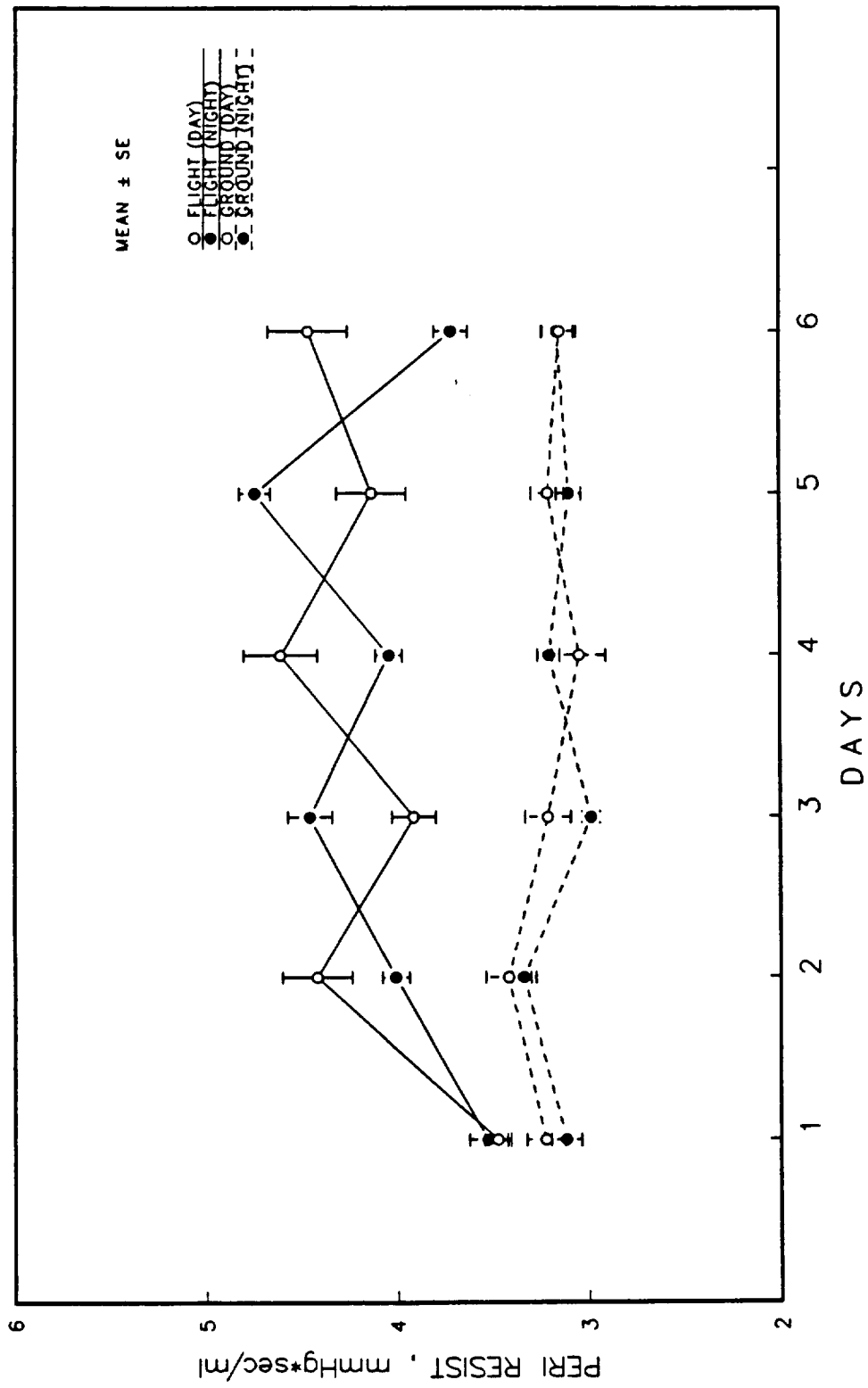

FIGURE III-H. COSMOS 1667 CARDIOVASCULAR EXPERIMENT  
 GORDY  
PERIPHERAL RESISTANCE

GORDYY  
SAMURAI  
LIGHT OFF

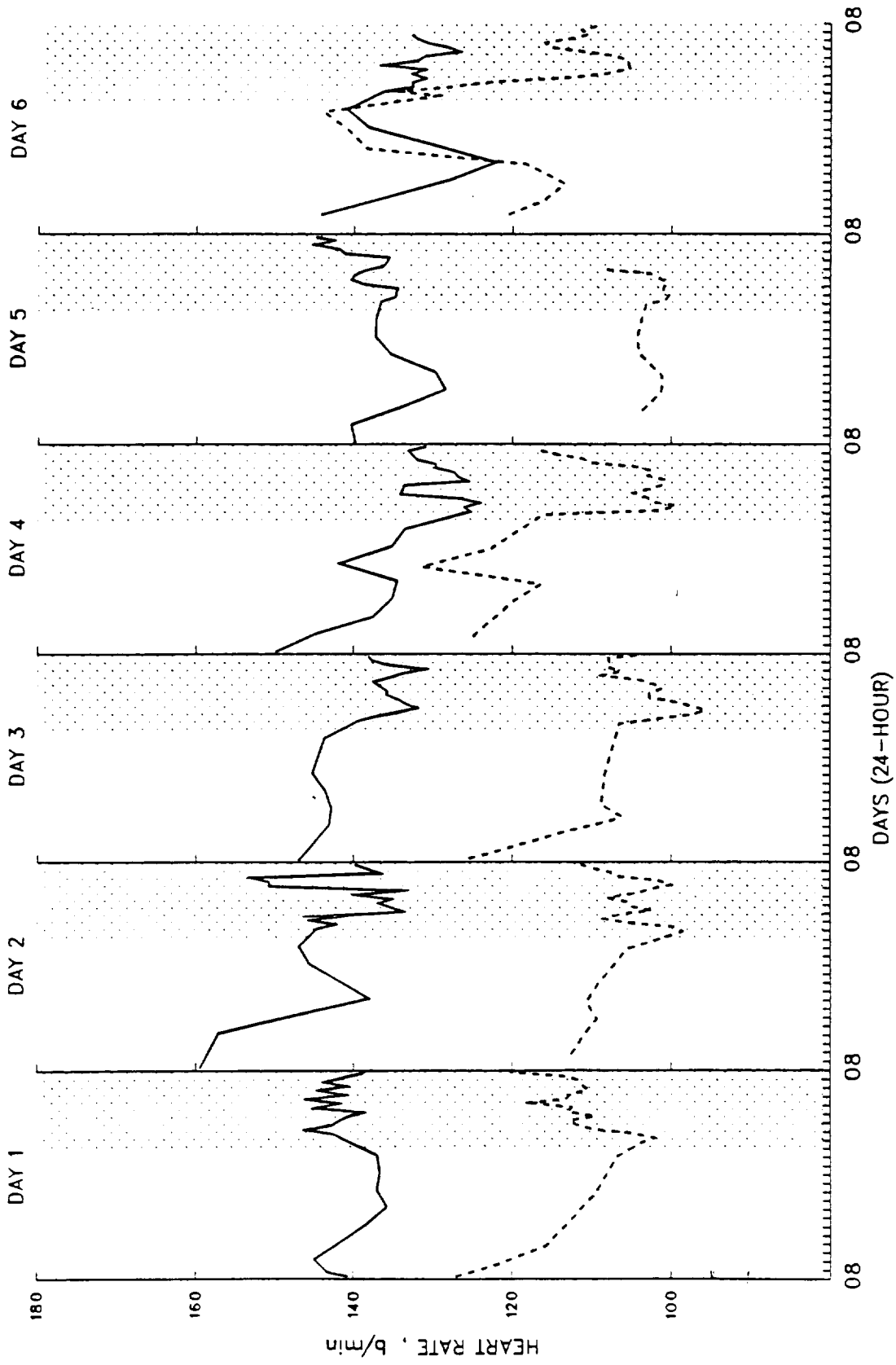

FIGURE IV-A. COSMOS 1667 CARDIOVASCULAR EXPERIMENT  
POSTFLIGHT CONTROLS (GORDYY, SAMURAI)  
HEART RATE

GORDY  
 SAMURAI  
 LIGHT OFF

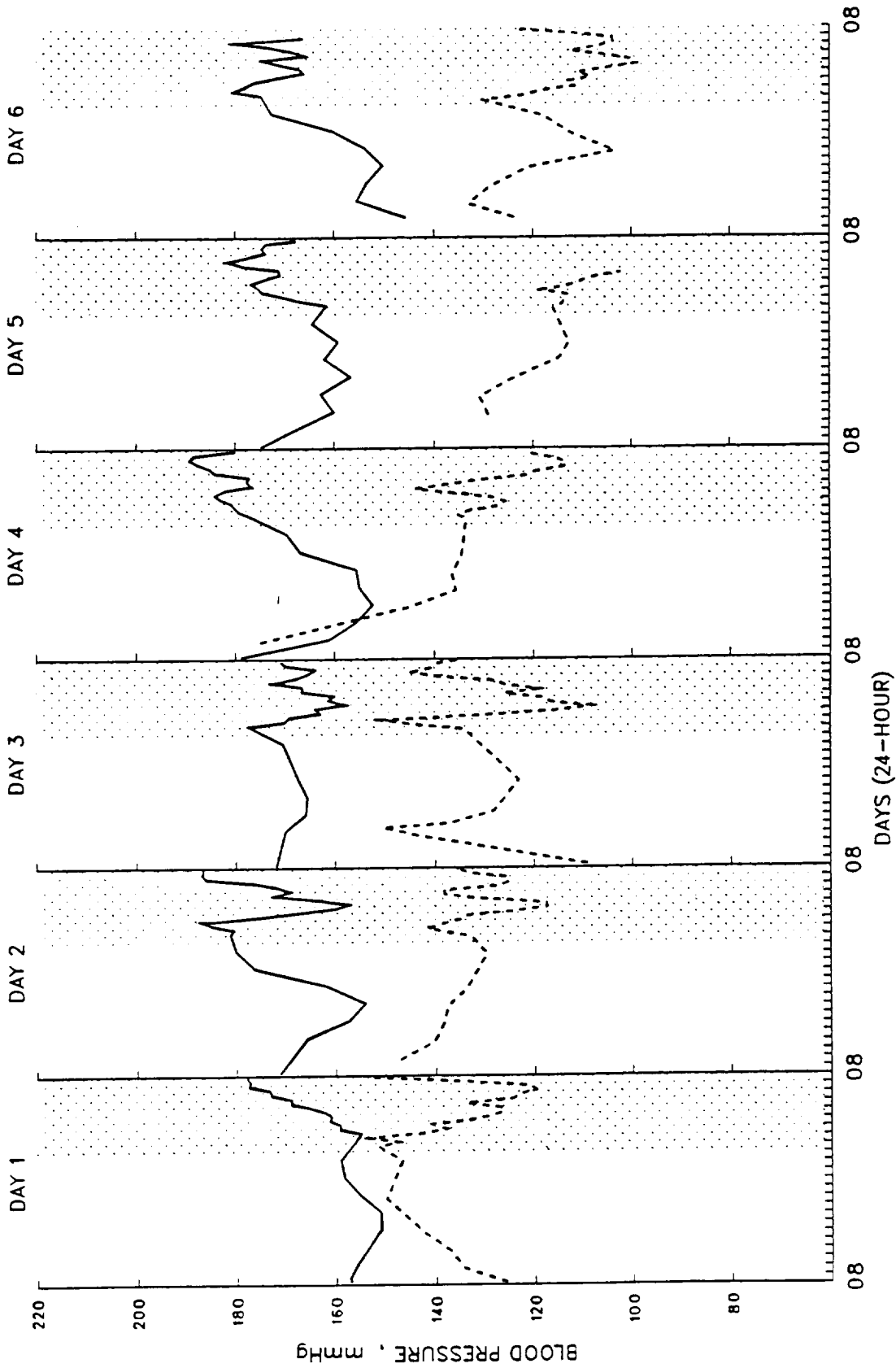

FIGURE IV-B. COSMOS 1667 CARDIOVASCULAR EXPERIMENT  
 POSTFLIGHT CONTROLS (GORDY, SAMURAI)  
 SYSTOLIC CAROTID PRESSURE

GORDYY  
SAMURAI  
LIGHT OFF

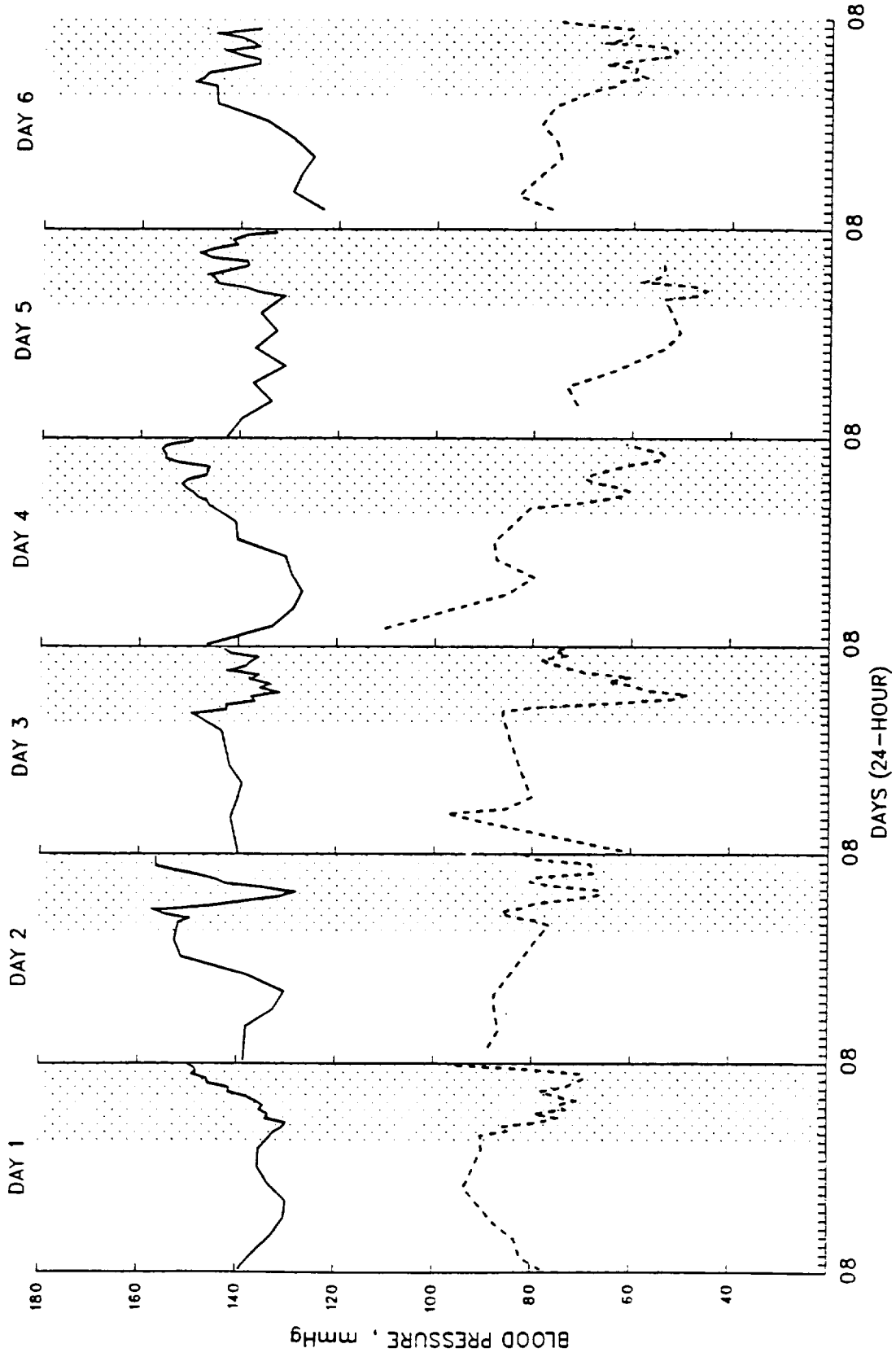

FIGURE IV-C. COSMOS 1667 CARDIOVASCULAR EXPERIMENT  
POSTFLIGHT CONTROLS (GORDYY, SAMURAI)  
DIASTOLIC CAROTID PRESSURE



GORDYY  
 SAMURAI  
 LIGHT OFF

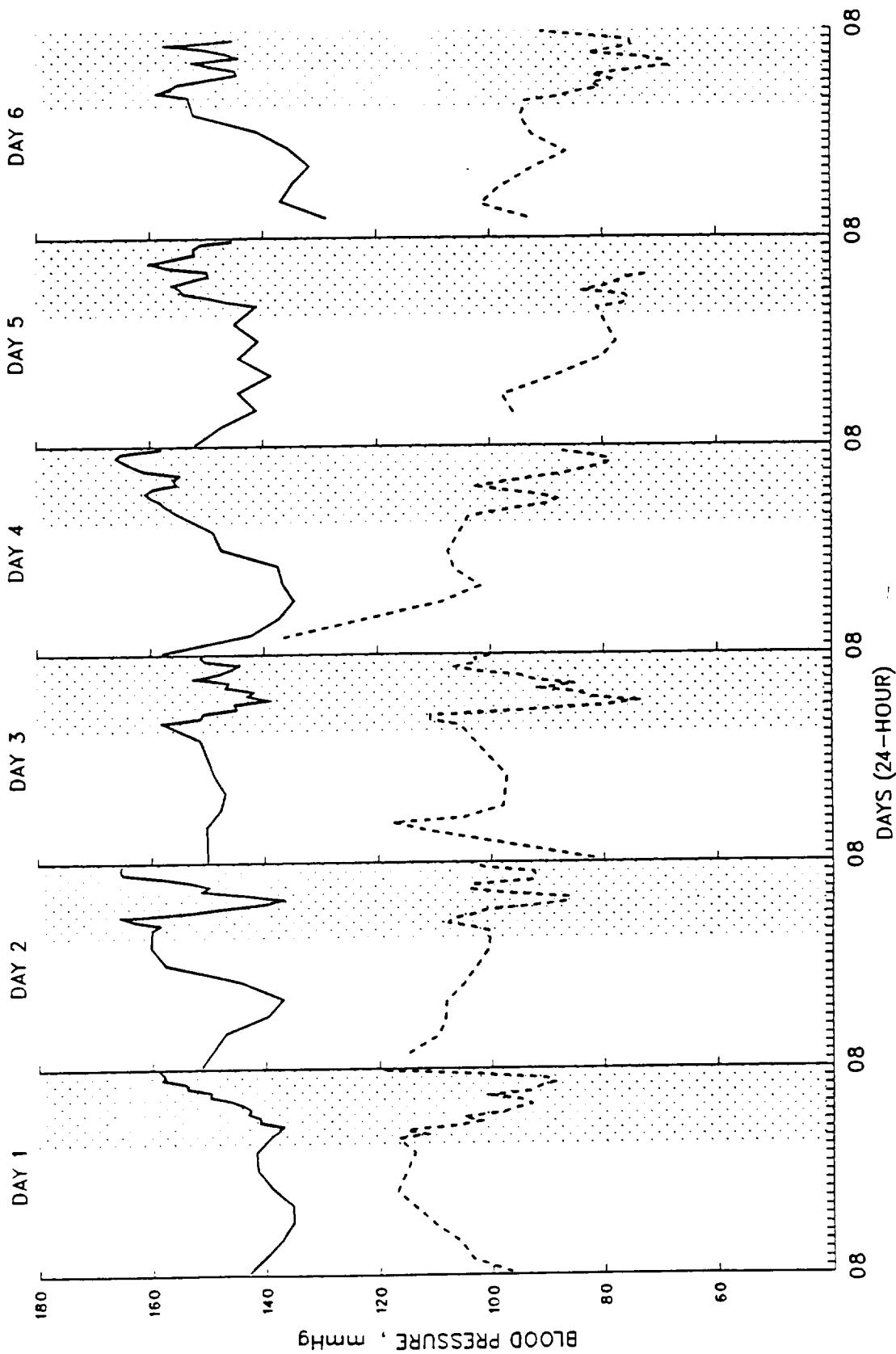

FIGURE IV-D. COSMOS 1667 CARDIOVASCULAR EXPERIMENT  
 POSTFLIGHT CONTROLS (GORDYY, SAMURAI)  
 MEAN CAROTID PRESSURE

GORDYY  
SAMURAI  
LIGHT OFF

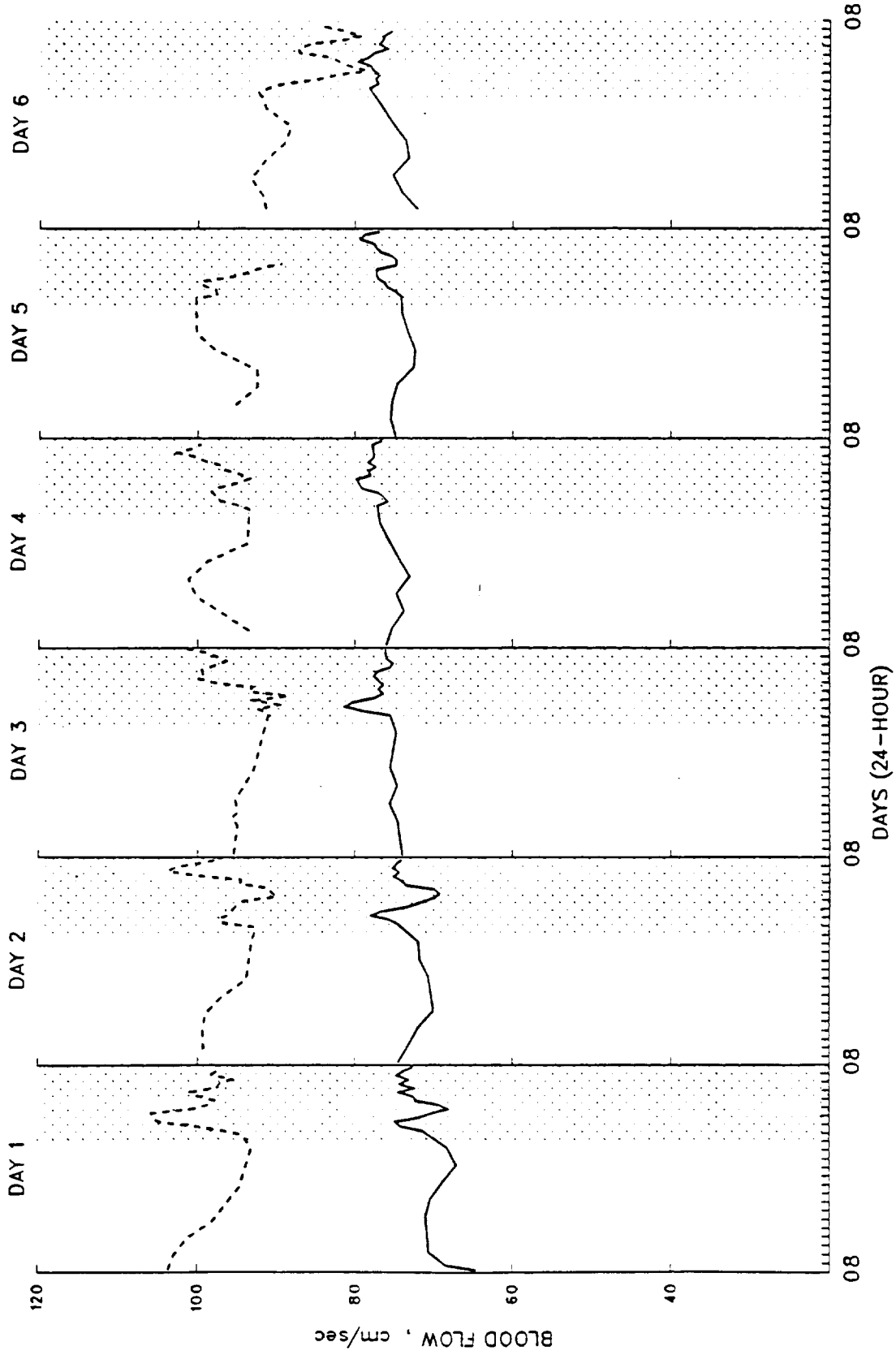

FIGURE IV-E. COSMOS 1667 CARDIOVASCULAR EXPERIMENT  
POSTFLIGHT CONTROLS (GORDYY, SAMURAI)  
MAX CAROTID FLOW

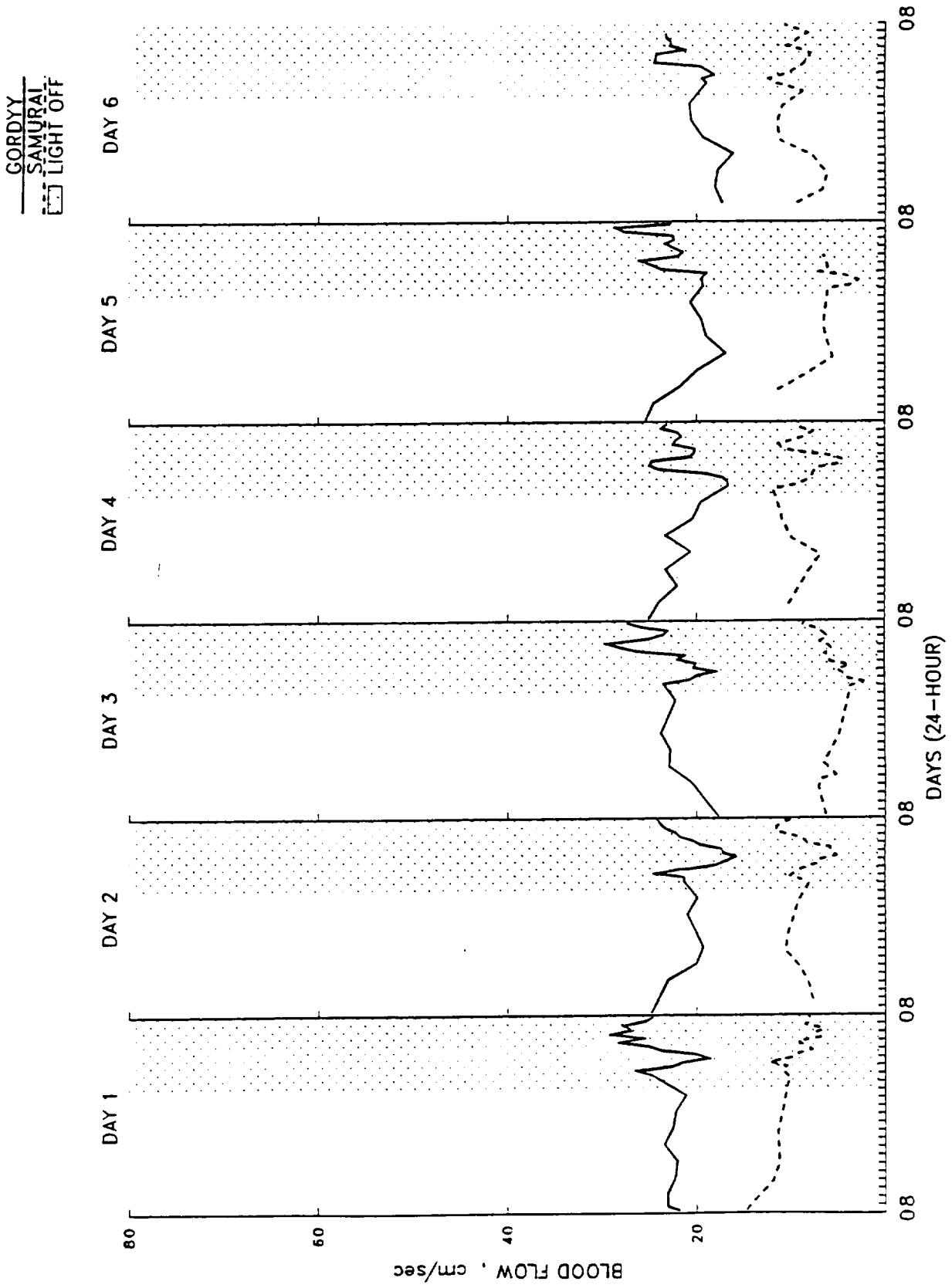

FIGURE IV-F. COSMOS 1667 CARDIOVASCULAR EXPERIMENT  
 POSTFLIGHT CONTROLS (GORDYY, SAMURAI)  
MIN CAROTID FLOW

GORDYY  
SAMURAI  
LIGHT OFF

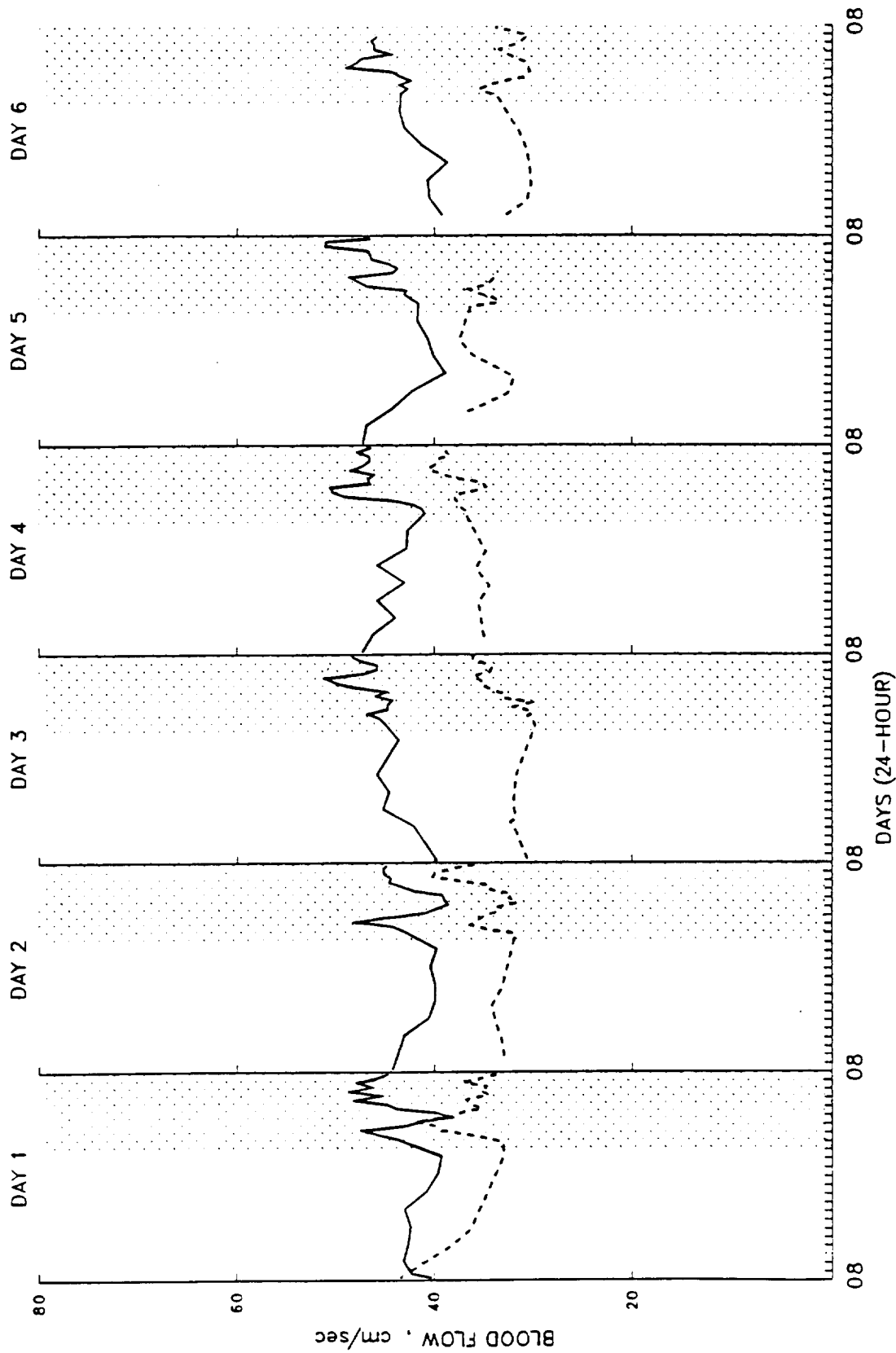

FIGURE IV-G. COSMOS 1667 CARDIOVASCULAR EXPERIMENT  
POSTFLIGHT CONTROLS (GORDYY, SAMURAI)  
MEAN CAROTID FLOW

GORDY  
 SAMURAI  
 LIGHT OFF

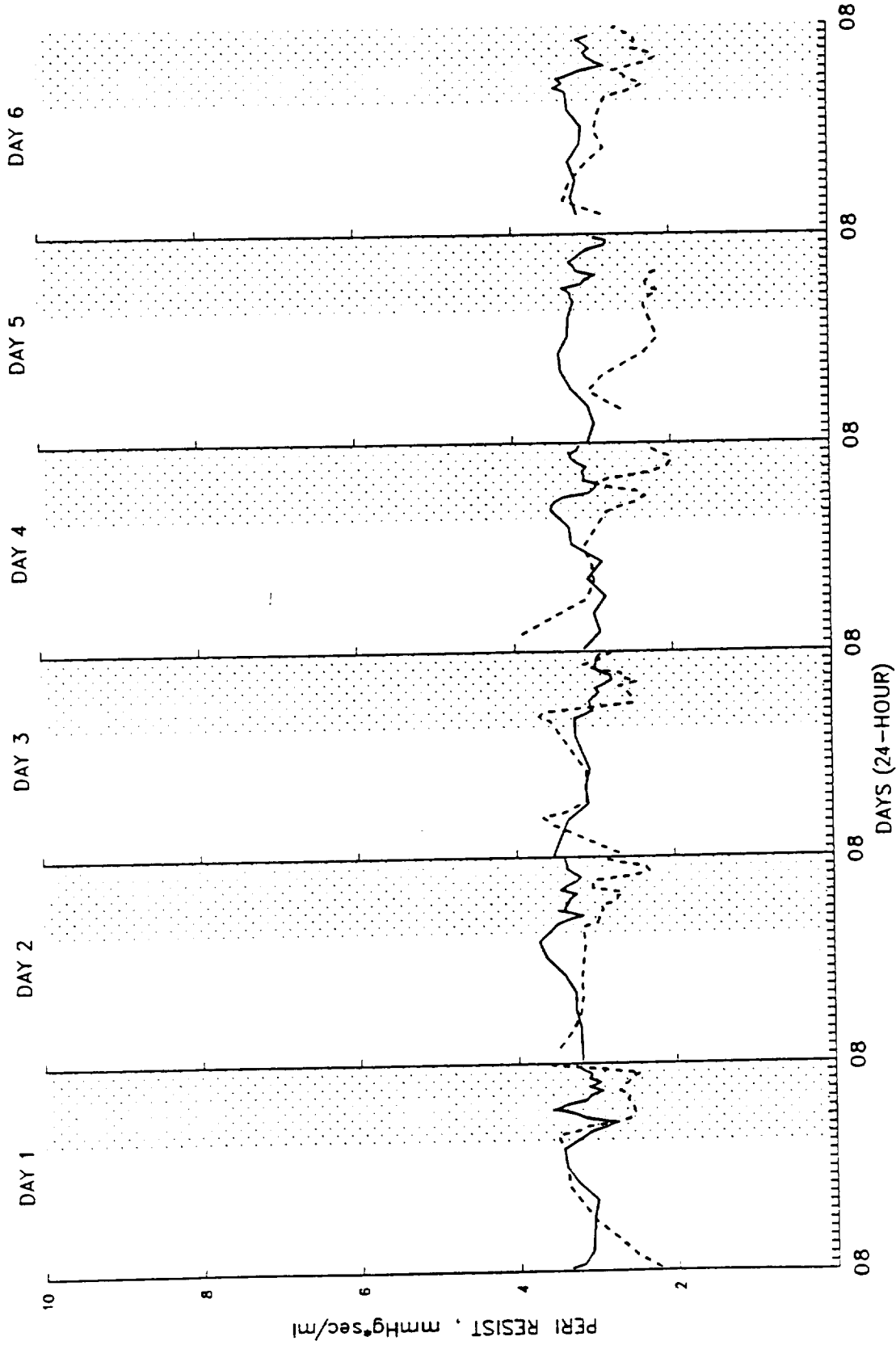

FIGURE IV-H. COSMOS 1667 CARDIOVASCULAR EXPERIMENT  
 POSTFLIGHT CONTROLS (GORDY, SAMURAI)  
PERIPHERAL RESISTANCE

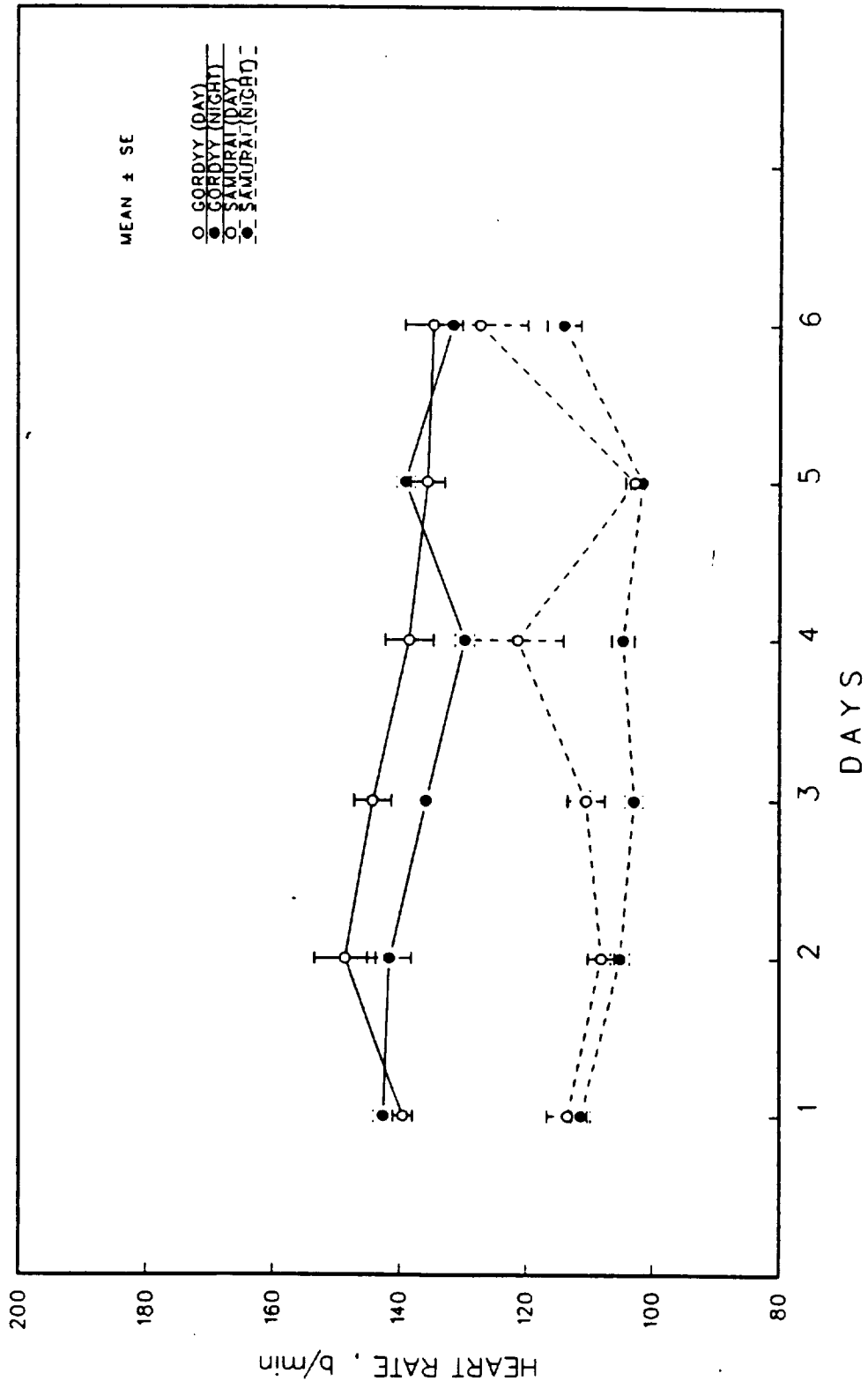

FIGURE IV-1. COSMOS 1667 CARDIOVASCULAR EXPERIMENT  
 POSTFLIGHT CONTROLS (GORDYY, SAMURAI)  
 HEART RATE

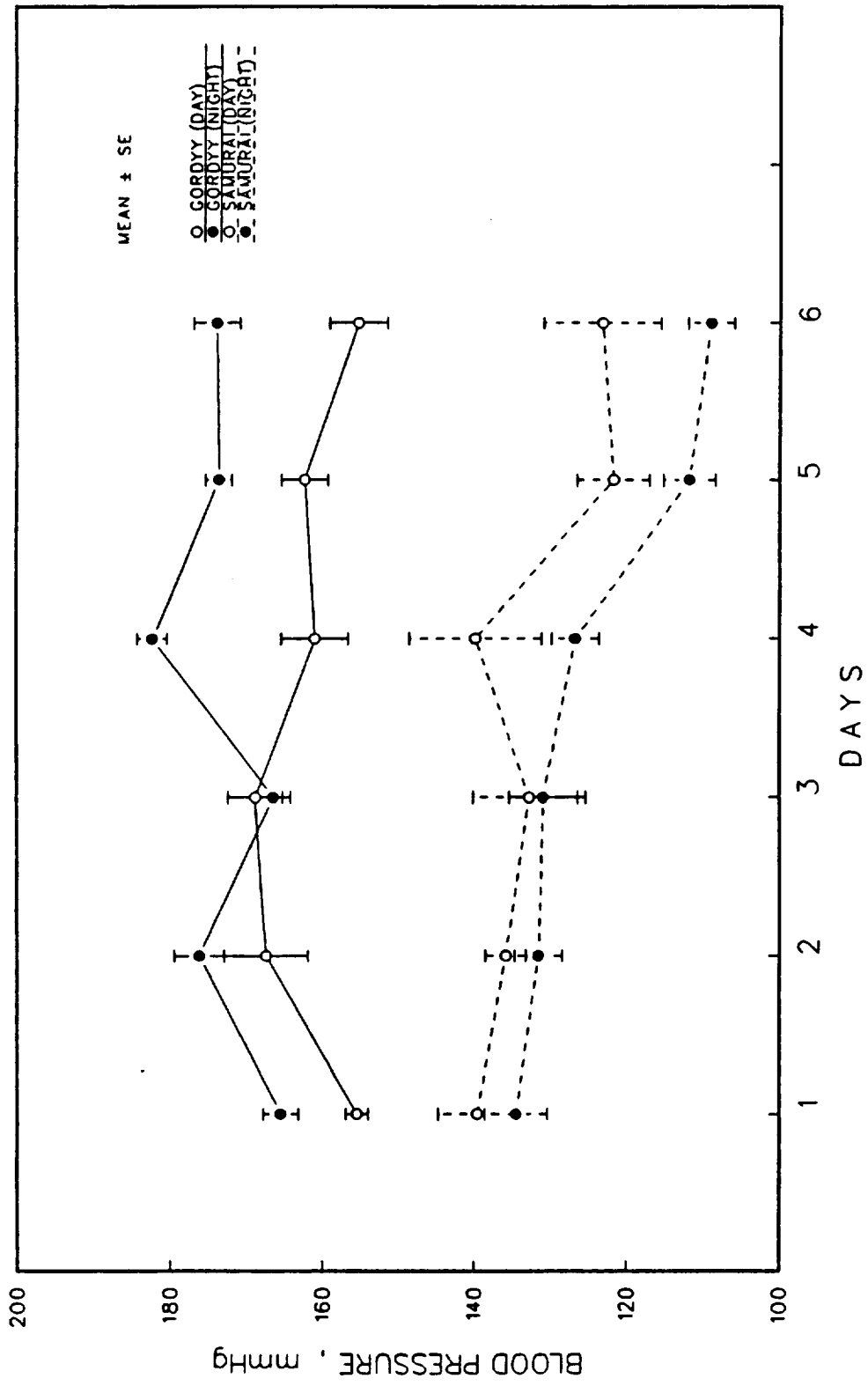

FIGURE IV-J. COSMOS 1667 CARDIOVASCULAR EXPERIMENT  
 POSTFLIGHT CONTROLS (GORDYY, SAMURAI)  
 SYSTOLIC CAROTID PRESSURE

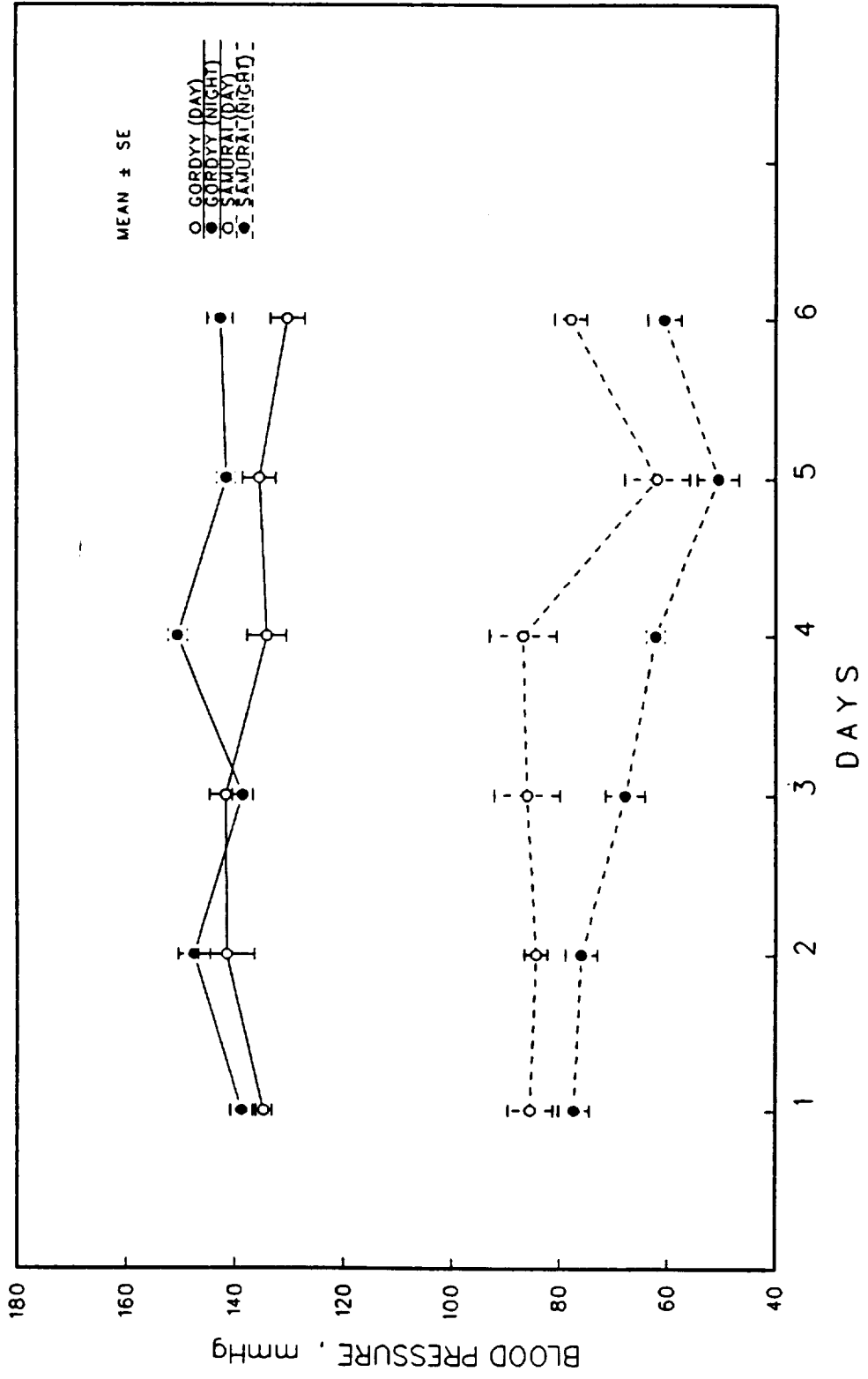

FIGURE IV-K. COSMOS 1667 CARDIOVASCULAR EXPERIMENT  
 POSTFLIGHT CONTROLS (GORDYY, SAMURAI)  
 DIASTOLIC CAROTID PRESSURE



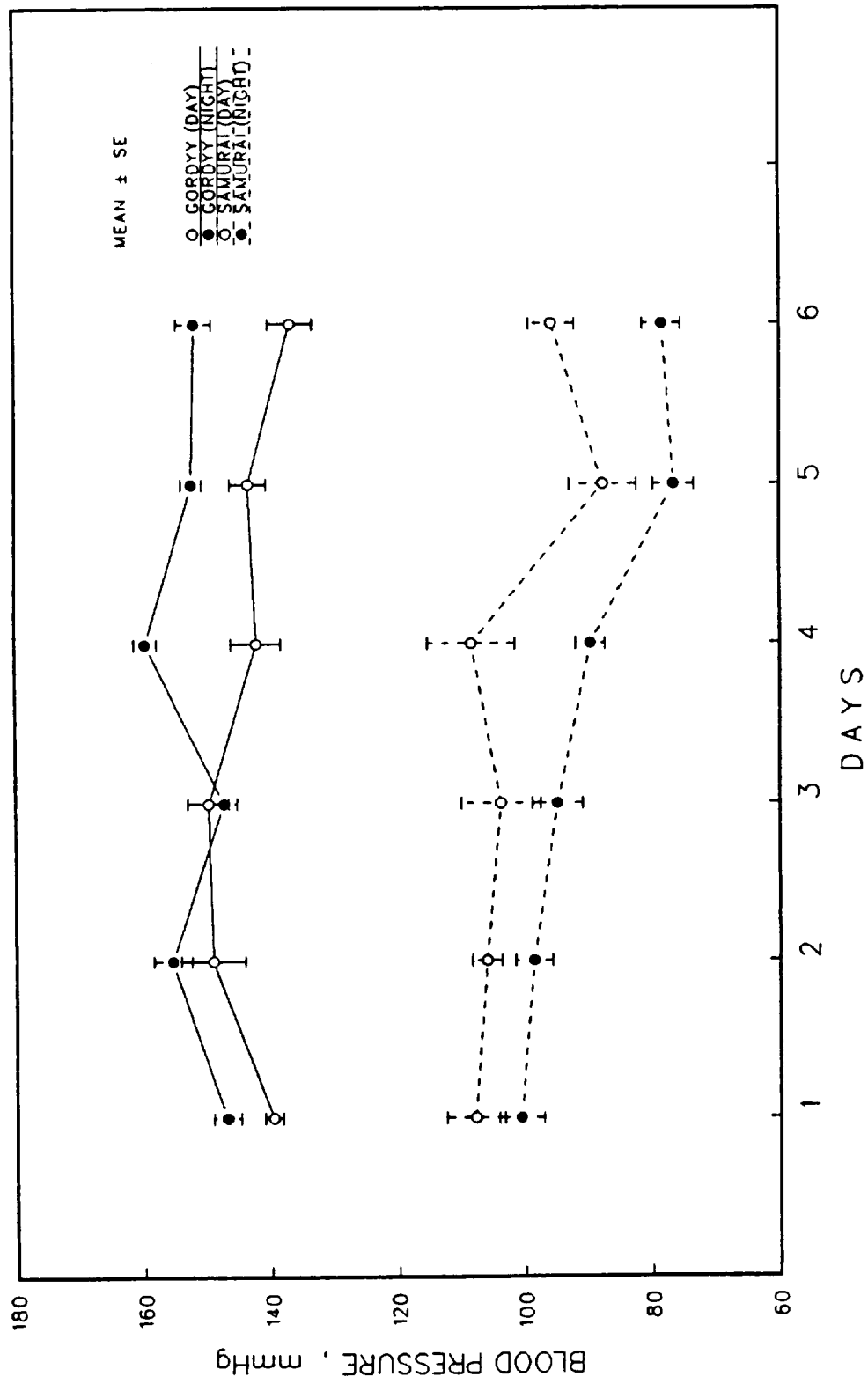

FIGURE IV-L. COSMOS 1667 CARDIOVASCULAR EXPERIMENT  
 POSTFLIGHT CONTROLS (GORDYY, SAMURAI)  
 MEAN CAROTID PRESSURE

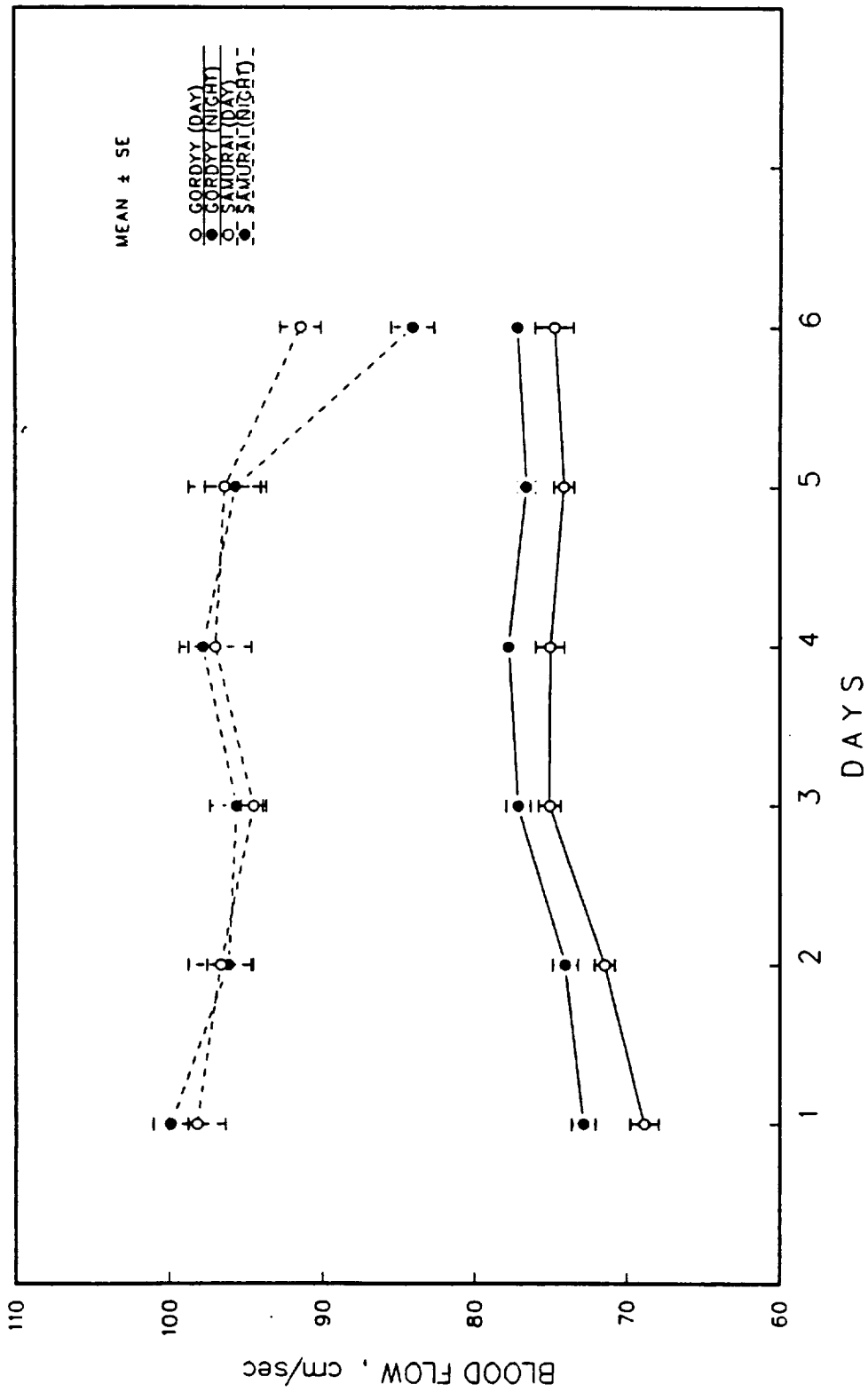

FIGURE IV-M. COSMOS 1667 CARDIOVASCULAR EXPERIMENT  
 POSTFLIGHT CONTROLS (GORDYY, SAMURAI)  
 MAX CAROTID FLOW

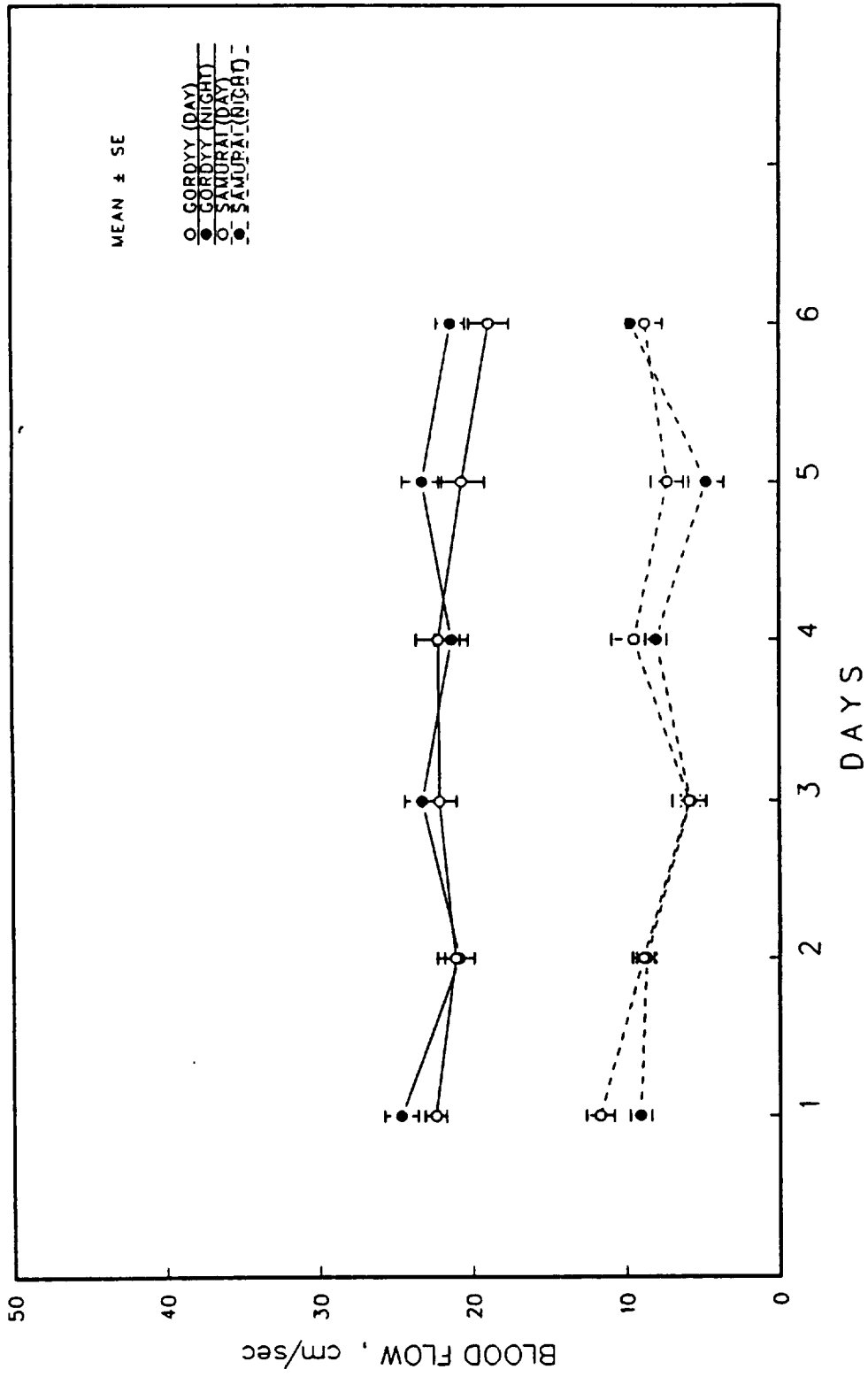

FIGURE IV-N. COSMOS 1667 CARDIOVASCULAR EXPERIMENT  
 POSTFLIGHT CONTROLS (GORDYY, SAMURAI)  
MIN CAROTID FLOW

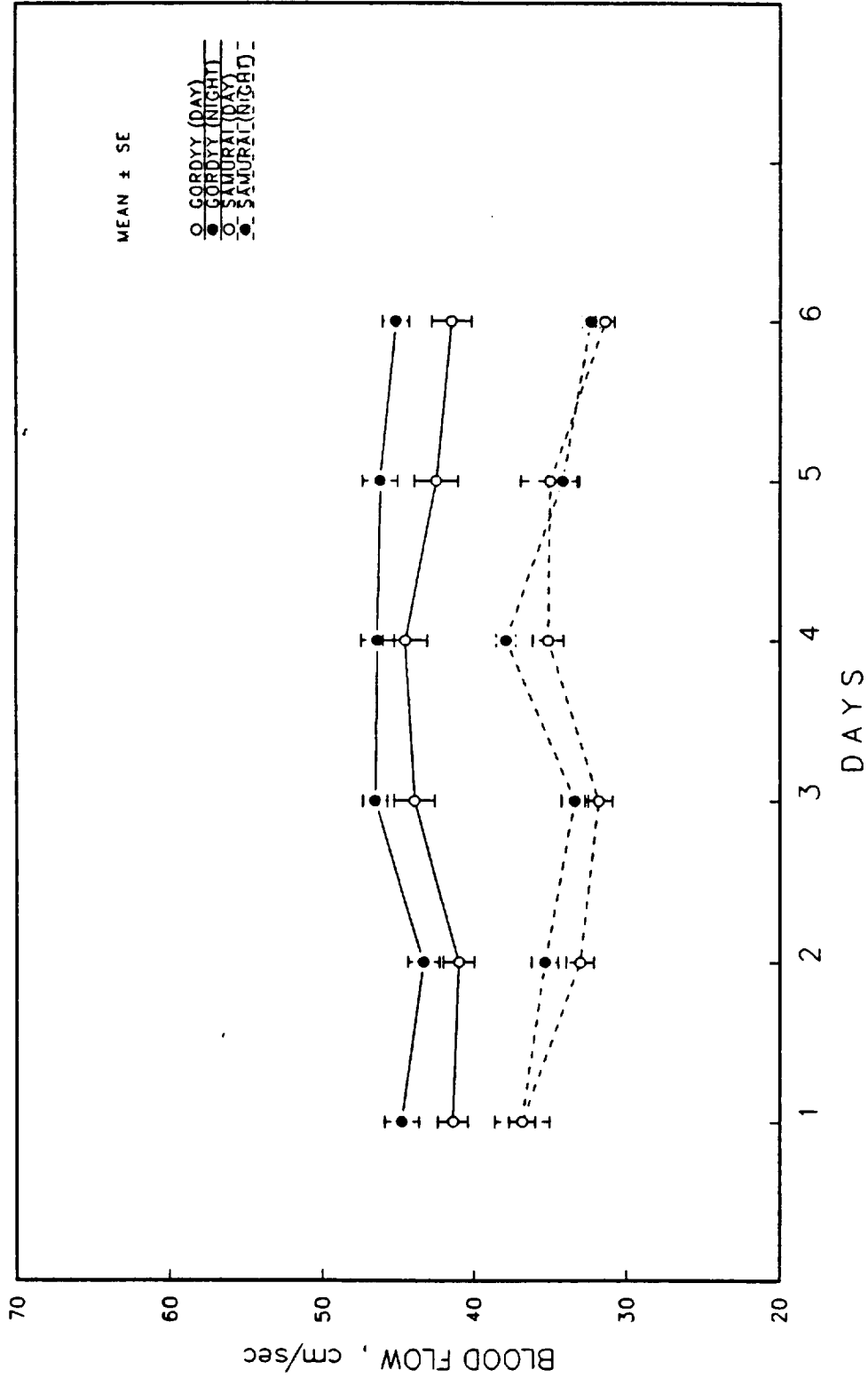

FIGURE IV-O. COSMOS 1667 CARDIOVASCULAR EXPERIMENT  
 POSTFLIGHT CONTROLS (GORDYY, SAMURAI)  
 MEAN CAROTID FLOW

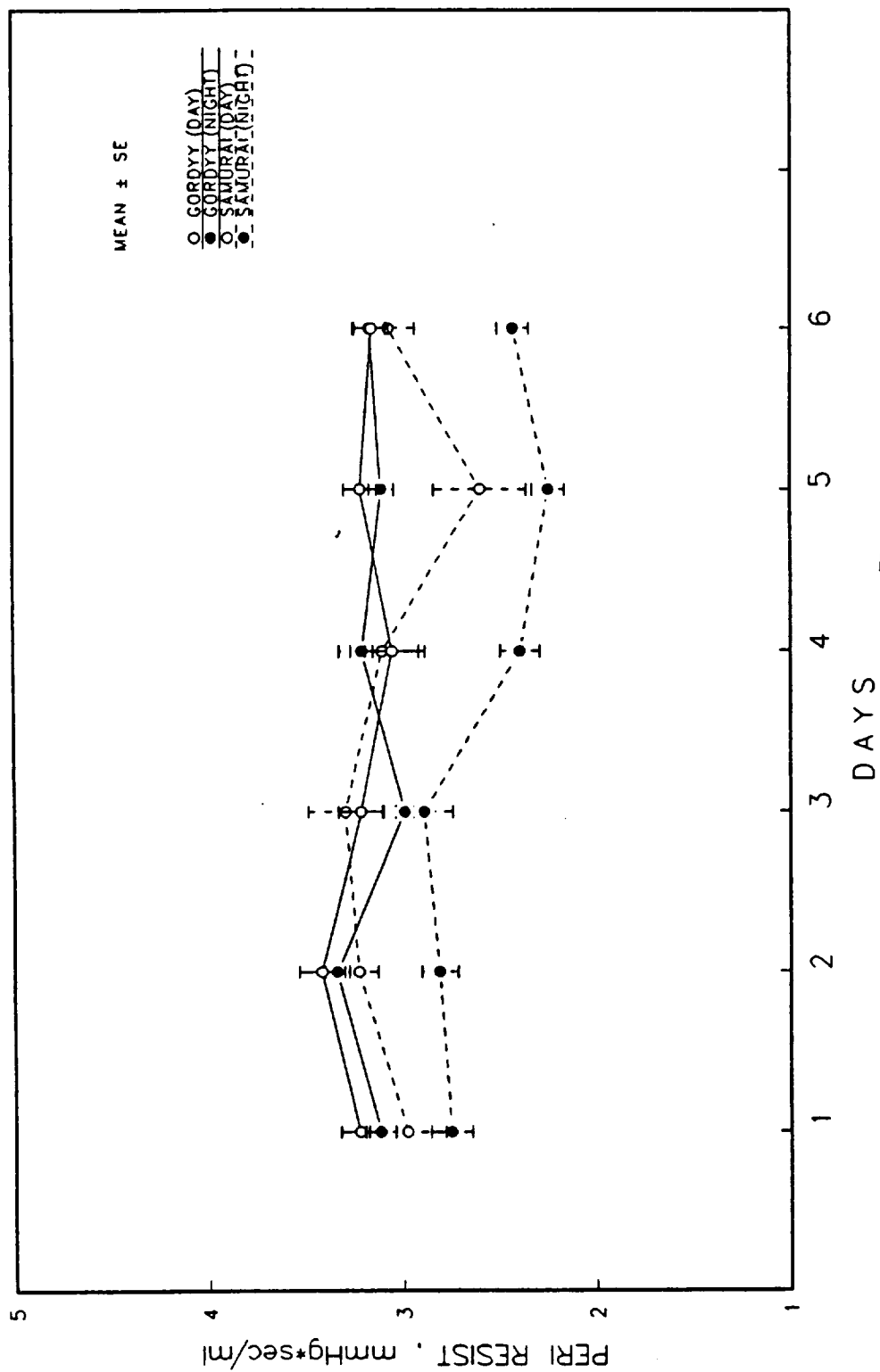

FIGURE IV-P. COSMOS 1667 CARDIOVASCULAR EXPERIMENT  
 POSTFLIGHT CONTROLS (GORDY, SAMURAI)  
 PERIPHERAL RESISTANCE

GORDYY  
KVAK  
LIGHT OFF

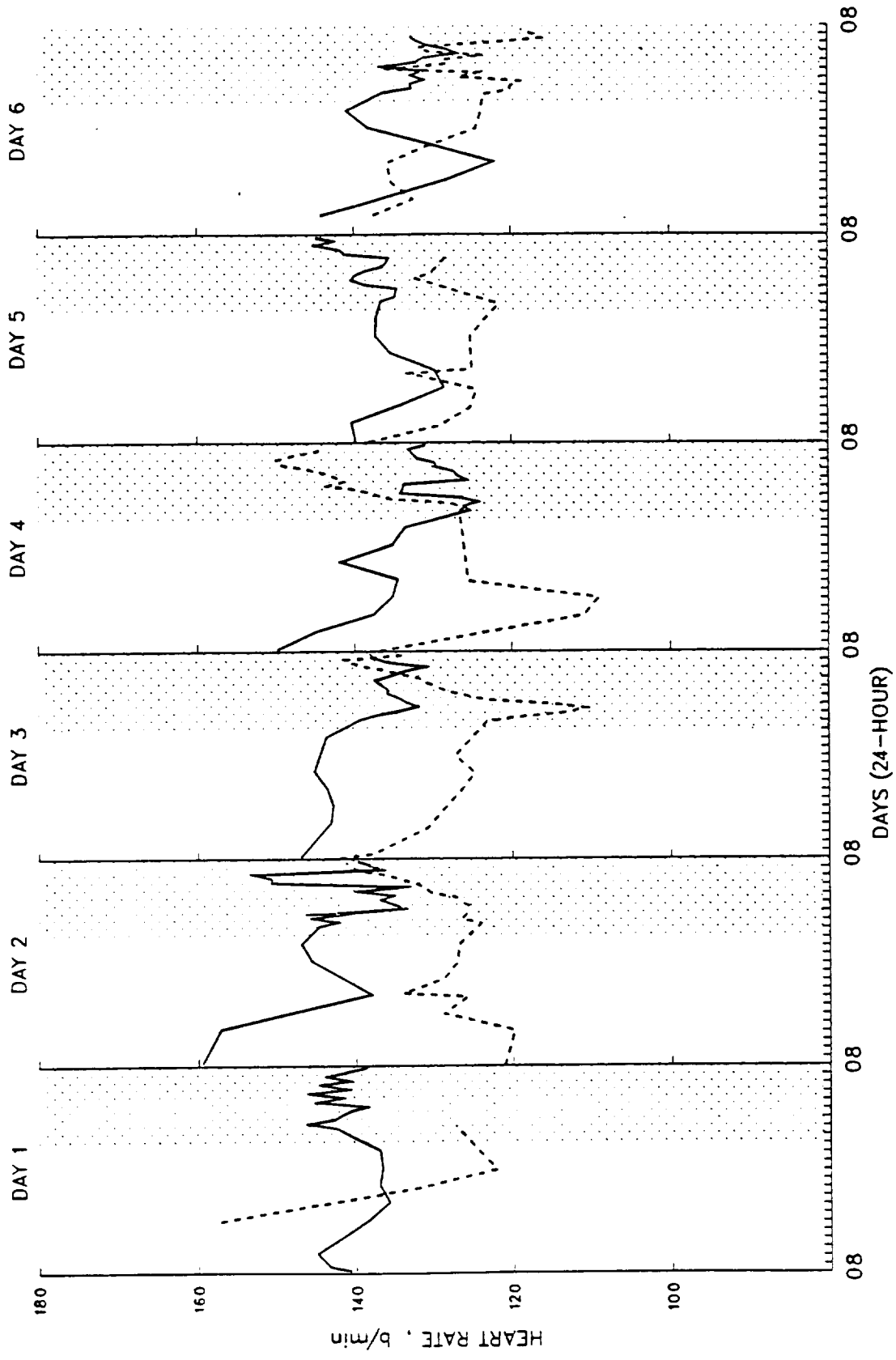

FIGURE IV-Q. COSMOS 1667 CARDIOVASCULAR EXPERIMENT  
POSTFLIGHT CONTROLS (GORDYY, KVAK)  
HEART RATE

GORDYY  
KVAK  
LIGHT OFF

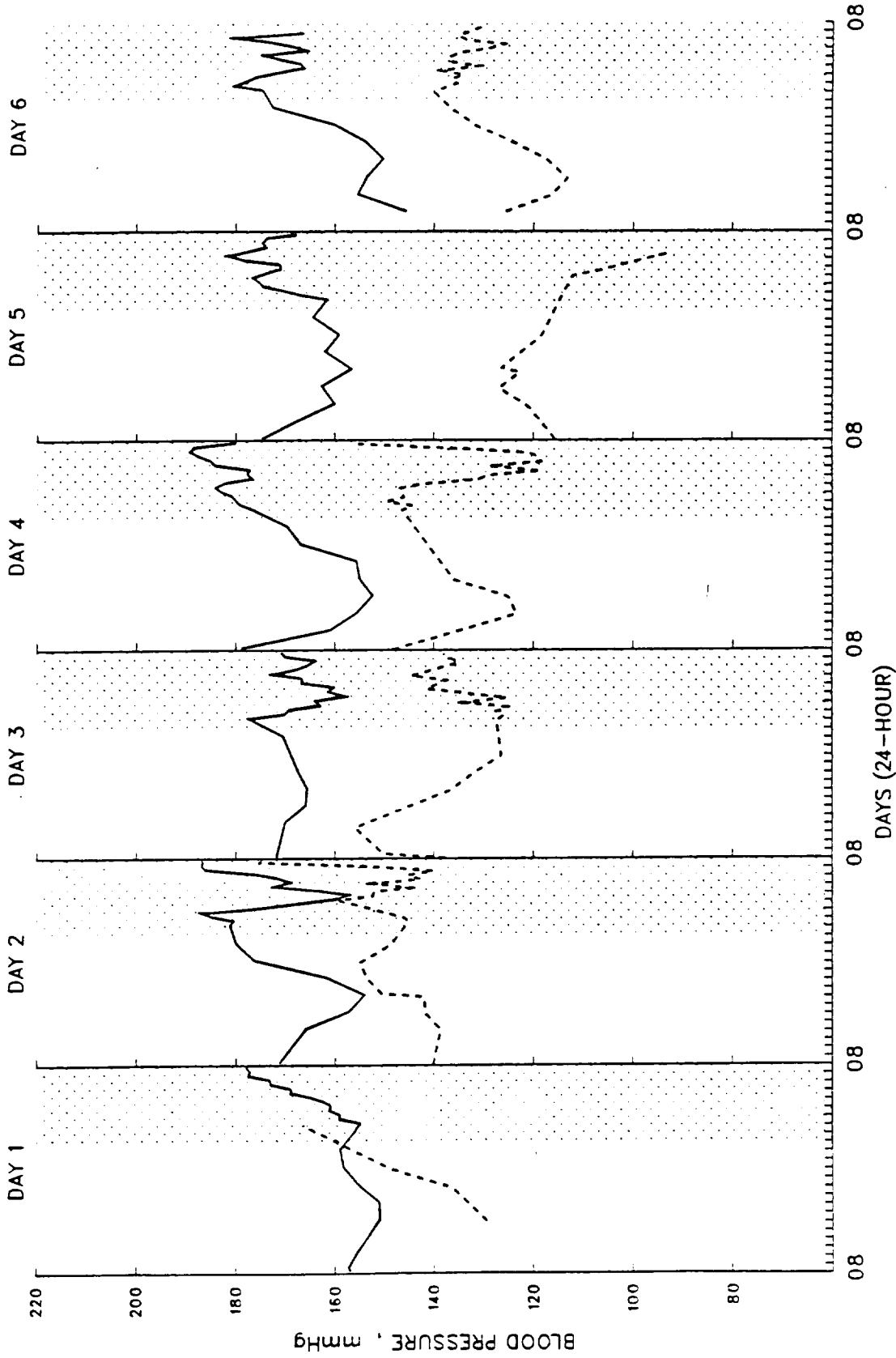

FIGURE IV-R. COSMOS 1667 CARDIOVASCULAR EXPERIMENT  
POSTFLIGHT CONTROLS (GORDYY, KVAK)  
SYSTOLIC CAROTID PRESSURE

GORDYY  
KVAK  
LIGHT OFF

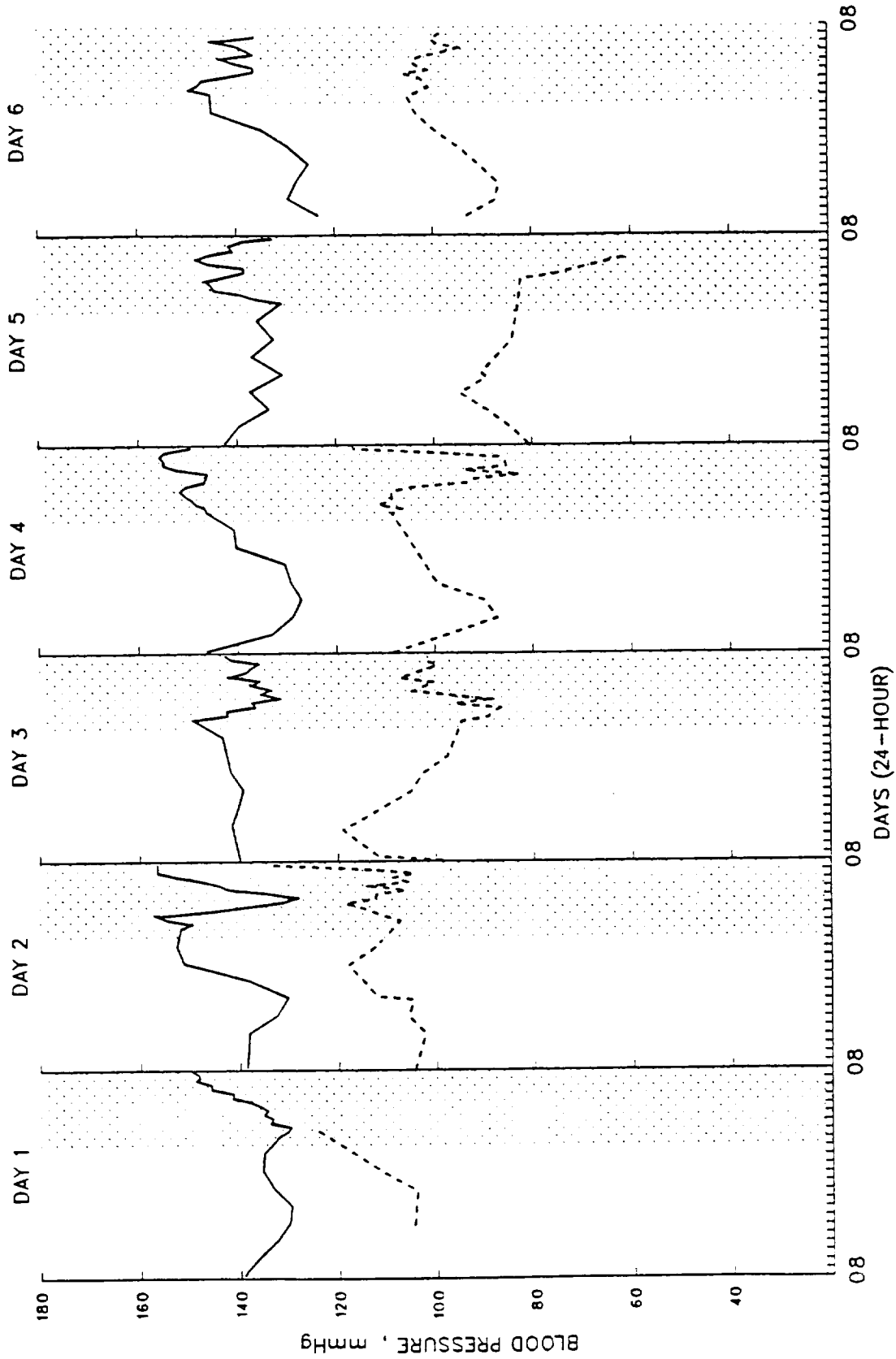

FIGURE IV-S. COSMOS 1667 CARDIOVASCULAR EXPERIMENT  
POSTFLIGHT CONTROLS (GORDYY, KVAK)  
DIASTOLIC CAROTID PRESSURE



GORDYY  
 KVAK  
 LIGHT OFF

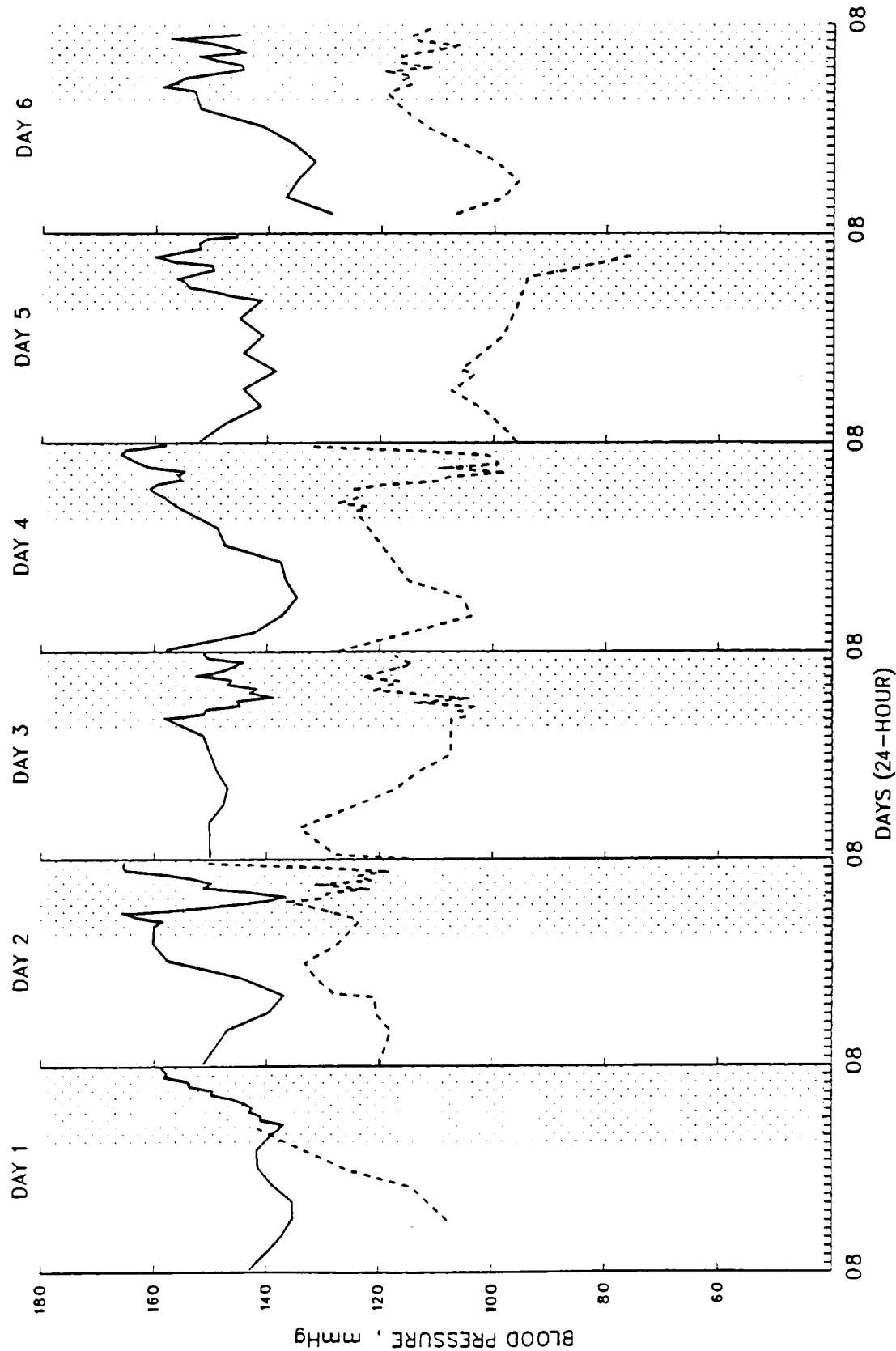

FIGURE IV-T. COSMOS 1667 CARDIOVASCULAR EXPERIMENT  
 POSTFLIGHT CONTROLS (GORDYY, KVAK)  
 MEAN CAROTID PRESSURE

GORDYY  
KVAK  
LIGHT OFF

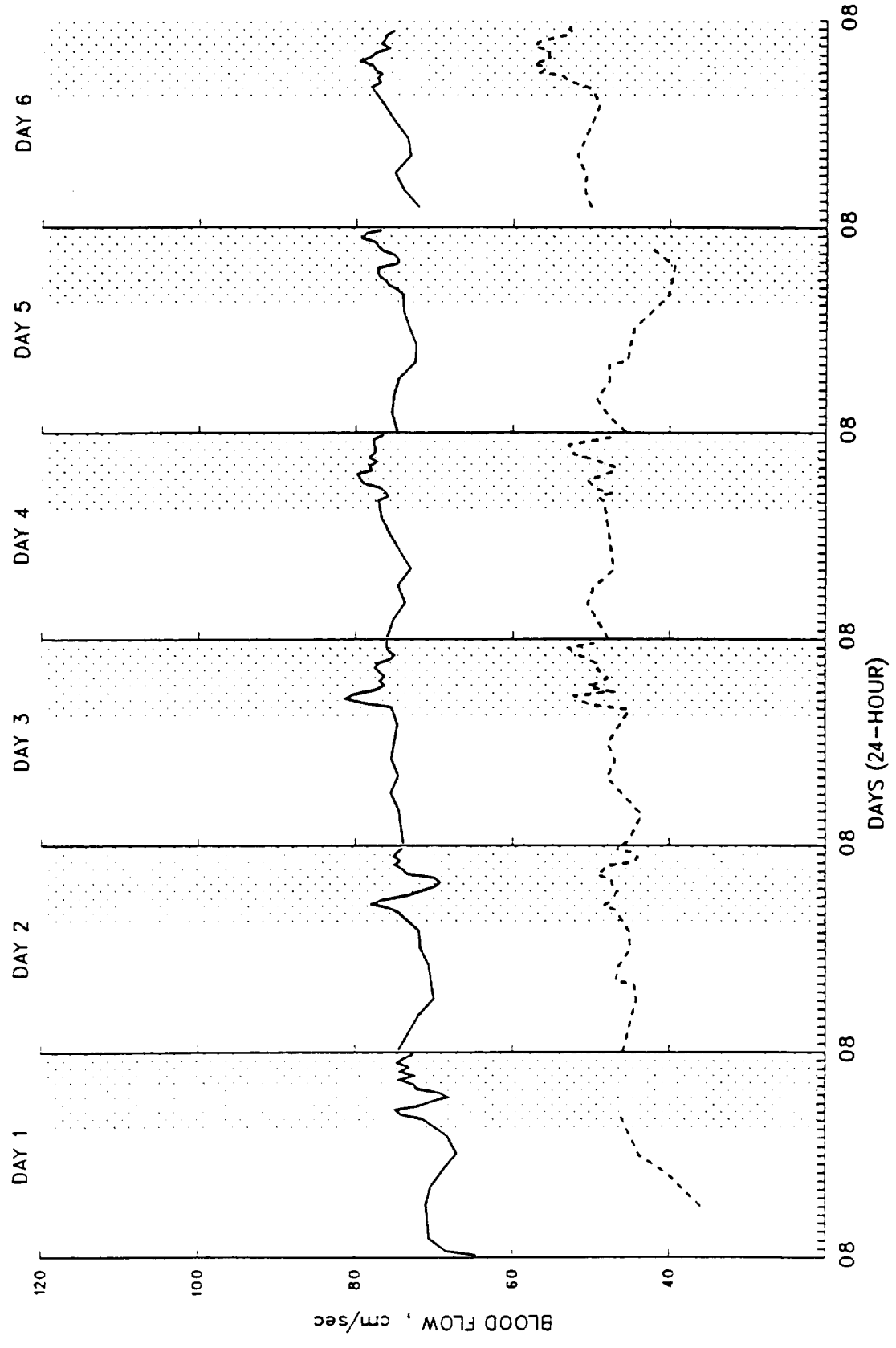

FIGURE IV-U. COSMOS 1667 CARDIOVASCULAR EXPERIMENT  
POSTFLIGHT CONTROLS (GORDYY, KVAK)  
MAX CAROTID FLOW

GORDYY  
KVAK  
LIGHT OFF

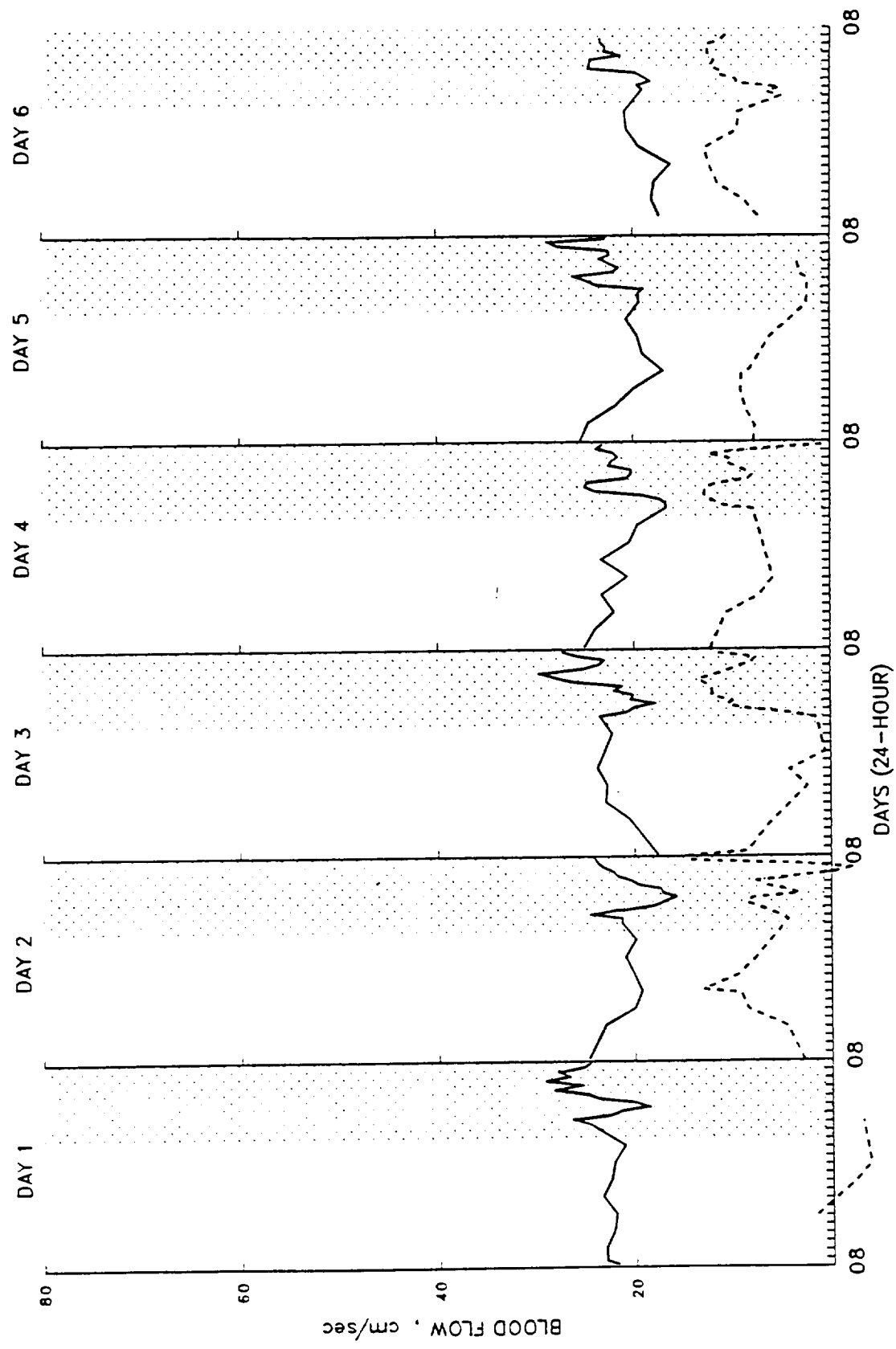

FIGURE IV-V. COSMOS 1667 CARDIOVASCULAR EXPERIMENT  
POSTFLIGHT CONTROLS (GORDYY, KVAK)  
MIN CAROTID FLOW

C-2

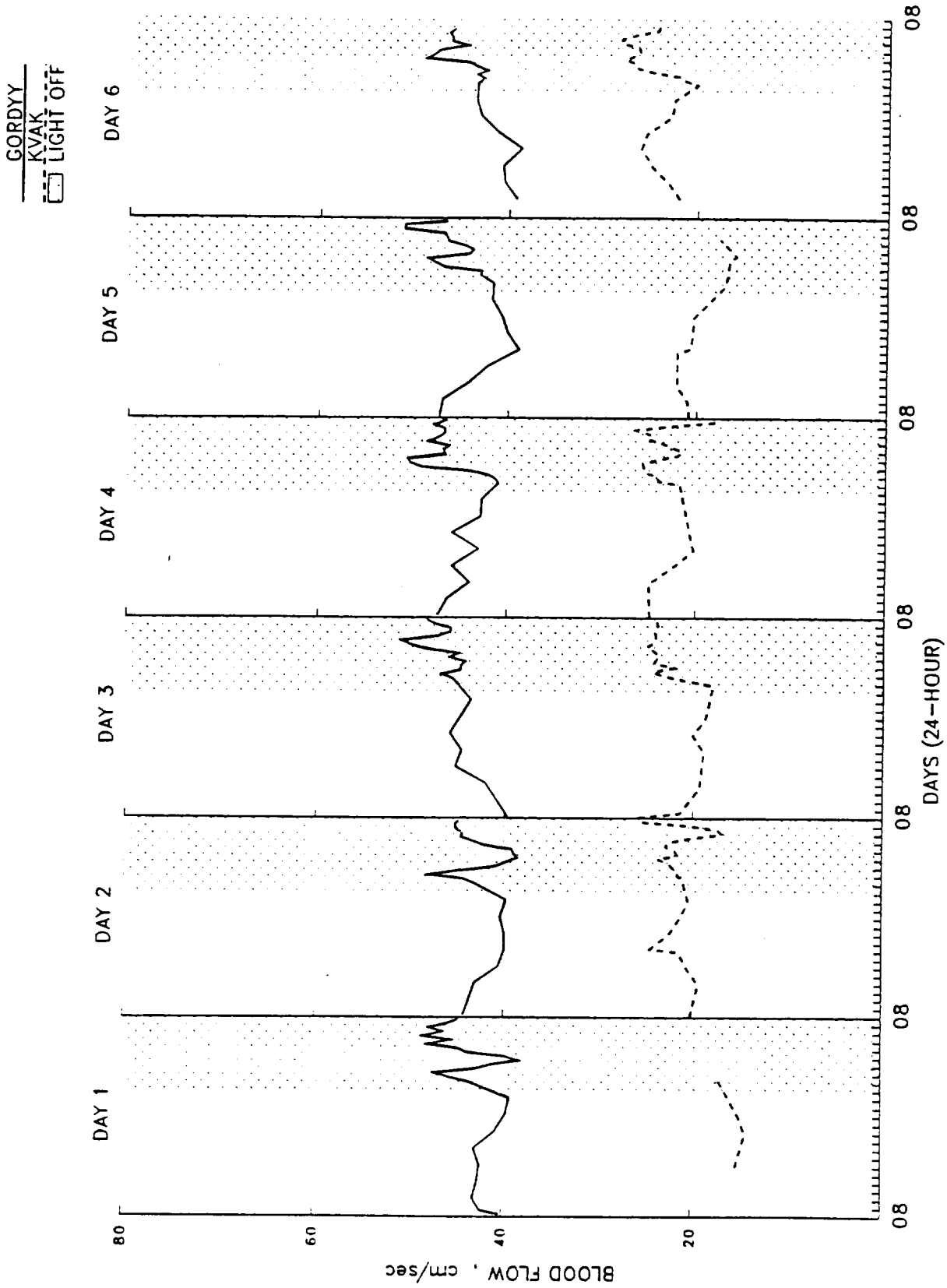

FIGURE IV-W. COSMOS 1667 CARDIOVASCULAR EXPERIMENT  
 POSTFLIGHT CONTROLS (GORDYY, KVAK)  
 MEAN CAROTID FLOW

GORDYY  
 KVAK  
 LIGHT OFF

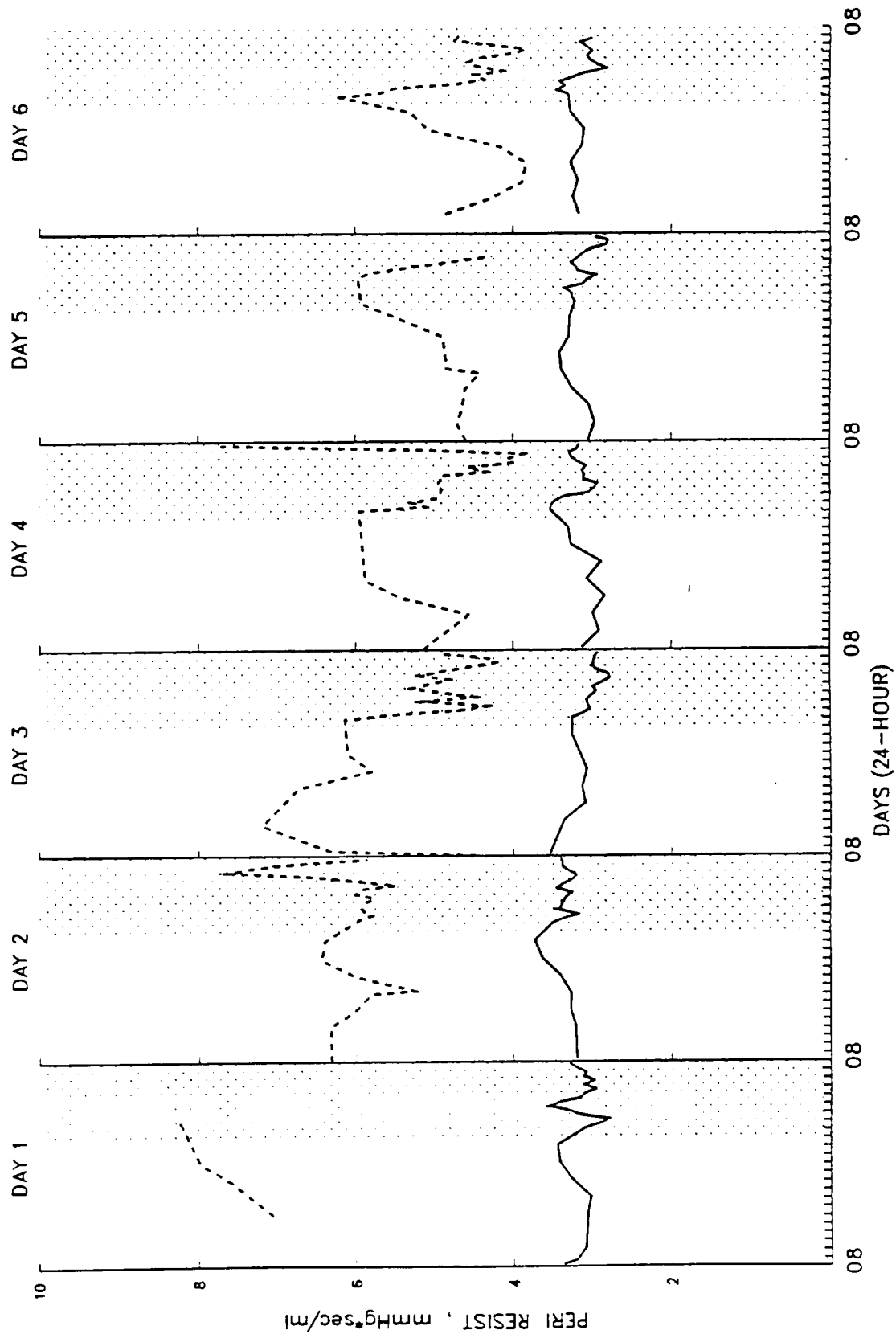

FIGURE IV-X. COSMOS 1667 CARDIOVASCULAR EXPERIMENT  
 POSTFLIGHT CONTROLS (GORDYY, KVAK)  
 PERIPHERAL RESISTANCE

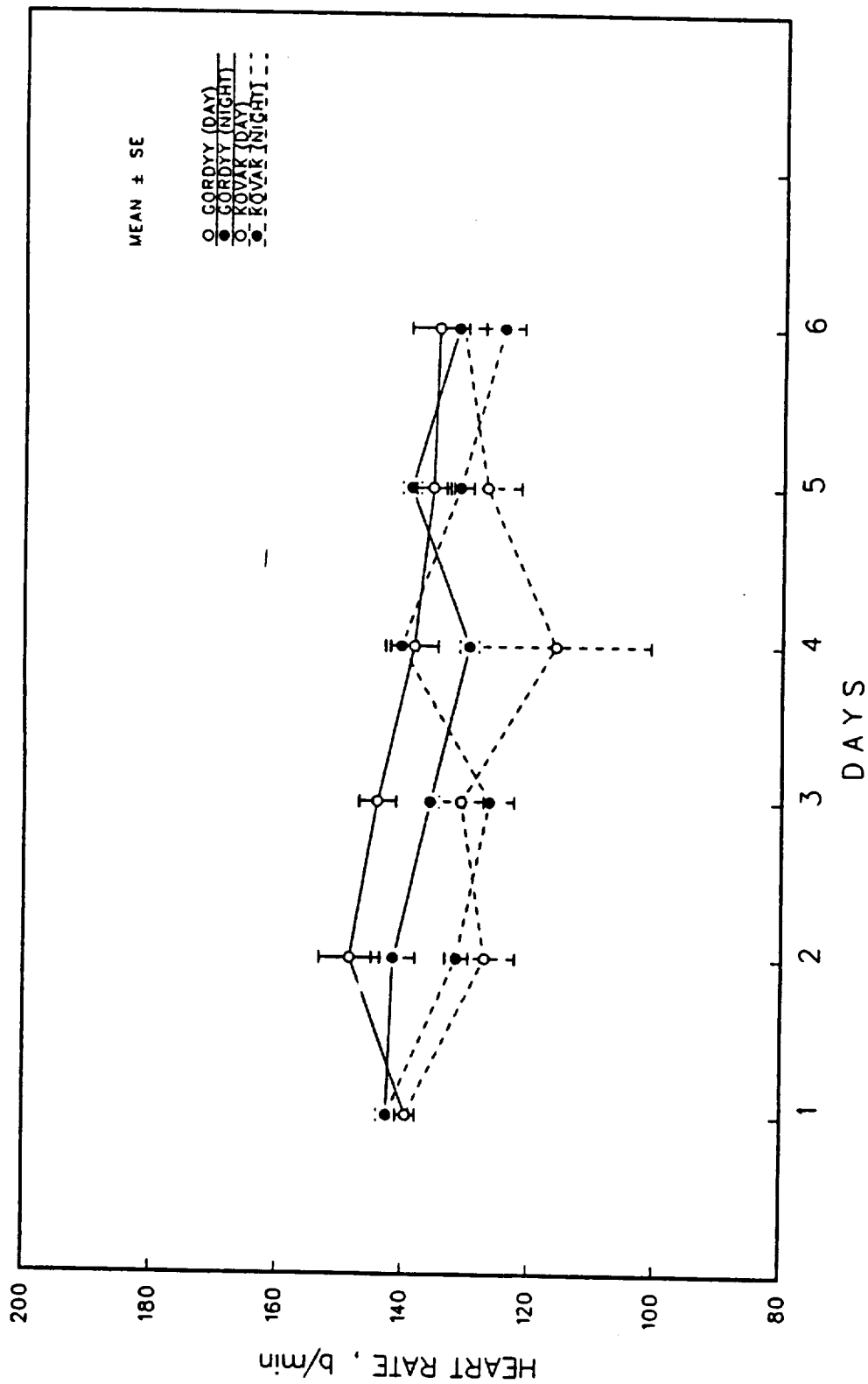

FIGURE IV-Y. COSMOS 1667 CARDIOVASCULAR EXPERIMENT  
 POSTFLIGHT CONTROLS (GORDYY, KOVAK)  
 HEART RATE

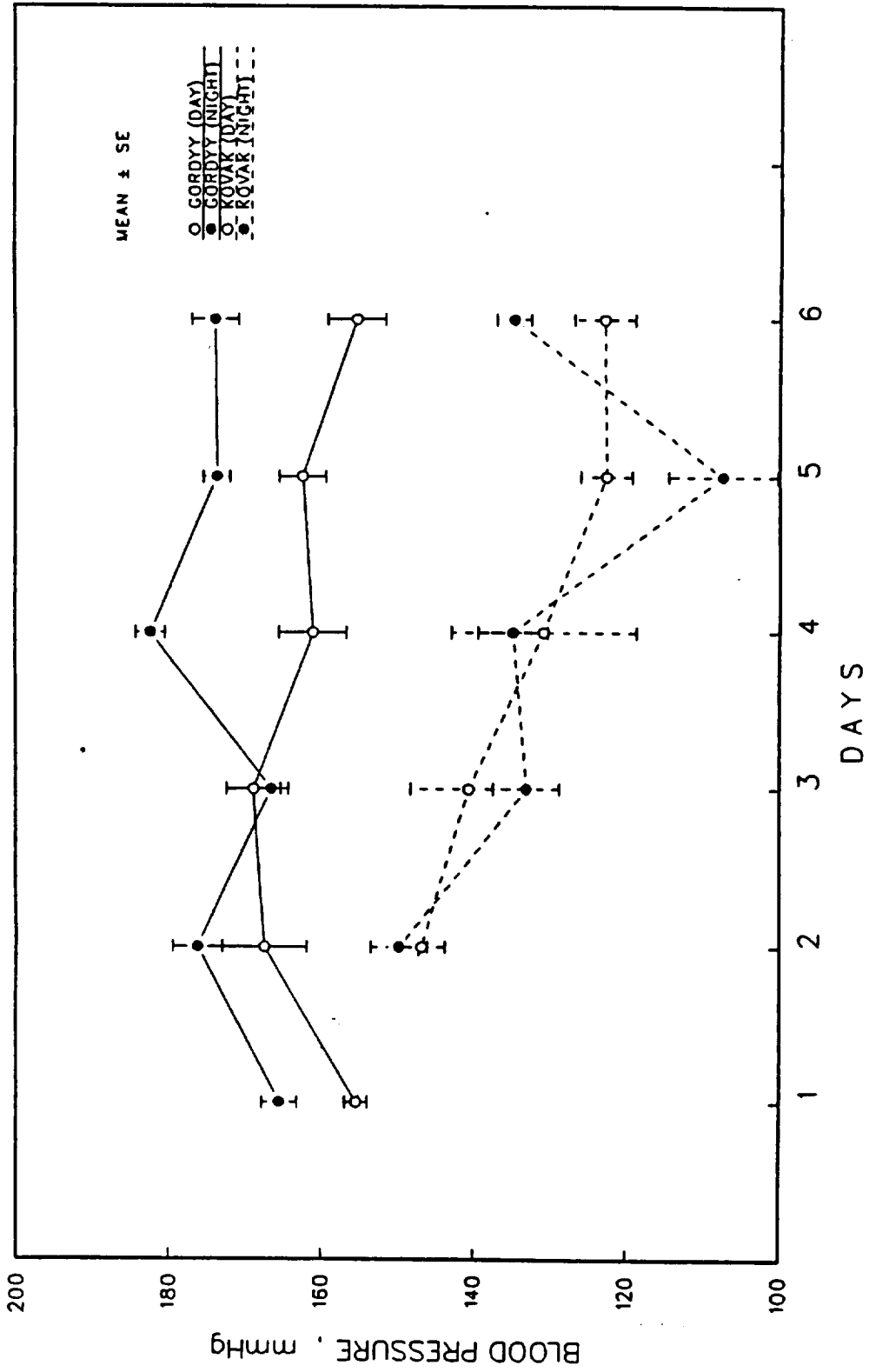

FIGURE IV-Z. COSMOS 1667 CARDIOVASCULAR EXPERIMENT  
 POSTFLIGHT CONTROLS (GORDYY, KOVAK)  
 SYSTOLIC CAROTID PRESSURE

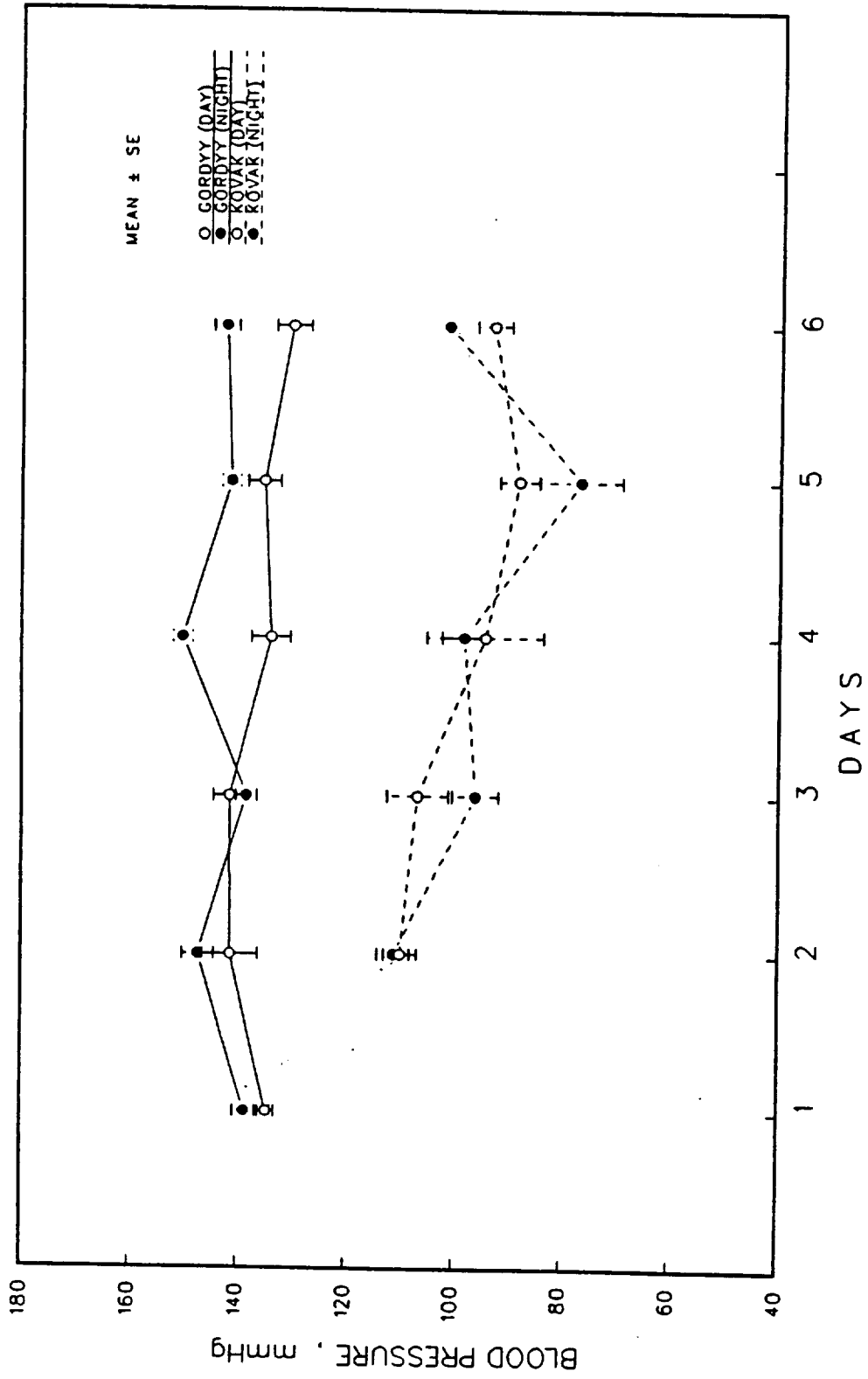

FIGURE IV-AA. COSMOS 1667 CARDIOVASCULAR EXPERIMENT  
 POSTFLIGHT CONTROLS (GORDYY, KOVAK)  
 DIASTOLIC CAROTID PRESSURE



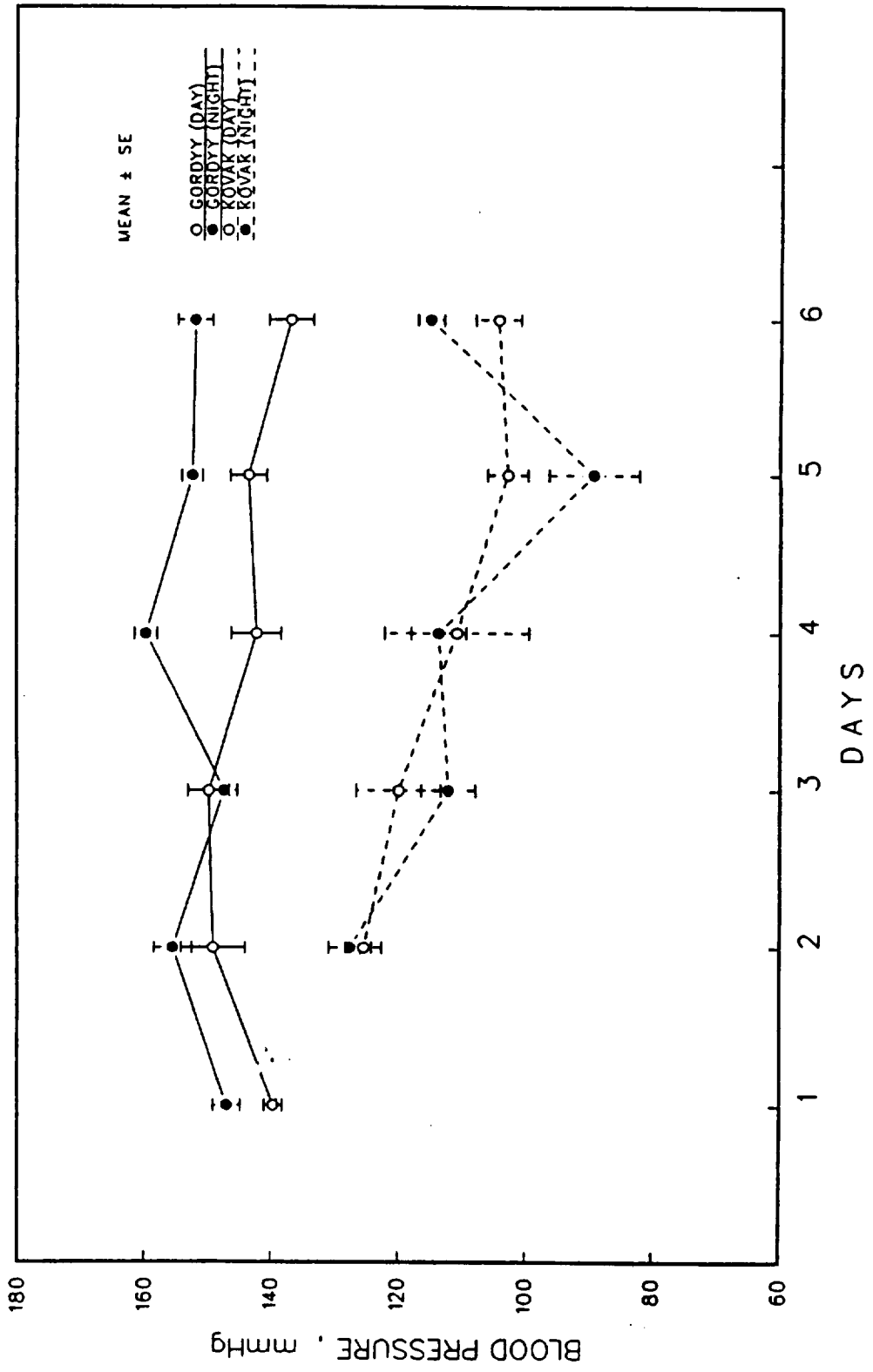

FIGURE IV-AB. COSMOS 1667 CARDIOVASCULAR EXPERIMENT  
 POSTFLIGHT CONTROLS (GORDYY, KOVAK)  
 MEAN CAROTID PRESSURE

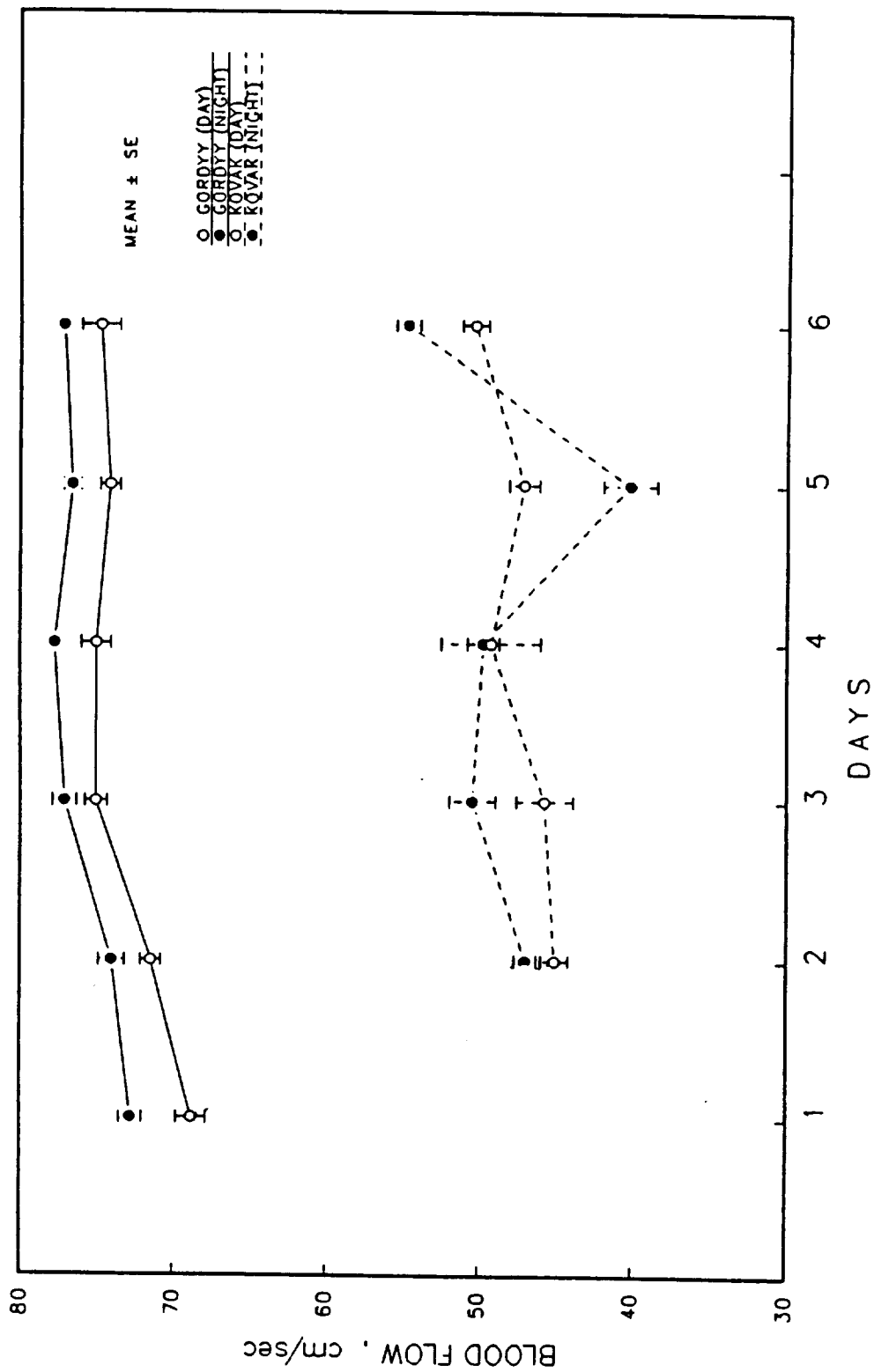

FIGURE IV-AC. COSMOS 1667 CARDIOVASCULAR EXPERIMENT  
 POSTFLIGHT CONTROLS (GORDYY, KOVAR)  
MAX CAROTID FLOW

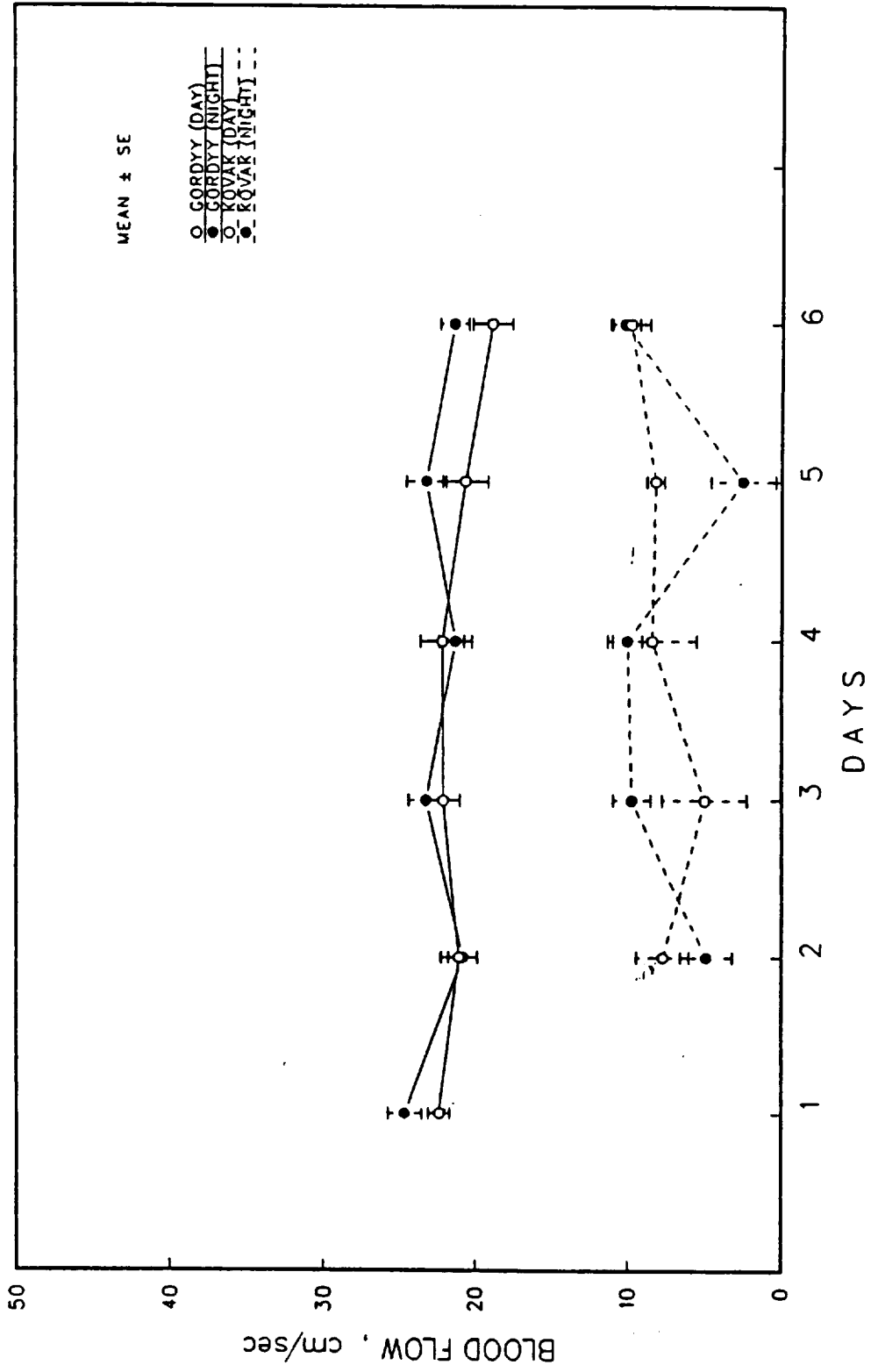

FIGURE IV-AD. COSMOS 1667 CARDIOVASCULAR EXPERIMENT  
 POSTFLIGHT CONTROLS (GORDYY, KOVAK)  
MIN CAROTID FLOW

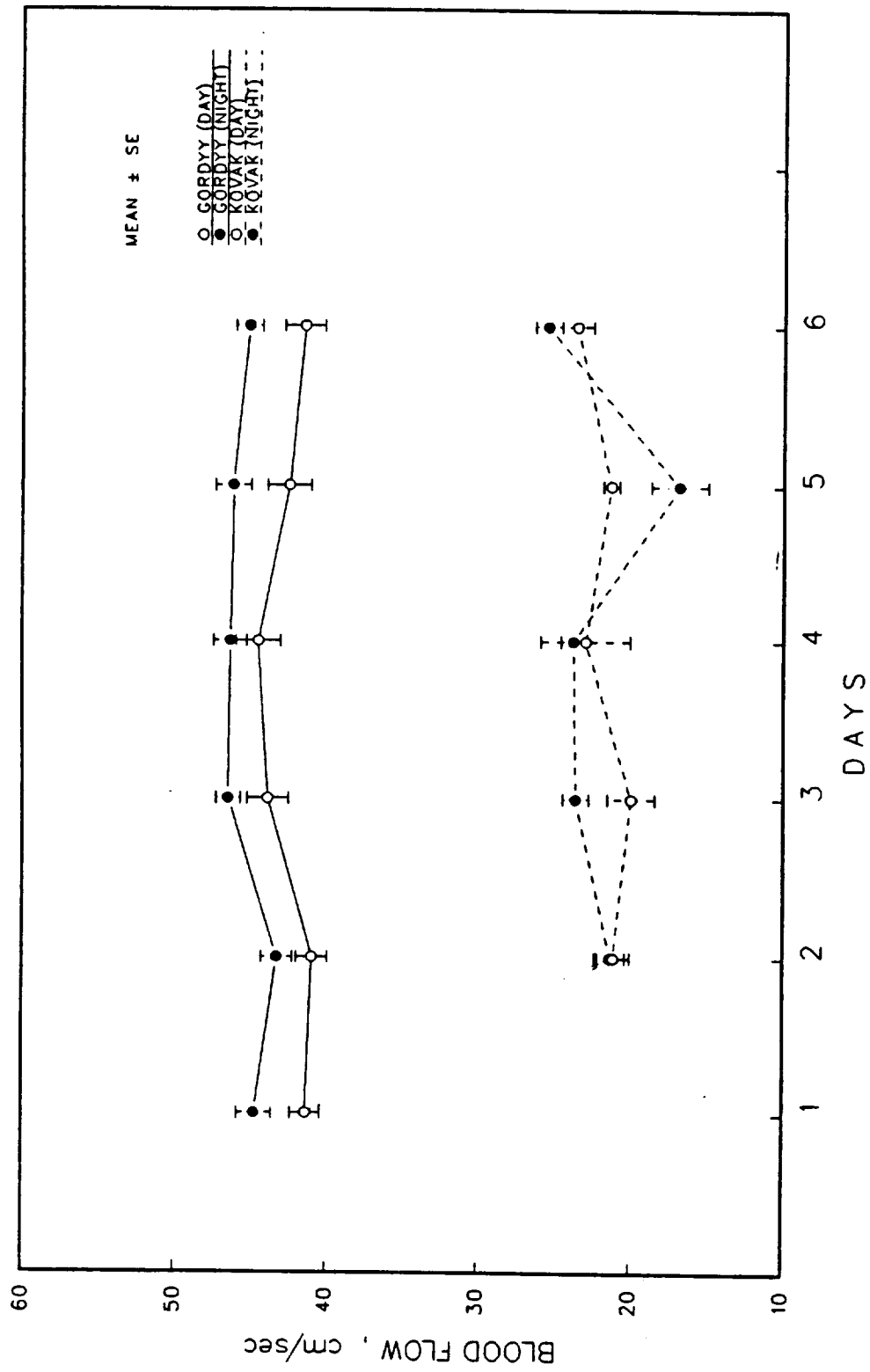

FIGURE IV-AE. COSMOS 1667 CARDIOVASCULAR EXPERIMENT  
 POSTFLIGHT CONTROLS (GORDYY, KOVAK)  
 MEAN CAROTID FLOW

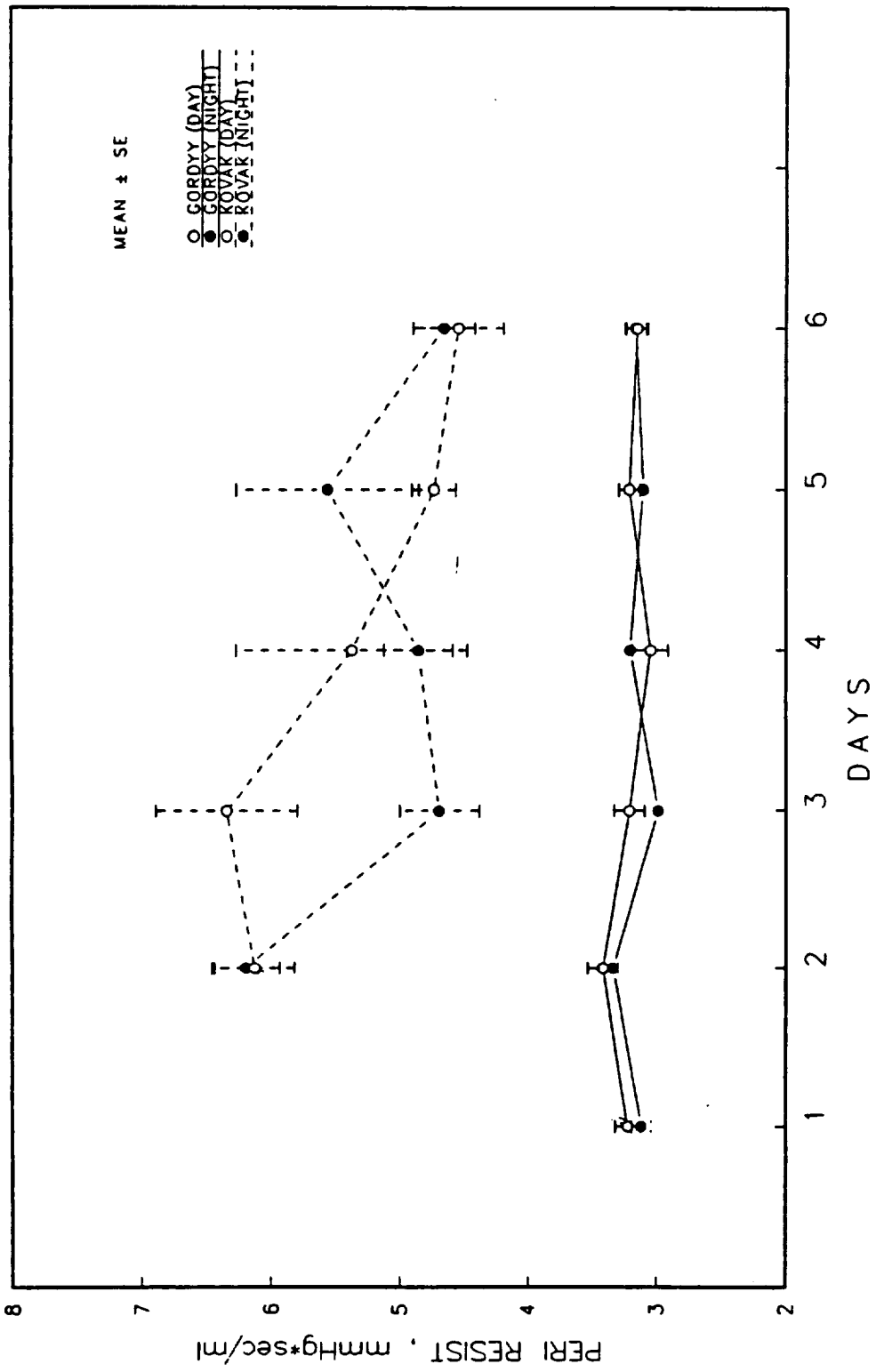

FIGURE IV-AF. COSMOS 1667 CARDIOVASCULAR EXPERIMENT  
 POSTFLIGHT CONTROLS (GORDYY, KOVAK)  
 PERIPHERAL RESISTANCE

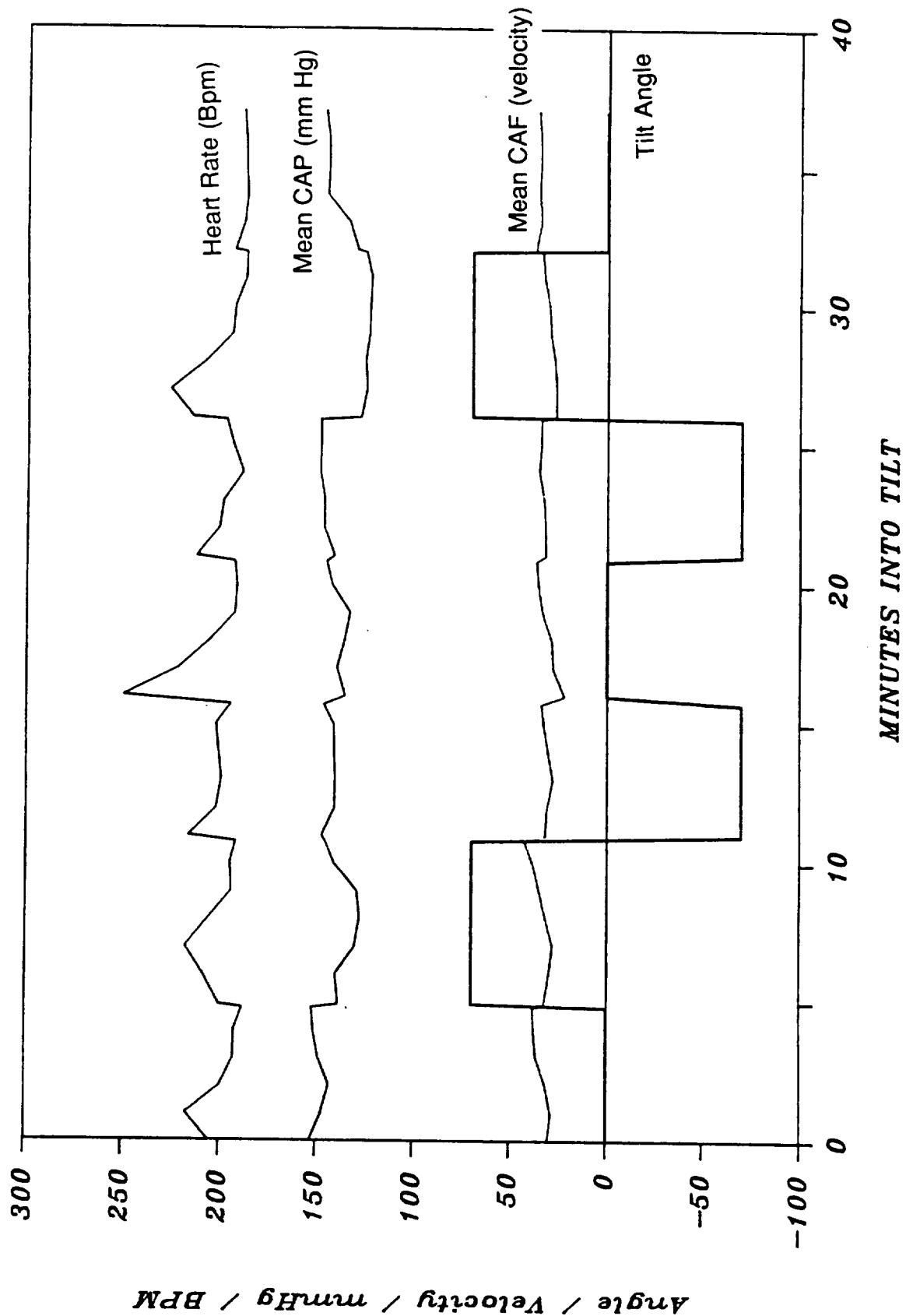

FIGURE V-A. KVAK TILT DATA  
PRE-FLIGHT: 24 JUNE 1985

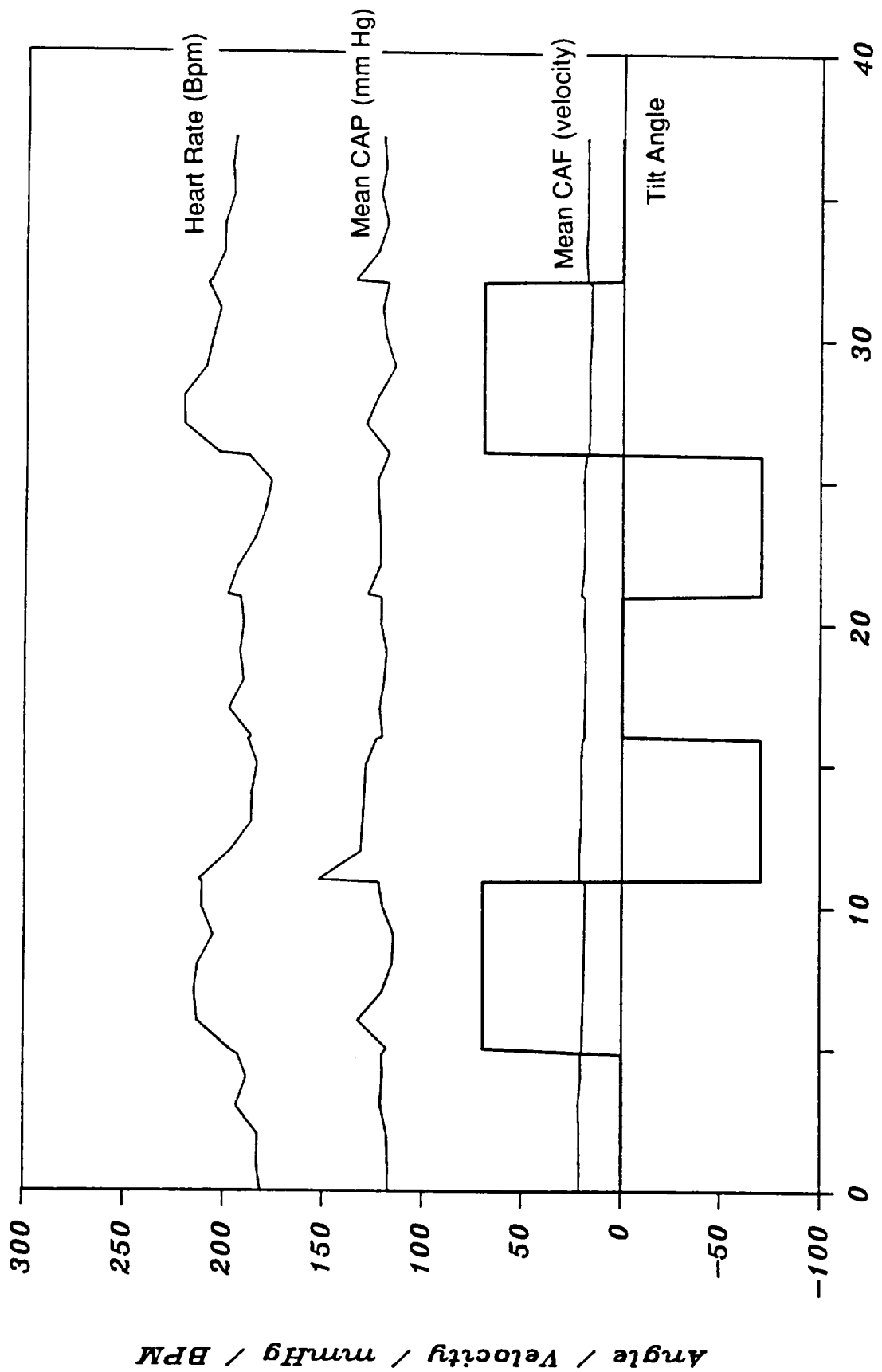

FIGURE V-B. KVAK TILT DATA  
 SYNCHRONOUS CONTROL: 23 AUGUST 1985

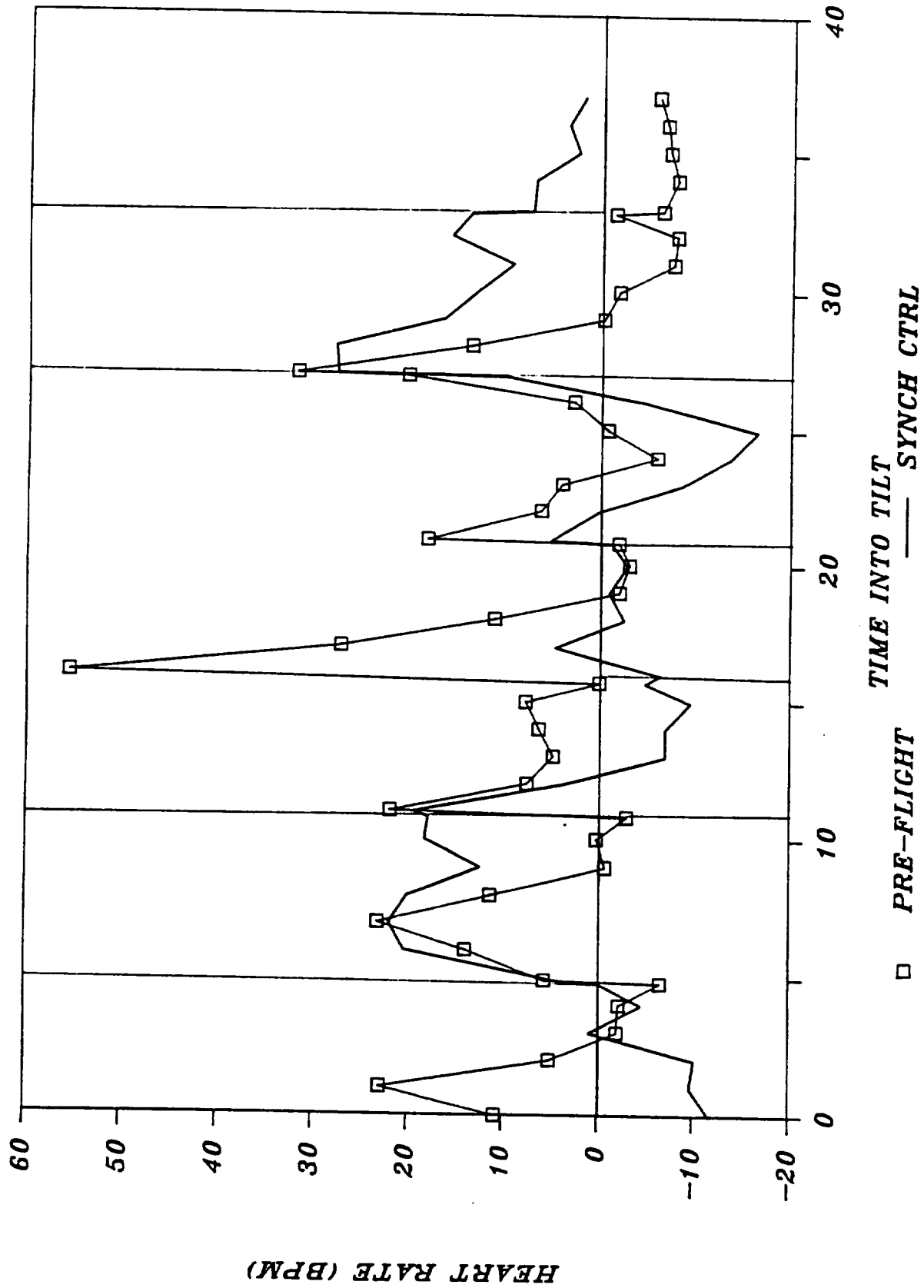

FIGURE V-C. KVAK TILT DATA  
COMPARISON OF DELTA HR FROM CONTROL



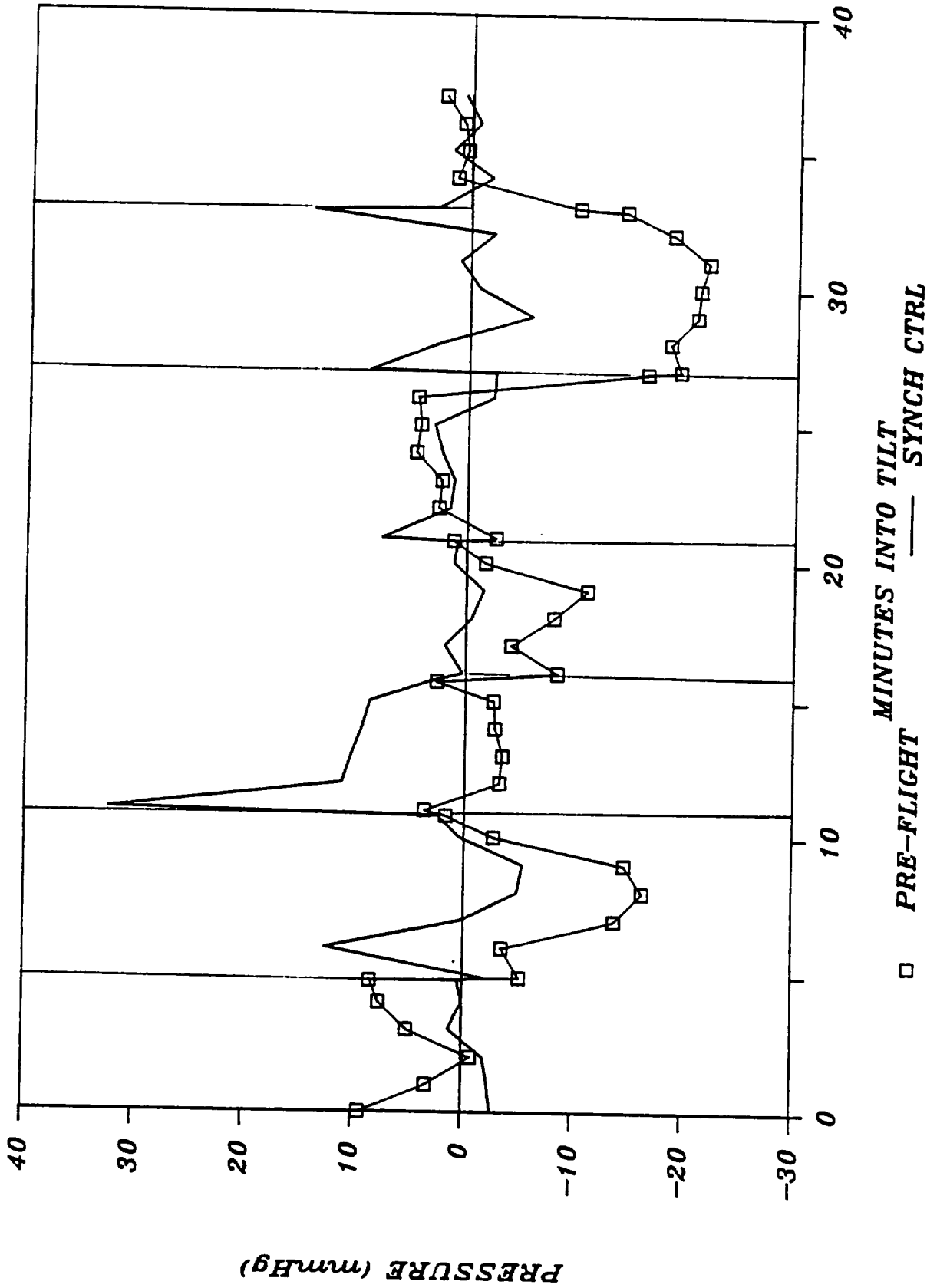

FIGURE V-D. KVAK TILT DATA  
 COMPARISON OF DELTA CAP FROM CONTROL

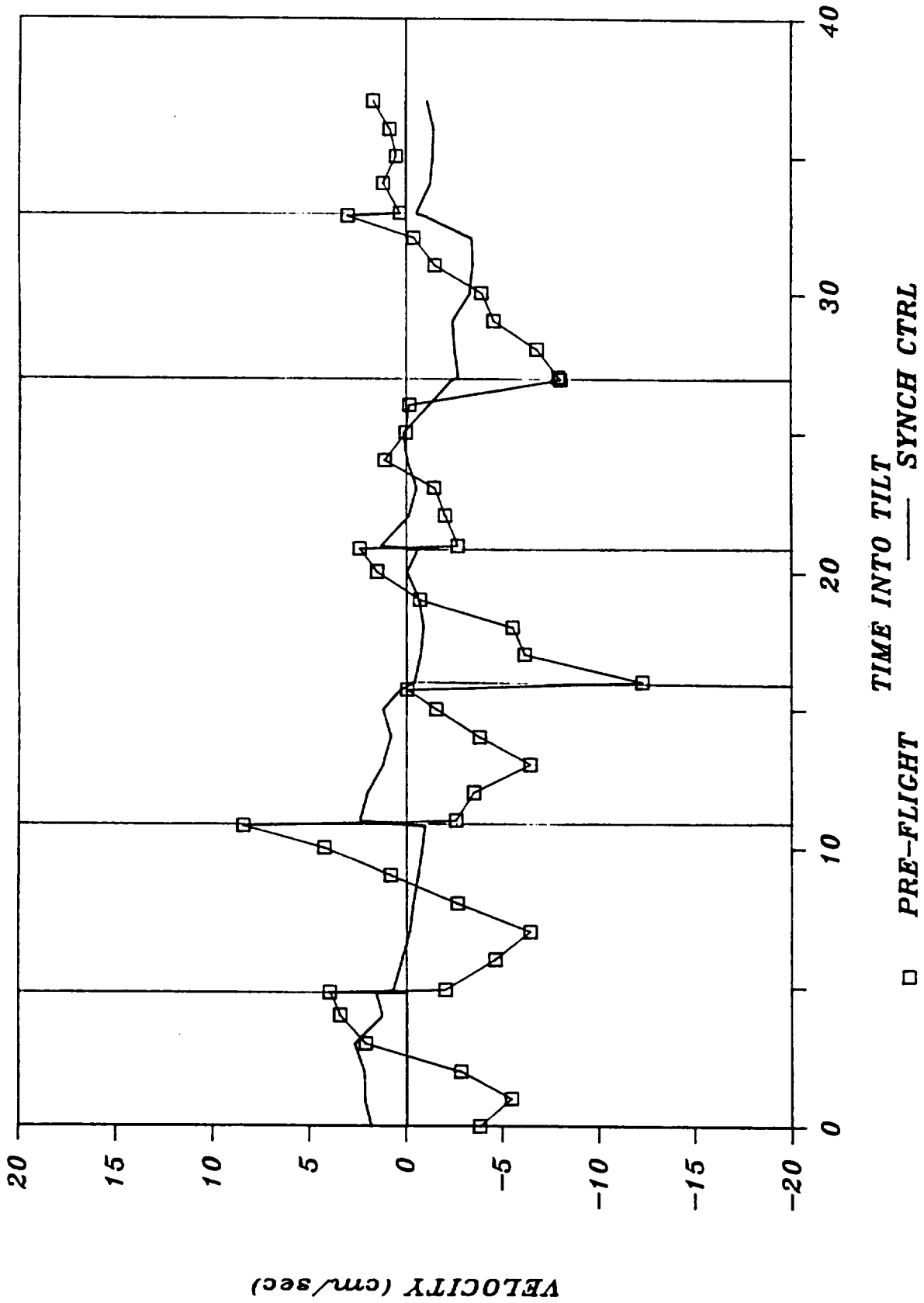
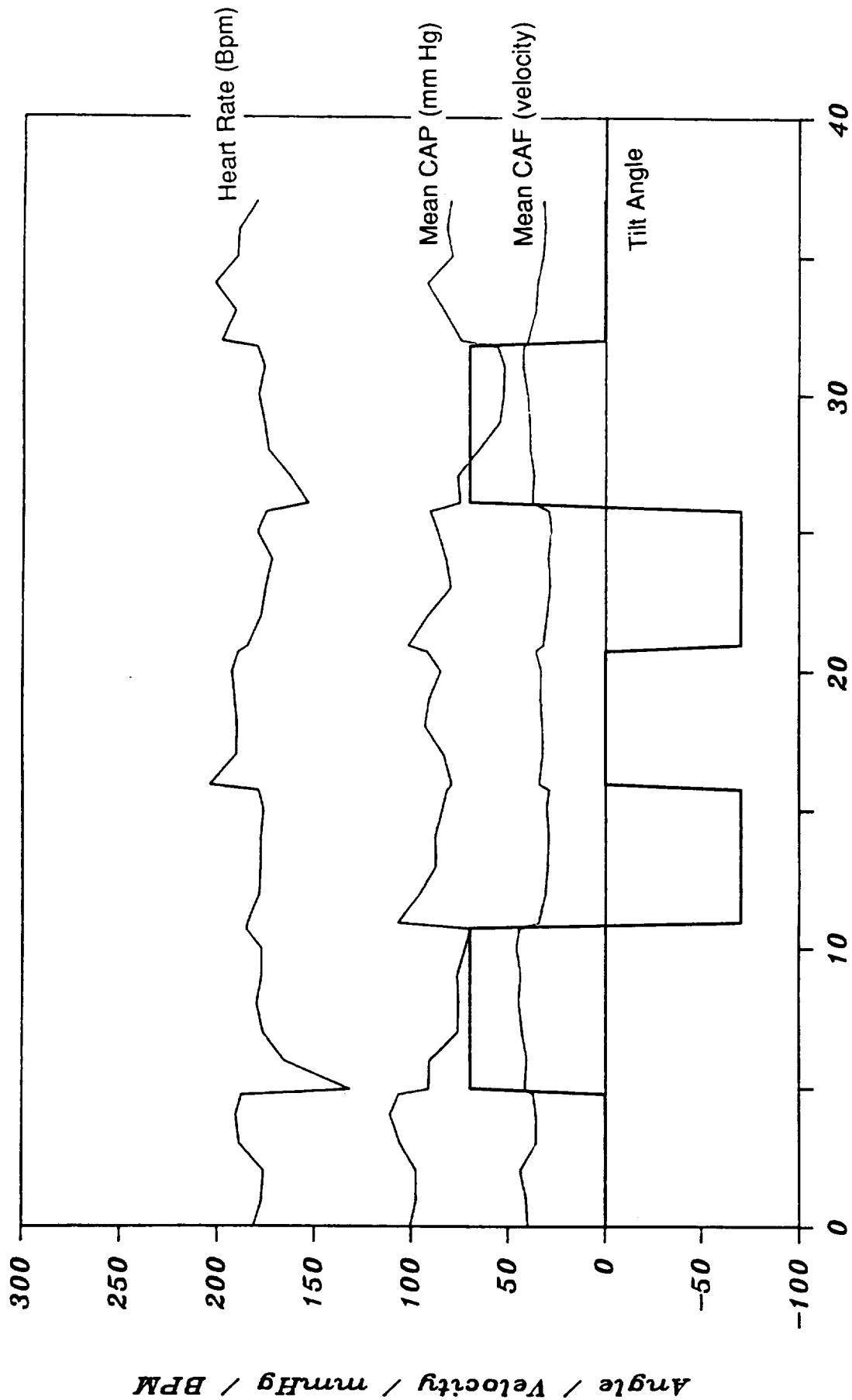
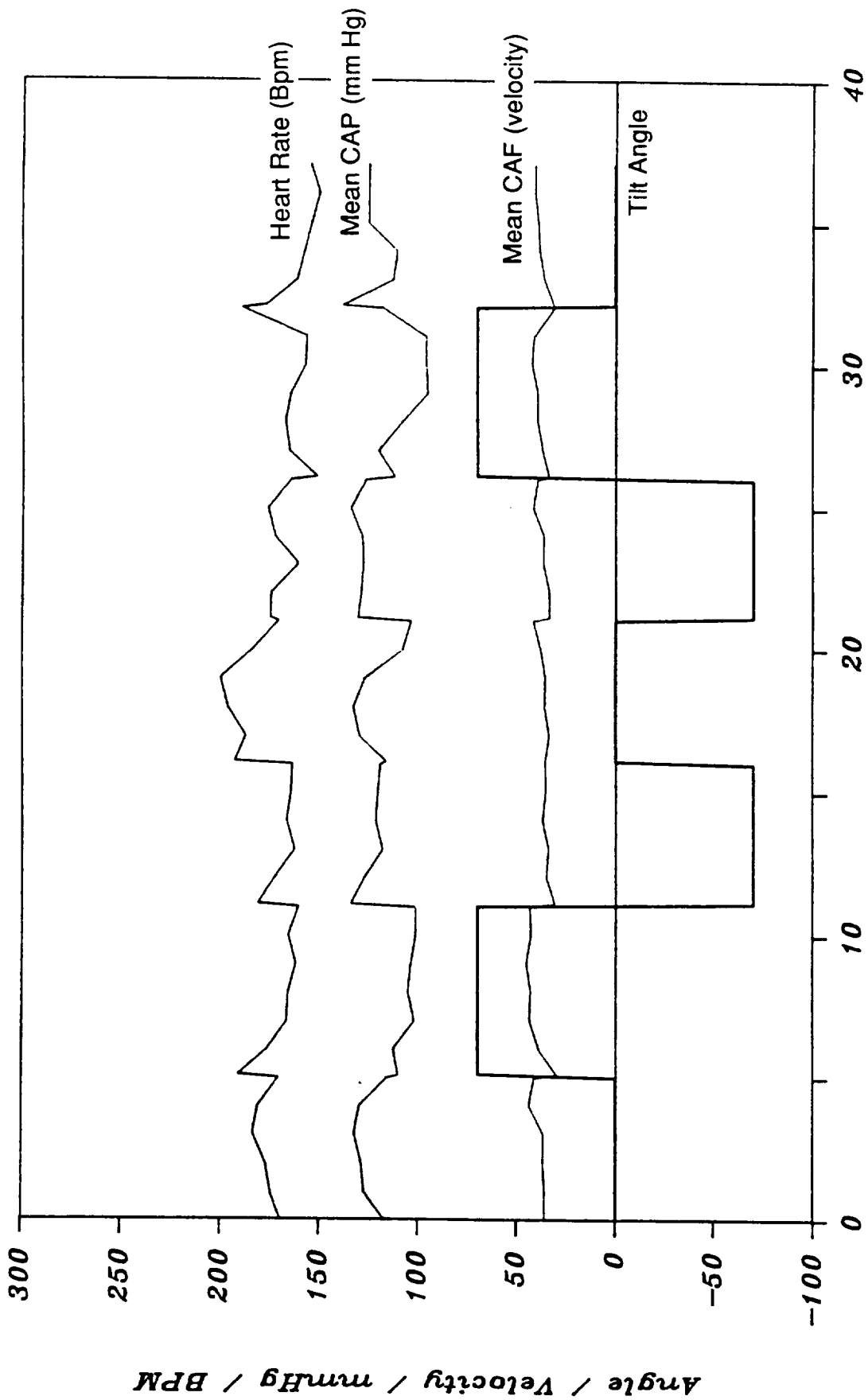

FIGURE V-E. KVAK TILT DATA  
COMPARISON OF DELTA CAF FROM CONTROL



**MINUTES INTO TILT**

**FIGURE V-F. SAMURAI TILT DATA  
PRE-FLIGHT: 27 JUNE 1985**



*MINUTES INTO TILT*

FIGURE V-G. SAMURAI TILT DATA  
POST-FLIGHT: 12 AUGUST 1985

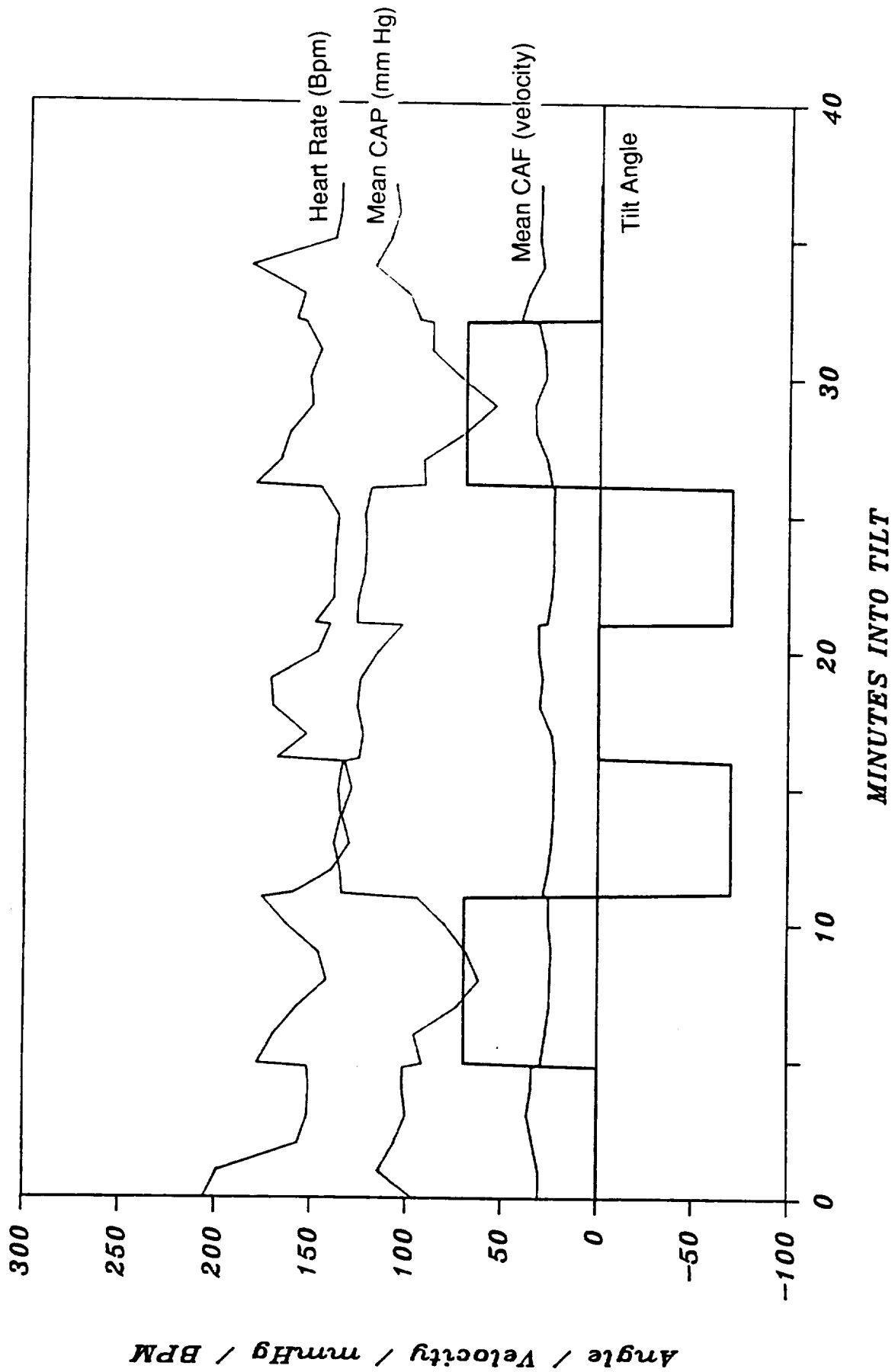

FIGURE V-H. SAMURAI TILT DATA  
 SYNCHRONOUS CONTROL: 23 AUGUST 1985

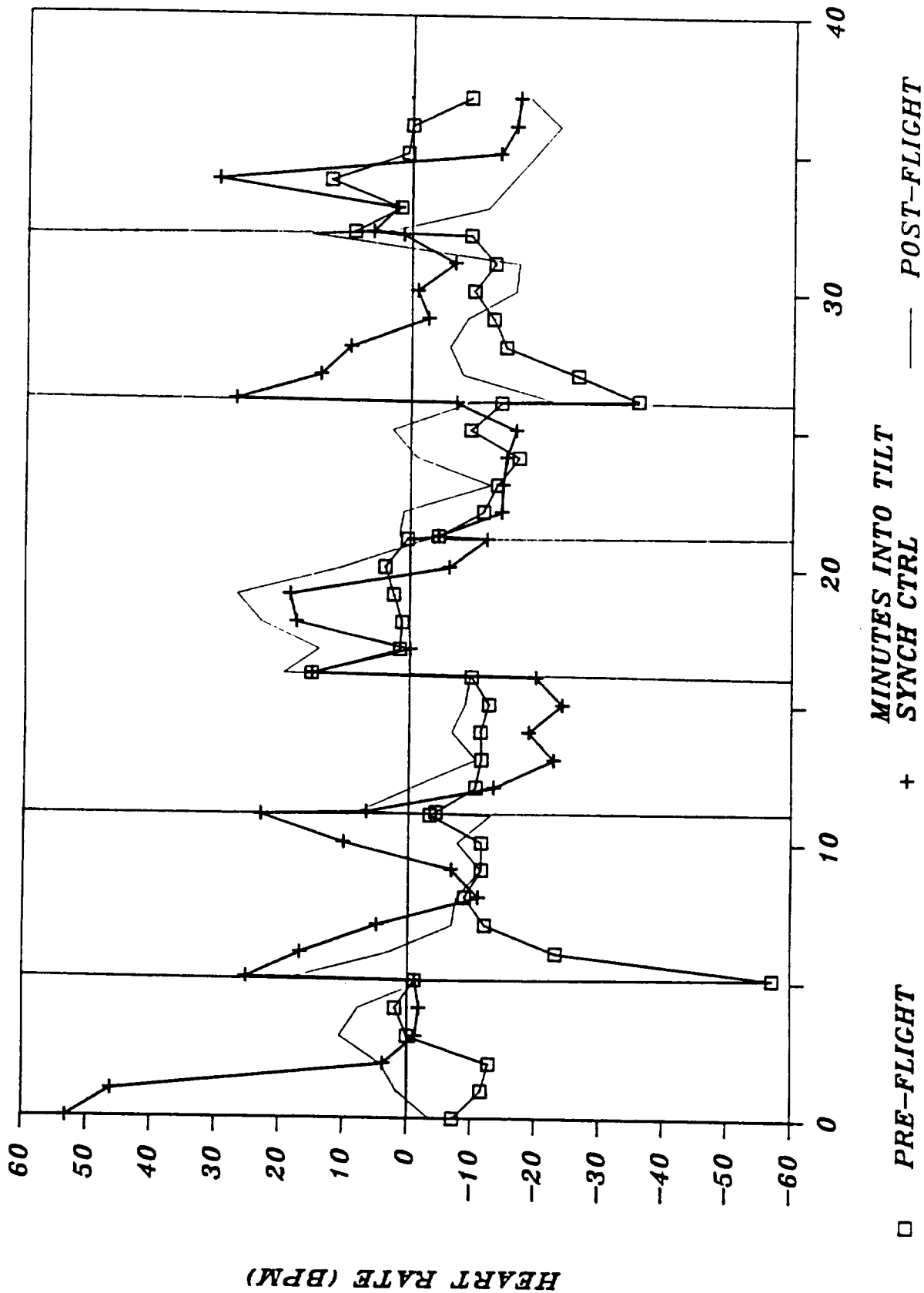

FIGURE V-1. SAMURAI TILT DATA  
COMPARISON OF DELTA HR FROM CONTROL

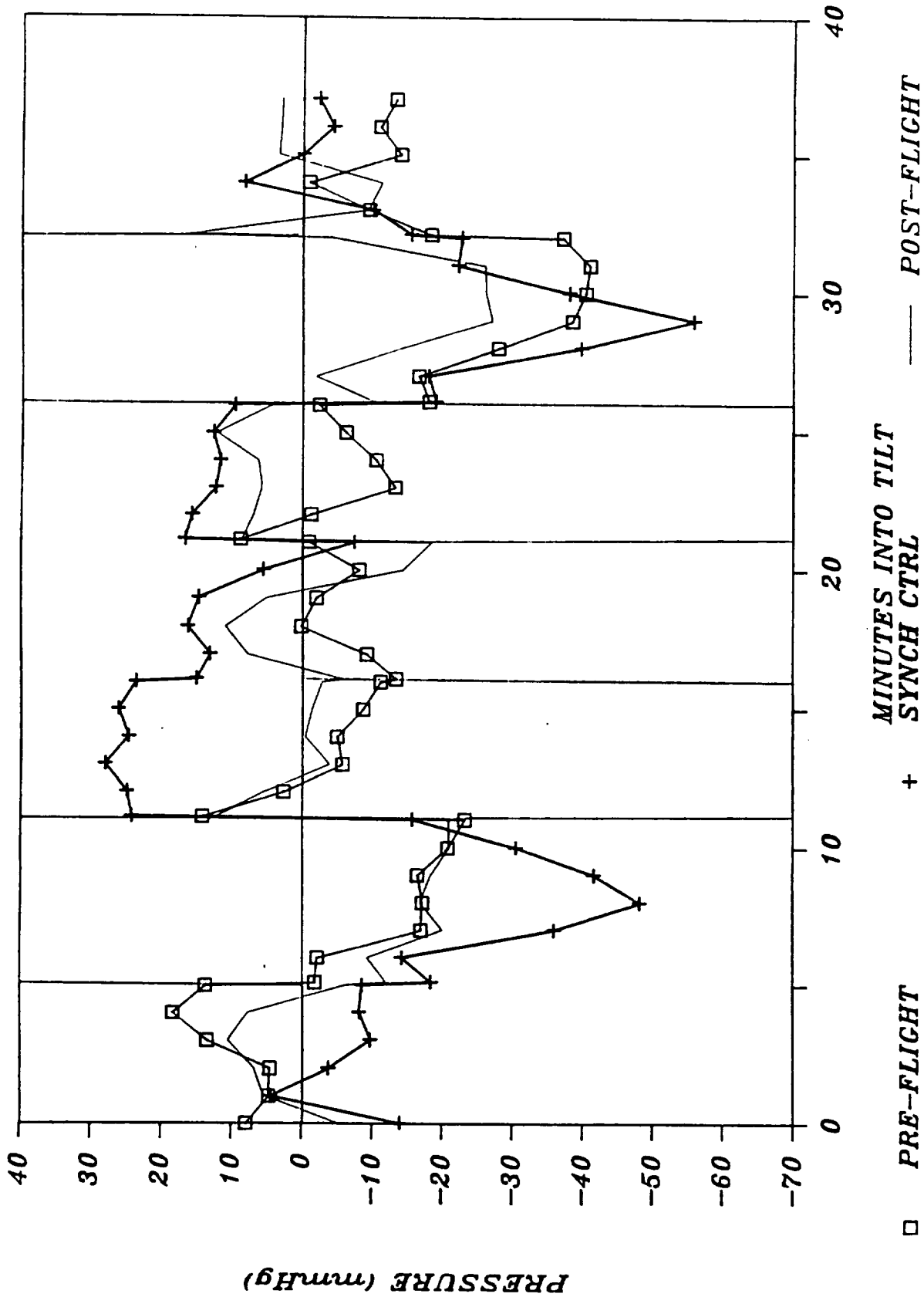

FIGURE V-J. SAMURAI TILT DATA  
COMPARISON OF DELTA CAP FROM CONTROL

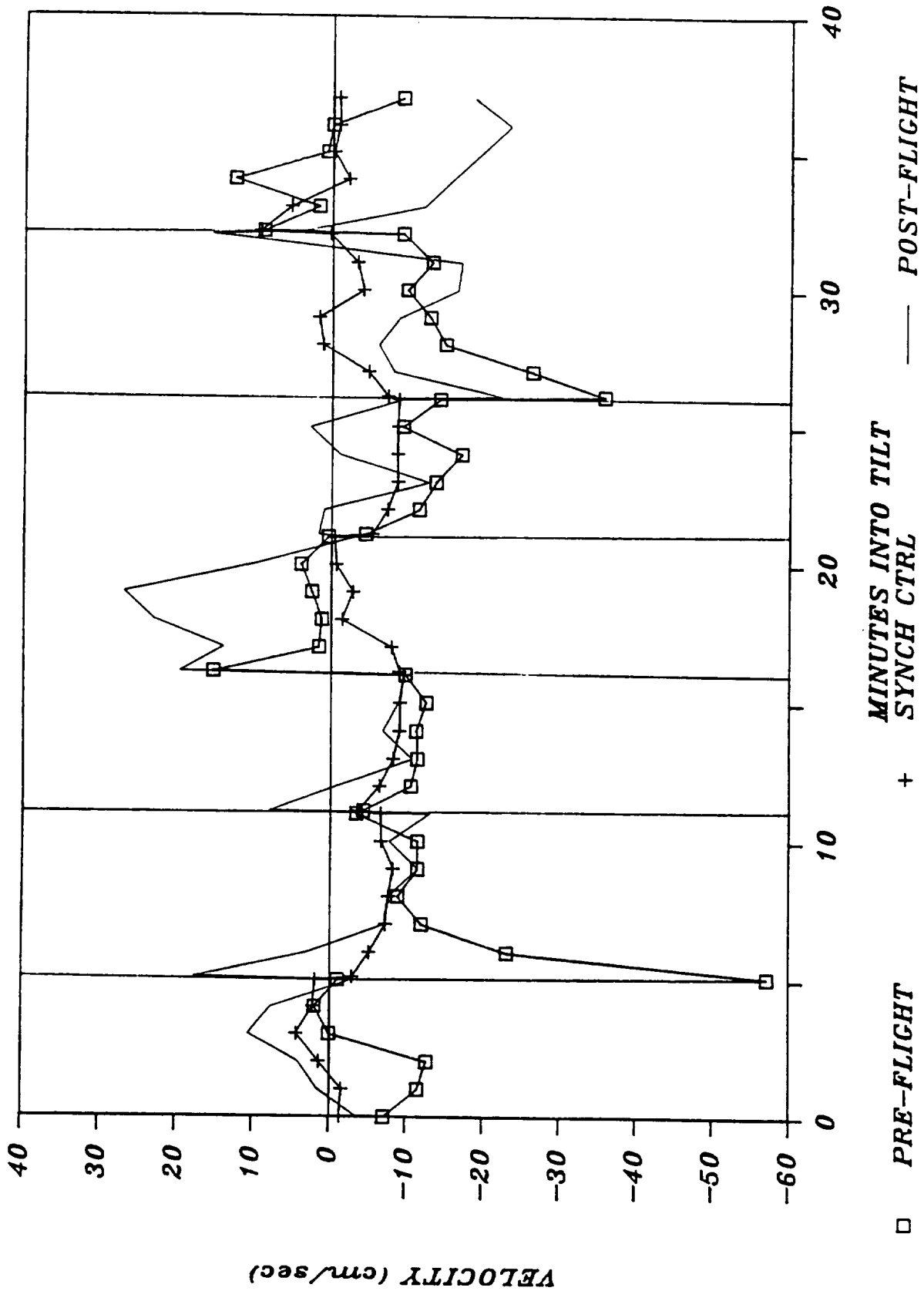
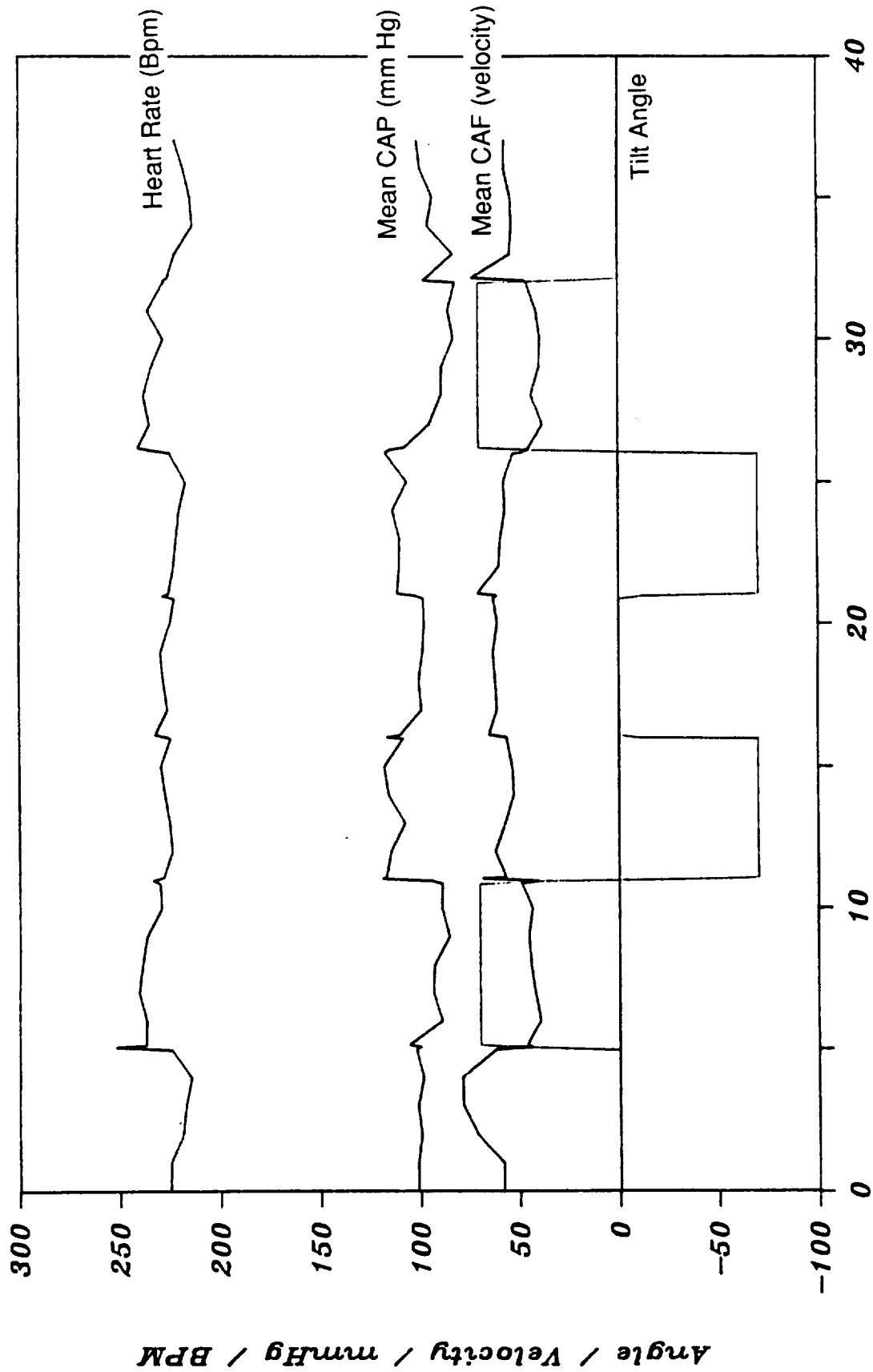

FIGURE V-K. SAMURAI TILT DATA  
COMPARISON OF DELTA CAF FROM CONTROL





*Minutes Into TILT*

FIGURE V-L. GORDYY TILT DATA  
PRE-FLIGHT TILT

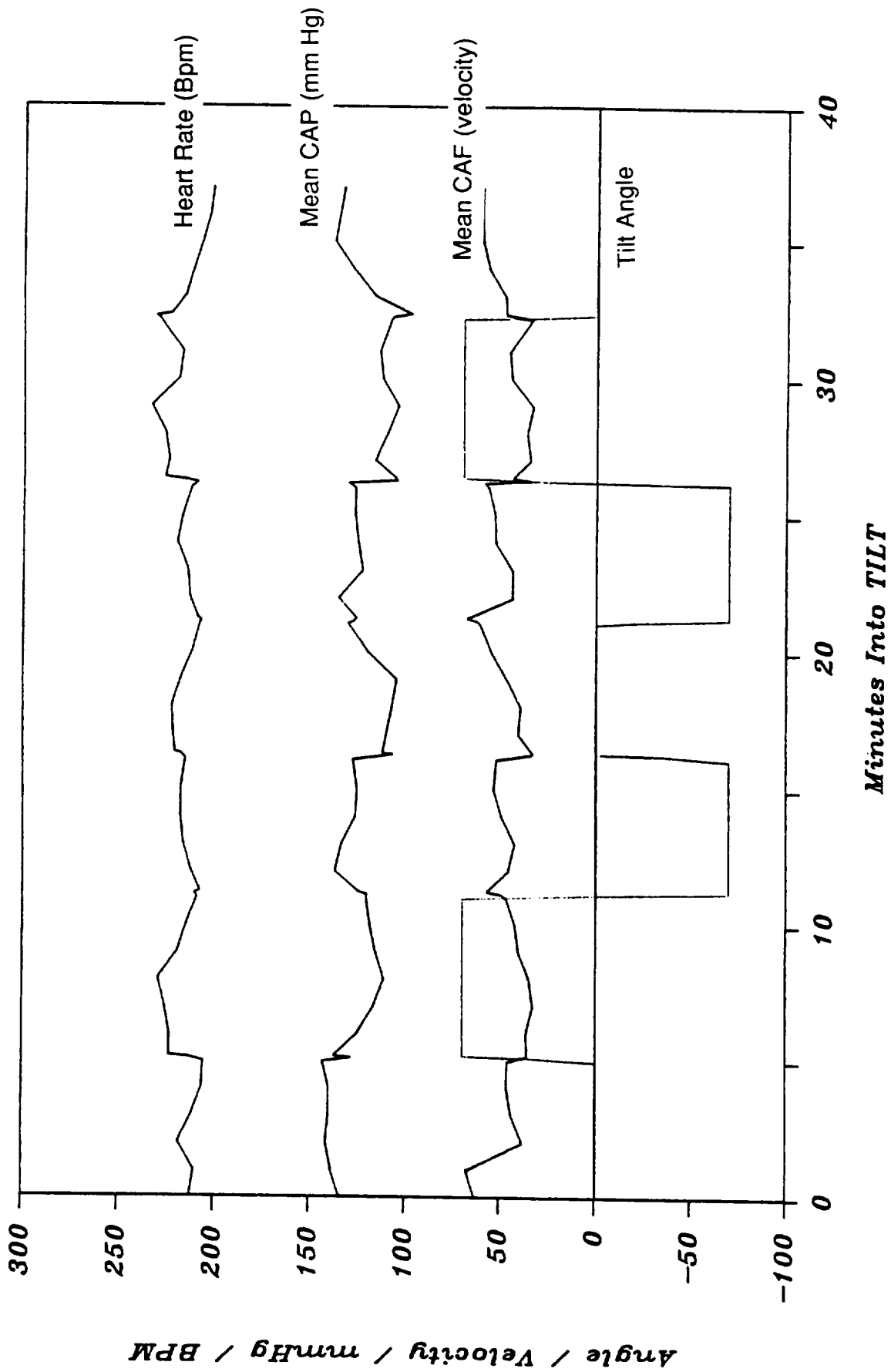

FIGURE V-M. GORDYY TILT DATA  
POST-FLIGHT TILT

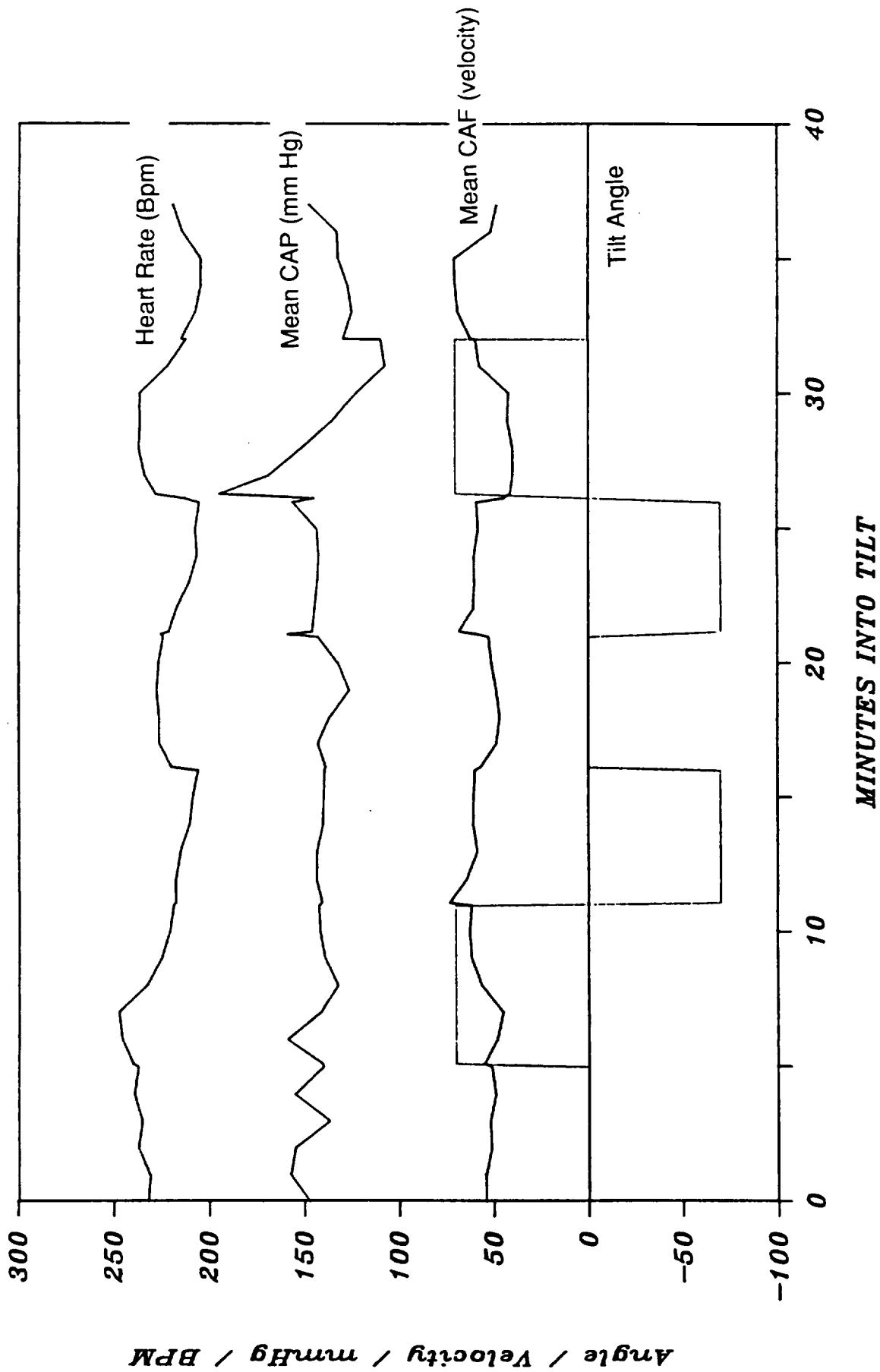

FIGURE V-N. GORDYY TILT DATA  
SYNCHRONOUS CONTROL TILT

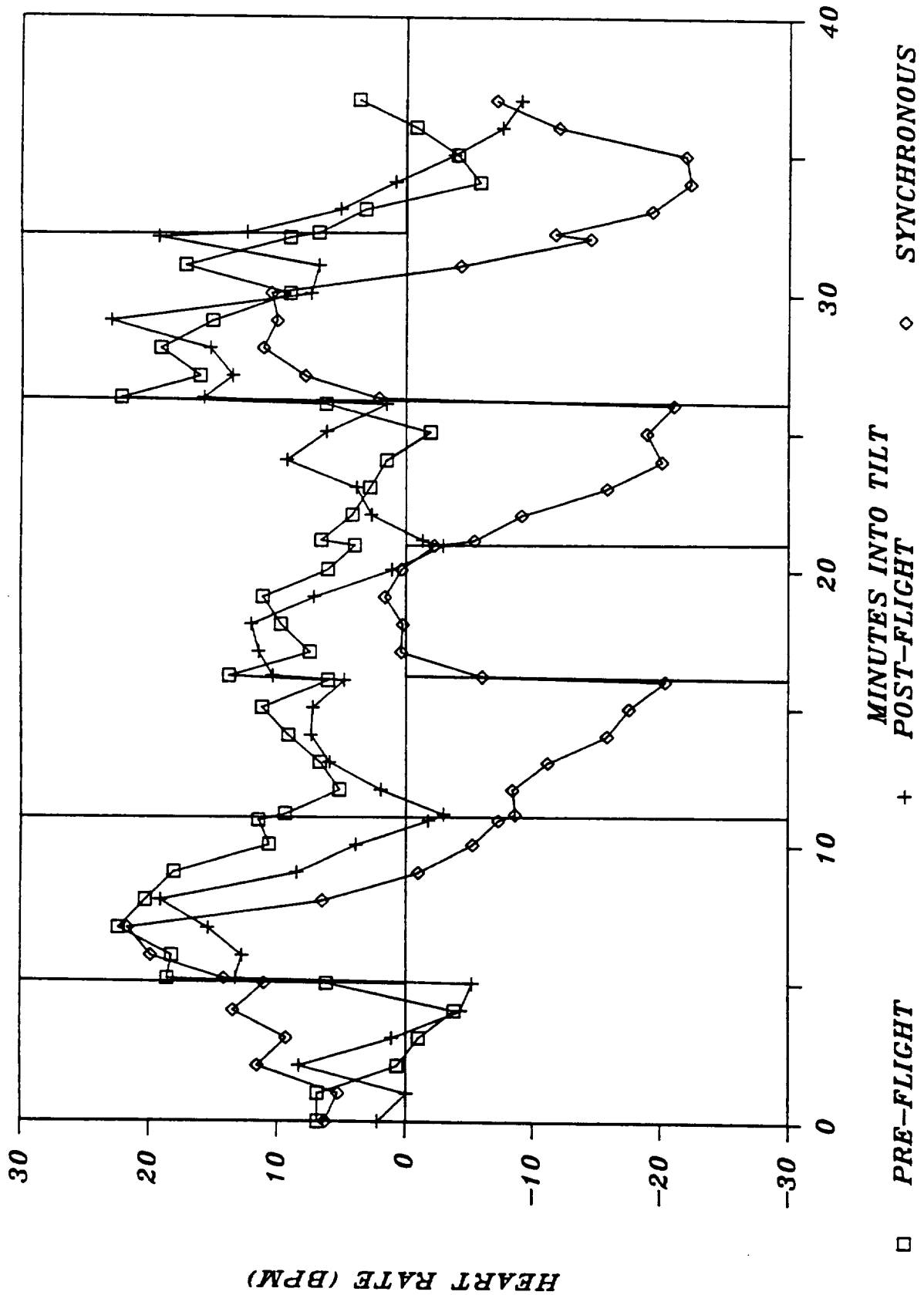

FIGURE V-O. GORDY TILT DATA  
COMPARISON OF DELTA HR FROM CONTROL

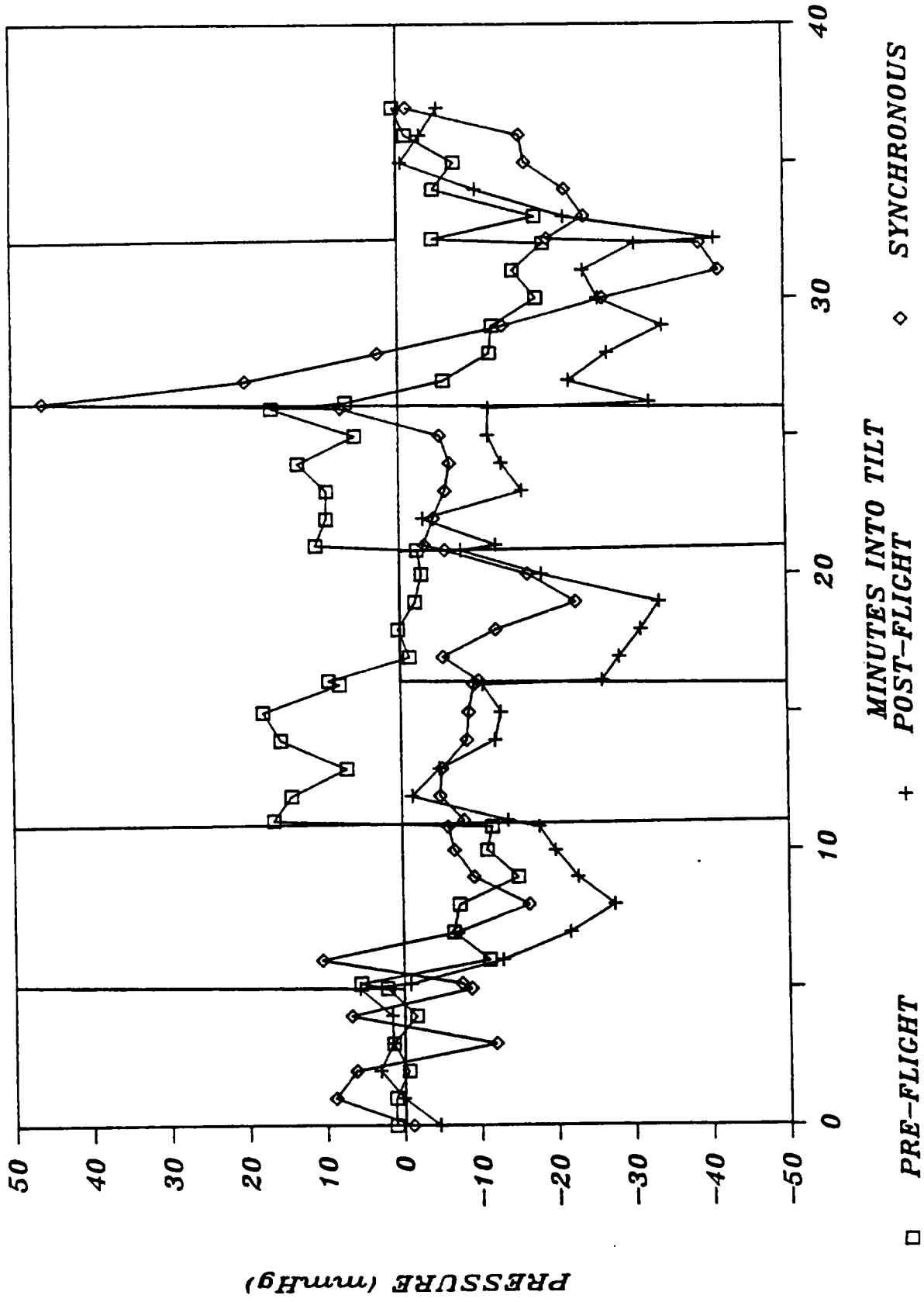

FIGURE V-P. GORDY TILT DATA  
COMPARISON OF DELTA CAP FROM CONTROL

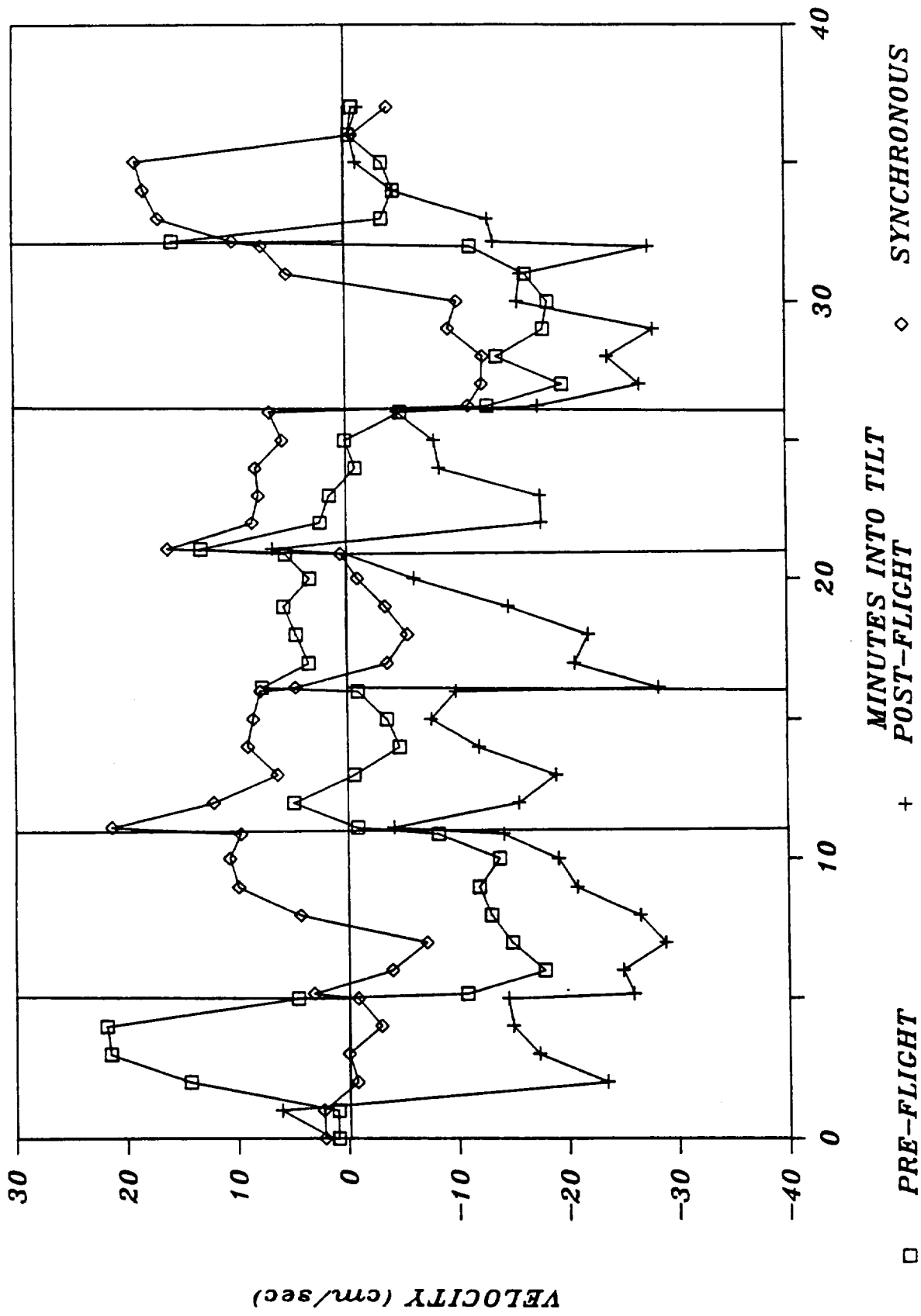

FIGURE V-Q. GORDYY TILT DATA  
COMPARISON OF DELTA CAF FROM CONTROL

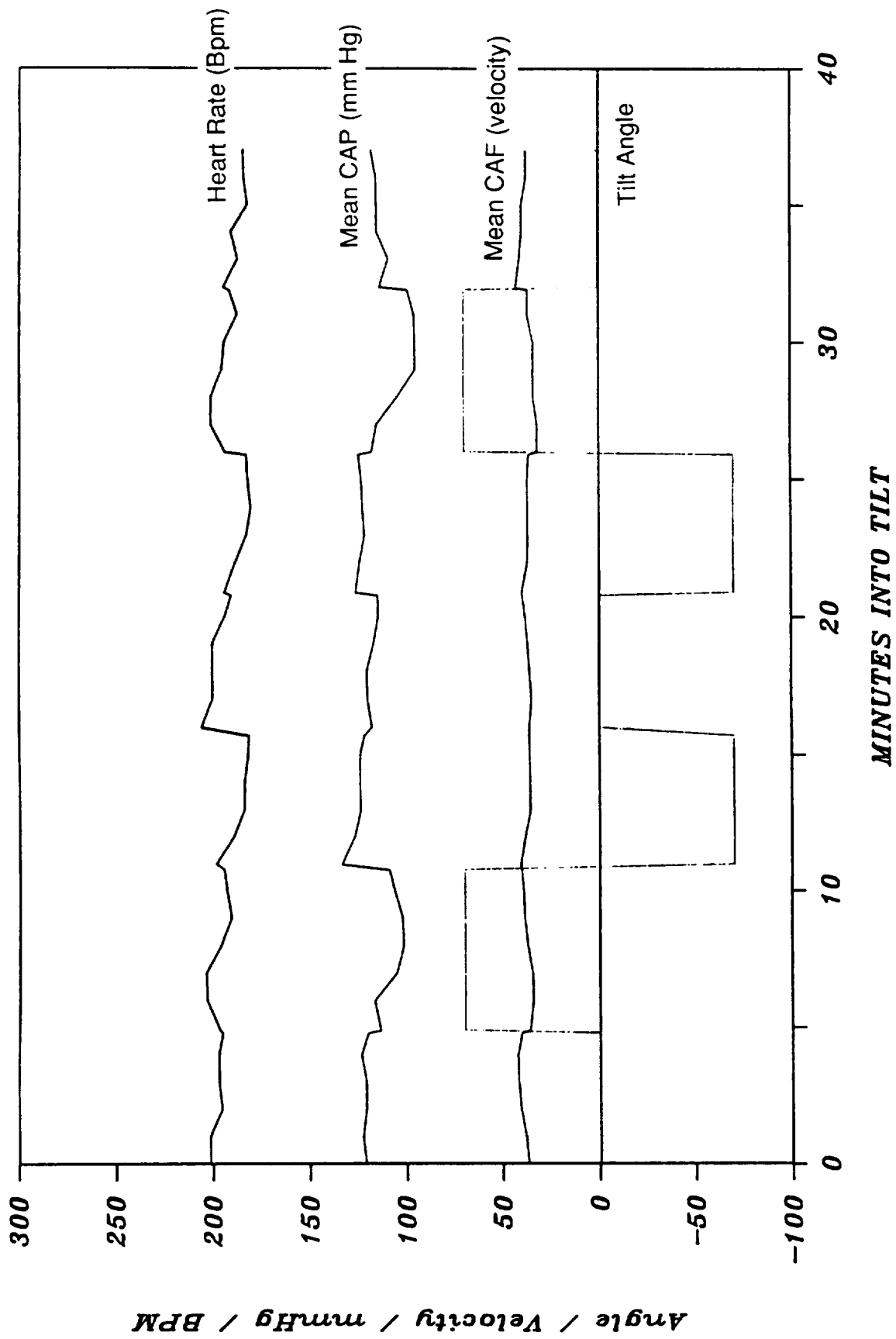

FIGURE V-R. MEAN OF ALL TILTS  
EXCLUDING GORDY POST-FLIGHT

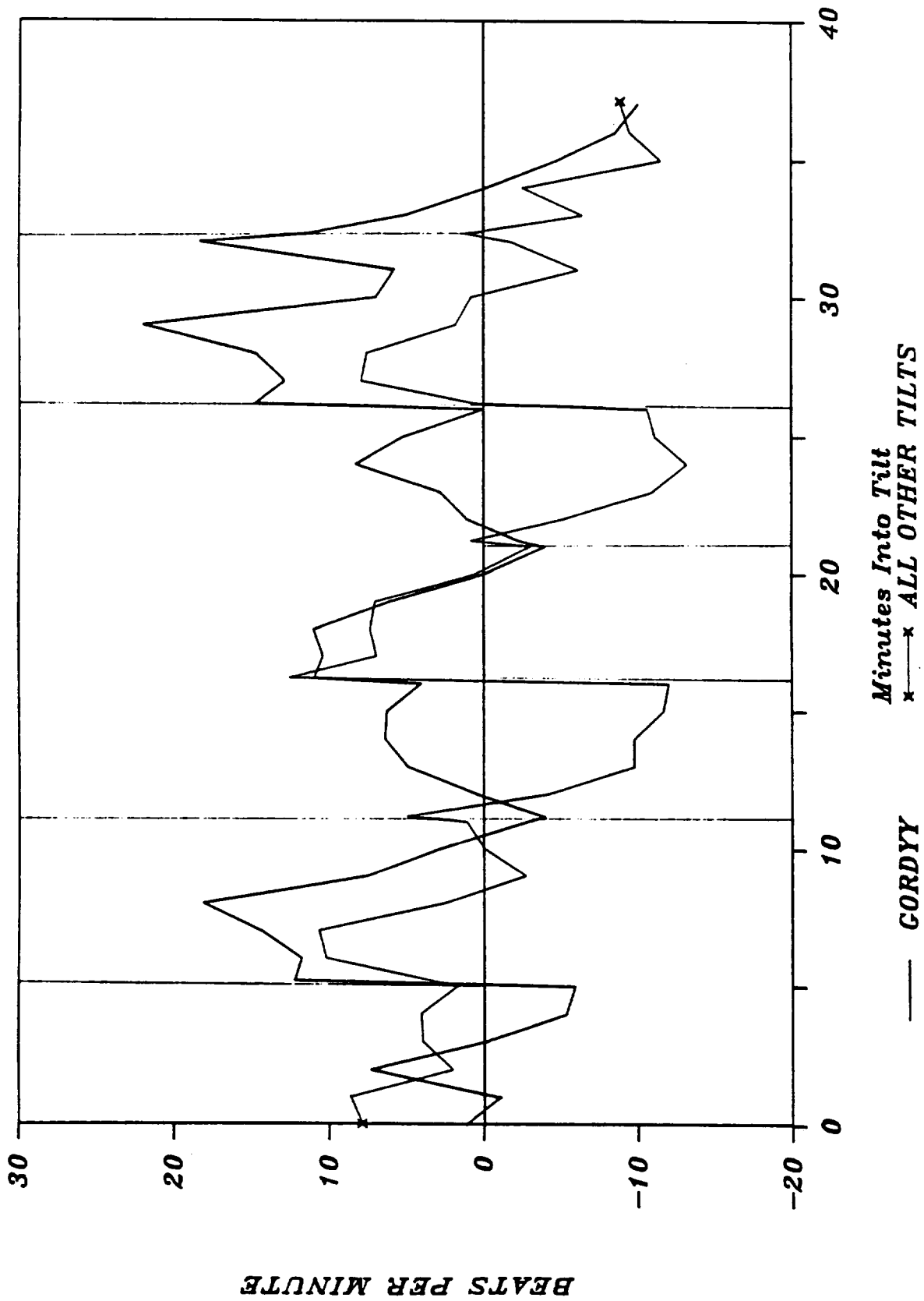

FIGURE V-S. GORDYY POST-FLIGHT VS OTHER TILTS  
DELTA HEART RATE FROM CONTROL



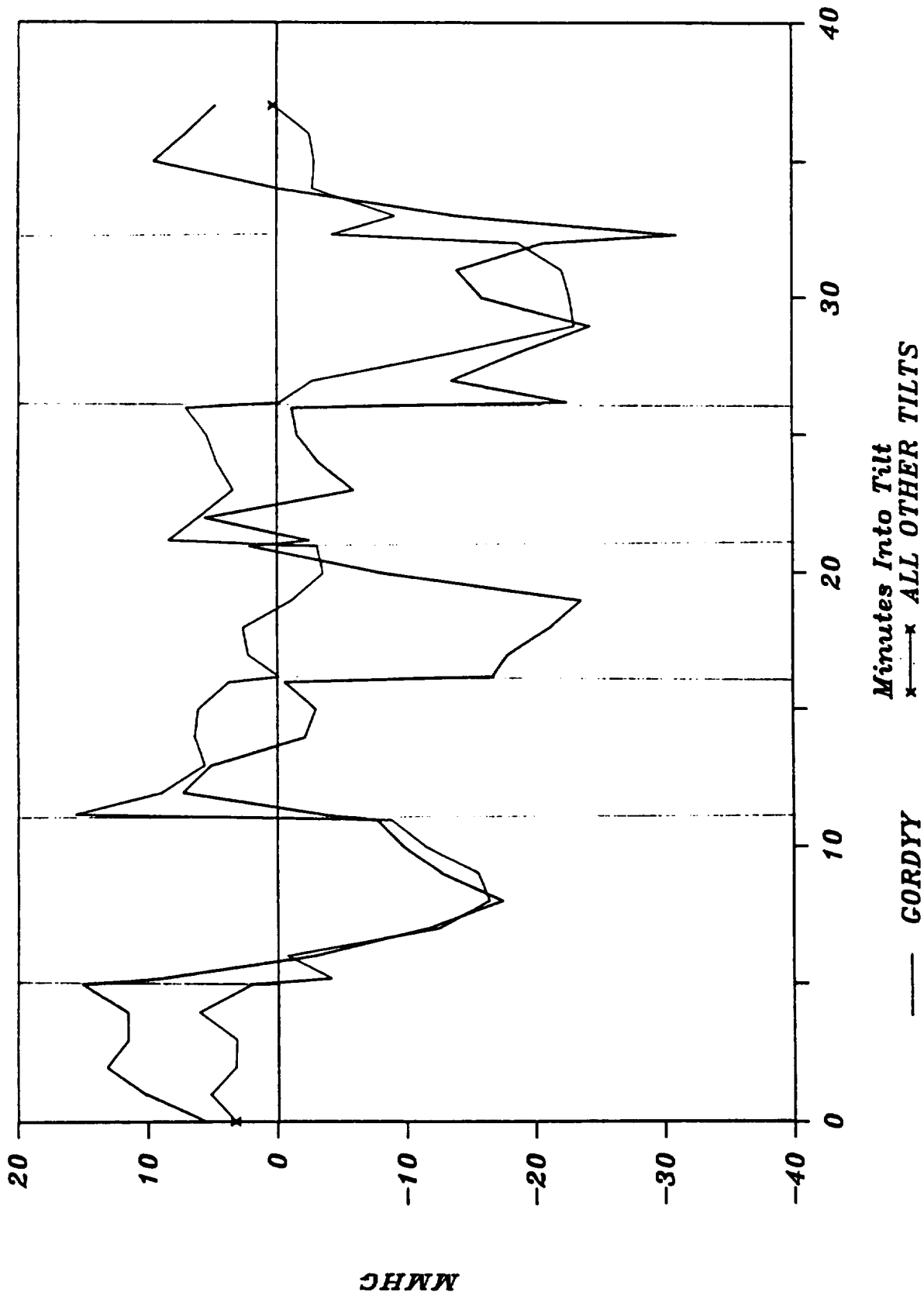

FIGURE V-T. GORDYY POST-FLIGHT VS OTHER TILTS  
 DELTA MEAN CAP FROM CONTROL

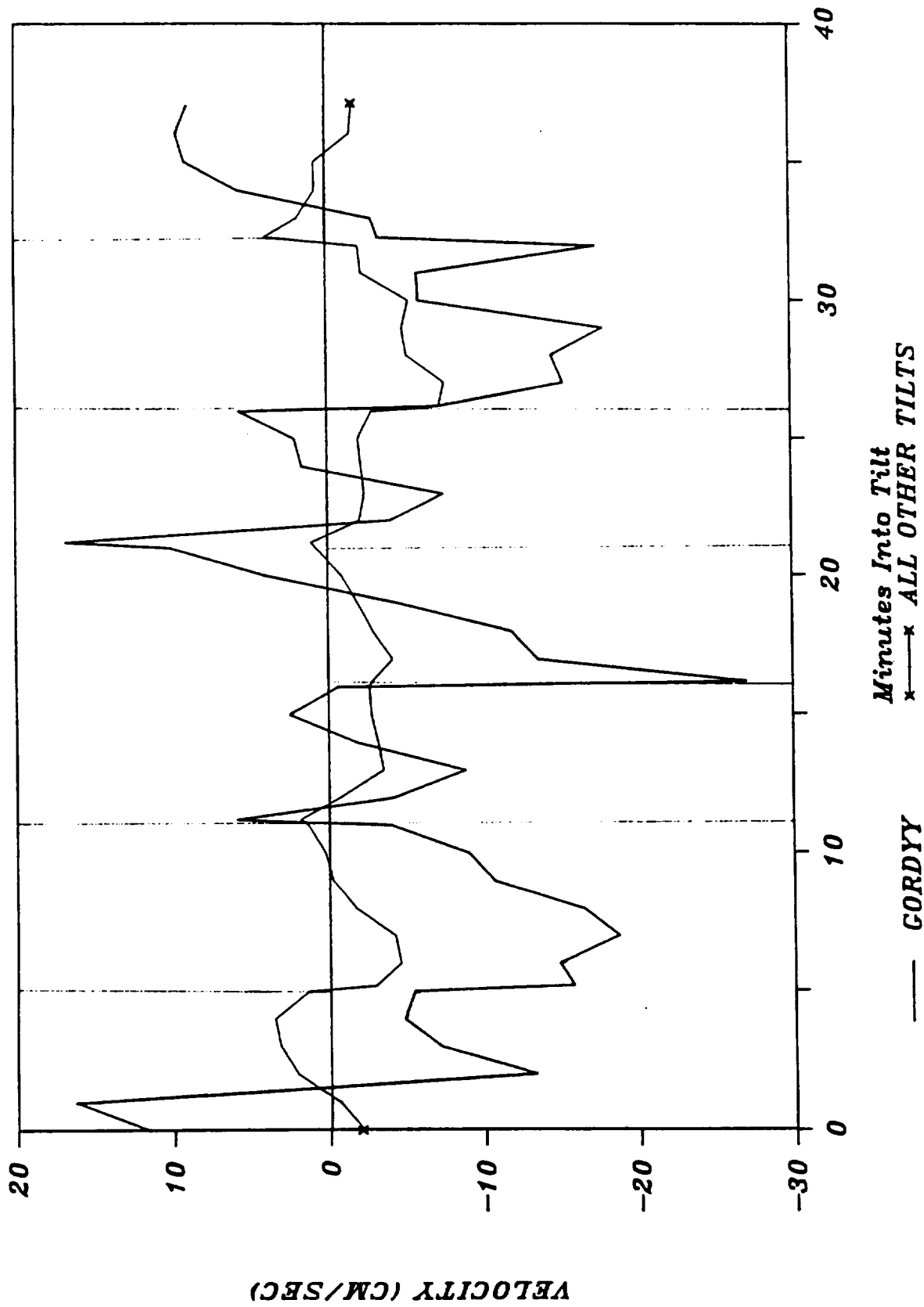

FIGURE V-U. GORDYY POST-FLIGHT VS OTHER TILTS  
DELTA MEAN CAF FROM CONTROL

TABLE 1

CAP (SYS/DIAS.) USING STICK RESULTS (SAMURAI)

	<b>PRE-FLIGHT</b>	<b>POST-FLIGHT</b>	<b>SYNCHRONOUS</b>
Flight Box TCU Time: 227 33:56:24			
	156.5/110.0	196.5/142.8	239.3/176.5
Flight Box TCU Time: 229 23:49:53			
	130.9/76.6	149.3/89.7	204.9/163.0

OVERALL RESULTS

GORDYI

SAKURAI

KVAK

Angle	Mean +/- SE		Mean +/- SE		Mean +/- SE		Mean	SD	SE		
	Pre-Flight	Synchronous	Pre-Flight	Synchronous	Pre-Flight	Synchronous					
										Pre-Flight	Synchronous
HR	0	198 +/- 4.7	188 +/- 2.1	184 +/- 2.8	178 +/- 2.1	162 +/- 8.3	220 +/- 1.6	236 +/- 1.2	195.1	23.49	8.84
	70	202 +/- 3.8	212 +/- 1.2	178 +/- 3.6	166 +/- 2.1	159 +/- 4.9	235 +/- 1.8	232 +/- 4.7	197.7	28.49	10.72
	-70	200 +/- 1.3	188 +/- 2.0	177 +/- 0.4	166 +/- 1.6	133 +/- 1.7	226 +/- 0.9	211 +/- 1.9	185.9	28.57	10.75
	0	201 +/- 5.3	192 +/- 1.2	191 +/- 0.5	188 +/- 4.7	157 +/- 5.6	226 +/- 1.2	226 +/- 0.6	197.3	22.17	8.34
	-70	196 +/- 1.9	184 +/- 2.4	176 +/- 1.1	163 +/- 4.5	139 +/- 1.5	221 +/- 1.2	209 +/- 1.9	184.0	25.82	9.72
	70	199 +/- 5.6	211 +/- 2.9	174 +/- 2.3	170 +/- 5.2	155 +/- 2.9	233 +/- 1.6	229 +/- 3.9	195.9	28.11	10.58
	0	188 +/- 0.3	197 +/- 1.0	190 +/- 3.1	155 +/- 1.7	150 +/- 8.1	218 +/- 1.7	209 +/- 2.7	186.7	23.75	8.94
BP	0	149 +/- 1.5	120 +/- 0.6	104 +/- 2.4	127 +/- 2.6	105 +/- 2.3	100 +/- 0.7	149 +/- 3.9	122.0	19.21	7.23
	70	136 +/- 2.8	121 +/- 2.4	77 +/- 2.7	104 +/- 1.7	79 +/- 5.1	90 +/- 1.2	143 +/- 3.3	107.1	24.83	9.34
	-70	142 +/- 1.0	129 +/- 1.2	87 +/- 2.1	121 +/- 1.4	135 +/- 0.7	113 +/- 1.9	141 +/- 0.8	124.0	17.96	6.76
	0	139 +/- 2.0	120 +/- 0.6	89 +/- 1.7	120 +/- 5.5	118 +/- 3.9	99 +/- 0.6	136 +/- 2.9	117.3	16.78	6.31
	-70	145 +/- 0.5	121 +/- 0.8	86 +/- 2.0	129 +/- 1.2	122 +/- 0.9	111 +/- 1.6	146 +/- 2.4	122.9	19.15	7.21
	70	124 +/- 0.5	121 +/- 1.8	59 +/- 3.6	105 +/- 4.3	79 +/- 6.1	87 +/- 1.9	132 +/- 9.0	101.0	24.93	9.38
	0	143 +/- 2.0	121 +/- 0.8	83 +/- 2.1	120 +/- 3.0	108 +/- 2.7	94 +/- 2.6	133 +/- 3.6	114.6	19.57	7.37
PP	0	36 +/- 0.9	31 +/- 0.2	66 +/- 0.5	69 +/- 0.7	55 +/- 1.8	34 +/- 0.7	52 +/- 1.0	49.0	14.40	5.42
	70	37 +/- 1.3	29 +/- 0.3	57 +/- 1.5	56 +/- 3.3	53 +/- 1.8	32 +/- 0.3	48 +/- 0.9	44.6	10.86	4.09
	-70	16 +/- 2.3	32 +/- 0.3	63 +/- 1.2	61 +/- 0.4	45 +/- 0.7	34 +/- 0.9	52 +/- 1.0	43.3	15.76	5.93
	0	33 +/- 0.6	31 +/- 0.1	64 +/- 1.0	67 +/- 1.2	45 +/- 2.1	34 +/- 1.1	48 +/- 0.9	46.0	13.67	5.14
	-70	22 +/- 2.2	30 +/- 0.2	61 +/- 1.1	61 +/- 1.3	52 +/- 0.6	30 +/- 1.1	55 +/- 0.3	44.4	15.30	5.76
	70	35 +/- 0.8	27 +/- 0.4	50 +/- 1.6	56 +/- 3.8	45 +/- 1.1	32 +/- 0.6	45 +/- 1.8	41.4	9.63	3.63
	0	38 +/- 0.4	32 +/- 0.4	61 +/- 0.2	64 +/- 0.3	47 +/- 1.2	39 +/- 0.5	51 +/- 0.8	47.4	11.15	4.19
BF	0	35 +/- 1.7	21 +/- 0.2	39 +/- 1.5	39 +/- 1.4	34 +/- 0.8	70 +/- 3.6	52 +/- 0.8	41.4	14.41	5.42
	70	34 +/- 2.1	19 +/- 0.2	44 +/- 0.7	43 +/- 0.8	25 +/- 0.4	44 +/- 1.2	56 +/- 2.9	37.9	11.75	4.42
	-70	31 +/- 1.0	20 +/- 0.2	30 +/- 0.3	35 +/- 0.5	24 +/- 0.5	56 +/- 1.6	61 +/- 0.9	36.7	14.56	5.48
	0	33 +/- 5.2	19 +/- 0.1	33 +/- 0.6	37 +/- 1.3	29 +/- 1.2	62 +/- 0.4	49 +/- 1.0	37.4	13.03	4.90
	-70	34 +/- 0.5	19 +/- 0.2	29 +/- 0.4	37 +/- 1.3	24 +/- 0.2	57 +/- 1.2	59 +/- 0.4	37.0	14.39	5.42
	70	30 +/- 1.1	16 +/- 0.2	40 +/- 0.8	38 +/- 1.5	31 +/- 1.1	41 +/- 1.1	47 +/- 3.4	34.7	9.38	3.53
	0	35 +/- 0.2	18 +/- 0.2	33 +/- 0.8	40 +/- 0.8	32 +/- 1.2	51 +/- 4.0	62 +/- 4.5	38.7	13.18	4.96

LEGEND:

HR - Heart Rate, BPM  
 BP - Mean Carotid Blood Pressure, mmHg  
 PP - Pulse Pressure, mmHg  
 BF - Mean Carotid Blood Flow Velocity, cm/sec

Angle - Tilt Table Angle, degrees  
 SD - Standard Deviation  
 SE - Standard Error

### III. COSMOS 1667 DOCUMENT OVERVIEW

Significant documents relating to the Cosmos 1667 mission are briefly described below.

A. Cosmos 1667: Primate Cardiovascular Experiment Final Science Report.

This report, (a first draft), contains preliminary analyses of the primate cardiovascular data collected during the July 1985 mission and subsequent postflight studies conducted one month later. It supplies background information, objectives, methods, results and discussion of the Cosmos 1667 CV experiment.

B. Cosmos 1514 and 1667: Comparison Report of Primate Cardiovascular Experiment.

Submitted 4 months after the final science report (draft), it presents a complete comparison of the cardiovascular data collected on Cosmos 1514 and 1667. Statistical comparison tables and graphs are included. Methods and hardware are described only briefly.

C. Final Reports of U.S. Monkey and Rat Experiments Flown on the Soviet Satellite Cosmos 1514.

This is a technical memorandum detailing the mission configuration, experiment hardware, objectives, methods, results and discussion for the complete complement of U.S. experiments conducted aboard Cosmos 1514 in December 1983. Primate Cardiovascular Experiment hardware and integration is described in detail.

D. Cosmos '85: Cardiovascular Measurements Experiment Specifications and Procedures Manual.

This document was written in preparation for the CV Experiment aboard Cosmos 1667. It provides all required information for the identification, assembly, checkout, operation, and functional verification of U.S. instrumentation for the CV study.

E. Cardiovascular Results

This 4-volume report contains detailed data for the CV experiment.

Volume I: Final Report of Cosmos 1514 and 1667 Cardiovascular Results  
Volume II: Twenty Beat Snapshots (data segments)  
Volume III Summary of Tilt Events  
Volume IV: Analysis of Impedance

F. Krotov, V.P., H Sandler, V.S. Magedov, J.W. Hines, A.M. Badakva, A.N.Nazin:

Hemodynamics in Primates at an Early Stage of Adaptation to Microgravity, *Kosm. Biol. i Aviakosm. Med. (Space Biology and Aerospace Medicine)*, 1988, No. 5, pp 33-39. Translated from the Russian

This is a journal report, published in Russian, on the joint U.S./U.S.S.R. Cardiovascular Experiment on Cosmos 1667. A copy of an English translation of the text and figure legends is available through the NASA ARC Cosmos Project Manager (see Preface to this Technical Memorandum).



# REPORT DOCUMENTATION PAGE

*Form Approved*  
OMB No. 0704-0188

Public reporting burden for this collection of information is estimated to average 1 hour per response, including the time for reviewing instructions, searching existing data sources, gathering and maintaining the data needed, and completing and reviewing the collection of information. Send comments regarding this burden estimate or any other aspect of this collection of information, including suggestions for reducing this burden, to Washington Headquarters Services, Directorate for Information Operations and Reports, 1215 Jefferson Davis Highway, Suite 1204, Arlington, VA 22202-4302, and to the Office of Management and Budget, Paperwork Reduction Project (0704-0188), Washington, DC 20503.

<b>1. AGENCY USE ONLY (Leave blank)</b>		<b>2. REPORT DATE</b> May 1994	<b>3. REPORT TYPE AND DATES COVERED</b> Technical Memorandum	
<b>4. TITLE AND SUBTITLE</b> Final Report of the U.S. Experiment Flown on the Soviet Biosatellite Cosmos 1667			<b>5. FUNDING NUMBERS</b>  199-70-12	
<b>6. AUTHOR(S)</b> John W. Hines, and Michael G. Skidmore, Editors				
<b>7. PERFORMING ORGANIZATION NAME(S) AND ADDRESS(ES)</b> Ames Research Center Moffett Field, CA 94035-1000			<b>8. PERFORMING ORGANIZATION REPORT NUMBER</b>  A-94032	
<b>9. SPONSORING/MONITORING AGENCY NAME(S) AND ADDRESS(ES)</b> National Aeronautics and Space Administration Washington, DC 20546-0001			<b>10. SPONSORING/MONITORING AGENCY REPORT NUMBER</b>  NASA TM-108803	
<b>11. SUPPLEMENTARY NOTES</b> Point of Contact: Michael G. Skidmore, Ames Research Center, MS 236-5, Moffett Field, CA 94035-1000; (415) 604-6069				
<b>12a. DISTRIBUTION/AVAILABILITY STATEMENT</b>  Unclassified — Unlimited Subject Category 55			<b>12b. DISTRIBUTION CODE</b>	
<b>13. ABSTRACT (Maximum 200 words)</b>  Two male young-adult rhesus monkeys were flown on the Soviet Biosatellite Cosmos 1667 for seven days from July 10-17, 1985. Both animals were instrumented to record neurophysiological parameters. One animal, Gordyy, was additionally instrumented to record cardiovascular changes. Space capsule and environmental parameters were very similar to those of previous missions. On Cosmos 1514, which flew for five days in 1983, one animal was fitted with a left carotid artery cuff to measure blood pressure and flow velocity. An additional feature of Cosmos 1667 was a postflight control study using the flight animal. Intermittent postural tilt tests were also conducted before and after spaceflight and synchronous control studies, to simulate the fluid shifts associated with spaceflight. The experiment results support the conclusion derived from Cosmos 1514, that significant cardiovascular changes occur with spaceflight. The changes most clearly seen were rapid initial decreases in heart rate and further decreases with continued exposure to microgravity. The triggering mechanism appeared to be a headward shift in blood and tissue fluid volume which, in turn, triggered adaptive cardiovascular changes. Adaptive changes took place rapidly and began to stabilize after the first two days of flight. However, these changes did not plateau in the animal by the last day of the mission.				
<b>14. SUBJECT TERMS</b> Cosmos, Biosatellite, Flight experiments			<b>15. NUMBER OF PAGES</b> 136	
			<b>16. PRICE CODE</b> A07	
<b>17. SECURITY CLASSIFICATION OF REPORT</b> Unclassified	<b>18. SECURITY CLASSIFICATION OF THIS PAGE</b> Unclassified	<b>19. SECURITY CLASSIFICATION OF ABSTRACT</b>	<b>20. LIMITATION OF ABSTRACT</b>	