

NASA Technical Memorandum 103970

Flight Testing of a Luminescent Surface Pressure Sensor

B. G. McLachlan, J. H. Bell, J. Espina, Ames Research Center, Moffett Field, California
J. Gallery, M. Gouterman, C. G. N. Demandante, University of Washington, Seattle, Washington
L. Bjarke, Dryden Flight Research Facility, Edwards, California

October 1992



National Aeronautics and
Space Administration

Ames Research Center
Moffett Field, California 94035-1000



FLIGHT TESTING OF A LUMINESCENT SURFACE PRESSURE SENSOR*

B. G. McLachlan,** J. H. Bell,** J. Espina,**
J. Gallery,† M. Gouterman,† C. G. N. Demandante,† and L. Bjarke‡

Ames Research Center

Summary

NASA Ames Research Center has conducted flight tests of a new type of aerodynamic pressure sensor based on a luminescent surface coating. Flights were conducted at the NASA Ames-Dryden Flight Research Facility. The luminescent pressure sensor is based on a surface coating which, when illuminated with ultraviolet light, emits visible light with an intensity dependent on the local air pressure on the surface. This technique makes it possible to obtain pressure data over the entire surface of an aircraft, as opposed to conventional instrumentation, which can only make measurements at pre-selected points. The objective of the flight tests was to evaluate the effectiveness and practicality of a luminescent pressure sensor in the actual flight environment. A luminescent pressure sensor was installed on a fin, the Flight Test Fixture (FTF), that is attached to the underside of an F-104 aircraft. The response of one particular surface coating was evaluated at low supersonic Mach numbers ($M = 1.0 - 1.6$) in order to provide an initial estimate of the sensor's capabilities. This memo describes the test approach, the techniques used, and the pressure sensor's behavior under flight conditions. A direct comparison between data provided by the luminescent pressure sensor and that produced by conventional pressure instrumentation shows that the luminescent sensor can provide quantitative data under flight conditions. However, the test results also show that the sensor has a number of limitations which must be addressed if this technique is to prove useful in the flight environment.

Nomenclature

A, B	Stern-Volmer sensitivity coefficients
dB	Decibel
IRIG	Inter-Range Instrumentation Group
LPS	Luminescent Pressure Sensor

* Paper #3 in a series on Luminescent Aerodynamic Imaging. For papers #1-2 see references.

** Ames Research Center, Moffett Field, CA 94035-1000.

† University of Washington, Seattle, WA 98195.

‡ Dryden Flight Research Facility, Edwards, CA 93523-0273

M	Mach number
I	Intensity of light emitted by luminescent paint
I_0	Intensity of light emitted by luminescent paint at a known reference condition
FTF	Flight Test Fixture
Hz	Hertz
p	Surface pressure
p_0	Surface pressure at a known reference condition
UV	Ultraviolet

1.0 Introduction

Current data reduction and analysis techniques, aided by advances in computer technology, make it possible to evaluate experiments which generate very large numbers of individual measurements. The actual means of making such measurements, however, have quite often not kept pace with these advances. The measurement of surface pressure on aircraft and wind tunnel models is a case in point. Conventional surface pressure measurement systems, based on individual transducers, can only measure pressure at preselected points on the aircraft or model surface. Conventional systems must be built into the aircraft or model itself, and their size and cost limit the number of points at which pressure can be measured. If the pressure variations of interest occur away from the pressure taps, or with a spatial scale smaller than the tap spacing, important data is not obtained.

A new means of measuring surface pressure has recently been developed by the NASA Ames Research Center and the University of Washington (Kavandi, 1990). This method depends on the quenching by molecular oxygen of the long lived luminescence of certain dyes. When a molecule absorbs a photon, it is raised to an excited state from which it can return to the ground state in a variety of ways. In luminescent materials the transition back to the ground state usually involves the emission of a new, longer-wavelength photon. In some luminescent materials, the presence of oxygen catalyzes the transition to the ground state without the emission of a photon. The more oxygen present, the fewer photons emitted. Thus, for a given level of excitation, the brightness of the luminescence varies inversely with the oxygen level in the environment. Since oxygen is a fixed mole fraction of the air, the material's brightness varies inversely with pressure. When the luminescent material is applied as a coating to an aerodynamic surface, it becomes possible to relate the brightness of the surface at any given point to the pressure at that point.

As illustrated schematically in figure 1, the luminescent pressure measurement system consists of three components: the coated surface itself, an ultraviolet lamp to excite the coating, and a video camera to record the light emitted by the coating. In addition to pressure, the brightness of the coating at a given point depends on the intensity of UV illumination, the coating thickness at that point, and some other factors which will be discussed below. These effects can be removed by first taking an image at a known reference pressure. When the reference image is ratioed with an image taken under the test conditions, the effects of uneven illumination and coating thickness are factored out, leaving an image whose brightness varies according to the ratio between the test and reference pressures. Thus pressure and luminescence intensity can be related via the equation:

$$\frac{I_0}{I} = A + B \frac{p}{p_0} \quad (1)$$

Here, p and I represent pressure and luminescence intensity, respectively, while p_0 and I_0 represent these quantities at a known, uniform pressure level, and A and B are coefficients which depend on the luminescent material.

The advantages of this technique are clear. The coating is not much more expensive or difficult to apply than standard paints. Air pressure at every point on the surface can be measured simultaneously, at whatever resolution the video camera is capable of. With a typical CCD camera, pressure can be measured at a quarter of a million individual points, as opposed to the few hundreds which are the practical limit of conventional pressure taps. Furthermore, the camera can easily be adjusted to give close up views of features of interest, something which is impossible with conventional techniques. Considerable cost savings can also be achieved. Not only are the camera, UV lamps, optical filters, and surface coating inexpensive compared to the cost of a few dozen pressure taps, but the camera and lamps can be transferred easily from one test to another, while the labor cost of installing pressure taps is lost once testing on a particular test article is complete.

Luminescent pressure sensors also have a number of undesirable characteristics. The present coating is sensitive to surface temperature as well as pressure, necessitating the application of a correction factor. It also degrades with continued exposure to ultraviolet light, and so must be reapplied at regular intervals. Furthermore, its time response is on the order of a second (Kavandi *et al.*, 1990; McLachlan *et al.*, 1992), which makes it unsuitable for measurements of pressure fluctuations more rapid than 1 Hz. In any case, measurement of fluctuations at greater than 30 Hz would require the use of specialized video equipment. The limitations of the video system also determine the sensitivity of the technique to small changes in pressure. Currently, measurement precision is limited by the dynamic range of the video data acquisition system. The standard video camera/digitizer combination used in the current test has a resolution of no more than 8 bits, giving a maximum dynamic range of 256:1 (48 dB). The actual sensitivity of the paint is not yet known, but is at least an order of magnitude greater than this. The current capabilities of luminescent pressure sensors do not compare favorably with conventional pressure transducers, which can resolve pressure fluctuations in the hundreds of kHz with dynamic ranges greater than 50,000:1 (94 dB). However, the dynamic range and time response listed here by no means represent the theoretical limits

of luminescent pressure sensors. It is believed that further research will yield coatings and detection systems with substantially better characteristics.

In order to support further development of luminescent pressure sensor systems, it is necessary to gain experience under actual experimental conditions. Flight experiments typically constitute a severe test of the ability of any measurement system to produce accurate, reliable data. In addition, while flight testing can benefit substantially from luminescent pressure sensors, it is necessary to determine whether this technique is sufficiently robust before extensive use can be contemplated. Accordingly, the present experiment was designed to demonstrate a luminescent pressure sensor system under actual flight conditions, making direct comparison with conventional pressure measurements.

A great many people at the NASA Ames-Dryden Flight Research Facility contributed substantially to making this flight test successful. We would especially like to thank our liaison at Dryden, John Saltzman, for his unstinting support, and to recognize the contribution of other Dryden personnel, especially James Yamanaka, Jim "B.B." Smolka, Gina Rodriguez, Harry Chiles, and Bob Gonzales. The special effort required of the Dryden flight crew to fly the aircraft at night should also be noted.

2.0 Experimental Equipment and Methods

2.1 Aircraft

A specially equipped F-104G aircraft was used for this test. This aircraft has a flight trajectory guidance system through which engineering parameters calculated on a ground-based computer are uplinked in real time to a cockpit display. The highly accurate values of Mach number, Reynolds number, and sideslip available through the display allow the pilot to fly precise experimental profiles. This F-104 has also been modified to carry a ventral fin, the Flight Test Fixture (FTF), within which test equipment can be installed. The FTF is described in more detail below. Together, the FTF and F-104 form a complete flight test facility (Meyer, 1982), which is shown in figure 2.

2.2 Flight Test Fixture (FTF)

The FTF is a low aspect ratio fin mounted on the lower fuselage centerline of the F-104. Figure 3 shows the FTF with its side panels removed, revealing interior details. It has a length (chord) of 205.7 cm (81.0 in.), a span of 61.0 cm (24.0 in.), and a constant thickness of 16.2 cm (6.4 in.) except at the forebody. The forebody has a radiused shape incorporating the front portion of a symmetric supercritical airfoil. The FTF is constructed mostly of aluminum, and weighed roughly 154 kg (340 lb) during the present experiment. Internally, the FTF is subdivided into four bays. The first bay is taken up by the FTF's power distribution system and data acquisition system. The second bay and third bay hold the FTF's air data system electronics and surface pressure measurement system, respectively. The fourth bay is available for user equipment, and was used for the Luminescent Pressure Sensor (LPS). In the current

study, the air data system electronics were removed from the second bay and replaced with a power supply for the UV lamp used by the LPS.

For measuring surface pressures, the FTF is equipped with a 48-port mechanically scanned pressure transducer; two 32-port, electronically scanned, multiple pressure transducer assemblies; and two individual transducers. The FTF also has its own air data system consisting of a pitot static probe mounted on a boom extending ahead of the leading edge. As explained above, this was not used in the present experiment, since its associated electronics were removed. Flight conditions were provided by the aircraft air data system exclusively. During the current experiment, one of the 32-port transducers was connected to 15 pressure taps. Five taps were at locations on the forebody, and were used to corroborate air data from the aircraft system. The other ten were on the surface coated with the luminescent sensor, so that conventional pressure measurements could be directly compared with the new technique. Data was acquired via a pulse-code modulation system at 5.2 Hz. Data was both telemetered to a ground computer and recorded onboard the aircraft.

2.3 Luminescent Pressure Sensor (LPS) System

The LPS system built for this experiment was designed primarily for simplicity, low cost, and high signal to noise ratio. This last requirement was dictated by flight conditions. Light is emitted by the luminescent material in a narrow wavelength range around 650 nm, and a filter is used to prevent light of other wavelengths from being recorded by the video camera. Ambient light around 650 nm produces a spurious signal which cannot be separated from the actual data. In the laboratory, the researcher simply turns off the lights, but this is not practical in flight. In particular, it was initially believed that, due to safety concerns, the F-104 test aircraft could not be flown at night. Although night flights were later performed, the LPS was designed in anticipation of having to make measurements during low daylight conditions.

In order to maximize the UV illumination intensity, a self-contained internal system was built and mounted inside the F-104 Flight Test Fixture (FTF), as shown in figure 2. The system itself is sketched in figure 4, and consists of three major parts. First, light from a metal halide arc lamp with a UV specific optical filter is directed onto a mirror which reflects the UV light out through a plexiglas window mounted in the side of the FTF. The outside of the window is coated with the luminescent material, which glows when struck by the UV light. The luminescence is emitted in all directions. A portion of the emitted light comes back through the window, is reflected by the mirror and is recorded by the video camera. The disadvantage of this configuration is that pressure can be measured only over one relatively small part of the FTF. The advantage, however, is a high level of UV illumination, due to close placement of the lamp to the coated surface. In addition, the system has the virtue of being completely self-contained, with the exception of the UV lamp power supply, which is located remotely due to space limitations. The use of this configuration required some changes in the formulation of the luminescent coating, which are discussed in the next section.

The UV lamp consisted of a metal halide arc lamp driven by a resistively ballasted DC power supply. The igniter circuit used high voltage (800 V) spikes to establish the arc, which

was then maintained by the DC current. The power supply, which was built in-house, limited the bulb to no more than 5 amps at 30 V, for an input power of 150 watts.

The video camera installed in the LPS was a Pulnix TM-34K CCD camera, modified into a remote head configuration for ease of installation in confined spaces. For this application, automatic gain control was disabled and the proportionality constant, γ , was set to 1. (Setting $\gamma = 1$ ensures a nominally linear response of the camera voltage output to changes in light intensity; this parameter is usually set so as to give a non-linear response for higher dynamic range.) The camera's response to changes in light intensity was determined to be linear to within less than 0.5%. The TM-34K was chosen because it was flight-qualified hardware, rather than for its suitability for LPS measurements. In particular, the automatic gain control cannot be fully disabled, and this results in a slow variation in image brightness over a period of several minutes. Fortunately, the effects of this variation could be factored out with the calibration scheme described in section 4.0.

The LPS was tested at NASA Ames in accordance with NASA Ames-Dryden Flight Research Facility Process Specification No. 21-2 (ADFRF 1989), and cleared for flight with some restrictions on the operating envelope of the UV lamp power supply. Specifically, due to the possibility of arcing within the power supply at higher altitudes, the UV lamp was not to be started above 5,000 ft altitude, and not to be operated above 35,000 ft.

When the LPS hardware was built, there was some concern that it would be installed in a section of the FTF over which there was a relatively flat pressure distribution. It was felt that the LPS's capabilities would be more easily evaluated if there was a significant pressure variation over the test surface. Accordingly, the FTF was fitted with an external projection designed to create a local pressure variation. This projection consisted of a short cylinder which was mounted normal to the surface of the FTF, just behind the LPS test surface. Ideally, the bow shock from the cylinder would impinge upon the test surface, providing an easily measured pressure variation. This proved to be unnecessary, however, as the "natural" flow provided a suitable pressure variation across the FTF.

2.4 Luminescent Pressure Paint

2.4.1 Formulation

The standard luminescent pressure paint consists of a silicone resin solution that is doped with platinum octaethyl porphyrin (PtOEP) (Kavandi, 1990). The method of application of the paint in the current study differed from that used in previous wind tunnel work. In previous studies, where the paint was applied to an opaque surface, an undercoat of white paint was applied first in order to enhance signal strength. The geometry of this configuration is shown in figure 5(a). In contrast, the flight test LPS system employed the geometry shown in figure 5(b). The flight geometry precluded use of a white paint backing layer since light could not pass through a white undercoat, and an overcoat would inhibit oxygen diffusion. Unfortunately, when standard pressure paint is applied directly to the plexiglas, the signal collected is very weak.

Some form of coating signal enhancement for the flight test geometry was highly desirable. Since titanium dioxide (TiO_2) is one of the main pigments used in white paint, small amounts

of the powder were added to the standard pressure paint in order to enhance the signal. The TiO_2 acts as a scattering agent in the film. It causes the exciting UV light to spend more time in the film and thereby increases the probability that a molecule of PtOEP will become excited.

A very finely powdered rutile grade TiO_2 was selected. A fine powder is not easily mixed into a large amount of liquid. A concentrated dispersion was first made, from which aliquots were drawn and added to the pressure paint. A series of samples was prepared with increasing amounts of scattering agent in search of maximum signal enhancement. Figure 6 shows the variation in the intensity of the emitted light with increasing amounts of TiO_2 added to the coating. As expected, there is a region where addition of scatterer increases the signal by increasing the effective path length within the media. However, there comes a point where signal begins to suffer because the light does not penetrate deeply enough into the sample. At the maximum of the curve in figure 6, the signal is better than 2.5 times brighter than the sample without added scattering agent.

2.4.2 Calibration — Front versus Back Illumination

For calibration in the laboratory, a sample of the sensor paint is placed within a variable-pressure chamber, from which its response to pressure changes can be viewed. A typical laboratory calibration setup is shown in figure 7. It is not obvious that calibration parameters obtained in the wind tunnel test geometry of figure 5(a) would hold for the flight test geometry of figure 5(b). In geometry 5A, the coating is observed from the side exposed to air. In geometry 5B, it is observed from the back side, which is not in contact with air. To minimize any possible difference, film thickness was kept on the order of 20 microns. To investigate any possible difference, calibration data was collected from both front and back illumination of TiO_2 -containing films. The equipment shown in figure 7 was used to obtain the calibration curves shown in figure 8. These curves show only a slight difference in fitting parameters. The difference is most likely due to thermal drift, since the sample chamber was not thermostated.

2.4.3 Calibration — Effects of Replenishing

During wind tunnel testing it is customary to replenish the film as the signal is lost to degradation. This is achieved by applying additional coats of paint over the existing one. During front face illumination there is little error introduced in this operation. However, when viewing the luminescence from the back, the surface phenomena can become obscured as more layers are added. In order to understand these effects, the response of the film was observed as the paint was repetitively degraded and replenished with fresh paint. Calibration data was collected from a freshly painted surface and then the surface was exposed to excitation light for 30 min. A replenishing coat was applied and the procedure was repeated 3 times. (The equipment shown in figure 7 was used for this experiment.) The series of calibration curves obtained are given in figure 9. The decrease in slope after subsequent applications indicates a substantial loss of sensitivity after the second spraying. Exposure to light and air, as well as the paint solvent carried by the second coat, may cause a hardening of the lower layers that diminishes oxygen diffusion. Thus, the response of the lower layers becomes

pressure-insensitive, and this decreases the sensitivity of the replenished coating as a whole. This phenomenon is more severe when the coating is illuminated from the back, rather than the front, because the part of the coating closest to the UV source absorbs the most photons, and so is the most strongly excited. In the back-illuminated case, it is precisely this part of the coating which is the least sensitive to pressure changes. In order to avoid the loss of sensitivity which accompanies replenishing, the sensor surface of the LPS system was changed each flight. Since the sensor surface was simply an inexpensive plexiglas panel, this procedure was feasible.

3.0 Flight Test Procedures

Table 1. Summary of flight test points.

Flight	Mach	Altitude (ft)	Type of Point
# 1329 5-31-91 (morning)	1.4	30,000	SL*
	1.3	30,000	SL
	1.2	30,000	SL
	1.2	30,000	SL
	1.1	30,000	SL
# 1331 6-19-91 (night)	1.6	30,000	SL
	1.5	30,000	SL
	1.4	30,000	SL
	1.3	30,000	SL
	1.2	30,000	SL
	1.1	30,000	SL
# 1334 7-2-91 (night)	1.5	33,000	SL&RD†
	1.4	33,000	SL&RD
	1.3	33,000	SL&RD
	1.2	33,000	SL&RD
	1.1	33,000	SL&RD

*(Straight & Level)

†(Rudder Doublet)

Data were acquired with the LPS on three separate flights of the F-104 aircraft. The first flight was conducted during the early morning, while the second two flights were at night. The flight test procedure was as follows: The LPS was first checked out on the ground to ensure proper operation, and a reference image was recorded. The LPS was then turned off, to keep exposure (and thus degradation) of the surface coating to a minimum as the aircraft taxied to the runway threshold. Just prior to takeoff, the system was reactivated, and data was recorded as the aircraft climbed to altitude and performed the test maneuvers. Typically the test run was complete within 30 min after takeoff. Once the test points had been obtained,

the system was turned off and the aircraft landed. On the first flight, the aircraft was released to another experiment after the test points were flown.

The flight test points consisted of straight and level flight (and, on the third flight, rudder doublets*) at Mach numbers between 1.0 and 1.6 and altitudes between 30,000 and 33,000 ft. The test points are summarized in table 1.

Video data were recorded with an onboard videotape machine, as well as being telemetered to two separate ground stations. Telemetered video data was acquired only to serve as a backup in case the onboard videotape machine failed. Due to transmission noise, the telemetered video was of poorer quality than the onboard video. An IRIG time code signal was recorded on the soundtrack of all three videotapes. This signal was later decoded and re-recorded on top of the original video signal, adding a time display to the video image. Using this time display for synchronization, the LPS data could be compared with data obtained at the same time from the air data system and conventional pressure sensors.

4.0 Results

No useful data was obtained from the first flight (#1329). The early morning ambient light level proved to be about four times as bright as the light emitted by the coated surface (as determined on later flights), completely washing out any paint signal.

Good video data was obtained on the two following flights, which allowed an assessment of the LPS system to be made. At the ground reference point and at each flight test point, 100 frames of video data were frame-averaged to reduce the effects of electronic noise in the camera and video recording system. A "dark noise" image was also obtained by operating the camera with its iris fully closed. The camera dark noise level was only 1-2 grey levels, which had a negligible impact on the dynamic range of the camera. The dark noise image was subtracted from both the reference and test point images, after which the reference image was divided by the test point image. At each pixel location, the intensity ratio thus obtained was linearly proportional to the ratio between the test point pressure and the reference, or ground level, pressure.

A typical intensity ratio image is shown in figure 10, for the $M = 1.6$ test point of flight #1331. The figure shows a view of the luminescent sensor window, surrounded by its aluminum frame. The window is primarily seen reflected off the 45° mirror — the actual window can be seen in an oblique view at the top of the figure. The airflow is from top to bottom, and the left side of the image is downward (toward the ground). The image has been false-colored to make details more apparent. Blue represents regions of relatively high pressure while red indicates relatively low pressure. The view of the center of the window is partially masked by the row of pressure taps and its associated tubing. The holes cut in the plexiglas for the pressure taps reflect light, creating a bright spot at the location of each tap. Conversely, the pressure tap tubing shades part of the window from the UV illumination, creating a visible line which runs just to the right of the pressure taps. Some flow features can be discerned in the image. The increase in pressure occurring in the downstream third of the window is believed

* In this maneuver, the rudder is deflected in first one direction and then the other, resulting in a brief oscillation of the side-slip angle, β .

to be due to the wing leading-edge shock impinging on the FTF. The pressure increase at the center downstream edge of the window can be attributed to the bow shock from the cylinder mounted just downstream of the window.

As mentioned above, the brightness of the current pressure-sensitive paint varies with temperature, and is subject to degradation from continued exposure to UV light. Since the window is illuminated for 15-20 min between the reference and test exposures, and since these exposures take place at widely differing temperatures, it is not possible to make an *a priori* calculation of the pressure distribution on the window. However, an *in situ* calibration of the LPS can be made by comparing the intensity ratio data with the data obtained from the pressure taps. This is done by examining the intensity ratio data along a line parallel to the row of pressure taps, and as close as possible to them. Since the intensity ratio and pressure data are linearly related, the calibration coefficients can be easily calculated with a linear least-squares fit. *In situ* calibration factors out the effects of overall temperature variation, degradation of the coating, and the camera variations discussed in section 2.3. If the pressure tap data is assumed to be true, the error of the least-squares fit can be considered to give the accuracy of the pressure measurements obtained with the luminescent paint. Since the surface temperature will vary with Mach number, a separate *in situ* calibration must be done for each test point.

Figure 11 shows the results of such a calculation for the image shown in figure 10 (Flight #1331 at $M = 1.6$). The figure shows good agreement between the pressure tap data (open squares) and the luminescent paint data (solid line). The rms error of the fit at this condition is 41 psf, due mostly to the failure of the luminescent paint to capture the pressure levels at the sixth and ninth pressure taps. It is possible that this difference is due to an actual change in pressure between the tap location and the location at which the line of intensity ratio data was obtained. However, this cannot be verified due to the interference of the pressure tubing with the image at the tap locations.

The comparison between pressure tap and luminescent paint data described above was performed for all test points, in order to make an overall evaluation of the coating's accuracy. The rms error of the fit for each test point is shown in figure 12. As this figure shows, the agreement between paint and pressure tap data is relatively good at higher Mach numbers, but deteriorates as Mach number decreases. The trends are similar for both test flights, and for both the straight & level and rudder doublet points in flight #1334. This strongly suggests that the variation in accuracy of the paint results is due to the variation in flight conditions, rather than any change in the instrumentation or paint behavior. Another view of the problem can be observed in figure 13, in which the pressure results from the paint are plotted against those for the pressure taps at different Mach numbers. It is clear that below $M = 1.3$, the paint is unable to capture even the qualitative trends of the pressure variation. The most likely explanation for this failure is the appearance of a temperature gradient across the surface at the lower Mach numbers. A gradient of roughly 5°C per in. over the downstream half of the sensor surface would account for the observed error in the intensity ratio data.

Within the region where there do not appear to be substantial temperature gradients ($M = 1.4$ and higher), intensity ratio and pressure tap data typically agree to within 35 psf over a range of 400 psf. The *precision* of the LPS measurements, defined as the smallest detectable

pressure variation, is roughly 20 psf under these conditions. This compares favorably with a precision of 15 psf which is obtainable in wind tunnel studies.

5.0 Conclusions

The test results show that a Luminescent Pressure Sensor system can obtain quantitative data under flight conditions. Pressure measurements accurate to within ± 35 psf can be made over a relatively large area (compared to conventional pressure taps), and gross features of the pressure distribution can be discerned. The measurement precision of 20 psf indicates that it should be possible to improve accuracy by a factor of two with an improved signal to noise ratio and better correction for temperature effects. The present results were obtained with a system in which the camera and illuminating lamp were mounted internal to the test surface. As stated above, this system was adopted to simplify the test and to allow measurements under high ambient light levels. There is no reason to believe that the results of the present test will not be applicable to an external system, wherein a lamp and camera mounted on one part of the test aircraft are used to view a region of interest on another part of the aircraft.

Nonetheless, the present test has shown some important limitations of the Luminescent Pressure Sensor in the flight environment. These are listed below:

(1) Sensitivity to ambient light. Light from sources other than the paint itself is picked up as noise. The internal system used in the current test was constructed so as to illuminate the test surface as brightly as possible. This system was unable to cope with even near-optimum daylight conditions (e.g., early morning light). The only effective way to remove the noise generated by ambient light is to remove the light itself, by flying tests at night. Moonlight* and starlight are not sufficiently intense to interfere with the LPS. Noise generated by aircraft strobe lights occurs only at brief, well-defined periods, and thus can be easily filtered out.

(2) In situ calibration. Whenever the UV illumination is on, the paint degrades at a rate dependent upon the local temperature and UV intensity. In addition, temperature affects the paint's response to pressure variations directly. These effects make it impractical to calibrate the paint based on an *a priori* knowledge of its characteristics. Instead, the LPS must be calibrated *in situ*, using conventional pressure taps on the test surface. The number of taps required for calibration, however, is far less than would be needed to get an accurate picture of the pressure distribution, if pressure taps alone were used.

(3) Limited sensitivity. Luminescent paint-derived pressures at any given point are less precise than those obtained with conventional pressure transducers. This is due both to the sensitivity of the paint itself (the change in brightness for a given change in pressure) and the ability of the video system to resolve small changes in brightness. Research is underway to develop more sensitive paint formulations, as well as to adapt more sensitive video systems for LPS use.

(4) Design of LPS equipment. The current study has generated a base of expertise in the design of LPS systems for flight use. Some points in particular are worth noting. The low-contrast images generated by the LPS system require that a high signal-to-noise ratio be

* Flight #1331 was made seven days before the full moon, and flight #1334 was made six days after the full moon. At no time was the camera staring directly at the moon.

maintained in all parts of the aircraft video system, from the camera to the video recorder. (The current results show that onboard video recorders are preferable to video downlinks for this reason.) The UV illumination system, on the other hand, tends to be a brute force device which requires relatively large amounts of power, and, during the ignition cycle, operates at high voltage. While these technical issues are by no means unusual, they must be recognized and dealt with in order to construct a successful system.

The comments above are specifically directed toward the use of luminescent pressure sensor systems in flight tests. It must be borne in mind that these systems also suffer the general limitations discussed in section 1.0, namely temperature sensitivity, relatively low dynamic range, and long time response. To a very large extent, these limitations reflect the immature state of luminescent pressure sensor technology. Current research efforts are developing paints with superior sensitivity, degradation resistance, and time response, as well as combined pressure/temperature sensitive paints, which will eliminate the temperature sensitivity problem. Once confidence in these new coatings is gained through benchtop and wind tunnel tests, they will significantly expand the usefulness of pressure sensitive paints in flight tests.

The logical next step in luminescent paint flight tests is the use of the paint to obtain scientifically interesting information. Candidate experiments should be carefully considered in view of the limitations discussed above. A suitable experiment would be one in which it is desirable to get mean pressure data over a large area. The temperature gradient across the surface must be known or negligible, or a combined pressure/temperature coating must be used. The test surface must be instrumented with at least a few conventional pressure taps to facilitate *in situ* calibration, and a similar number of surface temperature sensors would also be highly desirable. The aircraft geometry must be such that the camera and UV lamp can be mounted with a good viewing angle, i.e., within about 60° of the perpendicular to the test surface. The aircraft must have onboard videorecording capability, and must be wired for data transfer at video rates (10 MHz). Finally, in order to eliminate noise from external light sources, it must be possible to fly at night. Given these provisos, luminescent paint should be able to provide a unique source of surface pressure data for a flight test program.

REFERENCES

Kavandi, J. L.: Luminescence Imaging for Aerodynamic Pressure Measurements. Doctoral Thesis, Chemistry Dept., University of Washington, Seattle, Washington, 1990.

Kavandi, J.; Callis, J.; Gouterman, M.; Khalil, G.; Wright, D.; Green, E.; Burns, D.; and McLachlan, B.: Luminescent Barometry in Wind Tunnels. *Rev. Sci. Instruments*, vol. 61, no. 5, November 1990, pp. 3340-3347. (Paper #1 in a series on Luminescent Aerodynamic Imaging.)

Meyer, R. R.: A Unique Flight Test Facility: Description and Results. NASA TM-84900, 1982.

McLachlan, B. G.; Kavandi, J. L.; Callis, J. B.; Gouterman, M.; Green, D.; Khalil, G.; Burns, D.: Surface Pressure Field Mapping Using Luminescent Coatings. To be published in *Experiments in Fluids*, 1992. (Paper #2 in a series on Luminescent Aerodynamic Imaging.)

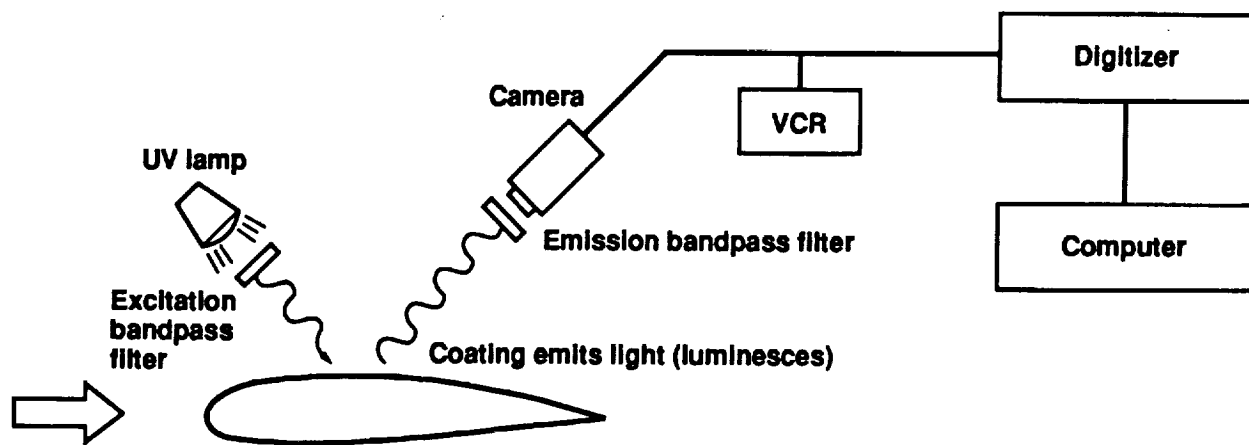

- Luminescence intensity depends on oxygen partial pressure
- Mole fraction of oxygen in air is known
- Video/photo + image processing to measure intensity, thus mapping surface pressure
- Complementary excitation and emission filters

Figure 1. Functional schematic showing Luminescent Pressure Sensor laboratory setup.

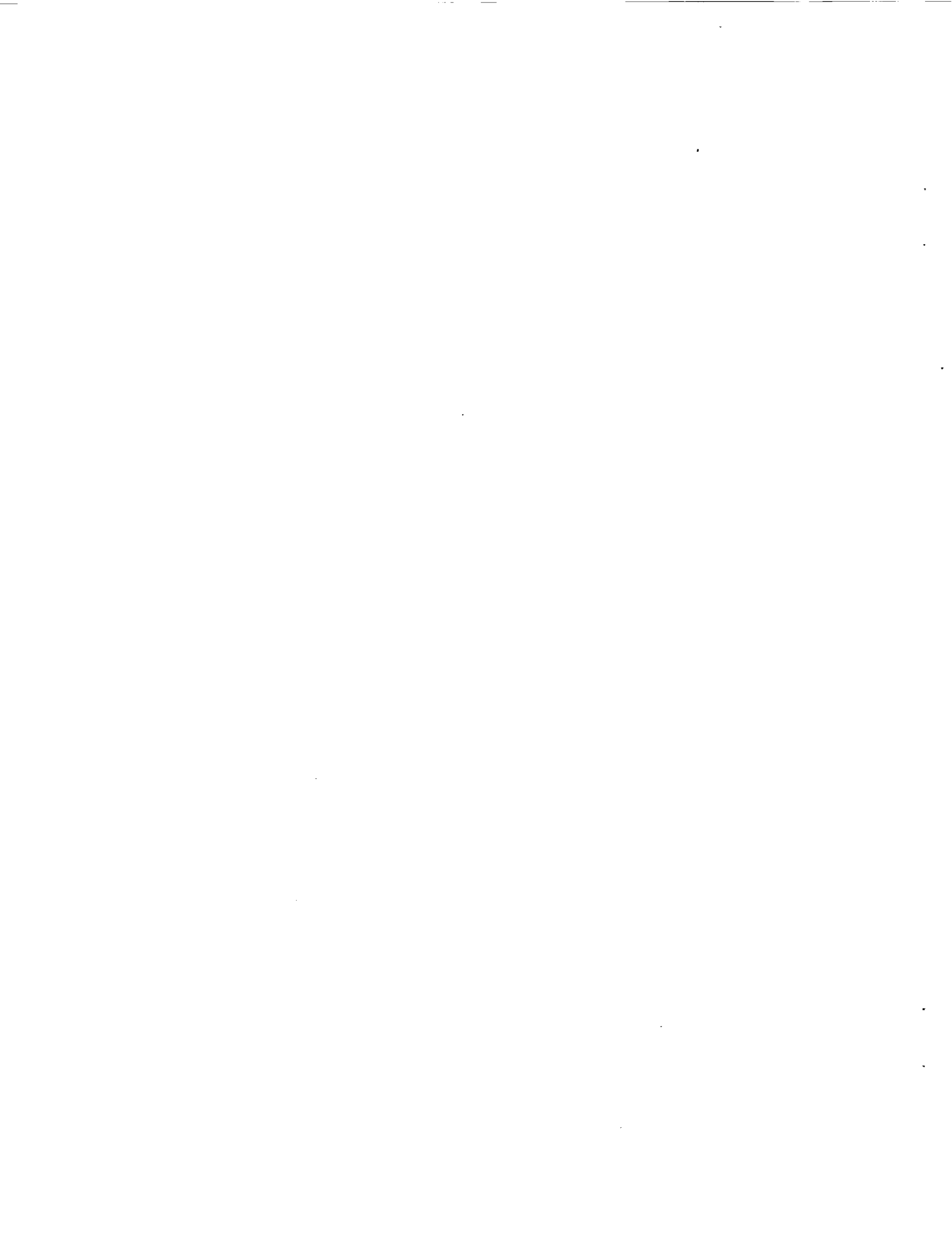



Figure 2. Composite photo of F-104G aircraft configured with Flight Test Fixture. Lower portion of figure shows FTF with covers off, displaying painted test surface, pressure transducers, and UV lamp power supply.

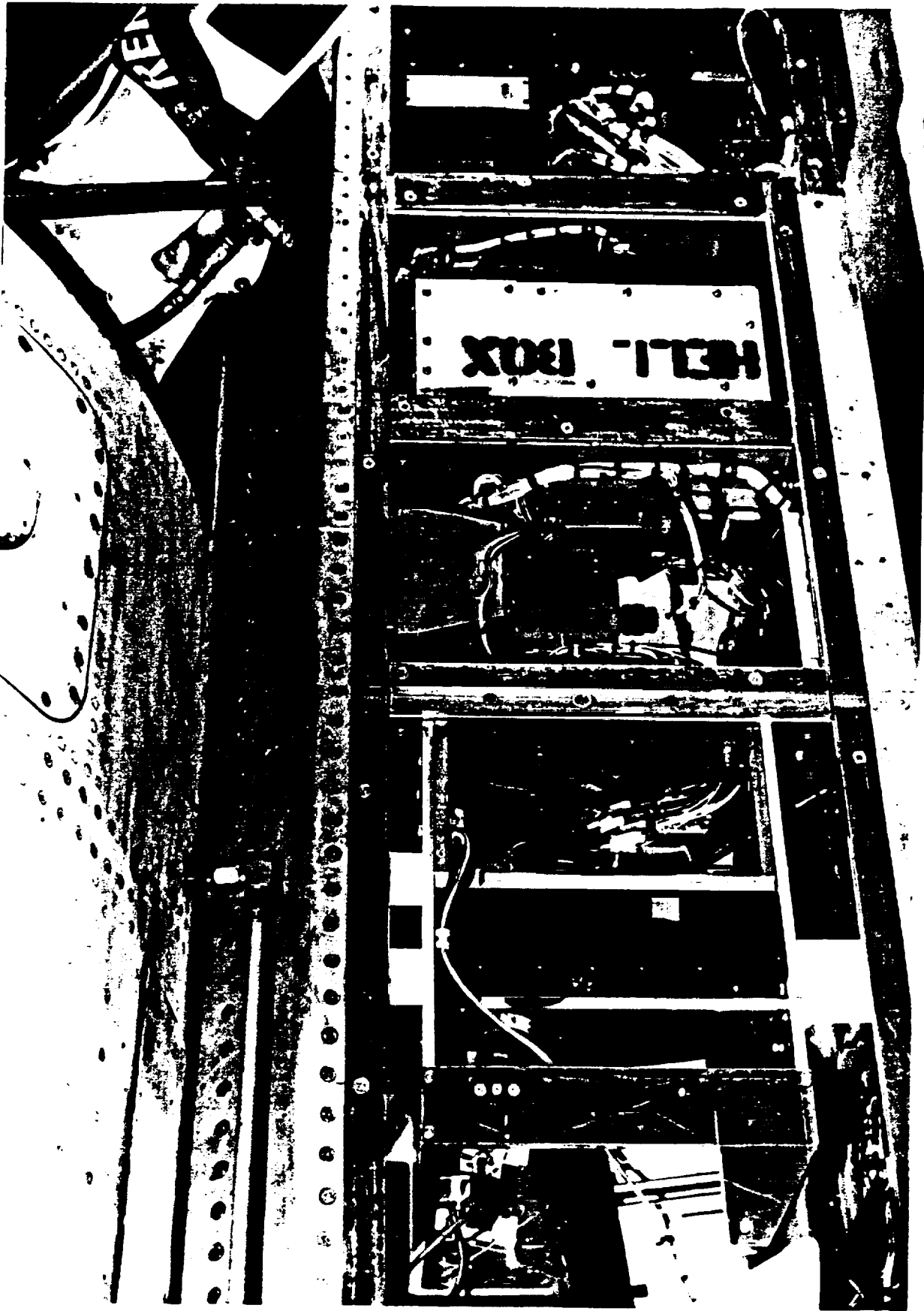

Figure 3. Photo showing opposite side of FTF. Labeled box is lamp power supply. Luminescent Pressure Sensor system is mounted in leftmost bay.

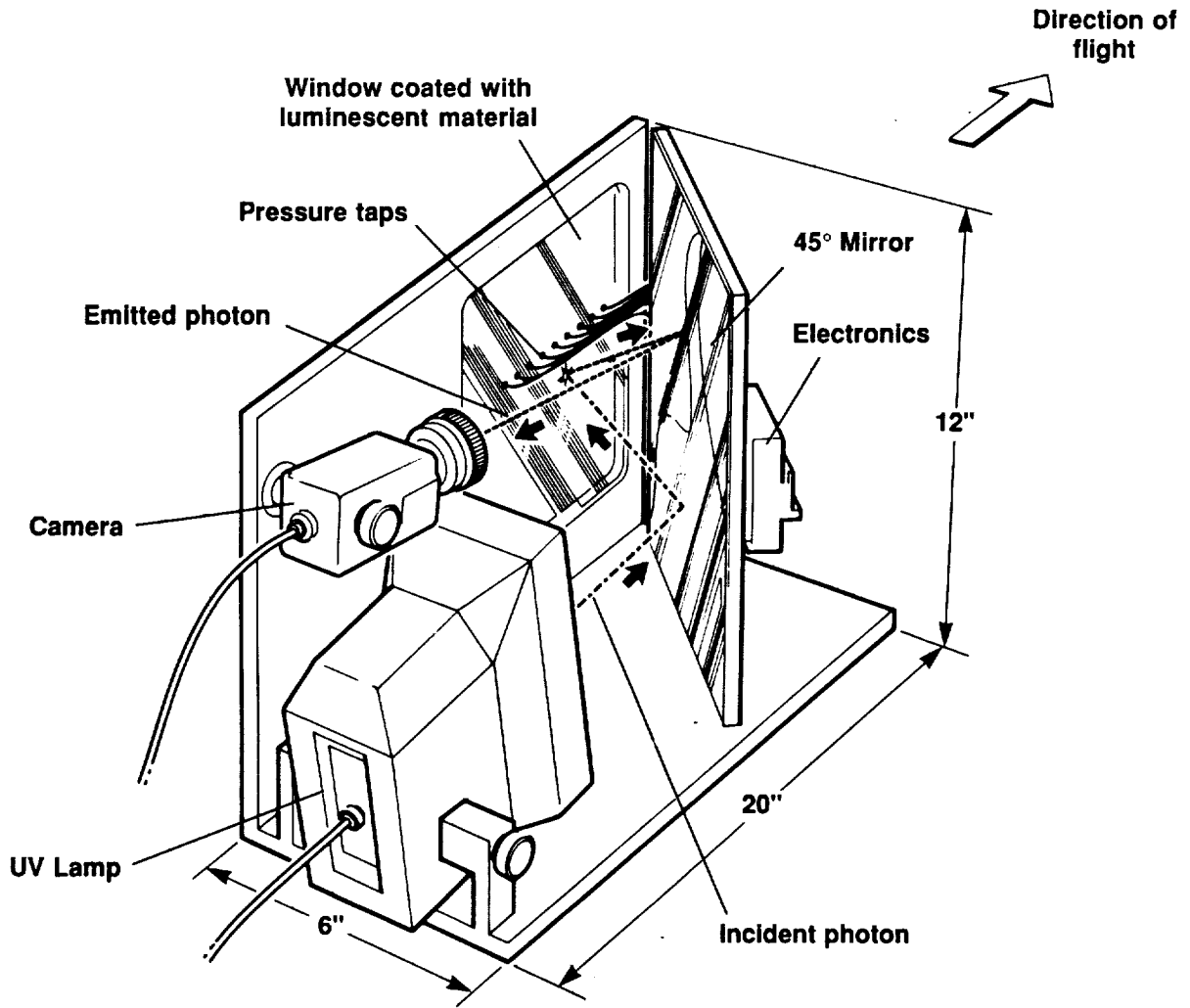
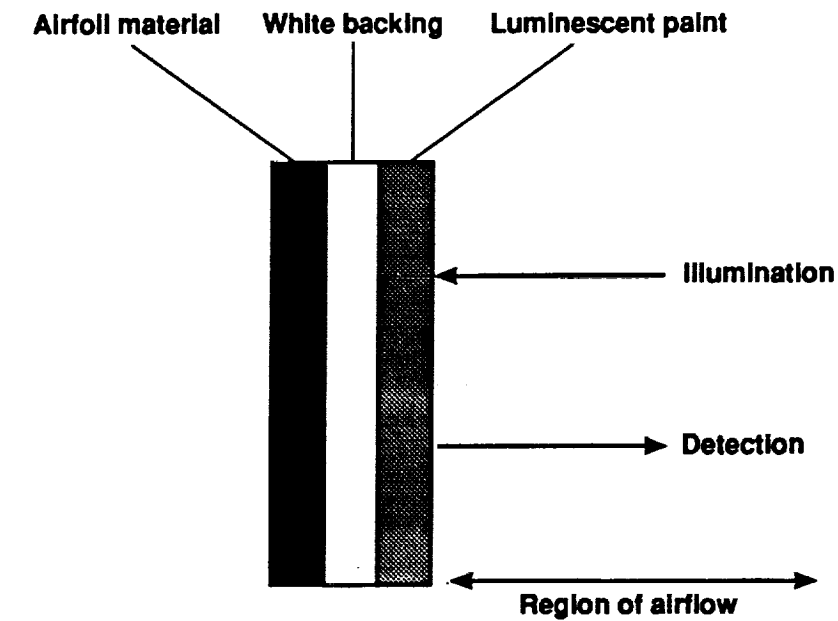
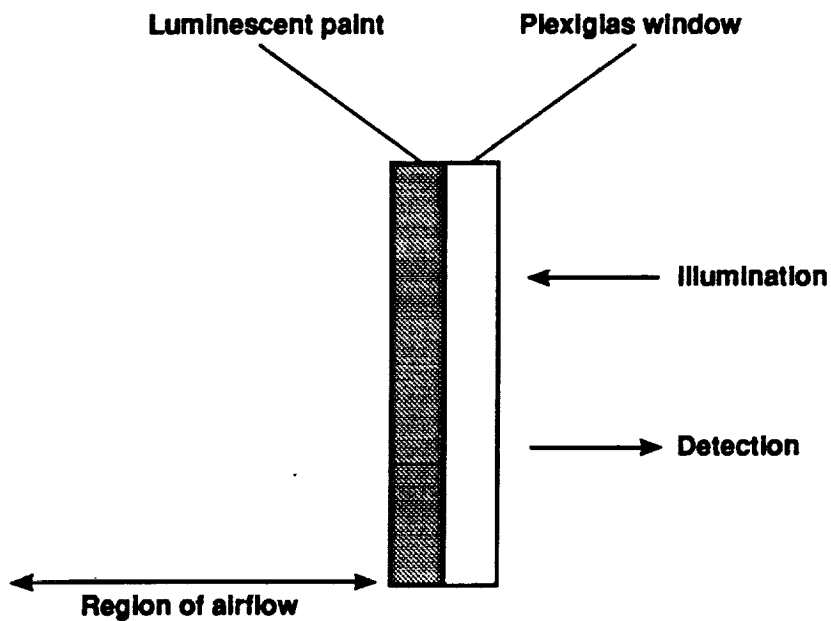

Figure 4. Line drawing of Luminescent Pressure Sensor system, showing paths taken by an incident (UV) photon and the corresponding red photon emitted when the UV photon strikes the painted surface.



(a) Wind tunnel geometry



(b) Flight test geometry

Figure 5. Comparison of the experimental geometry in the wind tunnel (a), and the flight test (b). Illumination and detection are from the same side as the flow in the wind tunnel geometry while on the opposite side in the flight test geometry.

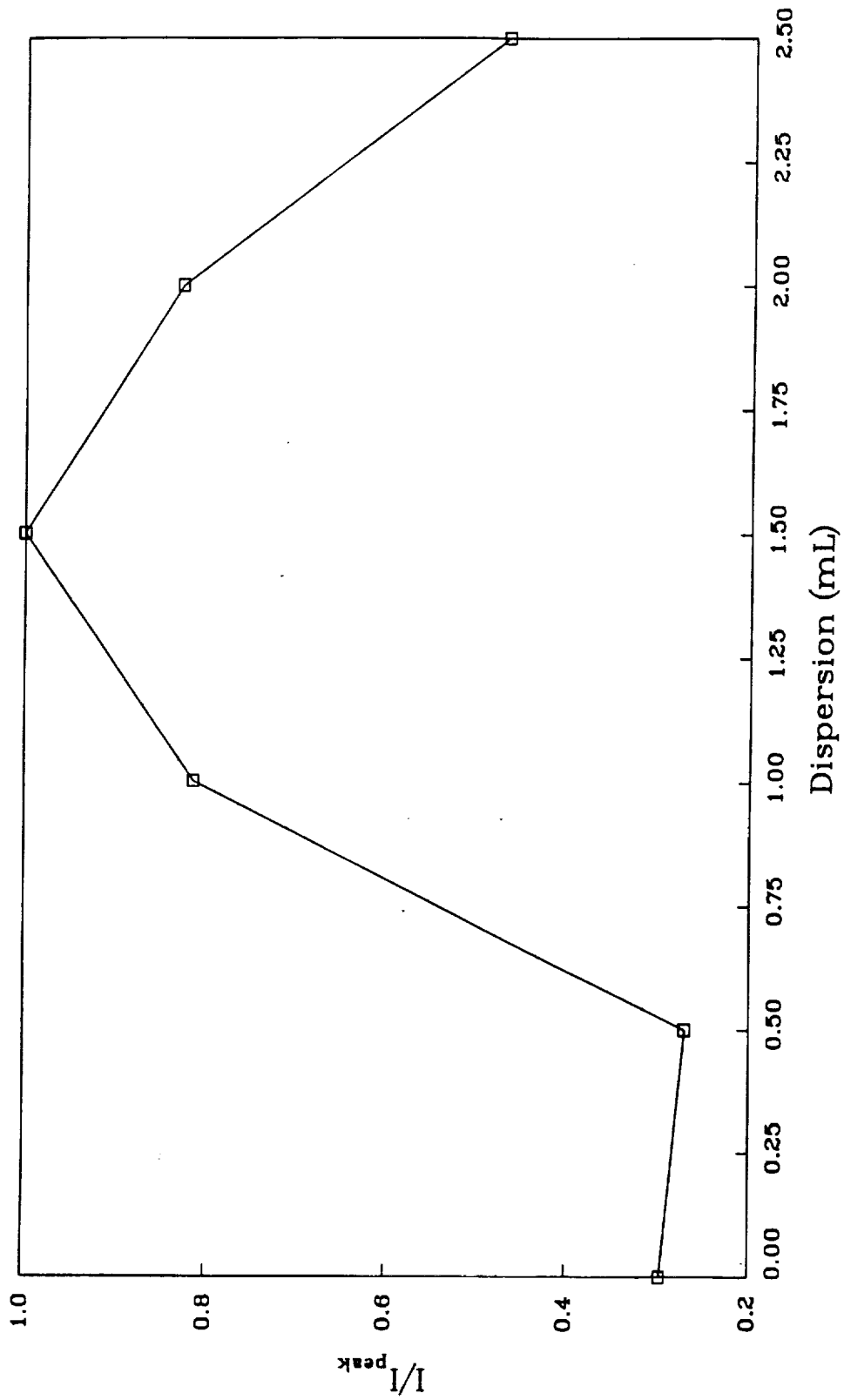

Figure 6. Variation in luminescent paint signal strength with the addition of a scattering agent.

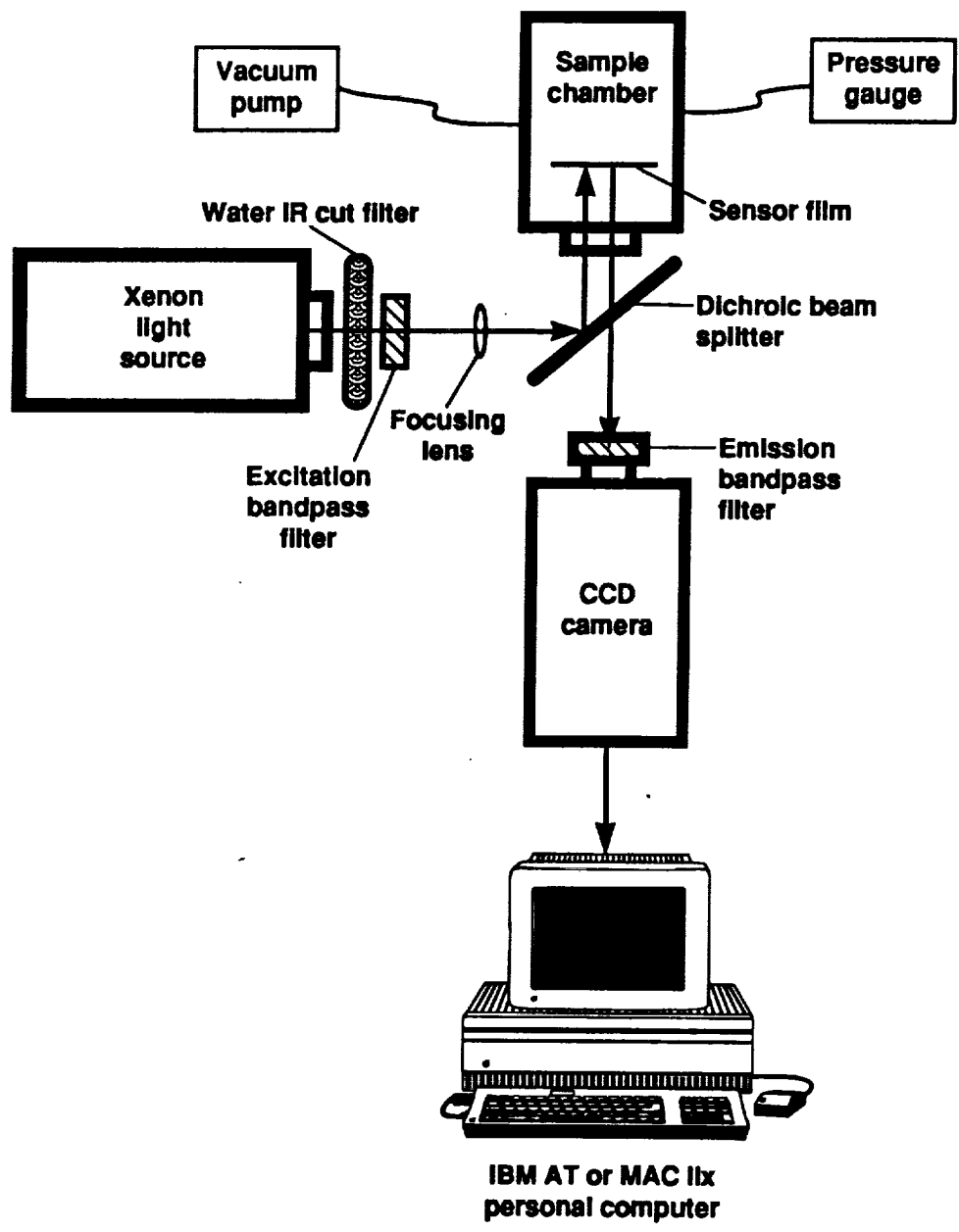

Figure 7. Schematic of static calibration unit.

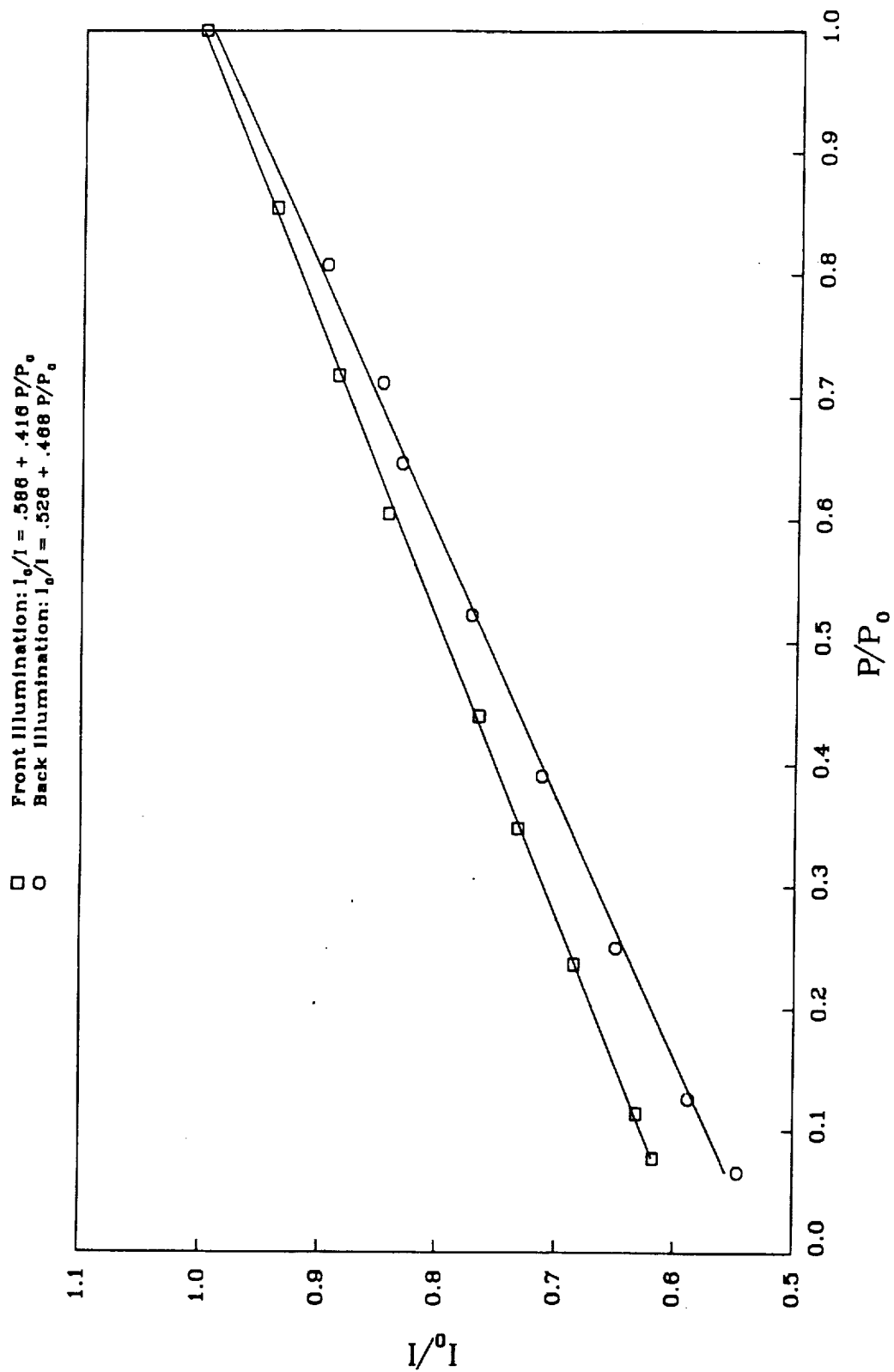

Figure 8. Calibration curves for front- and back-illuminated geometries of luminescent paint.

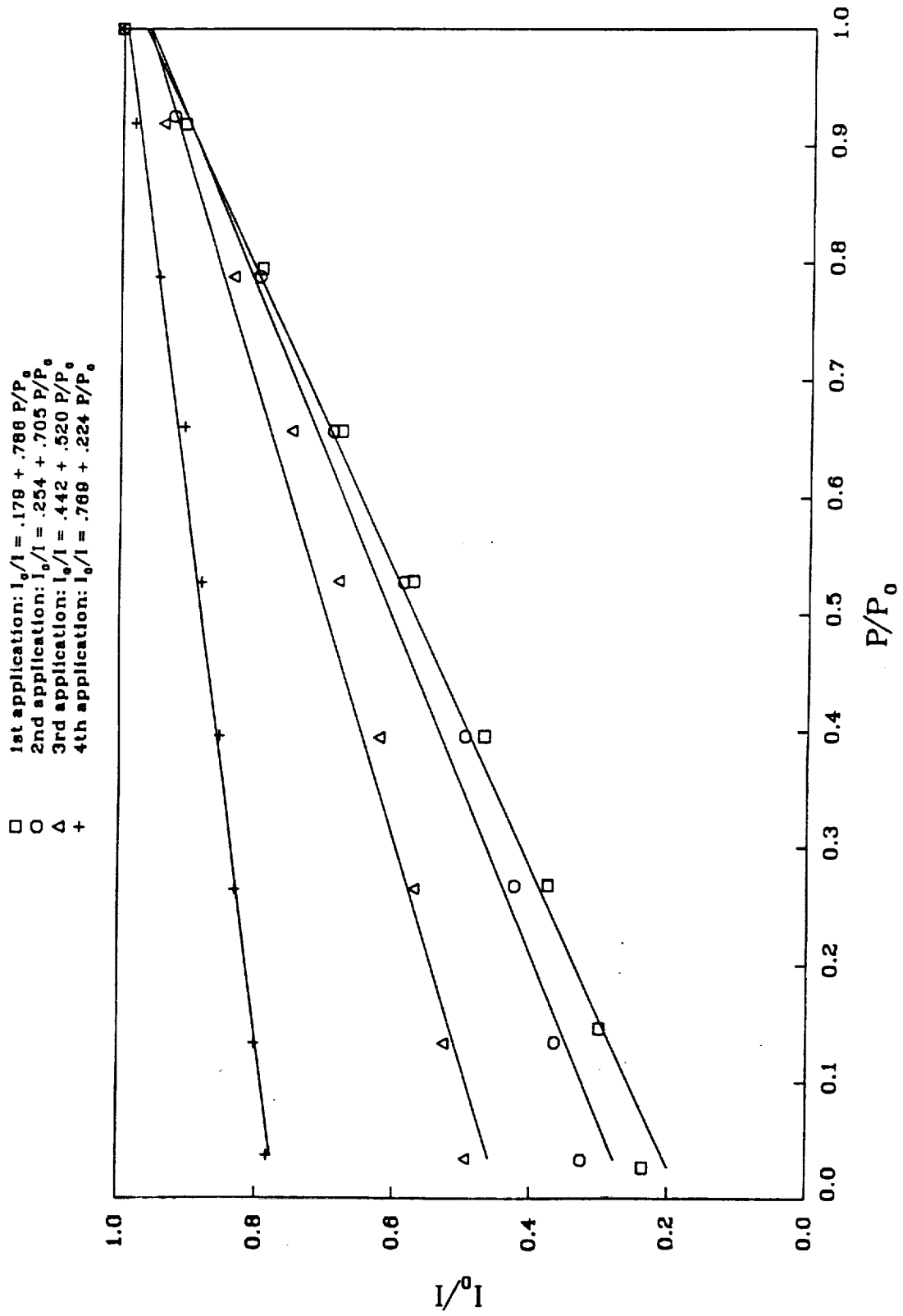

Figure 9. Effect of continued replenishing on luminescent paint sensitivity.

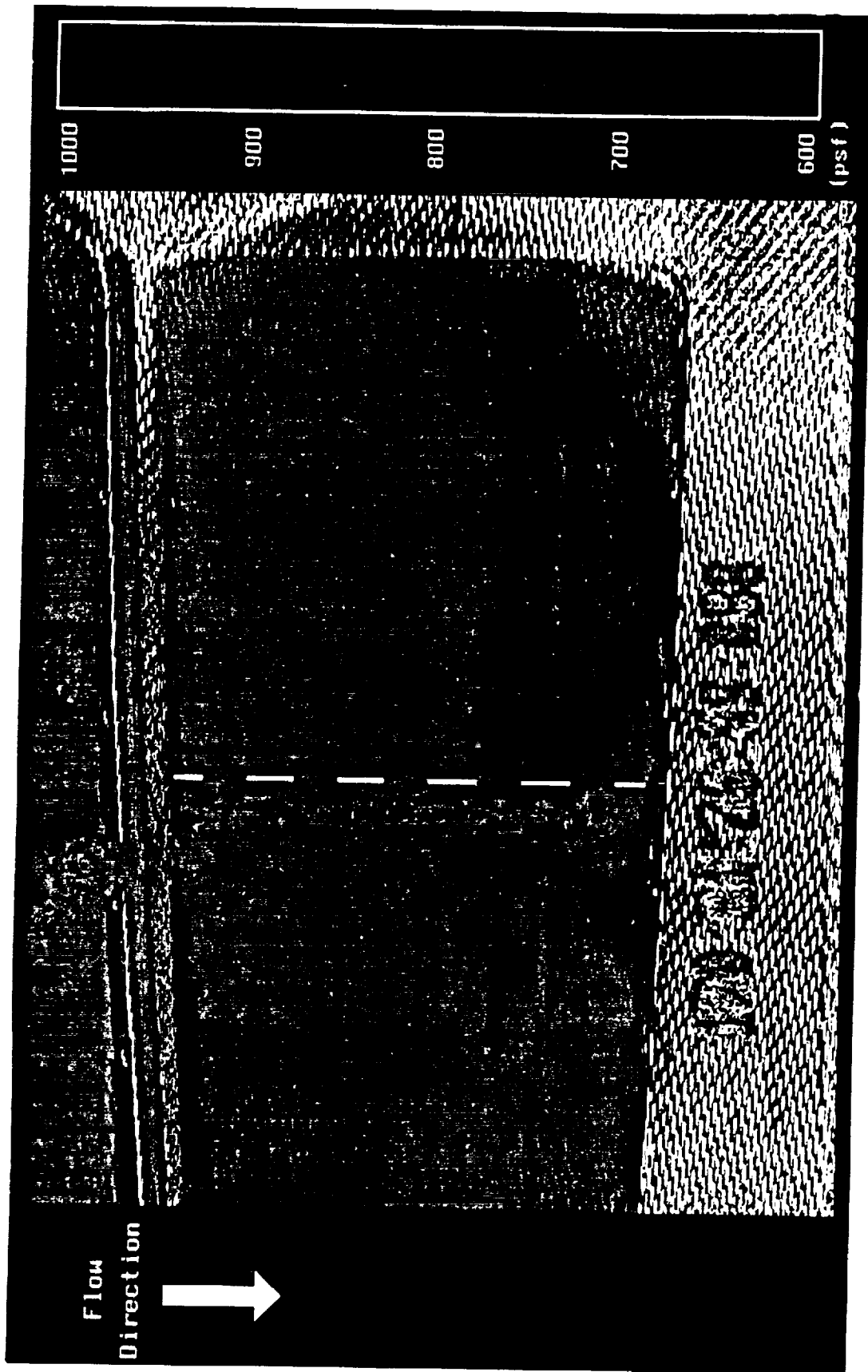

Figure 10. False colored luminescent paint image of pressure on sensor surface. Data is from the $M = 1.6$ test point of flight #1331. Dotted line indicates where data was taken for comparison with pressure taps.

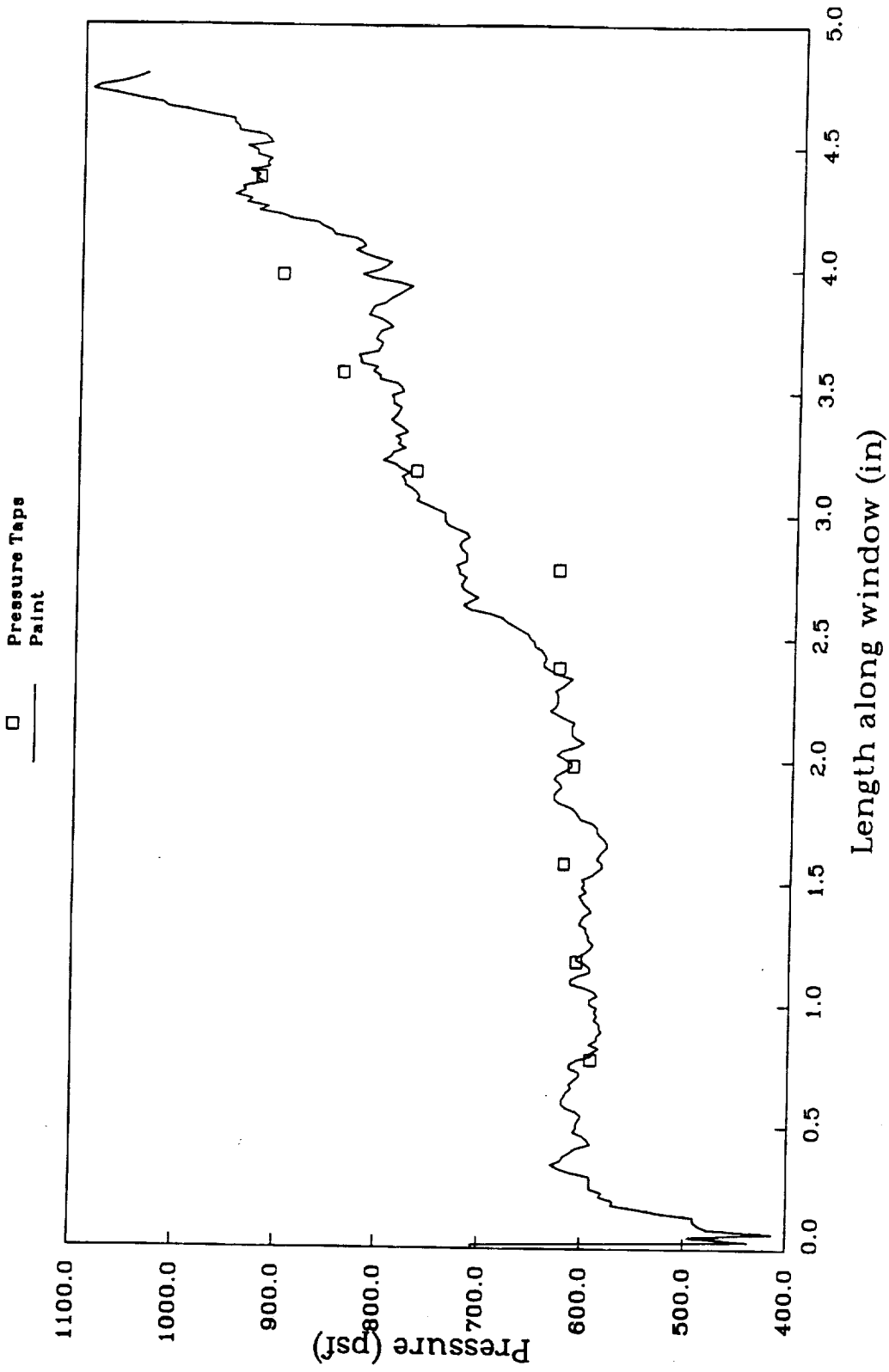

Figure 11. Comparison of pressures derived from luminescent paint with those obtained from conventional pressure taps. Data is from the M = 1.6 test point of flight #1331.

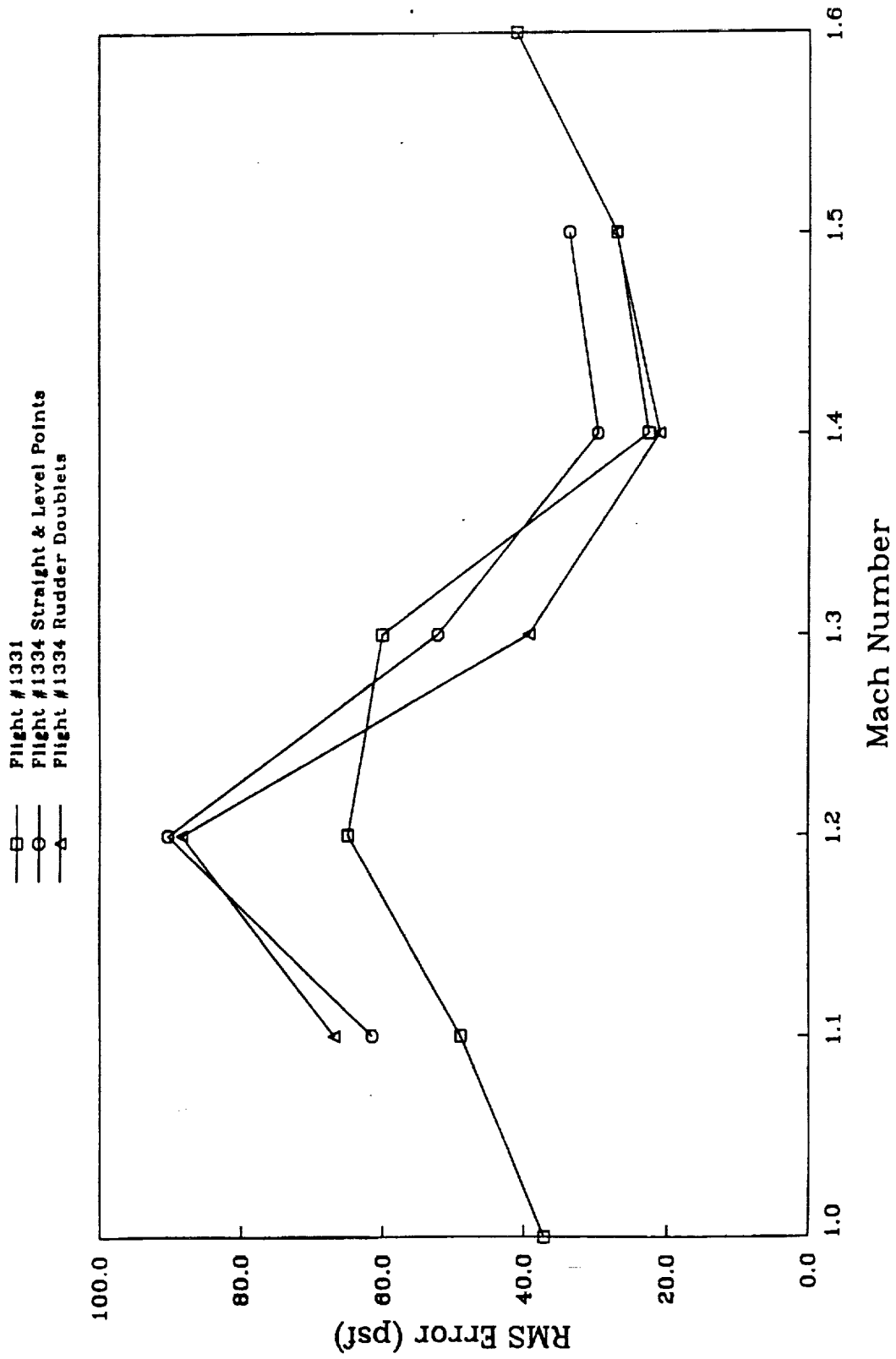

Figure 12. RMS error of fit at each test point.

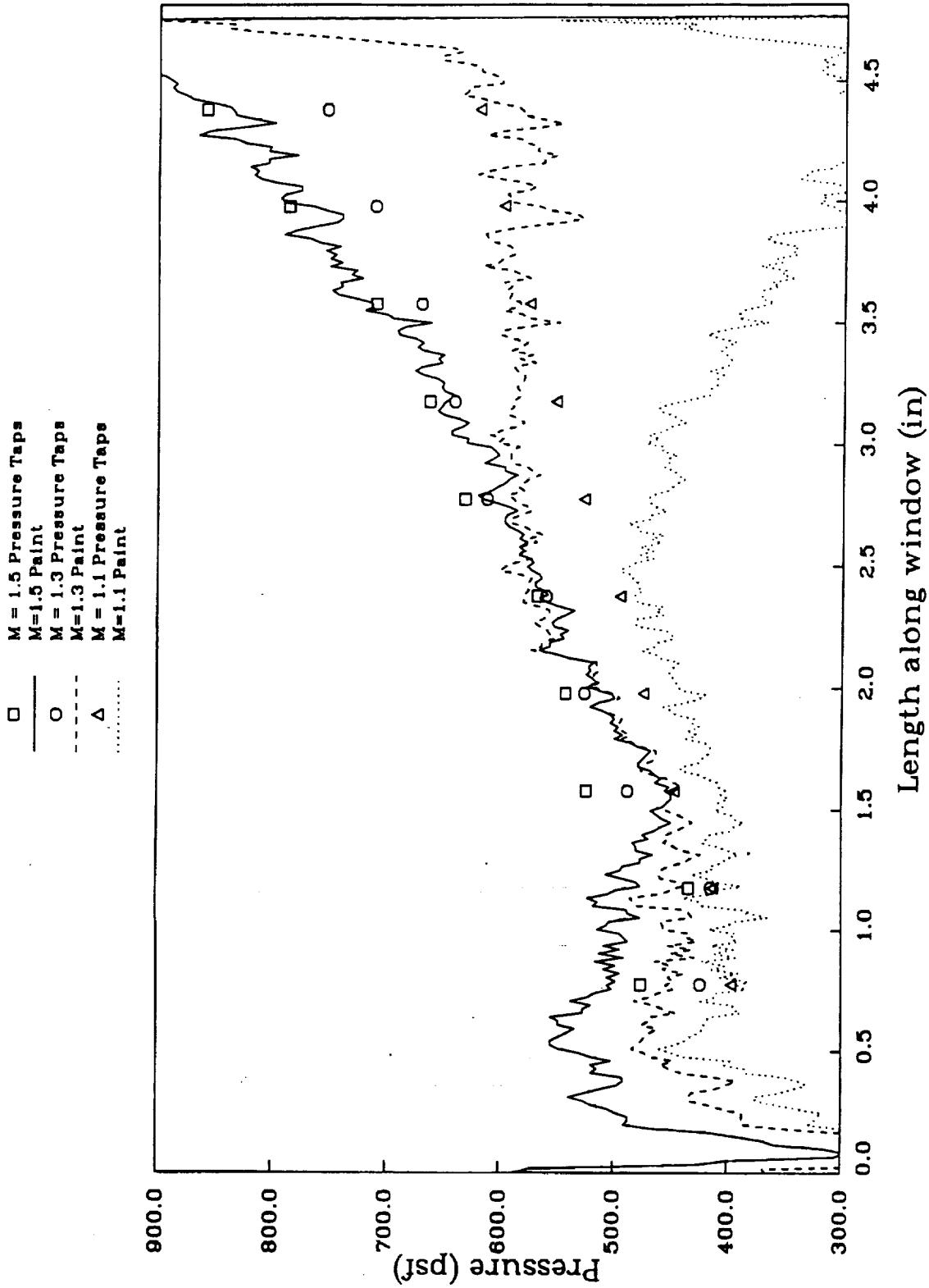

Figure 13. Comparison of pressures derived from luminescent paint with those obtained from conventional pressure taps. Data is from all straight and level test points of flight #1334. The results show the decreasing accuracy of the paint data at lower mach numbers.

REPORT DOCUMENTATION PAGE

Form Approved
OMB No. 0704-0188

Public reporting burden for this collection of information is estimated to average 1 hour per response, including the time for reviewing instructions, searching existing data sources, gathering and maintaining the data needed, and completing and reviewing the collection of information. Send comments regarding this burden estimate or any other aspect of this collection of information, including suggestions for reducing this burden, to Washington Headquarters Services, Directorate for Information Operations and Reports, 1215 Jefferson Davis Highway, Suite 1204, Arlington, VA 22202-4302, and to the Office of Management and Budget, Paperwork Reduction Project (0704-0188), Washington, DC 20503.

1. AGENCY USE ONLY (Leave blank)		2. REPORT DATE October 1992	3. REPORT TYPE AND DATES COVERED Technical Memorandum	
4. TITLE AND SUBTITLE Flight Testing of a Luminescent Surface Pressure Sensor			5. FUNDING NUMBERS 537-03-23	
6. AUTHOR(S) B. G. McLachlan, J. H. Bell, J. Espina, J. Gallery,* M. Gouterman,* C. G. N. Demandante,* L. Bjarke**				
7. PERFORMING ORGANIZATION NAME(S) AND ADDRESS(ES) Ames Research Center Moffett Field, CA 94035-1000			8. PERFORMING ORGANIZATION REPORT NUMBER A-92175	
9. SPONSORING/MONITORING AGENCY NAME(S) AND ADDRESS(ES) National Aeronautics and Space Administration Washington, DC 20546-0001			10. SPONSORING/MONITORING AGENCY REPORT NUMBER NASA TM-103970	
11. SUPPLEMENTARY NOTES Point of Contact: B. G. McLachlan, Ames Research Center, MS 260-1, Moffett Field, CA 94035-1000; (415) 604-4142 *University of Washington, Seattle, WA 98195 **Dryden Flight Research Facility, Edwards, CA 93523-0273				
12a. DISTRIBUTION/AVAILABILITY STATEMENT Unclassified — Unlimited Subject Category 01			12b. DISTRIBUTION CODE	
13. ABSTRACT (Maximum 200 words) NASA Ames Research Center has conducted flight tests of a new type of aerodynamic pressure sensor based on a luminescent surface coating. Flights were conducted at the NASA Ames-Dryden Flight Research Facility. The luminescent pressure sensor is based on a surface coating which, when illuminated with ultraviolet light, emits visible light with an intensity dependent on the local air pressure on the surface. This technique makes it possible to obtain pressure data over the entire surface of an aircraft, as opposed to conventional instrumentation, which can only make measurements at pre-selected points. The objective of the flight tests was to evaluate the effectiveness and practicality of a luminescent pressure sensor in the actual flight environment. A luminescent pressure sensor was installed on a fin, the Flight Test Fixture (FTF), that is attached to the underside of an F-104 aircraft. The response of one particular surface coating was evaluated at low supersonic Mach numbers ($M = 1.0 - 1.6$) in order to provide an initial estimate of the sensor's capabilities. This memo describes the test approach, the techniques used, and the pressure sensor's behavior under flight conditions. A direct comparison between data provided by the luminescent pressure sensor and that produced by conventional pressure instrumentation shows that the luminescent sensor can provide quantitative data under flight conditions. However, the test results also show that the sensor has a number of limitations which must be addressed if this technique is to prove useful in the flight environment.				
14. SUBJECT TERMS Pressure sensitive paint, Pressure sensor, Flight testing			15. NUMBER OF PAGES 32	
			16. PRICE CODE A03	
17. SECURITY CLASSIFICATION OF REPORT Unclassified	18. SECURITY CLASSIFICATION OF THIS PAGE Unclassified	19. SECURITY CLASSIFICATION OF ABSTRACT	20. LIMITATION OF ABSTRACT	