

A Dynamic Method for Magnetic Torque Measurement

C. E. Lin H. L. Jou

Institute of Aeronautics and Astronautics
National Cheng Kung University
Tainan, Taiwan, China

SUMMARY

In a magnetic suspension system, accurate force measurement will result in better control performance in the test section, especially when a wider range of operation is required. Although many useful methods were developed to obtain the desired model, however, significant error is inevitable since the magnetic field distribution of the large-gap magnetic suspension system is extremely nonlinear. This paper proposed an easy approach to measure the magnetic torque of a magnetic suspension system using an angular photo encoder. Through the measurement of the velocity change data, the magnetic torque is converted. The proposed idea is described and implemented to obtain the desired data. It is useful to the calculation of a magnetic force in the magnetic suspension system.

INTRODUCTION

In a large-gap magnetic suspension system, an adequate magnetic force model determines the accuracy of force measurement within the test section, such as wind tunnel applications. Many useful methods have been developed to obtain the desired model. However, the magnetic field distribution of the large-gap magnetic suspension system results in significant model error. From the force model, the velocity change of the suspended model implicitly contains the force model. It is obvious that the applied force on the suspended model leads to more direct and accurate information to look into the force model, if the velocity data can be obtained.

From Newton's Second Motion Law, the magnitude of acceleration in motion refers to the applied force or torque to the object. This is also useful to motion objects in a magnetic field to measure magnetic force or torque. However, the measurement of acceleration is difficult using conventional methods. The results are obtained from a first or second derivative from the velocity or position data, respectively. It requires an extreme effort to identify measured data under noisy conditions.

The torque model to describe the magnet suspending in the space magnetic field is expressed by:

$$\vec{T} = \int_v \vec{M} \times \vec{B} dv. \quad (1)$$

Assume the magnet is very small comparing relatively in the magnetic field space to cause little influence. Then the force model equation is approximated into:

$$\vec{T} = vol(\vec{M} \times \vec{B}) \quad (2)$$

[1]. This equation does not contain an integration, and is very simple in real time calculation. However, errors may exist.

Since the proposed method uses the dynamic measurement method to obtain the force model data, the results are free from the influence of magnetic field distribution. The proposed dynamic measurement method is applied to calibrate the approximate force model.

In this paper, the experimental setup is presented with test procedures based on the proposed measurement concept. A real time data acquisition system for position data measurement from an angular photo encoder with a data processing personal computer is established for the experiments. The obtained torque model is used in a large-gap magnetic suspension system.

TORQUE MEASUREMENT

Figure 1 shows the experimental setup of this study. A permanent magnet is fixed to become a single pendulum. The pendulum is attached to an angular photo encoder. The angular position change data are measured from the encoder, and are transmitted to PC-AT via an interface I/O card. The angular change data are real time acquired and displayed on the monitor. The pendulum with

magnet is located on the top of a circular electromagnetic axis. When the electromagnet is energized or excited, the magnetic force exerting on the permanent magnet will be measured from the locus of the pendulum. During the measurement process, the exerting force on the magnet includes the magnetic force and gravitation force. The former is desired, while the latter should be eliminated. Considering the damping condition, the equation of motion is expressed:

$$\ddot{\theta} = \frac{mgl}{I} \sin\theta + b\dot{\theta}, \quad (3)$$

where $I = 0.0005165 \text{ Kg} \cdot \text{m}^2$, $m = 0.033 \text{ Kg}$, $l = 0.115 \text{ m}$. Assume $b = 0.5$; solve the above equation to obtain the angular position and velocity. In Figure 2, a computational result expressed in a solid line and the experimental result expressed in a dashed line are shown with good agreement.

From the results, the resulting data through two differencing processes of the measurement data from an angular photo encoder contain some acceptable noise. Because the sampling rate in this test is 100 Hz to match the low angular change rate, the error resulting from difference amplification is still tolerable. When testing a higher speed angular change rate, a higher sampling rate may be required to result in noisy conditions. The noise and signal may combine together.

BÊZIER B-SPLINE CURVE FITTING

Taking care of the problem of difference amplification of the noise, a curve fitting method to smooth the obtained data is applied before signal differencing, in order that continuity be maintained after the differencing process. The algorithm is termed as *Bézier B-spline* curve fitting [2]. The advantage of B-spline curve fitting is to fit a possible inclination of the data curve, instead of including all the control points. The B-spline curve method is not so sensitive as to change the rate in comparison to the cubic spline method, is simpler by calculation in comparison to the iteration algorithms, results in a much closer curve to all changes, and is free from the limitation of control points comparing to the Bezier curve fitting. If there are more than 10 control points, the Bezier curve fitting will become very high order, making it difficult to calculate.

Before applying curve fitting, all the ill data points, such as data jumps, should be filtered. If the control points fall on the ill data, a great fitting error may result. The number of control points also determines the change rate of the fitting curve. The more control points

that are included, the faster the fitted curve change rate might be obtained. It is a trade-off consideration to determine the control points, curve change rate, and possible oscillation after differencing processes.

MAGNETIC TORQUE MEASUREMENT AND CALCULATION

Figure 3 shows the process of measurement of acceleration to obtain magnetic torque. Fig. 3(a) shows the measured angular change; Fig. 3(b) shows the obtained angular velocity by the difference of angular change in a solid line, and by the Bizier B-spline curve fitting in a dashed line; Fig. 3(c) shows the angular acceleration after the linear difference from the fitted angular velocity of the above dashed line and the result subtracted from the gravity effect in the solid line and dashed line; Fig. 3(d) shows the magnetic torque by multiplying the angular acceleration and the inertia moment with respect to the angular data.

Figure 4(a) shows a magnetic field measurement in a pendulum locus; the solid line shows the axial magnetic field data, while the dashed line shows the radial magnetic field data. According to the magnetic torque equation,

$$\vec{T} = vol(\vec{M} \times \vec{B}), \quad (4)$$

to calculate the magnetic torque as shown in Fig. 4(b), where \vec{M} is the magnetization vector of the permanent magnet, and B is the space magnetic flux density obtaining from Fig. 4(a). Comparing the theoretical result in Fig. 4(b) and the experimental result in Fig. 3(d), the difference is significant by about 3 times.

DISCUSSIONS

From the measurement results, the theoretical results and the experimental results of the magnetic torque distribution are shown in Figures 3 and 4 for comparison. The differences between those two results are significant as compared with about 3 times difference. Because of the many calibrations and recalculations, the differences in the results are difficult to see. At present, we are still working on the identification of the proper explanation of the obtained results. More detailed discussions will be presented in the revised paper which will be included in the conference proceedings.

ACKNOWLEDGEMENT

This work is supported by National Science Council, Taiwan, ROC, under contract number NSC81-0424-E005-040.

REFERENCES

1. Groom, N.J.: *Analytical Model of a Five Degree-of-Freedom Magnetic Suspension and Positioning system*. NASA TM-100671, March 1989.
2. D. Kahaner, Cleve Moler, Stephen Nash, *Numerical Methods and Software*, Prentice-Hall Inc, New York, 1989, pp. 132.

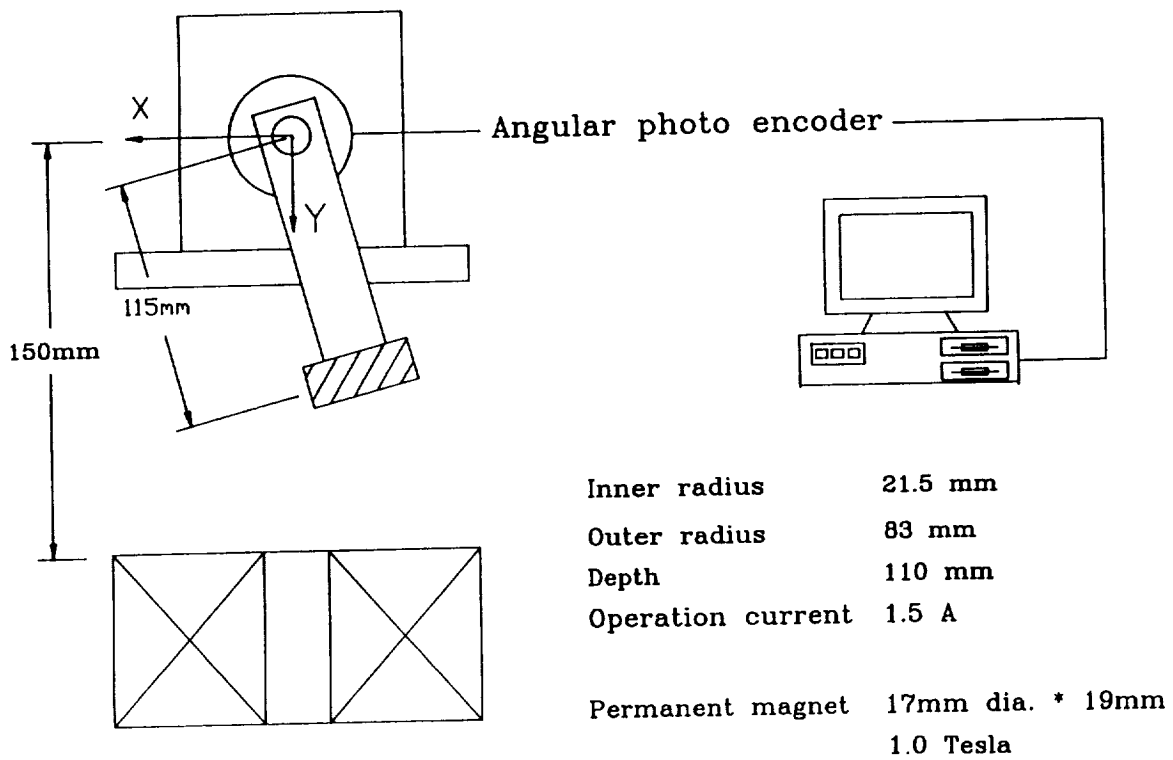

Figure 1. Configuration of the Experimental Set-up.

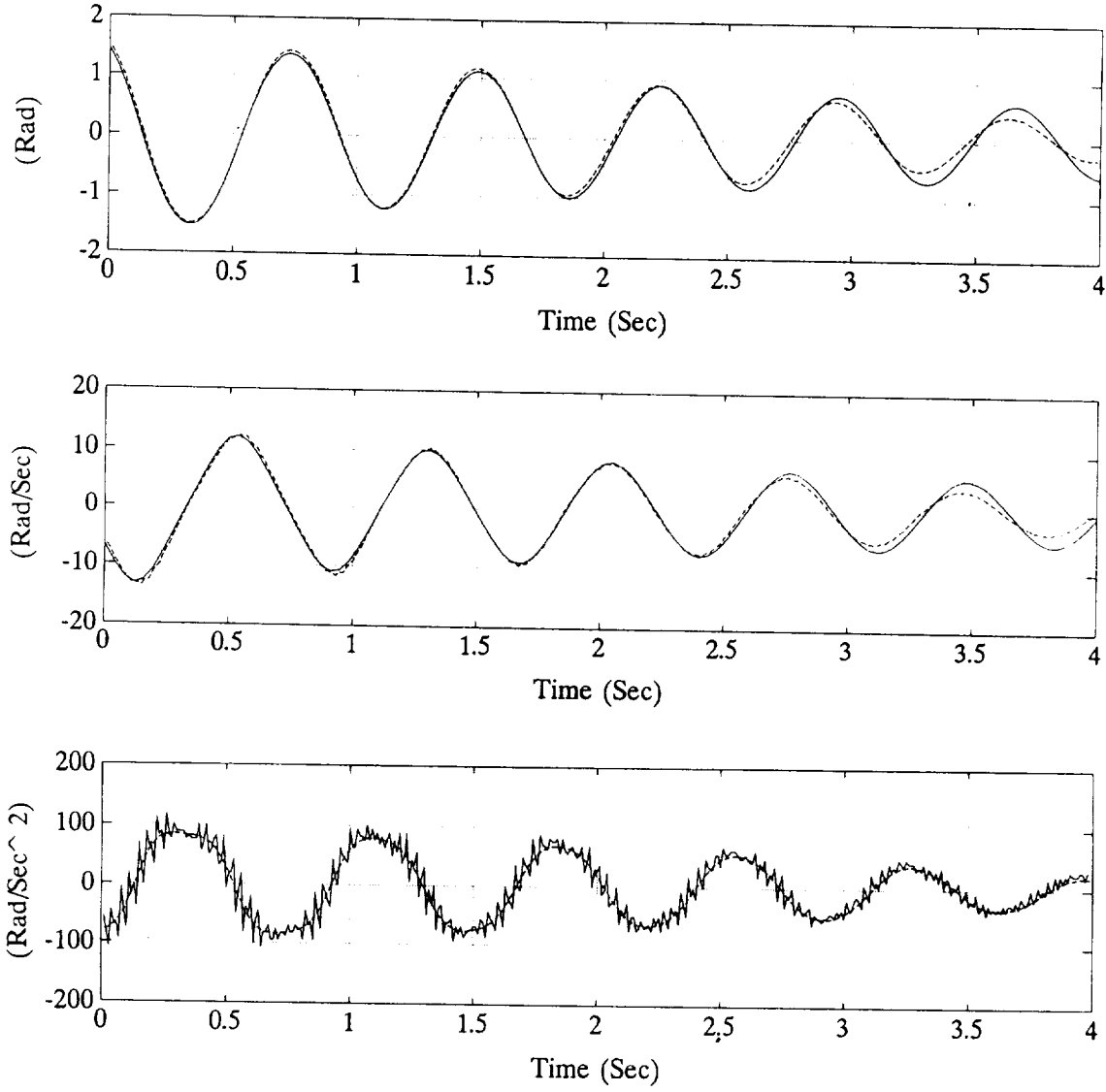

Figure 2. Experimental and Simulation Results in Pendulum Motion.

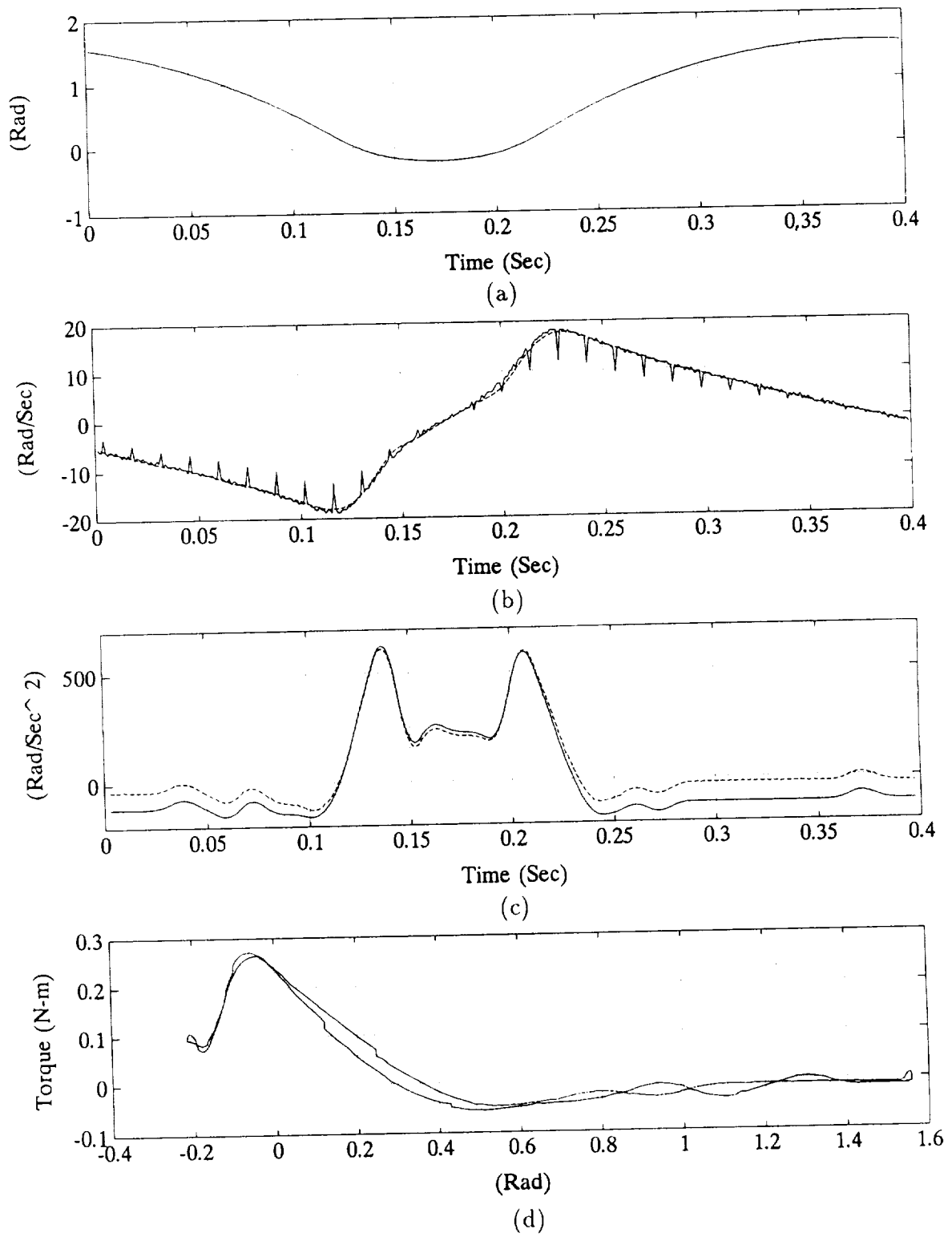

Figure 3. Pendulum Motion in Magnetic field: (a) Angular Change, (b) Angular Velocity and Fitting Line, (c) Corrective Angular Acceleration, (d) Magnetic Torque.

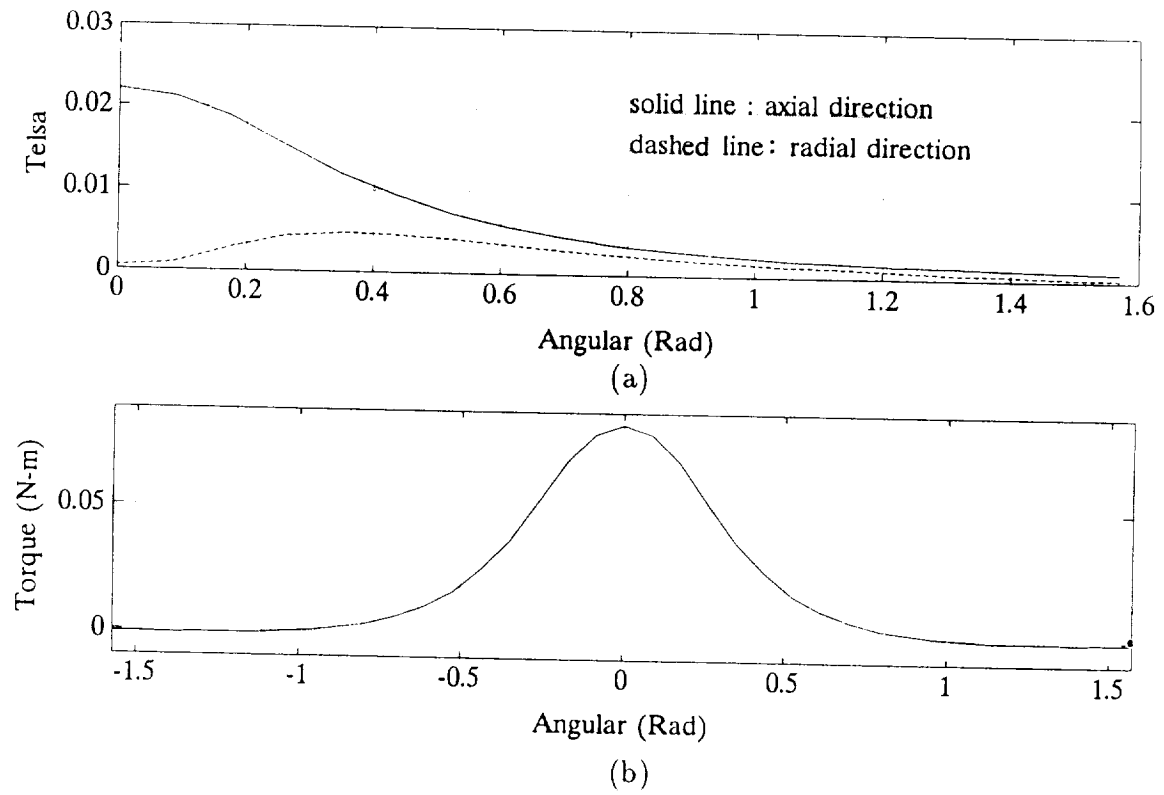
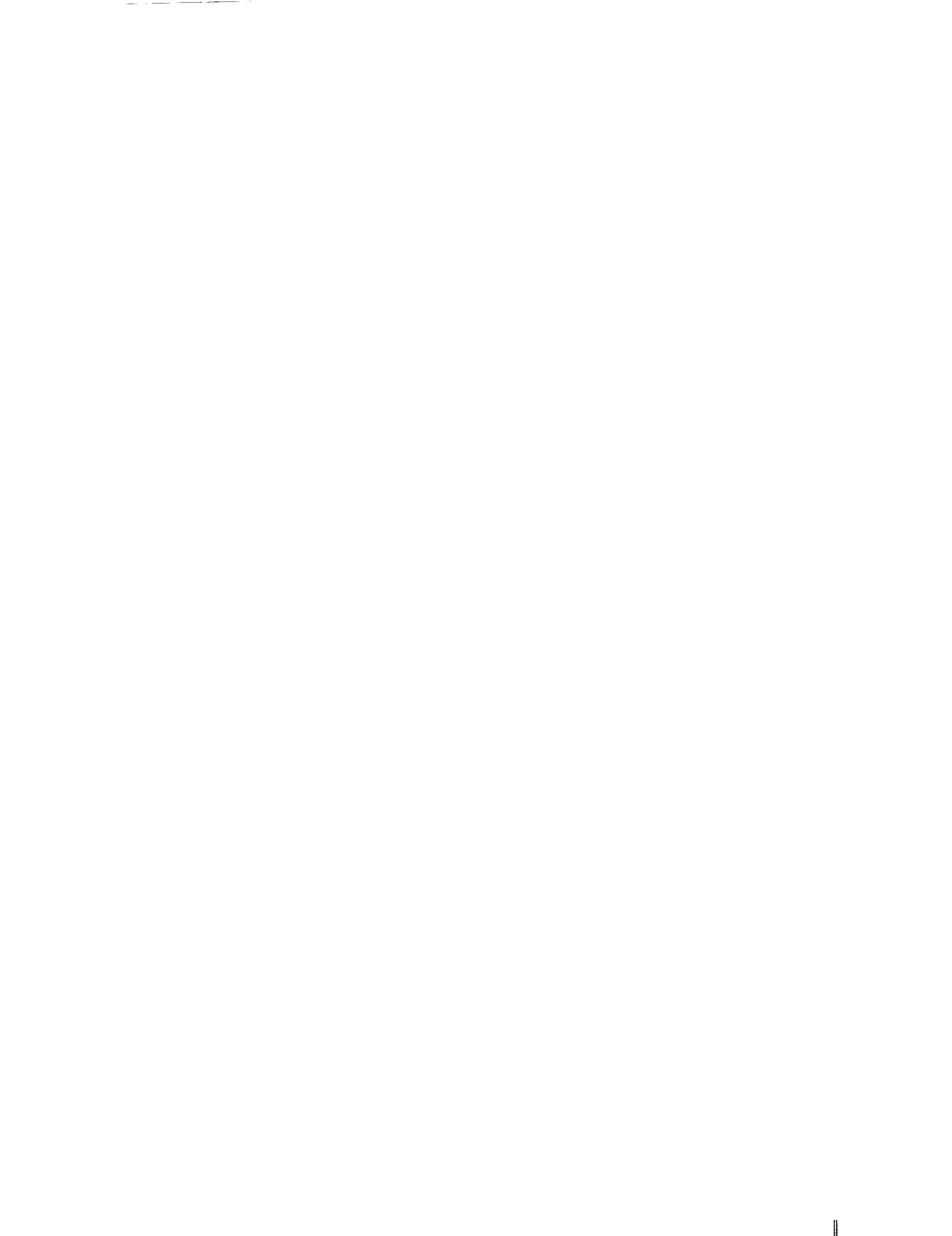

Figure 4. (a) Magnetic Field in the Pendulum Locus, (b) Magnetic Torque Obtained from the Formula $\vec{T} = vol(\vec{M} \times \vec{B})$.



Session 7a – Bearing Modeling

Chairman: Hideo Sawada
National Aerospace Laboratory

PRECEDING PAGE BLANK NOT FILMED

PAGE 316
PRECEDING PAGE BLANK

