

THIRD ORDER LPF TYPE COMPENSATOR FOR FLEXIBLE ROTOR SUSPENSION

Osami Matsushita
The National Defense Academy

Naohiko Takahashi
Tsuchira Works, Hitachi, Ltd.

Michiyuki Takagi
Mechanical Engineering Research Laboratory, Hitachi, Ltd.

ABSTRACT

The tuning job of the compensator for levitating flexible rotors supported by active magnetic bearings (AMB) concerns providing a good damping effect to the critical speed modes while avoiding the spillover problem on the instability of higher bending modes. In this paper, an idea for design of the control law of the compensator based on utilizing a third order low pass filter (LPF) is proposed to essentially enable elimination of the spillover instability. According to the proposed design method, good damping effects for the critical speeds are obtained by the usual phase lead/lag function. Stabilization for all of higher bending modes is completed by the additional function of the 3rd order LPF due to its phase lag approaching about -270 degrees in the high frequency domain. This idea is made clear by experiments and simulations.

INTRODUCTION

To design control network driving active magnetic bearings (AMB) for flexible rotor levitation, it is important to consider rigid mode levitation, controllability of flexible modes at critical speeds and a stability margin for high frequency bending modes. For instance, a design of super critical compressors supported by AMBs illustrates this point. In the first design phase, rigid mode levitation performance is determined. Next, the well damping ratio of the first bending mode necessary to pass the critical speed is determined according to Q-value criteria. Finally, the PID controller transfer function is tuned so as to satisfy these two requirements and so as to avoid higher frequency instability beyond 2nd bending modes. It is called a spillover problem.⁽¹⁾

Usually, the PID control law with optional notch filters and/or low pass filters is used for tuning. Otherwise, the increase of the internal damping of the rotor is improved. However, this design method based upon the phase lead/lag function is not free from the spillover problem. However, the presented method can provide a highly robust control system for the higher modes and satisfactory performance for the controlled modes. It is possible to skillfully combine the commonly used phase lead/lag function with the 3rd order LPF. How to design the 3rd order LPF is a main point of this paper.

The phase lead/lag function can possibly provide enough damping performance to the rigid and first bending modes. It can be done by placing these critical speeds in the phase lead domain. If a flexible rotor system requires higher damping than one provided by the phase lead function, some

optional function can be used just for passing the bending critical speeds. According to our experiences, an optional network, called N-CROSS, is recommended.^[2] It works only around the critical speeds of the shaft bending modes during the rotor rotation. Then, the problem is how to design the compensator featuring no spillover to potentially stabilize all the eigen modes.

The proposed design method features the addition of the 2nd order LPF to the usual PID compensator in order to realize this 3rd order LPF. The center frequency of the 2nd order LPF coincides with the eigen frequency of the rotor restricted by pin-pin boundary at AMB portions. This eigen frequency is equal to the anti-resonance frequency located between the 1st and 2nd bending modes. Since the total function of the controller network becomes a 3rd order LPF, the phase lag forwards to -270 degrees, i.e., a 90 degree phase lead, in the high frequency domain. Therefore, all the higher natural frequencies beyond the 2nd bending mode are essentially stable, i.e., completely free from the spillover problem.

This idea is theoretically explained for a rotor system with one AMB support. The effectiveness of this design method is proven by numerical simulations and experimental results. The rotation test is done with a low enough Q-value to pass the rigid and first bending critical speed without the high frequency instability. The generalization of this design concept is finally proposed for the flexible rotor borne by two AMBs.

A FLEXIBLE ROTOR WITH ONE ACTIVE MAGNETIC BEARING

A flexible rotor shown in Fig.1 is selected for explaining the fundamental idea of the design method of AMB compensator. The rotor is supported by a ball bearing at the right end and by an AMB at the other. The ball bearing placed here is represented by the pin boundary condition to explain the idea clearly. The problem then focuses on to how to design the compensator driving the AMB at the left side.

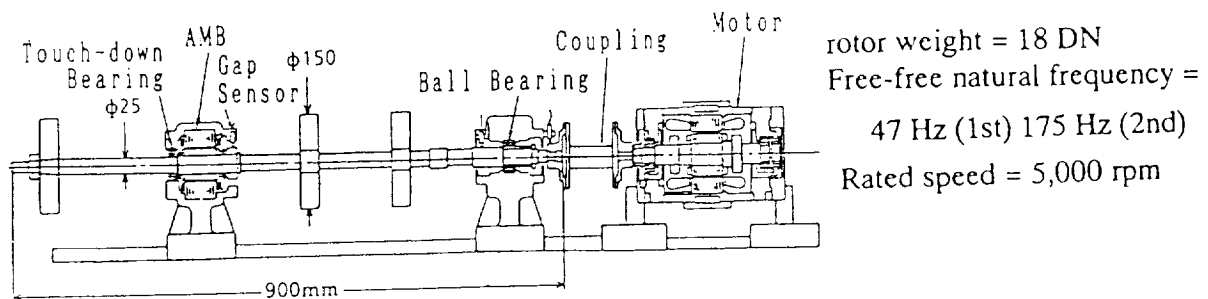

Fig.1 Experimental test rig

A gap sensor placed at the left side detects the rotor radial displacement which feeds its signal to the controller. The signal from the controller drives the magnetic bearing force through the power amplifier having a transfer function of unity. The rotor is connected to a motor with a flexible coupling. The flexible coupling is flexible enough to satisfy the free boundary condition at the right end of the rotor as shown Fig.2(a). Gyroscopic effects are neglected here.

The displacement vector is noted by $X=[X_1^T, X_2^T]^T$; X_2 for the rotor displacement at the AMB portion and X_1 for the displacements of all portions of the rotor except the AMB portion. The former is called the boundary displacement and the latter called the inner displacement vector. In the AMB

servo-control system, the boundary displacement X_2 is measured and the AMB force U acts upon the rotor according to a control law. Then, the equation of motion of the rotor-bearing system can be written in matrix form as follows:

$$\begin{bmatrix} M_1 & \\ & M_2 \end{bmatrix} \begin{bmatrix} \ddot{X}_1 \\ \ddot{X}_2 \end{bmatrix} + \begin{bmatrix} K_{1,1} & K_{1,2} \\ K_{1,2}^t & K_{2,2} \end{bmatrix} \begin{bmatrix} X_1 \\ X_2 \end{bmatrix} = \begin{bmatrix} 0 \\ 1 \end{bmatrix} u \quad (1)$$

where M_i and K_{ij} ($i,j=1,2$) indicate mass and stiffness matrices of the rotor system, respectively, noted by 1 for the inner portion and by 2 for the boundary AMB portion.

Any damping factors, e.g., shaft material damping, mechanical dampers, are neglected. In the authors' opinion, the consideration of such system damping factors, in addition, will potentially destroy the realization of practical robust control. Rotordynamics designers want to consider the compensator design for the AMB, similarly, the design for oil-film bearings, i.e., neglecting any system damping.

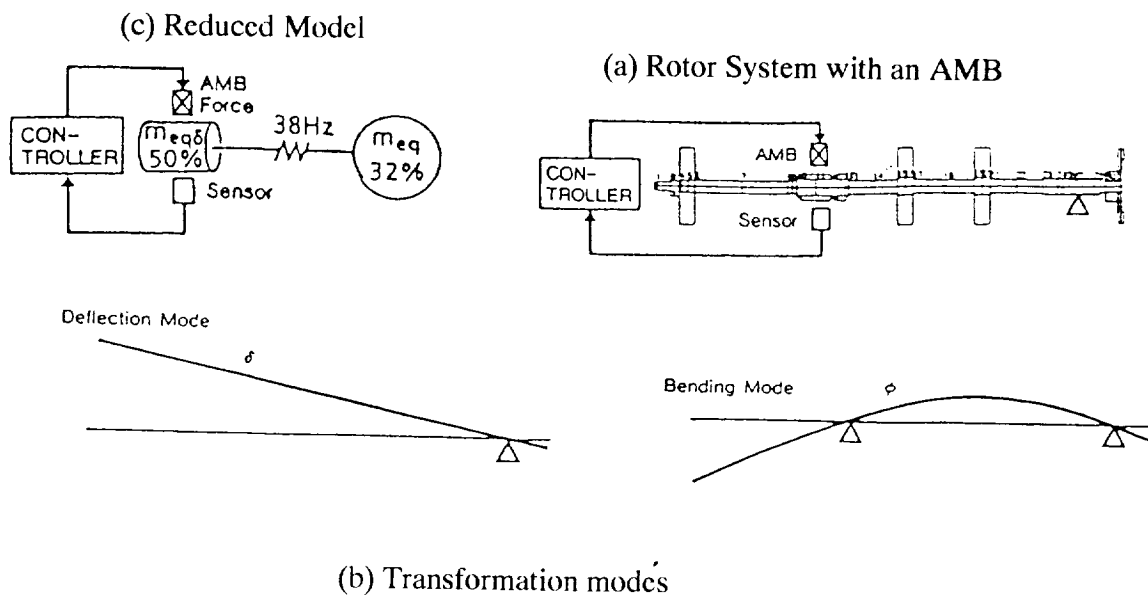

Fig.2 Modelling by quasi-modal transformation

SYSTEM MODELLING

The equation of motion (1) of the rotor is formulated in FEM matrix forms on meshing by the shaft beam element. The quasi-modal system reduction in a category of the modal synthesis is applied to the original system.^[3] The quasi-modal transformation modes are determined by two kinds of modes as shown in Fig.2(b):

- (1) Pure bending mode ϕ obtained by eigen mode of the rotor if the pin condition is imposed at the AMB portion.
- (2) Rigid mode δ obtained by deflection mode if the rotor is lifted to give the unit displacement at the AMB portion.

The quasi-modal transformation is defined by the following equation:

$$\chi = \begin{bmatrix} x_1 \\ x_2 \end{bmatrix} = \begin{bmatrix} \phi & \delta \\ 0 & 1 \end{bmatrix} \begin{bmatrix} s \\ x_2 \end{bmatrix} \quad (2)$$

where the variable s is a weighting value indicating the magnitude of the pure bending mode obtained in the rotor bending critical speed mode.

From the result of the transformation, the following equation of motion of the reduced model having 2 degrees of freedom is completed:

$$\begin{bmatrix} m^* & m_c \\ m_c & m_\delta \end{bmatrix} \begin{bmatrix} \ddot{s} \\ \ddot{x}_2 \end{bmatrix} + \begin{bmatrix} k^* & 0 \\ 0 & 0 \end{bmatrix} \begin{bmatrix} s \\ x_2 \end{bmatrix} = \begin{bmatrix} 0 \\ 1 \end{bmatrix} u, \quad (3)$$

where $m^* = \phi^T M_1 \phi$, $m_c = \phi^T M_1 \delta$, $m_\delta = M_2 + \delta^T M_1 \delta$, $k^* = m^* \omega_p^2$ and

ω_p = the natural frequency of the pure bending mode under the pin boundary condition at the AMB portion.

This equation of motion having the mass interaction between the pure bending mode and the rigid mode is equivalently converted to the spring interaction. This conversion is possible to provide the reduced vibrating model visually composing the mass-spring connection, if a new absolute displacement x^* is introduced as $s = a(x^* - x_2)$:

$$a = m_c / m^* = \phi^T M_1 \delta / \phi^T M_1 \phi \quad (4)$$

$$\begin{bmatrix} m_{e\phi} & \\ & m_{e\phi\delta} \end{bmatrix} \begin{bmatrix} \ddot{x}^* \\ \ddot{x}_2 \end{bmatrix} + \begin{bmatrix} k_{e\phi} & -k_{e\phi} \\ \text{sym.} & k_{e\phi} \end{bmatrix} \begin{bmatrix} x^* \\ x_2 \end{bmatrix} = \begin{bmatrix} 0 \\ 1 \end{bmatrix} u, \quad (5)$$

where $m_{e\phi} = a^2 m^*$, $m_{e\phi\delta} = m_\delta - m_{e\phi}$, $k_{e\phi} = m_{e\phi} \omega_p^2$ and $a = m_c / m^* = \phi^T M_1 \delta / \phi^T M_1 \phi$

The obtained model is illustrated in Fig.2(c). The masses of $m_{e\phi\delta}$ and $m_{e\phi}$ indicate the equivalent masses of the rigid mode and the pure bending mode, respectively.

CONVENTIONAL DESIGN CONCEPT FOR COMPENSATOR

The negative spring effect exhibited by the AMB is neglected. It can be easily compensated by certain gain of the proportional action. The equation of motion (5) of the model is rewritten by the state equation form as follows:

$$\begin{aligned} \dot{\chi} &= AX + bu \\ y &= cX \end{aligned} \quad (6)$$

where

$$X = \begin{bmatrix} x_2 \\ \dot{x}^* \\ x_2 \\ \dot{x}^* \end{bmatrix}, \quad A = \begin{bmatrix} 0 & 0 & 1 & 0 \\ 0 & 0 & 0 & 1 \\ -k_{e\tau}/m_{e\tau} & k_{e\tau}/m_{e\tau} & 0 & 0 \\ k_{e\tau}/m_{e\tau} & -k_{e\tau}/m_{e\tau} & 0 & 0 \end{bmatrix}, \quad b = \begin{bmatrix} 0 \\ 0 \\ 1/m_{e\tau} \\ 0 \end{bmatrix} \quad \text{and}$$

$$c = [1 \ 0 \ 0 \ 0]$$

The controller design based upon the modern control theory combining the full order observer and the optimum feedback gain due to LQR is applied to the model in the manner as shown in Fig.3.^[4]

One example of the transfer function of the compensator itself is obtained as shown in Fig.4. The overall configuration of the transfer function is fundamentally similar to PID action, but down slope gain of 1st order LPF at the high frequency domain.

The free-free eigen frequency is indicated by the bottom points of the dotted curve. Therefore, the damping ratio of the rigid and first bending mode of the global system can be well provided. However, higher bending modes than the 2nd will be easily unstable due to the phase lag at this high frequency domain.

In fact, the phase curve on the Bode diagram changes from the phase lead region to the phase lag region beyond the peak portion of the gain curve. This phase lag forwarding to -90 degrees provides a negative damping effect for high frequency eigen modes of the global system. This is the reason why the spillover instability is induced.

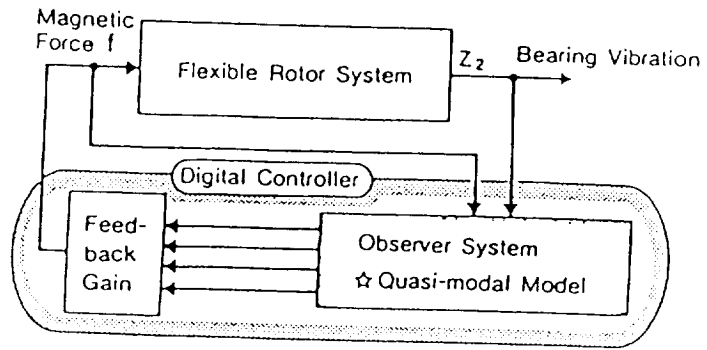

Fig. 3 Conventional control layout

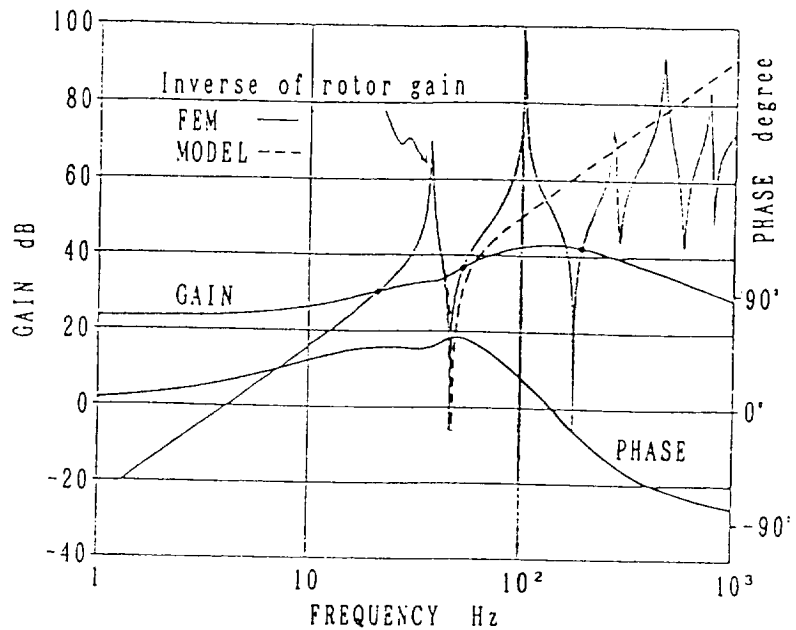

Fig.4 Controller transfer function (Conventional design)

PROPOSED DESIGN CONCEPT FOR COMPENSATOR

The idea of the new design comes from the fact that if this phase lag forwards to -270 degrees instead of -90 degrees, the compensator can provide the positive damping to the system even in the high frequency domain.^[5] This idea can be realized by replacing the behavior of the 1st order LPF of the conventional compensator by one of the 3rd order LPF. In other words, it is easily completed by the cascade combination of the present type plus a 2nd order LPF as shown in Fig.5.

The type of the 2nd order LPF that must be added is now discussed. It is recommended that the center frequency of the 2nd order LPF is tuned with the anti-resonance frequency, i.e., the eigen frequency of the pure bending mode. This is because the rotor does not react to the resonance of the 2nd order LPF in the control network.

If the LQR method stated in the APPENDIX is applied to a control object, composing the rotor and this 2nd order LPF, the required compensator is automatically designed. One of the transfer functions of the proposed compensator is shown in Fig.6 including the 2nd order LPF. The dotted curve indicates the inverse function of rotor response against force input, called the rotor gain. The peak of the dotted curve indicates the anti-resonance frequency in which the amplitudes of the corresponding AMB portions are zero, i.e., nodes on the pin-pin eigen modes.

In this figure, the phase lead covers the natural frequency of the rigid and first bending modes to provide the well damping effects at the critical speeds. The phase lag starts beyond 80 Hz, but it quickly passes -180 degrees before the 2nd bending mode and it finally moves forward to -270 degrees. Therefore, positive damping is provided to all bending modes of the global system beyond the 2nd mode, ensuring stability. As obviously shown in this phase curve, all of the higher frequency modes are definitely stable. There is no spillover problem. This controller will be robust from the practical viewpoint of the AMB compensator design.

The result of the eigenvalue of the global system is shown in Table 1. Clearly all modes are completely stabilized even with no material damping.

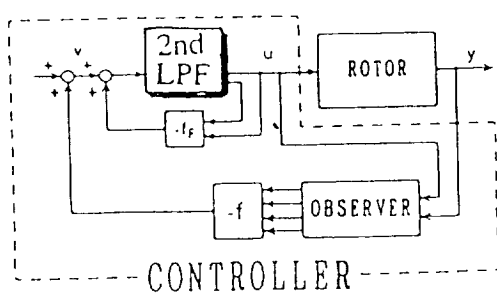

Fig. 5 Control layout
(Proposed design)

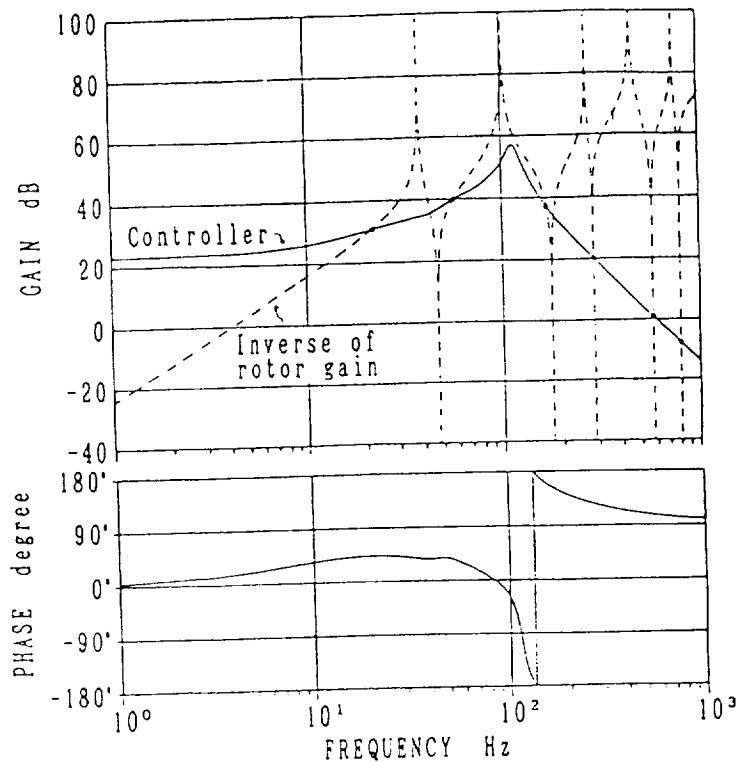

Fig.6 Controller transfer function
(Proposed design)

Table 1. Eigenvalue of the Flexible Rotor

Mode	Orpm eigen value (ζ %, Hz)	
	Open loop	Closed loop
Rigid mode	0, 0	61.65038, 20
1st bending mode	0, 47	16.24556, 48
2nd bending mode	0, 175	2.82522, 169
3rd bending mode	0, 285	0.05888, 285
4th bending mode	0, 374	0.00009, 374

EXPERIMENTAL RESULTS

A control law is made by digital means with the following specifications:

- Bilinear S-Z transformation used for digitalization,
- 8 KHz for sampling frequency and
- DSP board (type ADSP320 made by Chubu Denki)

In the experiment, the integral action is added for statically levitating the rotor. A proportional action is also included in addition, for cancelling the negative spring effect in the AMB.

For experimentally checking the stability of the developed control law of the 3rd order LPF, it is compared with the commonly used PID control law as shown in Fig.7. In the case of the PID control, depending on the increase of the feedback loop gain, the instability of the 5th bending mode appears when the natural frequency of the rigid mode reaches 13 Hz. However, in the case of the 3rd LPF control, even if the rigid mode natural frequency is increased to 24 Hz, the bending mode instability does not appear. This proposed controller is thus very robust.

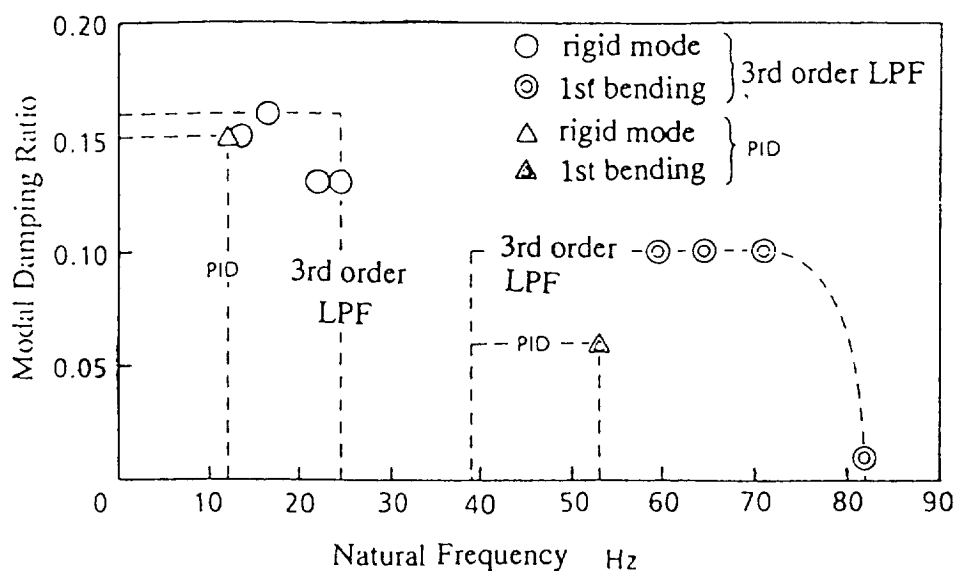

Fig. 7 Comparison of improvement of system damping by tuning

As shown in Fig.8, the vibration response curves are measured. Compared with the PID, enough damping effect is provided by the proposed controller for the rigid and first bending modes at the critical speeds. Small peak amplitudes are obtained compared with the conventional type.

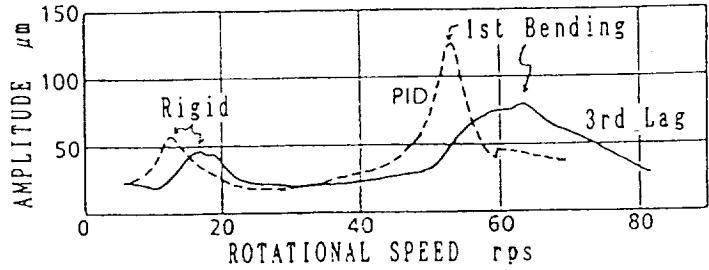

Fig. 8 Vibration response curves

As suggested in Fig.9 of the relation between the natural frequency versus the AMB stiffness, the compensator design concept is as follows:

- 1st eigen mode (rigid mode) and 2nd eigen mode (1st bending mode) can take enough damping ratio to pass the critical speeds owing to the phase lead. Consequently small Q-value design is completed. If necessary, the N-cross can be optionally added for making the Q-value of the 1st bending mode smaller.
- The higher eigen modes than the 3rd (2nd bending mode) are stabilized due to the phase lag of about -270 degrees. The spillover problem completely disappears for any higher frequency mode.
- The center frequency of the additional 2nd order LPF must be set with the anti-resonance frequency located between the 2nd and 3rd eigen modes (1 and 2nd bending modes). Even if the Q-value of the 2nd order LPF is high, the rotor does not react to such sensitivity as high as in the compensator network.

GENERALIZATION OF PROPOSED DESIGN CONCEPT

The rotor borne by two AMBs at the left and right sides is quite common. The concept of the compensator design developed for one AMB type can be enhanced to two AMB types. The natural

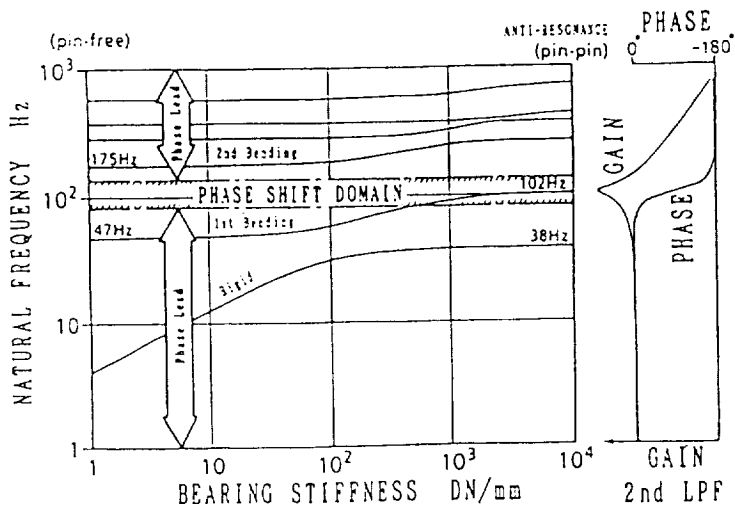

Fig. 9 Natural frequency map (One AMB)

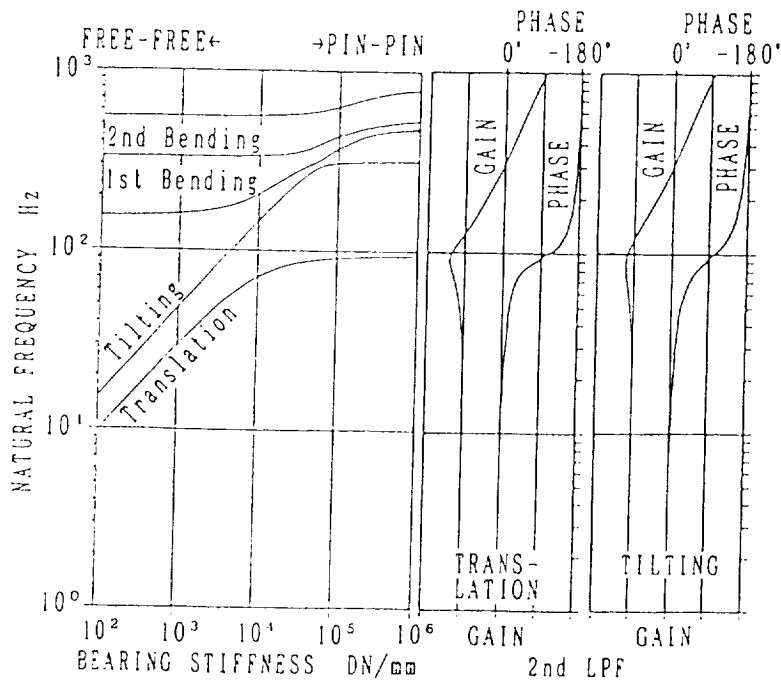

Fig. 10 Natural frequency map (Two AMBs)

frequency map is shown in Fig.10. On the left side of the map the natural frequency of the rotor subjected to free-free boundary condition is plotted. On the right side the natural frequency is that of the pin-pin boundary condition. The right side frequencies indicate anti-resonance frequencies.

For the type of two AMB there are two types of controller layouts: centralized and decentralized. The centralized layout employing the translation and tilting mode controls are suitable for the control law of the 3rd order LPF. The separation into both the modes and two independent compensators are prepared as shown in Fig.11.

According to this separation, two types of the compensator are independently designed, based on the design concept developed for the one AMB control :

- type 1 : translation mode compensator to control mainly the parallel rigid mode and the 1st bending mode of the rotor.
- type 2 : tilting mode compensator to control mainly the conical rigid mode. (The 2nd bending mode of the rotor must be included in the control frequency band, if necessary.)

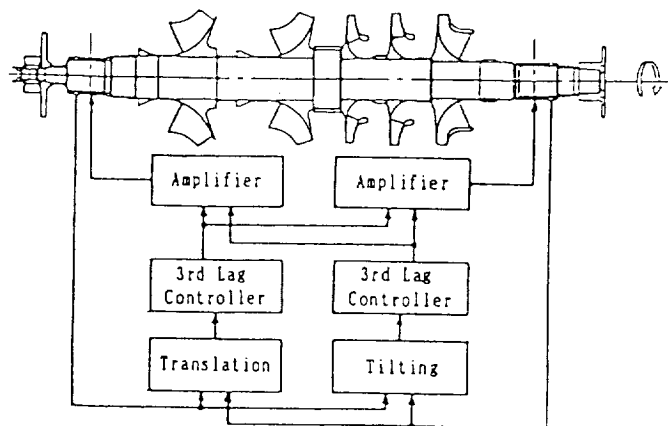

Fig. 11 Centralized controller layout

The obtained transfer functions of each compensator are shown in Fig.12 and 13. The center frequency of the 2nd order LPF coincides with the 1st anti-resonance frequency of the rotor under the pin-pin boundary condition, as shown in the natural frequency map of Fig.10.

The stability analysis of the global system is shown in Table 2. All of the bending modes are stabilized without spillover problems, even if no material damping. Clearly the completed regulators are very robust.

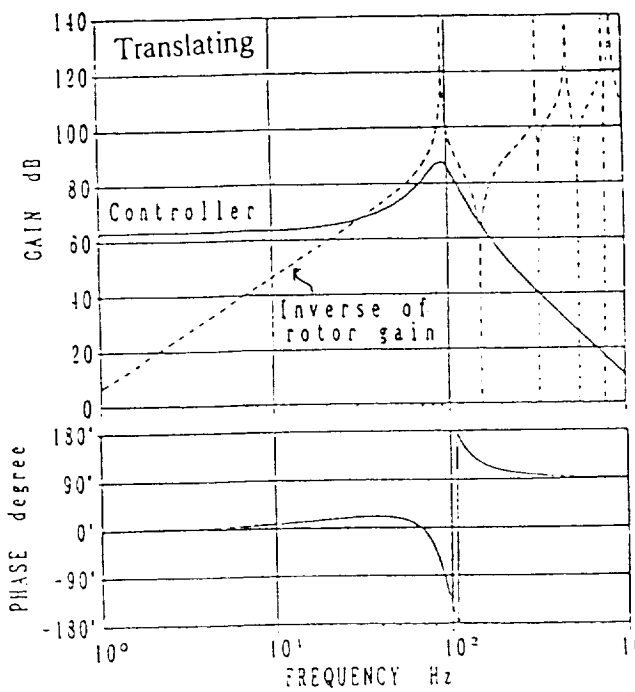

Fig. 12 Transfer function for translation mode controller

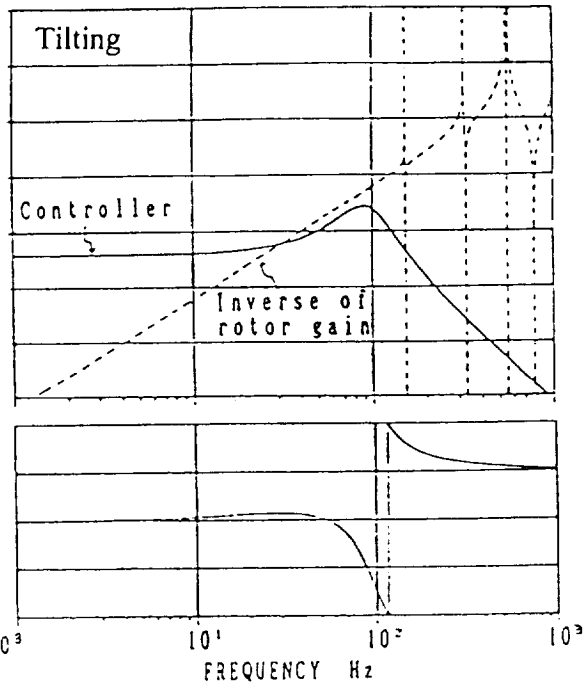

Fig. 13 Transfer function for tilting mode controller

Table 2 Eigenvalues of the Rotor (2 AMBs)

Mode	Orpm eigen value (ζ %, Hz)	
	Open loop	Closed loop
Translation mode	0, 0	26.66492, 29
Tilting mode	0, 0	18.48787, 31
1st bending mode	0, 154	2.93966, 152
2nd bending mode	0, 331	0.00290, 331
3rd bending mode	0, 555	0.00091, 555
4th bending mode	0, 786	0.00023, 786

CONCLUSION

A design concept for AMB control based on a 3rd order LPF is presented. It is a key point that the center frequency of the 2nd order LPF within it must be set by the anti-resonance frequency of the rotor. The rotor system can be stabilized by positive damping due to phase lead for the rigid and 1st bending modes, and due to phase lag with about -270 degree for the higher bending modes. The completed compensator can potentially stabilize all of the bending modes with no material or structure of damping. The effectiveness of this design concept is proven in the experiment using the rotor having one AMB.

This concept is generalized for the flexible rotor borne by two AMBs, as this is a common type, and its effectiveness is made clear by simulation.

REFERENCES

- [1] K. Nonami et.al., Spillover Control of Magnetic Levitation Sytem Using H Infinity Control Theory, Trans. of JSME, Vol57, No.534, (1991-2), p.568 (in Japanese)
- [2] O. Matsushita et.al, Control of Rotor Vibration due to Cross Stiffness Effect of Active Magnetic Bearing, The International Conference on ROTORDYNAMICS, IFToMM Sep 1Control0-12, 1990, Lyon, p515
- [3] O. Matsushita et.al, Flexible Rotor Vibration Analysis Combined with Active Magnetic Bearing Control, The International Conference on ROTORDYNAMICS, IFToMM Sep 14-17, 1986, Tokyo, p421
- [4] T.Kida, et.al. 2, Optimal Regulator with Low-Pass Property and Its Application to LSS Control, Trans. of the Society of Instrument and Control Engineers (SICE) Vol.25, No.4, p.448-454, (1989-4), (in Japanese)
- [5] Y. Tagawa et.al., Modeling and Attitude Control of Flexible Spacecraft, Trans. of JSME, Vol .54, No.507, (1988-11), p.2689 (in Japanese)

APPENDIX

By using a control objector composing of the rotor and a 2nd order LPF, the compensator of the 3rd order LPF is automatically designed. The corresponding state equation of this enlarged objector as shown in Fig.5 is written by the following formulas:

$$\begin{aligned} \begin{bmatrix} \dot{X} \\ \dot{Z} \end{bmatrix} &= \begin{bmatrix} A & bc_F \\ 0 & A_F \end{bmatrix} \begin{bmatrix} X \\ Z \end{bmatrix} + \begin{bmatrix} 0 \\ b_F \end{bmatrix} v \\ y &= [c \quad 0] \begin{bmatrix} X \\ Z \end{bmatrix} \\ u &= c_F Z \end{aligned} \tag{7}$$

where

$$Z = \begin{bmatrix} z \\ \dot{z} \\ z \end{bmatrix}, \quad A_F = \begin{bmatrix} 0 & 1 \\ -\omega_F^2 & -2\zeta_F \omega_F \end{bmatrix}, \quad b_F = \begin{bmatrix} 0 \\ \omega_F^2 \end{bmatrix} \quad \text{and} \quad c_F = [1 \quad 0]$$

From the state eqation, a control law obtained by the LQR manner is thus shown in Fig.6.



REPORT DOCUMENTATION PAGE			Form Approved OMB No. 0704-0188	
Public reporting burden for this collection of information is estimated to average 1 hour per response, including the time for reviewing instructions, searching existing data sources, gathering and maintaining the data needed, and completing and reviewing the collection of information. Send comments regarding this burden estimate or any other aspect of this collection of information, including suggestions for reducing this burden, to Washington Headquarters Services, Directorate for Information Operations and Reports, 1215 Jefferson Davis Highway, Suite 1204, Arlington, VA 22202-4302, and to the Office of Management and Budget, Paperwork Reduction Project (0704-0188), Washington, DC 20503.				
1. AGENCY USE ONLY (Leave blank)	2. REPORT DATE May 1994	3. REPORT TYPE AND DATES COVERED Conference Publication		
4. TITLE AND SUBTITLE Second International Symposium on Magnetic Suspension Technology			5. FUNDING NUMBERS WU 233-03-01-01	
6. AUTHOR(S) Nelson J. Groom and Colin P. Britcher, Editors				
7. PERFORMING ORGANIZATION NAME(S) AND ADDRESS(ES) NASA Langley Research Center Hampton, VA 23681-0001			8. PERFORMING ORGANIZATION REPORT NUMBER L-17369	
9. SPONSORING/MONITORING AGENCY NAME(S) AND ADDRESS(ES) National Aeronautics and Space Administration Washington, DC 20546-0001			10. SPONSORING/MONITORING AGENCY REPORT NUMBER NASA CP-3247 Part 1	
11. SUPPLEMENTARY NOTES Nelson J. Groom: Langley Research Center, Hampton, VA; Colin P. Britcher: Old Dominion University, Norfolk, VA				
12a. DISTRIBUTION/AVAILABILITY STATEMENT Unclassified-Unlimited Subject Category 18			12b. DISTRIBUTION CODE	
13. ABSTRACT (Maximum 200 words) In order to examine the state of technology of all areas of magnetic suspension and to review related recent developments in sensors and controls approaches, superconducting magnet technology, and design/implementation practices, the 2nd International Symposium on Magnetic Suspension Technology was held at the Westin Hotel in Seattle, Washington on August 11-13, 1993. The symposium included 18 technical sessions in which 44 papers were presented. The technical sessions covered the areas of bearings, bearing modelling, controls, vibration isolation, micromachines, superconductivity, wind tunnel magnetic suspension systems, magnetically levitated trains (MAGLEV), rotating machinery and energy storage, and applications. A list of attendees appears at the end of the document.				
14. SUBJECT TERMS Magnetic bearings; Magnetic suspension; Large gap magnetic suspension; Small gap magnetic suspension; Sensors; Superconducting magnetic suspension systems; Control systems			15. NUMBER OF PAGES 447	
			16. PRICE CODE A19	
17. SECURITY CLASSIFICATION OF REPORT Unclassified	18. SECURITY CLASSIFICATION OF THIS PAGE Unclassified	19. SECURITY CLASSIFICATION OF ABSTRACT Unclassified	20. LIMITATION OF ABSTRACT	