

Handwritten notes:
11-2-94
7-7

NASA Contractor Report 191195
R94AEB175

Fiber Optic (Flight Quality) Sensors For Advanced Aircraft Propulsion

Final Report

Gary L. Poppel
GE Aircraft Engines
Cincinnati, Ohio 45215

July 1994

Prepared for:
Robert J. Baumbick, Project Manager
National Aeronautics and Space Administration
21000 Brookpark Road
Cleveland, Ohio 44135

Contract NAS3-25805



(NASA-CR-191195) FIBER OPTIC
(FLIGHT QUALITY) SENSORS FOR
ADVANCED AIRCRAFT PROPULSION Final
Report, Jan. 1990 - Jun. 1994 (GE)
90 p

N94-37401

Unclas

G3/06 0016023



TABLE OF CONTENTS

Section		Page
1.0	SUMMARY	1
2.0	INTRODUCTION	2
3.0	SENSOR SET DESCRIPTION	3
	3.1 Identification and Requirements	3
	3.2 Engine/System Schematics	3
	3.3 F404 Implementation	5
	3.4 Optical/Electrical Signal Comparison	8
4.0	SENSOR DESIGN, FUNCTIONALITY, & TESTING	9
	4.1 T1 Temperature Sensor	9
	4.2 T2.5 Temperature Sensor	10
	4.3 T5 Temperature Sensor	11
	4.4 FVG Position Sensor	12
	4.5 CVG Position Sensor	14
	4.6 VEN Position Sensor	15
	4.7 NL Speed Sensor	16
	4.8 NH Speed Sensor	17
	4.9 AB Flame Detector	18
5.0	ELECTRO-OPTIC CIRCUITRY	20
	5.1 Litton EOA Circuitry	20
	5.2 GE Circuitry	23
	5.3 Conax T5 Signal Processor	24
	5.4 Ametek AB Flame Detector Assembly	25
6.0	ELECTRO-OPTICS UNIT DESIGN, ASSEMBLY, & TESTING	26
	6.1 Chassis Design	26
	6.2 Assembly Process	26
	6.3 Internal Features	26
	6.4 Input/Output Interfaces	27
	6.5 Thermal Studies	27
	6.6 Testing	27
7.0	CABLE DESIGN & FABRICATION	33
	7.1 Identification of Cable Set	33
	7.2 Optical Sensor Loop Configurations	33
	7.3 GE-Designed Fiber Optic Cables	33
	7.4 Supplier Designed Fiber Optic Cables	37
	7.5 Electrical Cables	37
8.0	INSTALLATION OF HARDWARE ON ENGINE	38
	8.1 Sensor Installations	38
	8.2 Cable Routing/Installation	39
	8.3 EOU Installation	39
	8.4 F-18/Engine Interface Issues	40

TABLE OF CONTENTS (Concluded)

Section		Page
9.0	GE FLIGHT READINESS REVIEW	46
	9.1 Review Purpose	46
	9.2 Generated Chits & Responses	46
10.0	ENGINE GROUND TESTING	48
	10.1 First Engine Test	48
	10.2 Second Engine Test	49
11.0	DISCUSSION OF RESULTS	51
	11.1 Sensing Techniques	51
	11.2 Design	51
	11.3 Fabrication	52
	11.4 Component Testing	52
	11.5 System Integration	53
12.0	CONCLUSION	54
	APPENDIX A - Supplier Selection	55
	APPENDIX B - Hardware Photographs	56
	APPENDIX C - NL Optical Speed Sensing Using Pressure Pulses	80
	APPENDIX D - Abbreviations	81
	REFERENCES	82

LIST OF ILLUSTRATIONS

Figure		Page
1	FOCSI Fiber Optic Sensors On the F404-400 Engine	3
2	FOCSI System Schematic	4
3	Optical T1 Temperature Sensor Mounts In the Aircraft's Engine Intake	5
4	Installation of Optical T2.5 Temperature Probe Through F404-400 CIT Transmitter Flange	6
5	Aft Looking Forward View of Electrical/Optical T5 Temperature Probes On F404-400 Engine	7
6	Fiber Optic NL Speed Sensor Interface With F404-400 NL Speed Sensor	7
7	AB Flame Sensor Configurations	8
8	T1 Temperature Sensor Housing Configurations	9
9	T2.5 Temperature Probe Package	11
10	Physical Outline of T5 Probe/Harness Assembly	12
11	Outline Drawing of FVG Position Sensor	13
12	Outline Drawing of CVG Position Sensor	14
13	Outline Drawing of VEN Position Sensor	15
14	NL Speed Sensor Assembly	16
15	Outline Drawing of NH Speed Sensor	18
16	AB Flame Detector Components	19
17	G&H Fiber Optic Terminus Configuration For EOA Backplane	22
18	Modified SEM-E Connector and Backplane Insert For Backplane Fiber Optic Terminus	23
19	Conax T5 Signal Processor	25
20	Internal Schematic of EOU Assembly	28
21	Internal/External Features of EOU Assembly	29
22	Internal/External Features of EOU Assembly	30
23	Optical Fiber Configuration For NL/NH Sensors	34
24	Optical Fiber Configuration For FVG/CVG Sensors	34

LIST OF ILLUSTRATIONS (Continued)

Figure		Page
25	Optical Fiber Configuration For T1 Sensor	35
26	Optical Fiber Configuration For T2.5 and VEN Sensors	36
27	F404-400 Alternator Layout Showing Installation of Fiber Optic NH Sensor	40
28	Additional Engine-To-Airframe Cables	41
29	Cables From EOU To T2.5 Sensor, T5 Probes, and ECU	42
30	Cables From EOU To NL/NH, FVG/CVG/VEN Sensors, and Flame Detector	43
31	Views of EOU Mounting On Engine	44
32	Configuration of Fuel Cooling Hoses	45
33	Sensor Signal Data From Second Engine Ground Test	50
34	Fiber Optic T1 Temperature Sensor	57
35	Fiber Optic T5 Temperature Probe/Harness Assembly	57
36	Combined Fiber Optic - T/C T2.5 Temperature Probe/Cable, Unpackaged	58
37	Packaged T2.5 Temperature Probe Assembly	58
38	Fiber Optic FVG Position Sensor	59
39	Combined Fiber Optic/Potentiometer CVG Position Sensor	59
40	Fiber optic VEN Position Sensor	60
41	Fiber Optic Flame Detector Spacer, Cable, and Detector Assembly	60
42	Fiber Optic NH Speed Sensor	61
43	Fiber Optic NL Sensor and Cable Pigtail	61
44	WDM Source Board	62
45	WDM Optics Receiver Board	62
46	WDM Electrical Receiver Board	63
47	Electro-Optics Board For Optical NL Sensor	63
48	Electro-Optics Board For Optical NH Sensor	64

LIST OF ILLUSTRATIONS (Continued)

Figure		Page
49	Electro-Optics Board For TRD Sensor	64
50	Data Acquisition (DAC) Board	65
51	GE Power Supply and Electrical Sensor Signal Conditioning Modules	65
52	Conax T5 Sensor Signal Processing Board Assembly	66
53	G&H Expanded Beam Fiber Optic Terminus Assemblies For Routing Through Backplane	66
54	SEM-E Board Connectors With Fiber Optic Cavities For G&H Termini	67
55	Machined Inserts For Support of G&H Termini In Backplane	67
56	EOU Chassis (Engine Side) and Covers	67
57	Side of EOU Chassis Showing Cavities For Module/Board Installation	69
58	RTD For Internal EOU Temperature Measurement	69
59	EOU Assembly With Side Cover Removed	70
60	EOU Assembly With Bottom Cover Removed	71
61	EOU-J88 To ECU-J61 Electrical Cable	72
62	EOU-J89 Cable For Transmission of MIL-C-1553 Data	72
63	EOU-J90 Cable For Supplying 28 VDC Power	73
64	NL Sensor Y Jumper Cable	73
65	Modified F404 CIT Transmitter For Fiber Optic T2.5 Probe Installation	74
66	Modified F404 Alternator Stator For Installation of Fiber Optic NH Sensor	74
67	Mounting of Fiber Optic FVG Position Sensor Onto F404 FVG Servovalve Block	75
68	Linkage Attaching Rod of Fiber Optic FVG Sensor To F404 FVG Actuator Piston	75
69	Installation of Fiber Optic CVG Position Sensor At CVG Actuation Pivot Stud	76
70	Installation of VEN Fiber Optic Position Sensor On Engine AB Case	76
71	Installation of Fiber Optic AB Flame Detector Spacer	77
72	Aft-Looking-Forward View of EOU Mounted On the F404 Engine	77

LIST OF ILLUSTRATIONS (Concluded)

Figure		Page
73	Front View of FOCSI Engine At First Ground Test	78
74	Rear View of FOCSI Engine At First Ground Test; See EOU Just Under Crossbeam	79

TABLES

Table		Page
1	EOU Chassis Connectors	31

1.0 SUMMARY

The overall objective of this program was to develop a prototype set of fiber optic sensing system components capable of being demonstrated in a passive (non-controlling) mode on an engine of a F-18 aircraft during flight. This design and testing program, and continuing through the flight testing, will result in helping to validate fiber optic technology at the component level, providing engine installation and maintenance experience associated with fiber optic components, and evaluating their performance under flight environment.

The measuring of nine sensed parameters on the F404-400 augmented turbofan engine, three air/gas temperatures, three actuation geometry positions, two rotor speeds, and flame presence were chosen for demonstration, using eight different fiber optic sensing techniques. Technology at the advanced prototype level was combined with some critical component development, and packaged for engine installation. Preliminary and critical design reviews through the GE Aircraft Engine Chief Engineer's Office were conducted. Details of each sensor's design, functionality, and environmental testing are described in this report.

Signal conditioning for the fiber optic sensors was provided by electro-optics architecture consisting of a set of circuit boards and a backplane, resulting in MIL-C-1553 data output from an environmentally-tested, engine-mounted, fuel-cooled chassis assembly, designated the EOU (electro-optics unit). One intent of the design was to emphasize multiplexing and commonality among the various sensing techniques. Fiber optic cables were designed/fabricated to interconnect the EOU with the sensors.

To help evaluate the fiber optic sensing measurement performance, a set of electrical comparison signals were used, mostly provided by the existing engine control system, plus some specially added sensors. A goal was for the fiber optic sensing measurements to exhibit performance equal to or better than the electrical sensors under engine operating conditions. Performance levels achieved are described in this report.

The fiber optic sensors, cables, and the EOU were designed to mount onto a F-18 installed F404-400 engine. NASA Dryden Research Center conducted flight test experiments and modifications were made to insure several close clearances between the engine and the airframe were sufficient. The fiber optic sensing system was also designed to minimally interfere with the existing engine control system. GE and NASA flight readiness reviews were conducted to resolve safety issues. Added component mounting brackets were tested for engine resonant frequencies, and some were instrumented during the second of two engine ground tests at GE Flight Test Operation, Edwards, CA.

From the development levels achieved in this program, it is apparent that the temperature capabilities of optical sources/detectors must be improved in order to provide adequate measurement performance. Comparison sensor tests have shown that the proper level of component interchangeability in most cases is lacking. The epoxies used as a fastening technique in many optical assemblies need more temperature design margin. Also, techniques for integrating some low signal level electro-optic circuitry with other electronic signal processing circuitry without introducing unacceptable noise levels are needed. Other lessons learned are included in this report.

2.0 INTRODUCTION

Advanced aircraft propulsion control systems must meet increasingly challenging performance requirements and endure more severe environmental conditions. Commercial goals include reduction in cost and system simplification. Military goals are directed toward high thrust/weight ratios that require higher cycle temperatures to improve thermodynamic efficiency. Reduced weight is a universal objective.

NASA and DoD have recognized that the use of fiber optic technology will provide immunity to EMI (electromagnetic interference), and higher rates of communication. Weight savings are expected through reduced system conductor count, innovative fiber mounting techniques, and reduced complexity. In addition, fiber optics techniques have the potential of providing better system performance and the capability of withstanding higher environmental temperatures.

Fiber optic components identified for potential use in an aircraft propulsion control system need to be evaluated for performance in the required hostile environment. Components mounted on jet engines must endure severe temperature extremes and thermal cycling, and the stress of mechanical vibration, physical shock, and handling abuse, within an atmosphere contaminated with oils, fuels,

humidity, and EMI.

In 1975, NASA began work to develop fiber optic sensors for use in aircraft propulsion systems. In 1985-86, Phase I of a program called FOCSI (Fiber Optic Control System Integration) was jointly funded by NASA and DoD (ref. 1). This program identified sensor requirements and environments, assessed the status of fiber optic sensor and related component technology, and conceived a total fiber optic, integrated propulsion/flight control system. In 1988, FOCSI Phase II evaluated the electro-optic architecture needed to service the sensors and presented a detailed design of a preferred system configuration (ref. 2).

The purpose of the program described in this report was to design, fabricate, and perform bench, environmental, and engine ground testing of a prototype set of fiber optic sensing system components (sensors, cables, and electro-optic circuitry) that have both commercial and military engine application. The results have made a significant contribution in demonstrating the technology and developing a database on its reliability, maintainability, cost, size, and weight, leading to more fully exploring and exploiting the technology benefits, and determining the areas that need more development towards product application.

3.0 SENSOR SET DESCRIPTION

3.1 IDENTIFICATION AND RANGES

The following nine F404 engine sensing parameters and associated measurement ranges were chosen for demonstration of optical sensor techniques:

- | | |
|--|---------------------|
| 1. Engine Inlet Air Temperature (T1) | -65 to 300°F |
| 2. Compressor Inlet Air Temperature (T2.5) | -65 to 535°F |
| 3. Turbine Exhaust Gas Temperature (T5) | 700 to 1600°F |
| 4. Fan Variable Geometry (FVG) Actuator Position | 2.7 inches stroke |
| 5. Compressor Variable Geometry (CVG) Rotation | 56 degrees rotation |
| 6. Variable Exhaust Nozzle (VEN) Actuator Position | 6.923 inches stroke |
| 7. Low Pressure Rotor Speed (NL) | 2787 to 10683 Hz |
| 8. High Pressure Rotor Speed (NH) | 195 to 4425 Hz |
| 9. Afterburner (AB) Flame Detection | On/Off |

3.2 ENGINE/SYSTEM SCHEMATICS

Figure 1 shows locations of the nine sensors on the F404-400 engine. Figure 2 shows a system schematic.

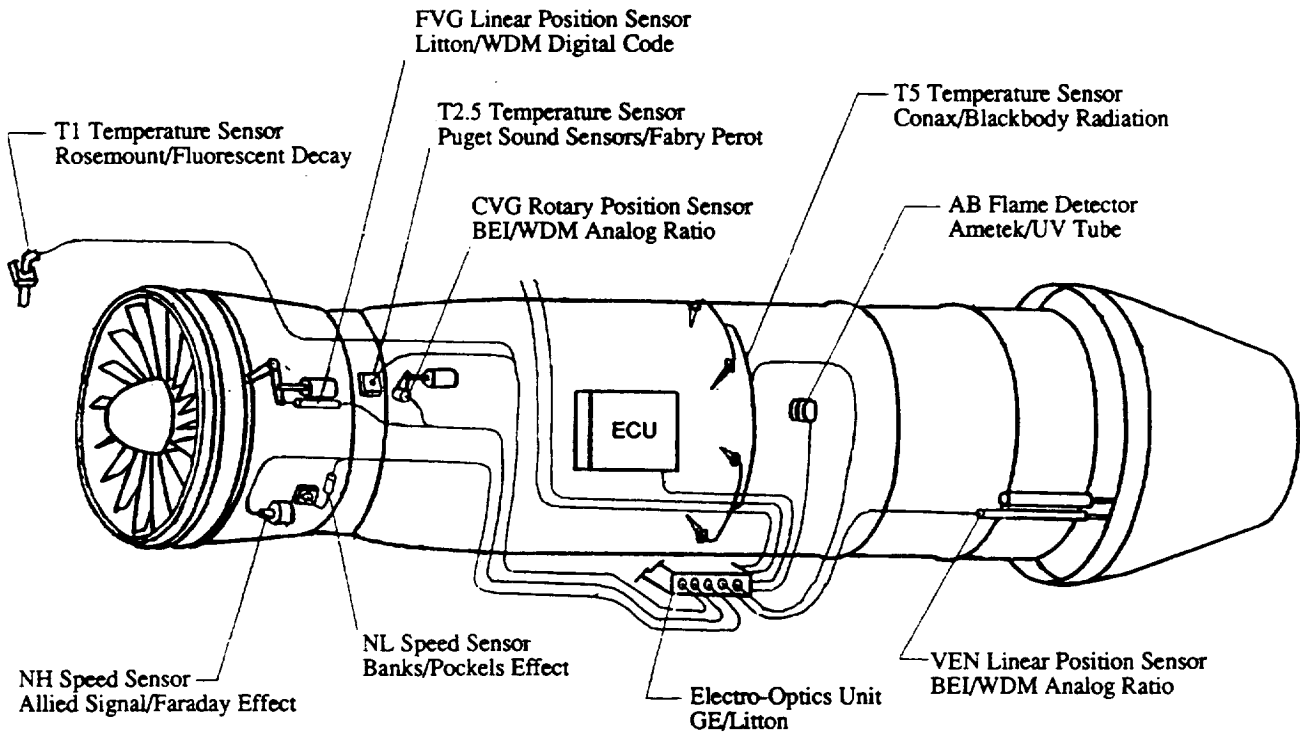

Figure 1 - FOCSI Fiber Optic Sensors On the F404-400 Engine

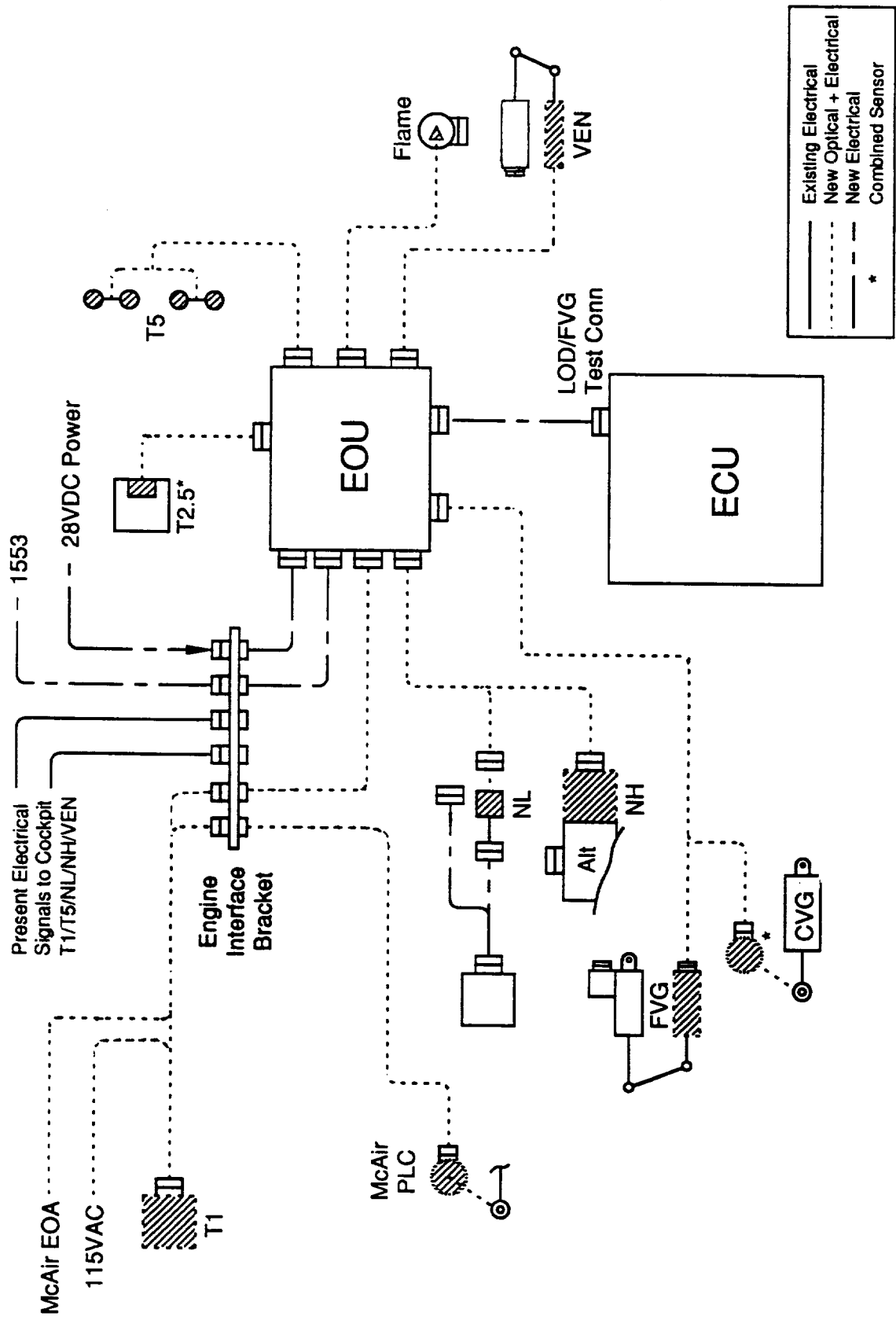

Figure 2 - FOC SI System Schematic

3.3 F404 IMPLEMENTATION

NASA's desire was to demonstrate as full a complement of fiber optic sensors as possible, with minimal interference with the F404 engine or its control system. It was agreed that modifications to the flight critical main fuel control to measure fuel metering valve position would be too complex and costly. No special concerns were associated with implementing FVG, CVG, and VEN positions sensors, T1 and T5 temperature sensors, or NH speed. However, implementing T2.5 temperature, NL speed, and AB flame detection were estimated to be more difficult.

3.3.1 T1 Temperature Sensor

The F404-400 engine control system uses a single element RTD electrical sensor, de-iced using hot air, mounted through the engine front frame. It was not practical to modify the engine frame for the mounting of an additional sensor. It was estimated to also be costly and mechanically difficult to modify the present electrical sensor to add an optical element and substantiate for flight testing.

The option chosen was to modify another qualified inlet-type sensor housing by replacing the electrical element with an optical element, and mount the additional sensor through an additional penetration in the airframe's engine intake, as shown in Figure 3. This model uses has electrical de-icing.

3.3.2 T2.5 Temperature Sensor

The F404-400 engine control system uses a single transmitter mounted through the engine main frame which sends a pneumatic signal, representing compressor inlet air temperature, to the MFC. As with the T1 sensor, it was not practical to modify the engine frame for an additional sensor mounting.

After trading off alternatives, it was decided to install the optical probe through the mounting flange of the F404 pneumatic sensor, clamped in place using a Swagelok device, as shown in Figure 4. A similar modification had been accomplished and flown in the past using thermocouple instrumentation.

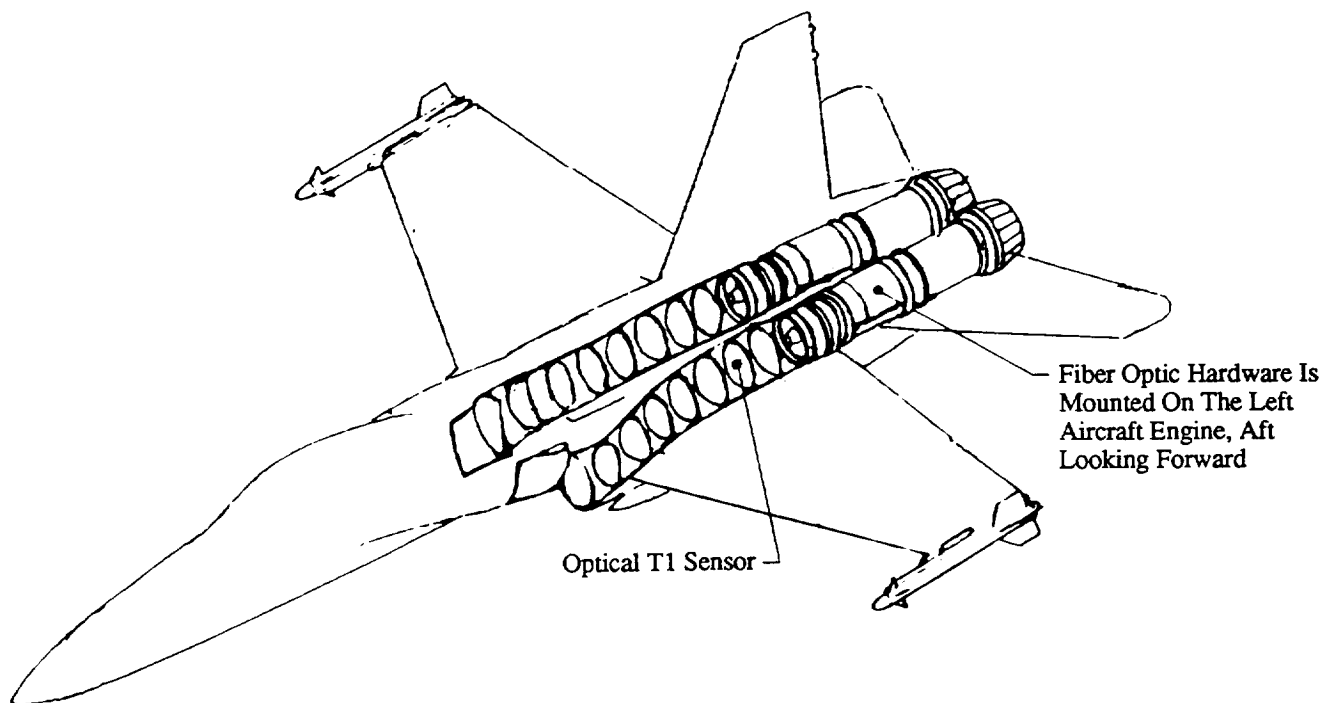

Figure 3 - Optical T1 Temperature Sensor Mounts In The Aircraft's Engine Intake

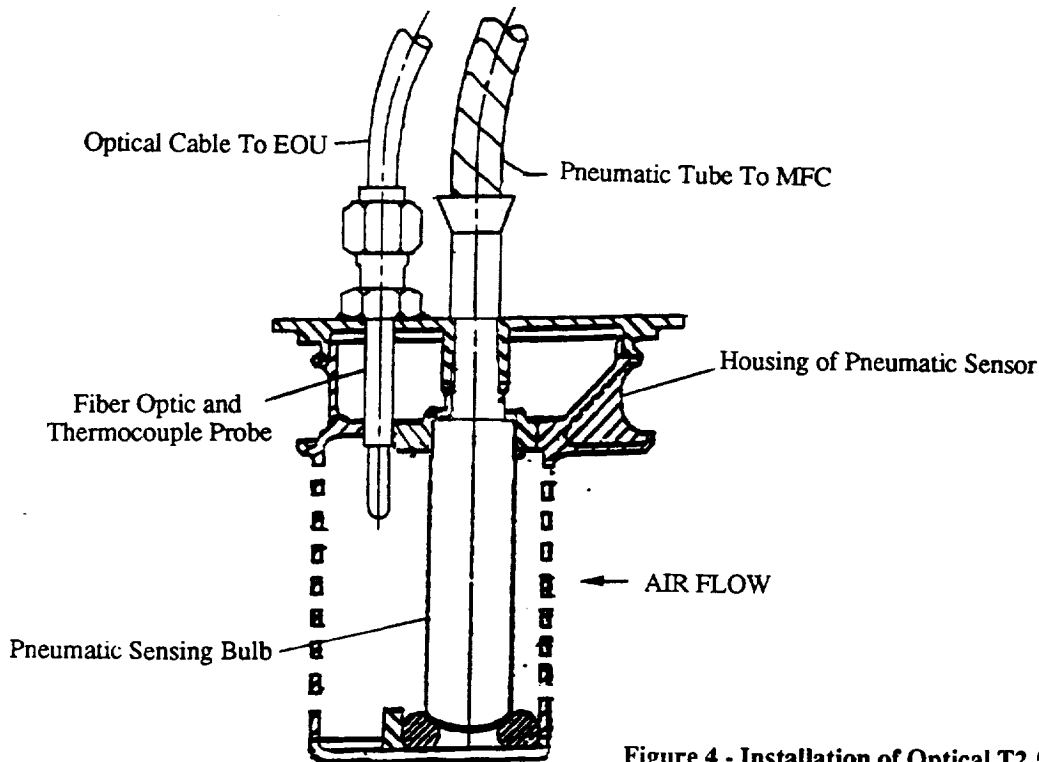

Figure 4 - Installation of Optical T2.5 Temperature Probe Through F404-400 CIT Transmitter Flange

3.3.3 T5 Temperature Sensor

The F404-400 engine control system uses two identical four-probed thermocouple harnesses mounted upper and lower on the AB case. A four-probed fiber optic harness replaces the lower thermocouple harness, as shown in Figure 5. The engine control signal is therefore reduced from an average of eight probes to an average of four probes. The resulting error is not expected to be significant.

3.3.4 FVG Position Sensor

The F404-400 engine control system uses a single electrical LVDT position sensor mounted inside the FVG actuator. A linear optical position sensor was mounted parallel with and external to the FVG actuator. At this location the optical sensor would not be subjected to fluid immersion. Details of this and other sensor installations are described in Section 8.

3.3.5 CVG Position Sensor

The F404-400 engine control system uses a

mechanical link as feedback between the CVG actuator and the MFC. A rotary optical position sensor was mounted to pick off motion of the CVG bellcrank pivot stud.

3.3.6 VEN Position Sensor

The F404-400 engine control system uses a single electrical LVDT position sensor, mounted in a separate housing, in parallel with the VEN actuators. Hydraulic fluid is circulated through the housing for cooling. A linear optical position sensor was mounted parallel with and external to the VEN LVDT and actuators. The optical sensor is not cooled.

3.3.7 NL Speed Sensor

The F404-400 engine control system uses two electrical eddy current speed transmitters mounted on the fan frame to count the titanium fan blade tips. Having both electrical sensors in operation is important for flight safety. By inserting an electrical Y cable, the signal from one electrical speed sensor was branched as input to the optical sensor, as shown in Figure 6.

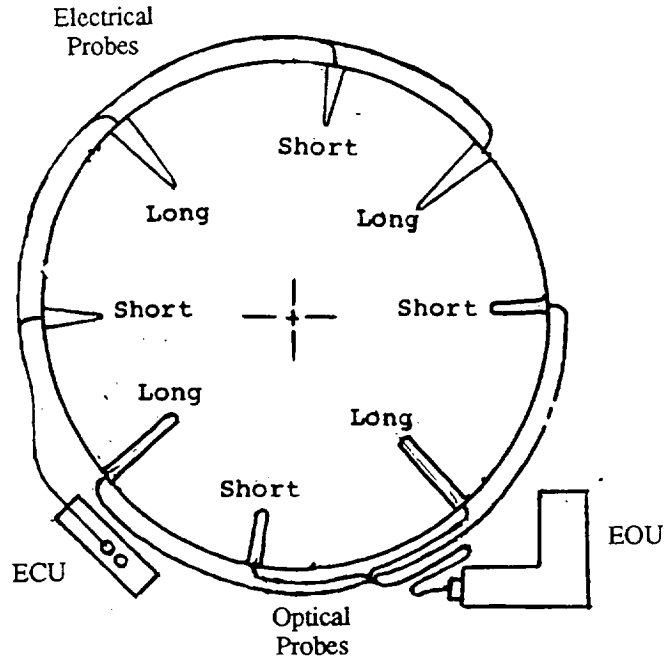

Figure 5 - Aft Looking Forward View Of Electrical and Optical T5 Temperature Probes On F404-400 Engine For FOCSI

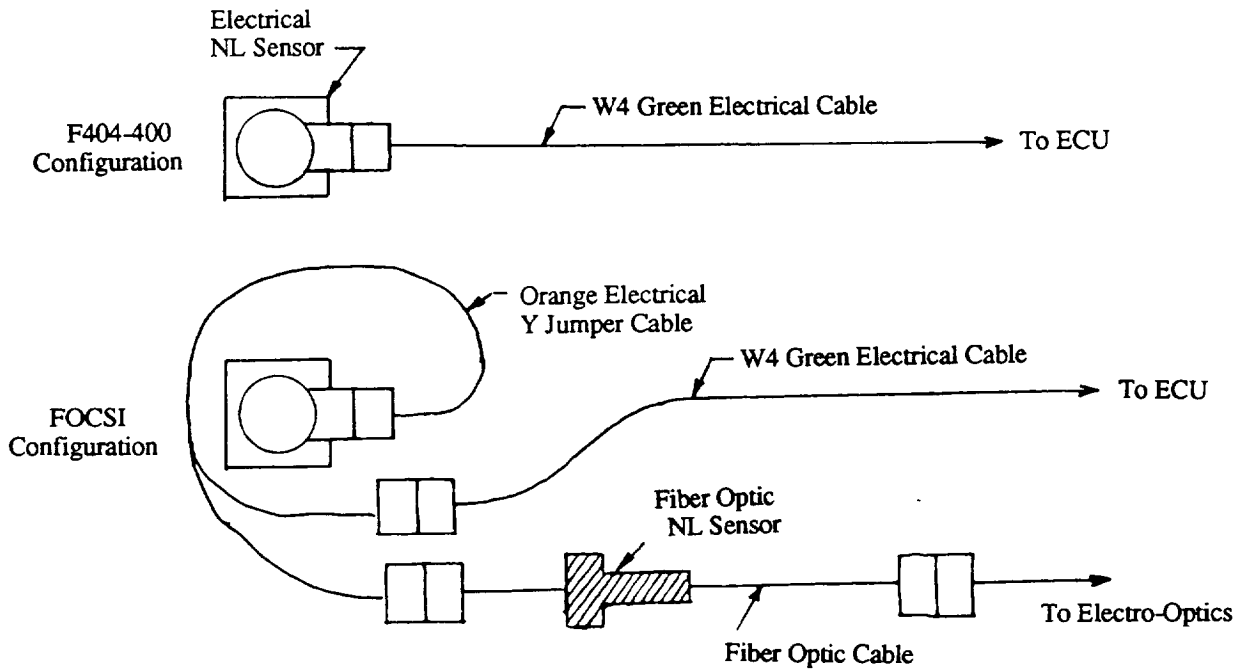

Figure 6 - Fiber Optic NL Speed Sensor Interface With F404-400 NL Speed Sensor

3.3.8 NH Speed Sensor

The F404-400 engine control system includes a gearbox-mounted electrical alternator which provides a NH speed signal by using a separate winding output. The optical speed sensor probe is mounted onto and through a modified alternator stator and is modulated by the magnetic poles of the alternator rotor.

3.3.9 AB Flame Sensor

The F404-400 engine control system uses a single electrical AB flame detector mounted on the AB casing. It was not practical to modify the engine casing and inner liner for an additional sensor mounting. It was decided to insert a spacer between the electrical flame detector and the casing to facilitate tapping off the flame's UV light through a fiber optic bundle, as shown in Figure 7.

3.4 OPTICAL/ELECTRICAL SIGNAL COMPARISON

Provisions were made to compare data from the set of fiber optic sensors with data from the electrical sensors data associated with the F404-400 control system. All nine fiber

optic sensor signals are included on the EOU's MIL-STD-1553 data bus output. The comparison sensor data is obtained in the following way:

Five F404-400 electrical sensor signals, T1 temperature, T5 temperature, NL speed, NH speed, and VEN position, are input to the ECU, then sent off engine for monitoring. During an engine ground test they are continuously monitored. During flight testing, they are part of an aircraft instrumentation interface, monitored in the cockpit, and can be obtained for recording.

Two F404-400 electrical sensor signals, FVG position and AB flame, are input to the ECU and, for this program, are obtained through the ECU test connector and sent to the EOU and included on the MIL-STD-1553 data bus output.

The other two signals, CVG position and T2.5 temperature, have no electrical counterpart in the F404-400 control system. To provide comparison, an electrical potentiometer is included in the CVG fiber optic sensor package. Likewise, a Chromel/Alumel thermocouple is included in the T2.5 fiber optic probe package. Both optical and electrical sensor signals are input to the EOU, processed, and included on the MIL-STD-1553 data bus output.

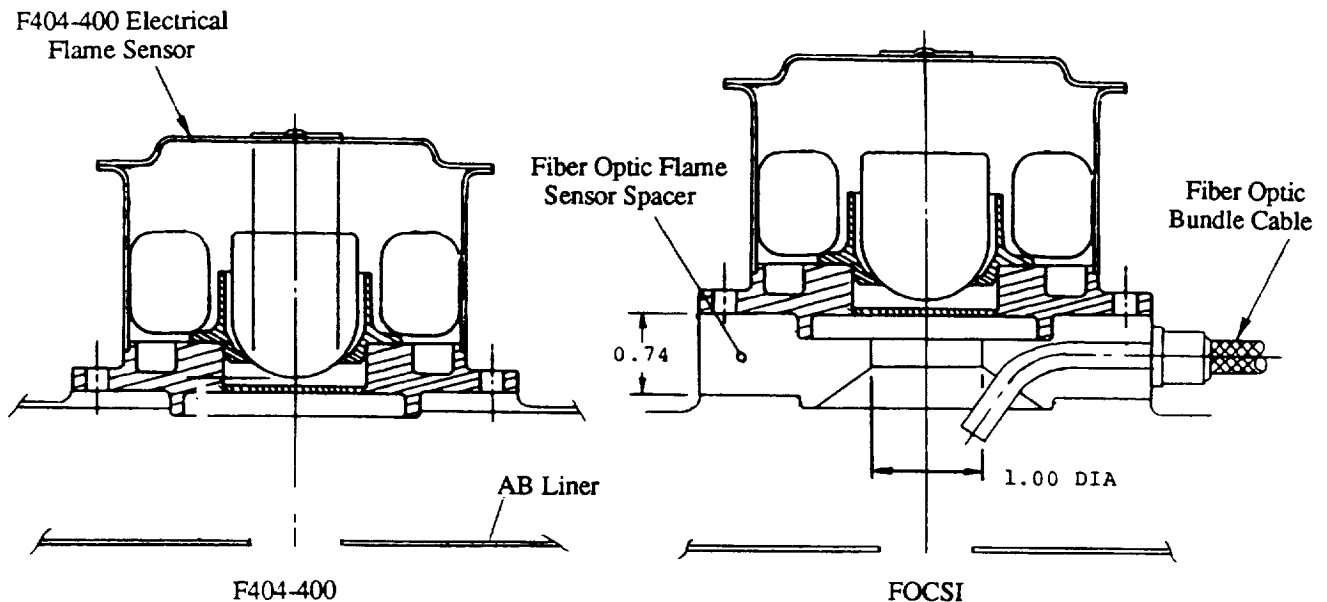

Figure 7 - AB Flame Sensor Configurations

4.0 SENSOR DESIGN, FUNCTIONALITY, & TESTING

Preliminary and critical design reviews were conducted through the GE Aircraft Engines Chief Engineer's Office to examine the intended design implementation, the specified design requirements, and the resulting design details of each sensing component for compliance with acceptable design practices and procedures. Issues commonly requiring corrective action included those associated with materials, fastening techniques, stress concentration, sealing against contamination, installation clearances, operation in the engine's temperature and vibration environment, and interference with the present F404 control system.

4.1 T1 TEMPERATURE SENSOR (ref. 3)

4.1.1 Design

This sensor is identified as Rosemount Aerospace Model 701J1. It was constructed by modifying an already qualified inlet total temperature sensor, Model 154DR3, which has immersion depth and other characteristics similar

to the F404-400 electrical T1 temperature sensor. The sensor housing was basically used intact in order to maintain its design integrity. The electrical connector was replaced with a MIL-C-38999 Series III connector and ITT Cannon fiber optic pin contacts per MIL-T-29504. The sensor uses step index, fused silica fiber with a 200 micron core and a NA of 0.22. An electrical de-icing heater element is included. Figure 8 shows the physical outside features.

The electrical RTD sensing element was replaced with an optical TRD sensing element, capable of sensing temperatures over the range from -65°F to 450°F. Several design modifications were accomplished in the way the new element is supported in the housing.

4.1.2 Functionality

The TRD technique is based on measuring the fluorescent decay time of a material following excitation from an optical source. Light from a transient source (pulsed or sinusoidal) is transmitted through a single optical

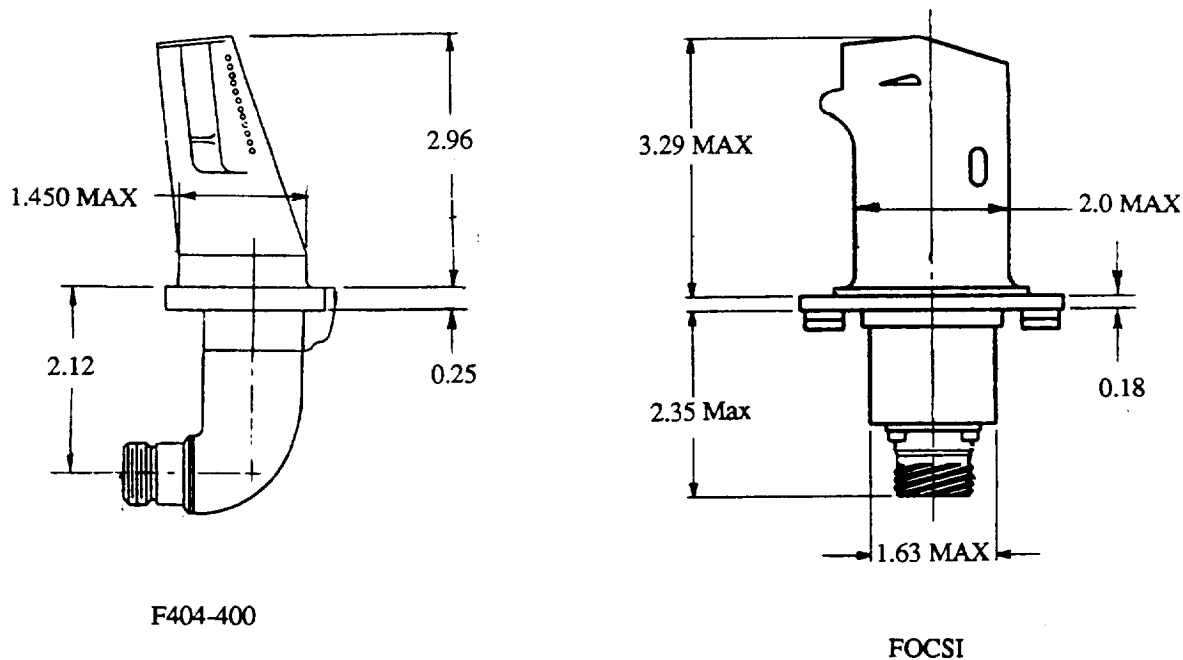

Figure 8 - T1 Temperature Sensor Housing Configurations

fiber to the sensing element, which consists of a fluorescent material attached to the end of the fiber. A dopant ion in the fluorescent material is excited to a higher energy state by absorption of the source signal and correspondingly emits a fluorescent signal, at a different wavelength, into the same fiber. With proper material selection, the fluorescent signal can be modeled as an exponential decay with a decay time that exhibits a temperature dependence. A signal conditioning circuit relates the exponential time constant to a temperature measurement.

TRD temperature measurement is based on intrinsic properties of the fluorescent material. Unlike some other optical temperature sensing techniques, high tolerances and precise alignments are not required in the sensor assembly. Also, being a time based encoding scheme, it is theoretically immune to variable system losses.

4.1.3 Testing

Each of the three fabricated sensors were acceptance tested by Rosemount Aerospace. One of the three sensors was subjected to and passed environmental testing per the requirements associated with the F404-400 T1 temperature sensor. The exception to this was vibration. The housing alone completed vibration testing per F404 requirements. The entire assembly completed vibration testing per the F18 engine intake (where the FOCSI sensor is mounted) requirements, because Rosemount Aerospace was relatively certain that the optical element was not capable of passing engine requirements at this time. Testing description is listed below.

- 100 thermal cycles, -65° to 300°F
- Temperature shock, -65° to 300°F
- Vibration , 5 to 50 Hz, resonance dwells/endurance sweeps and random (per F18)
- Vibration, 20 g's, 100 to 2000 Hz, 50 g's to 4000 Hz, 160 g's to 10 KHz, resonance dwells/endurance sweeps at upper temperature, total of 36 hours (housing only).
- Physical shock, 20 g's, 3 axes
- Humidity, 10 days, 95%, 70° to 160°F

A test cable constructed using ICORE conduit was used in the vibration test to simulate aircraft installation. However, it was also used during the thermal cycling. On the 65th thermal cycle, a low signal level failure occurred. The problem was traced to degradation of the epoxy used with the socket contact in the cable connector. See Section 11, Discussion of Results, for details.

Rosemount Aerospace also completed wind tunnel testing, including temperature recovery error, thermal time response, and de-icing heater error. The data was used to compare a housing containing an optical element with a housing containing an electrical element.

4.2 T2.5 TEMPERATURE SENSOR (ref. 4)

4.2.1 Probe Design

The probe is designed to install into the modified flange of a F404-400 pneumatic sensor and provide both optical and electrical (comparison) measurements. The optical sensor consists of a MetriCor standard sensor chip (0.4 inch x 0.031 inch diameter package) mounted on the fiber tip of Brand-Rex OC-1250 fiber optic cable (100/140, step index, 0.22NA fiber). The electrical sensor consists of 24 gage, Kapton coated, type K thermocouple wire with a welded junction. These two sensing elements were installed into a drilled aluminum alignment plug, and packaged with magnesium oxide powder into a 300 series stainless steel tubing housing by Puget Sound Sensors. The opposite-end threaded interface is designed to mate for sealing with ICORE conduit. The completed probe package is shown in Figure 9.

The probes were supplied to GE with optical fiber and thermocouple wire pigtailed. These were packaged into the cable assembly by GE, which is described in Section 7.0, Cable Design & Fabrication.

4.2.2 Functionality

The fiber optic sensing element is a Fabry Perot interferometer. Internal reflections within an optically resonant cavity result in wavelength dependent reflectivity. The sensing cavity refractive index and length both increase with increasing temperature. This results in a temperature dependent reflection spectra for the sensor which modulates the spectrum of the excitation light source. The returned spectrum can be analyzed and the temperature of the sensor cavity determined.

4.2.3 Testing

Each of the three fabricated probes were tested and calibrated to 572°F. One of the three probes was subjected to and passed the following thermal testing based on the F404-400 CIT transmitter specification:

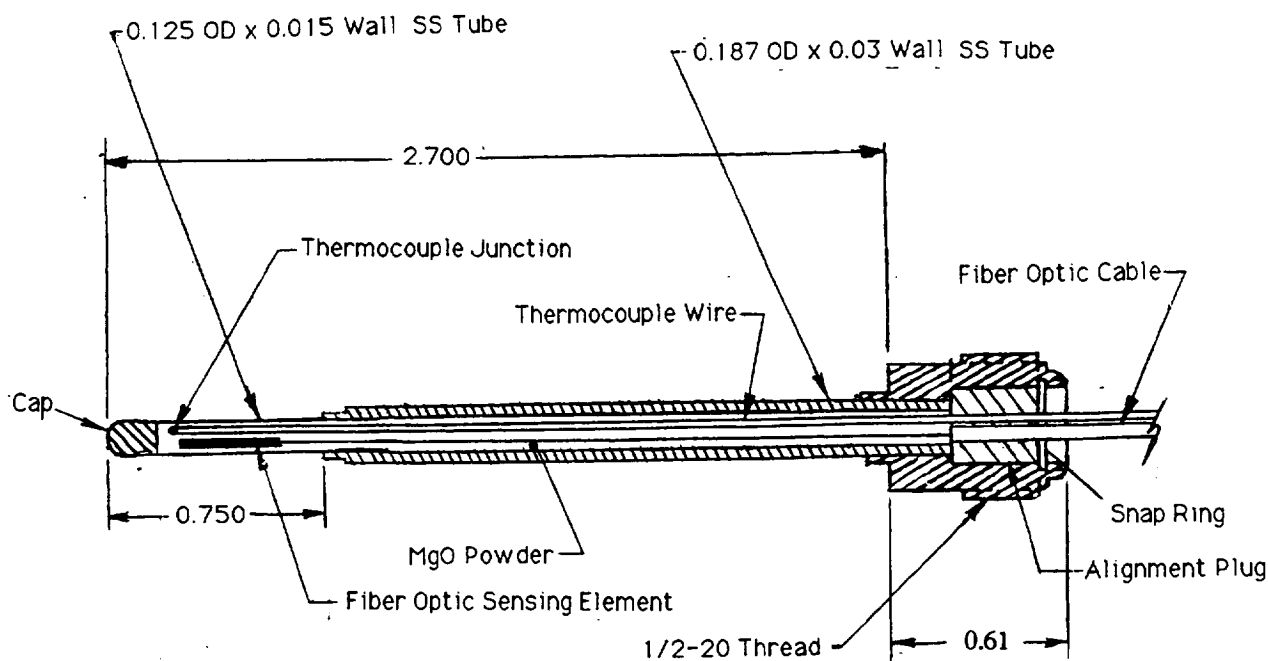

Figure 9 - T2.5 Temperature Probe Package

- 50 thermal cycles, -65° to 535°F (probe tip)
- 50 hour temperature soak, 535°F (probe tip)
- 50 hour temperature soak, 350°F (cable)

As a result of the 50 hour cable soak at 350°F, it was found that the calibration had shifted on the average of 15 to 20°F. This was found to be related to irreversible shrinkage and stickiness of the inner fluoropolymer tubing of the Brand-Rex OC-1250 fiber optic cable. The shrinkage apparently placed the fiber under a constrained shape, made worse by the stickiness, which causes microbend losses and changes in the mode distribution transmitted through the fiber. See Section 11, Discussion of Results, for more details.

A probe was also subjected to vibration testing at GE in a fixture to simulate its engine mounting configuration. This consisted of a resonance survey and 6 hours of sweep cycling from 10 to 2000 Hz, at levels up to 3.2 g's, according to F404-400 vibration levels. The major first flex resonance was found to be above the maximum value of concern for engine operation.

4.3 T5 TEMPERATURE SENSOR (ref. 5)

4.3.1 Design

The design consists of an assembly of four probes (two long and two short) and an optical cable harness. Each probe assembly consists of a sensing element fabricated from a sapphire rod, a ceramic tube for support at the end exposed to combustion gases, and a metal housing with cooling passages over the remaining length. Each probe assembly is joined to the optical cable with a split flange that allows access to the optical components but is not intended to be disassembled in the field. A physical outline of the assembly is shown in Figure 10.

A single 200/220 micron optical fiber, with polyimide buffer and additional jacketing, carries the light from each probe to a special connector. The entire harness uses flexible metal outer conduit.

The probes are designed mechanically to perform in the F404-400 thermal, vibration, and gas flow environment,

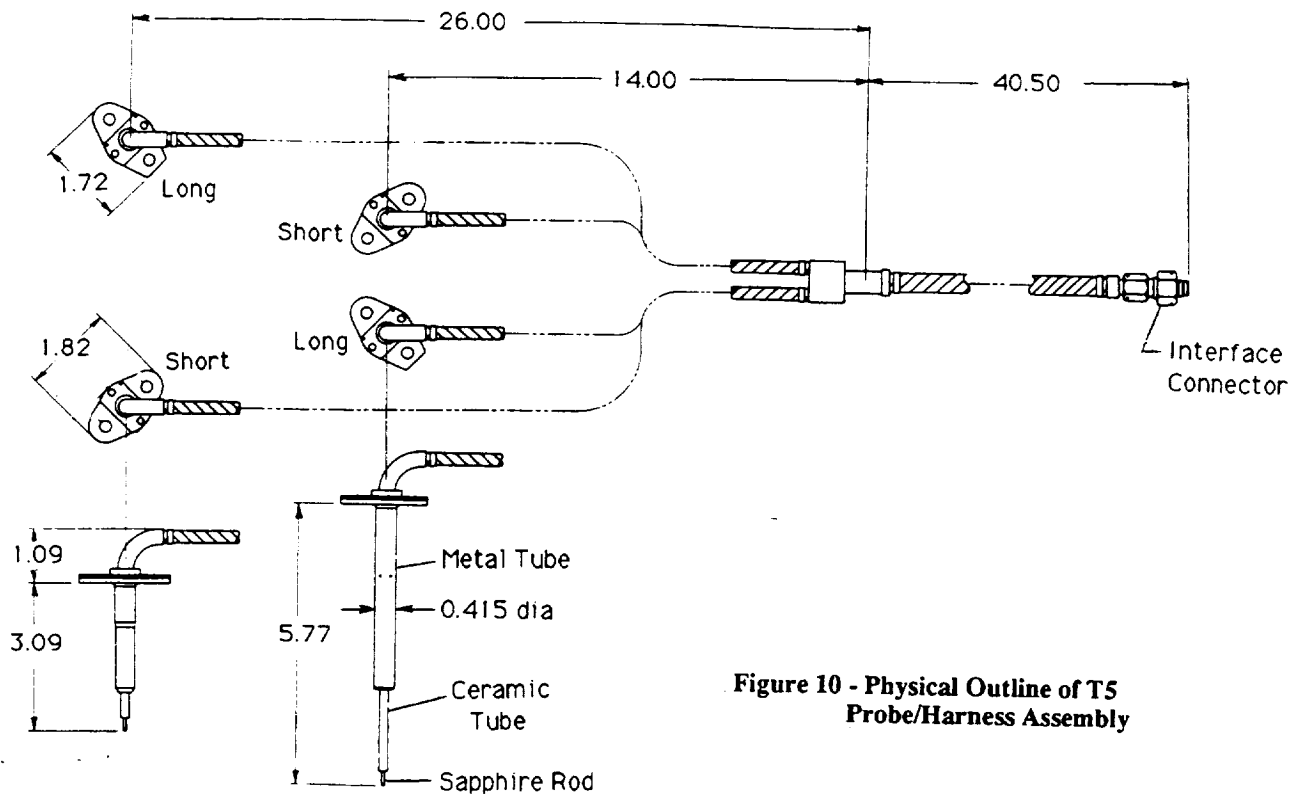

Figure 10 - Physical Outline of T5 Probe/Harness Assembly

but are actually designed to measure temperatures to 2500°F, demonstrating capability beyond the F404 requirements.

4.3.2 Functionality

The sensing principle for this sensor is blackbody radiation. A source material embedded at the end of the sapphire light guide emits radiation varying as a function of temperature. The four probe signals are projected onto a common detector assembly thereby integrating the optical intensity to produce an “optically averaged” signal.

From 700° F to 1100° F, the measurement is based only on the output from a germanium detector in the spectral band from 1000 to 1800 nm. From 1100° F to 2500° F, the measurement is based on the ratio of the output of a germanium detector with the output from a silicon detector in the spectral band from 400 to 1000 nm. In the upper range, being a ratio mode, the measurement is more accurate than in the lower range.

4.3.3 Testing

Three probe/harness assemblies were fabricated by Conax Buffalo. One of the three assemblies was subjected to and passed environmental testing per requirements based on the F404-400 exhaust gas temperature probe/harness assembly. Testing consisted of the following:

- 25 thermal cycles, 200° to 1600° F (probe), -65° to 490° F (harness)
- 24 hour temperature soak, 1500° F (probe), 490° F (harness)
- Vibration, 10 to 2000 Hz, 20 g's, resonance dwells/endurance sweeps
- Humidity, 5 days, 95%, 70° to 167° F.
- 25 hours of simulated aerodynamic loading at 1600°F on the ceramic support tube of the long probe.

4.4 FVG POSITION SENSOR

4.4.1 Design

This sensor is identified as Litton Model FO3575-1. It is a linear position transducer with a ± 1.35 inch optical stroke and 0.25 inches mechanical over-travel at each end. The rod end turnbuckle has ± 0.050 inches of adjustment. Each sensor uses two 100/140, step index, 0.22 NA optical fibers for excitation and return light. Its optical signal interface is a MIL-C-38999 Series III connector using Amphenol fiber optic pin contacts per MIL-T-29504. Its mechanical interface for engine mounting is a flanged/slotted clamp around the circular (1.00 inch diameter) outer body. Figure 11 is an outline drawing.

4.4.2 Functionality

This sensor uses digital wavelength division multiplexing. The sensor shaft is a 12 bit-encoded linearly moving scale. The sensor is excited by a 750 to 900 nm source spectrum through the input fiber. After passing through a coupler, a grin lens, prism, and grating are used to spread the light across the code plate. Reflected light is collected and sent through the output fiber to the electro-optics circuitry for decoding.

4.4.3 Testing

Three sensors were fabricated by Litton Poly-Scientific. One of the three was subjected to and passed environmental testing per requirements based on the F404-400 FVG servo-actuator design specification and vibration data. Testing consisted of the following:

- 25 thermal cycles, -65° to 300° F.
- 24 hour temperature soak, 300° F
- Vibration , 10 to 2000 Hz, up to 3.2 g's, resonance dwells/endurance sweeps, total of 18 hours.
- Physical shock, 20 g's, 3 axes
- Humidity, 5 days, 95%, 70° to 130° F
- 50 hours of rod extend/retract endurance, 10 cycles/minute

After the testing, it was determined that a significant shift in the position of the sensor in its body clamp would be required for rigging on the engine, invalidating the resonance testing at Litton. However, frequency (ping) testing by GE FTO, Edwards, following the first engine

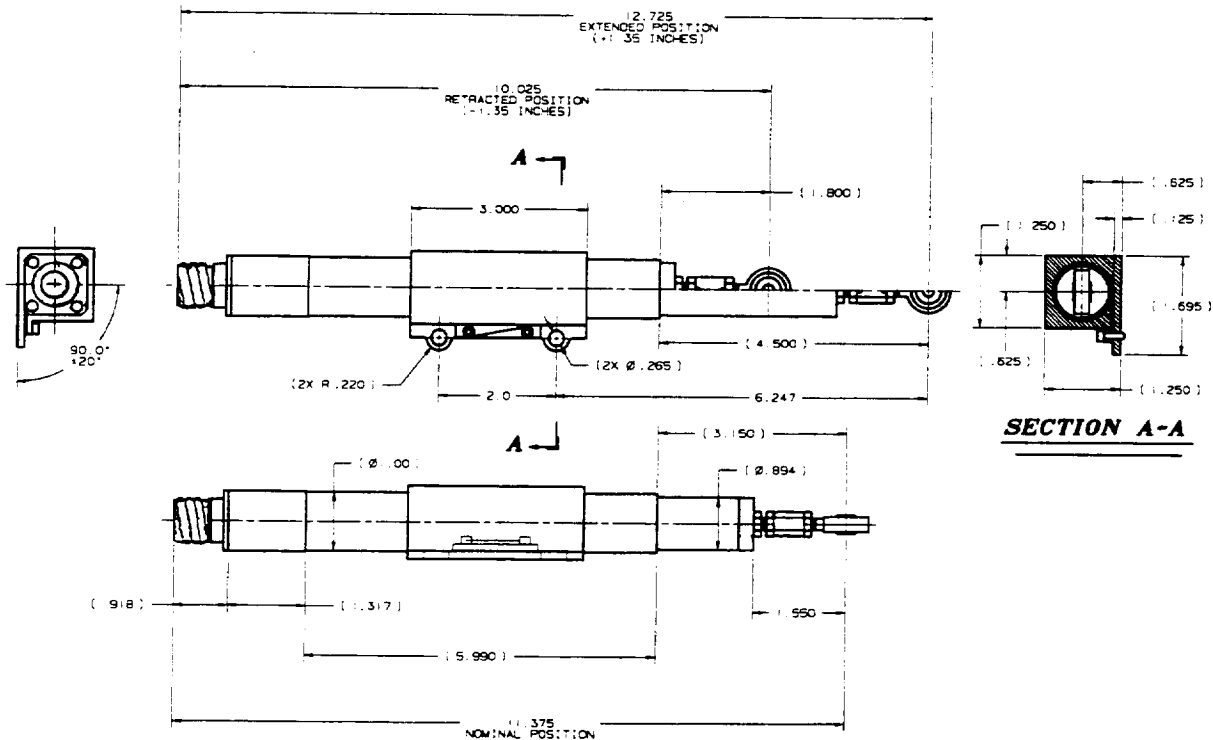

Figure 11 - Outline Drawing of FVG Position Sensor

ground test, showed that as mounted/rigged on the engine, there were no severe resonances in the engine operating range. During the second engine ground test, the sensor was monitored for vibration. See Section 10.2, Second Engine Test, for the results.

4.5 CVG POSITION SENSOR (ref. 6)

4.5.1 Design

This sensor is identified as BEI Model 90023. It is a rotary position transducer with 56 degrees of calibrated shaft rotation, but capable of 360 degrees of mechanical shaft rotation. The housing contains both an optical sensing device and an electrical potentiometer to provide a comparison signal. Figure 12 is an outline drawing. Each sensor uses two 100/140, step index, 0.22 NA optical fibers for excitation and return light. Its signal interface is a MIL-C-38999 Series III connector using Amphenol fiber optic pin contacts per MIL-T-29504.

4.5.2 Functionality

This sensor uses an analog wavelength ratiometric technique. The sensor is excited by light through the input fiber centered over the wavelengths of 780 nm and 880 nm. In the sensor, a coupler splits the light into two equal intensity branches. The light in each branch is collimated, directed through a code plate, and respectively filtered. One path is through a variable transmittance track on the code plate, the other is through a constant transmittance track. The outputs are coupled into the output fiber. The light is split and filtered again in the electro-optics circuitry and the 780/880 nm intensity ratio is a measure of rotary position.

4.5.3 Testing

Three sensors were fabricated by BEI Motion Systems. One of the three was subjected to and passed (see comment on vibration below) environmental testing based on the F404-400 FVG servo-actuator design specification

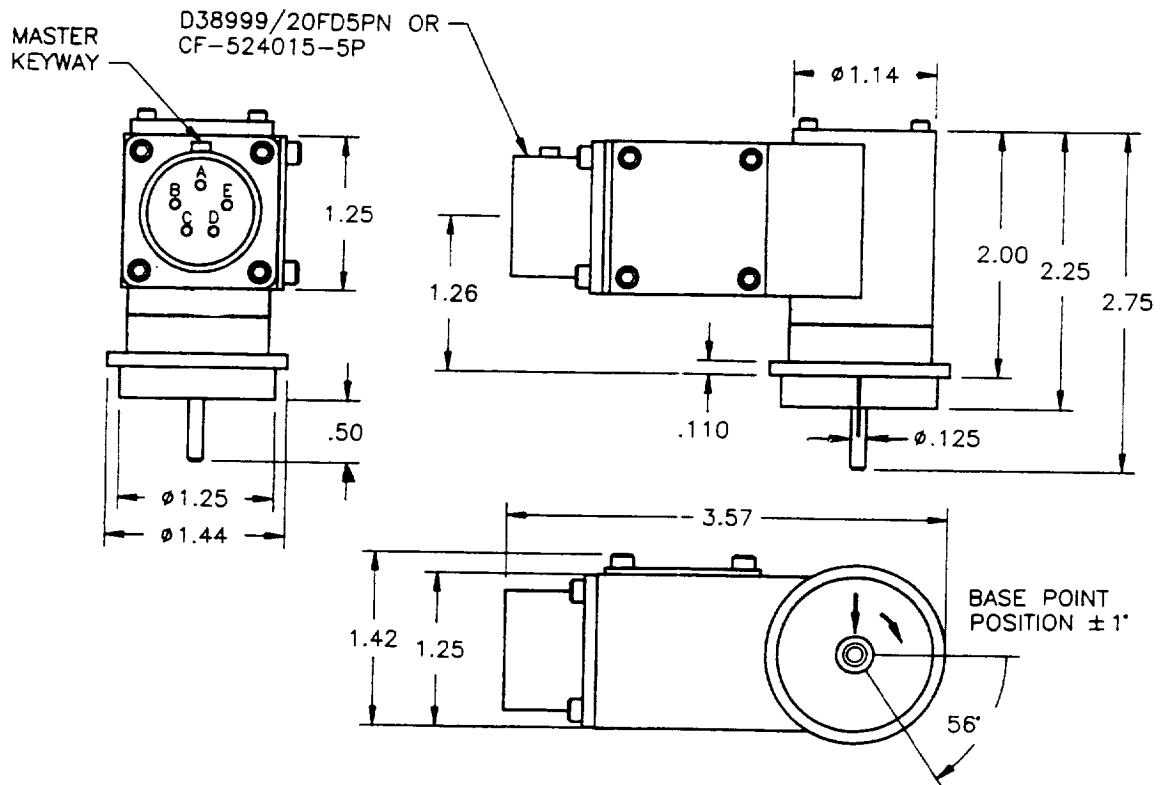

Figure 12 - Outline Drawing of CVG Position Sensor

and vibration data. Testing consisted of the following:

- 25 thermal cycles, -65° to 350° F.
- 24 hour temperature soak, 350° F
- Vibration , 10 to 2000 Hz, up to 3.2 g's, resonance dwells/endurance sweeps, total of 22 hours.
- Physical shock, 20 g's, 3 axes
- Humidity, 5 days, 95%, 70° to 130° F
- 50 hours of ± 60 degree shaft cyclic endurance, 10 cycles/minute

During the vibration testing, no sensor failure occurred. However, the flexible shaft coupling failed twice. BEI included an additional bracket to the engine mounting simulated setup for stiffening and stability. This invalidated the resonance testing because it no longer represented the engine configuration. However, bracket modifications were made for engine mounting and frequency (ping) testing was performed as mounted on the engine. The results are described in Section 8.1, Sensor Installations.

4.6 VEN POSITION SENSOR (ref. 6)

4.6.1 Design

This sensor is identified as BEI Model 90027. It is a linear position transducer with a ± 3.50 inch optical stroke and mechanical overstroke. Figure 13 is an outline drawing. Like the FVG and CVG sensors, each sensor uses two 100/140, step index, 0.22 NA optical fibers for excitation and return light. Its signal interface is a MIL-C-38999 Series III connector using Amphenol fiber optic pin contacts per MIL-T-29504, at the end of a 90 inch fiber optic harness pigtail .

4.6.2 Functionality

This sensor uses an analog wavelength ratiometric technique, identical to that used by the CVG sensor except linear stroke rather than rotary.

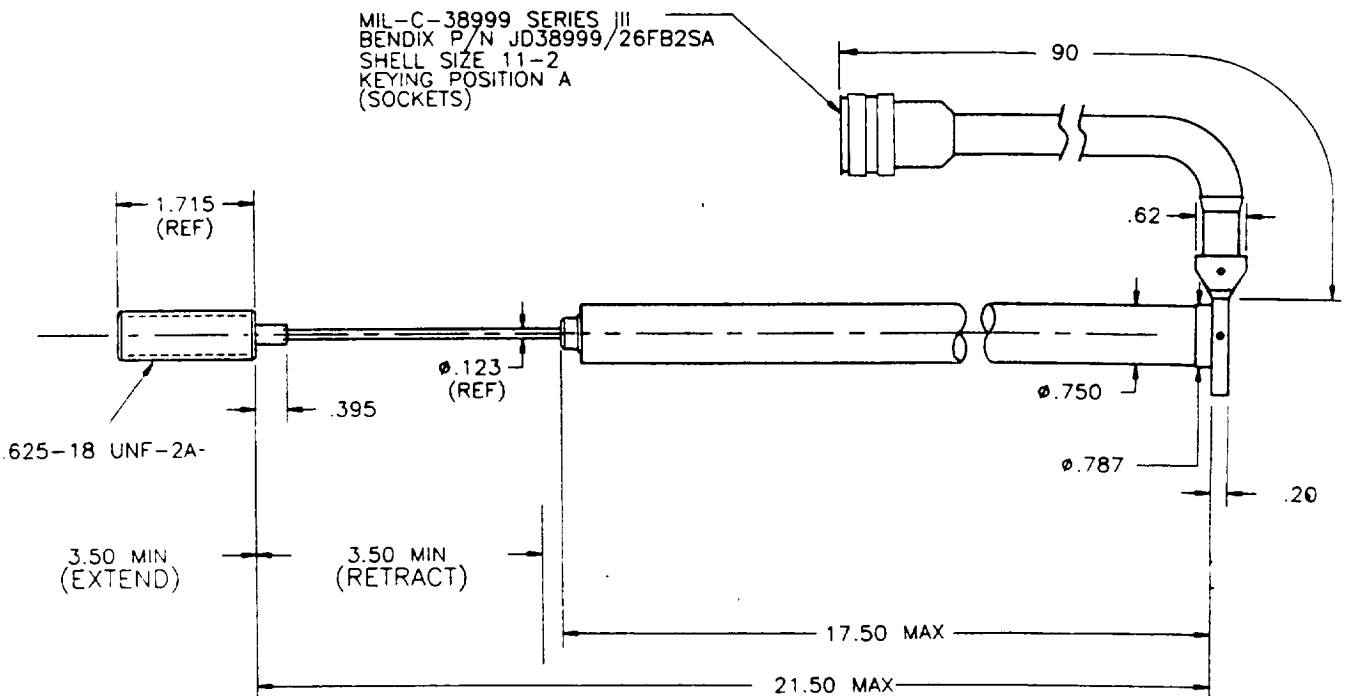

Figure 13 - Outline Drawing of VEN Position Sensor

4.6.3 Testing

Three sensors were fabricated by BEI Motion Systems. One of the three was subjected to and passed (see comment on vibration below) environmental testing based on the F404-400 electrical VEN position transducer design specification and vibration data. Testing consisted of the following:

- 25 thermal cycles, -65° to 350° F, and periodically to 500° F at the sensor rod end
- 24 hour temperature soak, 350° F
- Vibration, 10 to 2000 Hz, up to 3.2 g's, resonance dwells/endurance sweeps, total of 25 hours.
- Physical shock, 20 g's, 3 axes
- Humidity, 5 days, 95%, 70° to 130° F
- 50 hours of extend/retract cyclic endurance, 12 cycles/minute

During the vibration testing, no sensor failure occurred. However, the main bracket intended for engine mounting was braced in such a way to prevent excessive displacement which invalidated the resonance testing because it no longer represented the engine configuration. However, the brackets actually used for actual engine

mounting were significantly different anyway. Frequency (ping) testing was performed as mounted on the engine as described in Section 8.1, Sensor Installations.

4.7 NL SPEED SENSOR

4.7.1 Design

The sensor modulator assembly is encapsulated within a nickel-plated aluminum housing, as shown in Figure 14. At one end of the assembly, the single input/output fiber pigtail (Brand-Rex OC-1260 cable, 100/140 graded index fiber, 0.29 NA) is aligned with the polarizer/lens/crystal elements. The housing includes threads compatible with the coupling nut on an 8 inch long branch of ICORE conduit. The other end of the branch is terminated with a MIL-C-38999 connector used with an Amphenol fiber optic pin contact per MIL-T-29504.

At the other end of the assembly is a shielded electrical pigtail/endcap assembly, fabricated by GE at Ft. Wayne, IN. The pigtail connector is chosen to mate with the orange electrical Y cable from a F404-400 electrical NL sensor, as shown in Figure 6. The wires feed through the sensor endcap and are soldered to the primary wires of a 5:1

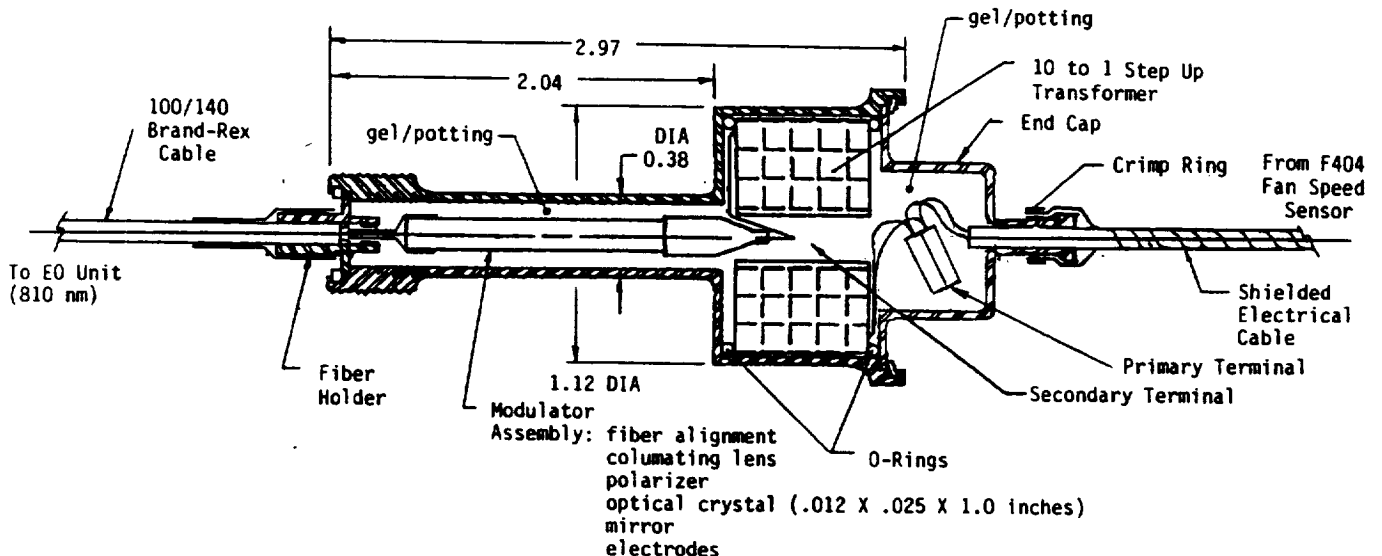

Figure 14 - NL Speed Sensor Assembly

step-up impedance matching transformer (Harder Co. Inc., Part No. 10-0887) used to boost the signal. The transformer secondary wires are silver epoxied to the crystal.

The crystal is suspended in RTV inside the modulator assembly (0.145 inches diameter X 1.49 inches long). The modulator assembly, in turn, is potted into the housing for resistance to humidity and vibration.

4.7.2 Functionality (ref. 7)

The sensing element is an electro-optic (Pockels effect) modulator or shutter. The input light (810 nm) is collimated, polarized, and passed through the modulator material, which rotates the beam polarization in response to the varying voltage signal, imposed on the modulator through electrodes. A mirror at the end of the modulator reflects the light back through the system and it is refocused into the fiber. Estimated optical insertion loss is 34 dB with modulation depths as low as 0.06 dB.

Input voltages from the F404-400 NL sensor to the transformer are estimated to vary from 2 volts peak-to-peak at 2.8 KHz (one/fan blade frequency at 30% engine speed) to 6 volts peak-to-peak at 10.7 KHz (one/fan blade frequency at 115% engine speed). The EO modulator is functional with inputs as low as 0.3 volts and up to 40 volts. Since the fan rotor contains 42 blades, the pulse frequency in Hertz from the optical NL sensor is 0.7 X engine fan rotor speed in RPM.

4.7.3 Testing

One of the three sensor assemblies fabricated by Banks Engineering & Labs was subjected to and passed environmental testing based on the F404-400 electrical NL speed sensor design specification. Testing included the following:

- 24 hour temperature soak, 350° F
- 25 thermal cycles, -65° to 350° F
- Vibration , 10 to 2000 Hz, up to 60 g's, resonance dwells/endurance sweeps, total of approximately 11 hours.
- Physical shock, 20 g's, 3 axes

The vibration testing revealed a small assumed piezo-optic signal effect. Provisions were made to filter out these frequencies using the signal conditioning electronics.

4.8 NH SPEED SENSOR (ref. 8)

4.8.1 Design

The sensor is identified as Allied Signal Model No. FXC-311079. Each sensor uses two 100/140, step index, 0.22 NA fibers for excitation and return light. Its signal interface is a housing mounted MIL-C-38999 Series III connector using Amphenol fiber optic pin contacts per MIL-T-29504. The design is temperature limited to 425° F by the active material.

Three o-ring grooves on the mounting face provide sealing around the probe and two bolts entering the alternator stator. A dimensional stackup was done to size the probe length so that there is no chance of interference with the alternator rotor, without the use of shims. The gap will fall between 0.020 mils and 0.090 mils. It will be measured at each installation. Since the mounting bolts install from inside the alternator stator, the sensor body threaded inserts were carefully reviewed for strength and retention. Figure 15 is an outline drawing of the sensor.

4.8.2 Functionality

This is categorized as a Magneto-Optic or Faraday effect sensor. The input light (730 nm) is passed through a linear polarizer, a magneto-optic crystal, and a cross-polarizer. As the magnetic field in the alternator fluctuates, the intensity of the transmitted light is modulated in intensity since the magneto-optic crystal rotates the polarization of the light. The design for this probe lets minimum light through in the unexcited state. The amount of light modulation decreases as temperature increases, but is unaffected by rotor speed. Average measured optical insertion loss is 28 dB, with average modulation depth of 10 dB.

The alternator rotor has 9 magnetic poles. The engine gearbox to engine core speed ratio is 1.59091. Therefore the pulse frequency in Hertz from the NH speed sensor is 0.239 X engine core speed in RPM.

4.8.3 Testing

One of the three sensor assemblies fabricated by Allied Signal was subjected to and passed environmental testing based on the F404-400 electrical alternator design specification. Testing included the following:

- 8 hour temperature soaks, -65° F and 350° F
- 50 thermal cycles, -65° to 350° F
- Vibration , 10 to 2000 Hz, up to 20 g's, resonance dwells/endurance sweeps, total of 13 hours, on an

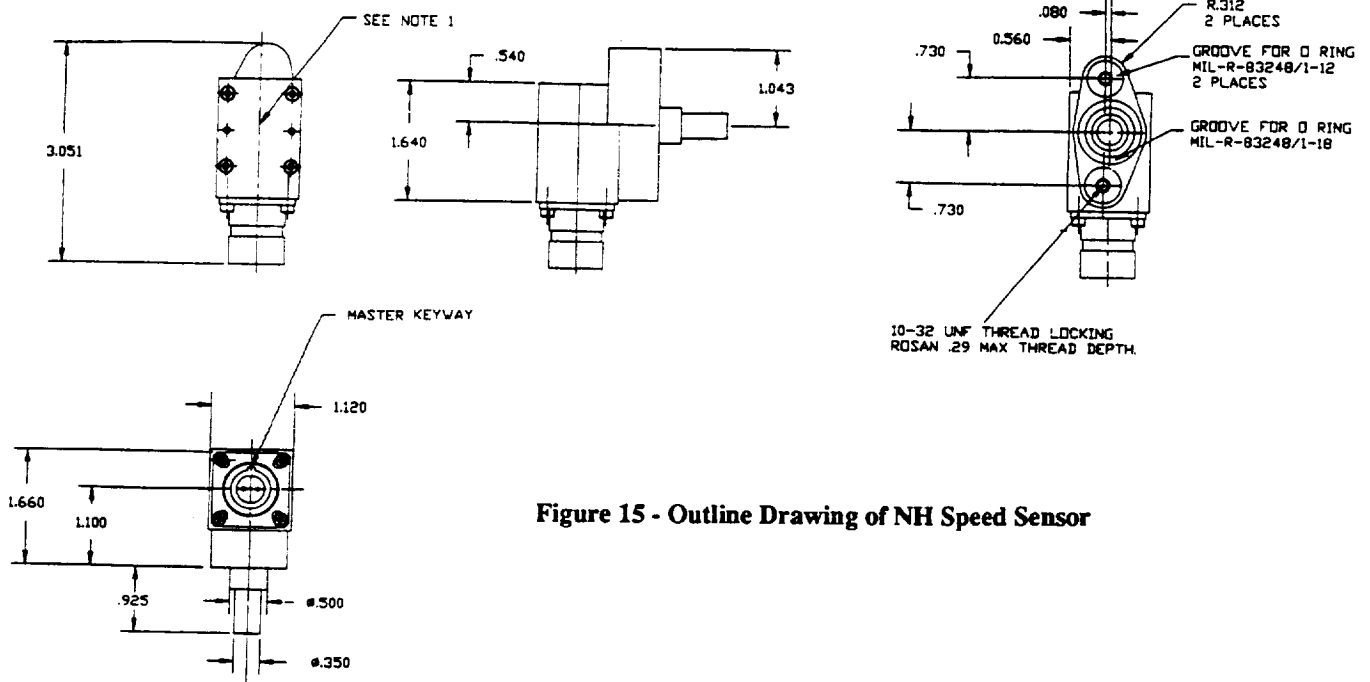

Figure 15 - Outline Drawing of NH Speed Sensor

- alternator rig
- Physical shock, 20 g's, 3 axes
- Humidity, 5 days, 95%, 70° to 195° F

4.9 AB FLAME DETECTOR

4.9.1 Design

The detector assembly components include the following: (1) A stainless steel spacer, installs under the F404-400 electrical flame detector. The original height of 0.74 inches was reduced to 0.50 inches for flight testing. It has three possible places where the fiber optic cable can be installed to view the flame. (2) A 59 inch long, 0.375 inch OD, fiber optic bundle cable, containing approximately 100, 200/220, step index, aluminum-coated fibers. (3) A UV detector circuit board. These are shown in Figure 16. This configuration allows the F404 detector to continue to function simultaneously. In a product design, only a small casing pad would be required for the end of the cable.

4.9.2 Functionality

UV radiance emitted by the AB flame is collected into the fiber bundle and transmitted to the UV detector in the EOU. The operating spectrum is 200 to 270 nm.

4.9.3 Testing

One of the three spacer/cable assemblies fabricated by Ametek Aerospace Products was subjected to and passed environmental testing per appropriate F404-400 component requirements. Testing included the following:

- 24 hour temperature soak, 450° F
- 25 thermal cycles from -67° to 450°F.
- Vibration , 10 to 2000 Hz, up to 20 g's, resonance dwells/endurance sweeps.
- Physical shock, 20 g's, 3 axes
- Humidity, 5 days, 95%, 70° to 167° F

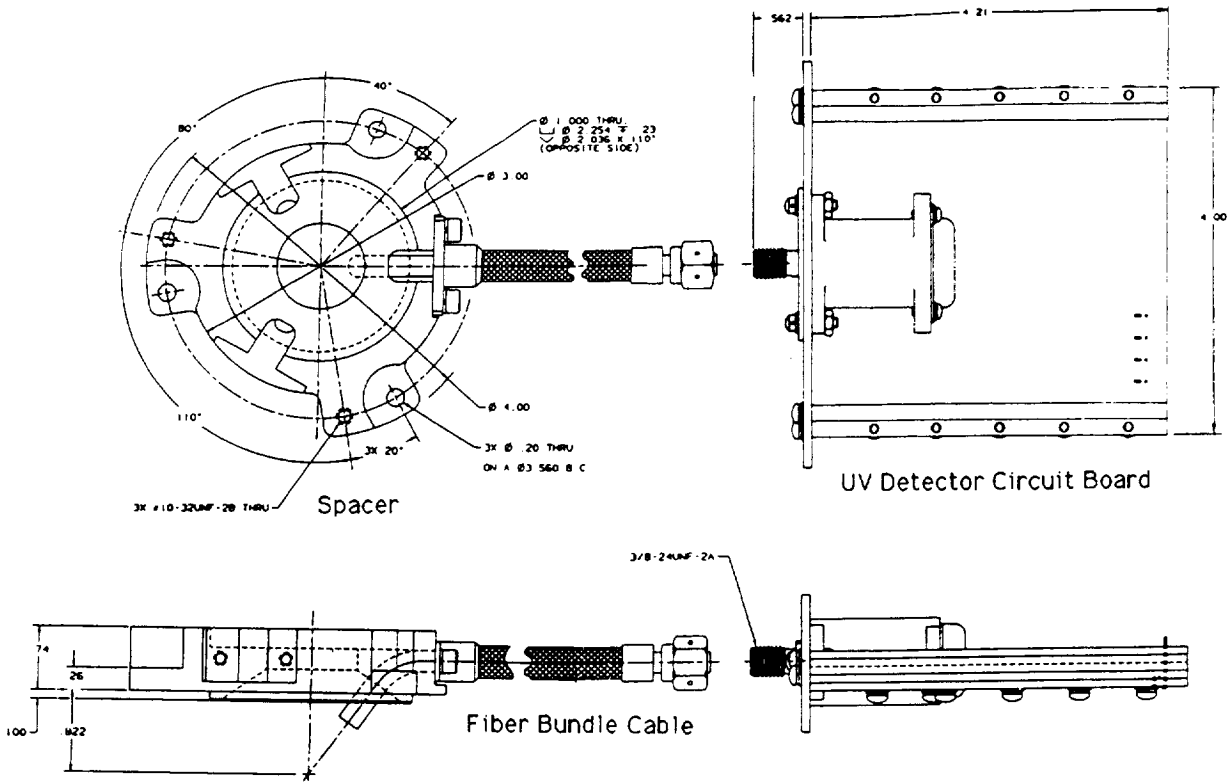

Figure 16 - A8 Flame Detector Components

5.0 ELECTRO-OPTIC CIRCUITRY

As with the sensing components, preliminary and critical design reviews were conducted through the GE Aircraft Engines Chief Engineer's Office to examine the electro-optic circuitry for compliance with acceptable practices and procedures. Issues of discussion focused more on, for example, the thermal environment, installation in the EOU chassis, circuitry packaging, and strain relief than on the specific circuit design itself, because of its often proprietary nature.

5.1 LITTON EOA CIRCUITRY (ref. 9)

Litton fabricated three sets of EO circuitry to service seven (7) of the nine (9) fiber optic sensors (excluding T5 temperature and AB flame). Litton also provided the EOU processor, providing MIL-STD-1553 data output for all nine (9) fiber optic sensors, four (4) electrical comparison sensors, and two (2) internal EOU temperature sensors.

The circuitry consists of eight (8) SEM-E board assemblies and a backplane. The EOA design is largely based on prior WDM sensor interface and data processing designs generated for the McDonnell Douglas FOCSI Program. Each SEM-E board is typically 4 to 10 layers and requires a SEM-E aluminum frame machined such that there is a hole for each component lead. Each board includes high and low frequency decoupling (10 μ F and 0.1 μ F capacitors) at each board edge and throughout the board around critical components.

5.1.1 WDM Source Board

This board contains two broadband ABB Hafo 1A279 LED's and two 770 nm Texas Opto TOX3616-2 LED's to provide a broadband spectrum of 750 to 900 nm to four output channels (FVG, CVG, and VEN position sensors and the T2.5 temperature sensor) that exit via ports on the backplane. One additional channel is fed through an attenuator to the receiver board to provide feedback for fault management and a reference spectrum for WDM analog sensor decoding. The LED duty cycle is varied between 30% and 90% by pulsing a modulator pin, changing the spectral power without affecting the spectral shape. A 5X5 star coupler uniformly mixes the signals into five 100 μ m core output fibers.

5.1.2 WDM Receiver Boards

An optics board and an electrical board comprise the receiver board assembly. The assembly includes the electro-optic interface which converts WDM-based optical sensor outputs into a stream of data which can be processed by digital circuits. It also accepts up to seven additional electrical inputs for processing.

• Optics Receiver Board

The optics receiver board receives return light from the four sensors described below. A WDM coupler focuses each optical signal as a separate row of a two-dimensional CCD array. The pixels in each row divide the spectrum such that there are 1.5 pixels per nanometer of wavelength. One input is routed through an attenuator before it reaches the WDM coupler so that the reference spectrum can be attenuated to a level within the receiver dynamic range.

- For the FVG position sensor, the spectral response is a series of discrete peaks or absence of peaks representing a position on the code plate.
- For the CVG/VEN position sensors, the response is two spectral regions (variable/reference), the energies of which are ratioed to calculate code plate position.
- For the T2.5 temperature sensor, the energy in two regions of the spectral response are used in a difference over sum calculation, and the result is related to temperature through a lookup table.

The CCD is a 192 X 165 pixel array manufactured by Texas Instruments (#TC211). The active area is 2640 μ m² with each pixel measuring 16 μ m by 13.75 μ m. There are no inactive optical zones between the pixels, making this array ideal for high resolution sensing. The array is housed in a ceramic package measuring 0.308 X 0.281 inches.

The output of the CCD array is filtered and level conditioned to match the input requirements of the A/D converter. The A/D converter is a high-speed, 10-bit flash converter capable of digitizing all pixels in the high-speed video stream.

• Electrical Receiver Board

The electrical receiver board converts the four CCD array sensor outputs into unsorted digital data. It also receives analog data from six other sensors. Electrical T2.5

temperature, FVG/CVG position, and flame detector comparison signals, and two internal EOU RTD temperature signals in a 0 to 1.25V analog form are received from the GE A2 module and converted into digital data. An 8X1 analog multiplexer was added to switch between these electrical inputs and the CCD array output so that the one A/D converter could be shared eight ways.

5.1.3 Speed Sensor Boards

There is a separate EO board for both the NL and the NH speed sensors. Each board contains separate LED source/detector/zero-crossing/counting circuitry and presents a digital representation of speed to the DAC board. The LED is kept at a constant bias level for DC operation. The received sine waves are filtered to remove any out-of-band noise, and sent through a comparator to generate square wave TTL signals. The NL board includes a 50/50 coupler to couple transmitted power and the received power into one fiber.

5.1.4 TRD Sensor Board

This board converts the optical output from the TRD sensor into a digital signal that can be read by the 1750 processor and converted to a temperature measurement using a calibration curve. Light at 660 nm is modulated with a 1 KHz sine wave and transmitted through a dichroic coupler into a 200µm core fiber. The sensor fluoresces at 800 nm and returns a signal through the same fiber and dichroic to the photodiode. The phase difference between the transmitted and received signals is used as the data measurement. The phase difference is averaged over eight samples and the result is output to the processor.

Several factors limit the accuracy of the phase technique. When making a time delay measurement, it is highly desirable that both signals have the same amplitude, allowing accurate zero-crossing measurement. As the amplitude differential increases, so does measurement error. The return amplitude from the sensor is sensitive to connector loss and conversion efficiency of the sensor. As a result, the time delay measurement is dependent on the system loss budget.

The TRD board passes both the reference and measured signals through identical 1 KHz active bandpass filters, having a characteristic phase delay through the passband that varies with frequency. The phase delay of the filters adds to the time delay of the sensor and reference signals. Therefore, the differential delay between the filters must be subtracted from the measured delay time for an accurate measurement. Component variations prevent the bandpass filters from being identical resulting in a non-zero differential delay.

Rather than try to measure the differential delay between the filters, the TRD card was calibrated as a unit. The bandpass filters were adjusted for maximum signal response and the delay versus temperature characteristic was measured using a sensor. The result is a calibration model for each TRD board which consists of a third-order polynomial curve fit, residing in the 1750 software.

5.1.5 DAC and Processor Boards

• DAC Board

The data acquisition (DAC) board acts as an elastic buffer between the data from the WDM electrical receiver, speed sensor, and TRD boards, and from the Conax (T5) and Ametek (AB flame) signal processing circuitry and the processor board. It scans all WDM sensor pixels every 10 milliseconds. A state machine uses the clock and row/column information from the receiver to determine which pixels are present at the receiver A/D converter. If the pixel address is one which is required for decoding a particular sensor, the state machine will clock the value of that pixel into the memory. The DAC board also provides power level control to the source board.

• Processor Board

The processor board is a standard SEM-E module that was designed by the Naval Avionics Center. It features a PACE MIL-STD-1750 processor running at 16 MHz, one parallel port interface, and a dual 1553 transceiver. The 14 1553 output words are described as follows:

Word Number	Description	Optical/ Electrical	Range/Units
1	Engine Inlet Temperature (T1)	Optical	-54° to 149° C
2	Compressor Inlet Temperature (T2.5)	Optical	-65° to 540° F
3	Compressor Inlet Temperature (T2.5)	Electrical	0 to 1.25 VDC
4	Exhaust Gas Temperature (T5)	Optical	700° to 2500° F

5	Internal EOU Temperature (T-CCD)	Electrical	0 to 1.25 VDC
6	Internal EOU Temperature (T-Chassis)	Electrical	0 to 1.25 VDC
7	Compressor Variable Geometry (CVG) Position	Optical	-3.5 to 52.5 degrees
8	Compressor Variable Geometry (CVG) Position	Electrical	0 to 1.25 VDC
9	Fan Variable Geometry (FVG) Position	Optical	0 to 2.7 inches
10	Fan Variable Geometry (FVG) Position	Electrical	0 to 1.25 VDC
11	Variable Exhaust Nozzle (VEN) Position	Optical	0 to 6.923 inches
12	Low Pressure Rotor Speed (NL)	Optical	2787 to 10683 Hz
13	High Pressure Rotor Speed (NH)	Optical	195 to 4425 Hz
14	AB Flame	Both	"0" or "1"

5.1.6 Backplane

The EOU backplane is a 10 layer board that routes and supports optical and electrical pathways to, from, and between the eight Litton boards. Each backplane includes the following features:

- Separate solid power planes for each power supply voltage to insure a low impedance connection to each board.

Expanded-beam lensed fiber optic terminus assemblies, for 100/140 fiber, quantity 13, supplied by the Naval Air Warfare Center (NAWC), Indianapolis, IN, from G&H Technology, Inc., Santa Monica CA (see Figure 17). Note, these were not used with the 200/240 TRD sensor fiber.

- SEM-E connectors quantity 5, each with 10 fiber optic cavities (supporting one side of the G&H termini), supplied by NAWC from ITRON Corp., Westmont, IL (see Figure 18).
- Machined inserts, quantity 5 (supporting the other side of the G&H termini), also supplied by NAWC.

5.1.7 Sensor Decoding

Each optical sensor requires a different algorithm for decoding. In addition, the software has to allow for assembly tolerances in the optical DEMUX and the sensors. There was a tradeoff between signal processing ability and the EOU update rate. The total processing time allowed for decoding all the sensors and performing fault

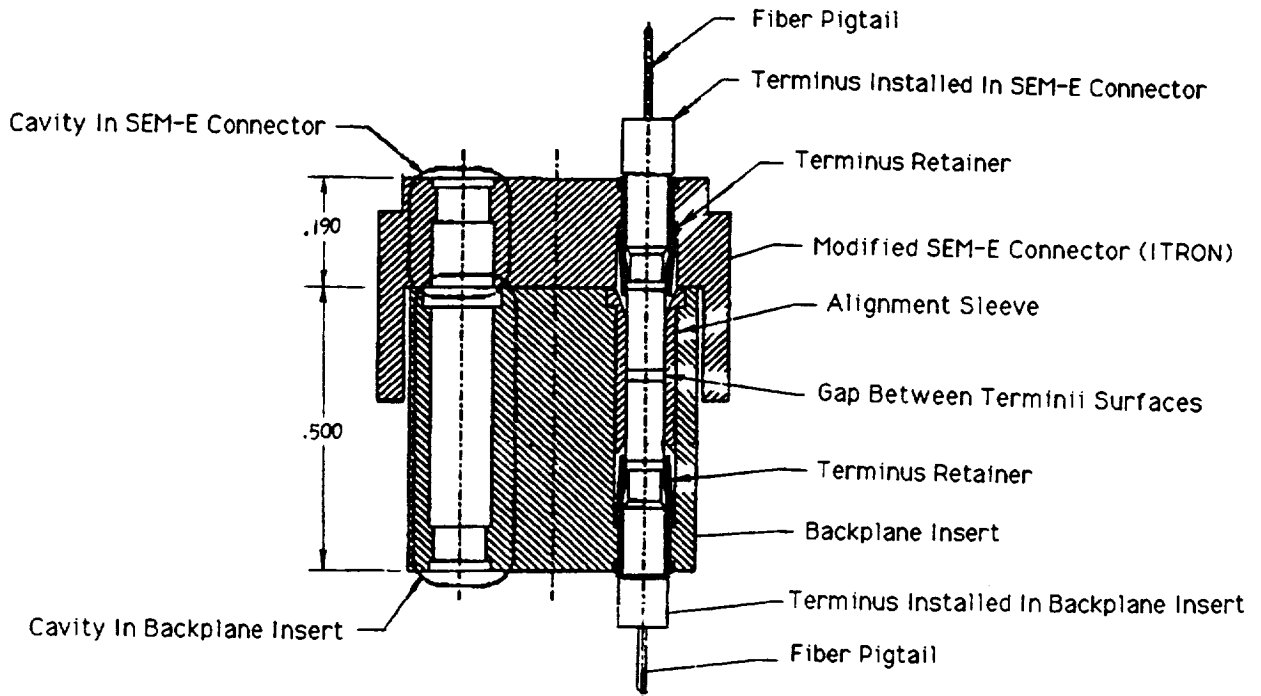

Figure 17 - G&H Fiber Optic Terminus Configuration For EOA Backplane

LITRON SEM-E Connector Modified For Fiber Optics

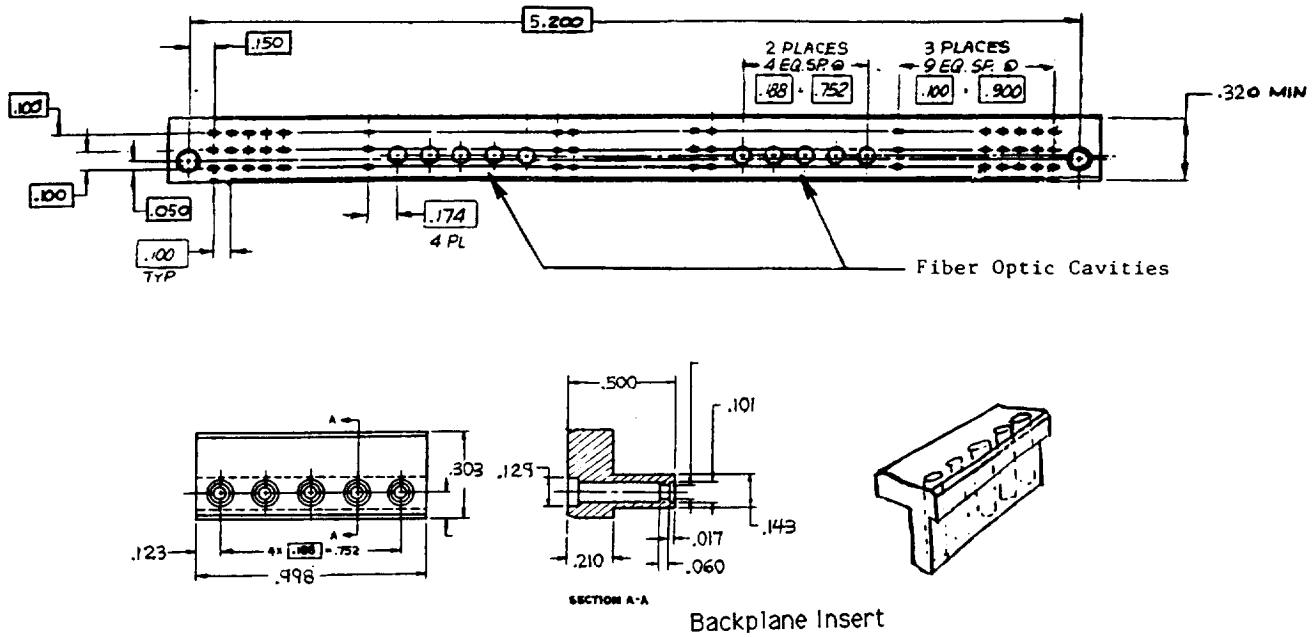

Figure 18 - Modified SEM-E Connector and Backplane Insert For Backplane Fiber Optic Terminus

management must fit within the update rate of the EOU, less the time required to read all pertinent CCD array pixel values. An update rate of 10 ms limited the use of complicated signal processing algorithms.

In general, there are two types of sensors connected to the CCD array: analog and digital. The analog sensors consist of two bands of optical power where one stays constant and the other varies as a function of the sensed value. Since the source spectrum is not completely flat, it has to be subtracted from the received spectrum. This is done by dividing by the feedback channel pixels before any algorithm is applied. The digital sensor requires that the wavelength position of certain peaks be found within the received spectrum

5.1.8 System Optical Power Budget Design

There are four optical systems within the Litton EOA

circuitry: the TRD board and sensor, the NL board and sensor, the NH board and sensor, and the source and receiver boards and their four associated sensors. The insertion losses and dynamic ranges of all sensors had to be compatible with the EOA sensitivity and dynamic range.

5.2 GE CIRCUITRY

5.2.1 Power Supply Modules

GE modules designated A1A and A1B contain the EOU power supply. Each module contains two printed circuit boards. The design uses aircraft 28 VDC power to produce +5 VDC and ±15 VDC. Maximum rated current is about 1.8 amps, resulting in a maximum power consumption of about 50.2 watts. To provide over-temperature protection, the power supply is designed to shut itself off if the EOU internal temperature exceeds 225° F. The power usage breakdown is as follows:

User	Volts	Amps	Power (Watts)
Litton	+ 5	4.110	20.55
	+15	0.286	4.29
	-15	0.427	<u>6.41</u>
			31.25 (total Litton)
GE	+28	0.240	0.67
	+15	0.020	0.30
	-15	0.020	<u>0.30</u>
			1.27 (total GE)
Conax	+ 5	1.500	7.50
	+15	0.025	0.38
	-15	0.010	<u>0.15</u>
			8.03 (total Conax)
Ametek	+15	0.040	0.60 (total Ametek)
			<hr/> 41.15 subtotal Watts
Power Supply Inefficiency Effect (41.15/0.82)			50.18 total Watts

5.2.2 Comparison Sensor Signal Conditioning

GE modules designated A2, A3, and A4 contain signal conditioning for four electrical comparison sensors: FVG/CVG position, T2.5 temperature, and AB flame

detector, as well as for the two RTD temperature sensors that monitor internal EOU temperature. The design consists of 5 printed circuit boards. Each measurement is sent to the Litton electrical receiver board in the form of a 0 to 1.25 VDC analog signal, scaled as follows:

Measurement	Input Signal	Source	Range/Units
FVG Position	+6.075 to -6.75 VDC	engine ECU	0 to 2.7 inches stroke
CVG Position	0.153 to 1.376 VDC	CVG potentiometer	-3.5 to 52.5 degrees
T2.5 Temperature	-2.028 to 11.472 mVDC	T2.5 T/C probe	-65° to 540° F
AB Flame Detector	0 VDC / 5.0 VDC	engine ECU	light / no light
Internal EOU Temp.	392.5 to 740.1 ohms	RTD on CCD board	-55° to 125° C
Internal EOU Temp.	392.5 to 740.1 ohms	RTD in GE module	-55° to 125° C

5.3 CONAX T5 SIGNAL PROCESSOR

This is a dual board assembly measuring 0.7 X 2.0 X 4.0 inches (see Figure 19), incorporating a special optical connector to mate with the connector at the end of the 4-probed harness. The processor includes a thermoelectric cooler required to stabilize the germanium detector at temperatures about 50° C.

The output signal consists of a 12 bit binary code, representing T5 temperatures from 700 to 2500° F, which is sent to the Litton DAC board. Two status bits are also provided. One bit indicates the operational status of the signal processor and reflects Built-In-Test routines

evaluating RAM, ROM, and input/output operations throughout the normal program execution. The second bit indicates optical signal path condition which can be checked when the system is operating in ratio mode. The asynchronous parallel electrical interface allows the temperature value to be read whenever required.

Conax fabricated three signal processor assemblies for this program. At this stage in the technology development, to provide accuracy comparable with the F404 electrical T5 thermocouple harness, the signal processors are matched with a particular 4-probed harness assembly. One of the three processors was subjected to and passed the following environmental testing to demonstrate its ability to perform

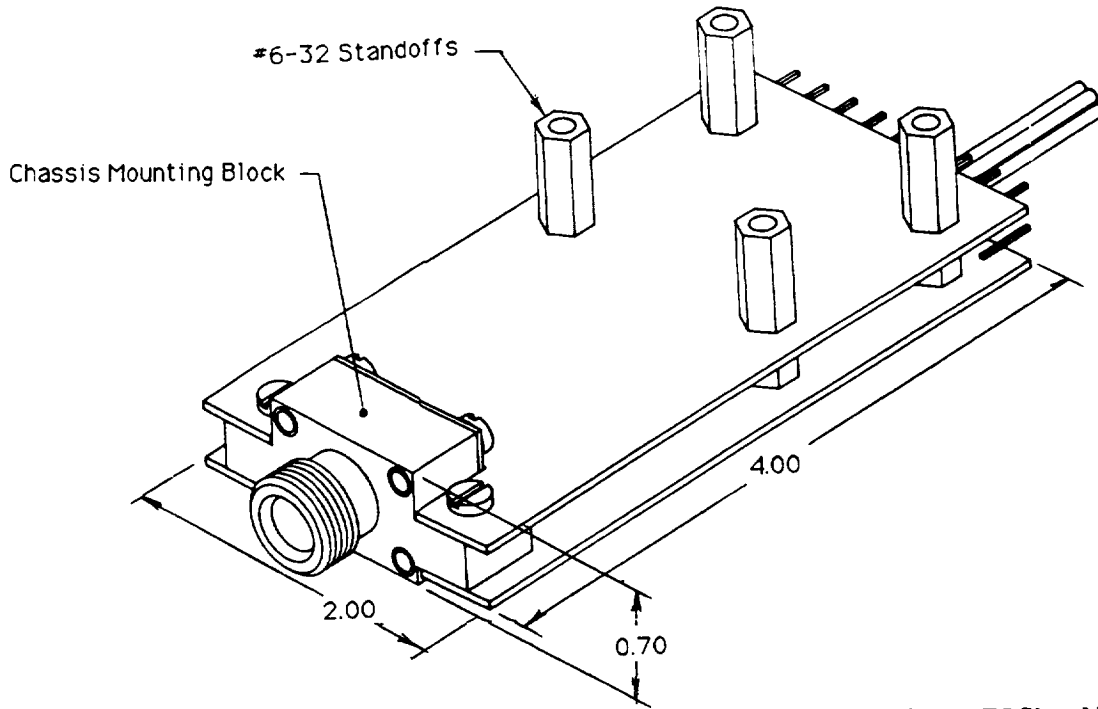

Figure 19 - Conax T5 Signal Processor

inside the engine-mounted EOU.

- 25 thermal cycles, -65° to 195° F.
- 24 hour thermal soak, 195° F.
- Vibration, 10 to 2000 Hz, 10 g's, resonance dwells/endurance sweeps.

5.4 AMETEK AB FLAME DETECTOR ASSEMBLY

This is a printed circuit board assembly measuring about 1.1 X 4.7 X 4.3 inches (see Figure 16), incorporating a special optical connector to mate with the connector at the end of the fiber bundle cable. The UV detector tube produces a train of pulses when the flame is detected. The

pulses are converted to 1 to 5 V square waves, 10 milliseconds wide, at 20 Hz, which is sent to the Litton DAC board.

Ametek fabricated three detector assemblies for this program. One of the three assemblies was subjected to and passed the following environmental testing, to demonstrate its ability perform inside the engine-mounted EOU.

- 25 thermal cycles, -65° to 230° F.
- 24 hour thermal soak, 230° F.
- Vibration, 10 to 2000 Hz, 10 g's, resonance dwells/endurance sweeps.
- Humidity, 5 days, 95%, 70° to 167° F

6.0 EOU DESIGN, ASSEMBLY, & TESTING

The EOU is designed to be an engine-mounted housing for the electro-optics and electronics circuitry used for signal conditioning the fiber optic sensors and some electrical comparison sensors tested in this program.

6.1 CHASSIS DESIGN

The EOU chassis is a riveted and dip-brazed aluminum structure with design features similar to the present production ECU chassis, and fabricated by a production chassis supplier. The most common material is 0.063 inch thick aluminum sheet per AMS 4026 or 4027, with chemical treatment (alodine) for corrosion protection. The structure uses U-shaped channels and solid block reinforcement to provide wall and corner rigidity.

The side and aft (not forward because of concern for contamination) panels contain cut-outs for the eleven interface connectors. The four chassis mounting brackets are brazed integral with the chassis framework. The assembly with covers is non-hermetic to allow for moisture drainage. Threaded holes for cover attachment screws and other installations use self-locking inserts or self-locking nuts.

The chassis' volume and external L shape (9 X 9 X 15 inch) were chosen to both house the needed circuit boards/modules and to facilitate its mounting on the F404-400 engine, with sufficient clearance for installation in the aft-looking-forward, left engine of the NASA F18 aircraft. A location on the installed engine could not be found to mount a simple rectangular-shaped chassis of sufficient size.

6.2 ASSEMBLY PROCESS

6.2.1 Assembly Stages

At GE Evendale, the two modules associated with the EOU power supply and the three modules associated with the signal conditioning of four electrical comparison sensors and the two internal EOU temperature sensors, were mounted into the chassis and tested as a subassembly. The Ametek detector assembly for the AB flame sensor and the Conax signal processor board for the T5 probe/cable assembly were also installed into the EOU and wired to the power supply. In addition, the nine MIL-C-38999 chassis interface connectors were mounted onto the side and aft

panels and a set of grounding lugs were installed and wired to the GE modules as applicable.

The partial assemblies were completed at Litton where the eight SEM-E board assemblies and the backplane were installed. A custom structural framework was used to hold the boards and backplane together as a subassembly unit. After installation they were wired to the power supply and interface connectors. Routed optical fibers are held in place using velcro.

6.2.2 Wiring

In each EOU, Litton fabricated and routed thirteen 100/140 micron fiber runs from their boards to a G&H termini (board-side) and from a mating G&H termini (backplane-side) to the appropriate MIL-C-38999 chassis interface connector. Those four paths returning to the optics receiver board contain optical attenuators for adjusting optical power. Because the T1 temperature sensor uses 200/240 micron fiber and G&H termini for that size were not available, this fiber was routed straight from the SEM-E board to the chassis connector.

A standard GE approach to module interconnection electrical wiring was used, including soldering to J-pins, trimming, and waterproofing. The majority of the wire is size per #24 AWG. Size #20 AWG was used for higher capacity power ground wires.

6.3 INTERNAL FEATURES

The five GE modules and the Ametek detector assembly are mounted in one leg of the L shaped chassis. The end surfaces of the GE module cans are mounted with threaded fasteners flush with the inner surface of the chassis fuel-cooling plate. The Ametek assembly slides between two rails and is clamped in place with its connector flange fastened to the chassis outer panel.

The other chassis leg contains the Litton SEM-E board/backplane subassembly and the Conax signal processor board. The Litton subassembly framework mounts with threaded fasteners into the chassis structure. The individual boards slide in through slots and are removable, except for the TRD board, which has a fiber pigtail directly to the MIL-C-38999 chassis connector contact that must be released. The Conax board fastens to

the chassis wall through standoff posts and its connector flange is supported by a chassis outer panel. Figure 20 is an internal schematic of the EOU assembly. Figures 21 and 22 show some of the internal/external features. Also refer to Appendix B, Figures 58 and 59.

6.4 INPUT/OUTPUT INTERFACES

These are described in Table 1. The nine chassis-mounted MIL-C-38999 interface connectors are electroless nickel-plated aluminum, square-flange, wall-mount receptacles with size 20 contacts for the electrical conductors, size 16 contacts for the fiber optic conductors. The fiber optic contacts are Amphenol pins per MIL-T-29504-4.

6.5 THERMAL STUDIES

The F404-400 ECU is designed to function under the following environmental thermal conditions. The EOU is mounted slightly aft of the ECU, so that the mounting surface temperatures are expected to be slightly higher. An additional factor is the internal electrical power heat dissipation, which for the EOU is a maximum of about 50 watts.

	Normal	Extreme
Ambient Temperature:	-34° C to 121° C	to 149° C for 7 minutes
Mounting Surface Temperature:	-34° C to 204° C	to 260° C for 7 minutes
Cooling Fuel Temperature:	-54° C to 95° C	to 107° C for 2 minutes

The extreme ambient and mounting surface temperatures are not expected to be a problem because of the EOU's large thermal time constant. However, if fuel is used to cool the EOU, the fuel, at its extreme temperature, could actually increase the EOU temperature very quickly.

High temperature capabilities of EOU circuitry include: power supply circuitry, 125° C; flame detector circuitry, 110° C; and T5 sensor signal processor, 90° C. As the temperature of the Litton SEM-E board set is increased from 75° C to 90° C the WDM CCD array detector dark current also increases. In this temperature range, because of decreasing signal-to-noise ratio, the signals of the four sensors (FVG, CVG, and VEN position sensors and the T2.5 temperature sensor) using this detection technique increasingly fluctuate until the signal cannot be decoded. As the capabilities of the EOU circuitry is exceeded, more and more data will not be valid, but the circuitry will recover when the temperature decreases.

Measures taken to monitor and control the potential EOU temperature problems in this program include:

1. The internal EOU temperature is measured in two places and the signals are transmitted on the 1553 data bus for monitoring.
2. The EOU power is designed to shut off when the internal temperature reaches 107° C, to provide some over-temperature protection.
3. NASA Dryden supplied some heat shield material to reduce radiated energy from the engine surface, during flight testing.
4. The EOU chassis is designed with the capability of using fuel flow (in series with the ECU) to cool the internal circuitry. Approximately 61 inches of aluminum tubing (0.25 inch OD, 0.18 inch ID) is brazed to the engine-side of the chassis walls.

6.6 TESTING (ref.9)

Three EOU's were assembled for this program. EOU #1 is designated the unit for full environmental testing. EOU #2 is designated the prime unit for engine testing. EOU #3 is designated the backup unit for engine testing. The following testing was performed at Litton Poly-

Scientific. Note that for bench testing, the NH speed sensor and T5 temperature sensor inputs to the EOU must be simulated because these sensors require engine operation in order to function.

6.6.1 Acceptance Testing of EOU #2 & #3

- Interfacing Checkout - Single point verification of correct MIL-C-1553 output with sensors/cables connected.
- Performance At Room Temperature - With sensors disconnected, optical output power measurement from each source port. With sensors connected, the optical output measurement from each electro-optic circuit using 10 data points from each sensor.
- Max/Min Temperature Testing - Repeat of room temperature performance testing at -55° C and 75° C.

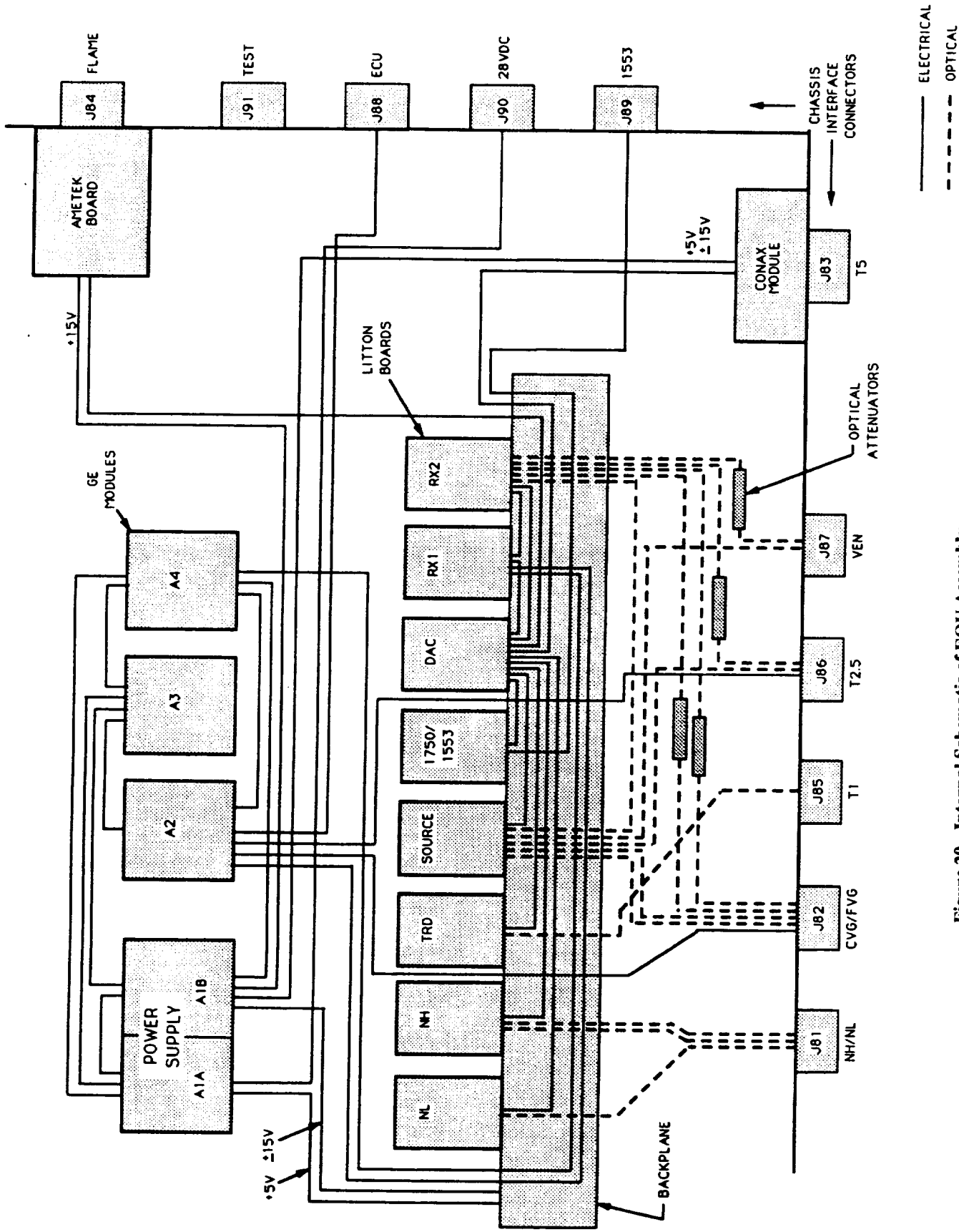

Figure 20 - Internal Schematic of EOU Assembly

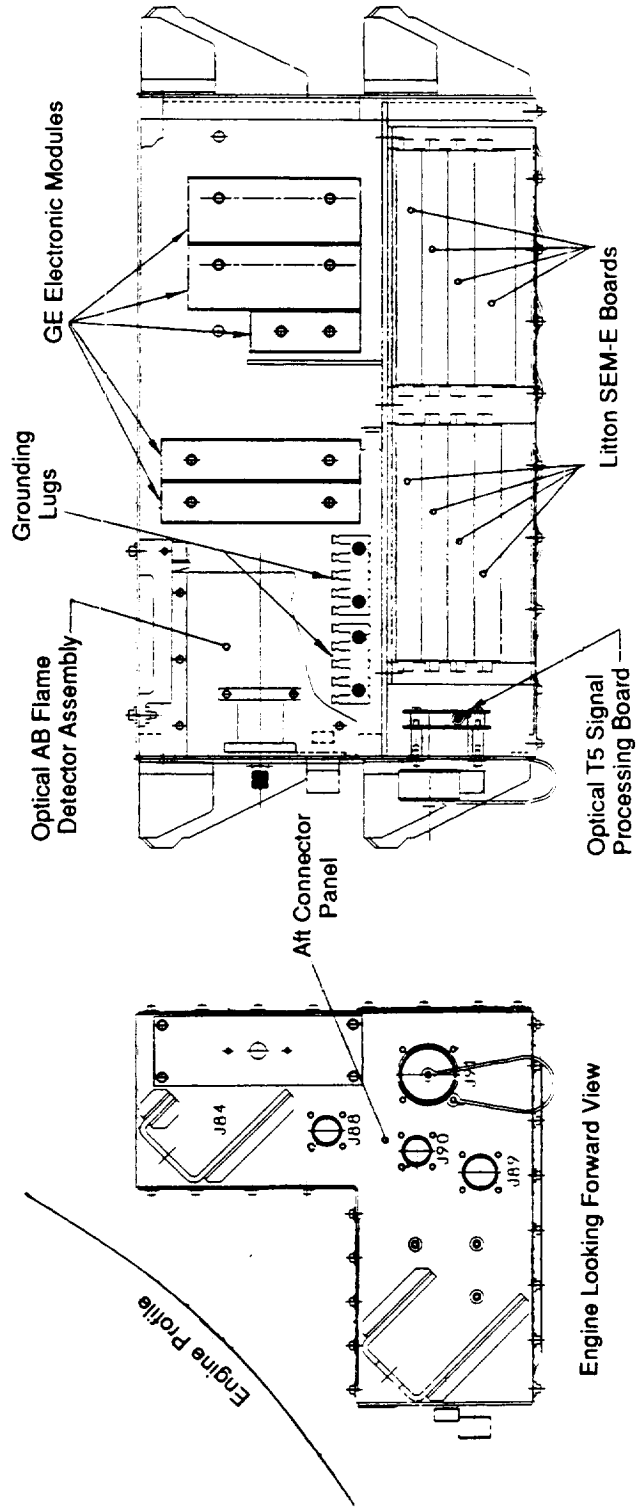
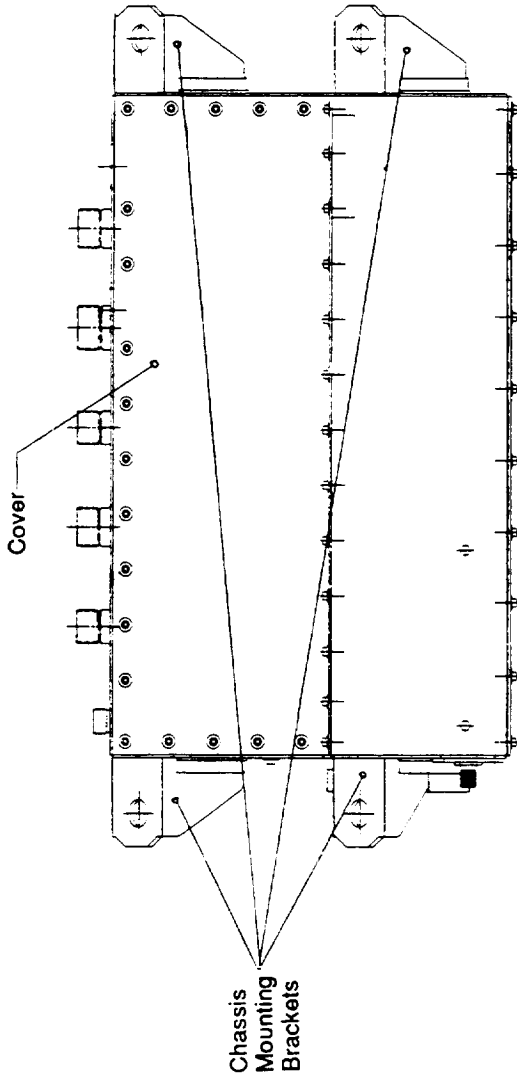

Figure 21 - Internal/External Features of EOU Assembly

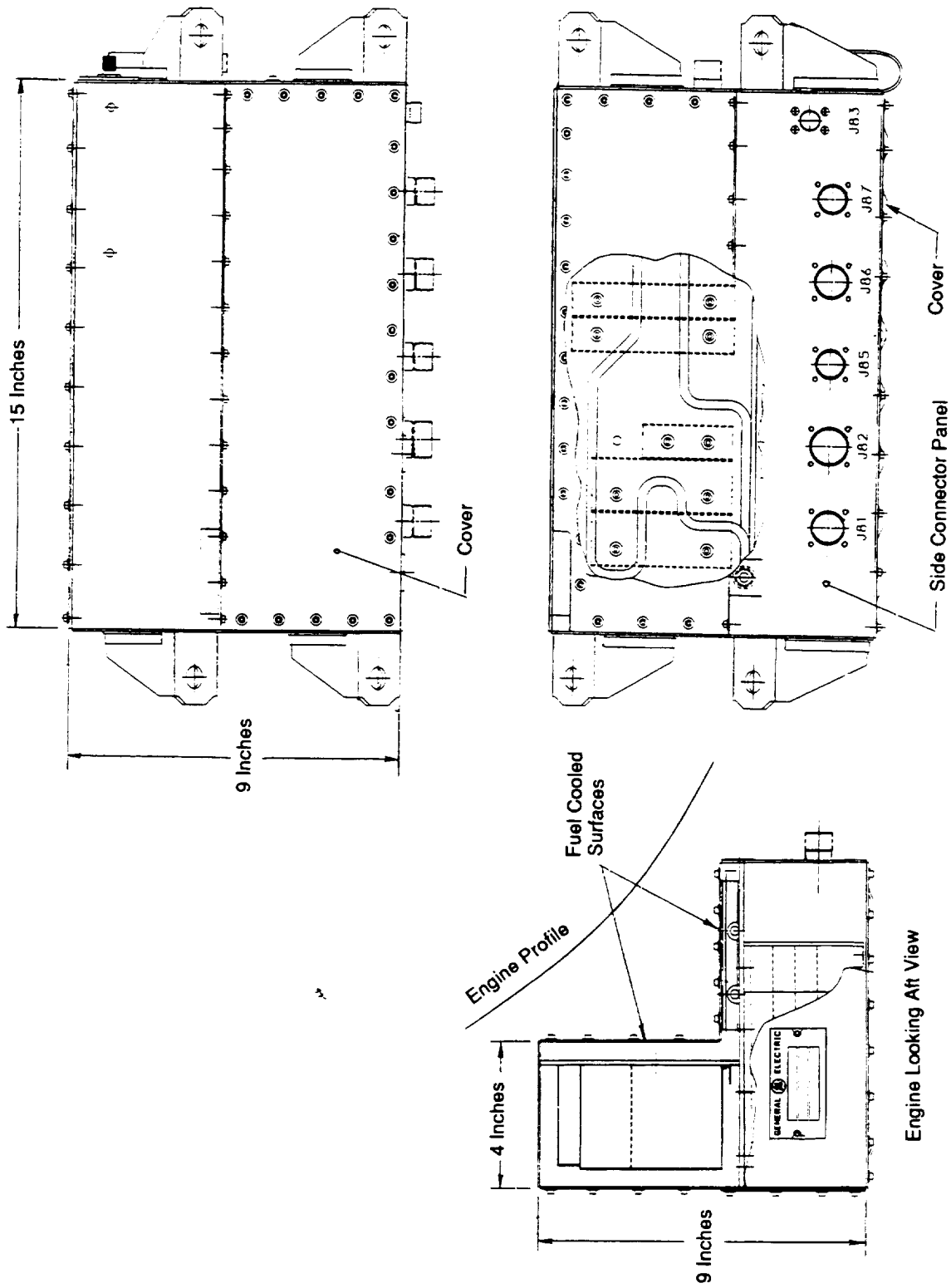

Figure 22 - Internal/External Features of EOU Assembly

Interface Connector Name	Connector Function	Connector Identification (D38999/20F)	Shell Size	Number of Conductors	Destination of Conductors Inside EOU	Destination of Engine Cable
J81	Optical NL/NH Sensors	C4PA	13	3 Fibers	To Litton NL/NH Boards	NL/NH Sensors
J82	Optical FVG/CVG Sensors	D97PB	15	4 Fibers 3 Wires	2 Fibers To Litton Source Board 2 Fibers To Litton Receiver Board 3 Wires To GE A2 Module	FVG/CVG Sensors
J83	Optical T5 Probes	Conax Special	--	4 Fibers	To Conax Signal Processor	T5 Probes
J84	Optical Flame Detector	Ametek Special	--	Bundle	To Ametek Detector Board	AB Case Spacer
J85	Optical T1 Sensor	B2PN	11	1 Fiber	To Litton TRD Board	Engine Interface Bracket
J86	Optical T2.5 Sensor	C4PN	13	2 Fibers 2 Wires	1 Fiber To Litton Source Board 1 Fiber To Litton Receiver Board 2 Wires To GE A2 Module	T2.5 Probe
J87	Optical VEN Sensor	B2PA	11	2 Fibers	1 Fiber To Litton Source Board 1 Fiber To Litton Receiver Board	VEN Sensor
J88	Electrical FVG/Flame Measurement	A98PN	9	3 Wires	To GE A2 Module	ECU Test Connector
J89	1553 Data Signal	B98PB	11	6 Wires	To Litton 1553 Board	Engine Interface Bracket
J90	EOU Power	A98PA	9	2 Wires	To GE A1A Module	Engine Interface Bracket
J91	Internal Test	F35PN	19	28 Wires	To GE Modules, Conax Processor, and Litton Boards	Engine Interface Bracket

TABLE 1 - EOU CHASSIS CONNECTORS

6.6.2 Environmental/System Testing of EOU #1

- 25 thermal cycles, -55° C to 75° C
 - 24 hour soak at 70° C
 - Vibration, 10 to 500 Hz, 3 planes, resonance dwells/endurance sweeps per F404 levels
 - Physical shock, 3 planes, 20 g's, 11 milliseconds
 - Electromagnetic Compatibility (EMC) - conducted/radiated emissions
 - Verification of performance with EOU and sensors in separate temperature chambers
- Thermal Testing

Thermal testing revealed information about the accuracy of the position sensor measurements. FVG position sensor measurements were virtually unaffected by the temperature of either the EOU or the sensor. However, the CVG/VEN sensors measurements were significantly affected. Factors in this included: a variation in the light bandwidth profile, especially at the cold end of the temperature range (even though a reference source signal is divided out); increasing detector dark current at the hot end of the temperature range; and variations in sensor insertion loss and dynamic range. The latter two factors make it difficult to budget the sensor system's optical modulations within the detector's operational range.

• Vibration and Physical Shock Testing

For the vibration and physical shock testing, a relatively complex fixture was fabricated allowing the EOU to mount on the vibration table in a manner which simulates its mounting on the engine. The testing was conducted at the Aerospace Testing Corporation, Roanoke, VA. During the testing the output was monitored and the cooling tubes

were pressurized with water. In the engine axial and circumferential planes, the only resonances were 46 Hz and 41 Hz respectively, which are below the one/rev engine excitation range (66 to 280 Hz). In the engine radial plane, resonances at 72 Hz and 118 Hz were found. At each of these, the EOU was subjected to about 4 hours of dwell vibration at representative engine input levels. In addition, a two hour sweep from 10 to 300 to 10 Hz was performed.

The vibration test identified no apparent mechanical problems. The internal attenuator settings were unchanged. The mounting brackets were visually monitored to be without significant response. However, during the dwell testing at 72 Hz, the EOU output display indicated a fault flag. No obvious external cause, like a loose connector, was determined. During the subsequent sweep testing, the output returned to normal. After internal examination, the cause is still unknown.

• EMC Testing

Radiated/conducted emissions testing per MIL-STD-461/462 was conducted at Cincinnati Electronics, Cincinnati, Ohio. Conducted emissions, test CE102, determines how well the aircraft equipment is protected from conducted noise exiting the EOU power circuits. The results were slightly over limits but considered passed. Radiated emissions, test RE102, determines if the aircraft equipment is sufficiently protected from radiated noise from the EOU system. The system did not pass this test. Litton suspects the heavy emission is being generated by sharp-edged clock driver circuitry in the processor. The aircraft was to be checked out before flight by powering up the existing equipment and then the FOCSI equipment. Additional shielding and grounding of the EOU cables, especially power, could be applied.

7.0 CABLE DESIGN & FABRICATION

7.1 IDENTIFICATION OF CABLE SET

The cable set for this program consists of fiber optic, electrical, and combined fiber optic/electrical cables branching from the EOU to sensor locations on/off the engine, to the engine ECU, and to aircraft sources for electrical power and data recording. These are shown in system schematic, Figure 2, and listed below.

1. EOU-J81 to optical NL/NH sensors.
2. EOU-J82 to optical FVG sensor and optical/electrical CVG sensors.
3. EOU-J83 to four optical T5 sensor probes.
4. EOU-J84 to optical flame detector spacer.
5. EOU-J85 to engine interface bracket to optical T1 sensor mounted off engine
6. EOU-J86 to optical/electrical T2.5 sensor probe.
7. EOU-J87 to optical VEN sensor.
8. EOU-J88 to ECU-J61 connector.
9. EOU-J89 to engine interface bracket to off-engine MIL-C-1553 data recording.
10. EOU-J90 to engine interface bracket to off-engine 28VDC power source.
11. NL sensor electrical jumper.

7.2 OPTICAL SENSOR LOOP FIBER CONFIGURATIONS

Figures 23 through 26 describes the optical fiber configurations and connector interfaces for seven of the nine sensors. The other two sensors, AB flame and T5 temperature, use simple point to point, probe element to detector, configurations. Note that for the six configurations shown, two sensors use four fiber-to-fiber connector interfaces, and four sensors use six fiber-to fiber connector interfaces.

7.3 GE-DESIGNED FIBER OPTIC CABLES

7.3.1 Fiber Optic Cable

These consist of cable numbers 1, 2, 5, and 6 as listed above, and described in Figures 23 through 26. The fiber cable is from Brand-Rex, and four fiber types, as designated by the sensor suppliers, were used. The NL/NH speed sensors use 100/140 micron, graded index fiber with 0.29 NA. The FVG/CVG position sensors use 100/140 micron step index fiber with 0.22 NA. The T1 sensor uses 200/220 micron step index fiber with 0.22 NA. The T2.5 sensor uses 100/140 step index fiber with 0.29 NA. All fibers are polyimide-coated and semi-loose within a thin-wall

fluoropolymer tube. The tube is surrounded by a braided, teflon-coated, fiberglass or kevlar strength member, covered by the teflon FEP outer jacket. The cable is rated from -65 to 200° C.

7.3.2 Fiber Terminations

The ends of the fiber cable are terminated with MIL-T-29504/4 or 5 (pin/socket) contacts, rated from -55 to 200° C. The procedure includes burning off a section of the polyimide, epoxying into the contact, and cleaving/polishing the fiber/contact end face. The epoxy used has a maximum rated service temperature of 200° C, but its full max to min range is affected by the curing procedure. The contacts are designed to install into the size 16 electrical contact cavity of a MIL-C-38999 Series III electrical connector, using standard insertion tools.

7.3.3 Conduit Assemblies

The fiber cable is housed within flexible, crush resistant conduit, also providing bend radius control. The thermally-stabilized inner PTFE conduit is available with inside diameters ranging from 0.188 to 0.625 inches, chosen to fit the number of conductors. This is wrapped with a reinforcing wire for added crush/kink resistance. If electrical wires are also present, as with the CVG and T2.5 comparison sensors, a nickel wire braid is applied and crimped to the metallic end fittings to provide shielding. The assembly is covered with a high temperature non-metallic outer braid.

The cable/conduit assembly features end fittings threaded to mate with the metric threads at the rear of the MIL-C-38999 Series III connectors. For multiple branches,

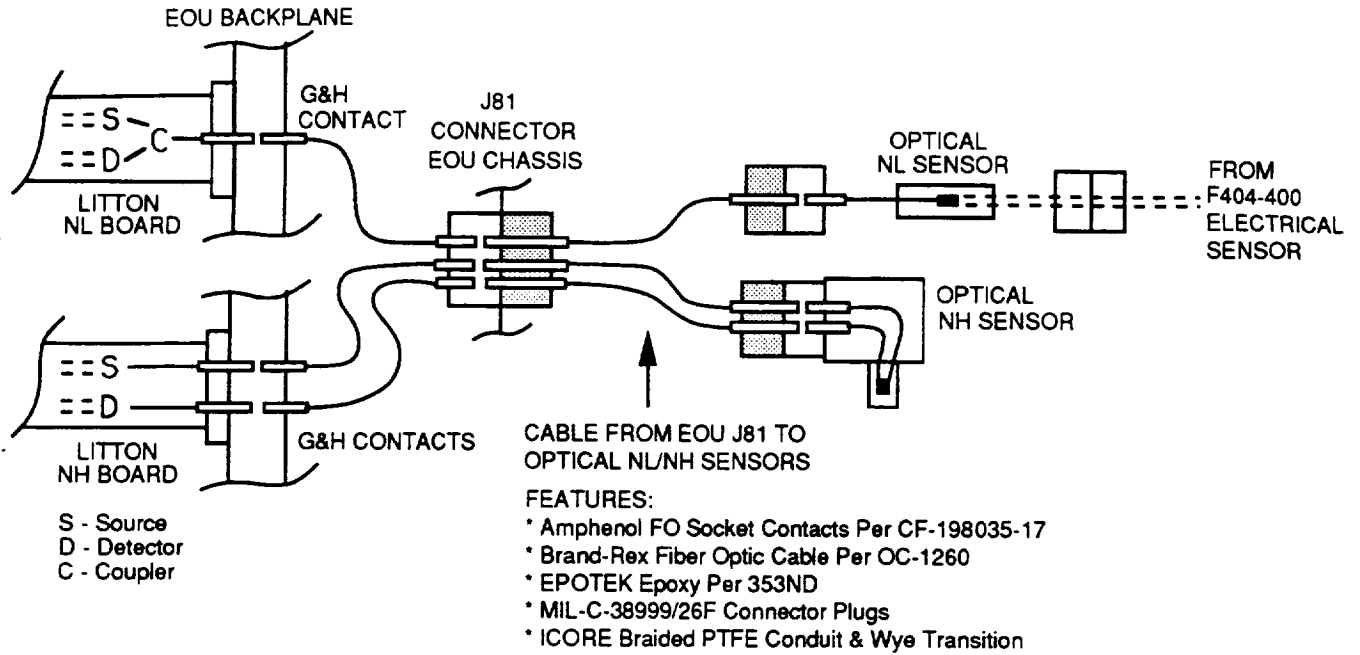

Figure 23 - Optical Fiber Configuration For NL/NH Sensors

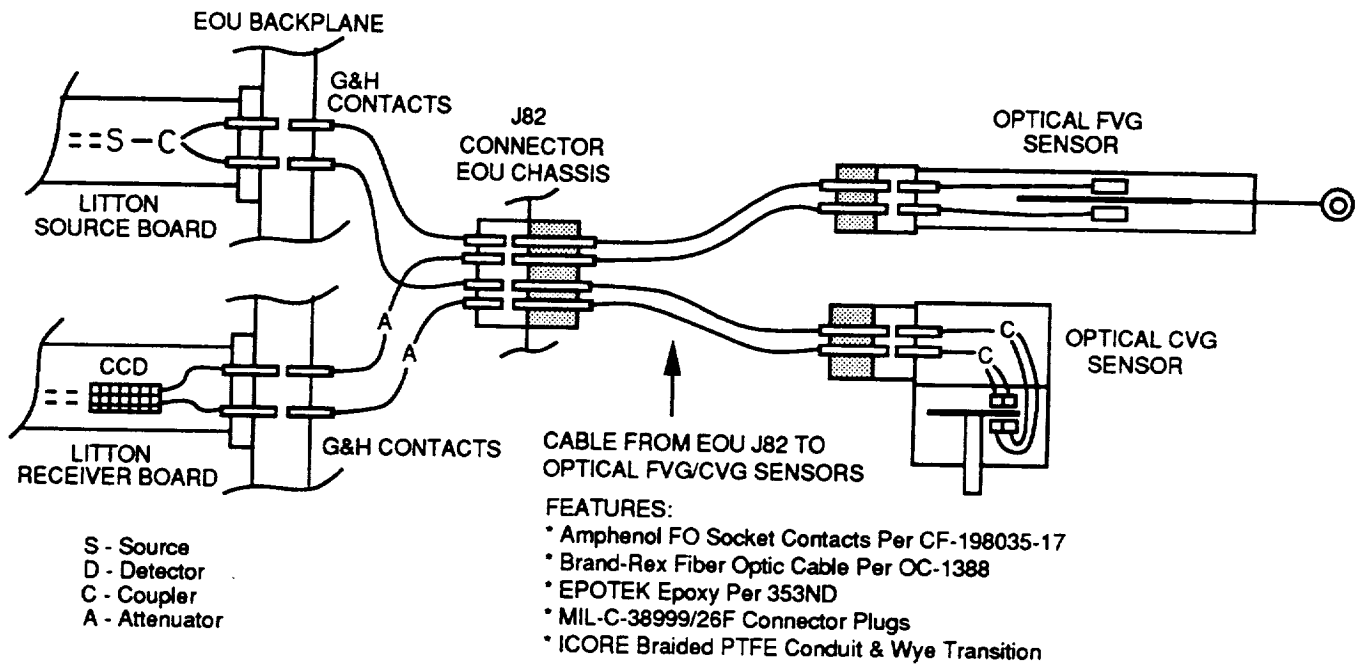
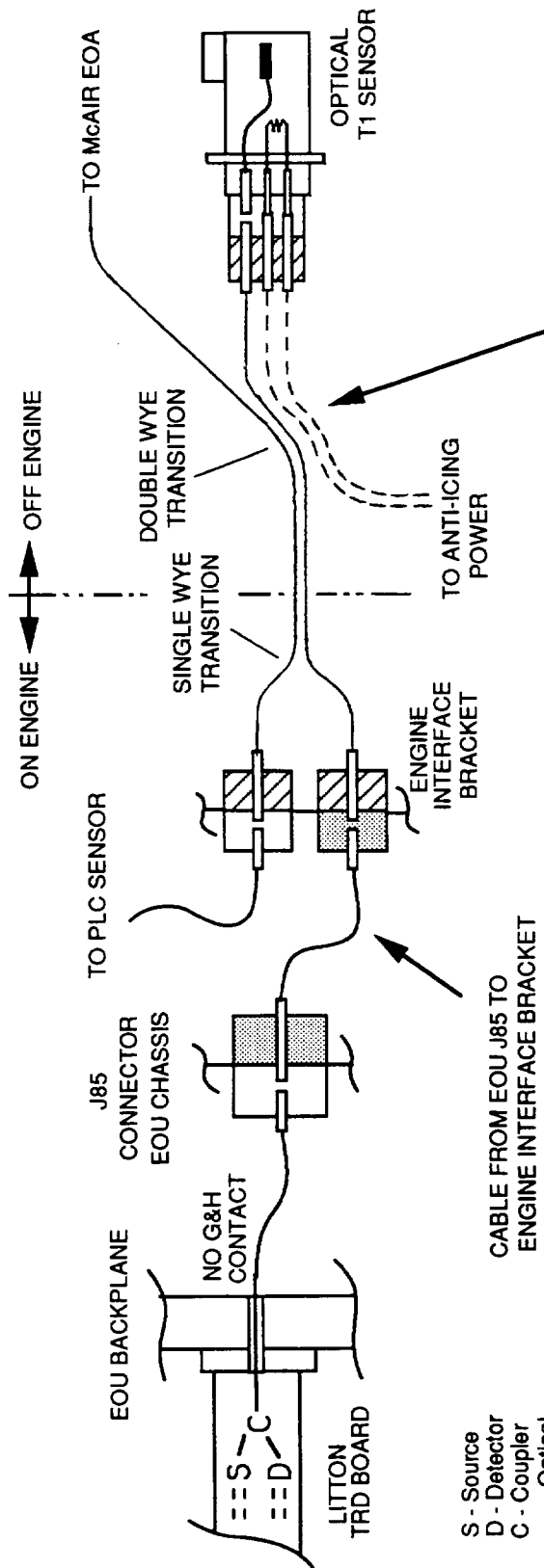

Figure 24 - Optical Fiber Configuration For FVG/CVG Sensors



S - Source
 D - Detector
 C - Coupler
 ——— Optical
 - - - Electrical

CABLE FROM EOU J85 TO ENGINE INTERFACE BRACKET

FEATURES:

- Amphenol FO Socket Contact Per CF-198035-57
- Amphenol FO Pin Contact Per CF-198036-57
- Brand-Rex Fiber Optic Cable Per OC-1283
- EPOTEK Epoxy Per 353ND
- MIL-C-38999/26F Connector Plugs & /24F Receptacle
- ICORE Braided PTFE Conduit

CABLE FROM ENGINE INTERFACE BRACKET TO OPTICAL T1 SENSOR

FEATURES:

- Amphenol FO Socket Contact Per CF-198035-57
- Amphenol FO Pin Contact Per CF-198036-57
- Brand-Rex Fiber Optic Cable Per OC-1283
- EPOTEK Epoxy Per 353ND
- MIL-C-38999/26F Connector Plugs
- ICORE Braided PTFE Conduit, Wye & Double Wye Transitions

Figure 25 - Optical Fiber Configuration For T1 Sensor

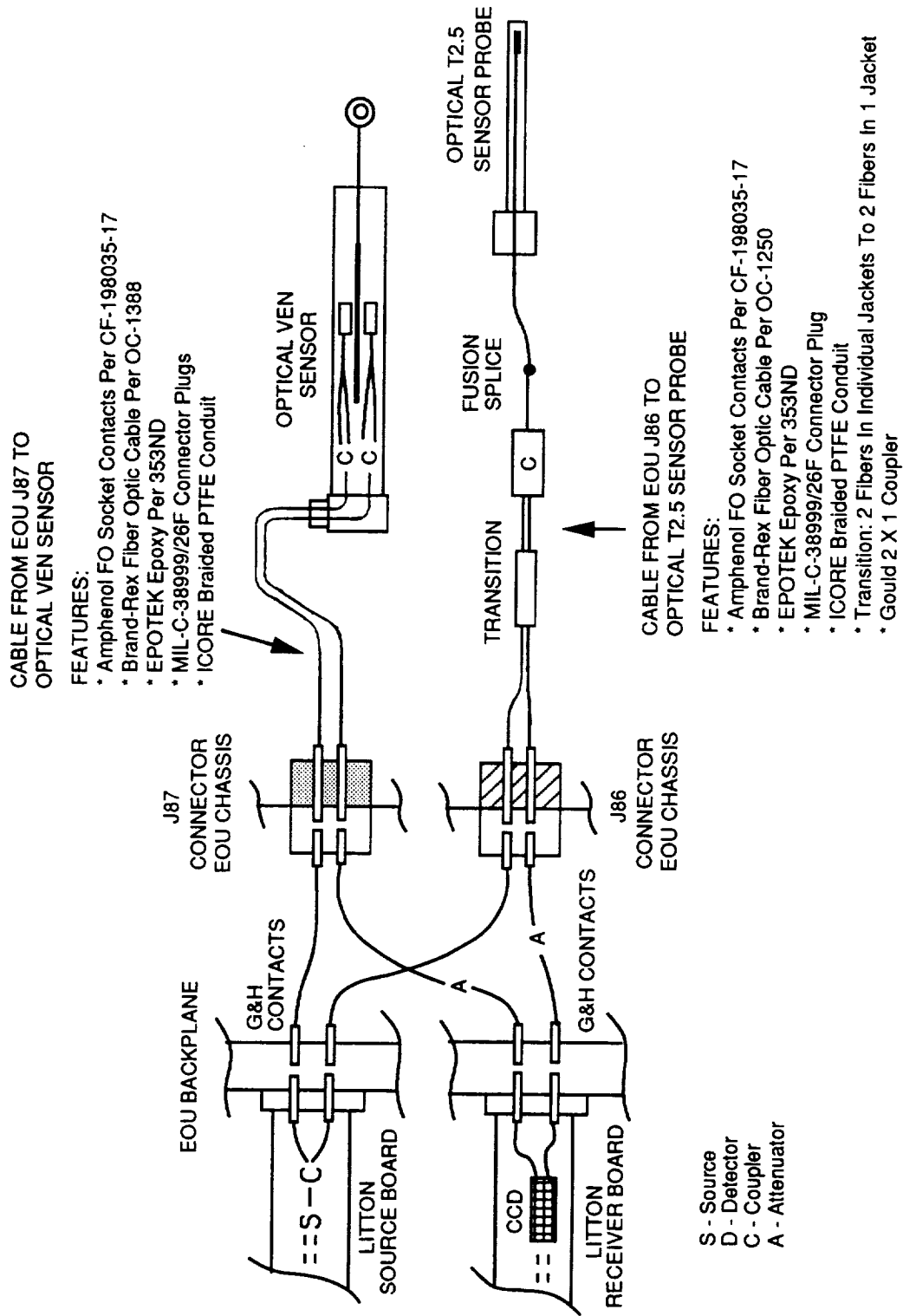

Figure 26 - Optical Fiber Configuration For T2.5 and VEN Sensors

sections of conduit are assembled using wye or double wye transition fittings.

7.4 SUPPLIER-DESIGNED FIBER OPTIC CABLES

7.4.1 VEN Position Sensor Pigtail

This is cable number 7 as listed in paragraph 7.1. The two fibers (100/140 micron, step index with 0.22 NA) for this sensor exist at 90 degrees with the sensor housing through a conical ferrule and into conduit similar to that used in the GE-designed cables. The pigtail is 90 inches long and fibers are terminated with MIL-T-29504/5 socket contacts and installed into a MIL-C-38999 Series III, shell size 11 connector plug for interfacing with EOU-J87

7.4.2 AB Flame Detector Cable

This is cable number 4 as listed in paragraph 7.1. This 59 inch long cable consists of a quantity of approximately 100, 200/220 micron, aluminum-coated, step index fibers with 0.22 NA. The overall cable spectral transmittance is established by spectroradiometric measurements in the wavelength range between 200 and 270nm. The fibers are hermetically metal sealed at the spacer (hot) end. The external sheath is a flexible stainless steel hose, 0.375 inches OD. Two fasteners are used to hold one end into one of the three spacer ports on the AB duct. The other end has a coupling nut for attachment to EOU-J84, actually a threaded boss on the detector board assembly.

7.4.3 T5 Temperature Probe Harness

This is cable number 3 as listed in paragraph 7.1. It is described in paragraph 4.3.1 T5 Temperature Sensor Design and shown in Figure 10.

7.5 ELECTRICAL CABLES

These consist of cable numbers 8, 9, 10 and 11 as listed in paragraph 7.1. They were assembled at GE Ft. Wayne, Indiana using the same design features and fabrication techniques as used for F404 production electrical cables, for example, double shielding, molded rubber-booted connector backshells, and outer spiral-wrap chafeguard.

- The EOU-J88 to ECU-J61 connector cable brings the electrical AB flame and FVG position comparison sensor signals from the ECU to the EOU using three 20 gage electrical conductors. The cable is 43 inches long.
- The EOU-J89, MIL-C-1553 data cable sends the EOU output data to the engine ground test or flight test recording system. Its other end mounts to the engine interface bracket for mating with an off-engine cable. It uses two channels of M17/176-00002 blue/white 24 gage wire, standard for MIL-C-1553 transmission. The cable is 66 inches long.
- The EOU-J90, 28 VDC power cable supplies EOU power from the ground test power supply or the aircraft for flight testing. Its other end mounts to the engine interface bracket for mating with an off-engine cable. It uses a single pair of 20 gage wires. It is 66 inches long.
- The NL sensor Y jumper cable provides electrical energy from the F404 electrical NL sensor to the fiber optic NL sensor, while maintaining an electrical NL signal to the ECU, as shown in Figure 6. The branch for the F404 NL signal uses two 20 gage pairs; the branch to the optical NL sensor uses one 20 gage pair. Overall the cable is 28 inches long.

8.0 INSTALLATION OF HARDWARE ON THE ENGINE

8.1 SENSOR INSTALLATIONS

8.1.1 T1 Temperature Sensor

This sensor mounts through a panel in the airframe's engine intake, about 5 inches in front of the engine. It is mounted using a method similar to that used for an icing sensor in an adjacent intake panel. The intake panel is stiffened with doubling material and the sensor flange mounting pad is supported by intake rib framework, not just the panel material itself. No mounting fasteners protrude into the engine airstream. See further discussion on this installation in Section 9.0 GE Flight Readiness Review, Chit #5.

8.1.2 T2.5 Temperature Sensor

This combined optical/electrical probe installs through the mounting flange of the sensing end of the F404 pneumatic compressor inlet temperature (CIT) transmitter, and is clamped in place using a Swagelok fitting, as shown in Figure 4. Two CIT transmitters, GE Part Number 5033T50P02 were modified for this program by drilling a 3/16 inch diameter hole through the flange into the probe cage, and by welding a Swagelok threaded boss onto the flange. The resulting modification is identified as GE Part No. 5033T50P02AA.

The existing F404 CIT transmitter was removed from the engine's compressor mid frame and main fuel control and replaced with the modified transmitter. The T2.5 probe was installed, the Swagelok nut was tightened, and its cable routed to the EOU, supported using cushion loop clamps.

8.1.3 T5 Temperature Sensor

This four-probed harness replaces the lower four-probed thermocouple harness on the engine AB case. Each probe flange uses two fasteners. The tips of the the optical probes are relatively fragile and must be inserted straight in. Existing cable clips are used to support some of the four branches, new cushion loop clamps for others. The four individual fibers to one fiber bundle transition section is well supported. The cable is routed to the EOU.

8.1.4 FVG Position Sensor

• Installation

This sensor contains a split collar designed to clamp around the sensor body and provide a flange for mounting onto the FVG actuator servovalve block with two fasteners. The sensor's rod end fastens to the actuator piston using two swivel linkages. These linkages are required to take up any misalignment between the parallel stroking of the sensor and the actuator. Figures 66 and 67 show the installation.

• Rigging

The sensor was rigged with the actuator against its fully retracted stop. In this position, the sensor and linkages were mounted but fasteners not tightened. The gross rigging adjustment was the position of the sensor body in its clamp. Fasteners were tightened after checking for binding over the full stroke. Fine adjustment was accomplished by rotating the sensor's rod end turnbuckle (± 0.050 inches capability) while reading the output signal from the EOU.

8.1.5 CVG Position Sensor

• Installation

The circular flange of this sensor mounts to a main supportive bracket using two U-shaped clamps. The main bracket in turn mounts with a slotted hole (for position adjustment) at a single point on a horn of the F404 main fuel pump assembly. A second smaller bracket adds support to the main bracket. The sensor shaft is coupled to the CVG actuation pivot stud using a flexible bellows and two split bushing clamps. Figure 68 shows the installation.

• Rigging

This sensor is very difficult to rig due to the crowded hardware in this area of the engine. With the CVG actuator fully retracted and the sensor and brackets mounted to the engine, the split bushing clamp set screws can be loosened to allow rotational adjustment, until the optical and electrical comparison signal monitored at the EOU are the

proper values.

8.1.6 VEN Position Sensor

- Installation

The engine AB case was modified by adding a hole through its aft cone to allow the VEN position sensor rod to extend through and fasten to a clevis bracket clamped around the AB ring. The additional hole is the same size as those through which the three VEN actuators and the electrical LVDT VEN position transmitter extend. The hole is located circumferentially at about 3:00 o'clock, aft looking forward.

The sensor body is supported in two locations. An additional set of brackets fasten to a circumferential rib on the VEN case and also support a set of blocks which clamp around the sensor body near its forward end. A cushion loop clamp fastened to a casing stud supports the sensor body near its aft end. This latter support is not a rigid clamp, but allows the sensor body to slip slightly under the axial thermal growth of the hotter casing. The cable pigtail is routed to the EOU. Figure 69 shows the installation.

- Rigging

With the VEN actuators in the fully retracted position, the sensor rod end was fastened to the AB ring bracket clevis, and the sensor body position adjusted axially until the EOU displays an approximately zero reading. The sensor body clamps were then tightened and the actuators extended to record sensor output at the fully extended end. Care must be taken to avoid exerting pressure on the sensor's relatively weak mechanical end stroke stops.

8.1.7 NL Speed Sensor

As shown in Figure 14, this sensor has a connectorized electrical cable pigtail and a connectorized optical cable pigtail. The electrical cable pigtail mates with one branch of the Y jumper cable (see Figure 6) receiving a signal from one of the two F404 NL speed sensors. The optical cable pigtail mates with the NL branch of the fiber optic cable interfacing with the EOU J81 connector, as shown in Figure 23. The sensor body is small and light enough to be supported with a loop clamp as part of the cable routing.

8.1.8 NH Speed Sensor

Installation of this sensor onto and through a modified alternator stator is described in the sensor design paragraph 4.8.1. Figure 27 is a layout of the F404-400 alternator stator showing the NH sensor installed. Figure 65 is a photograph of the modified stator.

8.1.9 AB Flame Detector

The F404-400 electrical flame detector and cable branch were removed in order to mount the fiber optic flame detector spacer onto the AB duct. The F404 flame detector was reinstalled onto the spacer using three fasteners into the spacer's self-locking inserts. This is described in Figure 7 and the photograph in Figure 70.

An analytical study was done to establish the increase in mounting bolt stress and the vibrational effect of adding the additional mass of the spacer, and moving the effective center of mass outward. The bolt stress showed a small (= 5%) increase compared with the initial prestress associated with assembly tightening. The shift in the assembly's first natural frequency was predicted to be about a 20% lower value, not thought to be significant. Actual data at Ametek showed the first resonance to be above 2000 Hz.

8.2 CABLE ROUTING/INSTALLATION

Figures 28, 29, and 30 show a rollout of the engine with the routing of the additional cables listed in paragraph 7.1. The lengths were sized using a F404-400 mockup engine at GE Lynn. The philosophy in routing was to follow established cable paths as much as possible. Standard cushion loop clamps of various sizes were used to fasten the cables to existing brackets and other cables.

8.3 EOU INSTALLATION

The EOU assembly contains vibration isolation at each of the four chassis mounting brackets per standard F404 design. This consists of inner and outer elastomeric isolators sandwiched between inner and outer metallic ferrules which impose a fixed squeeze and allow the chassis to float in the isolators.

The EOU chassis mounts to the engine using a ten piece bracket assembly, interfacing with the engine at eight casing studs. The installation straddles the interface between the outer bypass duct and the AB casing, with four interfaces on each casing. The brackets are designed to reach through existing components, positioning the EOU as close to the engine as possible without interference.

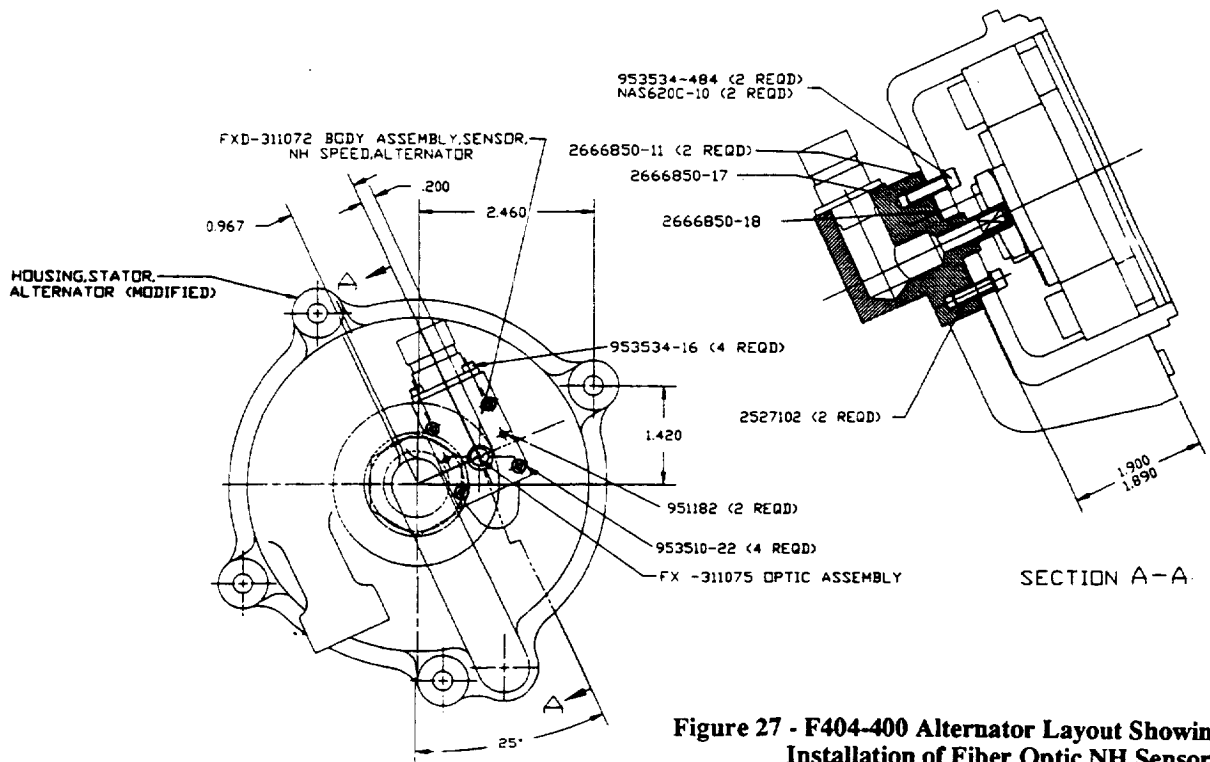

Figure 27 - F404-400 Alternator Layout Showing Installation of Fiber Optic NH Sensor

Installation sketches are shown in Figure 31. An aft-looking-forward photograph is shown in Figure 71.

The EOU chassis is designed to accept fuel cooling flow in series with and downstream from the ECU. The configurational modification is relatively simple. The flexible hose from the ECU return port to the rigid MFP return line was replaced with flexible hoses to and from the EOU, as shown in Figure 32. The additional flexible hoses were procured from the same supplier using the same design as other F404 flexible hoses.

8.4 F-18/ENGINE INTERFACE ISSUES

8.4.1 Physical Clearances

There was initial concern for two areas where potential interferences could occur between the hardware added to the engine and the surrounding structure in the aircraft. During flight maneuvers, the engine is restrained from moving by its mounts, but the aft end has some freedom to wag horizontally. The original installation design intent was to have a minimum of 0.75 inches clearance at any point around the engine

The fiber optic flame detector spacer, initially 0.75 inches high, left about 0.25 inches clearance between the electrical flame detector and an airframe structural rib. After flight testing measurements were taken, it was concluded that a 0.5 inch spacer would be acceptable. A new spacer was fabricated.

Early installation measurements around the EOU chassis initially showed about a 1 inch clearance. Using a completed EOU assembly and the finalized set of mounting brackets, accurate measurements were taken, showing less than 0.5 inches in one area. Flight test measurements confirmed this would not be a problem.

8.4.2 Cable Interfaces

The F404-400 engine includes a bracket mounted just forward of the ECU where the flanged connectors at the end of cables with signals being sent off engine are mounted. At this location, an additional bracket is mounted to the support the four additional cables interfacing with the airframe for FOCSI. These are for the 28VDC EOU aircraft supplied power, the MIL-C-1553 EOU output, the fiber optic T1 sensor signal, and McAir fiber optic PLC sensor signal.

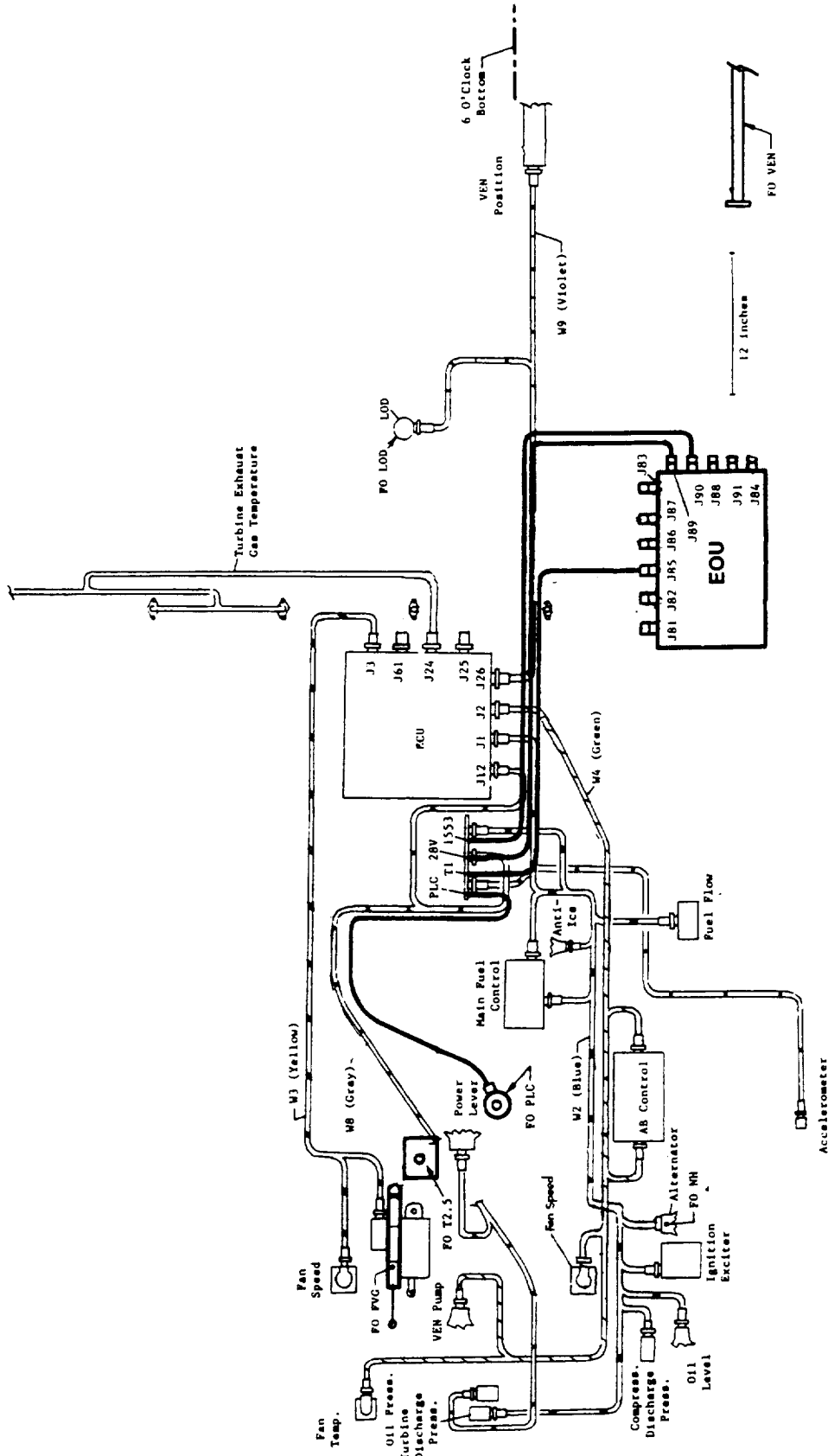

Figure 28 - Additional Engine To Airframe Cables:

- PLC Sensor Signal (McAir)
- T1 Sensor Signal (From EOU J85)
- EOU 1553 Data (From EOU J89)
- EOU 28 VDC Power (To EOU J90)

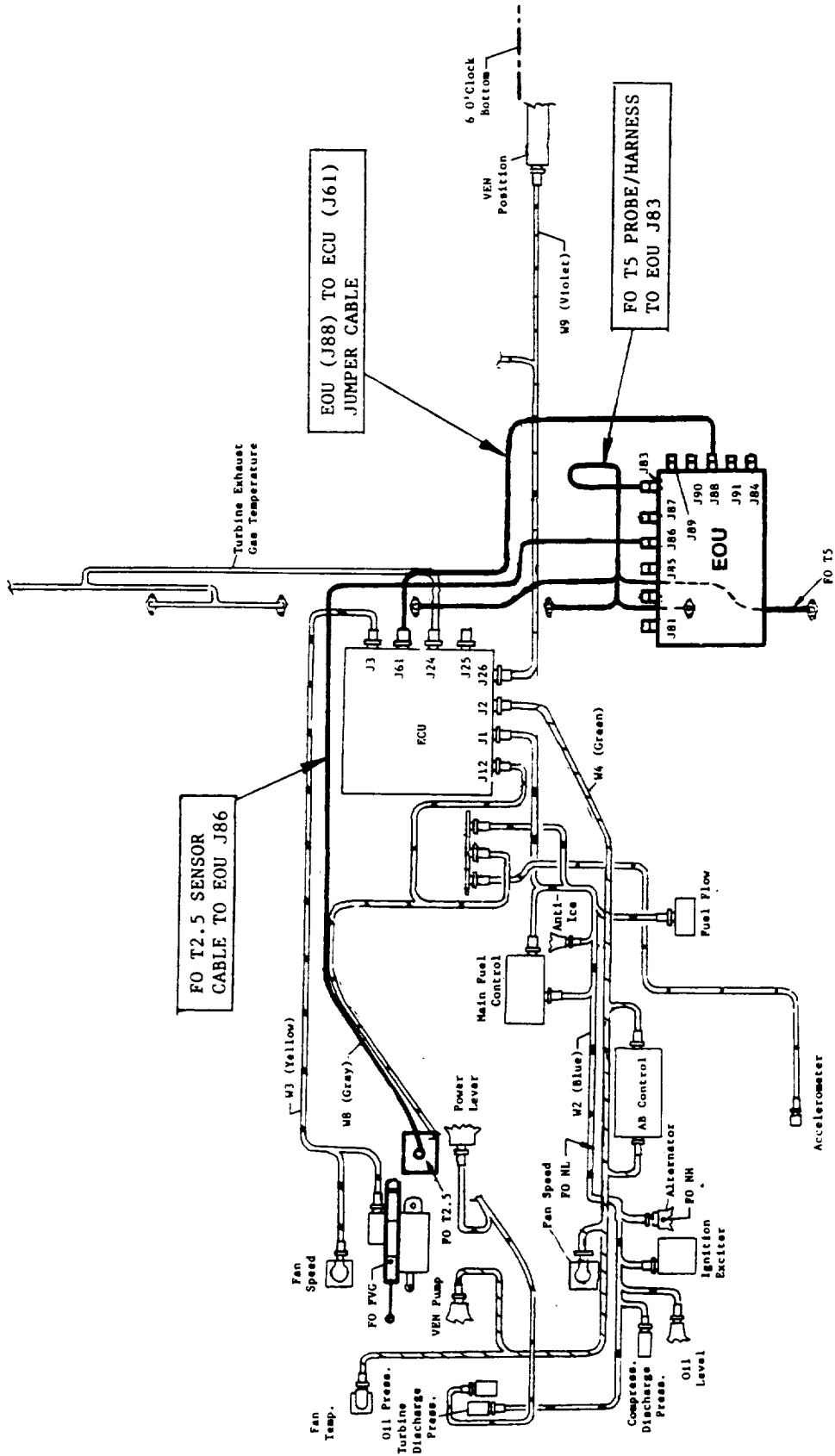

Figure 29 - Cables From EOU To T2.5 Sensor, T5 Probes, and ECU

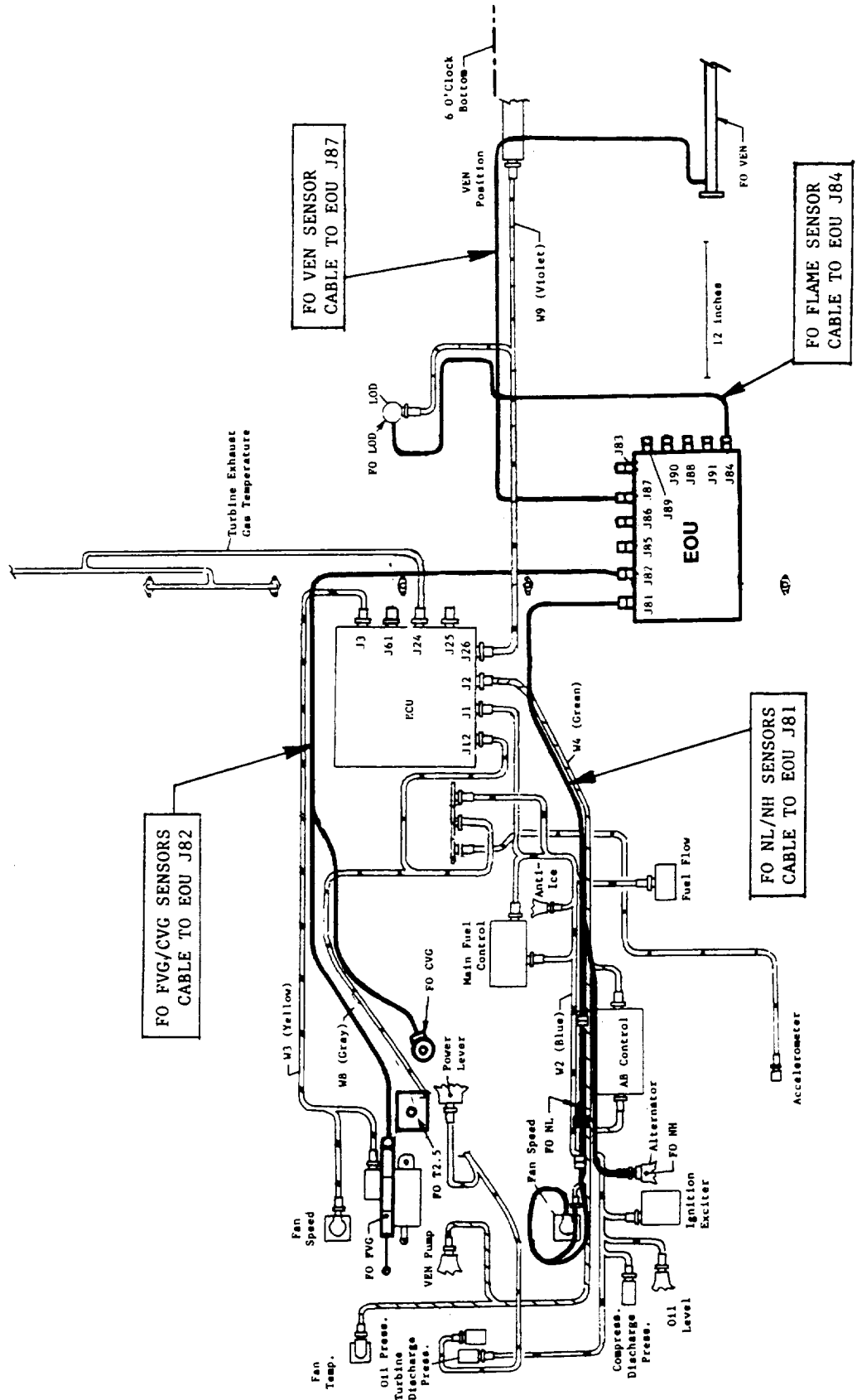
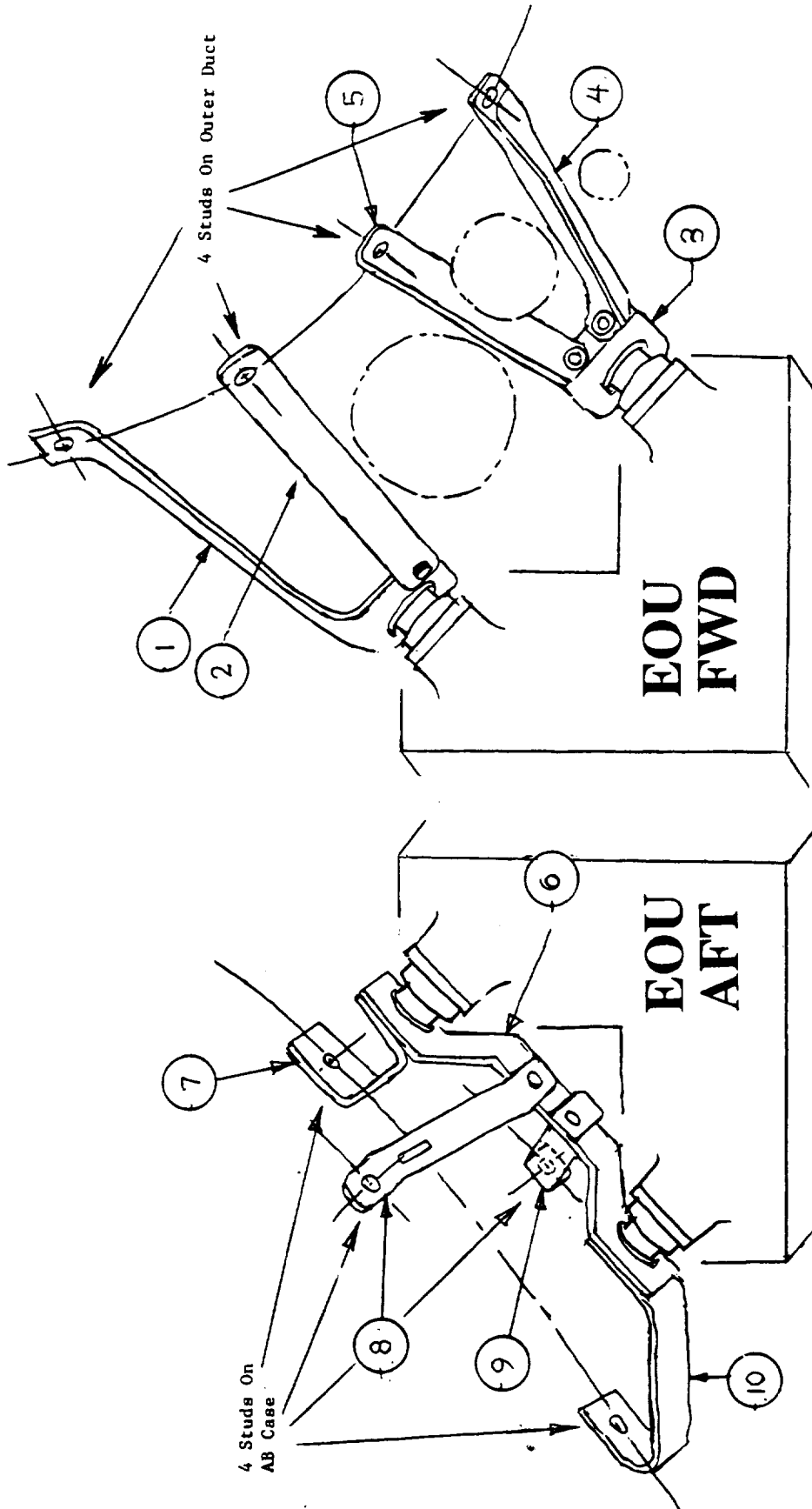

Figure 30 - Cables From EOU To NL/NH, FVG/CVG, VEN Sensors and Flame Detector



Forward-Looking Aft View On Bypass Duct

Aft-Looking-Forward View On AB Casing

Figure 31 - Views of EOU Mounting On Engine

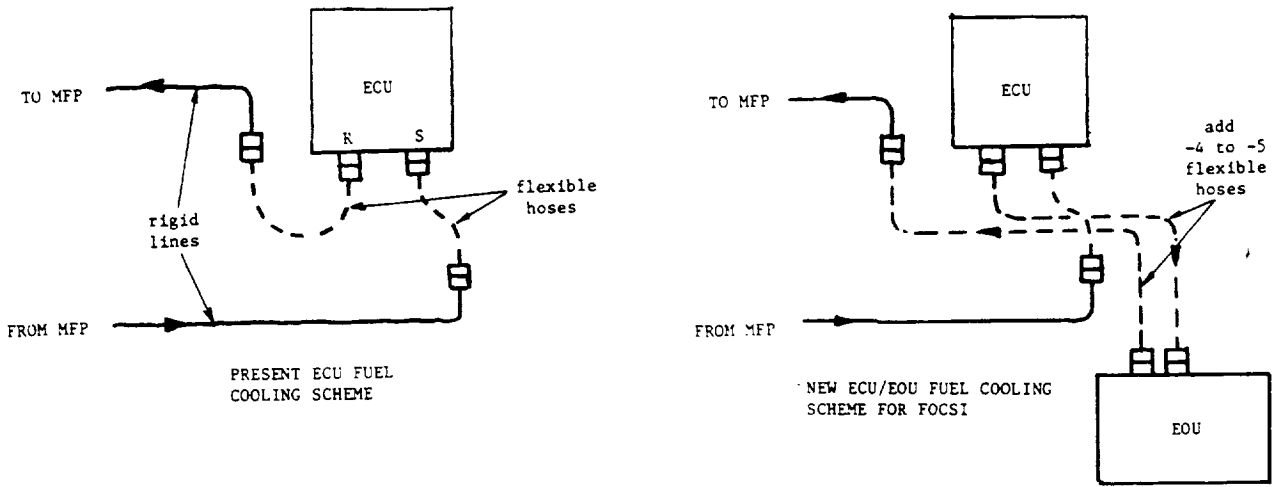

Figure 32 - Configuration of Fuel Cooling Hoses

9.0 GE FLIGHT READINESS REVIEW

9.1 REVIEW PURPOSE

This Flight Readiness Review (FRR) was held on June 6, 1993 at GE Aircraft Engines. The overall purpose of the review was to ensure the safety of operation of the installation. More specifically, the objectives were primarily, to identify any system, gas turbine, or installed equipment problems that require correction or special operating instructions prior to initial checkout, and secondly, to make recommendations for design, program, or procedures improvements that could contribute to the success of the program.

9.2 GENERATED CHITS & RESPONSES

Fourteen (14) chits were generated and prepared according to GE policies covering the FRR process. Three of the fourteen were judged to be Critical: #1, #5, and #6. Resolution and downgrading of the Critical chits was to be completed prior to the first flight. All chits were reviewed at the NASA FRR on 5/10/94.

1. ECU Fault Testing With EOU Assembly

The EOU is electrically connected to the engine ECU by the cable through which electrical FVG sensor and electrical flame detection comparison signals are transmitted to the EOU. The ECU system response to shorts within the ECU/EOU cable and to on/off powering of the EOU were performed at GE Ft. Wayne, IN on 4/26/94. The results showed that normal or failed operation of FOCSI hardware cannot affect normal operation of the engine control system.

2. Fiber Optic NL Sensor - Potential Failure Modes

The fiber optic fan speed sensor is electrically energized by tapping off of the output from one of the two existing fan speed sensors. Failure modes of the fiber optic sensor could corrupt and invalidate the electrical speed signal sent to the ECU. However, if the ECU senses any difference between the two fan speed sensor inputs, engine fuel flow is reduced to part power. No engine damage or personal injury will result.

3. Aeromechanical Integrity of the Fiber Optic T2.5 Sensor

The fiber optic T2.5 sensor probe mounts into the base of the existing F404 hydromechanical sensor, just behind the larger pneumatic sensing bulb. There was concern that it could be excited by vortices shed from the upstream sensing bulb. After analysis it was concluded that the probe's major resonance is safely above maximum one/rev engine speed and estimated vortex shedding frequency, and below the minimum blade passing frequency.

4. Frequency Response of New Engine Brackets

Fatigue failure of a bracket can occur due to its having a resonance in the engine operating range. Frequency response (ping) testing was needed to determine potential problems. Brackets can be modified to detune them and instrumented during engine testing. Ping testing was performed on 11/20/94 when all components were assembled on the engine, at 23 bracket and component locations. There were several responses in the engine operating range, all with considerable damping. Those of concern were instrumented during the second engine ground test on 4/18/94 and levels were low or very low.

5. Integrity of T1 Sensor Mounting

The fiber optic T1 sensor is mounted on the aircraft inlet duct, forward of the engine front flange. This is a new and untried location and sensor mounting configuration. The sensor housing itself is of a production inlet design. However, the frequency response and stresses in the inlet duct are unknown. NASA's mounting design includes substantial additional support and reinforcement. However, GE conducted a design review and suggested instrumenting the panel stresses/frequencies during aircraft ground/flight testing.

6. Potential Damage To MFP Due To Fiber Optic CVG Position Sensor

A bracket supporting the fiber optic CVG position sensor mounted with a single bolt at the end of the MFP inlet horn. Vibration testing by the sensor supplier showed that this configuration did not provide proper support. Damage to the MFP could cause a fuel leak.

The configuration was redesigned and solidified by installing an additional bracket. The redesigned sensor support system was reviewed and approved by GE Lynn

Configurations Engineering. Ping testing of the system revealed a highly damped resonance in the engine operating range. The second engine ground test included vibrate monitoring at this location.

7. Capping of Unused T5 Harness Connection At ECU

The ECU connector interfacing with the lower T5 thermocouple harness is no longer used (the lower harness is replaced by the fiber optic harness). A proper cap was installed to prevent any kind of false signal from occurring. In addition, it was confirmed that the ECU will average only the four remaining thermocouple inputs in computing T5 temperature; the open signals are not used.

8. Effect of T5 Harness Malfunction & Required Pilot Action

The remaining T5 thermocouple harness provides four signal inputs to the ECU. An open failure in a single probe is not noticed because only the good signals are averaged. A short failure in a single probe causes an erroneously low temperature signal, resulting in an increase in fuel flow. The pilot would probably feel an aircraft yaw and return to base. The possibility of simultaneous probe failures is remote.

9. Adequacy of Clearance Between AB Flame Detector & Aircraft Structure

The addition of a spacer for the fiber optic flame detector moved the standard detector radially outward 0.75 inches, leaving only 0.25 inches clearance. Because of engine movement during flight, interference is possible. Measurements during a flight test at NASA Dryden showed that a 0.5 inch spacer would be adequate and a new spacer was fabricated.

10. Clearance of Fiber Optic FVG Position Sensor With Airframe

This sensor is mounted directly to the F404 IGV servoactuator. Its location above and outboard of the actuator raised the question of adequate clearance with the airframe structure. Subsequently, measurements were taken on the engine at GE Edwards and an F18 installation at NASA Dryden, showing at least 1 inch clearance. If

interference occurs during engine installation, the sensor could be removed and mounted after the engine is installed.

11. Mounting of Fiber Optic VEN Position Sensor

The mounting system for this sensor was unacceptable at the time of the review. The mounting needed major improvement and the frequency response of the final system needed to be found and analyzed. Subsequently, the mounting system was redesigned. A sensor body clamp was provided using a bracket supported by a rib on the AB case. Ping testing revealed some somewhat damped resonances in the engine operating range. The sensor was vibrate instrumented during the second engine ground test. Results showed levels were relatively low.

12. Fuel Cooling System For EOU

The EOU is cooled by fuel discharged from the ECU. Concern is for the resulting fuel temperature increase and for if the resulting reduced flow is sufficient to cool the ECU under the worst flight test conditions. An analysis showed that the series addition of the EOU represents less than a 1° F increase in the ECU temperature, which should be totally acceptable.

13. Installation of the EOU

The EOU brackets mount at eight F404 stud locations. A concern is for the structural integrity of the bypass duct and AB case when the EOU is mounted on the engine. The EOU weight (25 pounds) and c.g. were measured. The appropriate GE Lynn designers were identified and provided with a detailed description of the EOU mounting. Both reviewers judged there should be no integrity problem and that a formal analysis was not required.

14. Fiber Optic NH Sensor Mounting Bolt Security

The bolts securing this sensor to the alternator stator pass through the stator body from the inside, and into self-locking inserts in the sensor housing. The bolt heads are inside the stator and not inspectable once the stator is assembled to the engine gearbox. If the bolts back out, interference with the alternator rotor would occur and the alternator would be damaged. The sensor must be inspected at reasonable flight intervals. NASA Dryden has scheduled to do this inspection.

10.0 ENGINE GROUND TESTING

10.1 FIRST ENGINE GROUND TEST

10.1.1 Purpose

The hardware designed, fabricated, and environmentally tested was ground tested at GE Flight Test Operation, Edwards, CA prior to installing the engine into the aircraft for flight testing. The first test was November 8-10, 1993. The purposes of the test included successful demonstration of the following:

- Installation and rigging of the hardware on the engine.
- Recording of fiber optic and comparison sensor signal data.
- Continued normal operation of the engine control system.
- Some verification of hardware flight worthiness.

10.1.2 Setup & Testing

The F404-400 engine supplied by NASA for both ground and flight testing was modified for installation of the FOCSI hardware as described in Section 8.0, Installation of Hardware. All FOCSI hardware was mounted on the engine in flight configuration except for the EOU and the fiber optic T1 sensor. The T1 sensor, designed to mount in the airframe engine intake, was strapped near the front of the engine support framework. Unfortunately, the supporting structure for the engine prevented mounting the EOU directly on the engine. Instead it was placed on a platform under the engine, just below where it would normally mount, and all cables were able to reach. See photographs of the engine in Figures 72 and 73.

This particular engine had been refurbished and required the standard F404-GE-400 break-in test prior to special test runs to gather data for FOCSI. During this time, the FOCSI data was visually monitored in the control room. Following the break-in test, additional transients and steady-state operations were performed in order to record as much of the sensor ranges as possible. Near the end of the testing, the EOU fuel cooling hoses were installed for several minutes.

10.1.3 Sensor Data

Prior to engine testing, a PC was used by Litton to look at the EOU output signals in a format displaying the raw spectral data. In this mode, the WDM sensor optical attenuators in the EOU were adjusted for required circuit light level. For data recording during the test, the EOU output signals on the MIL-C-1553 data bus were converted to analog format and recorded with the electrical sensor comparison signals (T1, T5, NL, NH, and VEN) coming from the engine ECU. Following are descriptions of the EOU output data.

• Fiber Optic T1 Temperature Measurement

Initially the signal was very noisy/fluctuating. The signal fluctuation amplitudes significantly reduced when the spare cable was installed, but they were also noted to increase at higher engine speeds (airflows/vibration levels). It is suspected that connector back-reflections and/or inadequate connector contact end face quality are a factor. Subsequently, a lab experiment showed that slowly unmating the connector causes the signal to increase in error and standard deviation.

The fiber optic T1 sensor measurement was within 5 degrees C of the engine electrical sensor measurement at the outdoor test cell ambient temperature levels. Based on Litton calibration data, variation of this magnitude is expected and may improve at other temperature levels. Being at the engine inlet, testing over the sensor's range was not possible during ground testing. A dip in the electrical sensor measurement with increasing airflow was most probably due to lack of dynamic recovery. The optical probe was not subjected to engine airflow.

• Fiber Optic T2.5 Temperature Measurement

Litton had difficulty processing this signal due to its relatively small modulation over range. A slope intersection software technique was chosen, resulting in very poor resolution and a very fluctuating signal. In addition a large offset was left in the signal calibration causing the measurement to saturate at its 540° F limit during an engine acceleration. Improvements in this signal are described in Paragraph 10.2, Second Engine Ground Test.

• Fiber Optic T5 Temperature Measurement

During engine testing, a minimum 700° F value is displayed due to the optical sensor's lower range

limitations. Above 700° F, the fiber optic measurement and the engine thermocouple signal tracked very closely with very small if any offset on a steady-state basis. During fast transients, some differences occurred, probably due to differences in probe thermal time response.

- **Fiber Optic FVG Position Measurement**

The optical sensor signal was relatively clean and stable and tracked with the engine FVG LVDT signal with very little offset, within approximately 0.1 inches.

- **Fiber Optic CVG Position Measurement**

The optical sensor signal was relatively clean and stable. The optical and electrical comparison signals (from the same component) were offset about 10 rotational degrees (a calibration bias), but tracked very well.

- **Fiber Optic VEN Position Measurement**

The optical sensor signal was a little noisy but the optical sensor tracked with the engine VEN LVDT signal reasonably well. There seemed to be a scaling error such that optical sensor range was foreshortened, for unknown reasons.

- **Fiber Optic NL Speed Measurement**

Due to a combination of apparent radiated and conducted interference, the Litton EO circuit was not expected to function with the sensor when physically integrated into the EOU. The sensor has a larger insertion loss and a much smaller modulation depth than Litton anticipated. Litton attempted a number of fixes and improvements without success. However, the sensor performed satisfactorily with separate EO circuitry.

For the first engine ground test, the sensor was installed on the engine and monitored separately. The signal initially accurately tracked the engine electrical NL speed sensor for part of the speed range, but then dropped off to zero. The problem is not thought to be sensor related, but a cause was not isolated. See Paragraph 10.2, Second Engine Ground Test.

Fiber Optic NH Speed Measurement

The optical sensor signal tracked very accurately with

the engine NH speed measurement, but was very noisy/fluctuating. Litton suspected the cause of the fluctuations to be poor resolution in the signal's digital processing, such that a small amount of speed jitter results in a large apparent speed signal jump.

Fiber Optic AB Flame Detector Measurement

The flame on/off signal from the fiber optic sensor occurred virtually coincident with the engine electrical signal. This demonstrated that the fiber optic cable successfully transmitted enough energy to trigger the detector, and that the electrical flame detector continued to function normally at the ambient temperatures tested.

10.2 SECOND ENGINE GROUND TEST

The second engine test was designed to prepare the final configuration for flight testing, including the following list. The test took place in two phases. The first phase took place April 5-8, 1994. Excessive engine vibration prevented reaching over 86% speed, but data was recorded. After replacing the engine fan module, the second phase took place April 19, 1994. A sampling of the EOU output signal data is shown in Figure 33.

- The original T2.5 sensor software algorithm was replaced with a wavelength response ratio technique to improve resolution, and the calibration offset was minimized. The improvements were demonstrated.
- The NL sensor was monitored both through the EOU (above ~ 65% speed) and over the full speed range through separate signal processing supplied by Banks Engineering.
- Sensors were mounted to measure vibration levels at the FVG/CVG/VEN position sensors, identified as locations of concern from the previous ping testing. Monitored levels were low.
- A forced hot air method, without engine operation, was used to confirm T1 sensor functionality over a large portion of its range.
- Mounting and functional check of the McAir fiber optic PLC rotary position sensor was performed.

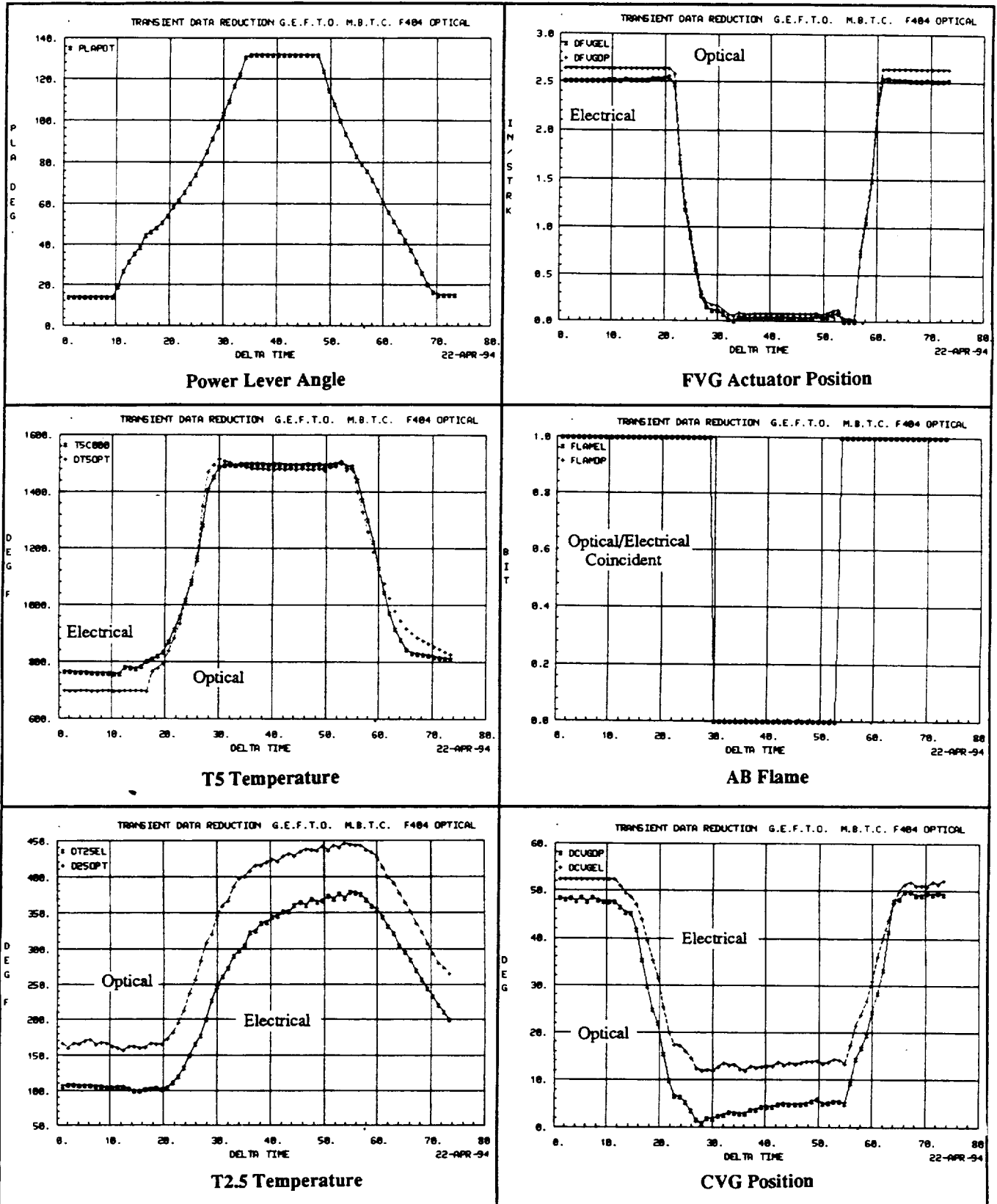

Figure 33 - Sensor Signal Data From Second Engine Ground Test

11.0 DISCUSSION OF RESULTS

In the process of designing, fabricating, and testing the fiber optic sensing system components in this program, lessons have been learned which are contributing to the development of fiber optic technology for aircraft engine application. This section reports many of those lessons learned and other observations.

11.1 SENSING TECHNIQUES

1. Position Sensor Performance

In this program, two types of position sensing techniques were demonstrated. Testing results showed that to achieve good accuracy and unit-to-unit interchangeability, the WDM analog ratiometric technique (CVG/VEN sensors) requires close attention to minimizing variations in the light source power and shape and in matching variations in the optical circuit power budget with the detector's operational range. The WDM digital technique (FVG sensor) is more tolerant to the above variations. **Lesson:** Of the methods demonstrated, the WDM digital position sensing technique probably has a higher potential of achieving the performance required for engine application.

2. T1 Sensor Measurement Fluctuations

With the time rate of decay sensor and electro-optic circuitry used in this program, the sensor signal had significant noise/fluctuations and poor accuracy. Back-reflections from one or more of the connector interfaces is a suspected contributor to the noise. Also, connector losses are known to contribute to inaccuracy when using the signal processing phase technique. This was evidenced by the difference in fluctuation level when different cables were used. An experiment showed that both temperature measurement accuracy and the standard deviations worsen as a connector is loosened. **Lesson:** Sensor measurement performance can be related to connector contact quality and cleanliness. And this is probably more the case when back-reflections affect the signal.

3. Position Sensor Sliding Surfaces

Considerable effort was spent in design/test of the linear position sensors (both FVG, digital wavelength division multiplexed, and VEN, analog wavelength ratiometric) with respect to contamination due to wear from the sliding surfaces. This contamination produces errors in

the sensing measurement. Abbreviated production endurance testing was performed for this program. This should be an area of focus in future design reviews.

11.2 DESIGN

1. Sensor Interchangeability

Being able to replace a sensor or cable or EO circuit on an engine with minimal effect on the performance of the sensing measurement is a requirement for production systems. Equalizing the insertion losses and dynamic ranges of a set of the same sensors merely through, for example, meeting tight manufacturing tolerances, is very challenging. A convenient method of trimming individual light paths may be required. Continue to push all aspects of the interchangeability issue. Design circuitry tolerance to sensor/cable variations.

2. Electrical Shielding In Fiber Optic Cables

Sections of the engine fiber optic cables for FOCSI also contained electrical conductors for comparison sensors and an anti-icing heater element in the T1 sensor. In these cases, it was required to add outer nickel braiding in the conduit for shielding, thus significantly increasing the weight and cost. Trade off weight/cost of combining or separating optical and electrical conductors for future programs.

3. Clearance For Engine Installation

Mounting of FOCSI hardware on the engine initially considered only the static position of the engine in the aircraft. In two cases, the optical flame detector spacer and the EOU assembly, clearance for the engine with these parts installed was doubtful, because of the movement of the engine during flight maneuvers. NASA measurements during flight showed that the spacer needed to be modified, but that clearance with the EOU was sufficient. Allow for at least 0.75 inches around the F404-400 engine when designing installation of additional hardware.

4. Signal Noise Caused By Poor Processing Resolution

Both the NH sensor and the T2.5 sensor MIL-C-1553 recorded signals had considerable imposed noise. The NH signal noise is suspected to be caused by poor resolution in

its digital signal processing. Thus a small amount of noise or jitter in the sensing process causes an apparent (not real) large speed signal jump. A new NH board design could fix the problem. The initial T2.5 sensor signal was very noisy because of very high gain software algorithm. Subsequently an improved algorithm was suggested by the sensor supplier and implemented. For the cause of noisy signals, consider signal processing deficiencies.

5. Conduit For Fiber Optic Cable Packaging

The conduit used for FOCSI provided good radius control, crush resistance, repairability, engine installability, and was relatively easy to assemble. However, because of the variety of branch sizes requested, with some branches requiring nickel braid shielding, the cost was relatively high. Consider cost reduction measures for future programs.

6. WDM Sensor Signal Processing

The chosen CCD array for the WDM sensors could have had many fewer rows and the rows could have been more optimally placed to accommodate optical spectra locations. The array size needed to be small enough to attach directly to the optical glass block. Optical aberrations are a suspected major cause of the WDM analog sensor calibration (accuracy) problems. **Lesson:** A custom CCD with reduced size and complexity would be preferred over the chosen commercial one. The WDM optical block assembly needs to be redesigned to reduce aberrations.

11.3 FABRICATION

1. Connector Contact Epoxy

One factor in the choosing the appropriate epoxy type and the appropriate epoxy curing procedure for use in terminating fiber optic connector contacts is the expected temperature environment. Cables made for lab testing purposes may be fabricated for the lower temperature requirements, but may later be mistakenly used to mate with a component in a high temperature test. The result could be fiber pistoning and damaging of an expensive component's connector contact. Be mindful of how cables are fabricated and how they may eventually be used.

2. Fiber Cable Stabilization

The fiber cable used for this program consists primarily of a semi-loose tube design. The fiber is enclosed by a small inner fluoropolymer tube which is wrapped with a strength member braiding and covered with an outer

jacket. After high temperature (350° F) soak testing of a T2.5 sensing probe and connectorized fiber optic pigtail, using one model of this fiber cable style, it was discovered that the inner tube irreversibly shrinks up to 2.5% in length and becomes somewhat sticky. This resulted in fiber stresses causing fiber microbend losses and changes in the transmitted mode distribution in the Fabry Perot sensing technique, and a considerable calibration shift. **Lesson:** A fix is to pre-bake and then straighten and gently shake the cable until the fiber is loose within the tube.

3. Connector Contact Termination

The procedure for terminating size 16 fiber optic contacts for MIL-C-38999 connectors includes sizing the fiber length, removing the polyimide cladding, applying epoxy, assembling fiber and contact, curing the epoxy, scoring and breaking the fiber, and polishing. The fiber is very easy to break by mistake once the polyimide cladding has been removed. The correct polishing procedure is critical in producing low loss performance. And frequent elimination of residue during the polishing procedure is a key to good results. **Lesson:** Frequent cleaning of residue during fiber polishing is an important key to successful contact terminations.

4. Use of Epoxy In Component Assembly

Epoxies are typically used in fiber optic assemblies for purposes of, for example, accurately aligning optical pieceparts. Locking fasteners are more commonly used for structural purposes in engine component packaging. **Lesson:** Assembly techniques may need to be redesigned or new techniques will need careful evaluation for long life performance over the typical -55 to 200°C engine environment.

11.4 COMPONENT TESTING

1. Technician Instruction About Fiber Optics

During setup for the first engine ground test, a spare fiber optic cable with only teflon jacketing protection was used to replace the initial cable, packaged in conduit. The test technician stowed the slack cable and unknowingly folded it into a very tight bend radius, kinking the jacket. This would have been appropriate for electrical wiring and surprisingly it initially still functioned. However, after repeated use, the weakened section resulted in a failure. **Lesson:** Technicians must be made fully aware of the limitations of fragile test cabling. Spare cables should be available at the test site. Cable failures can be prevented by using bend-radius limited and crush resistant packaging.

2. Sensor Accuracy Evaluations

The FOCSI program included some calibration and environmental testing by the sensor suppliers and engine test data is comparing electrical and optical sensor measurements. However, a detailed accuracy analysis of each sensor system (sensor, cable, and EO circuit) including the effects such as temperature, hysteresis, repeatability, and interchangeability left many unanswered questions. More testing is required to more fully evaluate effects on sensor accuracy.

3. Power Supply Operation

During acceptance testing of the EOU at Litton, considerable time was spent trouble-shooting erratic power supply outputs. The EOU power supply was designed, fabricated, tested, and assembled into the EOU chassis at GE. The power supply outputs measured by Litton were totally unreasonable. It was finally discovered that the power supply grounding wire terminations, only observable by removing the fiber optic flame detector module, were not making good contact with the chassis grounding lugs to which they should have been soldered. Good quality control practices must be followed.

4. Screening Advanced Technology Components

Advanced technology custom 1X2 fiber optic couplers were procured for use in the optical CVG rotary position sensors and in the optical T2.5 probe cables. Desirable unique features included a very small package size and a temperature rating of from -25° to 150° C. They were fabricated on a best effort basis, and there were some failures during component testing. To insure quality, a shipment requirement should be 100% acceptance testing, in this case, thermal cycling and perhaps tensile loading. **Lesson:** Perform 100% acceptance testing on advanced technology custom components.

11.5 SYSTEM INTEGRATION

1. Electro-Optic Interference

Some sensors signals require very high gain amplification immediately following the optical detector because of , for example, a very small optical modulation depth. The detector output current can therefore be very small and susceptible to radiated/conducted interference from the surrounding circuitry, such that the amplifier output is saturated, and the signal is lost. **Lesson:** Careful integration between the sensor supplier and the electro-optics designer is required early in the program.

12.0 CONCLUSIONS

The subject of this report is to describe the work done under NASA Contract NAS3-25805, that is, the development of a fiber optic sensing system designed to measure nine parameters on a F404-400 turbofan engine during flight testing. The results are to be used to help validate fiber optic technology towards eventual engine product application.

As of completion of the engine ground testing, all nine sensor signals are being monitored from the Electro-Optics Unit to greater or lesser degrees of performance. Sensors, cables, and signal conditioning circuitry all contribute to the measurement. Following are general comments on important issues associated with the present status of development.

Many fiber optic sensing techniques are extremely accurate on a single sensor basis. However, **sensor manufacturing repeatability** must be improved such that characteristics which affect accuracy are sufficiently uniform. Sensor-to-sensor accuracy differences must fall within an allowable tolerance. For production, it must be possible to replace a sensing unit without adjusting any other part of the measurement system, and achieve acceptable performance results. The sensing unit and the signal conditioning circuit must not have to be maintained as a matched set. This especially applies to position and temperature sensors where the signal conditioning employs software calibration. Sensor suppliers have been made aware of this issue.

Some fiber optic sensing components do not meet performance requirements over the specified **temperature range**, and others that do, have uncomfortably little margin. Electro-optic components must be capable of adequate

performance rating over the full MIL-Spec range of -55 to 125° C. Epoxies are typically used in fiber optic assemblies for purposes of, for example, accurately aligning optical pieceparts. Locking fasteners are more commonly used for structural purposes in engine component packaging. New techniques will need careful evaluation for long life performance over the typical -55 to 200°C environment. Calibration shifts over the temperature range must fall within an acceptable band.

Fragility and contamination are real world, practical issues. Once the fiber is enclosed inside a temperature-stable, crush-resistant, bend radius-controlled conduit, survivability in the engine assembly environment is high. Cleanliness in preparing and handling the present fiber optic interface designs cannot be over emphasized. Contamination generated from position sensor sliding surfaces and the effects of fuel/oil needs more evaluation.

Fiber optic technology is recognized for providing **electromagnetic interference** immunity with respect to the interconnections between sensor and circuitry assemblies. However, within the electrical control unit, some electro-optic circuitry may be significantly sensitive to typical radiated and conducted interference. The solution may require new design and testing considerations for successful integration.

This program has generated significant progress in the development, demonstration, and experience base of applying fiber optic technology to aircraft engine control systems. Some measurement methods have displayed a high level of performance and maturity, others require considerable improvement. Flight testing will help clarify strengths/weaknesses in a real service environment. The follow-on program, using a set of fiber optic sensors and electro-optic circuitry in closed-loop engine control, will force continued and substantial quality improvements.

APPENDIX-A

SUPPLIER SELECTION

1. SENSOR SUPPLIER SOLICITATION

For the nine sensors to be demonstrated, solicitation packages were sent to 23 potential suppliers. Each package contained a statement of work, performance/environmental requirements, form factor sketches, a representative test plan, a program schedule, and a request for specific technical information including interface characteristics.

Proposal responses were required to contain a technical section describing the proposed approach, available resources, response to the statement of work, and past experience, and a cost section describing a detailed cost breakdown, expenditure schedule, and cost sharing commitment.

Weighted criteria were used to evaluate and rank the responses technically. The criteria included: ability to meet the design requirements, method of accomplishment, present developmental level, special features and attributes, related experience, and available resources.

The following 18 suppliers provided proposals for one or more of the 9 sensors:

Allied Signal
Ametek Aerospace
Armtec Industries
Aurora Optics
Babcock & Wilcox

Banks Engineering & Labs
BEI Motion Systems
Computer Optical
Conax Buffalo
Kearfott
Litton Poly-Scientific
Luxtron Corporation
MetriCor
Norwich Aero. Products
Optical Technologies
Rosemount Aerospace
Simmonds Precision
Teledyne Ryan

2. EOA DESIGNER/INTEGRATOR SUPPLIERS

For the design, fabrication, testing, of board-mounted, integrated electro-optic circuitry associated with the set of sensors to be demonstrated, solicitation packages were sent to 7 potential suppliers. Emphasis was on providing design commonality and multiplexing. Package content, proposal response requirements, and evaluation criteria were very similar to those for the sensors as described above. The following 5 suppliers provided proposals for this work:

Allied Signal
Ametek Aerospace
GEC Avionics
Litton Poly-Scientific
Teledyne Ryan

APPENDIX-B
HARDWARE PHOTOGRAPHS

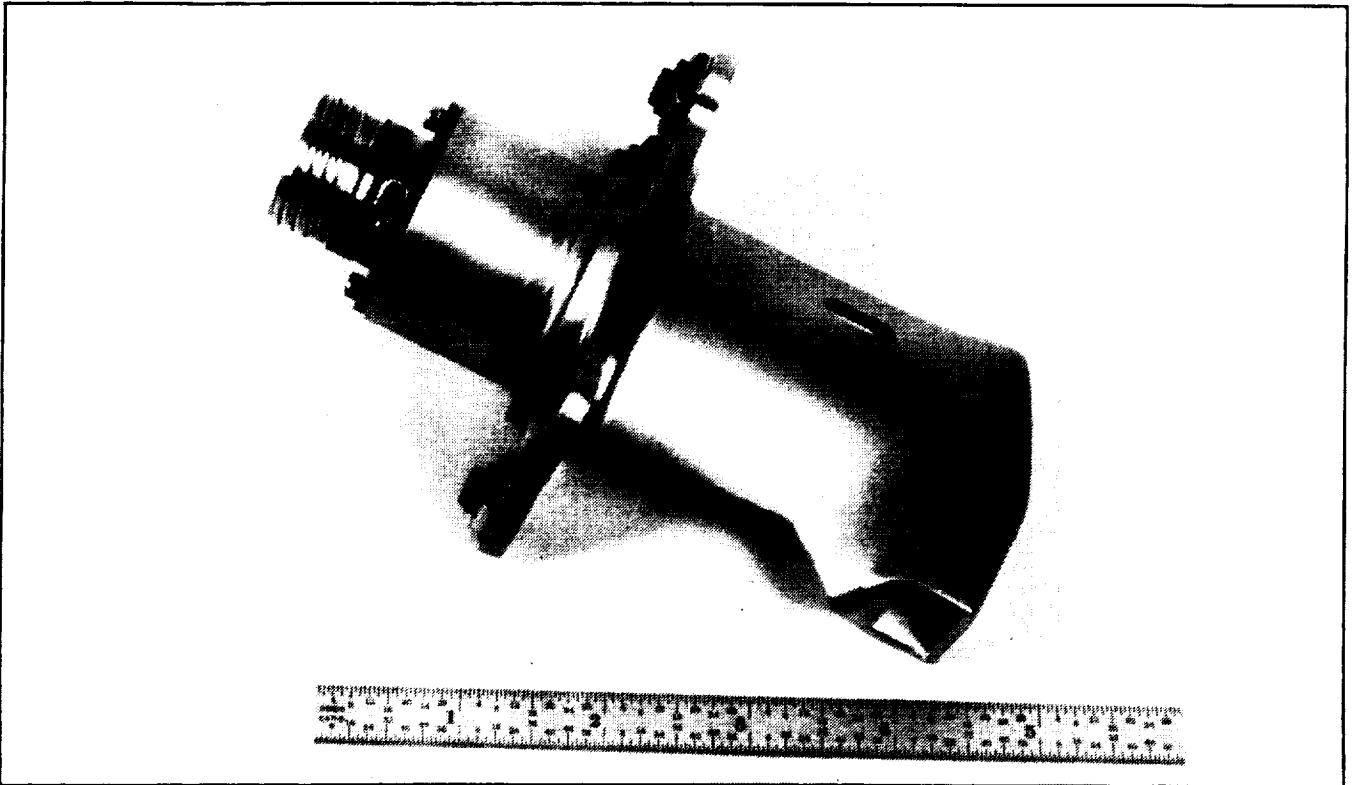

Figure 34 - Fiber Optic T1 Temperature Sensor

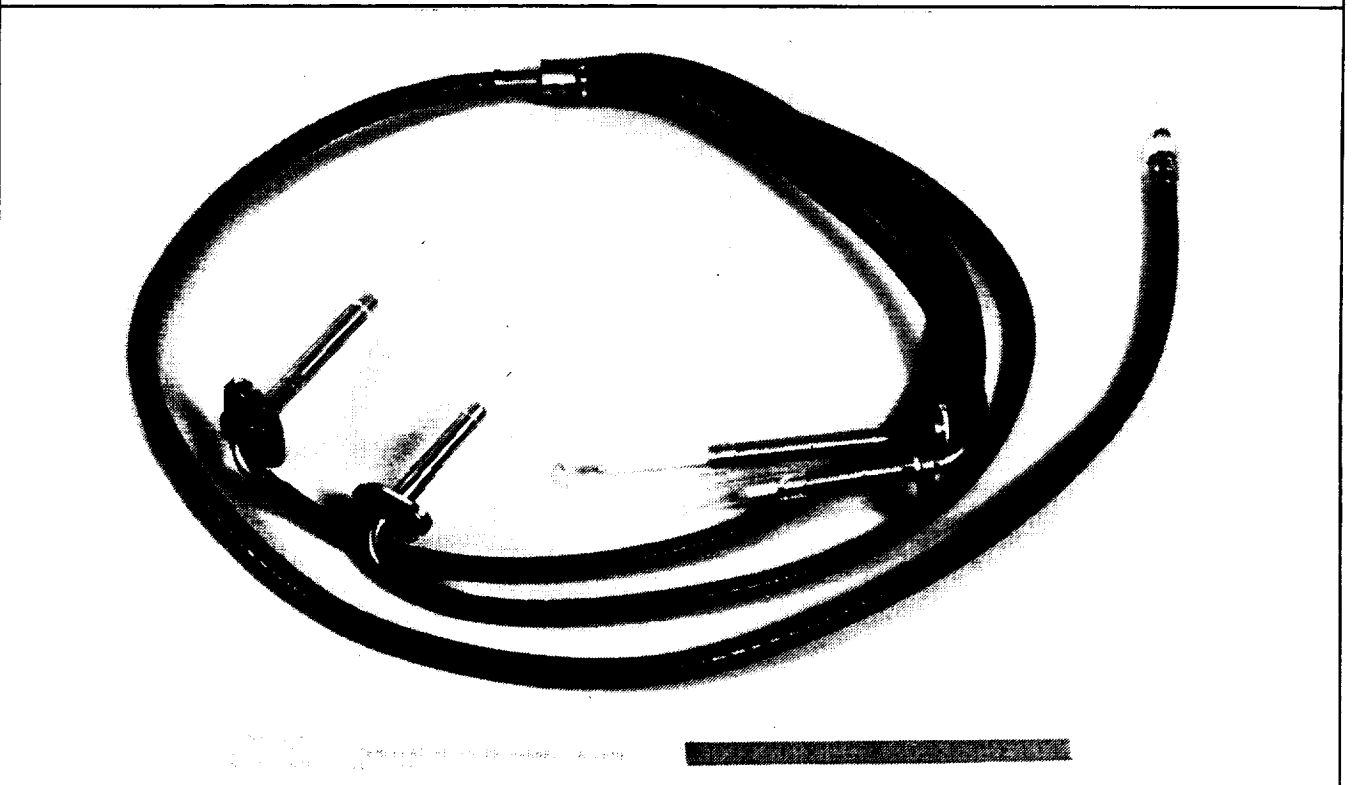

Figure 35 - Fiber Optic T5 Temperature Probe/Harness Assembly

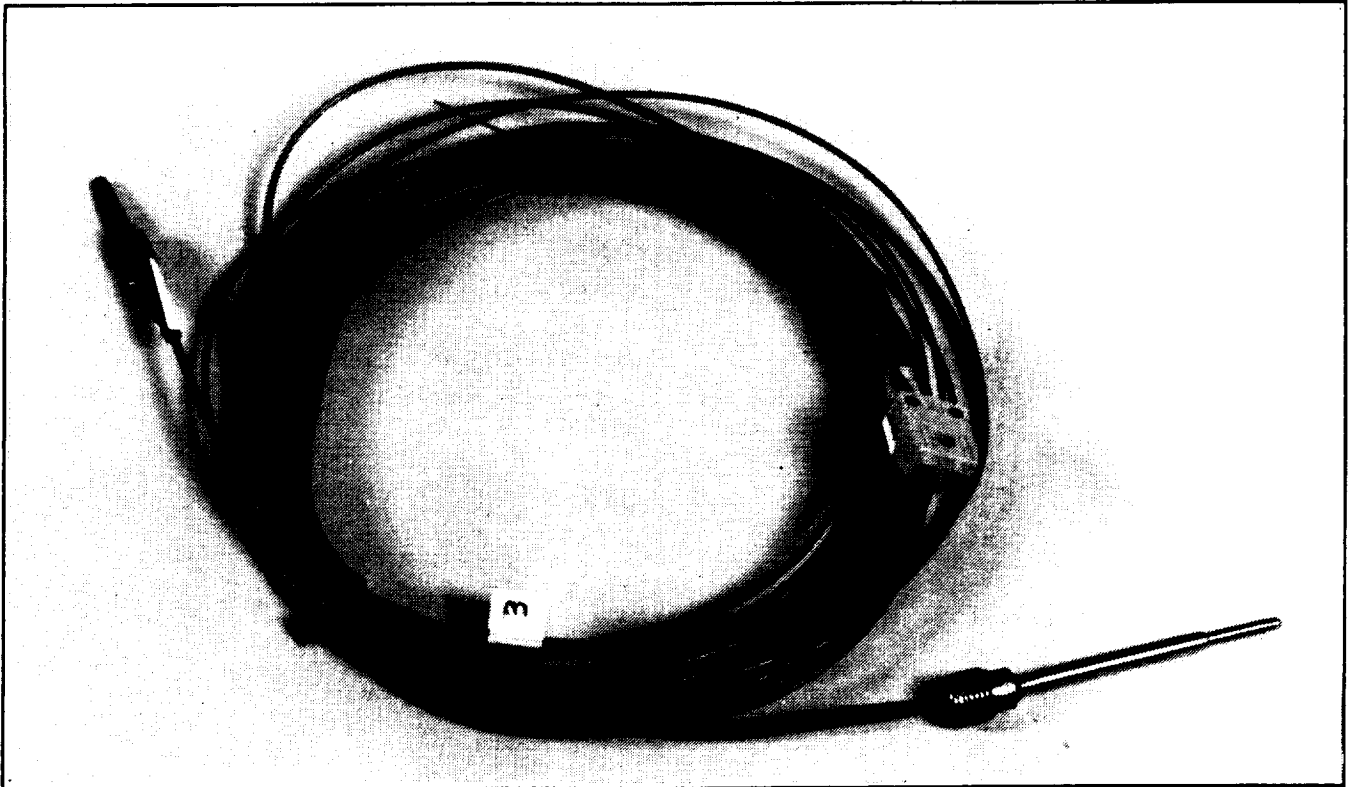

Figure 36 - Combined Fiber Optic-T/C T2.5 Temperature Probe/Cable, Unpackaged

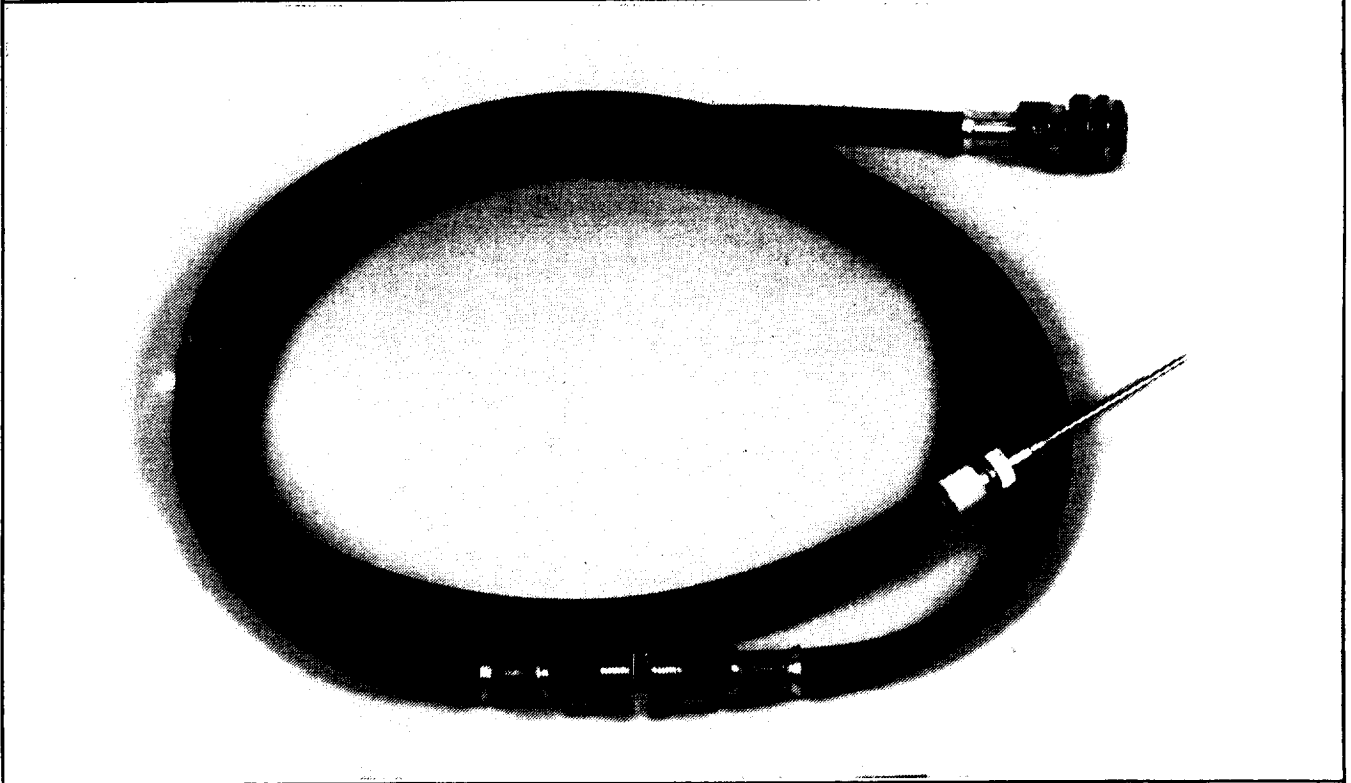

Figure 37 - Packaged T2.5 Temperature Probe Assembly

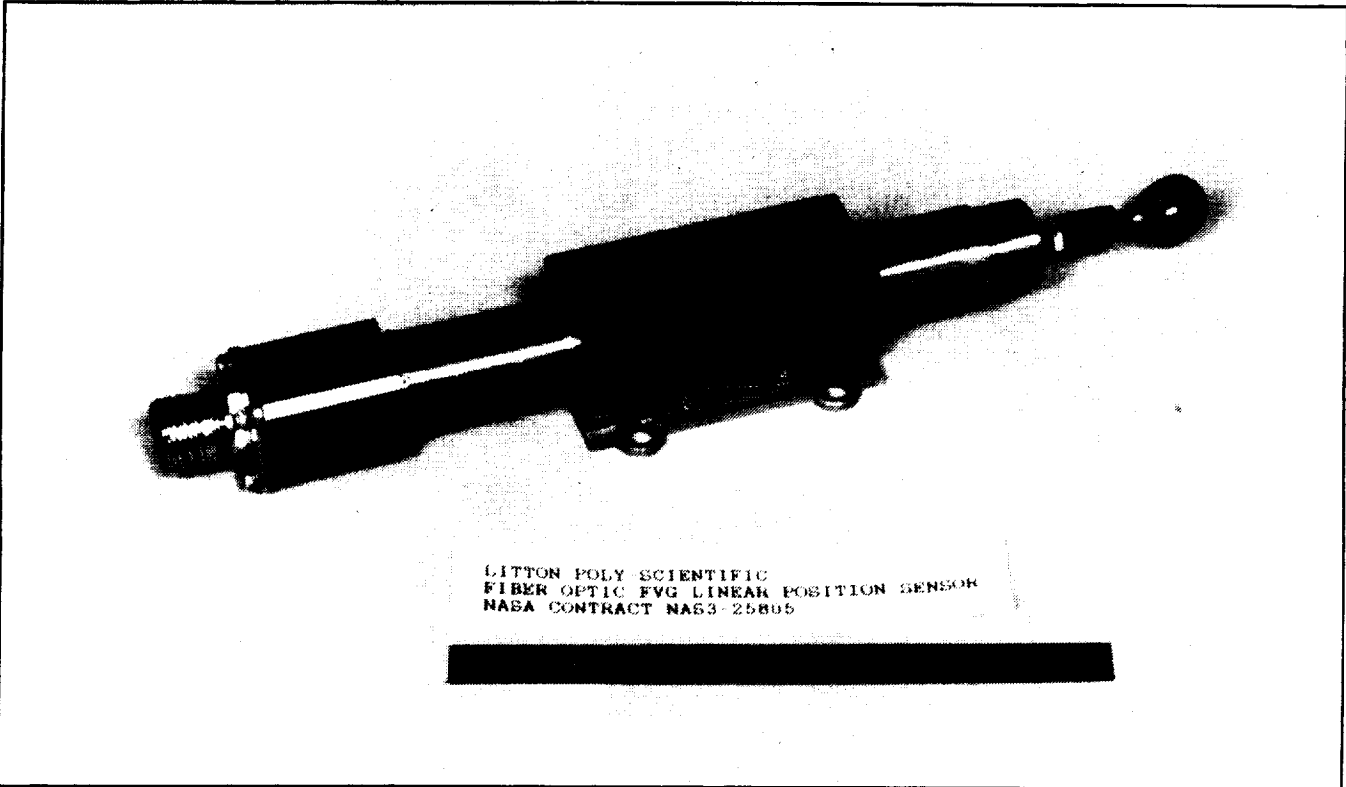

Figure 38 - Fiber Optic FVG Position Sensor

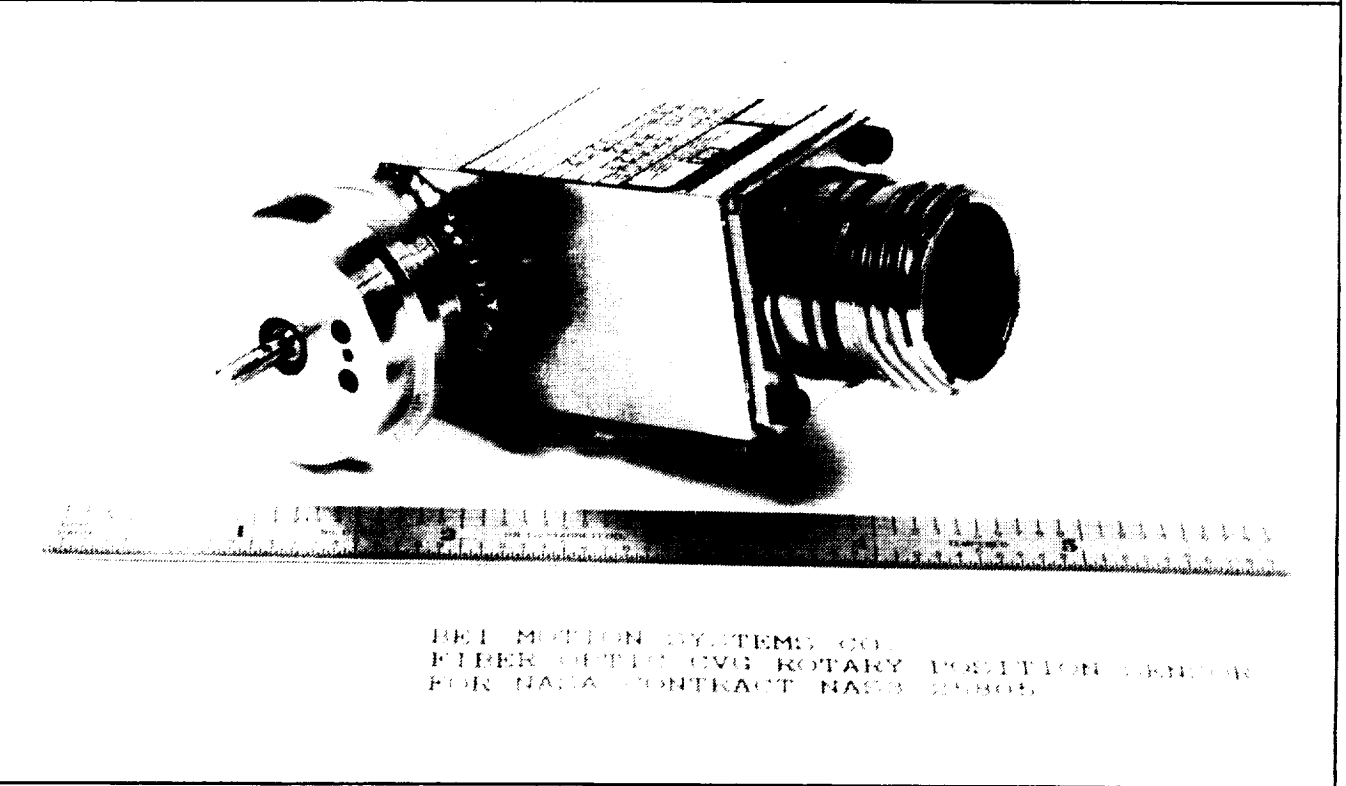

Figure 39 - Combined Fiber Optic/Potentiometer CVG Position Sensor

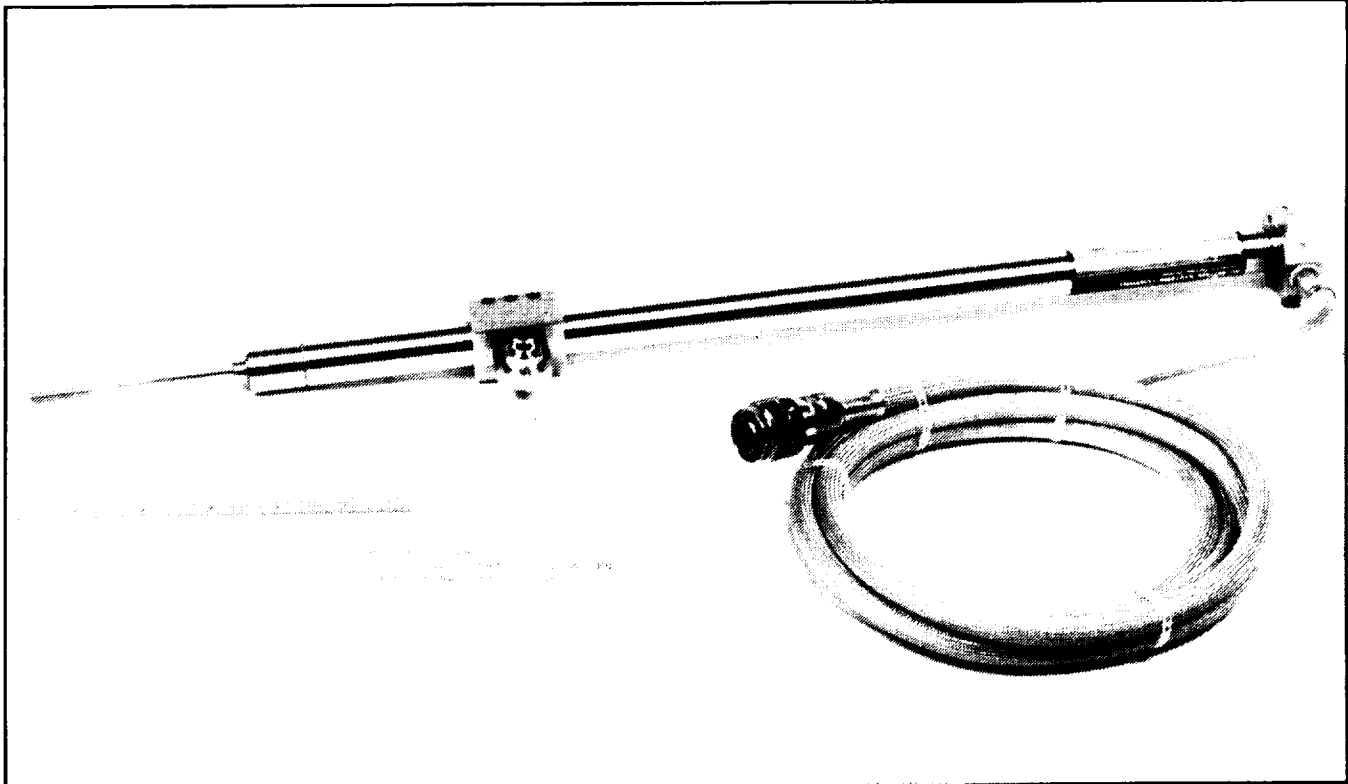

Figure 40 - Fiber Optic VEN Position Sensor

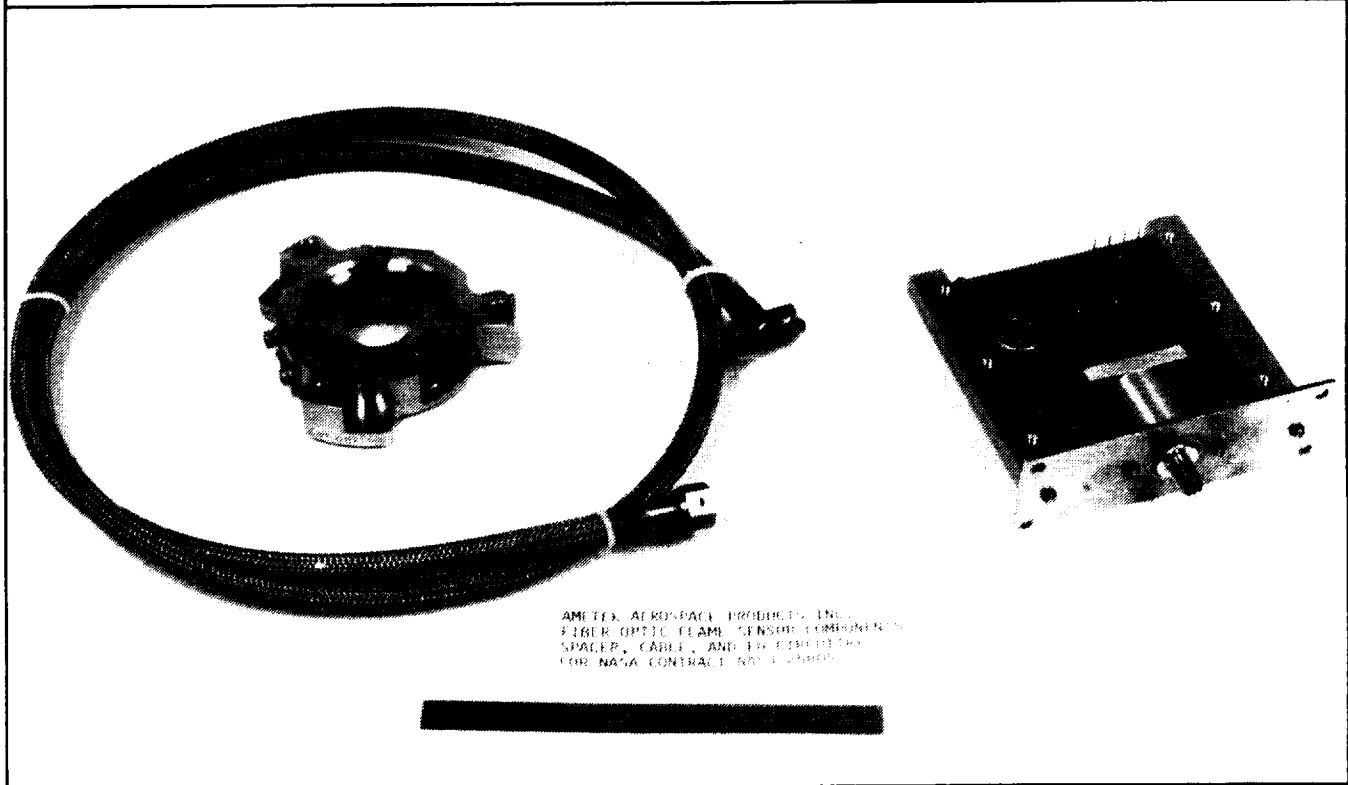

Figure 41 - Fiber Optic Flame Detector Spacer, Cable, and Detector Assembly

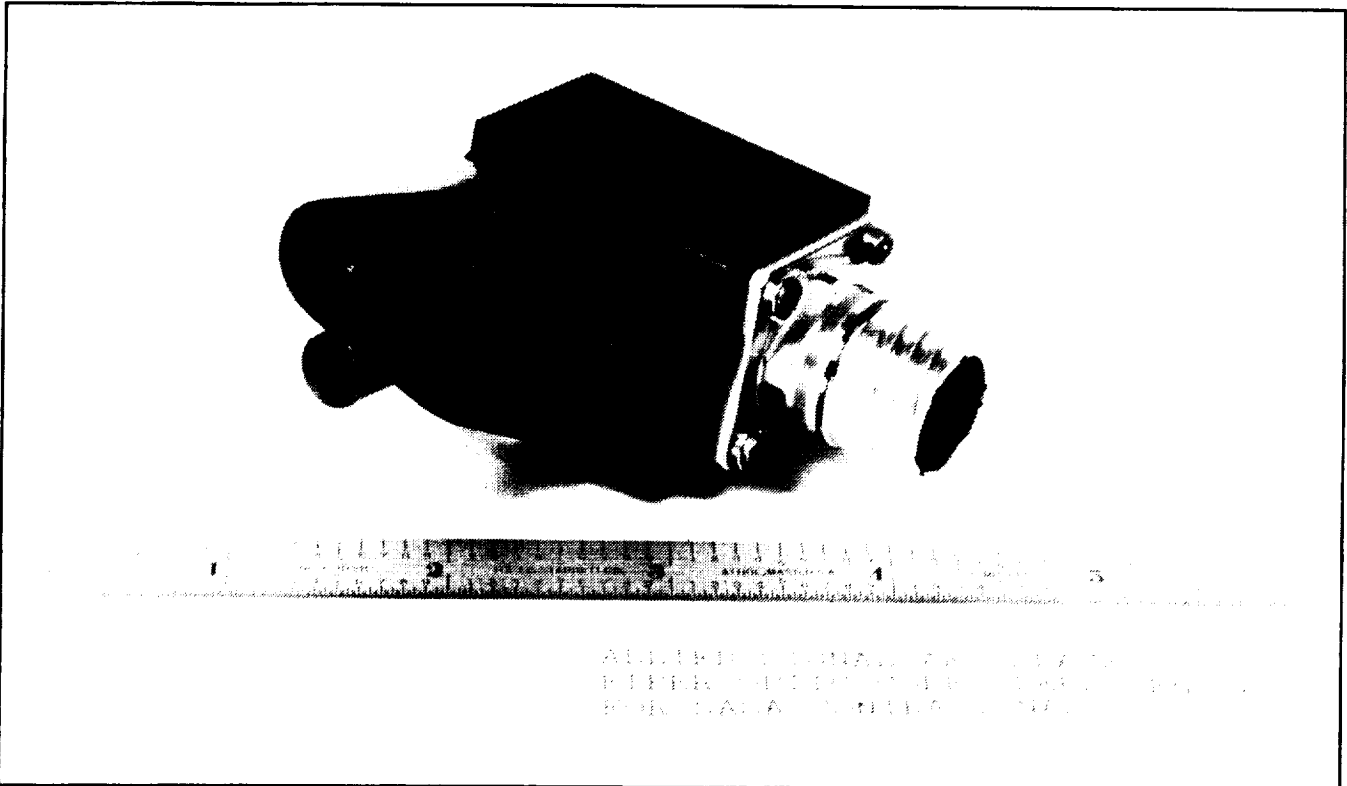

Figure 42 - Fiber Optic NH Speed Sensor

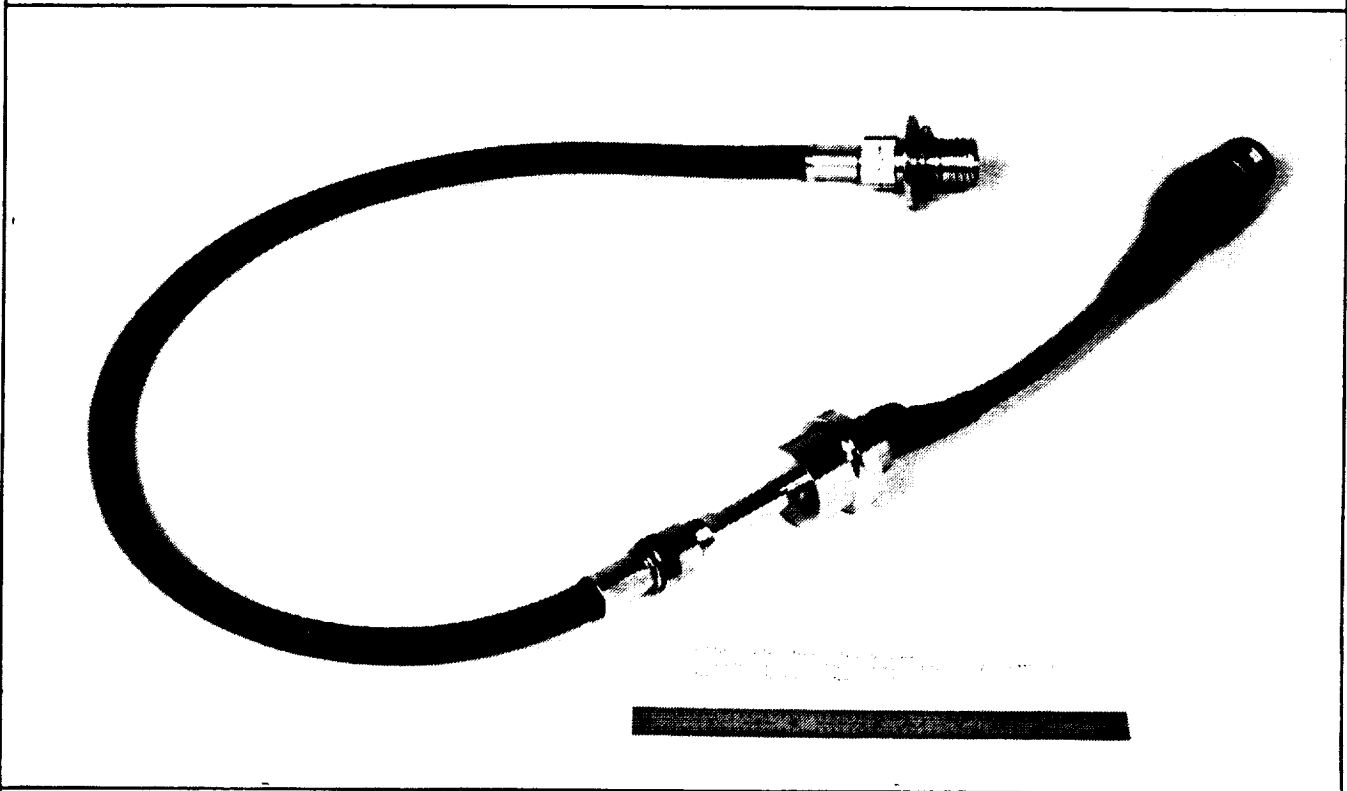

Figure 43 - Fiber Optic NL Sensor and Cable Pigtails

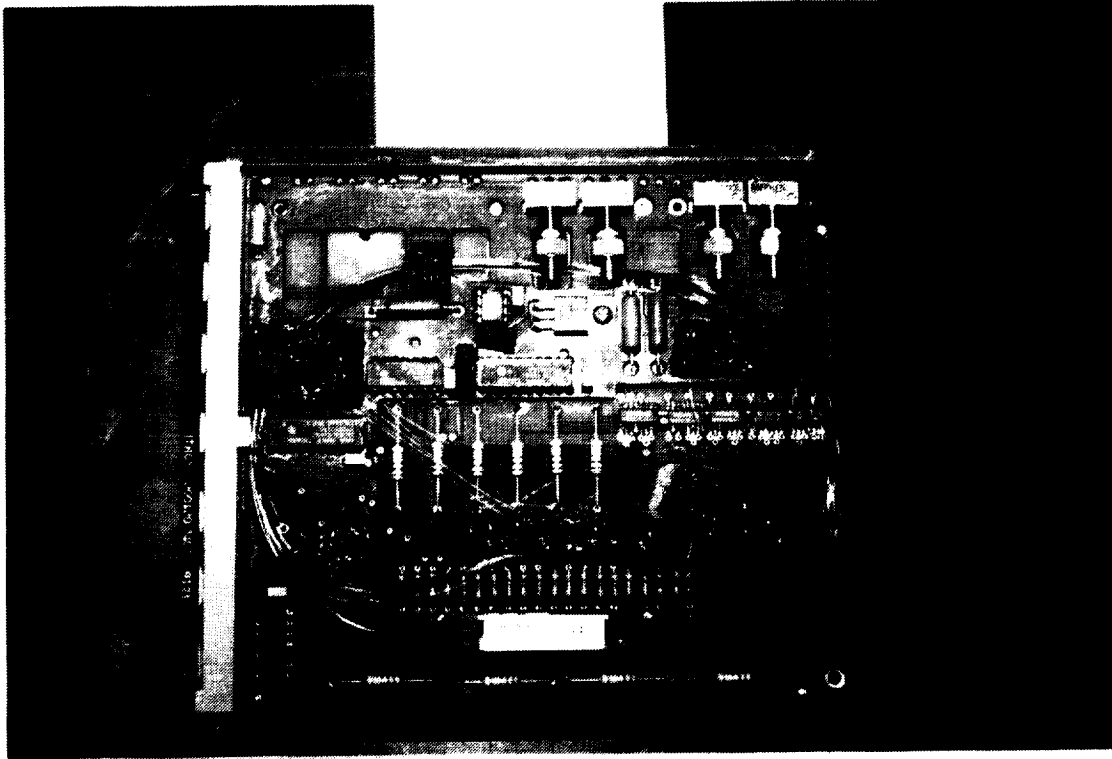

Figure 44 - WDM Source Board

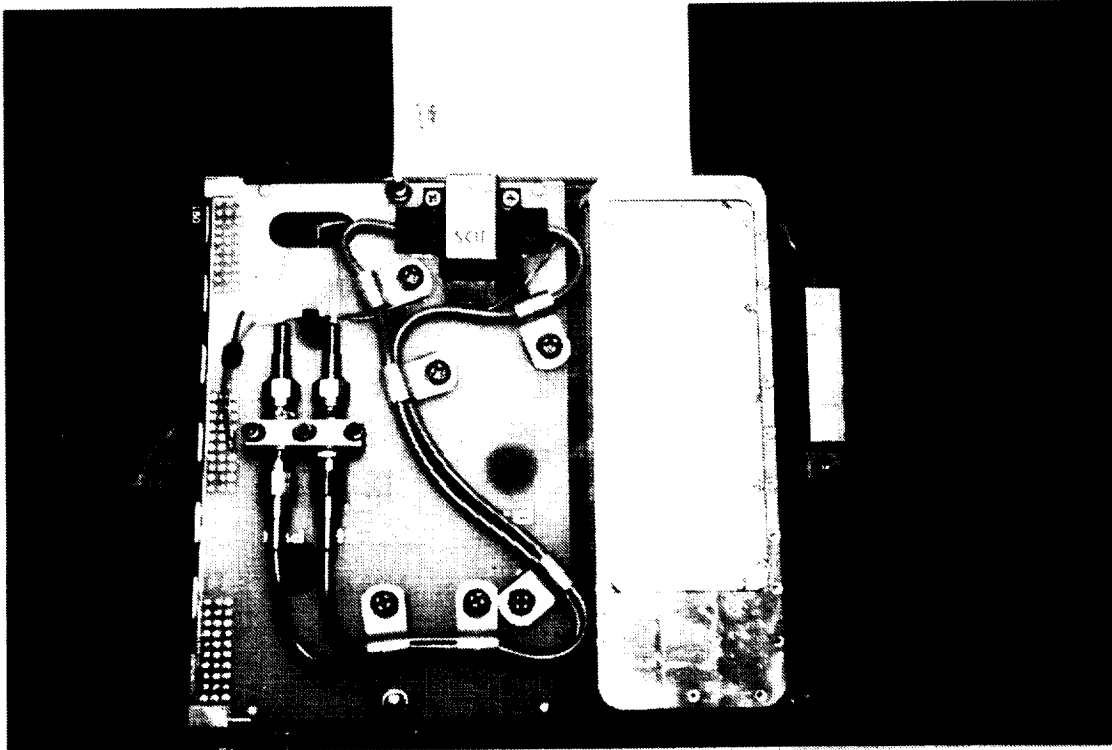

Figure 45 - WDM Optics Receiver Board

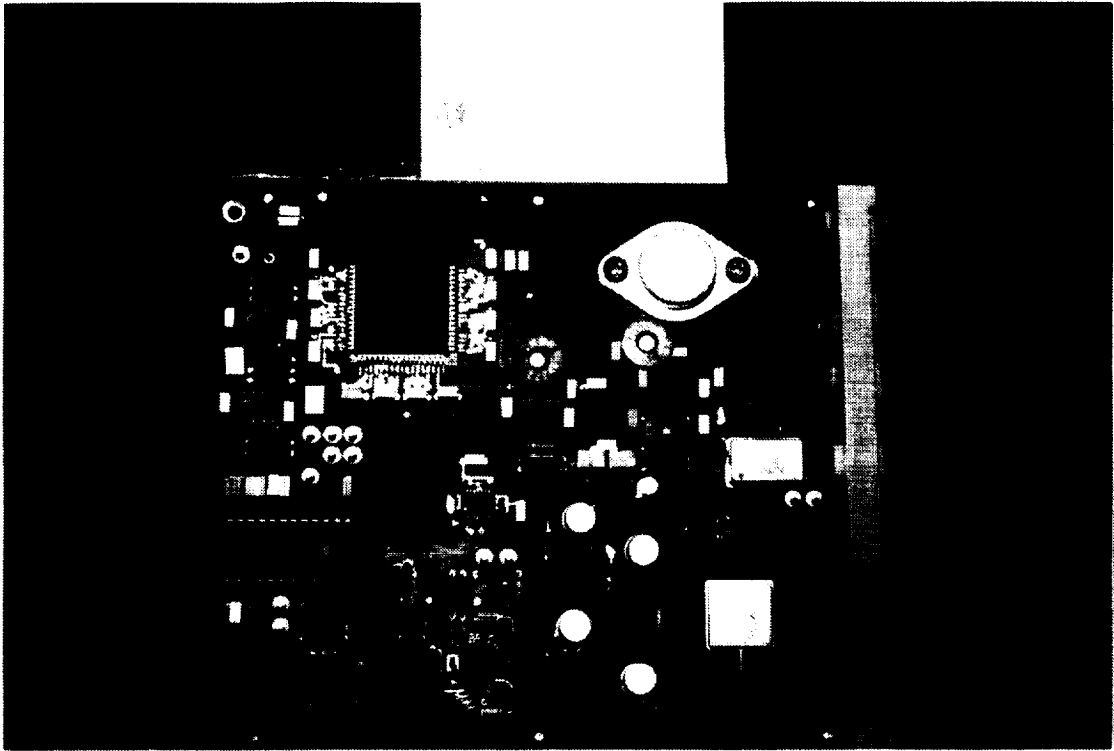

Figure 46 - WDM Electrical Receiver Board

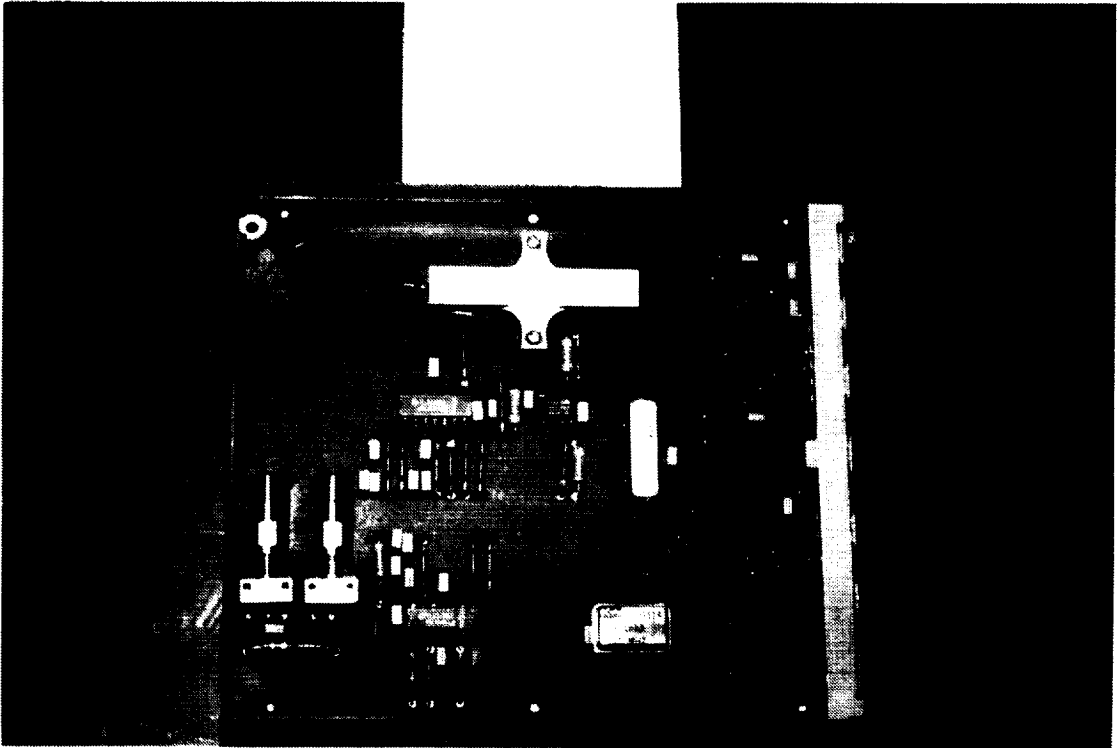

Figure 47 - Electro-Optics Board For Optical NL Sensor

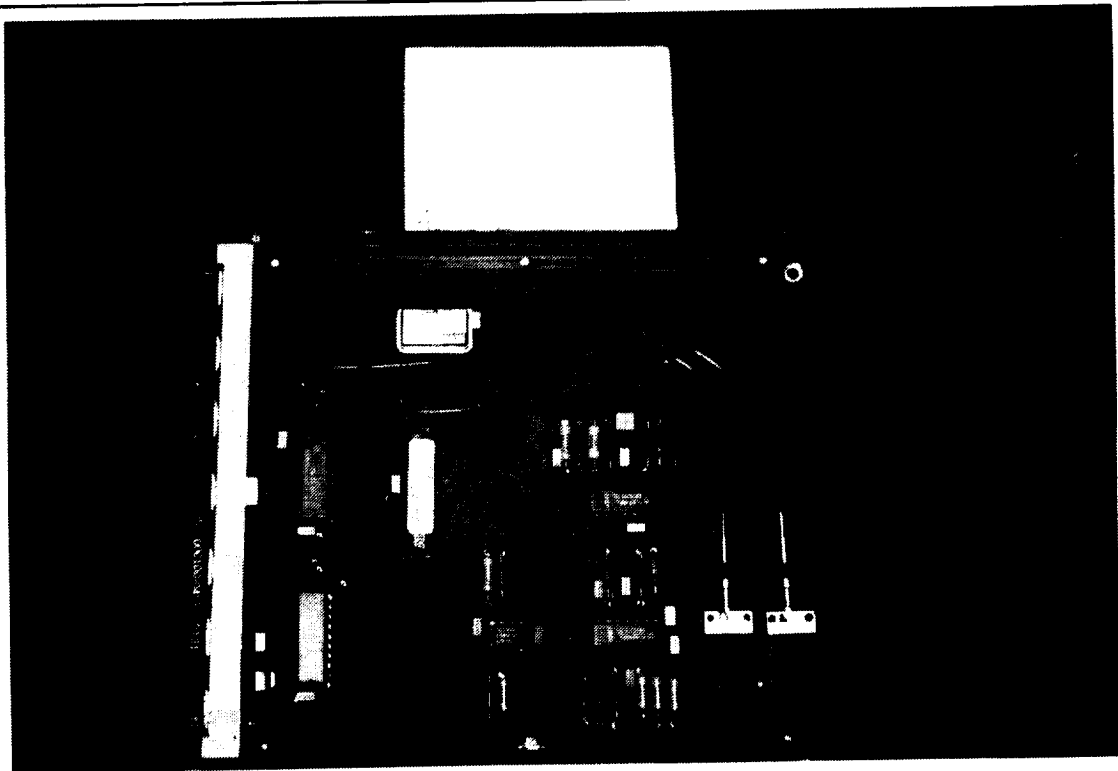

Figure 48 - Electro-Optics Board For Optical NH Sensor

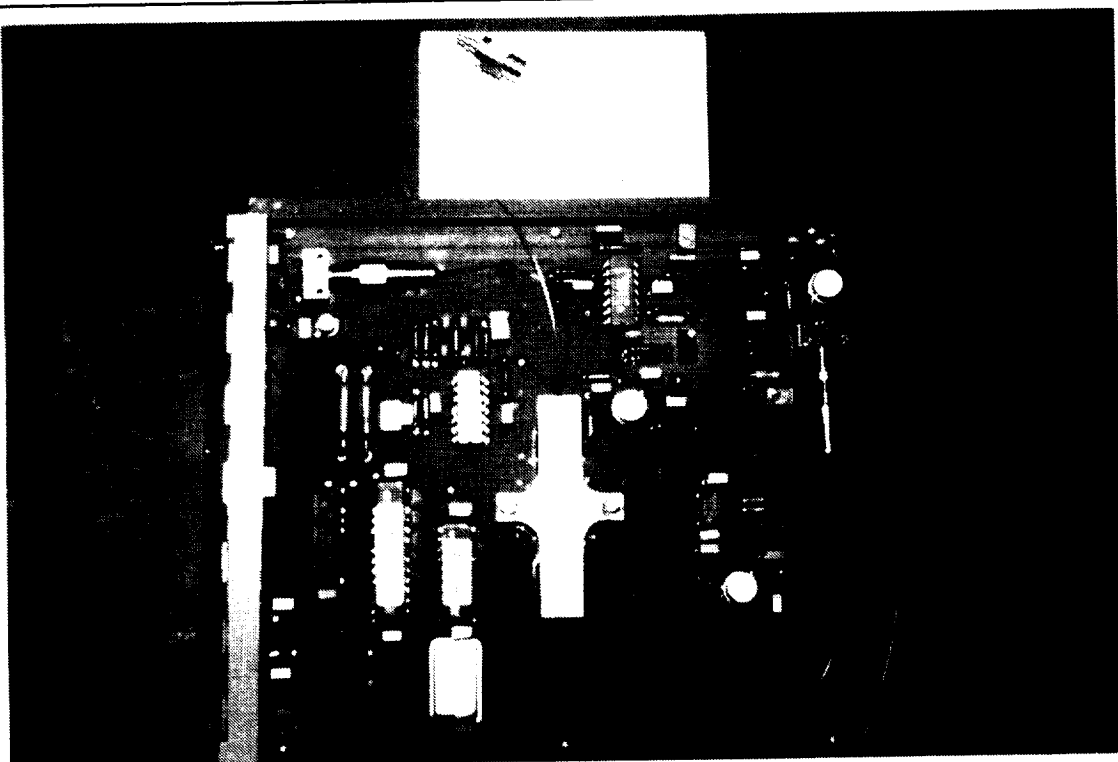

Figure 49 - Electro-Optics Board For TRD Sensor

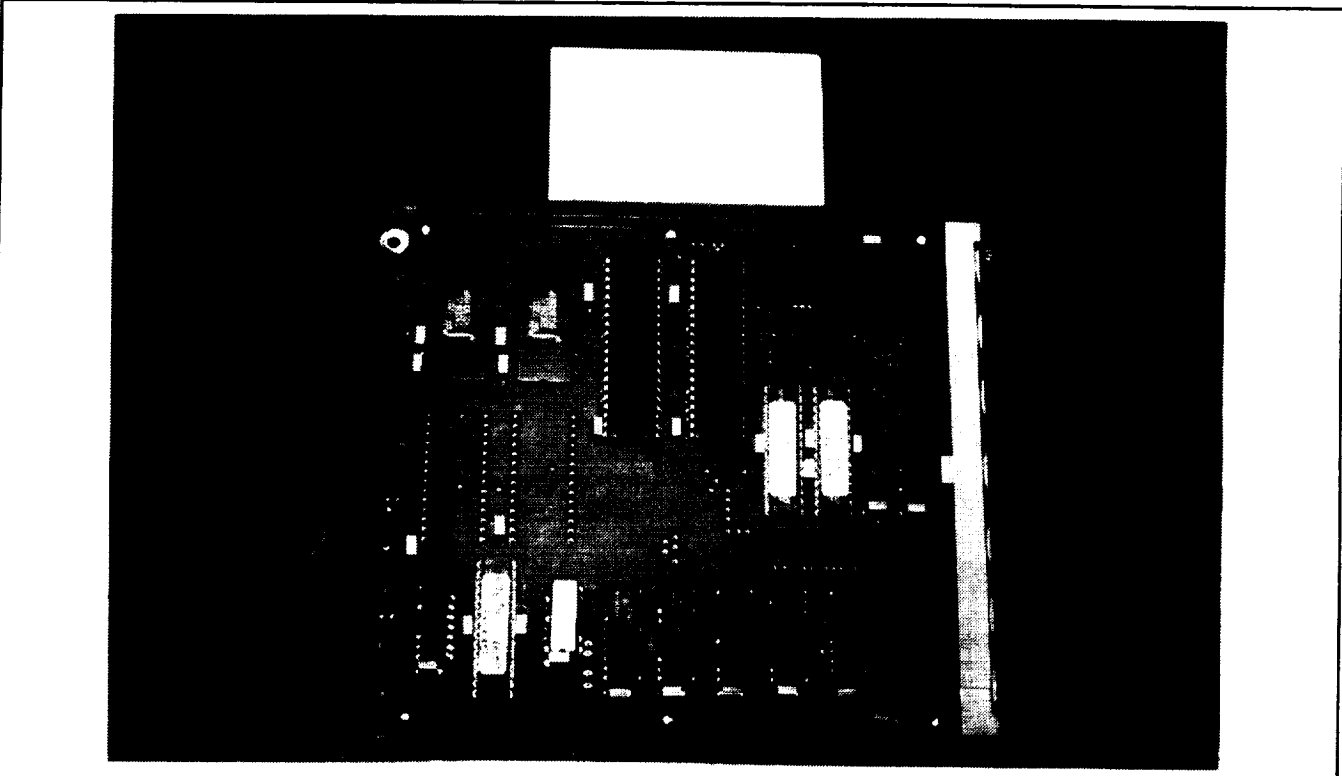

Figure 50 - Data Acquisition (DAC) Board

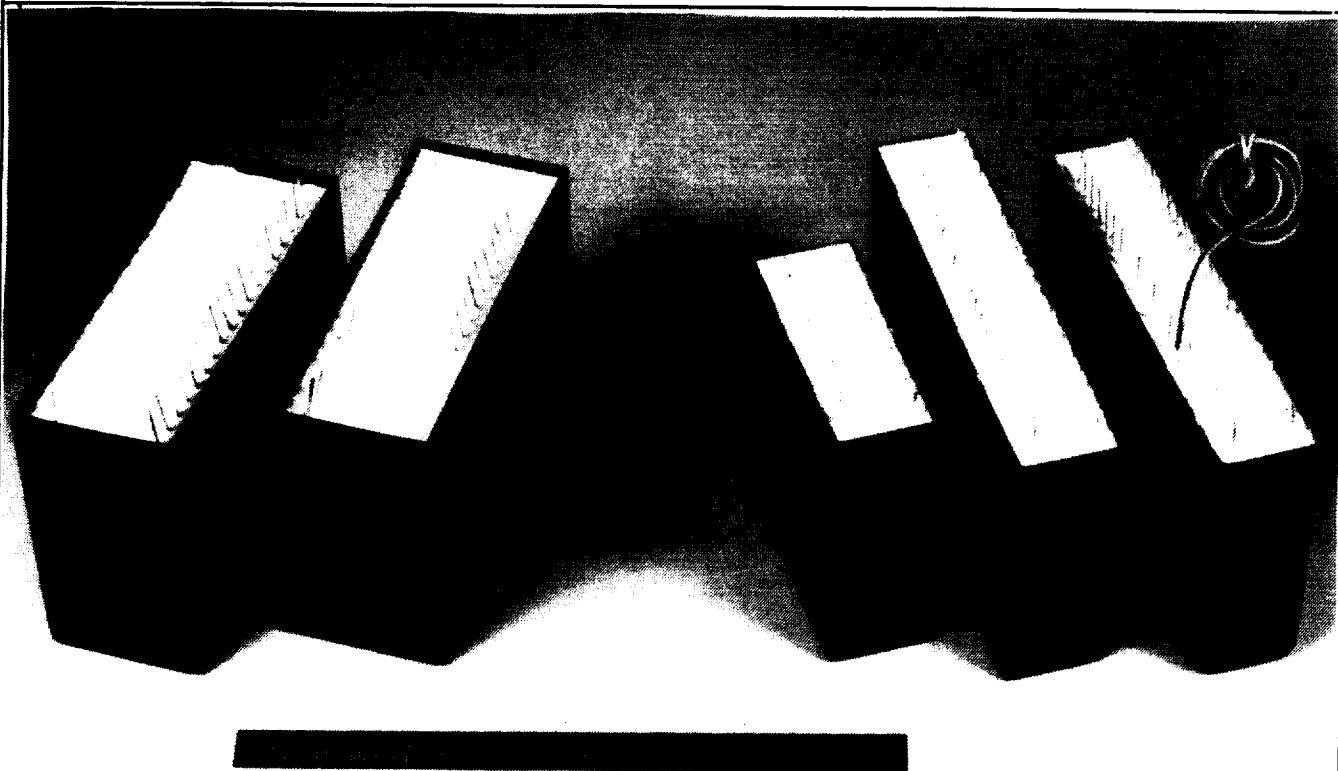
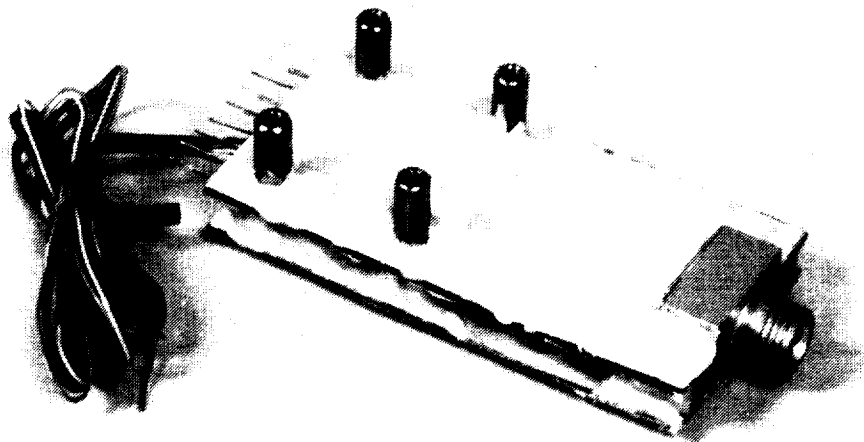
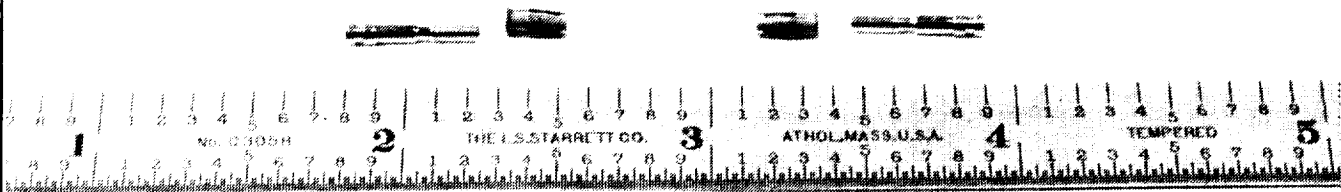

Figure 51 - GE Power Supply and Electrical Sensor Signal Conditioning Modules



CONAX BUFFALO
ELECTRO-OPTIC MODULE FOR
FIBER OPTIC T5 PROBE/HARNESS ASSEMBLY
NASA CONTRACT NAS3-25805

Figure 52 - Conax T5 Sensor Signal Processing Board Assembly



G&H TECHNOLOGY, INC.
FIBER OPTIC TERMINUS ASSEMBLY
FOR SEM CONNECTORS AT EOU BACKPLANE
NASA CONTRACT NAS3-25805

Figure 53 - G&H Expanded Beam Fiber Optic Terminus Assemblies For Routing Through Backplane

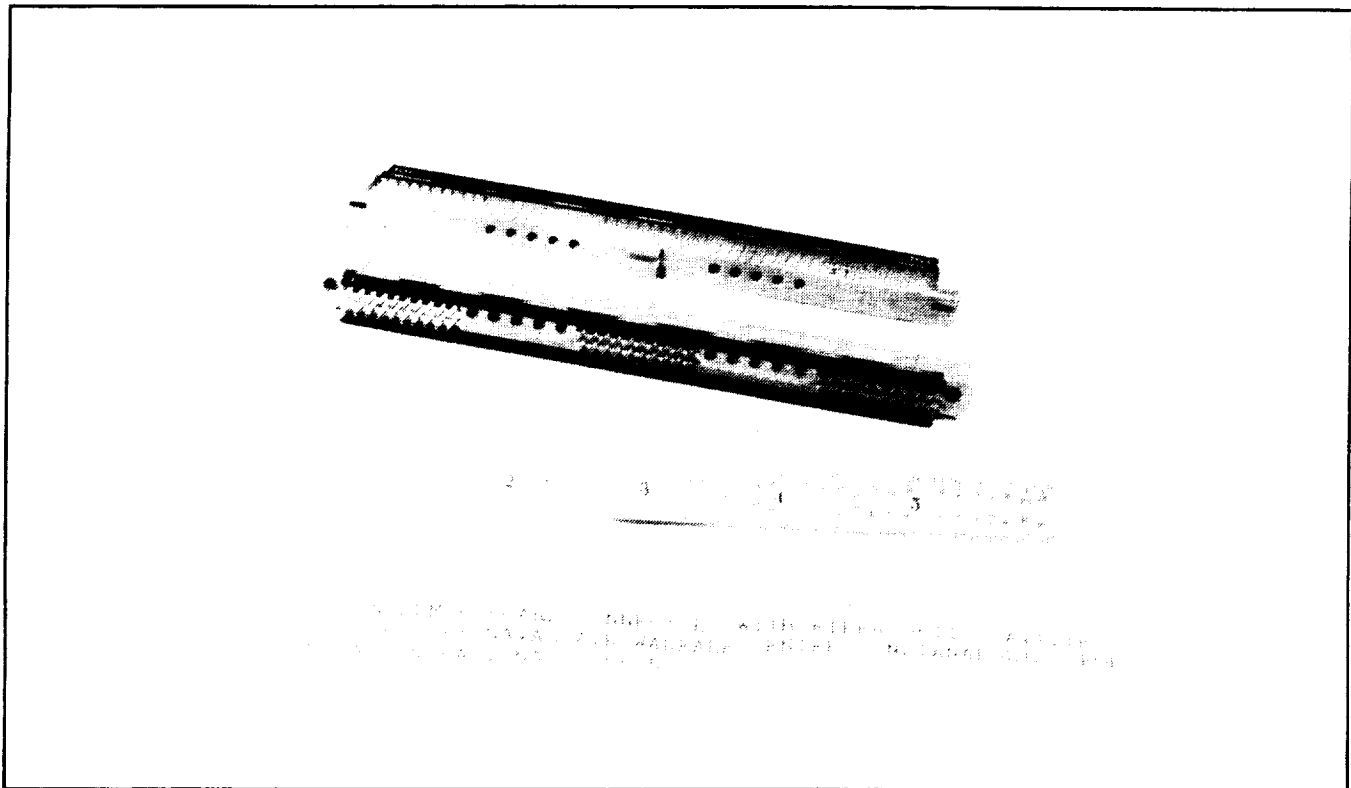
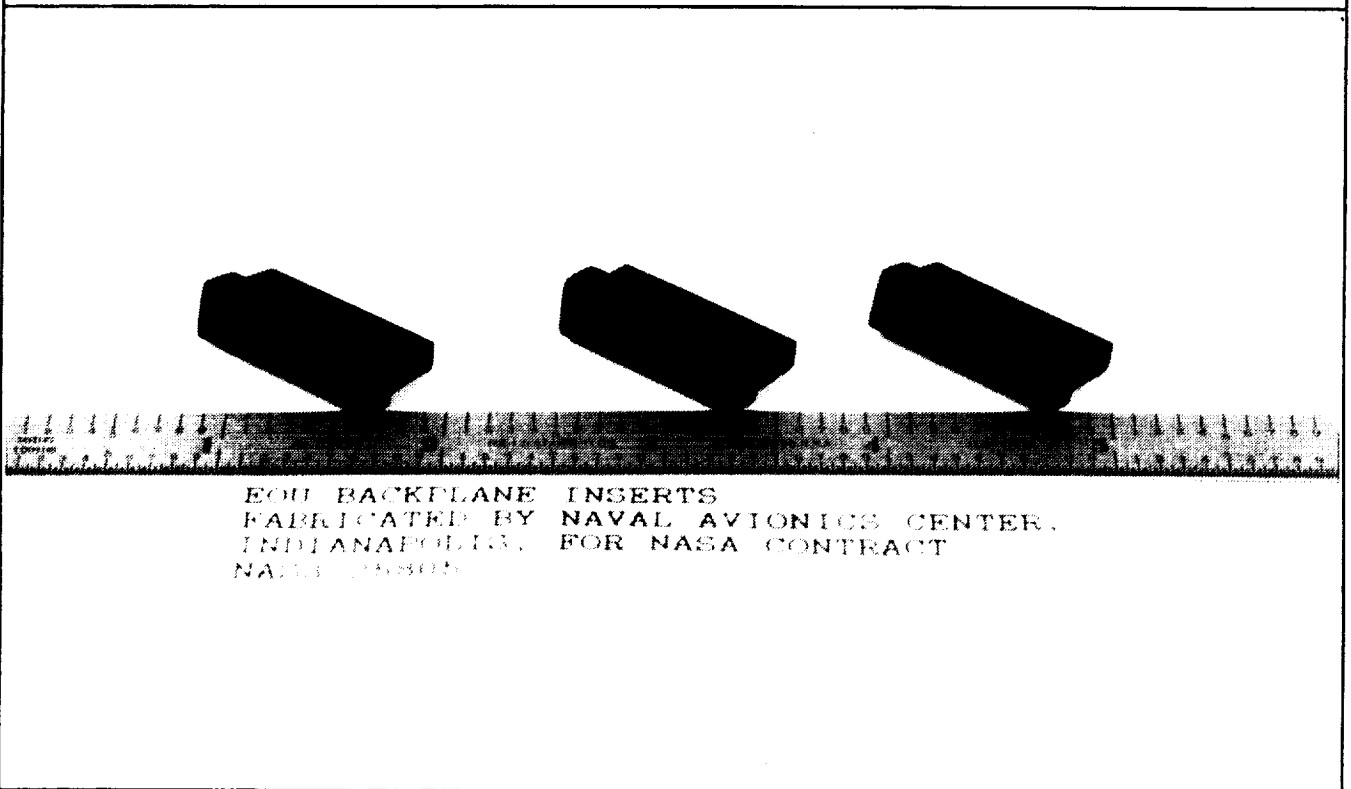

Figure 54 - SEM-E Board Connectors With Fiber Optic Cavities For G&H Termini



EQI BACKPLANE INSERTS
 FABRICATED BY NAVAL AVIONICS CENTER,
 INDIANAPOLIS, FOR NASA CONTRACT
 NAL-10-5800

Figure 55 - Machined Inserts For Support of G&H Termini In Backplane

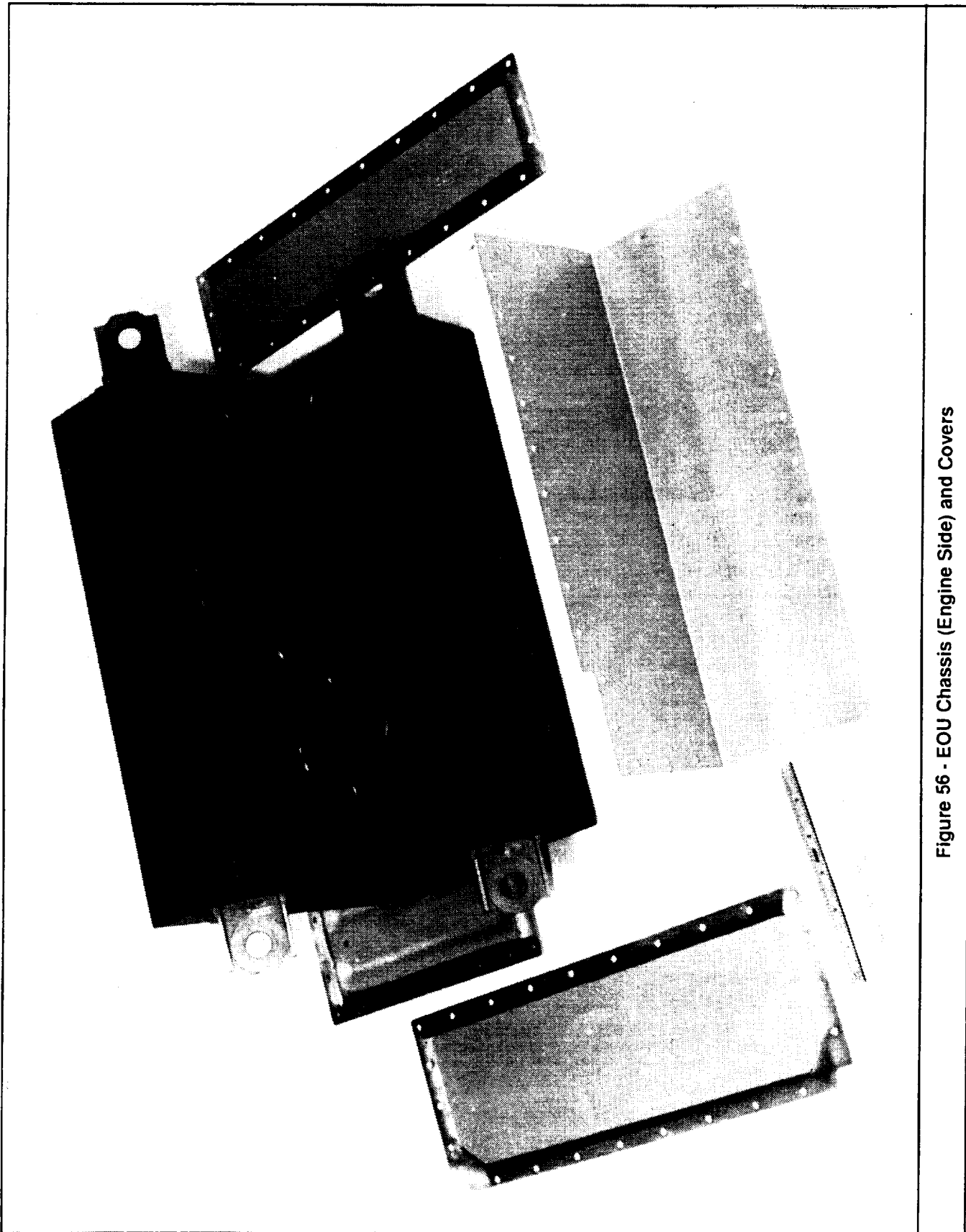

Figure 56 - EOU Chassis (Engine Side) and Covers

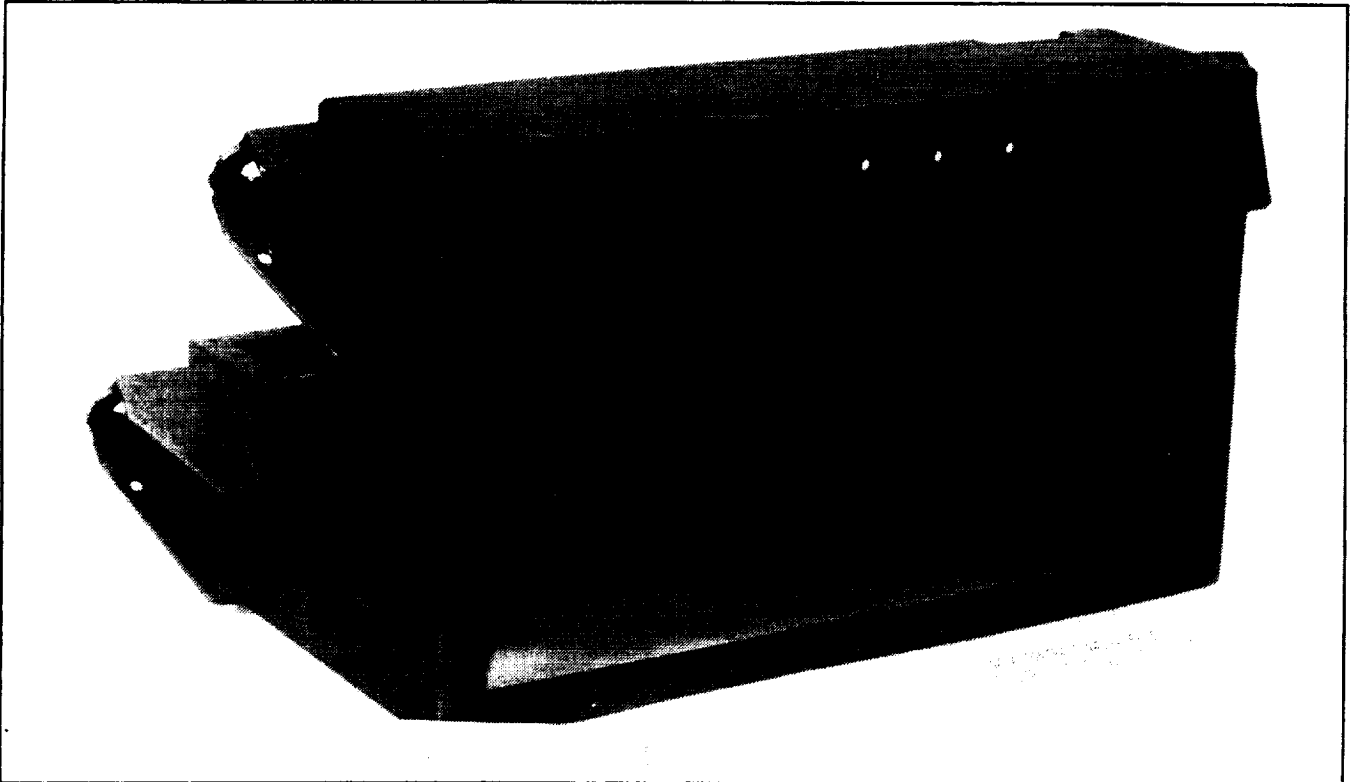

Figure 57 - Side of EOU Chassis Showing Cavities For Module/Board Installation

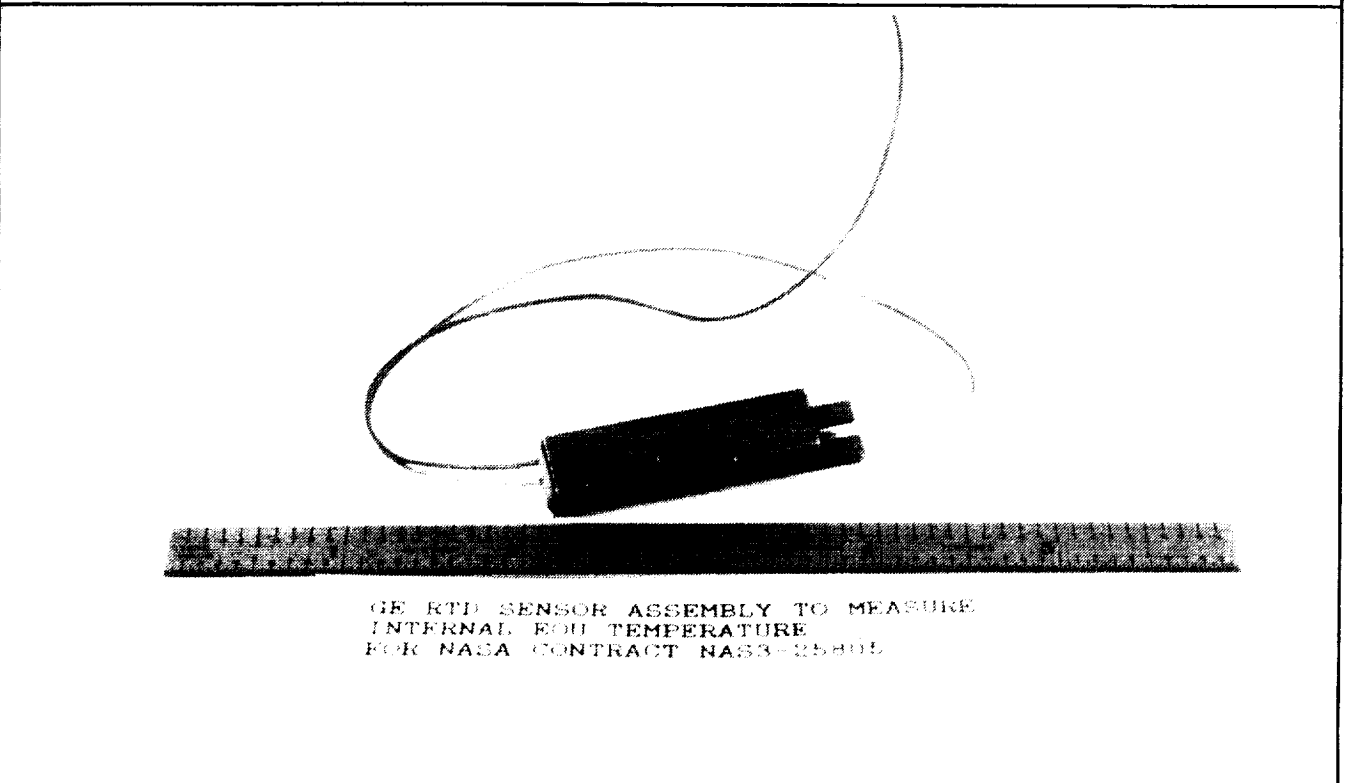

Figure 58 - RTD For Internal EOU Temperature Measurement

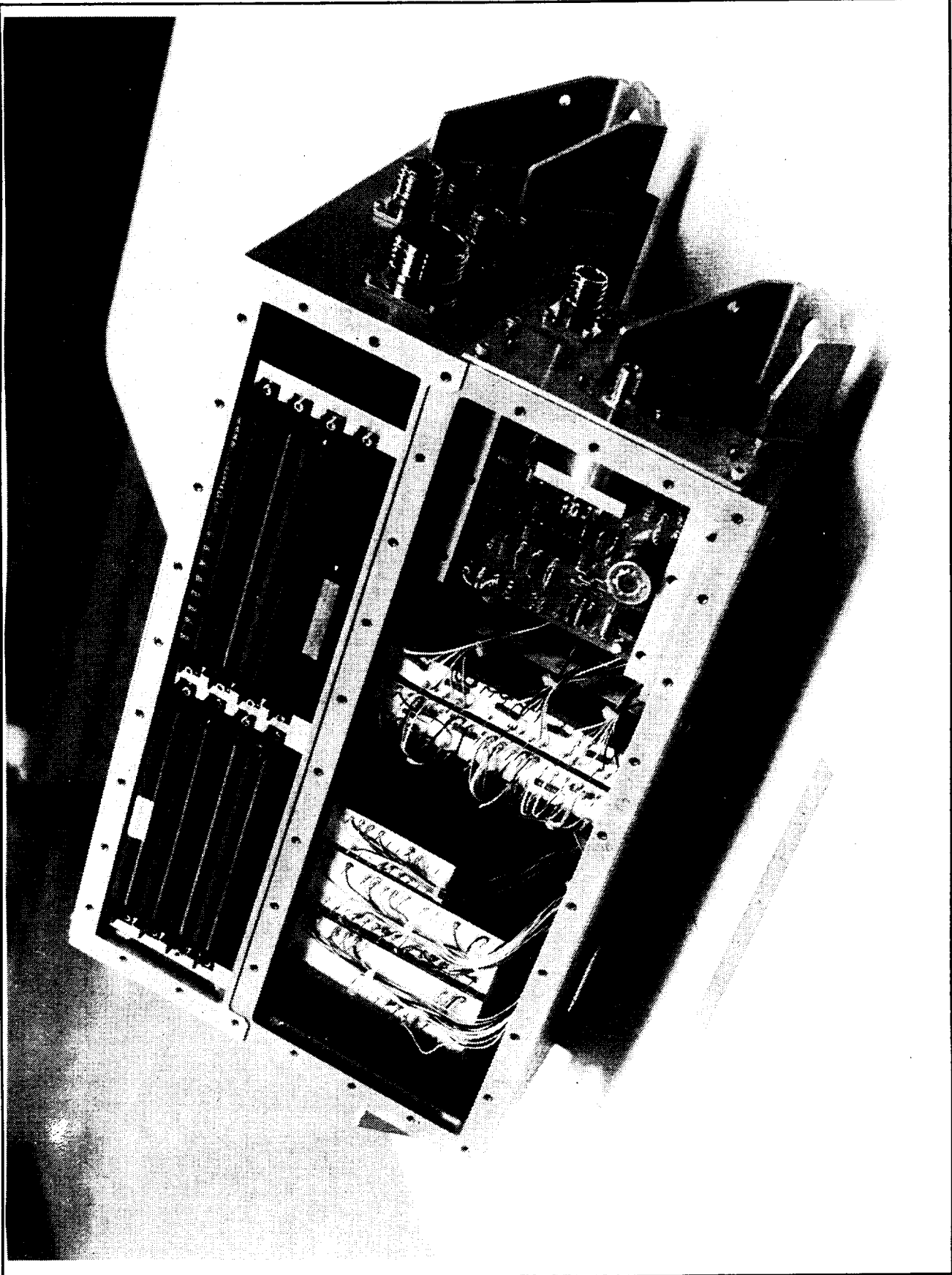

Figure 59 - EOU Assembly With Side Cover Removed

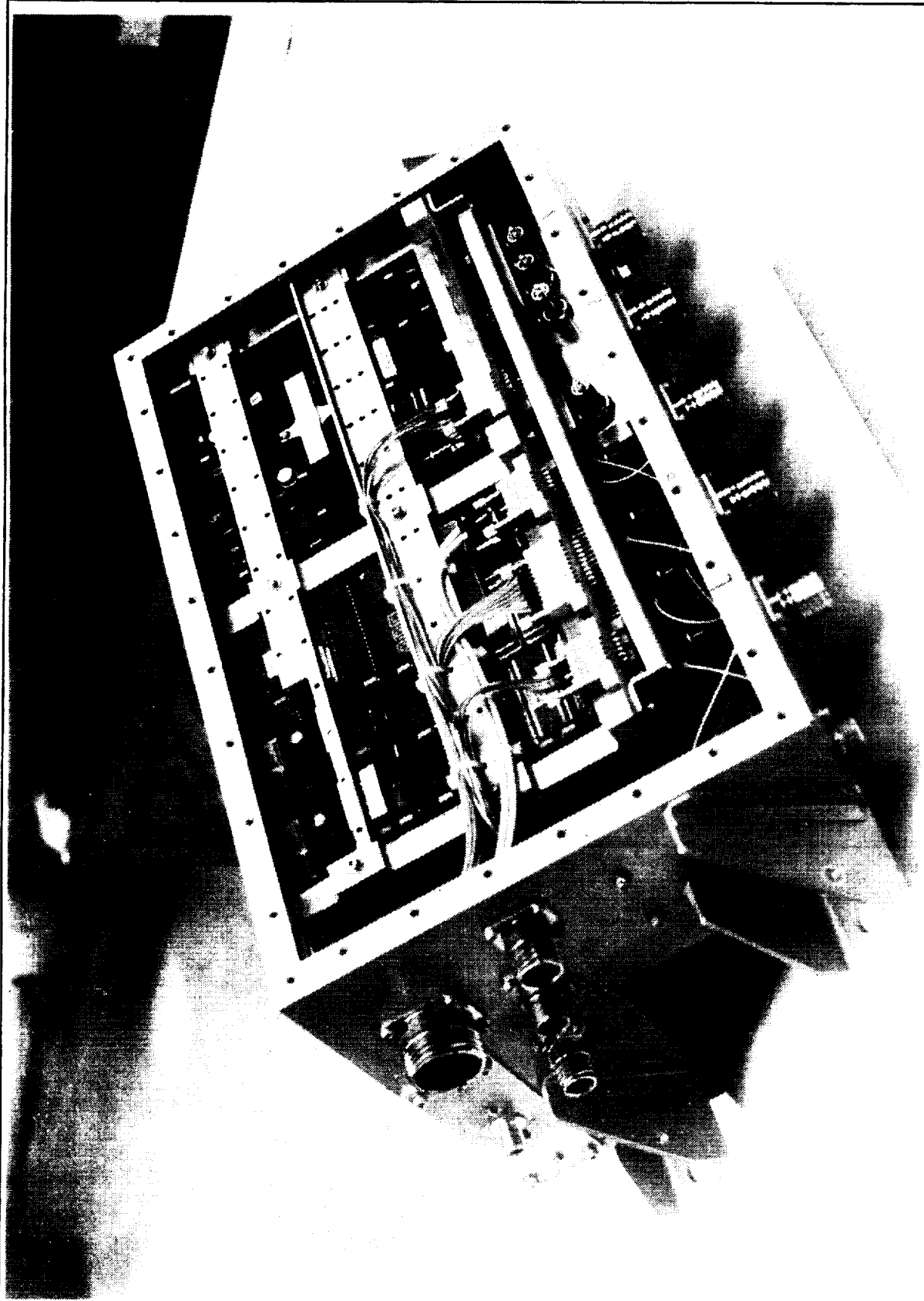

Figure 60 - EOU Assembly With Bottom Cover Removed

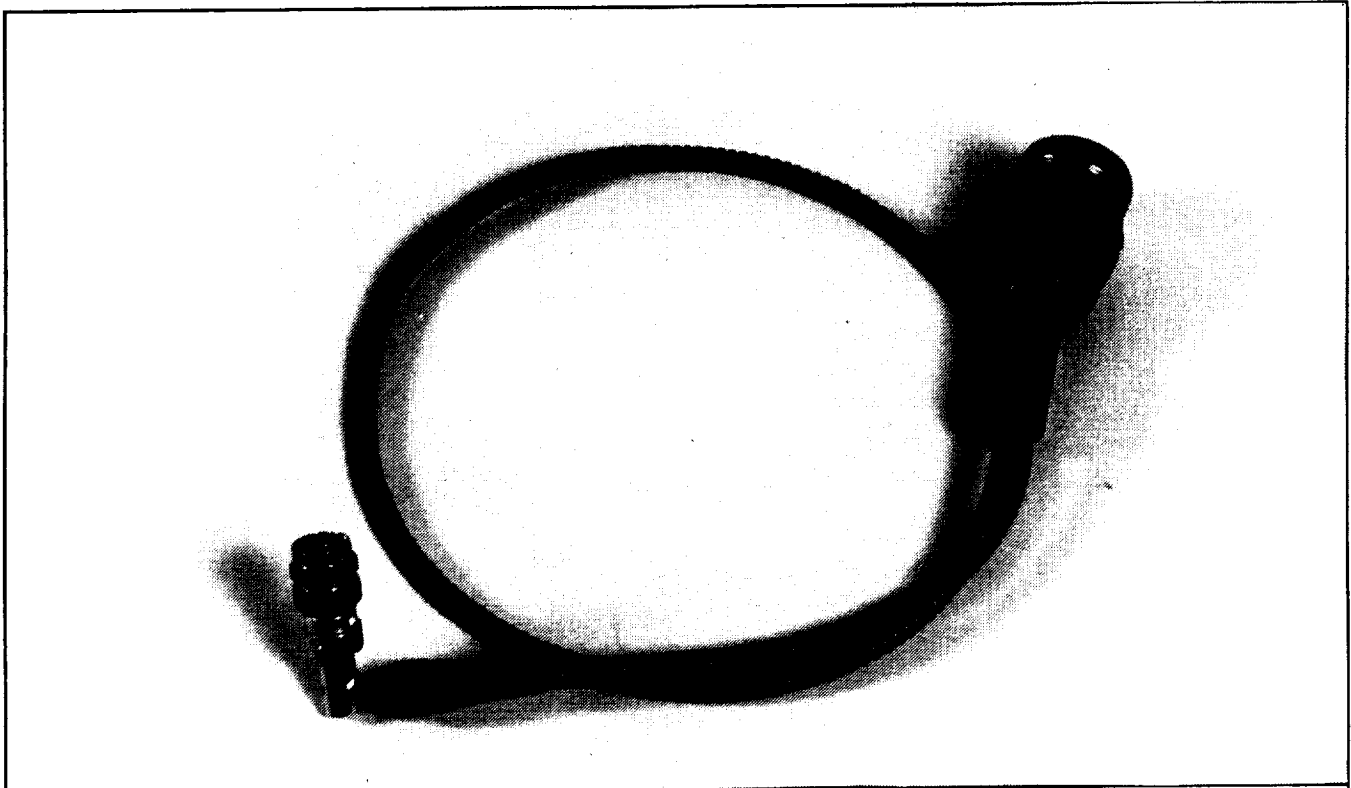

Figure 61 - EOU-J88 To ECU-J61 Electrical Cable

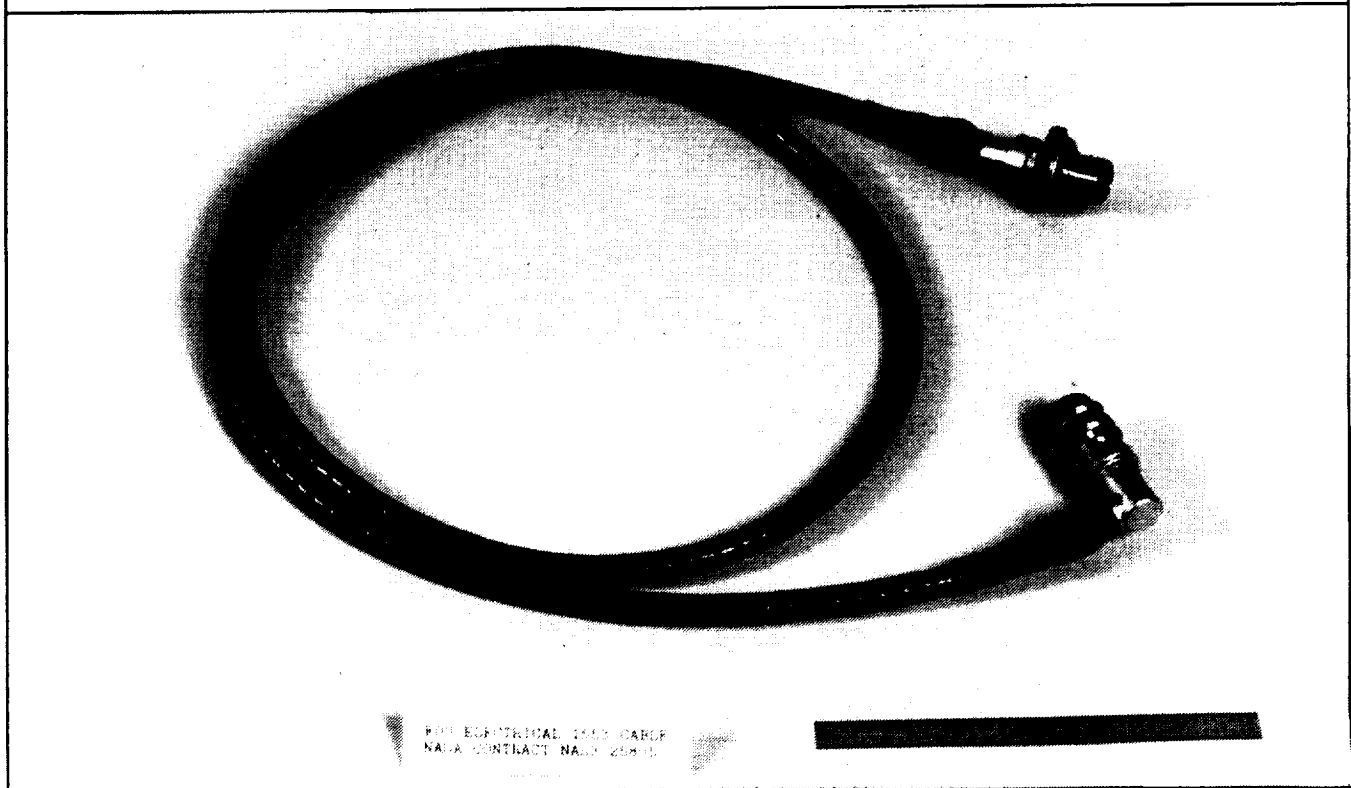

Figure 62 - EOU-J89 Cable For Transmission of MIL-C-1553 Data

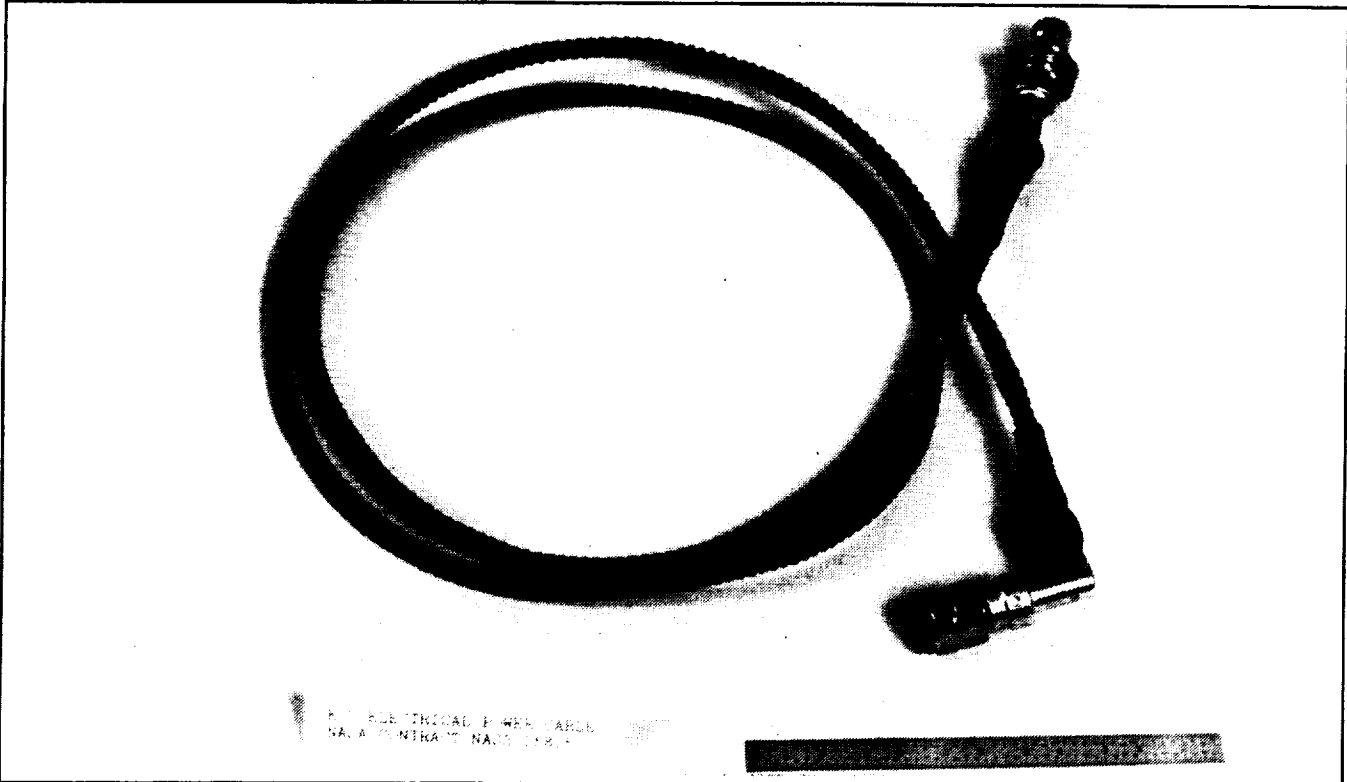

Figure 63 - EQU-J90 Cable For Supplying 28 VDC Power

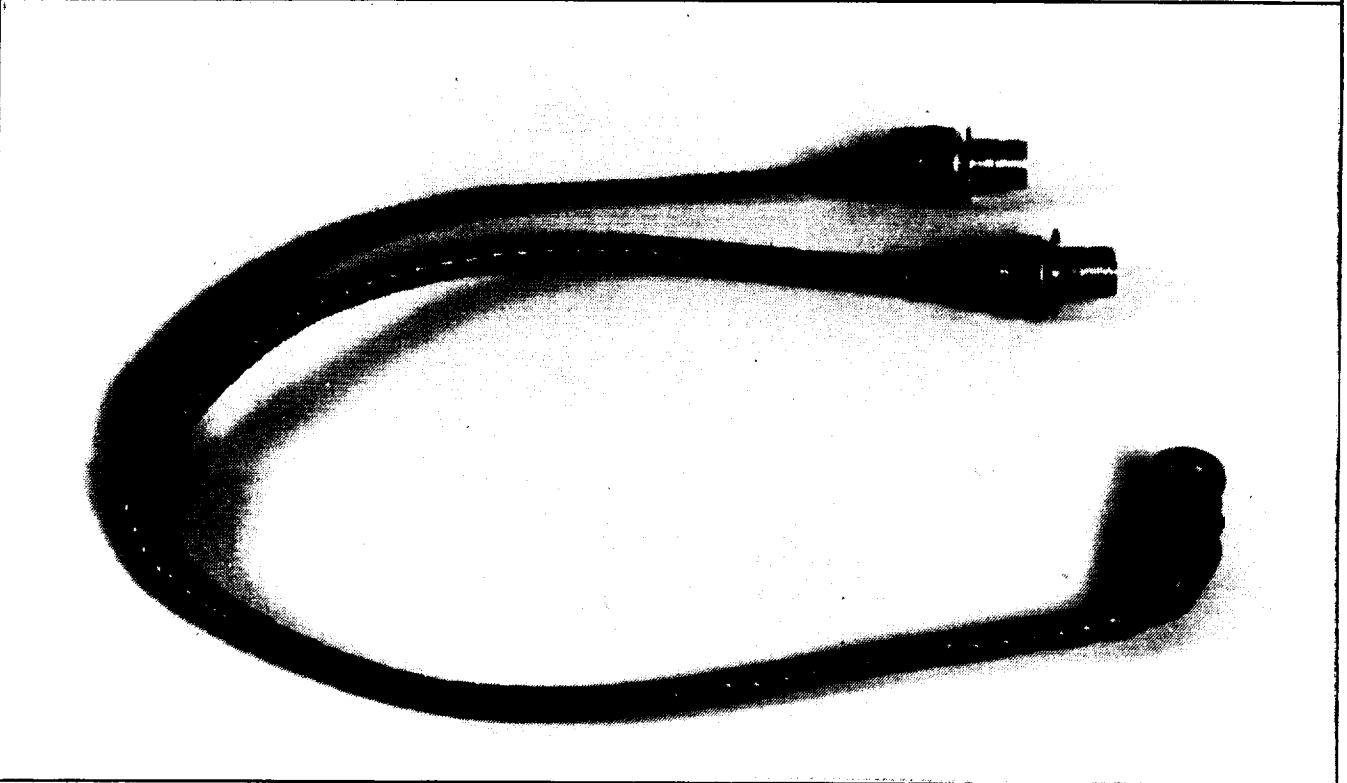

Figure 64 - NL Sensor Y Jumper Cable

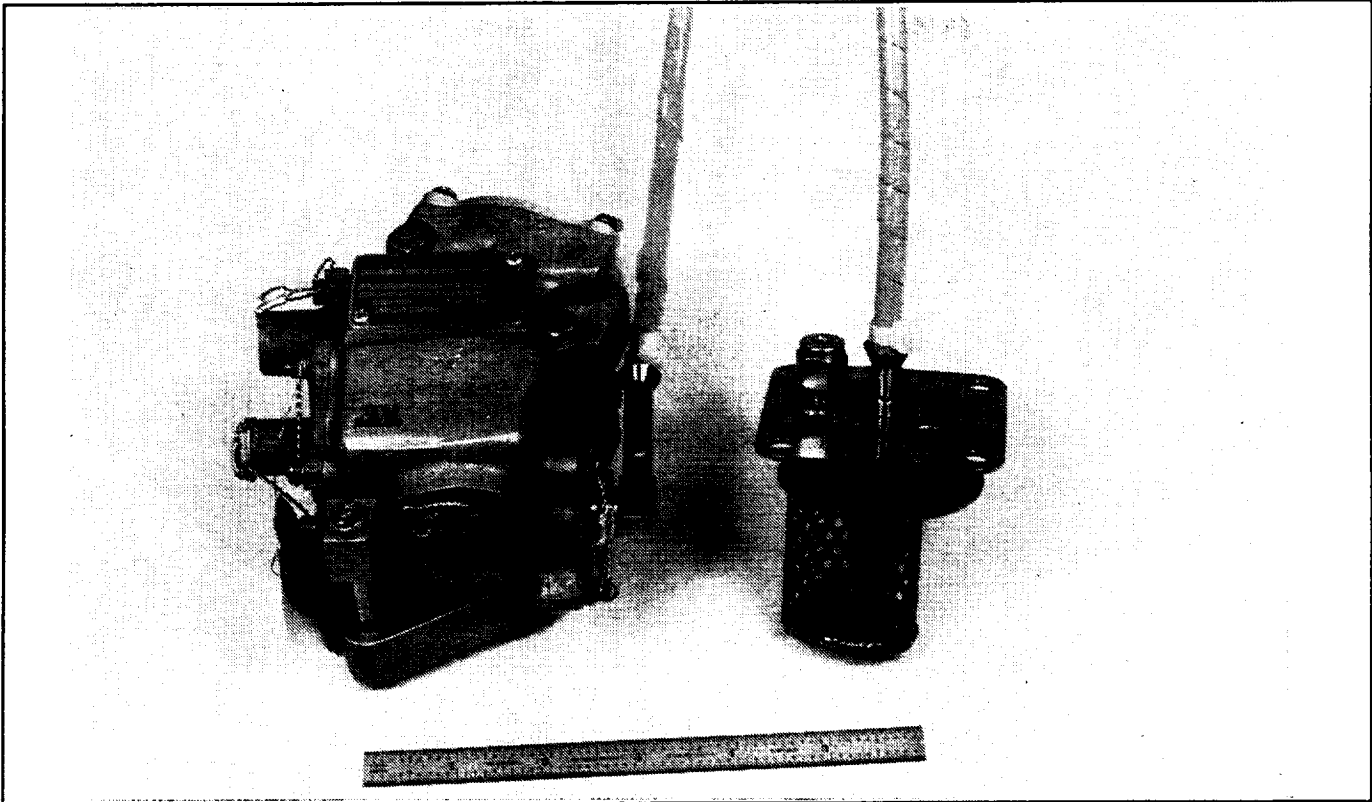

Figure 65 - Modified F404 CIT Transmitter For Fiber Optic T2.5 Probe Installation

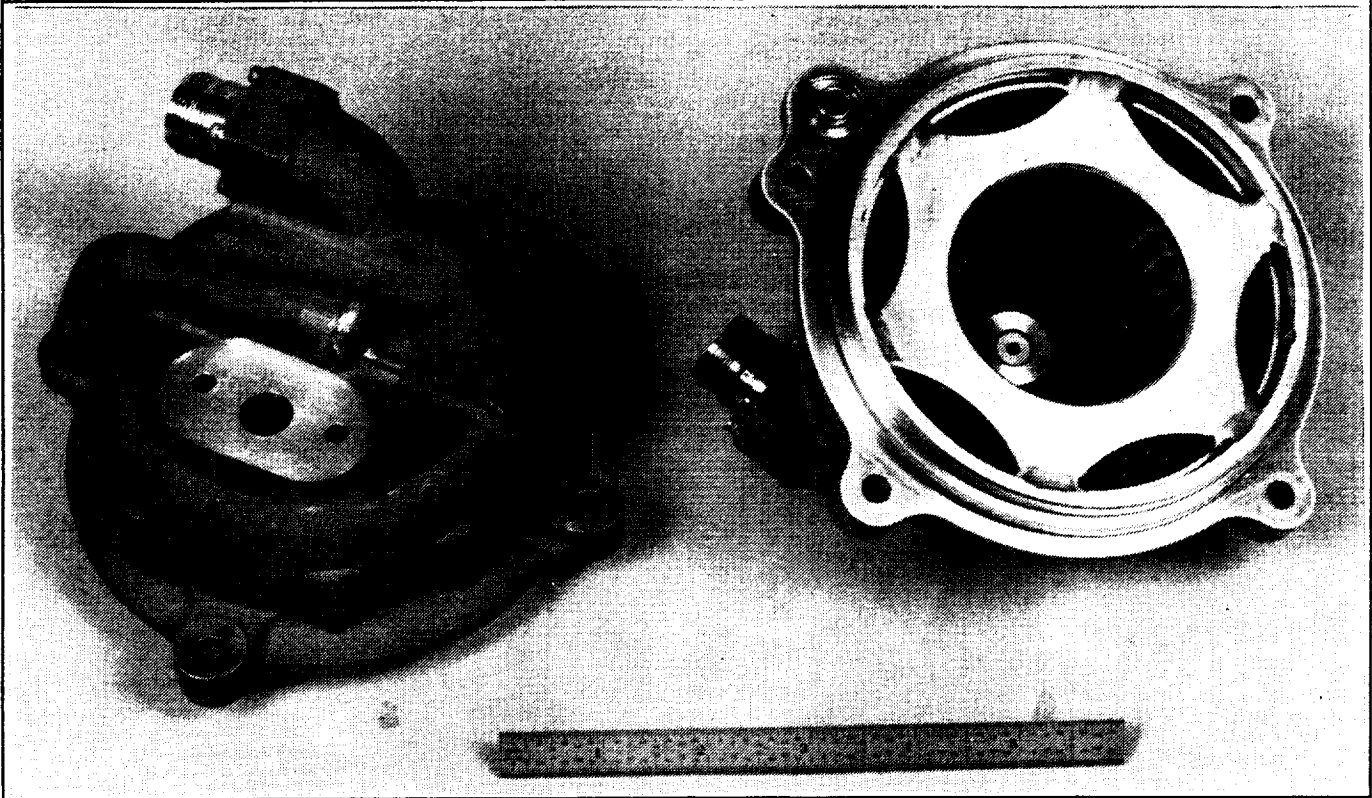

Figure 66 - Modified F404 Alternator Stator For Installation of Fiber Optic NH Sensor

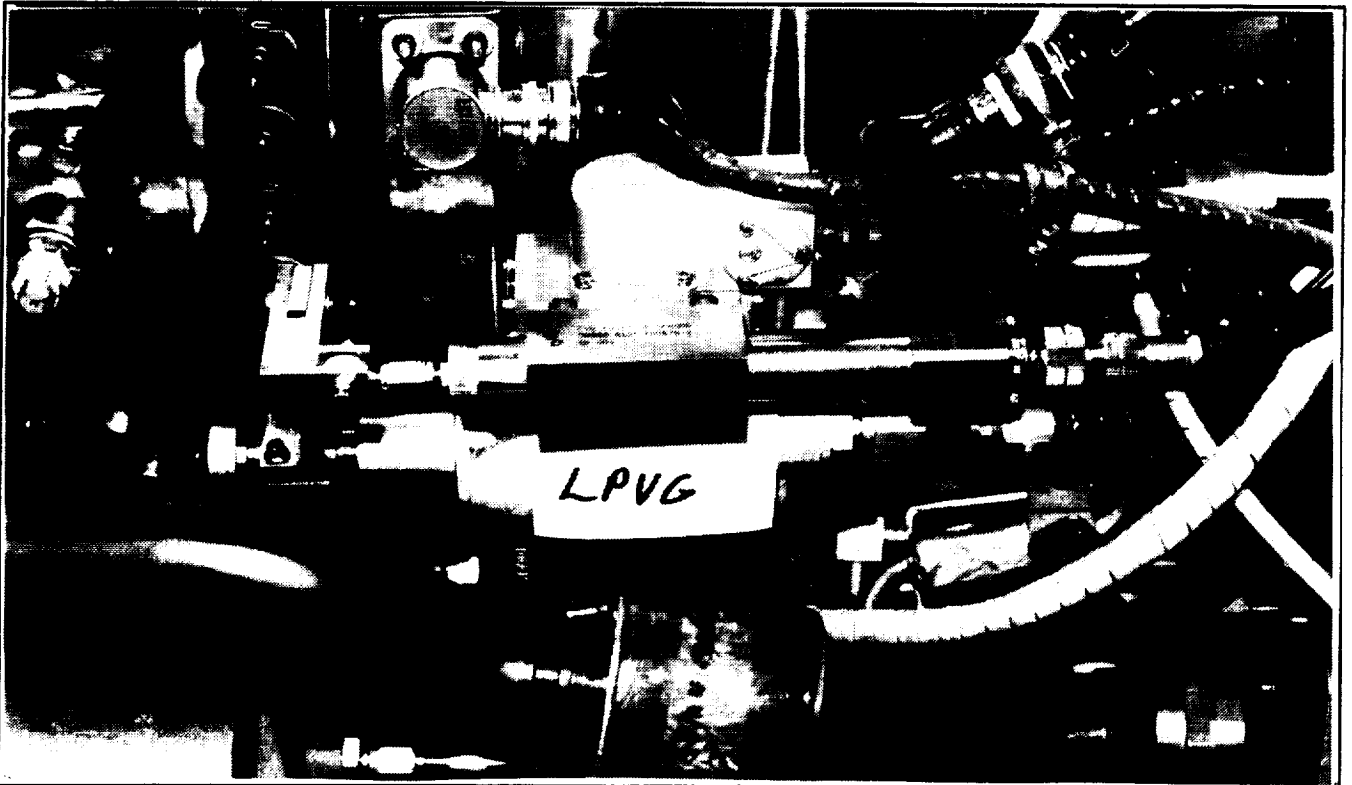

Figure 67 - Mounting of Fiber Optic FVG Position Sensor Onto F404 FVG Servovalve Block

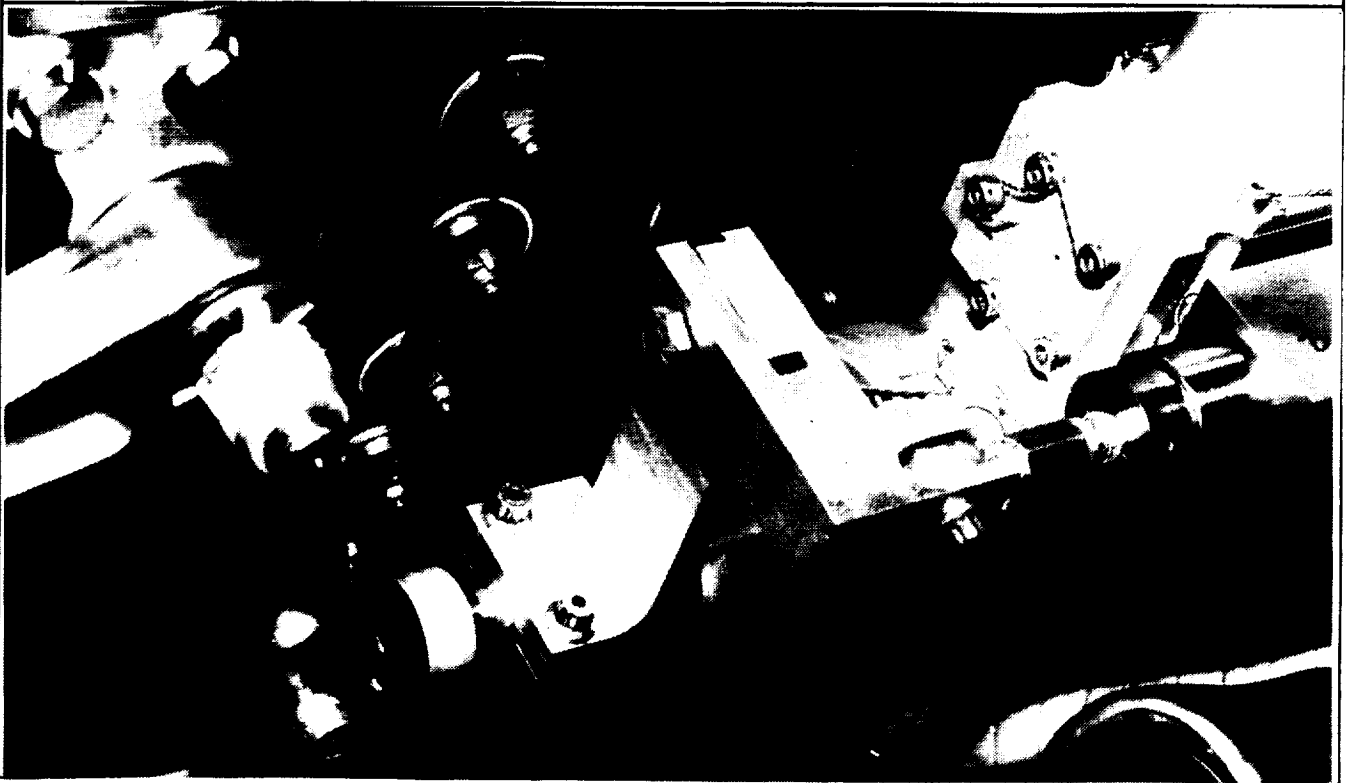

Figure 68 - Linkage Attaching Rod of Fiber Optic FVG Sensor To F404 FVG Acuator Piston

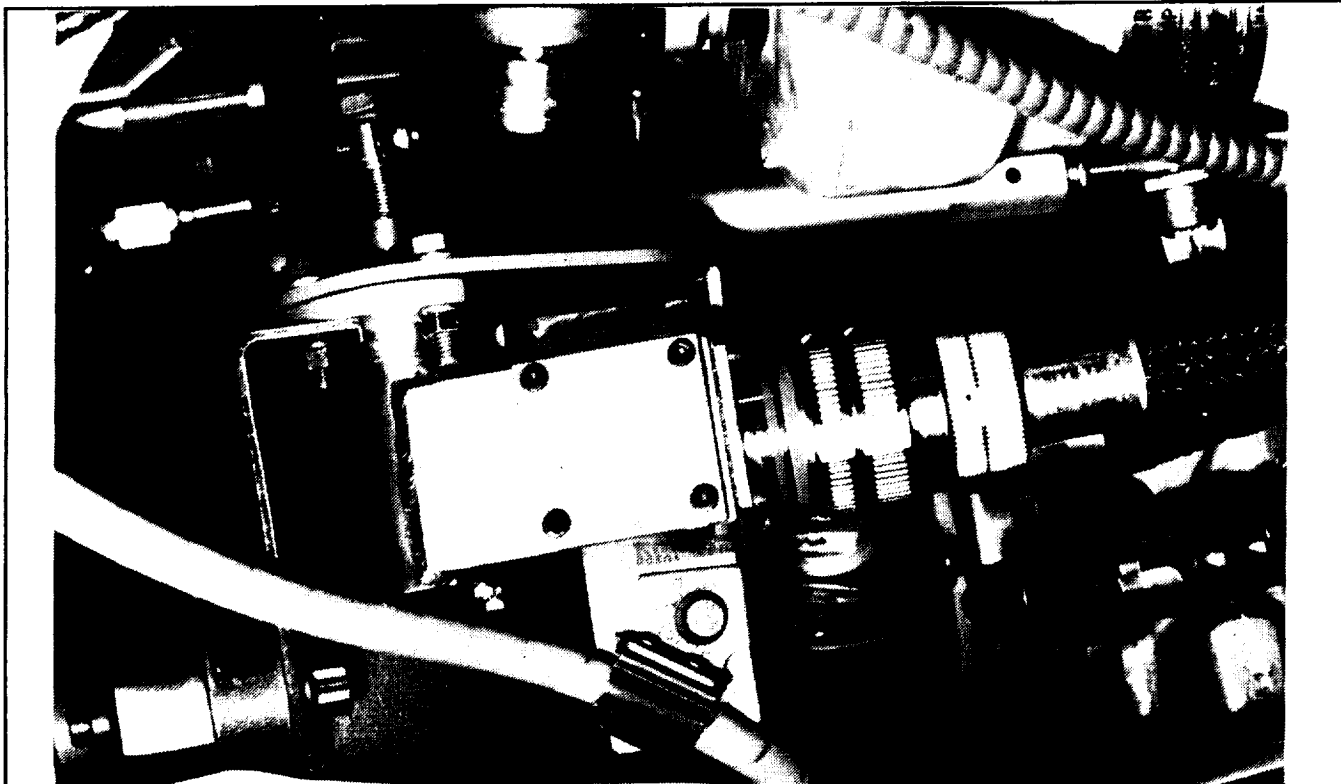

Figure 69 - Installation of Fiber Optic CVG Position Sensor At CVG Actuation Pivot Stud

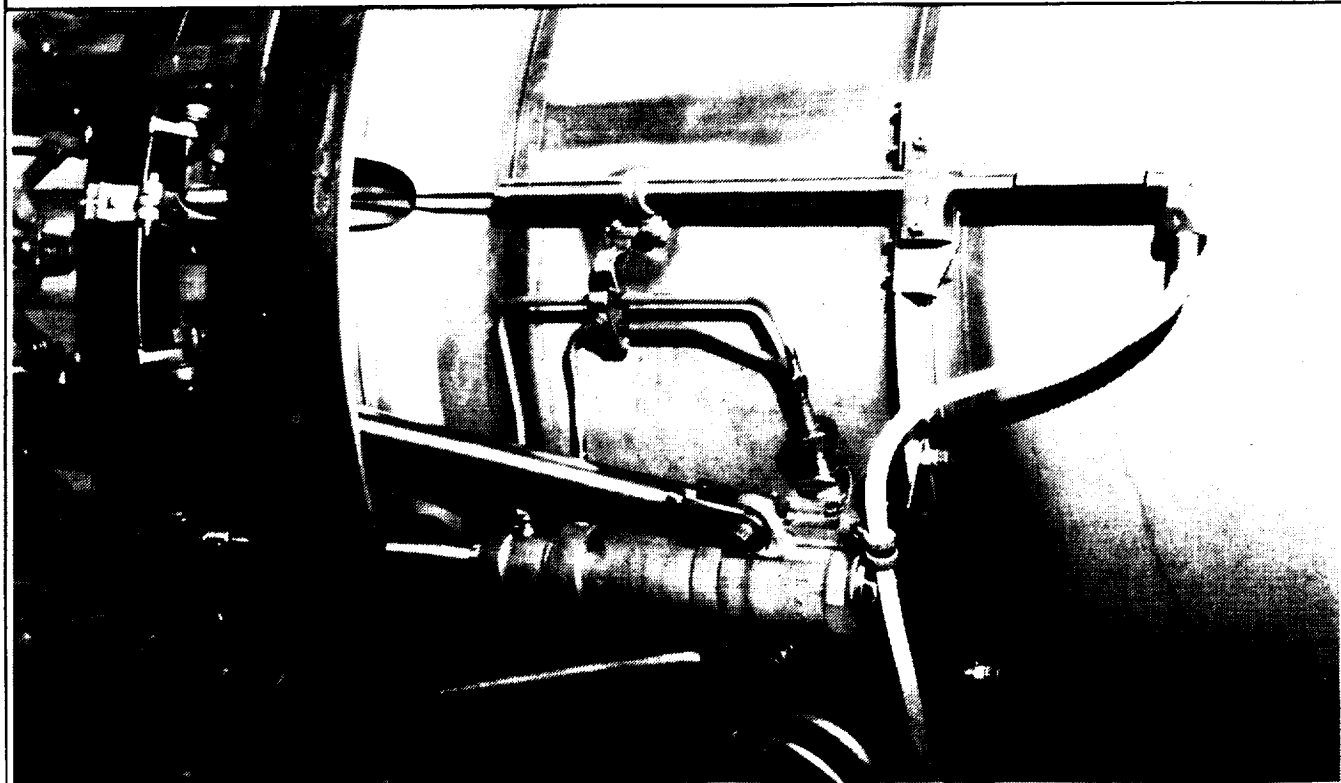

Figure 70 - Installation of VEN Fiber Optic Position Sensor On Engine AB Case



Figure 71 - Installation of Fiber Optic AB Flame Detector Spacer

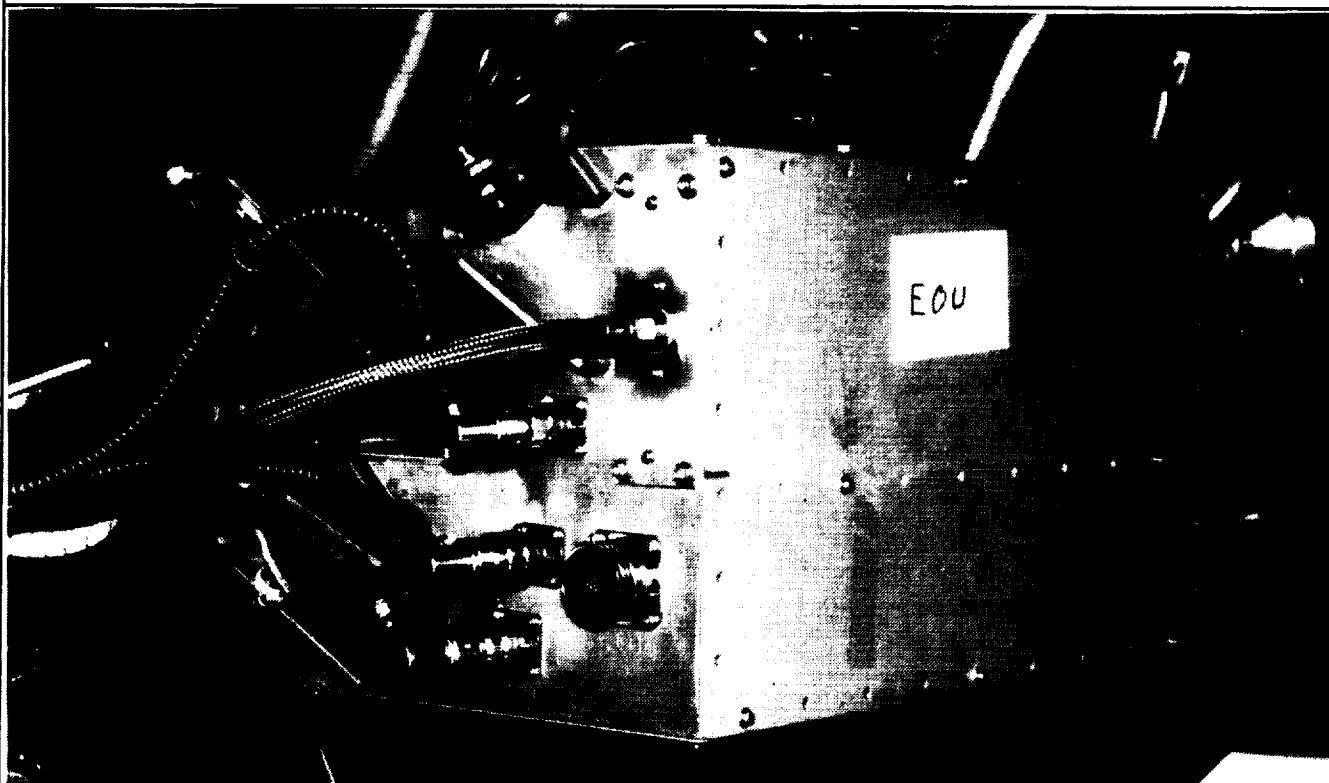

Figure 72 - Aft-Looking-Forward View of EOU Mounted On the F404 Engine

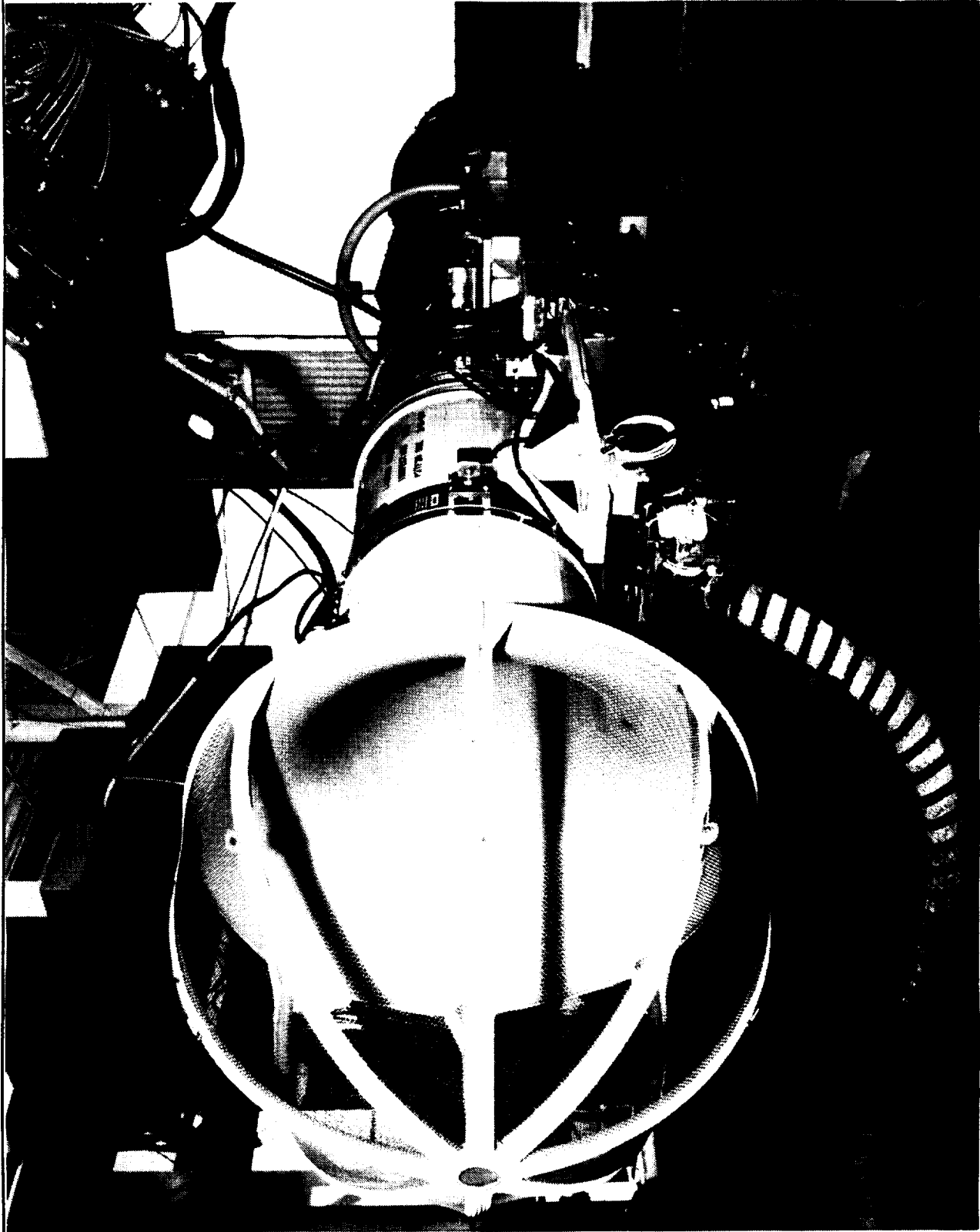

Figure 73 - Front View of FOCSI Engine At First Ground Test

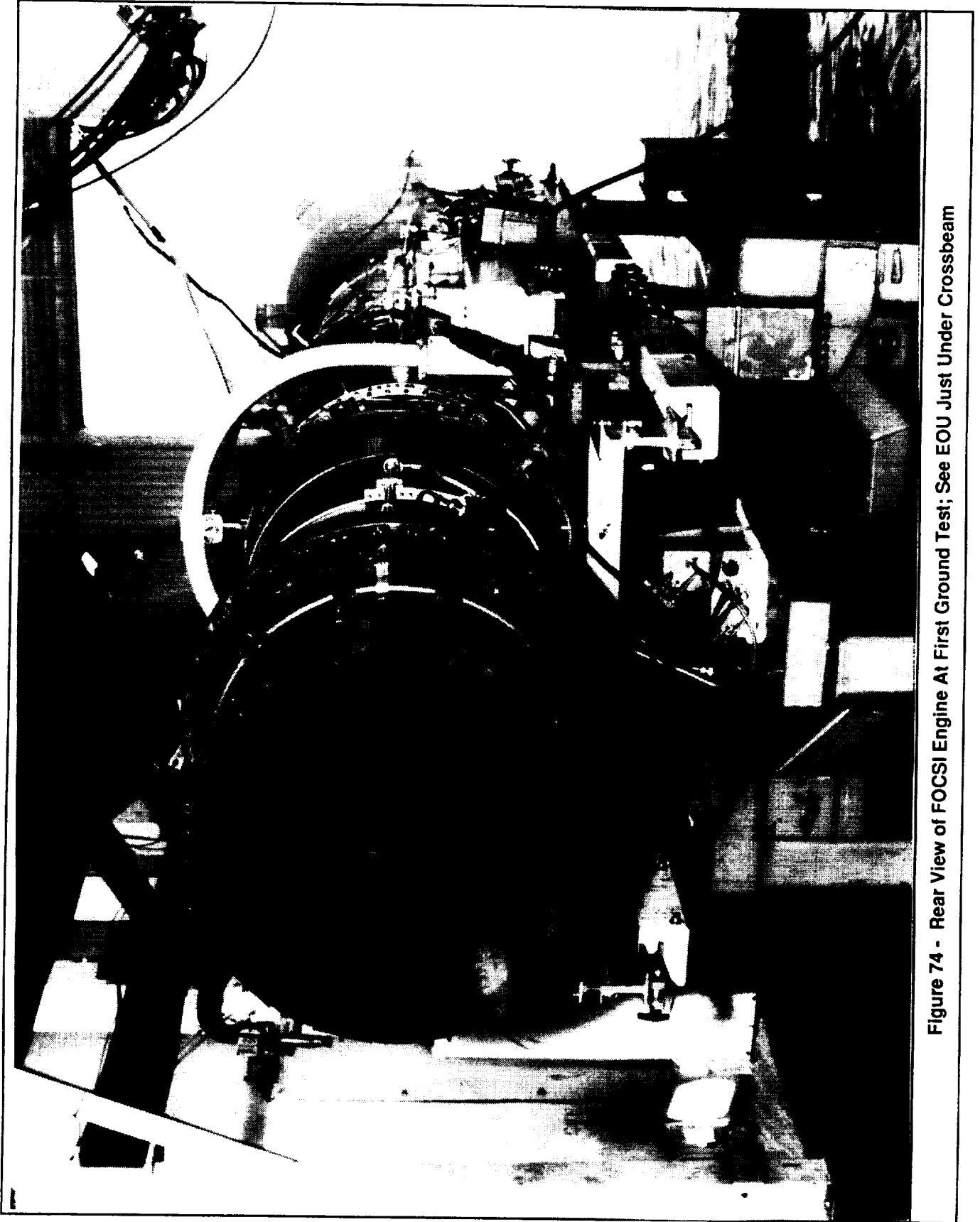

Figure 74 - Rear View of FOCSI Engine At First Ground Test; See EOU Just Under Crossbeam

APPENDIX-C

NL SPEED SENSING USING PRESSURE PULSES

1. THE SENSING TECHNIQUE

The F404-400 control system uses an electrical eddy current sensor to measure NL rotor speed. This sensor produces electrical pulses in response to the rotating titanium fan blade tips. The magneto-optic or Faraday effect type sensor is not useful in this application because titanium is a non-magnetic metal. One possible option was a photoelastic optical pressure sensing technique proposed by Aurora Optics, to sense and count the pressure pulses from the tips of the blades. Aurora's preferred configuration used 200 micron fiber with input/output ports physically 180° apart. The sensor was described by the Supplier as having very good environmental capabilities.

2. ENGINE PRESSURE SIGNATURE TEST

To help validate the pressure sensing speed concept, an experiment was conducted during a F404-400 engine run at GE Lynn in May, 1991, to measure and record the pressure fluctuations and levels at one of the two existing electrical NL sensor mounting locations on the engine fan frame. Kulite pressure sensors were used. Peak to peak pressure levels ranged from 1.6 to 12 psi over the speed range. Fourier Transforms of the pressure data at five engine operating points showed the one/blade frequency as the major frequency in each case, with other acoustic

signals mixed with it.

3. SIGNAL PROCESSING

Using the pressure signals recorded during the engine test, the present zero-crossing type signal processing for speed signals would not result in an accurate speed measurement. However, Aurora Optics attributed the acoustic signals other than one/blade to resonances resulting from the geometry of the sensor cavity configuration used for the test. They were confident that the acoustic signals were suppressible by locating the sensor diaphragm close to flush with the fan case inner wall.

4. RESULTS

At their preliminary funding level, Aurora could not fabricate a prototype sensor designed to acoustically filter out all but the one/blade pressure pulse. However, a breadboard sensor was provided which was adaptable to mount on the engine fan frame. About that same time the Banks Engineering electro-optic modulator technique was also being evaluated, and only one technique could be pursued. There was not time to conduct another engine test. With the information available, the decision was made to use the electro-optic modulator.

APPENDIX-D

ABBREVIATIONS

AB	Afterburner
CIT	Compressor Inlet Temperature
CVG	Compressor Variable Geometry
ECU	Engine Control Unit
EOA	Electro-Optic Architecture
EOU	Electro-Optic Unit
FVG	Fan Variable Geometry
LVDT	Linear Variable Differential Transformer
MFC	Main Fuel Control
MFP	Main Fuel Pump
NA	Numerical Aperture
NH	High Pressure Rotor Speed
NL	Low Pressure Rotor Speed
RTD	Resistive Thermal Device
TRD	Time Rate of Decay
T1	Engine Inlet Air Temperature
T2.5	Compressor Inlet Air Temperature
T5	Turbine Exhaust Gas Temperature
UV	Ultraviolet
VEN	Variable Exhaust Nozzle
WDM	Wavelength Division Multiplexing

REFERENCES

- (1) Poppel, G.L., Glasheen, W.M., Russell, J.C., "Fiber Optic Control System Integration", NASA CR-179568, 1987.
- (2) Poppel, G.L., Glasheen, W.M., "Electro-Optic Architecture for Servicing Sensors and Actuators in Advanced Aircraft Propulsion Systems", NASA CR-182268, 1989.
- (3) Phillips, R.W., "Final Report For Rosemount Model 701J1", Rosemount Report D9230172, Rev. A, Rosemount Inc., Aerospace Division, Eagan, MN, 10/9/92.
- (4) Gunderson, L.C., Final Report, Puget Sound Sensor, Inc., Woodinville, WA., GE PO 200-14-14E05166, 11/20/92.
- (5) Tregay, G.W., Calabrese, P.R., Finney, M.J., "T5 Fiber Optic Sensor For Advanced Aircraft Propulsion", GE PO 200-14-14Y08037, Final Report (draft), G. Tregay, P. Calabrese, and M. Finney, Draft, Conax Buffalo, Buffalo, NY, 2/15/94.
- (6) Final Report, Fiber Optic Sensor Hardware Development Program, CVG and VEN Sensors, GE PO's 200-14-14Y97679 and 200-18-14Y08036, 10/26/90 to 12/23/92, BEI, Motion Systems Co., Carlsbad, CA.
- (7) Banks, F.J., US Patent Number 4,950,884, Electro-Optic Modulator and Modulation Method, 8/21/90.
- (8) Hazel, B.D., GE FOCSI NH Core Optic Speed Sensor Final Report, Report No. ENCD-862-22126, GE PO 200-14-14Y97683, Allied-Signal Aerospace Co., 7/30/92.
- (9) Kozikowski, C., Kingma, D., Final Report FO4690-1, Electro-Optic Unit (EOU), GE Contract 200-14-14Y97687, Reporting Period 1/91-5/94, Litton Poly-Scientific, 5/25/94.

REPORT DOCUMENTATION PAGE

Form Approved
OMB No. 0704-0188

Public reporting burden for this collection of information is estimated to average 1 hour per response, including the time for reviewing instructions, searching existing data sources, gathering and maintaining the data needed, and completing and reviewing the collection of information. Send comments regarding this burden estimate or any other aspect of this collection of information, including suggestions for reducing this burden, to Washington Headquarters Services, Directorate for Information Operations and Reports, 1215 Jefferson Davis Highway, Suite 1204, Arlington, VA 22202-4302, and to the Office of Management and Budget, Paperwork Reduction Project (0704-0188), Washington, DC 20503.

1. AGENCY USE ONLY (Leave blank)		2. REPORT DATE July 1994	3. REPORT TYPE AND DATES COVERED Final - January 1990 to June 1994	
4. TITLE AND SUBTITLE Fiber Optic (Flight Quality) Sensors For Advanced Aircraft Propulsion			5. FUNDING NUMBERS 505-62-50 Contract No. NAS3-25805	
6. AUTHOR(S) Gary L. Poppel				
7. PERFORMING ORGANIZATION NAME(S) AND ADDRESS(ES) General Electrical Aircraft Engines 1 Neumann Way Cincinnati, Ohio 45215			8. PERFORMING ORGANIZATION REPORT NUMBER R94AEB175	
9. SPONSORING/MONITORING AGENCY NAME(S) AND ADDRESS(ES) National Aeronautics and Space Administration Lewis Research Center Cleveland, Ohio 44135-3191			10. SPONSORING/MONITORING AGENCY REPORT NUMBER NASA CR-191195	
11. SUPPLEMENTARY NOTES NASA Project Manager: Robert J. Baumbick				
12a. DISTRIBUTION/AVAILABILITY STATEMENT Unclassified - Unlimited Subject Category 00 or Categories 00 and 00			12b. DISTRIBUTION CODE	
13. ABSTRACT (Maximum 200 words) Development of flight prototype, fiber-optic sensing system components for measuring nine (9) sensed parameters (three temperatures, two speeds, three positions, and one flame) on an F404-400 aircraft engine is described. Details of each sensor's design, functionality, and environmental testing, and the electro-optics architecture for sensor signal conditioning are presented. Eight (8) different optical sensing techniques were utilized. Design, assembly, and environmental testing of an engine-mounted, electro-optics chassis unit (EOU), providing MIL-C-1553 data output, are related. Interconnection cables and connectors between the EOU and the sensors are identified. Results of sensor/cable/circuitry integrated testing, and installation and ground testing of the sensor system on an engine in October 1993 and April 1994 are given, including comparisons with the engine control system's electrical sensors. Lessons learned about the design, fabrication, testing, and integration of the sensor system components are included.				
14. SUBJECT TERMS fiber optic sensors electro-optic circuitry fiber optic propulsion control system			15. NUMBER OF PAGES 82	
			16. PRICE CODE	
17. SECURITY CLASSIFICATION OF REPORT Unclassified	18. SECURITY CLASSIFICATION OF THIS PAGE Unclassified	19. SECURITY CLASSIFICATION OF ABSTRACT Unclassified	20. LIMITATION OF ABSTRACT Unclassified	