

N95-70866

Characteristics of a Trapped-Vortex (TV) Combustor

K.-Y. Hsu, L. P. Goss and D. D. Trump
Systems Research Laboratories, Inc.
Dayton OH 45440-3696

W. M. Roquemore
Wright Laboratory
Wright-Patterson Air Force Base OH 45433-7103

ABSTRACT

The characteristics of a Trapped-Vortex (TV) combustor are presented. A vortex is trapped in the cavity established between two disks mounted in tandem. Fuel and air are injected directly into the cavity in such a way as to increase the vortex strength. Some air from the annular flow is also entrained into the recirculation zone of the vortex. Lean blow-out limits of the combustor are determined for a wide range of annular air flow rates. These data indicate that the lean blow-out limits are considerably lower for the TV combustor than for flames stabilized using swirl or bluff-bodies. The pressure loss through the annular duct is also low, being less than 2% for the flow conditions in this study. The instantaneous shape of the recirculation zone of the trapped vortex is measured using a two-color PIV technique. Temperature profiles obtained with CARS indicate a well mixed recirculation zone and demonstrate the impact of primary air injection on the local equivalence ratio.

INTRODUCTION

All practical combustors and commercial burners use recirculating flows to stabilize the flame. Recirculation zones provide regions of low velocity fluid where burning can take place. The recirculation zones also provide mixing of fuel, air, and hot products and a continuous ignition source that sustains the flame by transporting the hot mixture back toward the incoming reactants. Swirl, bluff-bodies, and rearward facing steps or a combination of these are commonly used to create recirculation zones. Swirl is used in most practical combustors and burners; however, the operating range of swirling flames is often not so large as desired. This is due to aerodynamic instabilities of the recirculation zone. Bluff-bodies and rearward facing steps are also used to create recirculation zones that promote flame holding in much the same way as swirl-stabilized flames. However, recirculation zones behind bluff-bodies and rearward facing steps are even less stable and have longer flame lengths than those established using swirl. Also, recirculation zones established by bluff-bodies or rearward facing steps do not entrain a large quantity of free stream fluid. This limits their application to high speed, premixed combustion systems such as those encountered in ramjets and gas turbine engine afterburners.

One technique for creating a stable recalculation zone is to trap a vortex between two disks mounted in tandem. This technique has been investigated as a means of reducing drag of bluff-bodies; however, it has never been considered as a means of stabilizing a flame^{1,2,3}. The objective of this paper is to evaluate the TV concept for flame stabilization. A vortex is trapped in a cavity and fuel and air are injected directly into the cavity in such a way that the vortex strength is increased. This provides a stable environment that can sustain the flame over a wide range of operating conditions.

EXPERIMENTAL

The combustor used in this study consists of a forebody and an afterbody disk as shown in Fig. 1 (a). The forebody, with diameter (d_f) of 70 mm, is located at the exit plane of the annular air duct which has a diameter of 80 mm. The blockage ratio defined as the area ratio between the forebody and the annular air duct is 76%. An annular air velocity of 50 m/s can be achieved in the facility. The annular and primary air flows originate from two air supplies and are controlled and metered separately. Fuel and primary air are delivered through concentric tubes into separate chambers in the afterbody which is 50.8 mm in diameter.

A schematic of the primary fuel and air injection plane is shown in Fig. 1 (b). Gaseous propane fuel is injected through 8 orifices (1.75 mm in diameter) and the primary air is supplied through 24 orifices (2.29 mm diameter) surrounding the fuel jets. The fuel and primary air jets are located so as to reinforce the vortex created in the cavity. Direct injection of primary air serves the following purposes : (1) provides direct control of local equivalence ratio inside the recirculation zone; (2) enhances mixing by increasing the mixing region through distributed fuel and air jets; and (3) provides cooling for the injector assembly. The separation between the forebody and the face of injector plane, H , can also be varied to optimize the condition for trapping a vortex and providing stable combustion. The pressure drop due to the annular air flow is measured by using a water manometer. The lean-blow-out limits of the combustor are established for a range of flow conditions. The effects of separation between forebody and afterbody and primary air on the combustor performance are also examined.

The velocity fields are obtained for both cold and reacting flow conditions. The instantaneous velocity field is obtained by employing the two-color Particle-Imaging Velocimetry (PIV)^{4,5} technique. A pulsed Nd:YAG laser and a YAG-pumped dye laser are used to generate two different wavelengths to eliminate the ambiguity in flow direction. Cylindrical lenses are used to form a laser sheet vertically across the centerline of the burner. The spherical particles (5 μm in diameter) are seeded through primary air jets. A 35 mm camera mounted at a right angle to the laser sheet is used to take images of particles using laser illumination. A synchronization circuit is used to control the time separation between the two laser pulses. The typical time separation between two lasers is about 30 μs for the flow conditions studied. A color scanner is used to digitize the images which are stored in the computer for further analysis. The theory and experimental setup of the PIV technique are presented in Ref. 4 and 5.

The radial temperature profiles at locations inside the recirculation zone are measured by using Coherent Anti-Stokes Raman Spectroscopy (CARS). The CARS system used in this study consists of a Nd:YAG-pumped broad-band dye laser for N_2 excitation. A CCD camera interfaced with the computer is used for single-shot broad-band detection. At each location, 1000 samples were collected at a rate of 10 Hz, and the spectra are stored for data analysis. Computer software was developed to obtain temperature information by curve-fitting the band-shape of the measured N_2 spectrum.

RESULTS AND DISCUSSION

An image of a flame stabilized in the TV combustor is shown in Fig. 2 (a). The flame is stabilized within the cavity between the afterbody and the forebody. Its bright blue color indicates low soot production. The overall equivalence ratio is about 0.06 which is considerably below the lean blow-out limit of typical swirl stabilized flames. The annular air velocity is 33 m/s. The primary equivalence ratio calculated using the fuel and primary air is about 1.2. The flame is attached in the shear layer near the forebody. This is typical for all TV stabilized flames when a small amount of primary air (5% of annular air) is injected into the recirculation zone. The

instantaneous velocity field is shown in Fig. 2 (b) for the flow domain drawn in Fig. 2 (a). The center of the recirculation zone is evident in Fig. 2 (b) and corresponds to the dark region in the flame image. The plane of the velocity field also includes part of a fuel and primary air jet as is evident from the large velocities near the afterbody face. In general, increasing the fuel flow rate with the air flow rates fixed results in longer flame with a yellow sooting region near the vortex center. Increasing the primary air flow reduces the flame length and eliminates the soot formation. However, the general structure of the flame inside the cavity is essentially the same as that shown in Figs. 2 (a) and 2 (b) for a wide range of conditions.

The pressure drop across the TV combustor is measured for both cold and reacting flows. A 150 mm long 80 mm diameter Pyrex tube was used to confine the flow. The measured pressure drop does not include that across the fuel and primary air jets. The percentage of pressure drop (dp/P) as a function of H/d_f (ratio of separation H and the diameter of the forebody d_f) for cold flow conditions is shown in Fig. 3. The differential pressure between annular air and ambient is denoted by dp , and P is the ambient pressure. The pressure drop (dp/P) across the TV combustor increases as the velocity of the annular air is increased. A minimum pressure drop occurs at $H/d_f = 0.6$ for three different annular air flow rates. This is in good agreement with the forebody and afterbody separation found for maximum drag reduction using the TV concept^{1,2,3}.

The criteria for trapping a vortex are given in Ref. 1 where the afterbody diameter was found to be $0.75d_f$ and the separation of the forebody and afterbody was $0.55d_f$. Combusting flow experiments were conducted to determine the optimum diameter of the afterbody and the separation. It was found that the condition for trapping a vortex in cold flows is near optimum for providing a visibly stable flame. This is not evident in Fig. 4 where the pressure drop as a function of H/d_f , for different conditions of primary air, in both cold and reacting cases is shown. The pressure drop is higher in combusting flows than that in the cold experiments due to heat release. Also, the pressure drop increases with the primary air flow rate for both cold and reacting flows although it is more notable for the combusting cases. The heat release appears to modify the flow pattern in such a way as to increase the effective blockage ratio and this resulted in a higher pressure drop. This is evident in the combusting case since the flame increases in diameter as the primary air flow is increased.

The effect of primary equivalence ratio on pressure drop for different H/d_f is shown in Fig. 5. The primary air flow rate determines the local equivalence ratio and thus the heat release rate in the recirculation zone. The pressure drop is expected to be a maximum at the condition of maximum heat release rate. This occurs for a primary equivalence ratio of unity for various H/d_f and is consistent with the data in Fig. 5. The local equivalence ratio in the recirculation zone may be slightly leaner than the primary equivalence ratio due to entrained air from the annular flow. The entrainment rate may also vary with flow conditions. However, the data in Fig. 5 suggest that very little air is entrained into the recirculation zone when there is primary air flow.

The lean blow-out limits for the TV combustor are illustrated in Figs 6 and 7. With zero primary air flow rate, the overall equivalence ratio at lean blow-out increases with the annular air velocity and with increasing H/d_f , as shown in Fig. 6. The slope of the lean blow-out versus H/d_f curve changes at H/d_f around 0.65. This could indicate that air entrainment might increase with large separation distance (H/d_f). The overall equivalence ratio at lean blow-out is less than 0.035 which illustrates the excellent stability of this combustor. The effect of primary air equivalence ratio on the overall lean blow-out limit is shown in Fig. 7 for an $H/d_f = 0.55$. These data suggest that for a fixed annular air flow rate there is a near linear relationship between the overall and primary equivalence ratio. Furthermore, for a fixed primary equivalence ratio the overall equivalence ratio at blow-out will be lower for higher annular air flow rates. It is also noted that the slopes of the curves for high and low annular air flow rates are nearly the same. It is evident

that by controlling the primary equivalence ratio, one can optimize conditions for minimum lean blow-out for different annular air flow rates.

Direct-injection of primary air and fuel into the recirculation zone of the trapped vortex has a major impact on flame stability and local equivalence ratio. This is illustrated by the temperature profiles in Figs. 8, 9, and 10 for $H/d_f = 0.59$ at three different axial locations ($z = 5, 25$ and 39 mm) as measured from the forebody face. The overall equivalence ratio is about 0.2 with an annular air velocity of 50 m/s and 25 slpm of fuel. Data are presented for primary air flow conditions of 56 and 280 slpm, which correspond to primary equivalence ratios of 11.1 and 2.2, respectively. In the figures, the mean temperature profiles are marked with open symbols. Closed symbols denote the fluctuations in temperature. Near the forebody as shown in Fig. 8, the temperature is relatively flat across the forebody with temperature fluctuations of about 200 K. The radial temperature profiles at an axial location near the center of vortex are relatively flat in the range of $r > 20$ mm, as shown in Fig. 9. The jet-dominant region can be clearly seen at $r = 18$ mm where fluctuation in temperature is higher than that at other locations. It is also noted that the flame increases in diameter as the primary air is increased. The primary air has a significant impact on the temperature profiles near the afterbody plane as noted in Fig. 10. The temperature in the flat region ($r > 20$ mm) increases by about 700 K as the primary air is increased. The maximum temperature of 2200 K equivalent to stoichiometric flame temperature has been measured for high primary flow conditions, however, the fluctuation in temperature is only about 200 K. The fluctuations in temperature are lower under the leaner condition ($\Phi_{\text{primary}} = 2.2$) than under the rich condition ($\Phi_{\text{primary}} = 11.1$). In general, the temperature is higher as the primary equivalence ratio approaches the stoichiometric condition, however, lower temperature are observed in the range of $r < 20$ mm where the primary air jets were dominant. The temperature is higher in the downstream location near the injector plane, where additional entrainment of air is expected. The flat temperature profiles indicate that the recirculation zone of the trapped vortex behaves like a well stirred reactor for most conditions. However, the temperature fluctuations are relatively large especially for the low primary air flow rate (high primary equivalence ratio). This suggest that the mixing may not be complete in the recirculation zone.

SUMMARY

The TV combustor demonstrates extremely low lean blowout and pressure drop for a wide range of flow conditions. The primary air has significant impact on the combustion characteristics, namely, stability, local stoichiometry and lean blow-out. The direct control of the primary air can maintain stable combustion over a very wide range of operating conditions that has not been achieved by other combustors. Additional data on combustion efficiency and emissions will be presented at the meeting.

REFERENCES

1. Mair, W. A., "The Effect of a Rear-Mounted Disc on the Drag of a Blunt-Based Body of Revolution", *The Aeronautical Quarterly*, pp. 350-360, Nov 1965.
2. Little, Jr., B. H., Whipkey, R. R., "Locked Vortex Afterbodies, *J. of Aircraft*, Vol, 16, No. 5, pp. 296-302, May 1979.
3. Gharib, M. and Roshko, A., "The Effect of Flow Oscillations on Cavity Drag", *J. Fluid Mech.*, Vol. 177, pp. 501-530, 1987.
4. Goss, L. P., Post M. E., Trump, D. D. and Sarka, B., "Two Color Particle Imaging Velocimetry", *J. Laser Appl.*, p.p. 36-42, 1991.
5. Post, M. E. and Goss, L. P., "Two-Color Particle-Imaging Velocimetry in Vortex Structures", 31st Aerospace Sciences Meeting & Exhibit, AIAA-93-0412, 1993.

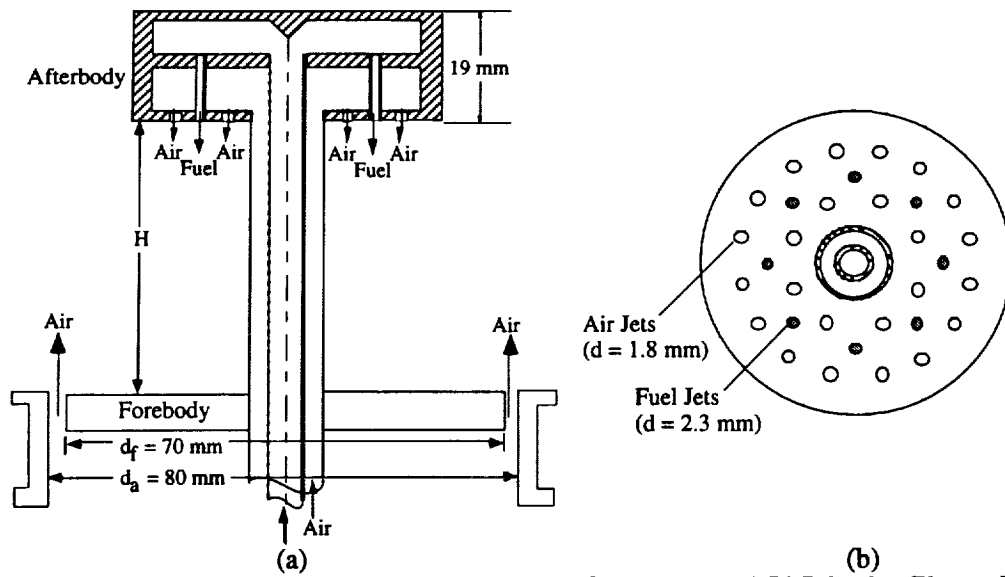

Figure 1. Schematic Diagrams of (a) Trapped-Vortex Combustor and (b) Injection Plane of Afterbody

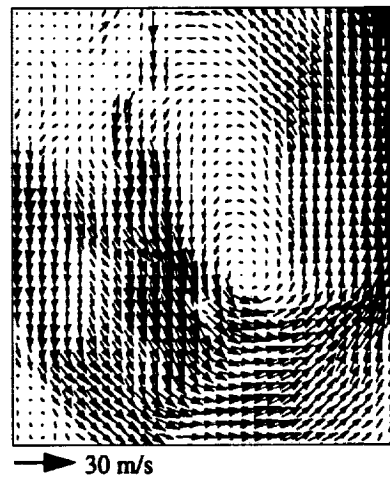
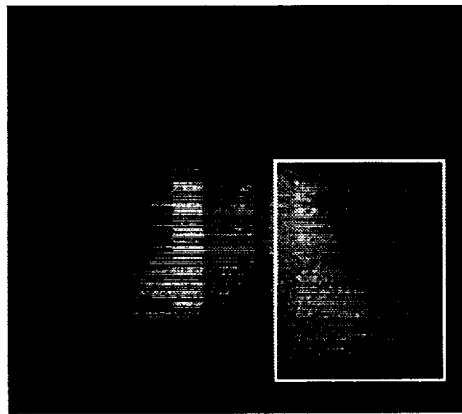

Figure 2. (a) Flame Image and (b) Instantaneous Velocity Field

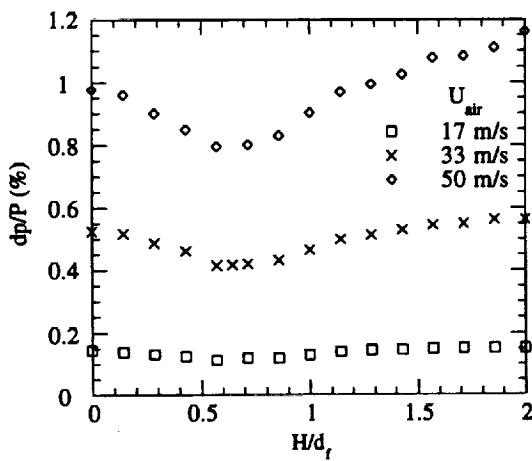

Figure 3. Pressure Drop versus H/d_f (Cold Flow without Primary Air)

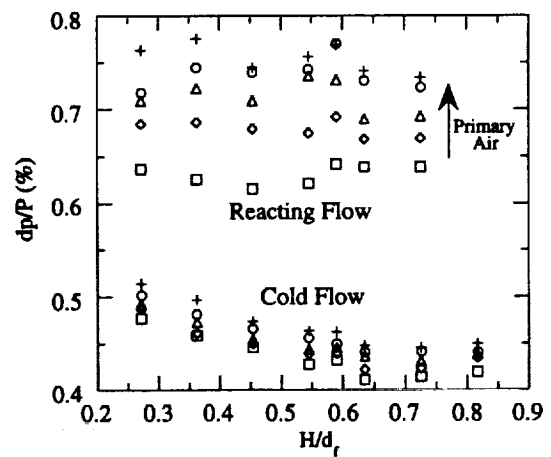

Figure 4. Comparison of Pressure Drop between Cold and Reacting Flows ($\Phi_{Overall} = 0.12$) at $U_{air} = 33$ m/s

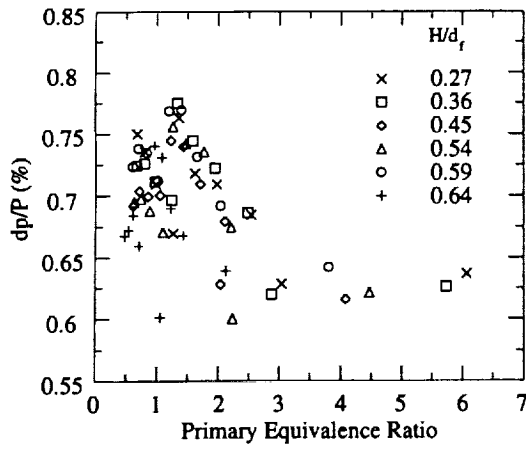

Figure 5. Pressure Drop versus Primary Equivalence Ratio at $U_{air} = 33$ m/s

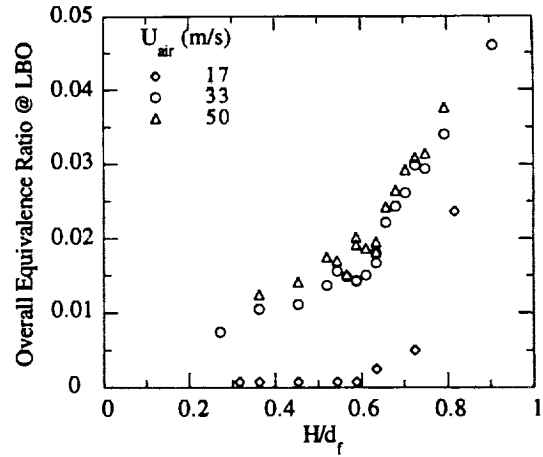

Figure 6. Effect of H/d_f on Lean Blow-out under Various Annular Air Flow Conditions

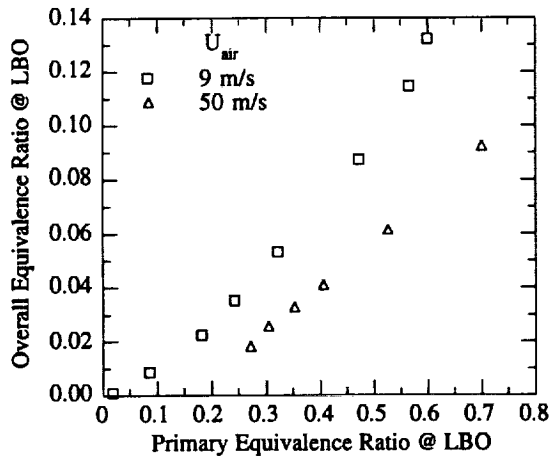

Figure 7. Relationship between Overall and Primary Equivalence Ratios at LBO ($H/d_f = 0.55$)

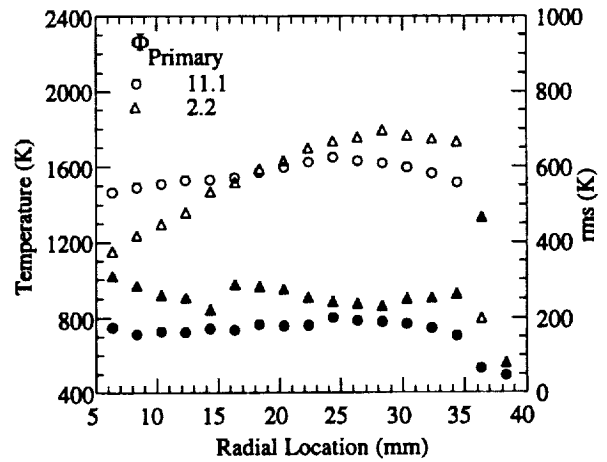

Figure 8. Temperature Profiles at $z = 5$ mm ($H/d_f = 0.59$)

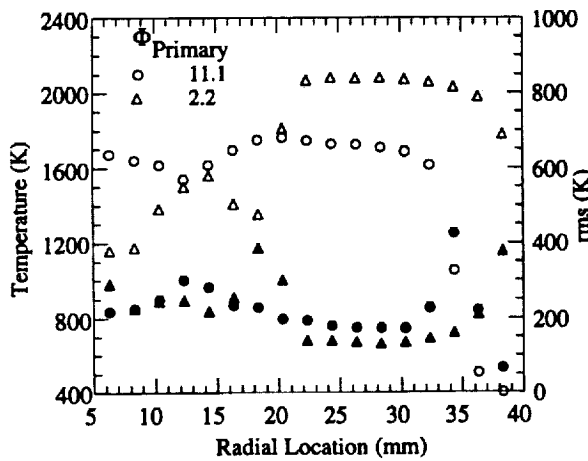

Figure 9. Temperature Profiles at $z = 25$ mm ($H/d_f = 0.59$)

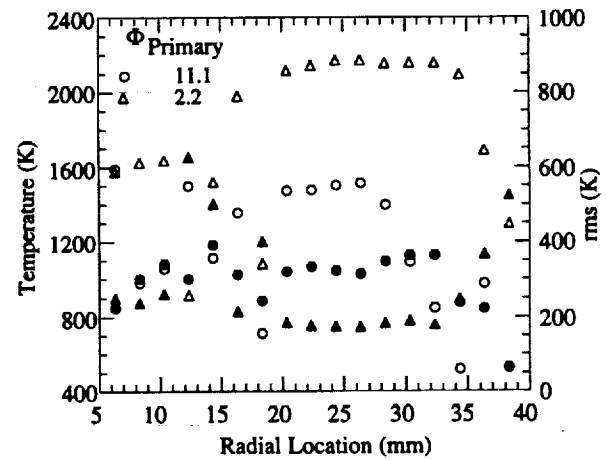

Figure 10. Temperature Profiles at $z = 39$ mm ($H/d_f = 0.59$)