

1N-09  
22325  
34 P

NASA Technical Memorandum 109083

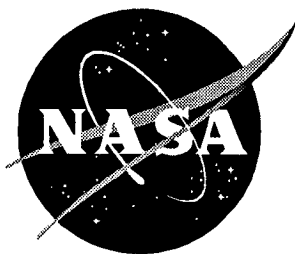

# Effects of Vibration on Inertial Wind-Tunnel Model Attitude Measurement Devices

Clarence P. Young, Jr.  
*North Carolina State University, Raleigh, North Carolina*

Ralph D. Buehrle  
*Langley Research Center, Hampton, Virginia*

S. Balakrishna and W. Allen Kilgore  
*Vigyan, Inc., Hampton, Virginia*

(NASA-TM-109083) EFFECTS OF  
VIBRATION ON INERTIAL WIND-TUNNEL  
MODEL ATTITUDE MEASUREMENT DEVICES  
(NASA. Langley Research Center)  
34 p

N95-11466

Unclas

G3/09 0022325

July 1994

National Aeronautics and  
Space Administration  
Langley Research Center  
Hampton, Virginia 23681-0001



## Table of Contents

	<u>Page</u>
Summary . . . . .	1
Introduction . . . . .	1
Symbols List . . . . .	2
Experimental Test Setup and Procedure . . . . .	2
Instrumentation . . . . .	2
Data Acquisition Systems . . . . .	3
Test Procedure . . . . .	4
Physics of Problem . . . . .	4
Discussion of Test Results . . . . .	5
First Order Correction Model . . . . .	6
Correction to AOA Signal in Presence of Model Dynamics . . . . .	8
Model Vibration Effects on Drag Measurement . . . . .	10
Concluding Remarks . . . . .	10
References . . . . .	11
Appendix A - Derivation of Equations for Accelerations Induced at the AOA Inertial Device Due to Model Dynamics . . . . .	12

## List of Tables and Figures

- Table 1. Measured Natural Vibration Mode Parameters for Transport Model/Sting Configuration.
- Figure 1. Schematic of test set-up for exciting model system in pitch and yaw planes.
- Figure 2. Instrumentation for model AOA dynamic tests.
- Figure 3. NTF model protection and shutdown system (MPSS).
- Figure 4. AOA bias error due to model vibration induced centrifugal acceleration.
- Figure 5. Yaw plane views of 10 and 14 Hz natural vibration modes for transport model.
- Figure 6. Pitch plane views of 11 and 16 Hz natural vibration modes for transport model.
- Figure 7. AOA response versus yawing moment for 10 and 14 Hz yaw vibration modes.
- Figure 8. MPSS display illustrating AOA static and dynamic response with yaw moment (due to 14 Hz excitation) as a function of time.
- Figure 9. AOA response versus pitching moment for 11 and 16 Hz pitch vibration modes.
- Figure 10. Response of two AOA sensors located equidistance fore and aft of center of rotation for the 14 Hz yaw mode.
- Figure 11. Measured and estimated AOA error comparisons for 16.25 Hz model/balance pitch mode versus pitching moment.
- Figure 12. Measured and estimated AOA error comparisons for 14.2 Hz model/balance yaw mode versus yawing moment.
- Figure 13. Measured and estimated AOA error comparisons for 10 Hz yaw mode versus yawing moment.
- Figure 14. Measured and estimated AOA error comparisons for 11 Hz pitch mode versus pitching moment.
- Figure 15. First order correction for AOA signal in presence of model dynamics.
- Figure 16. Schematic for making on-line corrections to AOA device output.

## SUMMARY

Results of an experimental study of a wind tunnel model inertial angle of attack sensor response to a simulated dynamic environment are presented. The inertial device cannot distinguish between the gravity vector and the centrifugal accelerations associated with wind tunnel model vibration which results in a model attitude measurement bias error. Significant bias error in model attitude measurement was found for the model system tested. The model attitude bias error was found to be vibration mode and amplitude dependent. A first order correction model was developed and used for estimating attitude measurement bias error due to dynamic motion. A method for correcting the output of the model attitude inertial sensor in the presence of model dynamics during on-line wind tunnel operation is proposed.

## INTRODUCTION

Measurement of model attitude or angle of attack (AOA) in modern wind tunnels is based on the use of high accuracy servo accelerometers (see ref. 1). The tunnel flow is calibrated with respect to the local gravity vector, while the model attitude sensor measures the gravity component due to model attitude which is proportional to the angle of attack. For quasi-static conditions, this technique provides a highly accurate measurement of model attitude based on the local gravity vector. However, oscillatory motion(s) of the model and its onboard AOA device (during wind tunnel tests) create centrifugal acceleration(s), which are sensed by the inertial device. The inertial sensor cannot separate the gravity induced acceleration from the centrifugal acceleration. Most wind tunnels use a cantilever arm (sting) to support the model. The model mounted at the end of the sting experiences dynamic oscillations due to unsteady flow and induces angle of attack errors in inertial attitude sensors. Further, the centrifugal acceleration also induces a drag force equal to the product of the mass of model and the forward or longitudinal acceleration. The particular device(s) used to measure wind tunnel model attitude at the NASA Langley Research Center (LaRC) are described in reference 1. The problem of the inertial device sensitivity to model vibrations is also discussed in reference 1.

The National Transonic Facility (see ref. 2) is located at NASA Langley Research Center and has the capability for testing models at full scale Reynolds number and dynamic pressure up to 7000 psf. Severe model vibrations have been encountered on a number of models at high dynamic pressures since the tunnel began operation. References 3 through 6 document studies of model and model support vibrations in the facility. Although it was known that model vibrations were affecting the accuracy of model attitude measurements while testing, the bias error in AOA measurement has never been quantified for a model system from a structural dynamics point of view. In the summer of 1993 an experiment was conducted at the NTF to study the onboard angle-of-attack sensor response to a simulated dynamic environment using a transport model system as a test bed. This study was conducted at the NTF, however, the AOA sensitivity problem is not unique to this facility or to the LaRC. The problem exists anytime model attitude is being measured by this type of inertial device in the presence of significant model system vibrations.

The objectives of this paper are: (1) to describe an experimental study that was conducted to examine the effects of model system vibrations on the AOA device and (2) to propose a mathematical model for estimating first order AOA bias error due to complex model vibrations. Results of the study are presented, along with the derivation of a first order correction algorithm, and approach to correcting AOA output during wind tunnel operation.

## SYMBOLS LIST

A/D	analog to digital
AOA	angle of attack
$a_x$	axial acceleration
$a_z$	acceleration in $z$ (normal) direction
$A_i$	peak acceleration for the $i^{th}$ mode
$A_z$	peak acceleration in $z$ (normal) direction
DAS	data acquisition system
$f_i$	frequency for $i^{th}$ mode
$F_{axial}$	axial force
FFT	Fast Fourier Transform
$g$	gravitational constant
Hz	Hertz
in.	inches
lb	pounds
MPSS	Model Protection and Shutdown System
$M_m$	mass of model
$r$	radius arm
$r_i$	rotational radius arm of $i^{th}$ mode
$W_m$	weight of model
$V_z$	velocity in normal direction
$\alpha$	angle of attack
$\Omega$	angular velocity
$\omega$	circular frequency

## EXPERIMENTAL TEST SETUP AND PROCEDURE

The test setup is shown schematically in figure 1. A transport model configuration was chosen as the test bed. The basic approach was to measure the filtered and unfiltered output of the AOA device in a simulated dynamic environment. Although it was known that an AOA bias error was associated with model vibrations (see ref. 1), actual bias errors had not been investigated nor quantified on a wind tunnel model test configuration.

### Instrumentation

Accelerometers were installed at various locations on the model and sting (see fig. 1) to measure dynamic response and natural mode characteristics. The mode shapes were acquired in order to

characterize the rotational motion of the onboard AOA device which is required to understand the problem physics and examine ways for correcting AOA bias error. An electrodynamic shaker was used to excite the model and model support structure using band limited random, sine and swept sine input. Two miniature accelerometers were installed on the face of the AOA package (located inside the model) to measure pitch and yaw accelerations. However, one of the devices (pitch plane) failed early in the test without producing useful data. A triax set of accelerometers located on the fuselage upper surface was subsequently used to obtain off-axis accelerations at the AOA location.

The model was instrumented with an AOA Q-flex accelerometer package (see ref. 1) maintained at a constant temperature of 165°F. The model system was installed in a model assembly bay at the NTF as shown in figure 1. The mounting consisted of a rigidly supported cantilever (sting), that is positioned by a pitch-roll-translation mechanism. The model was attached to the sting through a six component strain gage balance.

An electrodynamic shaker was used to excite the model through a single point force linkage. The model/model support sting were instrumented with accelerometers (see fig. 1), in order to determine the triaxial accelerations on the total system. The excitation was applied in the pitch and the yaw planes at the model fuselage hard points approximately 10 in. forward of the balance moment center.

The instrumentation system used in the test, (shown schematically in figure 2), consisted of the following: (1) A force gage and 11 accelerometers; (2) Hewlett Packard (HP) 3566A multi-channel signal analyzer; (3) Electrodynamic shaker and power amplifier; (4) Stand alone laser based optical model angle-of-attack detector; (5) Q-flex AOA device in the model with signal conditioner having two outputs of 0-300 Hz bandwidth and 0-0.25 Hz bandwidth (filtered); (6) Six component strain gage balance; and (7) The Model Protection and Shutdown System (MPSS) system (see fig. 3) capable of on-line data analysis, recording and display.

### **Data Acquisition Systems**

Dynamic and steady state data were acquired on the NTF Model Protection and Shutdown System (MPSS) currently under development. The MPSS cabinet and CRT monitor are shown in figure 3.

The MPSS, although designed primarily for model system protection against structural failure, is a high speed, on-line, dynamic data acquisition and analysis system. The MPSS is a 24 channel dynamic data acquisition system, with a sample rate of 4000 samples/sec per channel for 16 channels (dynamic data), with a frequency range of 1 to 256 Hertz (Hz), and 8 channels at 10 samples/sec (tunnel process data). The system architecture consists of a Precision 6000 signal conditioning and anti-aliasing filter system, Pentek Analog to Digital (A/D) and Digital Signal Processing (DSP) boards, 2.5 Gbytes of disk storage, and is controlled by a SPARC 2 workstation. Features include high speed Fast Fourier Transform (FFT) computation for 16 channels simultaneously in 10-20 milliseconds at 1 Hz resolution, and time domain graphics displays for up to six channels simultaneously. Wind tunnel interlock and trip algorithms are programmed to protect the model from dynamic overload and aeroelastic instability.

The filtered and unfiltered AOA signals along with the unfiltered six component balance signals were acquired, recorded and analyzed by the MPSS. The MPSS was used to establish the load levels,

(e.g., yawing moment and pitching moment) for which AOA output signals were acquired for each dynamic test condition. This test also provided an opportunity to demonstrate that the MPSS was buffered sufficiently to assure that no interference with the AOA signal could occur due to MPSS operation.

A Hewlett Packard Model 3566A multi-channel signal analyzer system was used to provide the drive signal to the shaker and to capture time and frequency domain data from the onboard accelerometers. The same system was used to obtain frequency response function data to define the natural mode characteristics, i.e., mode shapes and frequencies. Digital voltmeters were used to measure the dc signal (shift) from the onboard AOA during dynamic testing. The measured dc shift was compared to the MPSS output display. A laser system was also used as a baseline to measure model attitude.

### Test Procedure

The model system was locked at or near zero degree angle of attack under static conditions. Initially, the model and model/sting modes were identified using sine sweep and pseudo random excitation of the model in the yaw and pitch planes using the shaker and HP signal analyzer system. The single frequency forced response tests were conducted by controlling the shaker input to provide a defined peak to peak pitch or yaw moment on the model force balance. The test variables were yaw moment for vibration modes that had predominantly yaw motion, and pitch moment for vibration modes that had predominantly pitch motion. The yaw and pitch moments were monitored on the MPSS system. The AOA response data were tabulated as a function of balance pitch or yaw moment for each of the vibration modes excited.

### PHYSICS OF PROBLEM

The physics of the model motion is illustrated in figure 4. It is seen from the figure that the centrifugal acceleration due to model dynamics affects the sensor measurement with respect to the gravity vector. This is true for both pitch and yaw oscillations associated with different modes of vibration. The centrifugal acceleration term  $r\Omega^2$ , is the product of the distance of the AOA device accelerometer from the center of rotation,  $r$ , and the angular velocity squared,  $\Omega^2$ . The output of the AOA device is given symbolically in figure 4 along with the equation for the corrected angle of attack in terms of the  $r\Omega^2$  contributions. The correction equation is the summation of the contribution of each vibration mode (by superposition), i.e., the  $\sum_{i=1}^n r_i\Omega_i^2$  contribution. The equations characterizing the model vibration and resulting correction algorithm are derived in Appendix A.

The approach to developing the correction algorithm given in Appendix A requires measurement of the normal (pitch) and lateral (yaw) accelerations at the AOA device location or some other location near the AOA sensor. The correction algorithm developed in the appendix was used to predict the AOA bias error using data from the dynamic test. The results are discussed in the next section.



## DISCUSSION OF TEST RESULTS

The test results clearly show that AOA bias error can be significant and is due to centrifugal (axial) acceleration associated with model vibration. The AOA bias error amplitude is vibration amplitude and mode dependent, i.e., the contribution of each mode depends on the mode shape (effective radius arm to AOA device measured from center of rotation) and the total amplitude of motion at the AOA device location.

The vibration modes studied in this test are tabulated in table 1 and illustrated graphically in figures 5 and 6. The mode shapes are shown as "stick" models, i.e., fuselage, wings and empennage components are represented by lines. Initial testing focused on the 10 and 14 Hz modes in the yaw plane. The measured AOA bias error output as a function of yaw moment is shown in figure 7 for both the 10 and 14 Hz yaw vibration modes. The 14 Hz yaw mode was excited up to 12,000 in-lb. peak to peak which is approximately 100% of the balance full scale design load. Note that the variance of AOA bias error is quadratic in nature as can be seen from the mechanics of the motion (see Appendix A). Note that a measured AOA bias error of approximately  $-0.15$  degrees occurs at about 12,000 in-lb. (peak to peak). The results obtained for exciting the 10 Hz mode are also displayed in figure 7. The AOA bias error for this mode appears to be more sensitive to yaw moment as 2000 in-lb. (peak to peak) corresponds to a bias of  $-0.125$  degrees. Interestingly, for the 10 Hz mode, the rotation of the model occurs around a point located on the empennage, see figure 5.

The desired attitude measurement accuracy for aerodynamic testing is 0.01 degree. This level is exceeded at about 3000 in-lb. peak to peak for the 14 Hz mode which is a relatively low level of vibration, when compared with wind tunnel operational experience for large transport models. It should be noted that operation at 50% or greater of full scale yaw moment dynamic load (although not desirable) is not unusual for large transport models when testing at high dynamic pressures in the NTF.

A time trace of the AOA response (static and dynamic) for the 14 Hz mode sinusoidal vibration is given in figure 8. This figure is a snapshot of the MPSS display taken near the end of the variable force, constant frequency (14 Hz) forced response test of the 14 Hz model/balance yaw mode. Also shown on the figure is the balance yaw moment response and balance pitching moment response (which is extremely low since little cross-coupling is present). Note that for the yaw moment peak to peak amplitude of 12,000 in-lb., the AOA static output gives a value of  $-0.14$  degrees which is the mean value of the AOA dynamic signal (upper graph in the figure). Also from figure 8 it can be seen that as the yaw moment amplitude begins to decrease, asymptotically, the AOA static value begins to follow the moment decrease and approaches zero as the load (yaw moment) approaches zero. These results clearly demonstrate a situation where the model pitch plane attitude is held constant, but the AOA inertial sensor indicates a negative angle of attack due to the centrifugal acceleration associated with model vibration in the yaw plane.

The measured AOA bias error for the pitch plane modes of 11 and 16.25 Hz as a function of pitching moment is given in figure 9. The 16 Hz model/balance rotation mode was excited up to 15,000 in-lb. peak to peak which is about 60% of the full scale design value on the balance pitching moment component. Note that a bias error of approximately  $-0.5$  degrees is associated with this amplitude. These data show that the AOA bias error is highly sensitive for this mode, and the AOA accuracy criterion of .01 degree is exceeded at approximately 2,000 in-lb. peak to peak or

about 15% of the balance full scale design value. The 11 Hz sting bending mode was difficult to excite in the pitch plane due to the problem of the shaker having to react the weight of the model system. However, the 11 Hz mode was found not to be a significant contributor to the AOA bias error as indicated by the solid symbols in figure 9.

It was somewhat of a surprise to find that the AOA response was less sensitive to sting bending modes, (referred to as "sting whip" in ref. 1), when compared to the model/balance rigid model rotational modes. However, examination of the centrifugal acceleration term (eq. A-7 in Appendix A) reveals that the acceleration is inversely proportional to the rotation radius and the square of the frequency. Thus, the perception that sting whip is the major contributor to AOA bias because of the perceived large rotation radii (distance from center of rotation to the AOA device) does not hold true. Hence, model/balance modes with smaller radii can give larger errors than model/sting bending modes referred to as sting whip modes. The problem is complex in that the bias error is a function of both the mode shape and vibration amplitude. The number of vibration modes that contribute to the AOA bias error will be dependent on the model/sting configuration being tested.

As a result of these tests, a better understanding of the problem physics was gained along with the determination that AOA bias error can significantly exceed the advertised AOA device measurement accuracy in the presence of vibration amplitudes routinely encountered during testing in the NTF and other high speed facilities. This prompted a limited study (not in original test plan) to examine ways of correcting the AOA output to account for the centrifugal accelerations sensed by the AOA device under vibratory motion.

A simple experiment was conducted to show that one way to correct the AOA output for one vibration mode was to mount another Q-flex accelerometer the same distance aft of the point of rotation as the onboard AOA distance forward of the point of rotation. This setup gives two bias outputs of opposite sign, which when averaged gives the true model attitude or angle of attack reading. The test setup is shown in figure 10, along with the test results. This test demonstrated clearly that the AOA bias error is due to centrifugal forces.

### FIRST ORDER CORRECTION MODEL

Experimental test results show that the measured pitch and yaw accelerations obtained at or near the AOA package location on the model can be used to estimate the AOA bias error. For example, the equation for correcting the angle of attack due to vibration in the pitch plane is of the form:

$$\text{Angle of Attack} = \sin^{-1} [\text{AOA output} + \text{Error}] \quad (1)$$

which from figure 4 would take the form of

$$\text{Angle of Attack} = \sin^{-1} \left[ \frac{\text{AOA output} + \sum_{i=1}^n r_i \Omega_i^2}{g} \right] \quad (2)$$

where the AOA output is assumed to be in gravitational ( $g$ ) units,  $r$  is the distance from the AOA device accelerometer location to the center of rotation, and  $\Omega$  is the mean angular velocity of the AOA device. Equation (2) is applicable for  $n$  degrees of freedom (i.e.,  $n$  vibration modes). From Appendix A, for the model vibrating at one frequency in the pitch plane, equation (2) can be written as:

$$\text{Angle of Attack} = \sin^{-1} \left[ \frac{\text{AOA output} + \frac{4 A_z^2}{\omega^2 \pi^2 r}}{g} \right] \quad (3)$$

where  $A_z$  is the peak acceleration in the pitch direction,  $\omega$  is the natural frequency (radians) of the oscillation and  $r$  is the same as in equation (2).

Using equation (3) the estimated correction or error term can be calculated using measured  $A_y$  and  $A_z$  accelerations and different radius arms associated with the different vibration modes in pitch and yaw. For the 14 Hz and 16 Hz model/balance yaw and pitch modes the radius arm was taken to be 9.13 in., whereas for the 10 Hz sting yaw mode, the radius was taken to be 29.5 in. The 11 Hz pitch sting bending mode has a radius arm that is much higher at about 59.03 in. These radii choices were verified by modal animation studies. Thus, the AOA error as seen by the inertial sensor can be estimated by using measured lateral and pitch accelerations on the AOA device, associated vibration mode frequencies, and rotation radii.

Utilizing equation A-7 and knowing the radii and frequencies associated with the modes of vibration studied for this test, the estimated AOA error was calculated and compared to measured values. These comparisons are shown in figures 11 through 14. Note in figure 11 that the estimated error for the 16 Hz mode agrees very well with the measured error. The error estimates for the 14 Hz mode shown in figure 12 do not agree as well. However, the measured accelerations used for these calculations likely had additional contributions due to rolling motion as well as yawing motion since the reference accelerometers were mounted on top of the fuselage instead of at or on the AOA device which is located near the model centerline. Close observation of the 14 Hz mode (see fig. 5) shows that the rolling mode is a yaw-roll coupled mode with rolling motion amplitudes increasing at higher yaw moment load amplitudes. For this mode the calculated error is lower than the measured error by only about  $0.02^\circ$  at full scale yaw moment ( $\sim 12,000$  in-lbs., peak to peak). For the 10 Hz yaw sting mode, the comparison between estimated and measured AOA error is given in figure 13. The agreement between measured and estimated AOA error is extremely good up to about 1750 in-lbs. yaw moment (peak to peak) with a slight over prediction of the order of 0.01 degrees at a yaw moment of about 2000 in-lbs. (peak to peak). The comparison between estimated and measured error for the 11 Hz pitch sting mode is given in figure 14. Agreement is good, but as previously mentioned, the AOA response to the 11 Hz mode is small.

The estimated corrections given in figures 11 through 14 were based on using spectral analysis data from the triaxial accelerometers. No effort was made to refine the spectral data analysis or to refine the rotation radii measurements. The intent was to demonstrate that good first order estimates of AOA bias error can be obtained from modal testing and dynamic calibration which offers the potential to greatly reduce the uncertainty of the model attitude measurement in a dynamic environment.

## CORRECTION TO AOA SIGNAL IN PRESENCE OF MODEL DYNAMICS

The model oscillations in NTF, and other wind tunnels as well, are usually complex and unstationary in nature with multiple vibration modes participation. The AOA device, which is rigidly attached to the model, undergoes the same oscillations. Each oscillatory mode is caused by spring-mass characteristics of multiple degrees of freedom of the model, balance, sting, and model support. The AOA centrifugal acceleration is a complex mix of accelerations associated with all the contributing modes of motion of the model in the Y-Z plane. Each mode has its own frequency and associated radius characteristics.

The experimental work described in this paper suggests a method of estimating the angle of attack correction due to centrifugal forces acting on the device. A biaxial acceleration sensor sensitive to Y (lateral) and Z (normal) body axes needs to be mounted in or on the AOA device. This sensor will measure the motions of the AOA device package in the Y-Z plane. The lateral components of the motion can be determined by a real time spectral analysis of the signals with predetermined radii for the contributing vibration modes. This spectra can be determined either off-line or on-line using MPSS or a stand alone system. Hypothetical spectra of accelerometers mounted on the AOA devices are shown in figure 15 with four vibration modes shown in Y and Z body axes. From prior modal testing, the radii  $r_i$  associated with each mode frequency,  $\omega_i$  needs to be established so that the corrections can be made to the angle of attack output.

Let  $A_1$  to  $A_4$  be peak accelerations associated with each mode in 'g' units and  $r_1$  to  $r_4$  be radius arms associated with each mode. For each mode  $\omega_i$ , the magnitude of acceleration is  $A_i$ , i.e.,  $A_1$  to  $A_4$ , then

$$\alpha = \sin^{-1} \left[ \frac{\text{AOA output} + \sum_{i=1}^4 \frac{4 A_i^2}{\omega_i^2 \pi^2 r_i}}{g} \right] \quad (4)$$

where  $g$  is the gravitational constant,  $\omega_i$  is the natural frequency in radian/sec. Substituting  $\omega_i = 2\pi f_i$  in equation (4) gives

$$\alpha = \sin^{-1} \left[ \frac{\text{AOA output} + \sum_{i=1}^4 \frac{A_i^2}{f_i^2 \pi^4 r_i}}{g} \right] \quad (5)$$

where  $f_i$  is in Hertz.

The magnitudes of  $f_i$  and  $A_i$  are measured at each test point during wind tunnel testing whereas  $r_i$  is known a priori and assumed to stay constant. Measurement of  $f_i$  and  $A_i$  can be performed on MPSS or on a stand alone system coupled with the wind tunnel data acquisition system. The true angle of attack can then be estimated for each test point. Note that the AOA

output is assumed to be in 'g' units, if not the above expression needs to be adjusted for proper units. Further, the error and angle of attack are in radians and have to be put in required units.

A method for acquiring the necessary spectra data and making estimated corrections to the AOA output is shown in the block diagram of figure 16. By knowing the  $r_i$  value for the  $i$ th vibration mode, and the acceleration spectra which give the average angular velocity  $\Omega_i$  for each of the vibration modes, the equation shown on the figure for  $\alpha$  would be used to correct the AOA. The corrected AOA output could be transmitted to the wind tunnel data acquisition system either on-line or in a post-test manner. Note from the equation shown on figure 15, that the contribution of all the participating modes up to the  $n$ th must be summed to get the AOA correction value(s). This summation includes the vibration contributions due to both pitch and yaw motion. The number of modes that contribute significantly to the AOA bias error must be determined by pre-test experimental/analytical dynamic studies.

The magnitudes of the accelerations and/or velocities associated with the  $i$ th mode of vibration would be obtained via spectral analysis as previously indicated on figure 15. In figure 15, the peak value is obtained from the spectra at each test point during a polar (angle of attack sweep). The algorithm shown in figure 16 assumes that a high-speed, dynamic data acquisition and processing system is available and interconnected to the wind tunnel data acquisition system.

A primary issue in developing and implementing such a method is the importance of getting instantaneous values of the AOA and accelerometers output over the actual wind tunnel aerodynamic data acquisition time, which for the NTF is nominally one (1) second. Obtaining sufficient samples to capture the peak values over a 1 second period becomes a data acquisition accuracy issue, since the process may be non-stationary, (variable amplitude, multiple/varying frequencies). The application of assumed stationary analysis principles becomes questionable and will require some research to determine if, in fact, the AOA output can be corrected with a sufficient degree of accuracy, within the wind tunnel operational constraints. Any proposed on-line correction method(s) to the onboard AOA inertial device will need verification testing both in a controlled laboratory environment and during actual wind tunnel tests.

## MODEL VIBRATION EFFECTS ON DRAG MEASUREMENT

The centrifugal acceleration not only affects the inertial AOA device but can, if amplitudes are sufficiently high, affect the desired axial force or drag measurement accuracy. It is anticipated that for most models the axial centrifugal forces will be small or insignificant. However, the need to correct axial force measurements needs to be considered.

If the case should arise, the axial acceleration measurement would be required where the inertial force is given by:

$$F_{\text{axial}} = M_m a_x \quad (6)$$

where  $M_m$  is the model mass and  $a_x$  is the axial acceleration. Since multiple vibration modes can occur and may be contributing, the equation for correcting the drag measurement is given by

$$\text{DRAG FORCE}_{\text{corr.}} = \text{DRAG}_{(\text{meas.})} + W_m \sum_{i=1}^n a_{x_i} \quad (7)$$

where  $W_m$  is the weight of the model and acceleration is measured in  $g$  units, summed for  $n$  vibration modes. Corrections to drag measurement on-line or in a post-processing mode could be done in the same manner as the AOA correction.

## CONCLUDING REMARKS

Servo accelerometer sensors are excellent devices and are widely used for onboard angle of attack measurements in wind tunnels. However, when these devices are used in wind tunnel model systems in which significant structural dynamic response is present, AOA bias errors are introduced due to centrifugal accelerations associated with model vibration. This AOA bias error can be difficult to estimate and correct. An experimental study of this problem using a transport model as a testbed is presented in this paper. Significant AOA sensor bias error was found to be present when the model was subjected to variable force, sine testing at different natural frequencies of the system. The magnitude of the AOA bias error was found to be vibration mode and amplitude dependent. A first order AOA correction model was developed which uses biaxial accelerometers at the AOA sensor location to determine the centrifugal accelerations needed for computing the AOA bias error. Good correlation was obtained between the estimated bias error, (using the correction model), and measured bias error. An approach for making corrections to the AOA output, on-line during tunnel operation or in a post-processing mode, is proposed. Implementation of the proposed approach, however, raises data acquisition and processing issues associated with multiple vibration modes participation and the very short aerodynamic data acquisition time on point ( $\sim 1$  sec) during an actual test in the NTF. Corrections for axial force (drag) bias if needed, can be accomplished using a similar approach. On-line or post-processing AOA correction algorithm applications for the inertial AOA devices will likely require dynamic calibration of each model to establish the modal parameters, i.e., frequencies and radius arms for the contributing modes. Further work needs to be done to develop efficient methods for dynamic calibration and AOA data correction schemes. Model attitude measurement error due to model dynamics is not unique to the National Transonic Facility. It is important that wind tunnel facility managers, test conductors, and research engineers be aware of this potential problem. Finally, this study clearly establishes the need for examining other methods for measuring model attitude such as optical or laser, which may be less sensitive to model system dynamics.

## REFERENCES

1. Finley, T., and Tchong, P.: Model Attitude Measurements at NASA Langley Research Center. AIAA-92-0763, 1992.
2. Fuller, D. E.: Guide to Users of the National Transonic Facility. NASA TM-83124, July 1981.
3. Strganac, T. W.: A Study of the Aeroelastic Stability for the Model Support System of the National Transonic Facility. AIAA-88-2033, 1988.
4. Whitlow, W., Jr.; Bennet, Robert M.; and Strganac, T. W.: Analysis of Vibrations of the National Transonic Facility Model Support System Using a 3-D Aeroelastic Code. AIAA-89-2207, 1989.
5. Young, C. P., Jr.; Popernack, T. G.; Gloss, B. B.: National Transonic Facility Model and Model Support Vibration Problems. AIAA-90-1416, 1990.
6. Buehrle, R. D.; Young, C. P., Jr.; Balakrishna, S.; and Kilgore, W. A.: Experimental Study of Dynamic Interaction Between Model Support Structure and a High Speed Research Model in the National Transonic Facility. AIAA-94-1623, 1994.

## APPENDIX A

### DERIVATION OF EQUATIONS FOR ACCELERATIONS INDUCED AT THE AOA INERTIAL DEVICE DUE TO MODEL DYNAMICS

by

S. Balakrishna

The physics of the model motion is illustrated in figure 4. If  $a_z$  is the measured normal acceleration due to pitch vibratory oscillation of the model at one resonant frequency, then the lateral displacement of the model is obtained from the following:

$$a_z = A_z \sin \omega t \quad (\text{A-1})$$

$$v_z = \int a_z dt = \frac{A_z}{\omega} \cos \omega t \quad (\text{A-2})$$

$$x_z = \int v_z dt = -\frac{A_z}{\omega^2} \sin \omega t \quad (\text{A-3})$$

where  $A_z$  is the measured peak value of acceleration in 'g units',  $\omega = 2\pi f$ , where  $f$  is the mode frequency in Hertz. The displacement due to oscillatory acceleration,  $x_z$  is one half of peak to peak value, since  $A_z$  refers to peak acceleration. The total displacement per full cycle of motion is therefore  $4x_z$ . This motion, though not uniform, can be treated as an averaged value to arrive at the centrifugal accelerations on the sensor. If the oscillatory motion is around a known center of rotation with a radius arm of  $r$ , then the angular displacement per cycle of oscillation is

$$\text{angular motion/cycle} = \frac{A_z}{r} \left\{ 4 \int_0^{\frac{\pi}{2}} \int \sin \omega t dt dt \right\} = \frac{4x_z}{r} \text{ rad/cycle} \quad (\text{A-4})$$

$$\text{angular velocity } \Omega = \frac{4x_z}{r} \frac{\omega}{2\pi} \text{ rad/sec} \quad (\text{A-5})$$

The centrifugal acceleration is given by

$$r \Omega^2 = r \left\{ \frac{4x_z}{r} \frac{\omega}{2\pi} \right\}^2 \quad (\text{A-6})$$

Utilizing equations (A-1) and (A-3) and substituting for  $x_z$  in equation (A-6) the expression for the centrifugal acceleration becomes

$$r \Omega^2 = \frac{4 A_z^2}{\omega^2 \pi^2 r} \quad (\text{A-7})$$

Note from equation (A-7) that the acceleration is inversely proportional to the radius arm  $r$  and oscillation frequency squared, and a direct function of acceleration amplitude squared. The same type of analysis is valid for oscillations in yaw or the body Y axis. Both accelerations are assumed to act along the body X-axis (longitudinal direction) of the model. The AOA package is



assumed to be mounted on the X-axis of the model. When the model is at a finite angle of attack, the forces acting on the AOA sensor are  $g \sin\alpha$  due to attitude and  $r\Omega^2$  due to model vibration as illustrated in the vector diagram given in figure 4. If multiple radii  $r_i$  exist, each associated with a lateral acceleration  $A_i$  (either Y or Z direction), the forward centrifugal acceleration can be considered as the scalar sum of accelerations along the X-axis,  $\sum_{i=1}^n r_i \Omega_i^2$ .

**Table 1**  
**Measured Natural Vibration Mode Parameters**  
**for Transport Model/ Sting Configuration**

Mode No.	Frequency (Hz)	Damping (%)	Mode Description
1	10.28	1.01	Sting Bending (Yaw Plane)
2	11.22	1.78	Sting Bending (Pitch Plane)
3	14.35	0.463	Model Yaw/Roll on Balance
4	16.47	0.594	Model Pitch on Balance

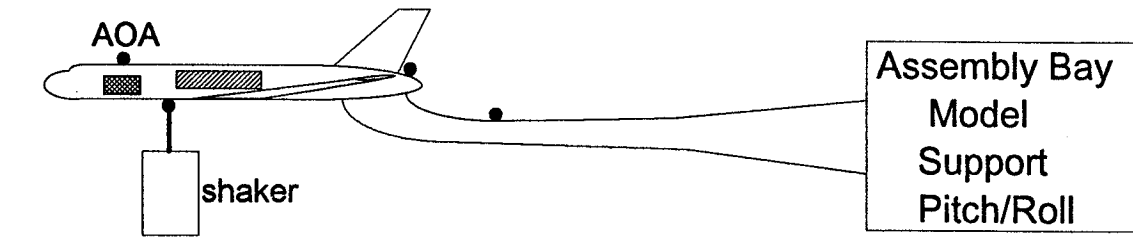

Excitation in pitch plane

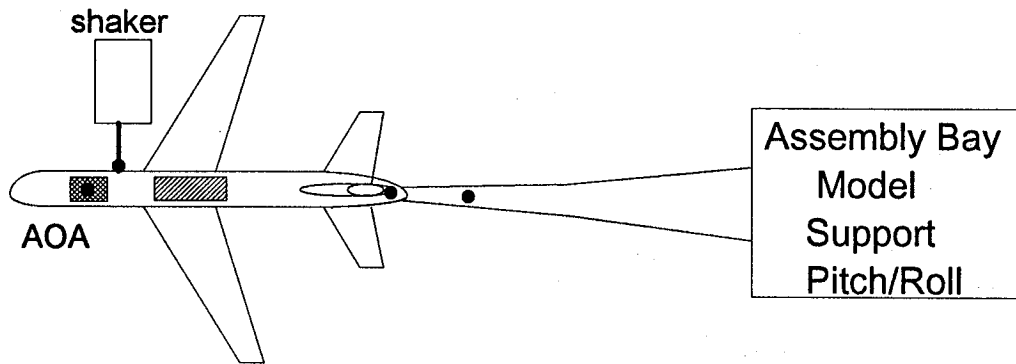

Excitation in yaw plane



-  Six component balance
-  Triaxial accelerometers and force sensors
-  Q-flex servo AOA

Figure 1. Schematic of Test Setup for Exciting Model System in the Pitch and Yaw Planes.

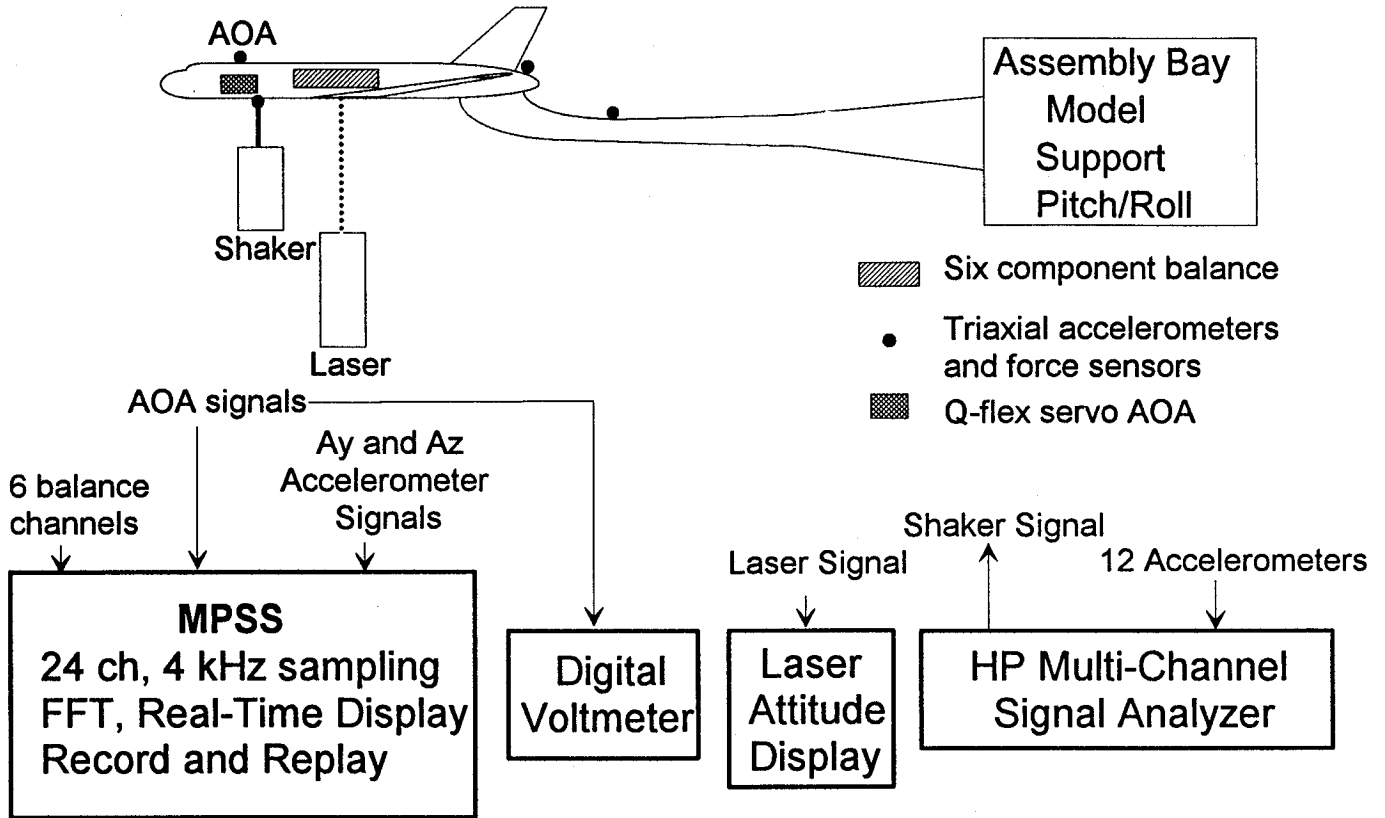

Figure 2: Instrumentation for Model AOA Dynamic Tests

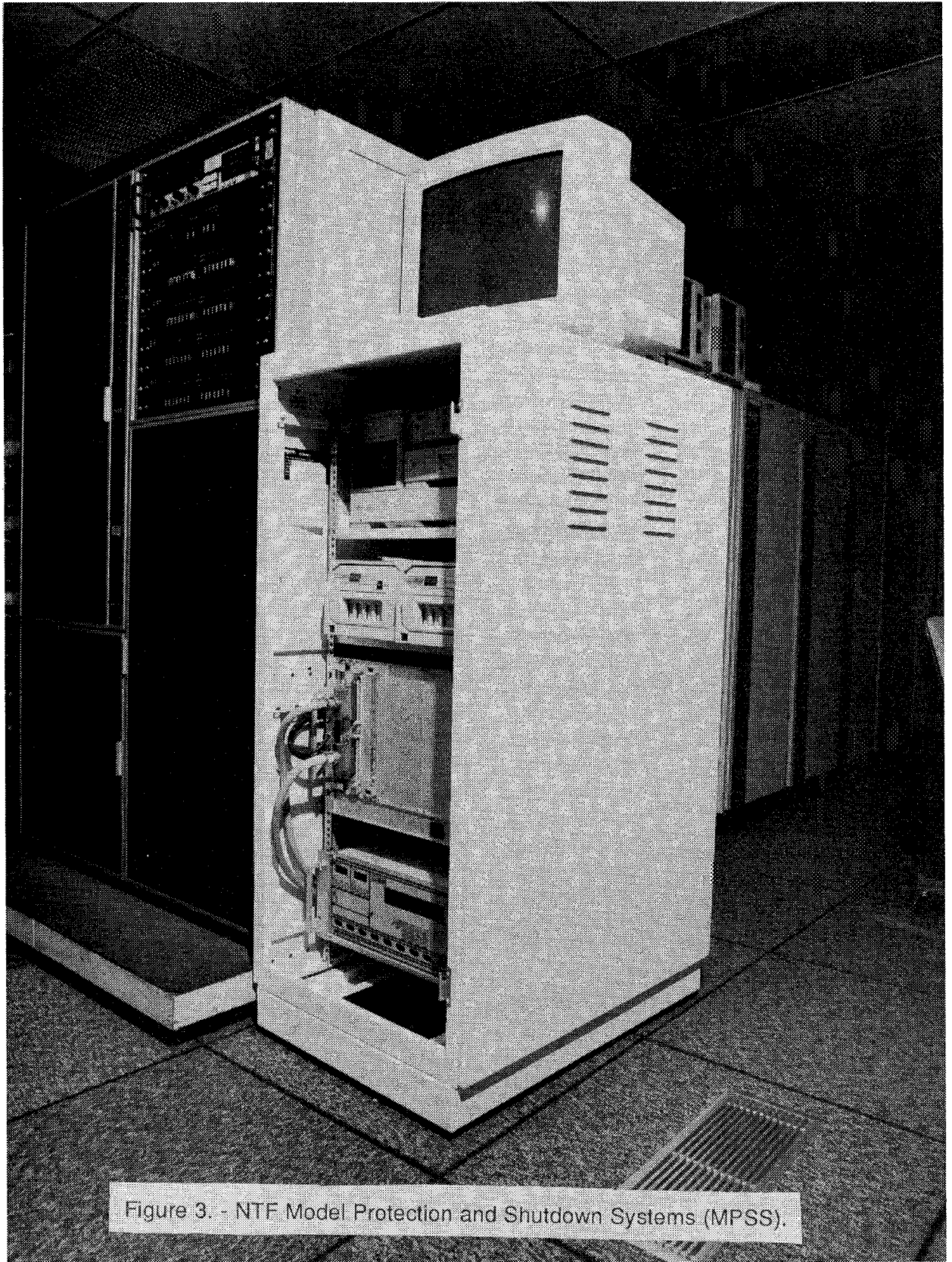
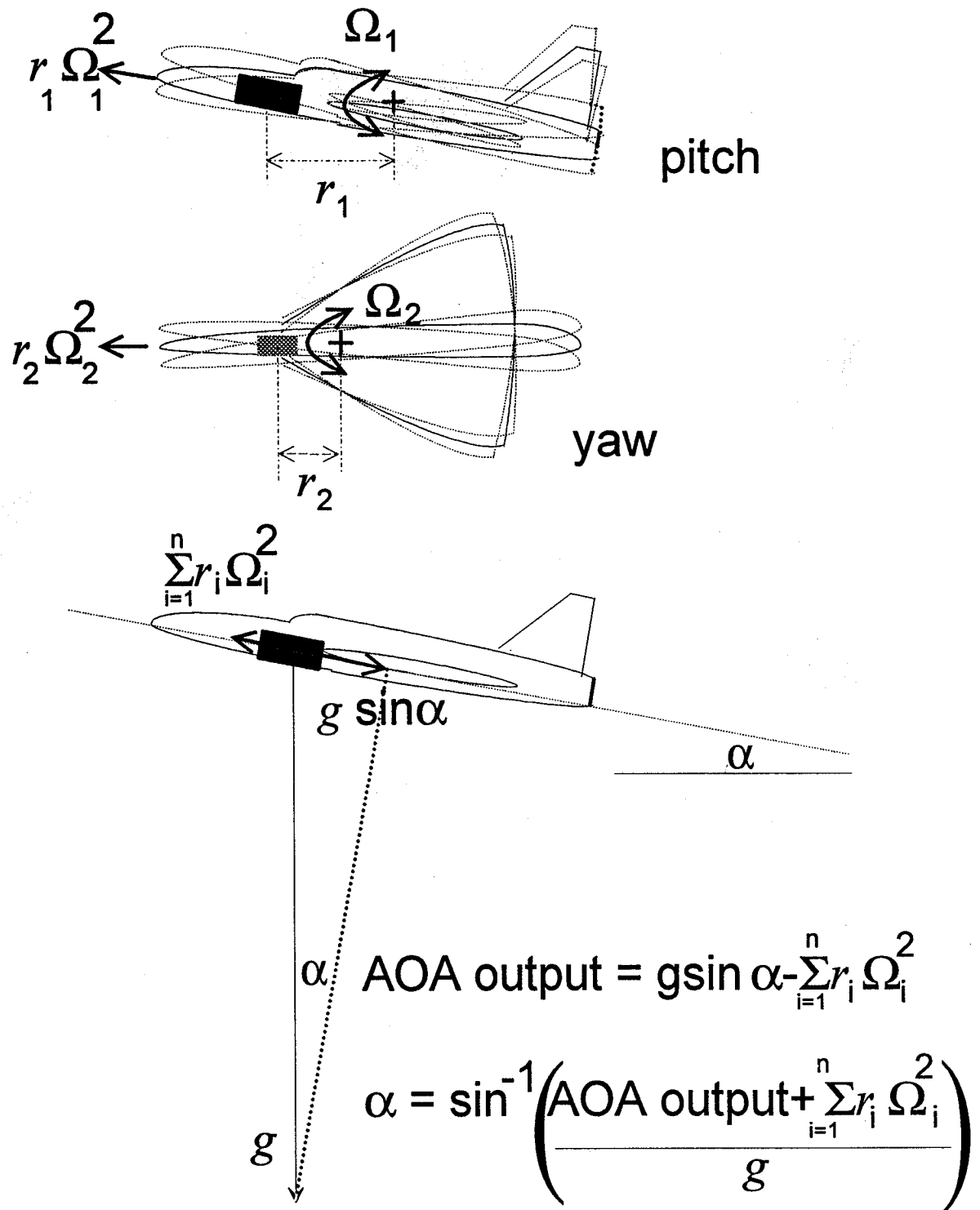

Figure 3. - NTF Model Protection and Shutdown Systems (MPSS).



$r$  = radius of rotation of vibration mode

$\Omega$  = mean angular velocity of AOA device

Figure 4. AOA bias error due to model vibration induced centrifugal acceleration.

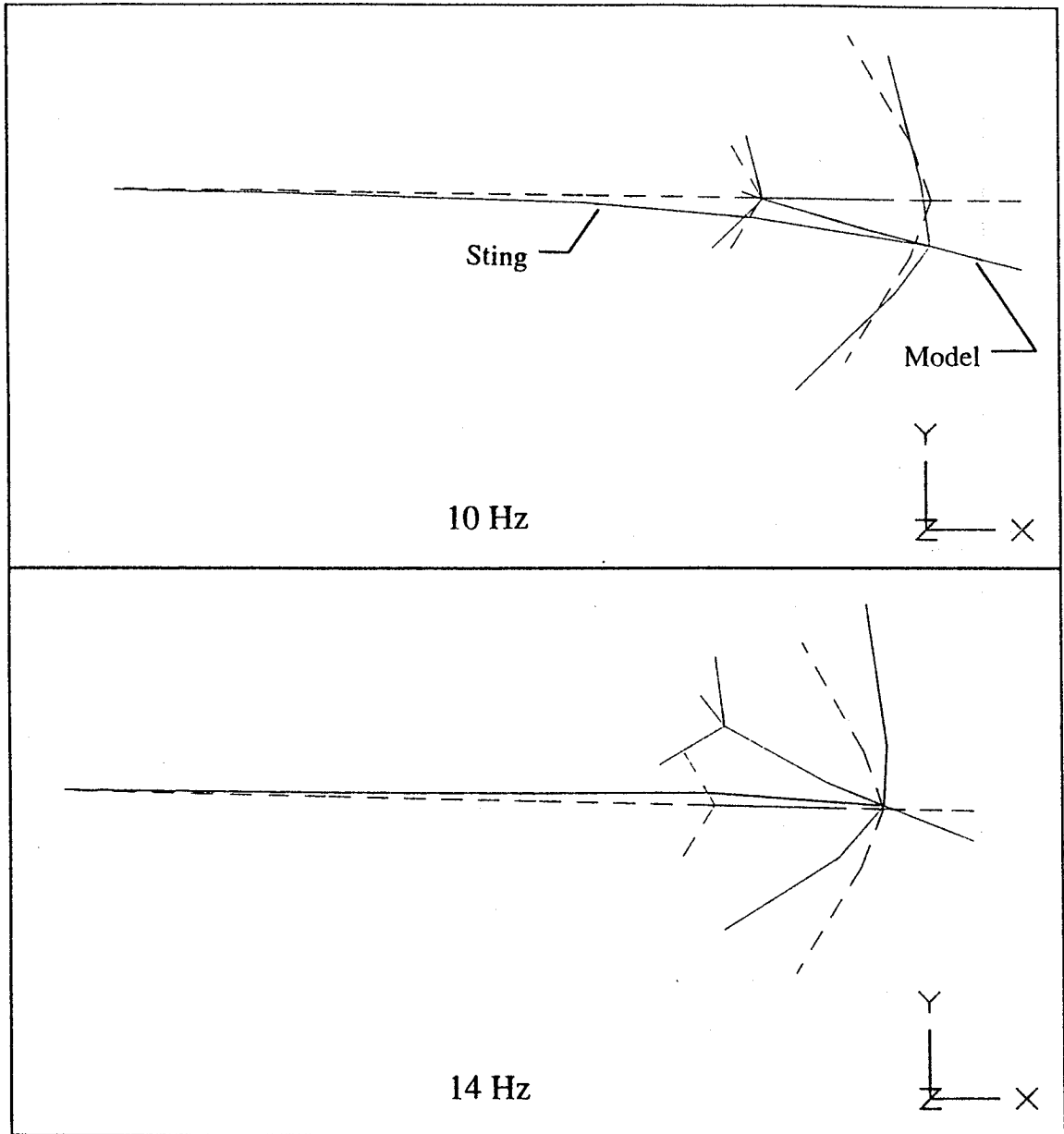

Figure 5. Yaw plane views of 10 and 14 Hz natural vibration modes for transport model. (Deformed shape —, Undeformed shape -----)

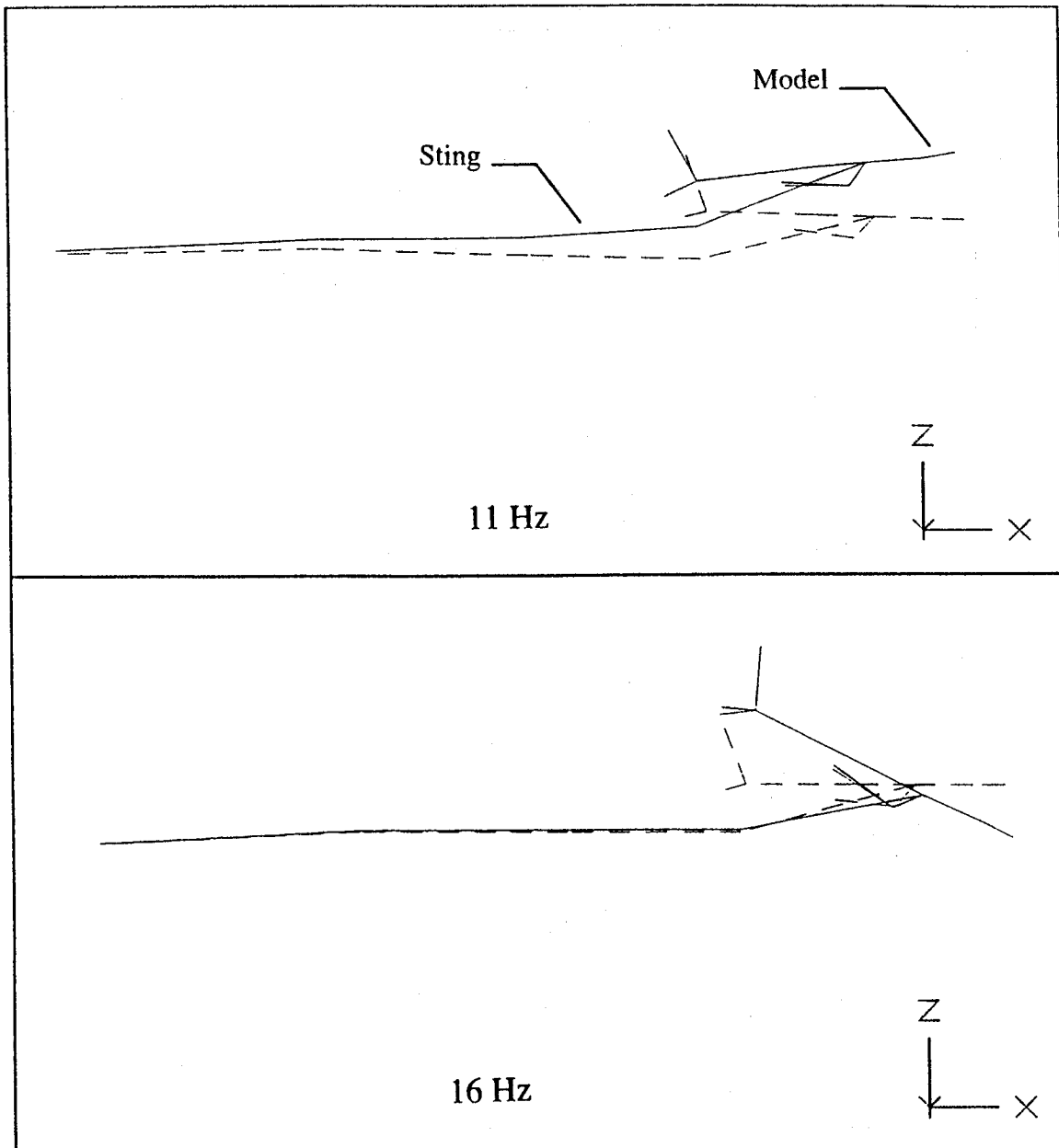

Figure 6. Pitch plane views of 11 and 16 Hz natural vibration modes for transport model.  
 (Deformed shape —, Undeformed shape -----)



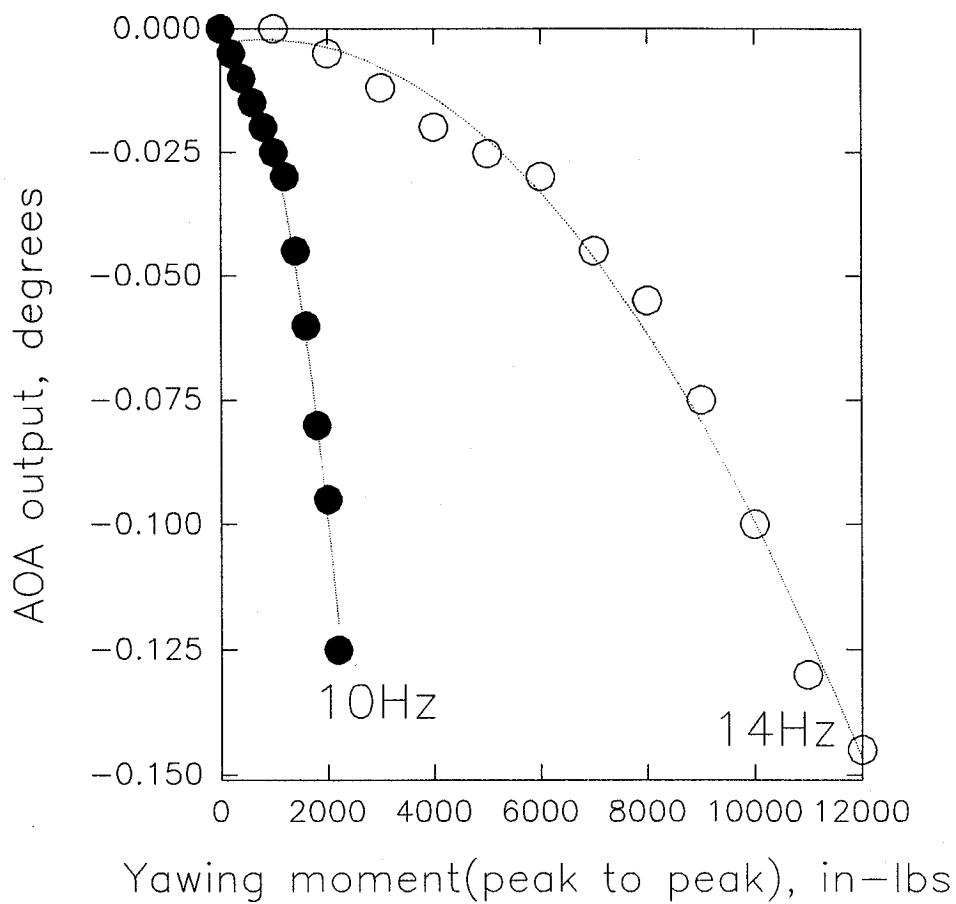
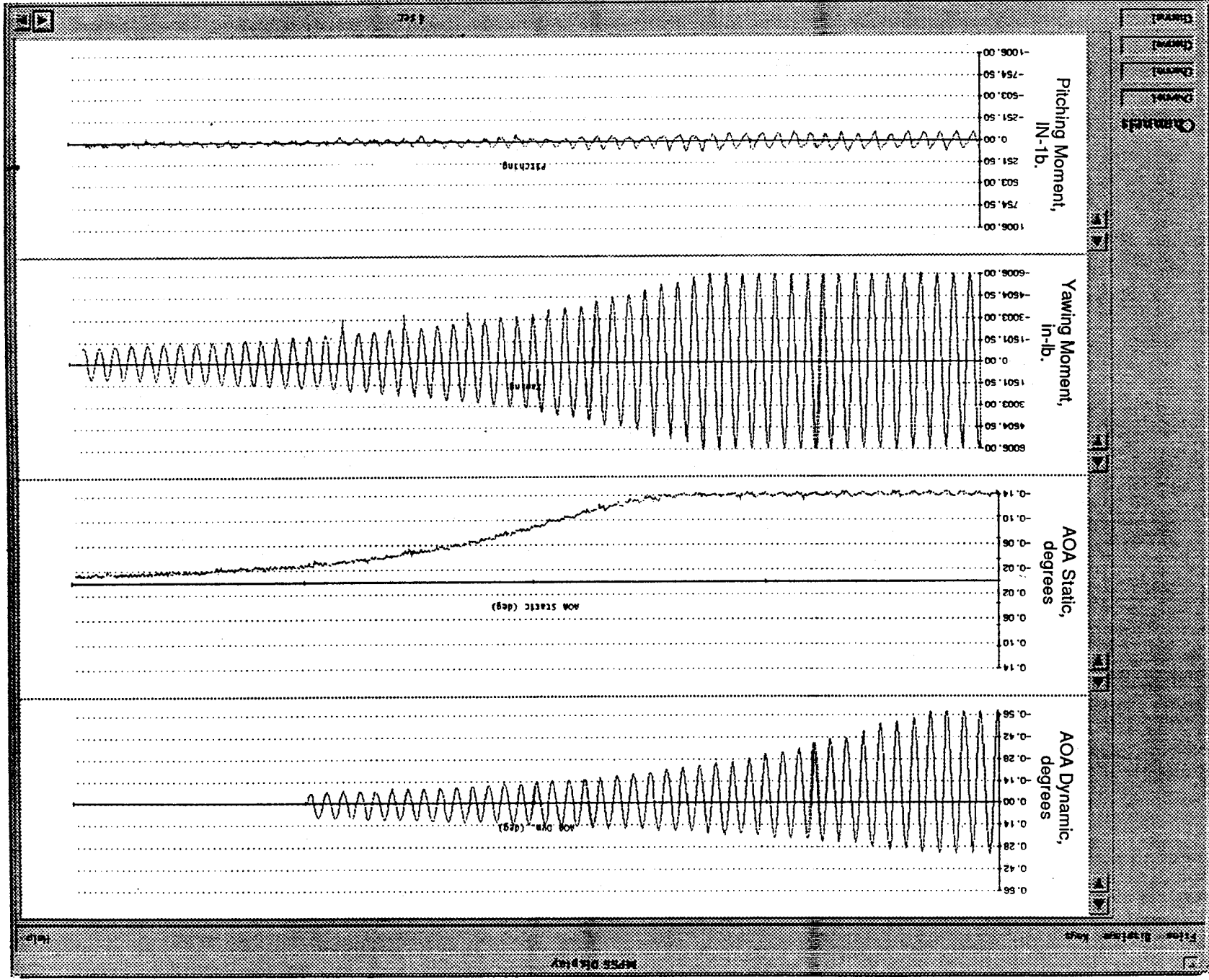

Figure 7: AOA response versus yawing moment for 10 and 14 Hz yaw vibration modes.

Figure 8. - MPSS Display Illustrating AOA Static and Dynamic Response with Yaw Moment (Due to 14 HZ Excitation) as a Function of Time.



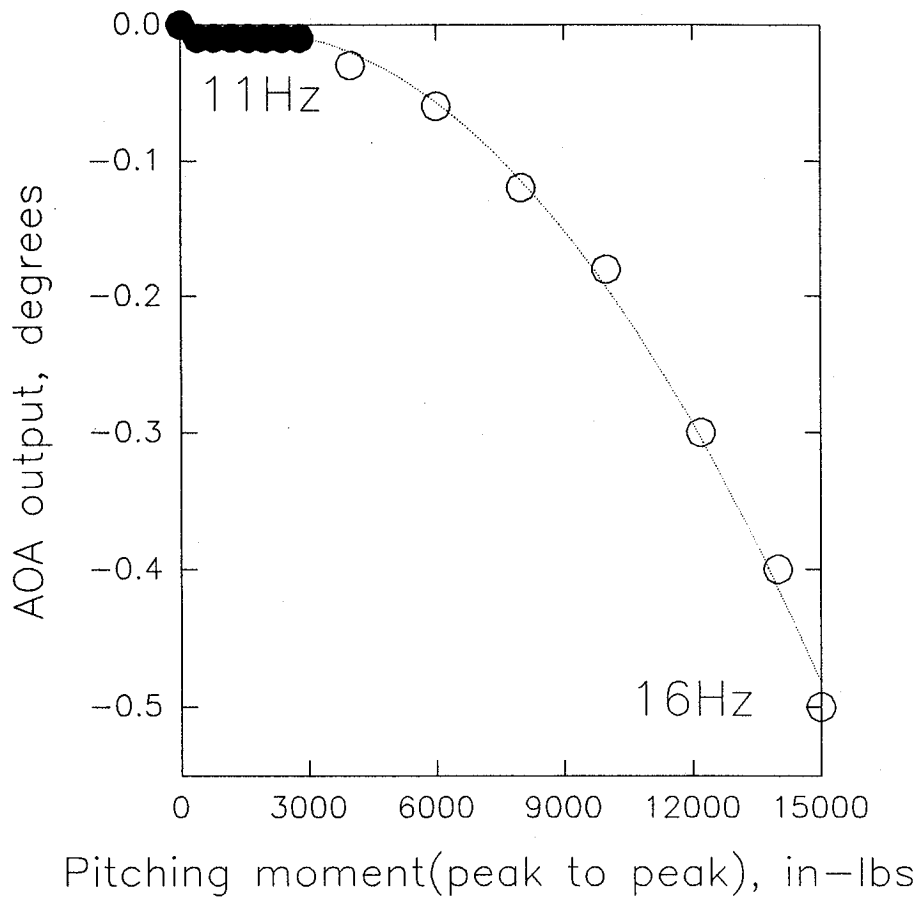

Figure 9: AOA response versus pitching moment for 11 and 16 Hz pitch vibration modes.

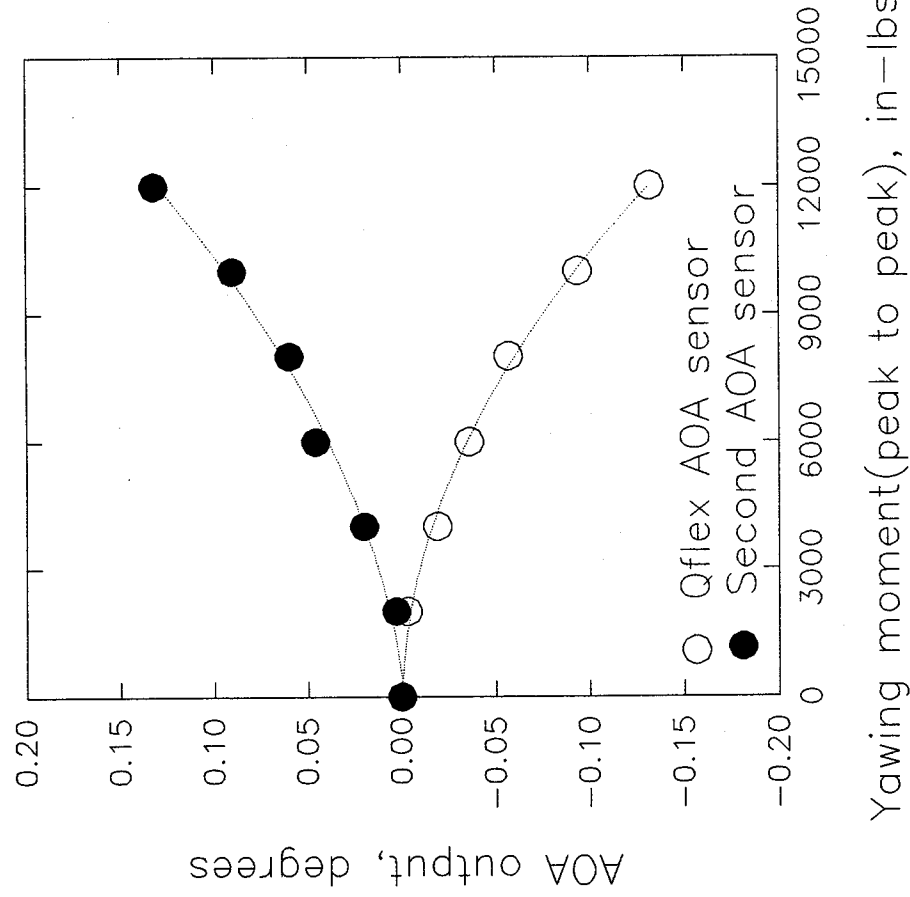
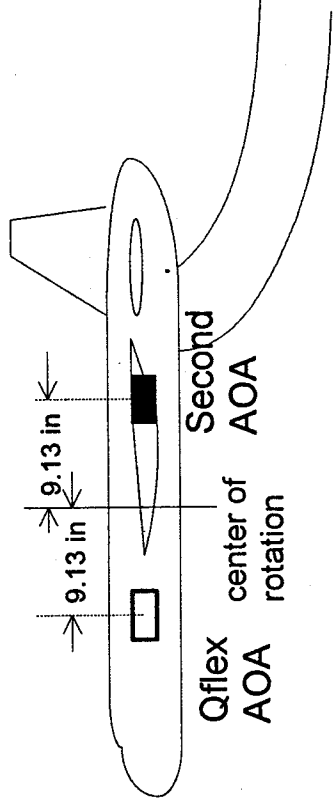

Figure 10: Response of two AOA sensors located equidistant fore and aft of the center of rotation for the 14 Hz yaw mode

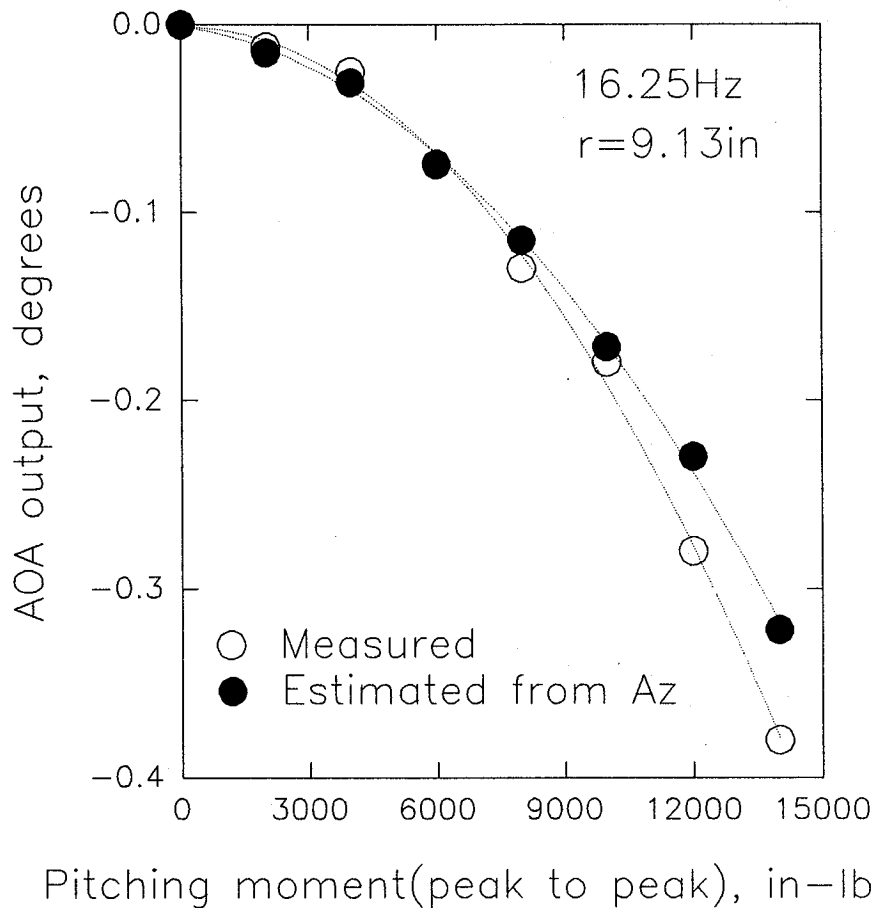
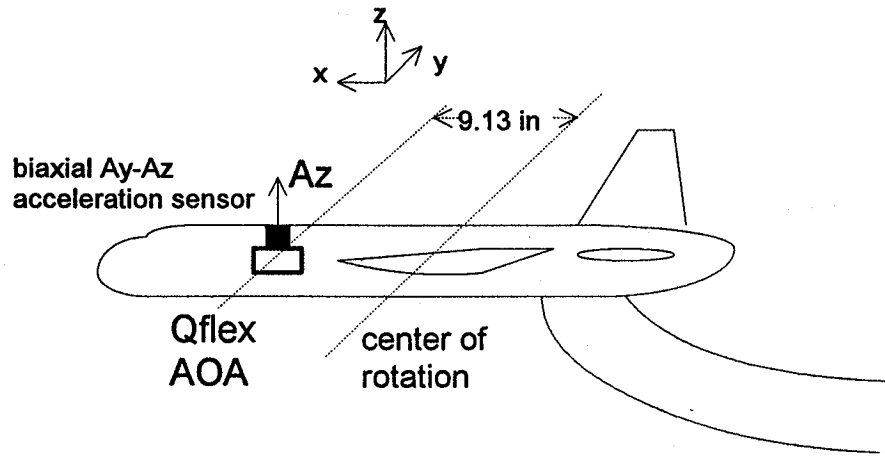

Figure 11: Measured and estimated AOA error comparisons for 16.25Hz model/balance pitch mode versus pitching moment

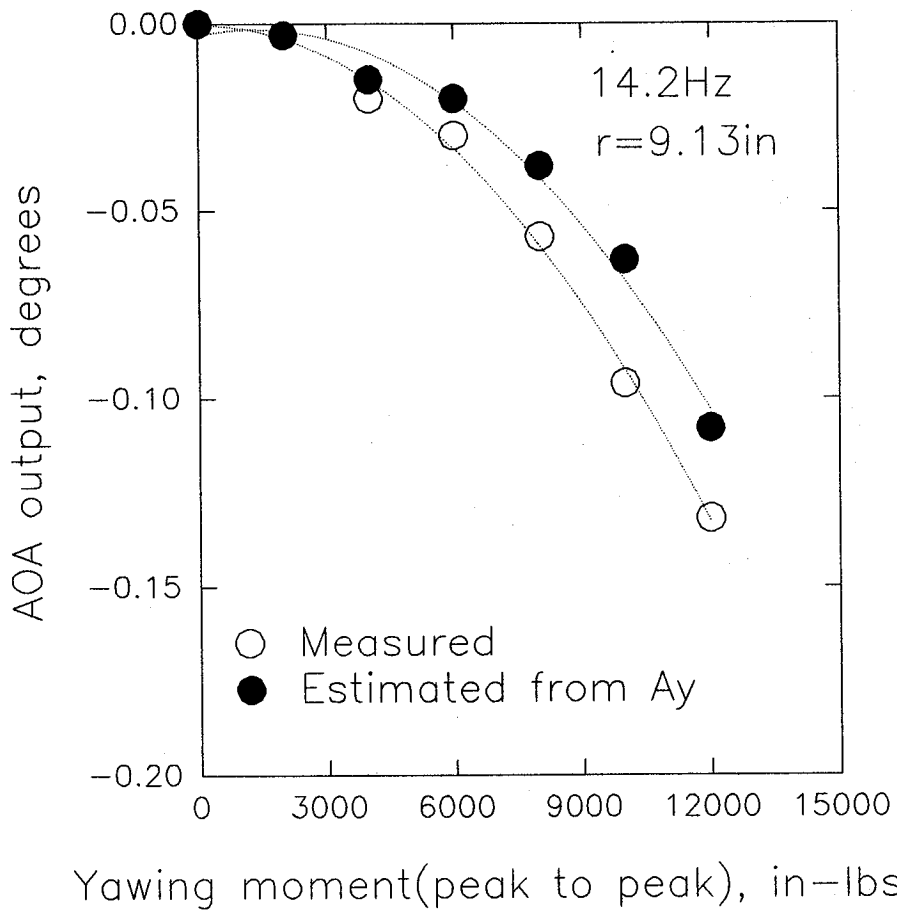
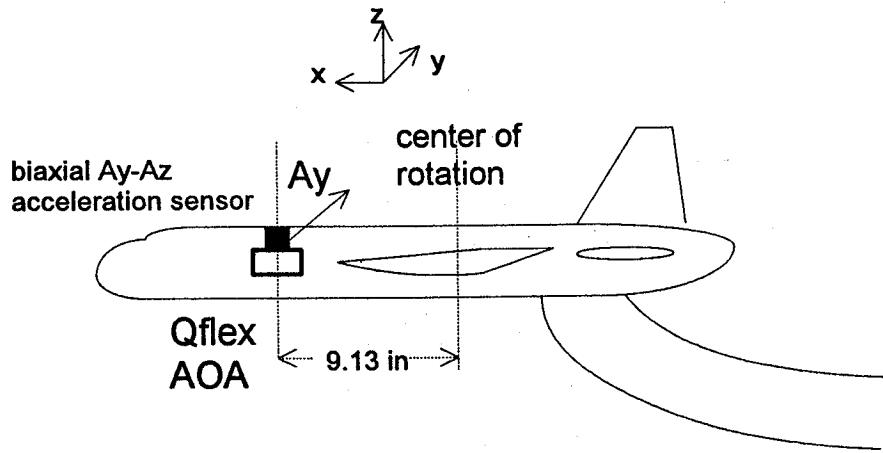

Figure12: Measured and estimated AOA error comparisons for 14.2 Hz model/balance yaw mode versus yawing moment

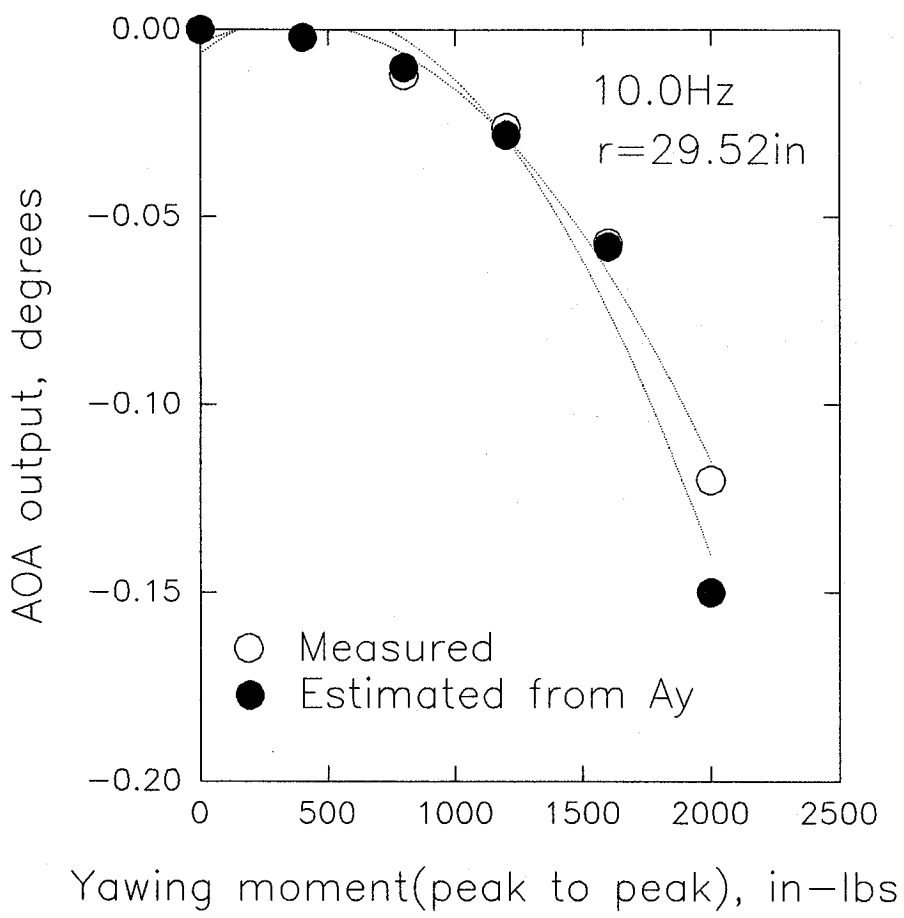
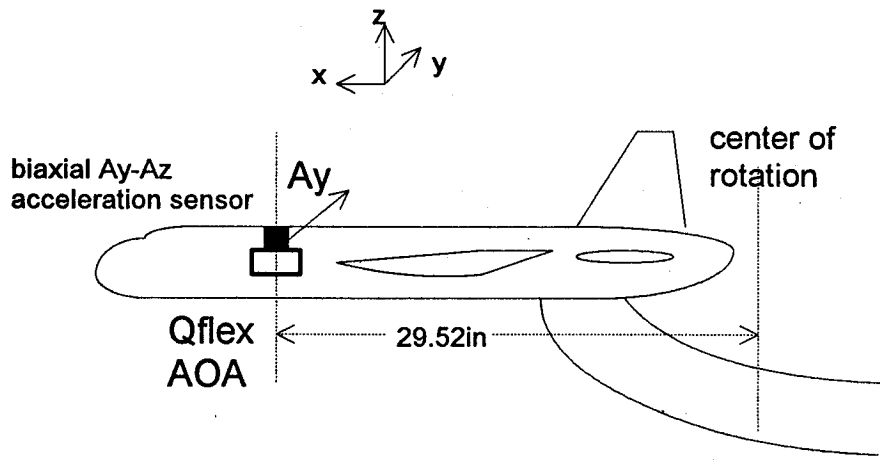

Figure13: Measured and estimated AOA error comparisons for 10 Hz yaw mode versus yawing moment

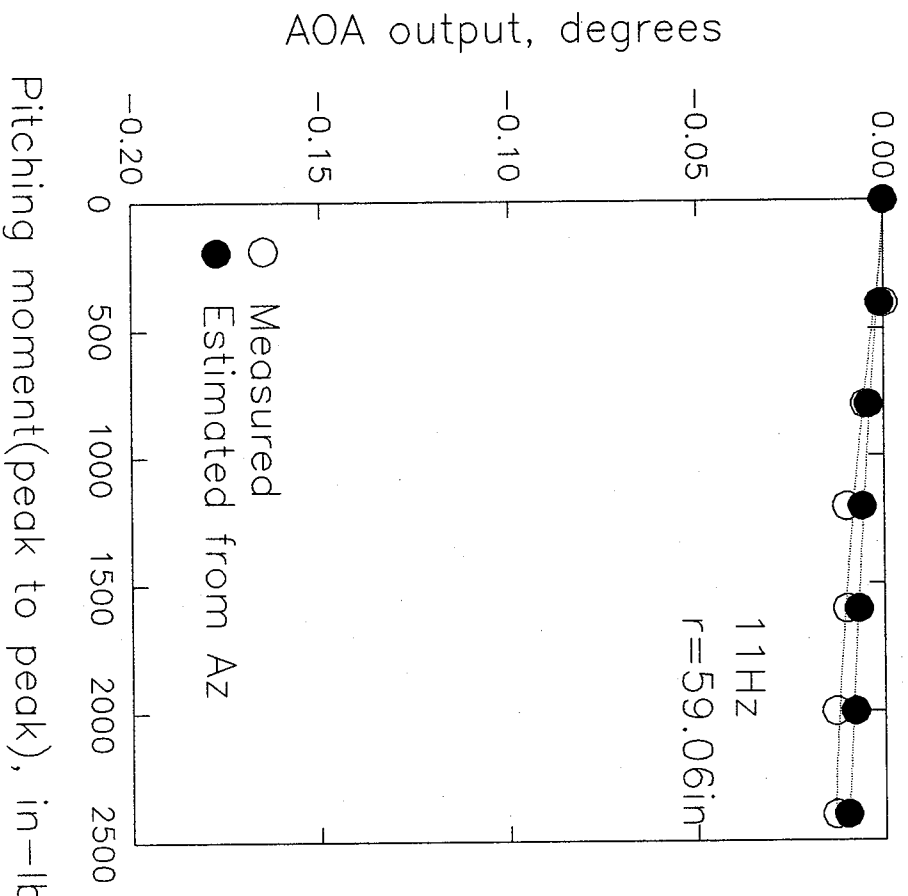
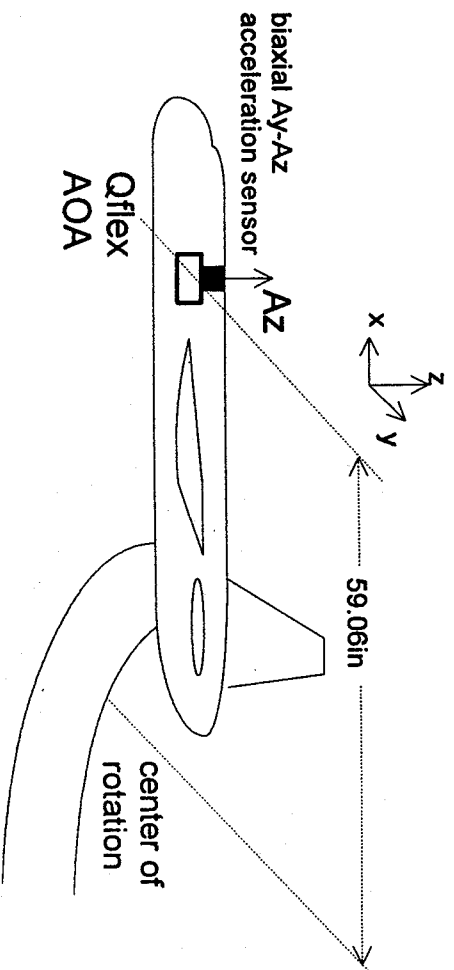
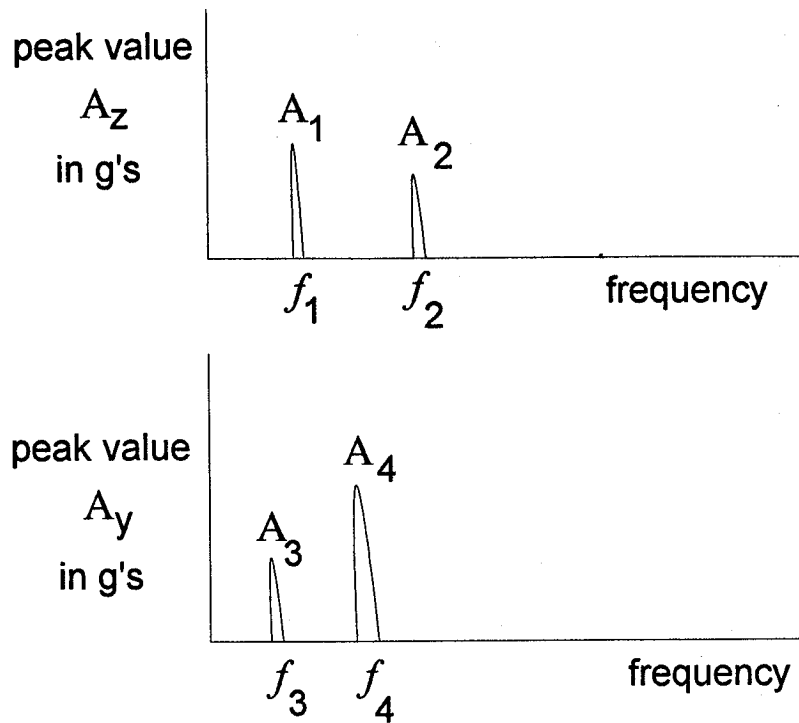

Figure 14: Measured and estimated AOA error comparisons for 11 Hz pitch mode versus pitching moment





On-line Spectra of Biaxial Accelerometers Mounted on AOA Device Package

$r_i$  = radius arm associated with each mode

$$\omega_i = 2\pi f_i$$

$$\Omega_i = \frac{2 A_i}{\omega_i \pi r_i}$$

$$\text{Total AOA}_{\text{error}} = \sum_{i=1}^4 r_i \Omega_i^2$$

$$\alpha = \sin^{-1} \left[ \frac{\text{AOA output} + \sum_{i=1}^4 r_i \Omega_i^2}{g} \right]$$

Figure 15. First order correction for AOA signal in presence of model dynamics.

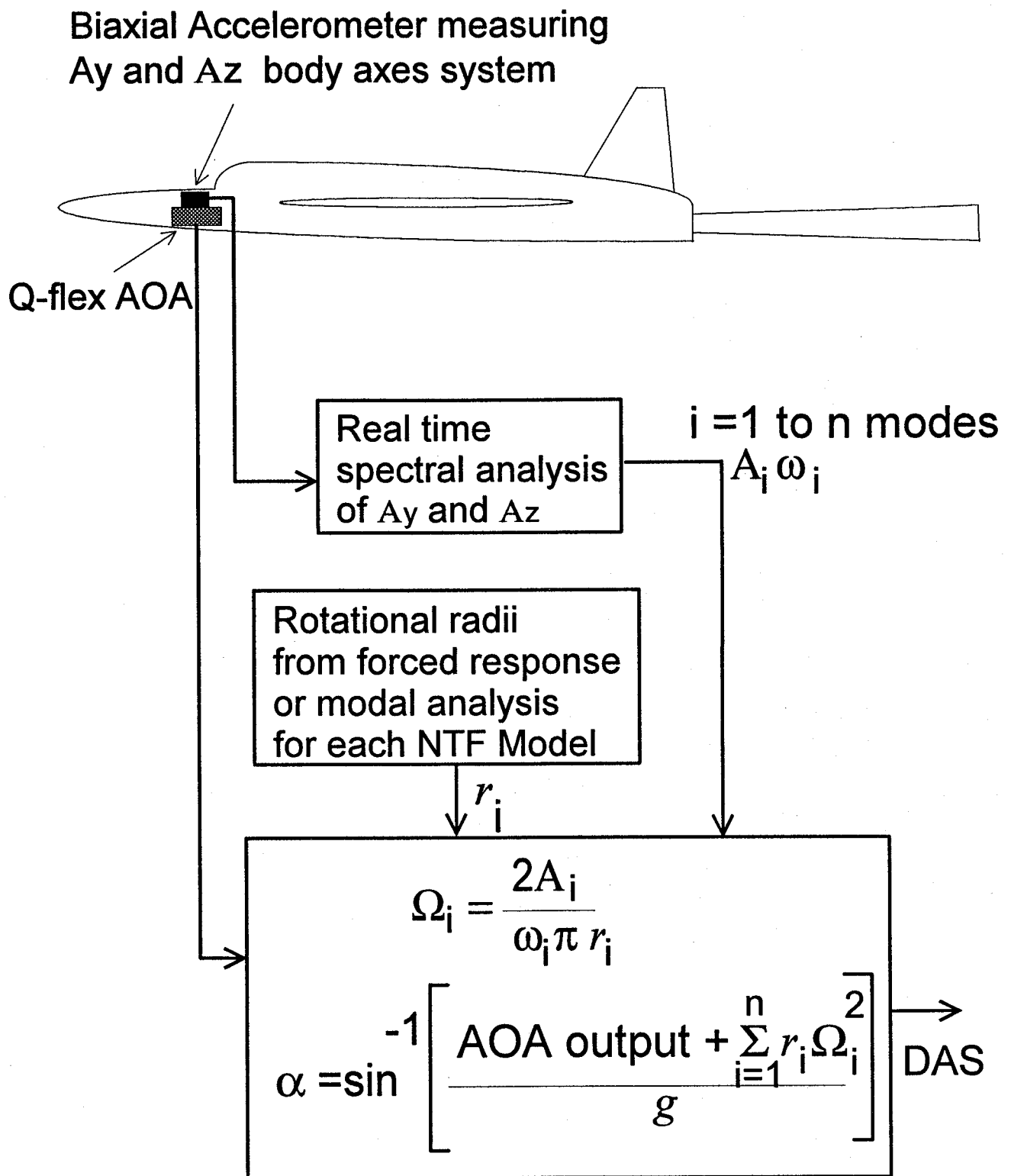

Figure 16. Schematic for making on-line corrections to AOA device output.



# REPORT DOCUMENTATION PAGE

*Form Approved*  
OMB No. 0704-0188

Public reporting burden for this collection of information is estimated to average 1 hour per response, including the time for reviewing instructions, searching existing data sources, gathering and maintaining the data needed, and completing and reviewing the collection of information. Send comments regarding this burden estimate or any other aspect of this collection of information, including suggestions for reducing this burden, to Washington Headquarters Services, Directorate for Information Operations and Reports, 1215 Jefferson Davis Highway, Suite 1204, Arlington, VA 22202-4302, and to the Office of Management and Budget, Paperwork Reduction Project (0704-0188), Washington, DC 20503.

1. AGENCY USE ONLY (Leave blank)		2. REPORT DATE July 1994	3. REPORT TYPE AND DATES COVERED Technical Memorandum	
4. TITLE AND SUBTITLE Effects of Vibration on Inertial Wind-Tunnel Model Attitude Measurement Devices			5. FUNDING NUMBERS WU 505-59-54-01	
6. AUTHOR(S) Clarence P. Young, Jr., Ralph D. Buehrle, S. Balakrishna, and W. Allen Kilgore				
7. PERFORMING ORGANIZATION NAME(S) AND ADDRESS(ES) NASA Langley Research Center Hampton, VA 23681-0001			8. PERFORMING ORGANIZATION REPORT NUMBER	
9. SPONSORING / MONITORING AGENCY NAME(S) AND ADDRESS(ES) National Aeronautics and Space Administration Washington, DC 20646-0001			10. SPONSORING / MONITORING AGENCY REPORT NUMBER NASA TM-109083	
11. SUPPLEMENTARY NOTES Young: North Carolina State University, Raleigh, NC; Buehrle: Langley Research Center, Hampton, VA; Balakrishna and Kilgore: ViGYAN, Inc., Hampton, VA				
12a. DISTRIBUTION / AVAILABILITY STATEMENT Unclassified - Unlimited  Subject Category 09			12b. DISTRIBUTION CODE	
13. ABSTRACT (Maximum 200 words)  Results of an experimental study of a wind tunnel model inertial angle-of-attack sensor response to a simulated dynamic environment are presented. The inertial device cannot distinguish between the gravity vector and the centrifugal accelerations associated with wind tunnel model vibration which results in a model attitude measurement bias error. Significant bias error in model attitude measurement was found for the model system tested. The model attitude bias error was found to be vibration mode and amplitude dependent. A first order correction model was developed and used for estimating attitude measurement bias error due to dynamic motion. A method for correcting the output of the model attitude inertial sensor in the presence of model dynamics during on-line wind tunnel operation is proposed.				
14. SUBJECT TERMS  Wind tunnel model vibrations; Model attitude bias error; Inertial angle of attack sensors; Angle of attack correction algorithm			15. NUMBER OF PAGES 33	
			16. PRICE CODE A03	
17. SECURITY CLASSIFICATION OF REPORT Unclassified	18. SECURITY CLASSIFICATION OF THIS PAGE Unclassified	19. SECURITY CLASSIFICATION OF ABSTRACT Unclassified	20. LIMITATION OF ABSTRACT	