

(NASA-CR-196839) COAXIAL MICROWAVE  
ELECTROTHERMAL THRUSTER PERFORMANCE  
IN HYDROGEN (Michigan State Univ.)  
11 p

N95-11584

Unclas

G3/20 0022680

1/10/2  
22080

## Coaxial Microwave Electrothermal Thruster Performance in Hydrogen

W. Richardson\* and J. Asmussen+

Michigan State University, East Lansing, Michigan

### Introduction

The microwave electrothermal thruster (MET) is an electric propulsion concept that offers the promise of high performance combined with a long lifetime<sup>1-3</sup>. An unique feature of this electric propulsion concept is its ability to create a microwave plasma discharge separated or floating away from any electrodes or enclosing walls. This allows propellant temperatures that are higher than those in resistojets and reduces electrode and wall erosion. It has been demonstrated that microwave energy is coupled into discharges very efficiently at high input power levels<sup>2,3,8</sup>. As a result of these advantages, the MET concept has been identified as a future high power electric propulsion possibility<sup>5</sup>.

Initial MET thruster experimentation employed two basic microwave coupling devices. It was first demonstrated using a coaxial applicator<sup>1</sup>. Microwave energy at 2.45 GHz created a plasma discharge at the end of a 50 ohm coaxial line. The plasma was confined by a quartz discharge chamber and teflon vacuum window, and the heated gas was expanded through a quartz nozzle. Benchmark experiments in nitrogen with absorbed power from 200-500 Watts produced a specific impulse of 150-230 seconds. Energy efficiencies ranged from 30-60% as flow rates varied from  $6.4 \times 10^{-6}$  kg/s to  $11.7 \times 10^{-6}$  kg/s.

Later experiments utilized a cylindrical cavity which was excited at 2.45 GHz in the  $TM_{012}$  cavity mode<sup>2,3</sup>. The cavity applicator used a quartz discharge chamber and either a quartz or metal nozzle. Experiments using a quartz nozzle produced a specific impulse reaching 280 seconds in nitrogen and 600 seconds in helium. Input microwave energy varied from 500-2000 Watts, and the variable cavity tuning system allowed virtually no power to be reflected back into the microwave source. Energy efficiencies were in the range of 10-50%. When a metal nozzle was incorporated into the cavity design, specific impulse in nitrogen was

\*Graduate Assistant, Department of Electrical Engineering

+Professor and Chairperson, Member AIAA, Department of Electrical Engineering,  
Michigan State University, East Lansing, MI 48824-1226

improved to 325 seconds. Currently, diagnostics on the cavity discharges are being continued at Michigan State University<sup>4</sup>, and a 915 MHz resonant cavity MET with a magnetic nozzle is being developed at the NASA Lewis Research Center<sup>5</sup>.

Since its introduction, significant improvements have been made to the coaxial MET<sup>6</sup>. The quartz discharge chamber was replaced by a brass discharge chamber and an inconel nozzle was installed. The cylindrical brass discharge chamber is compact, with a volume of approximately 300 cm<sup>3</sup>, and serves as both a guide for the microwave energy and a confinement chamber for the plasma discharge. With these improvements specific impulse in nitrogen was increased to 270 seconds. Helium propellant was also used, and specific impulse reached 450 seconds. Efficiencies from 20-60% resulted and input power levels reached 1250 Watts. Flow rates were increased to  $187 \times 10^{-6}$  kg/s for nitrogen and helium experiments were conducted at a flow rate of  $26.8 \times 10^{-6}$  kg/s.

Recently, two additional improvements have been made to the coaxial MET. The first was concerned with improving the microwave matching. Previous experiments were conducted with 10-30% reflected power when incident power was in excess of 600 W<sup>6</sup>. Power was reflected back to the generator because the impedance of the MET did not match the 50 ohm impedance of the microwave circuit. To solve this problem, a double stub tuning system has been inserted between the MET and the microwave power supply. The addition of the double stub tuners reduces the reflected power below 1%.

The other improvement has prepared the coaxial MET for hydrogen experiments. To operate with hydrogen, the vacuum window which separates the coaxial line from the discharge chamber has been changed from teflon to boron nitride. All the microwave energy delivered to the plasma discharge passes through this vacuum window. This material change had caused problems in the past because of the increased microwave reflection coefficients associated with the electrical properties of boron nitride. However, by making the boron nitride window electrically one-half of a wavelength long, power reflection from the window has been eliminated. This technical note summarizes the experimental performance of the improved coaxial MET when operating in nitrogen, helium, and hydrogen gases.

#### Description of the Coaxial Applicator

Figure 1 displays a simplified diagram of the coaxial MET and microwave tuning circuit. Microwave energy from the power source enters the double stub tuning circuit (1) and passes through the tuners to the 50 ohm coaxial coupling structure (2). The double stub

tuners transform the impedance of the MET so that nearly all the incident power is coupled into the MET/stub microwave circuit<sup>9</sup>. The third tuning stub (3) is held in a fixed position as shown in the diagram. After the microwave power is matched into the MET/stub microwave circuit, high standing wave fields exist in the coaxial coupling circuit, including the one-half wavelength boron nitride vacuum window (4) and the discharge chamber (5). The boron nitride window isolates the discharge chamber from the atmospheric pressure air in the coaxial line.

The propellant enters the discharge chamber through three holes in the boron nitride window (6) which have been designed to swirl the gas into a vortex. This gas input method has been shown to stabilize the plasma discharge (7). The plasma discharge is created between the inconel coaxial tip (8) and the nozzle (9). The brass center conductor (10) is designed so the distance between the nozzle and the coaxial tip can be varied, and thus the length of the discharge is adjustable. Generally the length of the plasma ranges between 2.2 and 4.0 centimeters. Once the gas passes through the discharge it is heated and is expanded through the nozzle into a vacuum system which is sealed with a stainless steel base plate (11). Water cooling (12) is used to cool the base plate (11), coaxial tip (8), and outer conductor (13). The water cooling is necessary to protect the numerous hard solder joints and O-rings in both the stainless steel nozzle assembly and brass coaxial applicator. Finally, there is a view port (14) with a Plexiglas glass window which is used for visual inspection of the plasma discharge.

### Experimental Procedure and Results

The experimental microwave circuits, the gas flow and vacuum systems, and the experimental measurement techniques are similar to those that have been described elsewhere<sup>1-3,8,9</sup>. Experimental thrust, energy efficiency, and specific impulse were calculated from measurements of hot and cold discharge chamber pressures under constant flow conditions<sup>2,10</sup>. This method of calculating performance requires that the nozzle be operated under choked flow conditions and has been verified for accuracy under experimental conditions<sup>2,8,10</sup>.

The plasma discharge was ignited by adjusting the center conductor until the length between the coaxial tip and nozzle was approximately 2.2 cm. The propellant flow was then set so the discharge chamber had a pressure of approximately 10 mmHg. With these ignition conditions, about 400 Watts of incident microwave power was required to start the discharge.

After ignition, power and gas flow were increased to the desired operating point. The stub tuners were then adjusted for minimum reflected power and the discharge length was set for optimum specific impulse.

Experimental runs were performed by establishing a desired propellant flow rate and holding this flow rate constant throughout the entire experimental run. Before the discharge was ignited, the cold discharge pressure was measured at the desired flow rate. The discharge was then ignited and the input microwave power was adjusted to the desired level. The steady state hot discharge pressures were measured for several operating points as the input power was varied. After each experimental run, the discharge chamber was allowed to cool back to the initial conditions, and the cold discharge pressure was measured again at the same flow rate to check against nozzle degradation.

Figure 2 summarizes performance for seven typical experimental runs carried out in nitrogen, helium, and hydrogen, and Table 1 contains general information on the operating conditions during these experimental runs. Two nozzles were available, with minimum throat areas of 0.635 mm and 1.02 mm. Only the small nozzle was used in hydrogen experiments. Safety considerations limited hydrogen flow rates to  $4.47 \times 10^{-6}$  kg/s and required that discharge chamber pressure be kept below 500 mmHg. Specific impulse in hydrogen reached 740 seconds as power increased to almost 950 Watts, and energy efficiencies were between 10-20%. Although limited to low hot discharge pressures and low flow rates, the performance displayed in Figure 2 clearly demonstrates the possibility of high specific impulse with hydrogen gas propellants.

Helium experiments were conducted with both nozzle sizes. The 0.635 mm nozzle produced the best specific impulse for helium at 530 seconds. Efficiency was 30% and input power was 870 Watts. Better operating points resulted when the 1.02mm nozzle was used with helium, however. At the highest flow rate,  $38.6 \times 10^{-6}$  kg/s, an operating point with 450 seconds of impulse and 40% efficiency was found. The reflection coefficient was 0.5%, since only 4 Watts of the 870 Watts of input power was reflected back to the microwave power source.

Experiments using nitrogen propellant were conducted extensively. Efficiencies exceeded 50% and specific impulse was taken to 260 seconds. Hot plasma pressure rose to 2050 mmHg and absorbed power levels reached nearly 900 Watts. It was experimentally observed during the nitrogen experiments that shortening the discharge length increased

specific impulse. This distance was critical however, because if discharge length was too short, the plasma would move onto the coaxial tip and erode it. This situation was not observed in either the helium or hydrogen experiments, and proper positioning of the discharge eliminated erosion when nitrogen was used. The one experimental run in nitrogen of particular interest was conducted at a flow rate of  $146 \times 10^{-6}$  kg/s. This run demonstrates that operating regions do exist where an increase in power can cause an increase in impulse without a decrease in efficiency.

### Discussion

Redesign of the coaxial MET has resulted in improved performance. The teflon vacuum window and quartz discharge chamber which both become chemically active in hydrogen environments was replaced in the design. This allowed experiments to proceed with hydrogen. Double stub tuning was added and reflected power problems were eliminated. These design changes improved specific impulse and energy efficiency in helium and nitrogen, and the operation in hydrogen resulted in a specific impulse of 740 seconds. This is the best specific impulse achieved by a MET.

An estimated 50 hours of experimentation was conducted with each nozzle and no erosion was observed. This was confirmed by both visual inspection and comparison of the cold flow discharge chamber pressures over time. Discharge pressures in nitrogen and helium were high, nearly three atmospheres, and there appears to be no fundamental limit on how high this pressure may be taken. This is important because high pressure discharges result from high propellant flow rates, which in turn improve efficiency. The discharge chamber is compact, as is required for space applications, and plasma created inside the discharge chamber is inherently stable.

However, additional improvements are possible. The nozzle and discharge chamber can be made of higher temperature materials. Both the solder joints in the nozzle and the O-rings used in the baseplate assembly should be eliminated. These changes would allow operation with higher input power and would reduce the need for water cooling. Higher temperature nozzles and higher input powers will increase specific impulse. MET performance should greatly improve, especially in hydrogen, at higher pressures and flow rates. A more compact and better tuning circuit would reduce the size of the thruster and in turn reduce electromagnetic losses. Finally, with improved understanding of the thruster it may be possible to move the plasma discharge away from the coaxial conductor tip.

### Acknowledgement

This work was supported by NASA Grant NAG3-760.

### References

1. Whitehair, S., Asmussen, J., and Nakanishi, S., "Demonstration of a New Electrothermal Thruster Concept," *Applied Physics Letters*, Vol. 44, May 1984, pp. 1014-1016.
2. Asmussen, J., Whitehair, S., and Nakanishi, S., "Experiments with a Microwave Electrothermal Thruster Concept," *AIAA/JSASS/DGLR 17th International Electric Propulsion Conference, IEPC 84-74*, Tokyo, Japan, May 1984.
3. Whitehair, S., Asmussen, J., and Nakanishi, S., "Microwave Electrothermal Thruster Performance in Helium Gas," *Journal of Propulsion and Power*, Vol. 3, March-April 1987, pp. 136-144.
4. Hawley, M.C., Asmussen, J., Filpus, J.W., Whitehair, S., Hoekstra, C., Morin, T.J., and Chapman, R., "Review of Research and Development on the Microwave Electrothermal Thruster," *Journal of Propulsion and Power*, Vol. 5, Nov.-Dec. 1989, pp.703-712.
5. Power, J.L., and Chapman, R.A., "Development of a High Power Microwave Thruster, With a Magnetic Nozzle, for space applications," *NASA TM 102321*; also presented at the 24th Microwave Power Symposium, Aug. 1989.
6. Asmussen, J., and Whitehair, S., "Experiments and Analysis of a Compact Electrothermal Thruster," *Proceedings of the DGLR/AIAA/JSASS 20th International Electric Propulsion Conference, DGLR Paper 88-101*, Oct. 1988.
7. Micci, M.M., "Prospects of Microwave Heated Propulsion," *AIAA Paper 84-1390*, June 1984.
8. Whitehair, S., "Experimental Development of a Microwave Electrothermal Thruster," *Ph.D. Dissertation, Michigan State University, 1986*.
9. Collin, R.E., "Foundations of Microwave Engineering," *McGraw-Hill, New York, 1966*, pp. 203-258.
10. Hawkins, C.E., and Nakanishi, S., "Free Radical Propulsion Concept," *NASA TM-81770*; also *AIAA Paper 81-0676*.

**Figure Captions**

**Fig. 1 Cross Section of the coaxial electrothermal thruster:** (1) double stub tuning circuit, (2) coaxial coupling structure, (3) tuning stub, (4) boron nitride vacuum window, (5) discharge chamber, (6) gas input, (7) microwave discharge, (8) coaxial tip, (9) nozzle, (10) center conductor, (11) vacuum base plate, (12) water cooling, (13) outer conductor, and (14) view port. The incident power,  $P_i$ , and the reflected power,  $P_r$ , are also indicated on the diagram.

**Fig. 2 Energy efficiency vs. specific impulse for the different experimental conditions listed in Table 1.**

**Table 1 Experimental conditions for Figure 1.**

ORIGINAL PAGE IS  
OF POOR QUALITY



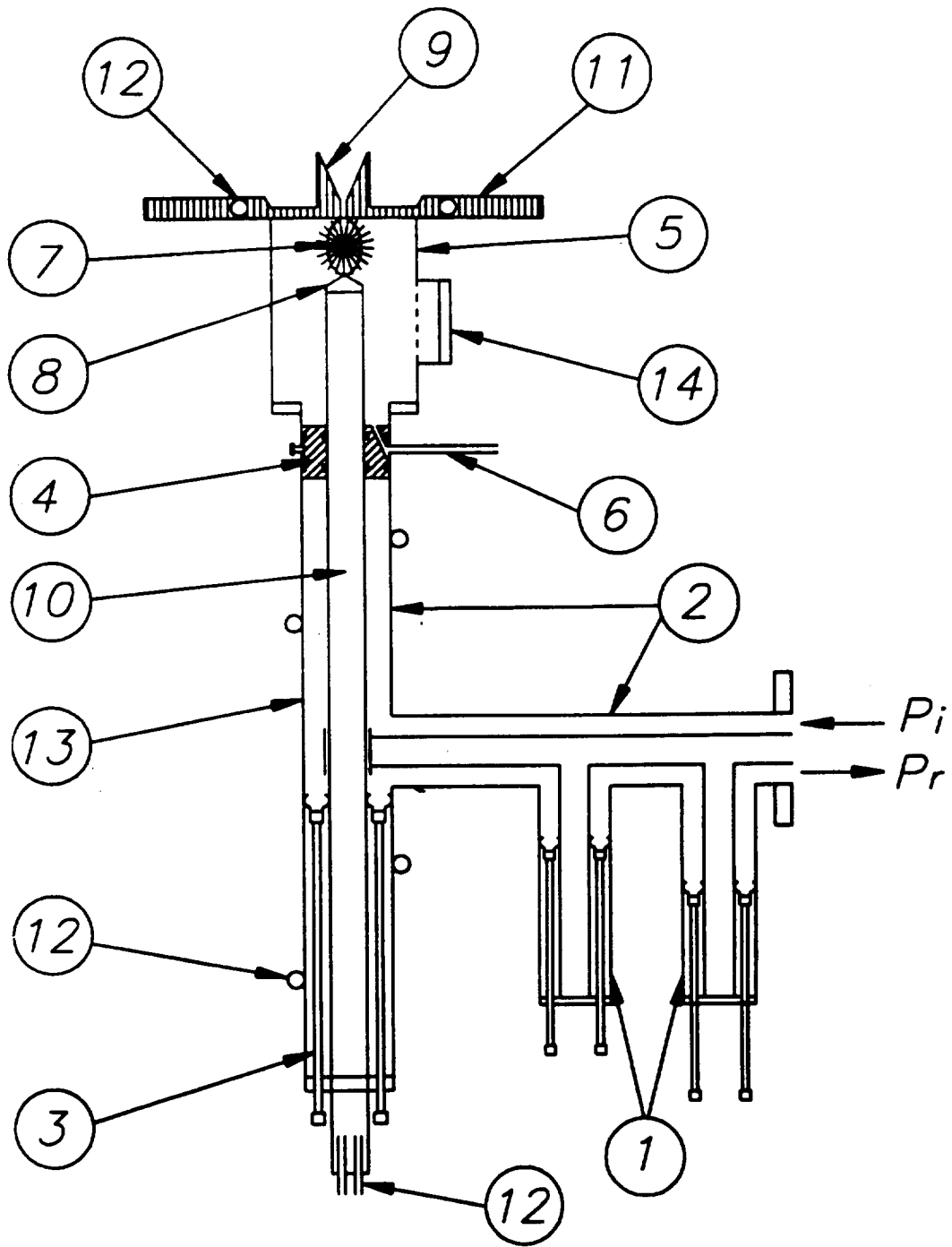



| Point | Gas Type       | Flow Rate<br>( $\frac{\mu\text{g}}{\text{s}} \times 10^{-6}$ ) | Discharge Pressure<br>(mmHg) | Nozzle Size<br>(mm) | Discharge Length<br>(cm) | Power<br>(Watts) |
|-------|----------------|--|------------------------------|---------------------|--------------------------|------------------|
| ①     | He             | 20.7   | 1260-1950                    | 0.635               | 2.22-2.86                | 235-868          |
| ②     | N <sub>2</sub> | 62.5   | 1660-2050                    | 0.635               | 2.22-3.18                | 315-787          |
| ③     | H <sub>2</sub> | 4.47   | 404-500                      | 0.635               | 2.20                     | 393-945          |
| ④     | He             | 29.7   | 702-1025                     | 1.02                | 2.22-2.53                | 314-946          |
| ⑤     | He             | 38.6   | 940-1295                     | 1.02                | 2.22                     | 314-869          |
| ⑥     | N <sub>2</sub> | 104  | 1020-1400                    | 1.02                | 3.17-3.64                | 315-788          |
| ⑦     | N <sub>2</sub> | 146  | 1372-1888                    | 1.02                | 2.22-4.12                | 394-791          |