

EMM/...

*FINAL
IN ORDER*

Final Report

submitted to

NATIONAL AERONAUTICS AND SPACE ADMINISTRATION
GEORGE C. MARSHALL SPACE FLIGHT CENTER, ALABAMA 35812

August 31, 1994

for Contract NAS8-38609

Delivery Order 112

entitled

Phase A Design Study of Microgravity Fluoride Fiber Puller

by

Gary L. Workman Ph. D.
Principal Investigator

Guy A. Smith
Senior Research Associate

Susan Kosten
Research Associate

Materials Processing Laboratory
Center for Automation and Robotics
University of Alabama in Huntsville
Huntsville, Alabama 35899

(NASA-CR-196513) PHASE A DESIGN
STUDY OF MICROGRAVITY FLUORIDE
FIBER PULLER Final Report (Alabama
Univ.) 60 p

N95-12752

Unclass

*** TABLE OF CONTENTS ***

LIST OF EXHIBITS iii

LIST OF ACRONYMS iv

1.0 INTRODUCTION 1

2.0 BACKGROUND 3

3.0 INFRARED FIBER EXPERIMENT OBJECTIVES 11

4.0 EXPERIMENTAL APPROACH 12

 4.1 Fiber Materials Selection

 4.2 Preform Processing Facility

 4.3 Fiber Pulling Facility

5.0 FLIGHT OPPORTUNITIES 14

 5.1 PPF and FPA Constraints

 5.2 Payload Carriers

 5.3 Mission Parameters

 5.4 Mission Duration

6.0 Orbital ZBLAN Processing Facility System Design 16

 6.0.1 Options for the Preform Processing Facility

 6.1 ZBLAN Preform Processing Facility 18

 6.1.1 Heater System

 6.1.2 Quench Block System

 6.2 ZBLAN Glass Fiber Pulling Facility 22

 6.2.1 Heater System

 6.2.2 Fiber Drawing System

 6.2.3 Fiber Coating System

 6.2.4 Containment Housing

 6.3 Data Acquisition and Control System 27

 6.3.1 Preform Processing Facility DACS

 6.3.2 Glass Fiber Pulling Facility DACS

6.4	Power and Weight Specifications	33
6.4.1	Power Budget	
6.4.2	Weight Budget	
6.5	Ground Support Equipment	35
6.6	Design Guidelines	35
6.6.1	Documentation	
6.6.1.1	Reference Documents	
6.6.2	Electrical Requirements	
6.6.2.1	Electromagnetic Interference (EMI)	
6.6.3	Material Selection and Process Control	
6.6.4	Hardware Life Requirements	
6.6.5	Environmental Design Requirements	
6.6.5.1	Ground Handling Environments	
7.0	FLIGHT EXPERIMENT	41
7.1	Baseline Mission Objectives	
7.2	Baseline Mission Timeline	
7.2.1	Pre-Launch and Launch Operations	
7.2.2	Orbital Operations	
7.2.3	Sample Retrieval and Analysis	
8.0	DEVELOPMENT PHASE IMPLEMENTATION PLAN	43
8.1	Schedule	
8.1.1	Phase I	
8.1.1.1	Hardware development	
8.1.1.2	Mission Planning Support Activities	
8.1.2	Phase II	
8.1.3	Phase III	
8.2	Cost Analysis	
9.0	SUMMARY	50
	REFERENCES	51

*** LIST OF EXHIBITS ***

Exhibit Number	Title	Page
1	Phase diagram of typical HMFG system.	4
2	Comparison of theoretical attenuation for HMFG with silica fibers.	4
3	Typical formulations used for HMFG optical fibers.	5
4	Video Photograph of high-g drawn E-glass Fiber	7
5	Video Photograph of low-g drawn E-glass Fiber	8
6	Results of Reduced Gravity on ZBLAN Fiber	9
7	Comparison of Effect of Gravity for Transparent ZBLAN Fiber	10
8	Top view of the PPF	19
9	PPF heater/quench block subsystem	20
10	Top view of the FPA	24
11	FPA heater/fiber initiator subsystem	25
12	DACS Functional Description for PPF.	28
13	PPF DACS flow diagram	29
14	DACS Functional Description for FPA.	30
15	FPA DACS flow diagram	32
16	Power Profile Concept for the PPF	34
17	Power Profile Concept for the FPA	34
18	PPF/FPA Summary Schedule	44
19	PPF/FPA Mission Planning Support Activities	48
20	PPF/FPA Cost Estimate	49

***** LIST OF ACRONYMS *****

A/D	- Analog to Digital
ADP	- Acceptance Data Package
ARR	- Acceptance / Readiness Review
ASTM	- American Society of Testing and Materials
BGG	- Barium Gallium Germanium
CAD	- Computer Aided Design
CDR	- Critical Design Review
CG	- Center of Gravity
CIR	- Cargo Integration Review
COQ	- Certification of Qualification
CSAR	- Canadian Space Application Rocket
DACS	- Data Acquisition and Control System
EMI	- Electromagnetic Interference
FAT	- First Article Test
FOR	- Flight Operations Review
FPA	- Fiber Pulling Apparatus
FRR	- Flight Readiness Review
GSE	- Ground Support Equipment
HMFG	- Heavy Metal Fluoride Glass
ICD	- Interface Control Document
IR	- Infrared
IFS	- Infrared Fiber Systems, Inc.
JSC	- Johnson Space Center
KSC	- Kennedy Space Center
MSFC	- Marshall Space Flight Center
NASA	- National Aeronautics and Space Administration
NHB	- NASA Handbook
PDR	- Preliminary Design Review

PGSC	- Payload and General Support Computer
PIP	- Payload Integration Plan
PPF	- Preform Processing Facility
PRR	- Payload Readiness Review
ppm	- parts per million
RAM	- Random Access Memory
SDP	- Safety Data Package
SPF	- Single Point Failure
SRR	- System Requirements Review
STS	- Space Transportation System
TBD	- To be determined
TDP	- Technical Data Package
UAH	- University of Alabama in Huntsville
VDC	- Volts of Direct Current
ZBL	- Glass material composed of fluorides of zirconium, barium and lanthanum
ZBLA	- Glass material composed of fluorides of zirconium, barium, lanthanum and aluminum
ZBLAN	- Glass material composed of fluorides of zirconium, barium, lanthanum, aluminum and sodium

1.0 INTRODUCTION

The fiber optics industry has grown into a multi-billion marketplace which will continue to grow into the 21st century.[1-5] Optical fiber communications is currently dominated by silica glass technology. Successful efforts to improve upon the low loss transmission characteristics of silica fibers has propelled the technology into the forefront of the communications industry. However, reaching the theoretical transmission capability of silica fiber through improved processing has still left a few application areas in which other fiber systems can provide an influential role due to specific characteristics of high theoretical transmission in the 2 - 3 micron wavelength region.

One of the other major materials used for optical fibers is the systems based upon heavy metal fluoride glass (HMFG). Commercial interest is driven primarily by the potential for low loss repeaterless infrared fibers. An example of the major communications marketplace which would benefit from the long distance repeaterless capability of infrared fibers is the submarine cables which link the continents.[5]

When considering commercial interests, optical fiber systems provide a healthy industrial position which continues to expand.[1-6] Major investments in the systems used for optical fiber communications have continued to increase each year and are predicted to continue well into the next century. Estimates of 8.5% compounded annually are predicted through 1999 for the North American market and 11% world-wide. The growth for the optical fiber cable itself is expected to continue between 44 and 50 per cent of the optical fiber communications budget through 1999.

The total budget in 1999 world-wide is expected to be in the neighborhood of \$9 billion.[3]

Another survey predicts that long haul telecommunications represents 15% of a world-wide fiber optics market in 1998.[4] The actual amount allotted to cable was not specified. However, another market research had predicted that the cable costs alone represents more than 50% of the total budget each year through 1998.[2]

A newly emerging activity is the commercial development of doped optical fibers which can be pumped by laser diodes to provide amplification of the communication signals.[6] This technology is newly emerging and will be developed for commercial interests in the United States by Galileo Electro-optical Incorporated in Sturbridge, MA on a license from British Telecom. Long repeaterless communication links provide the biggest stimulus for this technology.

As an example of the of the revenues involved in the optical fiber communications industry, the current trade journal lists that for the fiscal years, 1991 - 1994, 185 separate undersea links were established. In addition, another 105 links are planned through 1998. The distribution of revenues involved in the undersea installations is roughly \$8.5 billion through 1993 and another \$13 billion planned through 1998. A large portion of the future activity (34%) is planned for Southeast Asia and the Pacific Region. Other examples of the commercial utility of optical fiber networks is given in a recent scientific symposium in which the outlook for HMFG infrared fibers was determined to be very bright.[7]

Another area of interest lies in the use of fiber optics for laser surgery delivery systems, in which an optimal match between laser wavelength and fiber transmission characteristics occurs. For precise removal of tissue during surgery, research has shown that a wavelength in the 2.5 - 3.0 microns performs best. Experience with the combination of a pulsed Er:Yag laser (2.9 microns) delivered through a ZBLAN fiber has shown that this combination allows the removal of both fibrous and heavy calcified arterial plaque with little or no signs of thermal damage.[8] The 2.9 micron radiation corresponds quite closely with maximum tissue absorption (about 20 times greater than the 10.6 radiation from carbon dioxide lasers) and consequently allows very small penetration depth and precise tissue removal with no charring. This activity has proven to be of commercial value to small entrepreneurial companies such as Infrared Fiber Systems Inc. in Silver Spring, MD.

Process improvements which can enable heavy metal fluoride fibers to meet the their theoretical capabilities will provide the communication and medical industries with very desirable technology and products. Current manufacturers are very small and growth would be expected, as well as technology spin-offs to other manufacturers. It is the goal of space based experiments to provide much higher quality fiber with near theoretical transmission capability for development of commercial markets in the United States.

2.0 BACKGROUND

The initial research into the use of multicomponent fluorides based on ZrF_4 chemistry led to the 1974 discovery of an amorphous product by Professor M. Poulain and his co-workers at the University of Rennes in France.[9] The remarkable feature of this work was that all the starting materials were crystalline and with the proper stoichiometry, amorphous glasses could be produced. From this work, and others beginning to take an interest in the United States, the chemistry of the heavy metal fluoride glasses began to take shape.

An example of the HMFG chemistry is shown in Exhibit 1 below. The phase diagram for the ZrF_4 - BaF_2 - LaF_3 (or ZBL glass) shows a region in which stable glass and a region of unstable glass devitrifies into crystalline material. An understanding of this chemistry led to the conclusion that ZF_4 was the glass former, BaF_2 was the modifier and a small amount of LaF_3 helped to decrease the devitrification rate was called a stabilizer. Other HMFG compositions were tried in the 1980's but none were as prolific in the research laboratories in both Europe and the United States as the ZBL systems. Further research evolved into the material of interest today, ZBLAN, in which AlF_3 and NaF are added to improve the glass forming capabilities of the final product. Current industrial practices uses hafnium for the cladding and consequently HfF_4 has also become an important ingredient in the overall chemistry.

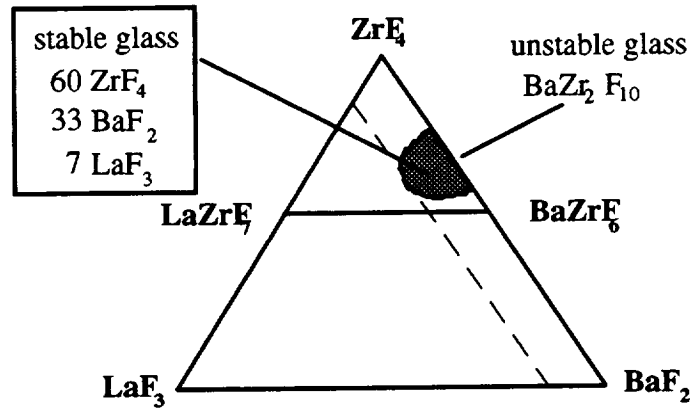

Exhibit 1. Phase diagram of typical HMFG system.

The primary focus on HMFG as an optical fiber material, in spite of its early shortcomings in reliable glass forming due to devitrification, was the theoretical prediction of low-loss of 0.001 dB/km at 3 microns as compared to silica (0.2 km/dB at 1.55 microns). The original theoretical work which indicated that the HMFG materials would have very good transmission characteristics was published by S. Shibata, et. al. and extended in more depth by the work of Lines, however equations defined in his work show the following result in Exhibit 2.[11]

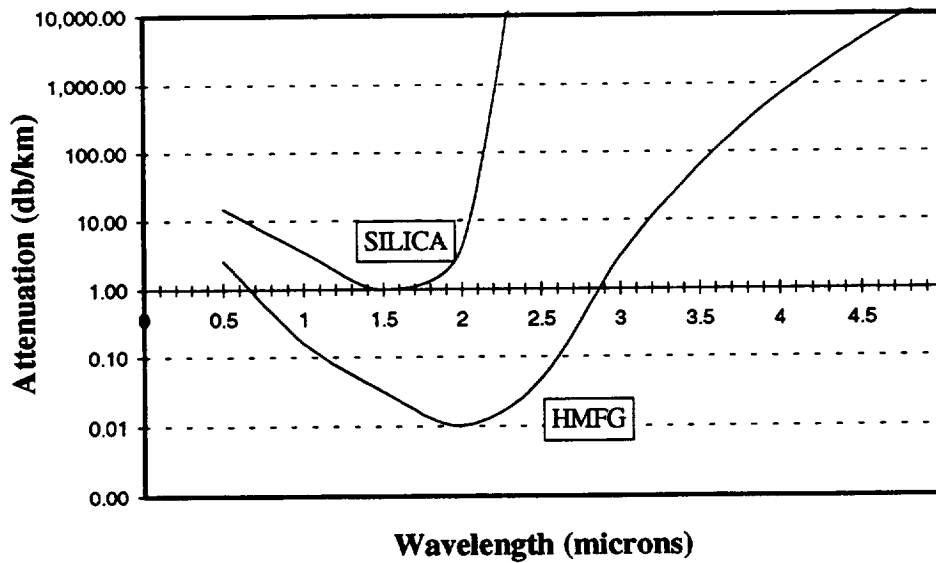

Exhibit 2. Comparison of theoretical attenuation for HMFG with average grade silica fibers.

The lower loss potential for long distance repeaterless fiber optic cable systems (under-sea) and special purposes (medical laser surgery) promised a potential market of a high magnitude. For this reason many industrial and government laboratories world-wide began research in the HMFG including, Nippon Telegraph Telephone, British Telecom Labs, Naval Research Labs, Rome Air Development Center, ATT Bell Labs, Furukawa Industries, Corning Glass, Centre National d'Etudes des Telecommunications, and many more.

A number of formulations have been used to fabricate optical fiber devices in the 1980's and 90's. The use of zirconium fluoride as the primary constituent with fluorides of other metals such as barium, aluminum, sodium, lanthanum, etc. has led to general fiber compositions such as illustrated in Exhibit 3 below. The acronym used to describe these materials is based upon the metallic elements used in the fiber.

Acronym	ZrF ₄	BaF ₂	LaF ₃	AlF ₃	NaF	T _g	T _x	T _c
ZBLAN20	53	19	5	3	20	263	384	405
ZBLAN8	55	30	3	4	8	295	381	401
ZBLA	60	30	3	5		312		384
ZB	65	35				295	352	365

Exhibit 3. Typical formulations used for HMFG optical fibers.[12]

The major difficulties in ZBLAN processing have been determined to be due to the development of microcrystallites during both preform casting and during draw.[13-16] A major improvement in both the transmission and strength of the fiber can be obtained through a fiber fabrication process in which the microcrystallite population is substantially reduced.

Several research activities in microgravity science have observed the decreasing tendency of crystallization while processing in the microgravity environment.[18,19,21] The rationale for this behavior has not been determined at this time and continues to be a concept requiring further research. In the meantime, the industrial uses for an improved ZBLAN fiber provides a need to obtain a microgravity processed material in order to provide a better product of both industry and medicine.

The methodology for fabricating HMFG fibers in the 1980's led to the use of a particularly well behaving glass in the ZBLAN category. Current formulation for a ZBLAN glass fiber consists of

the following exhibit.[19] The methodology for the rotational casting of preforms using hafnium fluoride as a cladding material was developed by Dr. Danh Tran while at the Naval Research Laboratories.[20] This fiber is a current product of IFS, Inc.

Z(H)BLAN fiber	ZrF ₄	BaF ₂	LaF ₃	AlF ₃	NaF	HfF ₄
core	53	20	4	3	20	0
cladding	39.7	18	4	3	22	13.3

Several experiments relating to space processing of ZBLAN type fibers have been attempted since the mid 1980's. The first attempt was by Doremus, who flew a ZBL composition on the Shuttle using a three axis acoustic levitator for containerless processing experiment.[19] The experiment malfunctioned and was never reflowed. A Canadian experiment flown on their T-33 aircraft was not totally successful in processing ZBLAN fibers due to poor thermal gradients in the furnace [21] and a subsequent flight on a CSAR failed due to extreme gravity levels encountered during reentry.

On the other hand several experiments which were performed by Dr. Dennis Tucker of MSFC and Mr. Guy Smith of the University of Alabama in Huntsville did successfully pull fibers on the KC-135 during the time frame of 1991 - 1994. The KC-135 experiments included a number of different materials, which were either drawn as fiber, or fibers which were heated just above the crystallization (T_x) process during the reduced gravity portion of the parabolic flights.[22-25] Several key observations from the KC-135 experiments support the concept that fiber drawing or preform processing in reduced gravity should be beneficial. During contract NAS8-38609 D.O. 19, both E-glass and BGG optical glass were drawn into continuous fibers during KC-135 flights. SVHS video was recorded while the fibers were being drawn during low and high gravity environments. The results of these flights demonstrate beyond any doubt that continuous optical fibers can be drawn in microgravity. Exhibits 4 and 5 show the different effects high and low gravity have during a drawing process on E-glass. At 0.01 g the fiber diameter was measured to be 100 micrometers while at 1.8 g's the diameter enlarged to 240 micrometers. The draw rate was held continuous at 30 cm/sec.

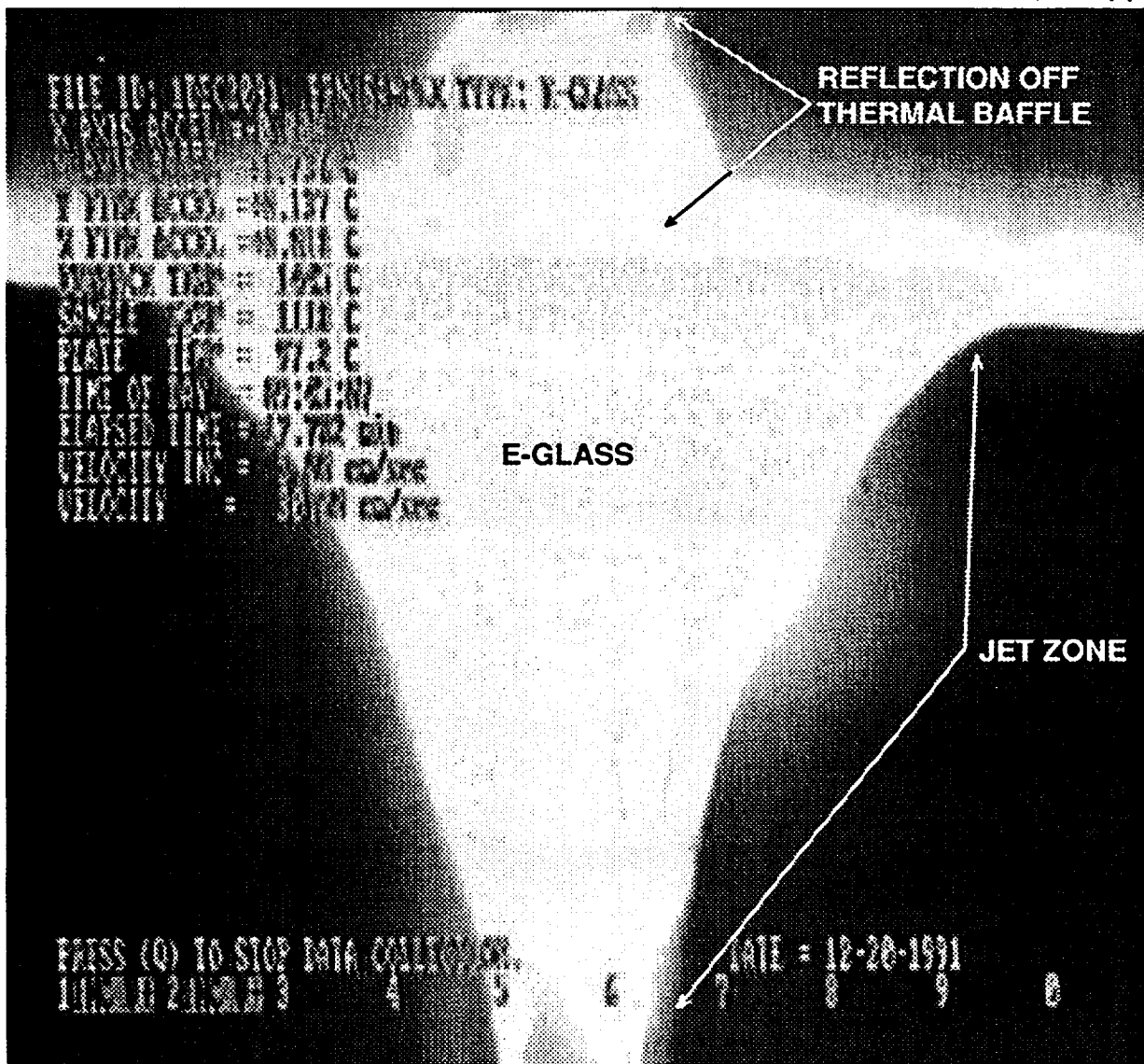

Exhibit 4: Video photograph of high-g drawn E-glass fiber

The run shown in Exhibit 4 was performed on December 20, 1991 during a high-g period on NASA's KC-135 using the Fiber Pulling Apparatus (FPA). This item of hardware was specifically built for use on the KC. The same run is shown a few seconds later in Exhibit 5 during the low-g period just following Exhibit 4. Transition of the jet zone shape occurs very quickly (within 1 second) in response to the changing gravity level. During this run a continuous fiber was drawn and spooled on a 6 inch diameter bobbin over the time period of several parabolas. At the top of the picture is an area denoted as a reflection. This is due to the polished surface of the thermal baffle causing a mirror image to be formed of the jet zone and fiber.

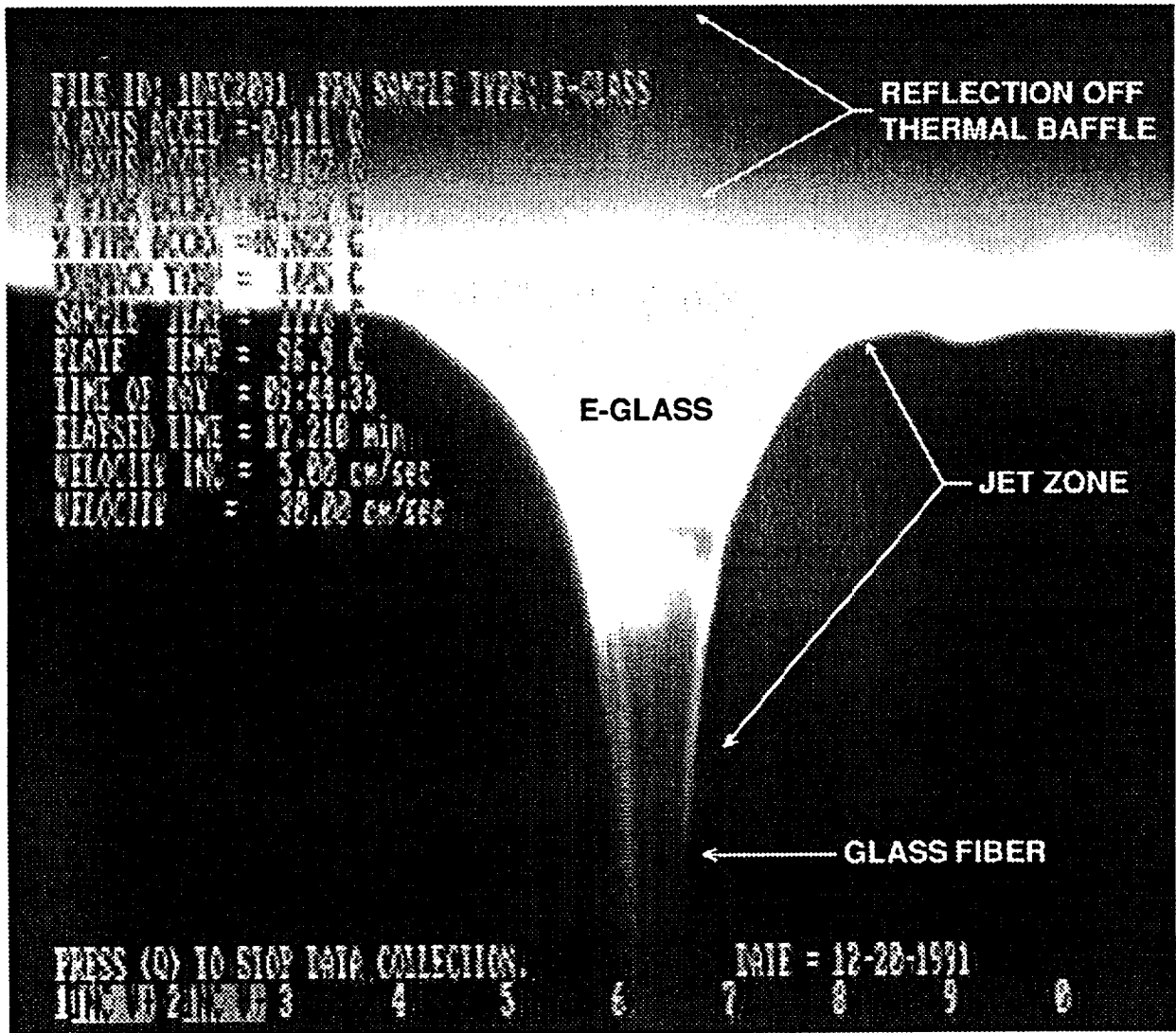

Exhibit 5: Video photograph of low-g drawn E-glass fiber.

The above photograph indicates how the jet zone "necks down" due to surface tension driven forces. These forces become dominant during the low-g period. This in turn results in a small fiber diameter being formed even though the heater temperature and draw rate was held constant. In order to produce a larger diameter fiber while in low-g either the temperature or draw rate would have to be lowered. On a subsequent flight in March of 1993 a BGG glass sample, supplied by the Naval Research Labs, was also drawn during multiple parabolas. It presented the same results in responding to the varying gravity levels.

Exhibits 6 and 7 contain photographs taken of ZBLAN fibers which were processed at 415° C for about 5 seconds and quenched rapidly using water spray during a recent KC-135 flight. The reduced gravity samples showed dramatically fewer crystallites than the high-g samples.

Exhibit 6. Results of Reduced Gravity on ZBLAN Fiber

a.) Specimen annealed in reduced gravity showed no microcrystallite formation. Surface features are due to contamination from quartz ampoule.

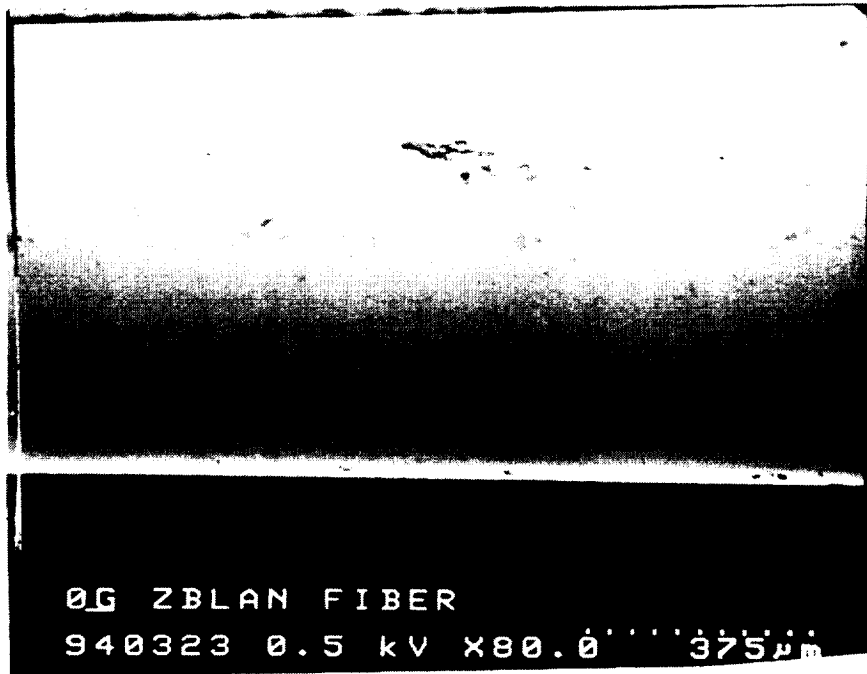

b.) Specimen annealed at 1 g showed regions of extreme microcrystallite formation.



Exhibit 7. Comparison of Effect of Gravity on Transparency of ZBLAN Fiber

- a.) Specimen annealed in reduced gravity shows very high transparency.

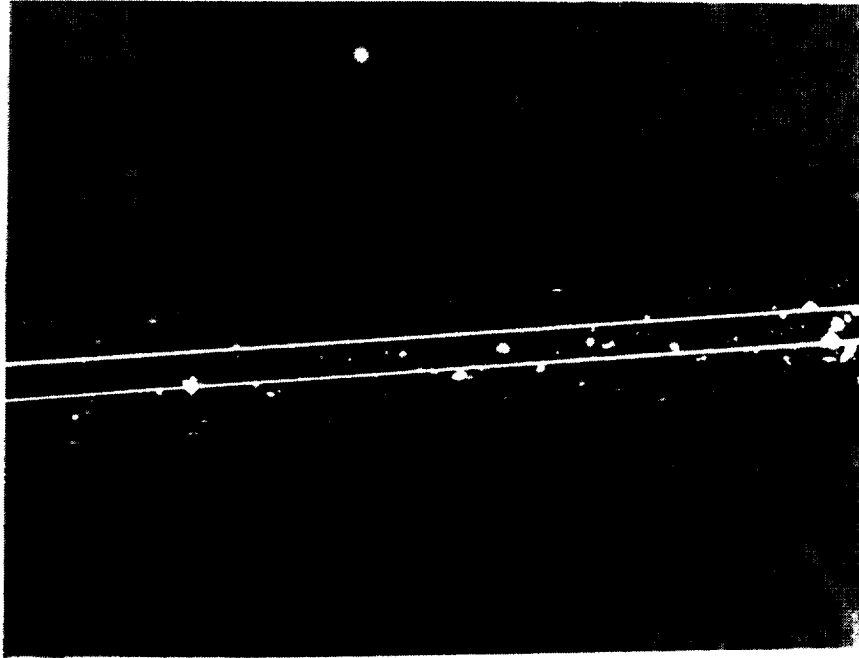

- b.) Specimen annealed in 1 g shows regions in which nucleation of microcrystallites were very prominent.



3.0 PREFORM PROCESSING AND FIBER PULLING MISSION OBJECTIVES

The objective for the Preform Processing Facility (PPF) and the Fiber Pulling Apparatus (FPA) is to process commercial grade HMFG optical fiber materials in space to demonstrate that microgravity processing can improve optical fiber materials by reducing microcrystallite formation. It is anticipated that a major benefit derived from microgravity processing of HMFG materials is to produce higher quality optical fiber, since most current concepts indicate that microcrystallite formation in either the preform or the fiber drawing stages, is detrimental to the resulting optical fiber. Consequently, the space experiment will be designed to sort out the benefits of space for fiber drawing by obtaining products from both processes, preform processing and fiber pulling.

The products returned from space will be analyzed by the participating firms who are actively doing business in providing such products in the marketplace, so that an accurate analysis of the benefits derived from the space processing are obtained. In the case of the preform processing, commercial benefits can be realized either through ground based drawing operations of a preform processed in space to provide commercial products for sale by the industrial partners or, as in the normal perspective for space processing, a level of knowledge about the preform preparation process can be obtained through space processing to allow further improvements to be attained in normal ground based processes. In the case of the optical fiber drawing process, it is not clear at this time that commercial end-products would be returned to earth from the space operations; especially when one considers the many kilometers of communications fibers that is required for undersea cables across the oceans of the world. However, specialty niches, such as medical surgery applications, may evolve once optical fiber products are available from space processing.

4.0 EXPERIMENTAL APPROACH

The objectives are attained through two distinct experiments, the first in which several commercial grade preforms are annealed at 800° C for 1 hour and returned to earth for analysis and processing into optical fibers. The analysis of the final product will demonstrate if microgravity processing can produce superior product by elimination of microcrystallites within the preform itself.

The second experiment will focus on the fiber drawing process itself. The fiber draw will utilize a preform processed in the first experiment, which will be devoid of microcrystallites. Hence no microcrystallites will be formed due to the two step microgravity processing. The fiber resulting from this experiment can be compared with the ground based fibers and the fibers which had previously been preform processed in space and drawn on the ground.

4.1 Fiber Materials Selection

In review of the processes which are currently of commercial interest, the ZBLAN optical fiber has become the most prevalent. Companies fabricating optical fibers from this composition include two US companies and one French corporation. The markets which are supplied by these organizations are currently the specialty fibers which fit a particular niche for specific purposes. For example medical surgery applications or wavelength compatibility other than what silica can deliver. The two US companies, IFS and Galileo have been approached to supply commercial grade preforms for space processing.

Z(H)BLAN fiber	ZrF ₄	BaF ₂	LaF ₃	AlF ₃	NaF	HfF ₄
core	53	20	4	3	20	
cladding	39.7	18	4	3	22	13.3

For fiber amplifier devices the core is normally doped with a small percentage of rare earth ions, such as praseodymium.[6]

4.2 Preform Processing Facility (PPF)

The preform processing facility can be performed very straight forwardly with several samples. The normal processing temperature of 800° C is sufficient to dissolve already nucleated clusters so that cooling down below the glass transition point will eliminate the formation of microcrystallites.

Upon return from the space, the samples will be distributed among the industrial partners, who will perform an optical scattering analysis on the preforms to determine if microcrystallite formation was reduced by the space processing. Each participant will then perform their normal drawing operation to obtain a fiber that had been annealed in space and drawn at 1 g. The resulting fiber will be characterized as an optical fiber to compare with traditionally drawn fibers.

4.3 Fiber Pulling Apparatus (FPA)

The fiber pulling experiment will duplicate the traditional fiber draw apparatus as currently performed by commercial entities such as IFS, Inc. The starting material for the preform will be already annealed from the earlier flight. Hence nucleation of microcrystallites is not expected to be carried over from the original casting operation and subsequently none are expected to be formed during the draw.

The fiber will consist of two cladding materials, the hafnium which provides the waveguide characteristics for the fiber and a UV curable acrylic to protect the fiber against abrasion and hydroscopic deterioration. The optical fiber is drawn, coated and spooled for convenient transportation back to the ground for distribution to the commercial partners.

5.0 FLIGHT OPPORTUNITIES

The PPF/FPA is a materials processing facility for the production of either preforms for preparing optical fibers or for the production of HMFG optical fibers. The access to a microgravity environment in order to reduce undesirable nucleation events in processed preforms or fibers is the reason for space flight. The flight hardware has been designed to accommodate either preform processing or fiber pulling of HMFG in order to obtain maximum value to the industrial benefits of the space processing.

5.1 PPF and FPA Constraints

The only constraints the PPF and FPA will place on the Orbiter is power and, to a minor extent, data utilities in the form of a VCR and possible real time video down link during the initial operation of the FPA. The crew member (Payload Specialist) will play the critical role in the operation of the FPA while the PPF will only require activation and perhaps occasional monitoring. While the PPF will require only minor interaction, the FPA on the other hand will require a major training effort on the ground and up to three hours of continuous involvement in the progress of the glass drawing process. In the event that real time video down link is possible during the operation of the FPA we on the ground will be able to assist the crew member if special situations ensue. With out the live video link this interaction with the crew member will not be possible and it will be up to him or her to know how to handle any circumstance that may arise.

5.2 Payload Carriers

The two facilities proposed at this time will be designed for flight on the Orbiter's Middeck since this is the easiest and most cost effective avenue to pursue at this time. Other options naturally include SpaceHab and SpaceLab, however due to the relatively infrequent flights of these carriers this mode is not preferred. The only other option before Space Station is to use a Hitchhiker-g although this again would be more costly and take longer to complete. Later, the Space Station will provide an ideal platform for the processing of both preforms and fibers. At that time, a second housing and controls can be fabricated in order to be able to perform both activities with minimum interference.

5.3 Mission Parameters

The PPF/FPA will not be limited by orbital or attitude parameters. Scheduling of the activities related to materials processing requirements for both PPF and FPA will be optimal during reduced crew activity but not required. The PPF does not require the constant attention of the crew, however, for all samples to be processed several hours are required. This activity may be more optimal during crew sleep time since it does not require constant attention. The FPA does require a considerable amount of crew time to initiate the draw and monitor the process, but the total time is less than three hours and will not be impacted by other operations within the Orbiter.

5.4 Mission Duration

Each space manufacturing operation can be performed in less than eight hours, with the FPA operation requiring the least amount of time. One Shuttle mission, of any timeline, can be used to process the HMFG samples required.

6.0 ORBITAL ZBLAN PROCESSING FACILITY SYSTEM DESIGN

The successful completion of the mission goals for this project require two separate and different flight hardware systems to be developed. Each one will be flown separately thus requiring two Shuttle flights. This methodology is in the interests of hardware and logistics simplicity. This configuration requires no sample change out during either flight and thus greatly reducing the hardware requirements and safety hazards associated with such operations. By keeping the hardware simple and using off-the-shelf components where possible it is believed that this will provide the most cost effective means of bread boarding a potential commercial application of space. All designs will be based on the past fifteen years of development and fabrication experience with furnace systems and in particular the Fiber Pulling and Annealing Furnace systems built and recently flown several times on NASA's KC-135 and funded through contracts NAS8-36955 D.O.113, NAS8-38609 D.O. 19 and 102.[22-25] The successful results and experience gained in performing those experiments aboard the KC-135 clearly indicates that the next step is to process ZBLAN glass in space.

In the first step to processing ZBLAN glass on the Orbiter, the Preform Processing Facility (PPF) will allow the purification of glass preforms in a manner as to remove residual crystallites from the preform. To accomplish this, a small heater system will re-melt the preform for a period of 30 minutes at 800°C. At the end of the time period it will be rapidly cooled by moving the preform from the heater to a copper block heat sink. In the present concept four to perhaps six heater assemblies and necessary support hardware will be contained within a standard Middeck locker. Two complete flight systems will be fabricated and flown simultaneously. Therefore a total of up to twelve samples could be processed in one flight. Upon the return of the processed preforms, some will be saved for a subsequent flight of drawing optical fibers in microgravity and the rest will be drawn into optical fibers using conventional ground based equipment at Infrared Fiber Systems, Inc. and Galileo Electro-Optics Corporation. Orbiter crew involvement with the operation of this system will be low in that this system lends itself well to automation.

On a subsequent Shuttle flight the ZBLAN Fiber Pulling Apparatus (FPA) will be flown to actually draw optical glass fibers from one of the previously flown and process ZBLAN preforms.

Ground based production runs have shown that several hundred meters of fiber can be produced from a typical preform. Again two identical hardware systems will be flown during the flight. Preliminary designs indicate that the standard Middeck locker will be too small to accommodate the system and therefore a custom built locker will be required. The payload will be attached to two Payload Mounting Panels. Crew involvement with this system will be moderate for reasons to be discussed later.

In justifying why two identical sets of hardware systems should be flown it can be stated that this simply increases the odds of success by the inherence of a backup. By keeping the systems design simple, the cost of fabricating two sets of hardware is well within reason. Additionally, by keeping them small they are well suited for any of the three avionics bay areas in the Orbiter's Middeck area.

6.0.1 Options for the Preform Processing Facility

At this stage of planning there are basically two routes to take in terms of developing the PPF system. One scenario involves fabricating the PPF to fit within a standard Middeck locker. This scenario is preferred since the greatest possible number of flight opportunities exist for standard size lockers. The second scenario will involve fabricating the PPF to fit within the custom built containment housing of the Fiber Pulling Apparatus. This scenario is the most cost effective; however, it may result in fewer flight opportunities. It is assumed at this point in time that special flight hardware that requires two Payload Mounting Panels creates a greater impact on manifesting. It is also possible to fabricate the PPF in a way to be interchangeable with either of the two flight carriers. Further detailed design development and a prediction from NASA on the flight opportunities for Middeck will determine the best path to take.

6.1 ZBLAN Preform Processing Facility (PPF)

The PPF is a small and relatively simple apparatus which is designed to re-melt the ground based manufactured ZBLAN glass preform and in so doing allow any residual crystallites to dissolve back into the ZBLAN liquidus. Exhibit 8 provides a top view of the proposed facility. In this view there are four identical heater assemblies. Each assembly consists of an heater which will operate at 800°C, a copper quench block to quickly resolidify the preform and a translation mechanism to move the preform to and from the quench block. Each preform is contained within a sealed Platinum/5% Rhodium alloy cartridge which will maintain the shape of the preform while it is in a molten state. The cartridge is sealed and thus will also act as the first level of containment. A typical ZBLAN glass preform has the dimensions of 1.5 cm in diameter and 11 cm long as supplied by Infrared Fiber Systems, Inc.

6.1.1 Heater System

The preform heater will essentially be of a typical tube heater design 5 inches long and 3.5 inches in diameter. The heater core design will be based on the past 13 years of in house experience with specially wound heaters which provide good isothermal distribution of heat throughout the length of the preform. Exhibit 9 provides a cross sectional view of the heater. Careful multilayer insulation techniques will allow the sample cartridge to reach 800°C with less than a 70 watt input. Since each heater will only be on for a total period of less than two hours and with a sufficient delay built in the software to initiate the next heater sequence, active cooling to control the facilities interior temperature is not considered necessary at this time.

The sample cartridge will be held in place at the end of a small diameter stainless steel rod which is connected to the linear actuator. The actuator will be located behind the copper quench block. The rod of the actuator will pass through the quench block and extend into the heater. The sample cartridge will be located the end of the rod. Upon completing the 30 minute 800°C soak period the sample cartridge will move from the heater into the quench block. Here radiative cooling of the sample will provide a quench fast enough to prevent nucleation of crystallites. While the sample is located within the quench block, the heater will be allowed to cool by natural means to 300°C. Upon reaching a stable heater temperature, the sample will then be placed

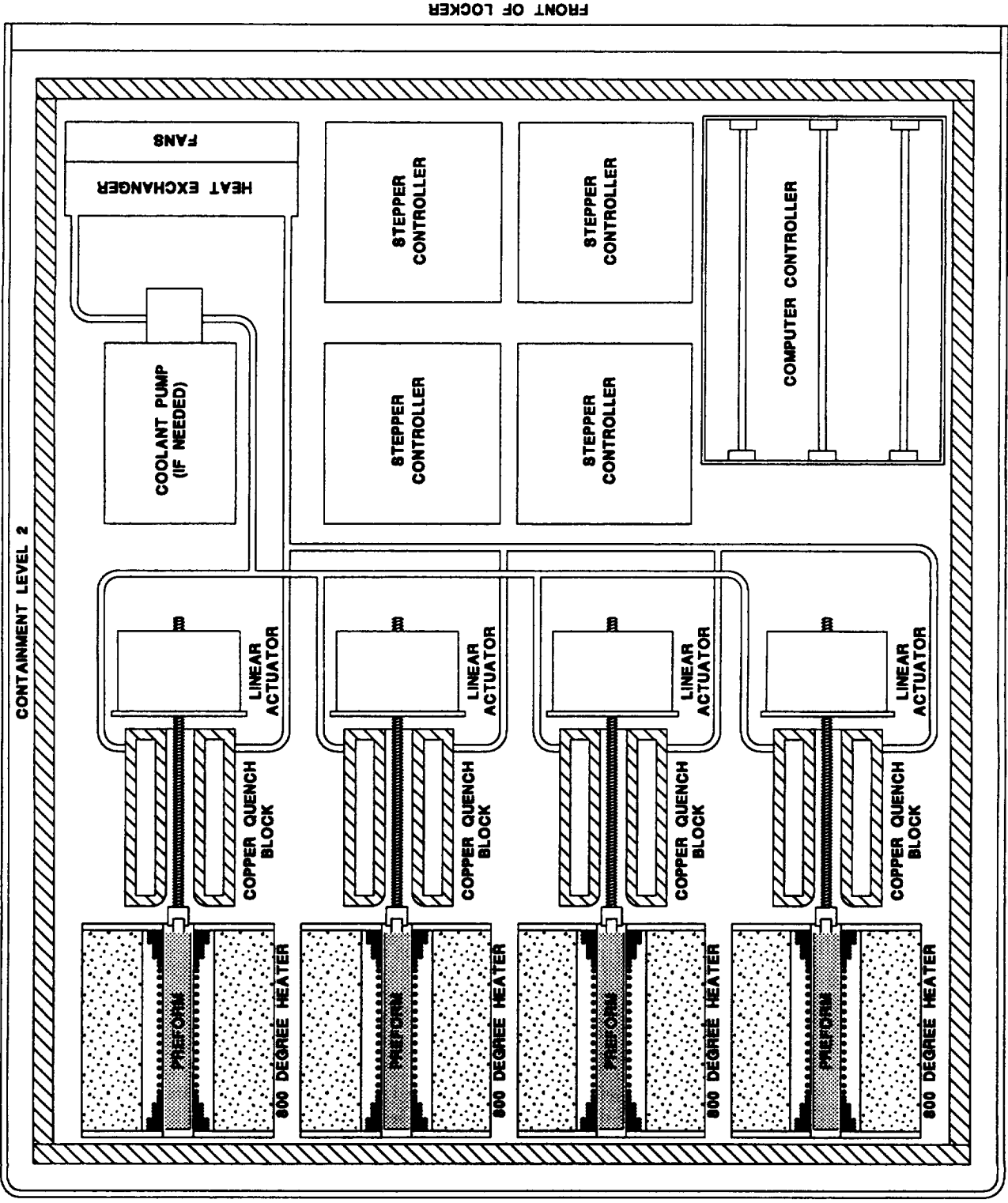

3" 2" 1" 0"
SCALE

Exhibit 8: Top view of the PPF

SOME ITEMS ARE SHOWN IN CROSS
SECTIONAL VIEW FOR DETAIL.

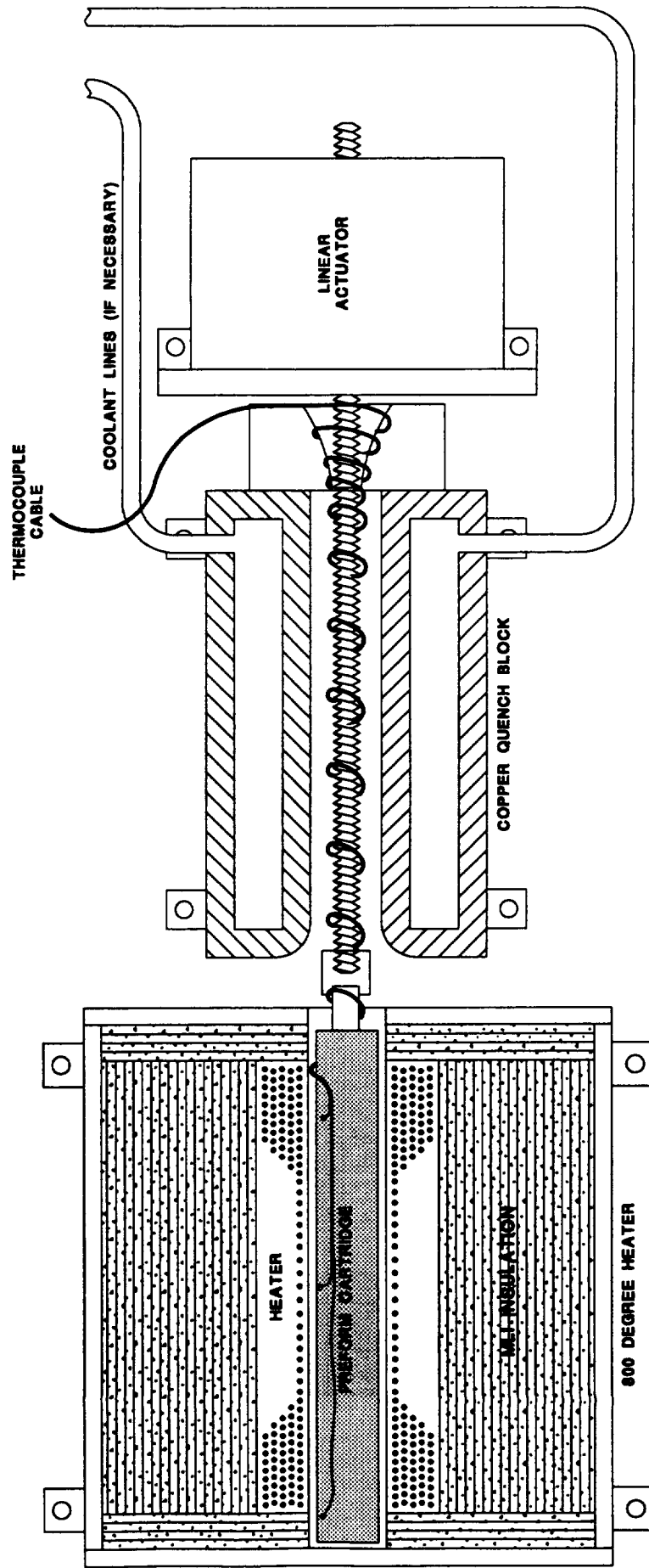

Exhibit 9: PPF heater/quench block subsystem

back into the heater. At this stage the sample will be annealed for 60 minutes to remove any residual stresses which could cause the reprocessed preform to shatter due to re-entry, landing, or post landing vibrations. At the end of the 60 minutes the heater and sample will then be ramped down to ambient at 2°C/minute.

While it may seem that this would be a perfect application of a sample carousel and an automated sample change out mechanism for multiple samples it is believed that this only reduces reliability. Past experience with automated sample change out systems on the Orbiter have not demonstrated 100% success rates. A multiple heater method is less complicated in that there are fewer moving parts, the control software is simpler, and there would be fewer actuators (steppers, solenoids, etc.) resulting in less power consumption. Built in redundancy means that if for some reason one heater/quench block assembly should fail then the software could skip to the next assembly and only one sample would be lost. The development and testing time required for both the hardware and software is also much simpler with a multiple heater design.

Instrumentation of the sample and heater will include a total of seven thermocouples, three attached to the exterior surface of the Platinum/5% Rhodium cartridge, two to provide a control signal to the temperature controller and two located on the outside of the heater canister. The quench block will also have two thermocouples located to monitor its temperature. All thermocouples used will be either type K or T depending upon the maximum temperature to monitor. A position sensor will provide a positive feedback of the sample cartridge position in the assembly in addition to microswitches. For safety reasons the heater will incorporate triple redundancy in preventing thermal overheating or runaway. This will include the temperature controller itself acting as the primary control, a software override control of the power to the heater core based on separate thermocouple feedbacks, and for the third level a mechanical thermal self-resetting power switch located on the heater canister wall. This same methodology for thermal safety will be applied to the Fiber Pulling Apparatus as well.

6.1.2 Quench Block System

The method to rapidly cool the 800°C preform involves removing the sample cartridge from the heater and immediately locating it inside a copper quench block. A linear actuator composed of a stepping motor and screw drive shaft connected to the sample cartridge will comprise the translator mechanism. Cooling will be accomplished by radiative and conductive thermal transfer to the copper. At this point it has not been determined if the copper block will need to be actively cooled. Preliminary thermal modeling indicates that it may be required to adequately cool the sample and prevent excessive heat build up inside the housing. If this were to be the case then a cooling system comprised of a water pump and heat exchanger could be readily implemented. The copper quench block design will be modified to allow coolant flow through the block. A liquid to air heat exchanger will dump approximately 30 watts of heat into the Middeck cabin air on an intermittent time basis.

6.2 ZBLAN Fiber Pulling Apparatus (FPA)

Using one of the ZBLAN glass preforms processed in the PPF during a previous flight, the FPA system will be used to actually draw an optical glass fiber. It is planned to draw several hundred meters of fiber. A custom built containment housing will be needed to provide the additional space, due to the distances required to draw a fiber. In this system, only one heater will be housed and only one sample will be processed into fiber. In order to better guarantee mission success it has been suggested to build and fly two identical systems due to uncertainty in the fiber initiation stage. The action of starting a glass fiber will be highly crew interactive. Flying two units at the same time will require a total of four Payload Mounting Panels. There are no requirements as to where or which avionic bays the systems should be mounted in.

6.2.1 Heater System

The glass drawing heater in many regards will be much simpler than those used in the PPF. When drawing fiber from a glass preform only the very tip of the preform is actually heated to soften the glass. In this way, the process of drawing a fiber can be considered “containerless.” For ZBLAN a temperature of 350° or lower is all that is required to soften the glass. Drehman recommends

not exceeding 350°C to help limit nuclei formation.[14] Exhibit 11 provides a cross sectional view of the heater and fiber initiator subsystem. Due to the low temperatures required for this particular heater, special or exotic techniques in heater design are not required. Preliminary thermal modeling indicates that passive cooling only is sufficient to prevent excessive heat build up.

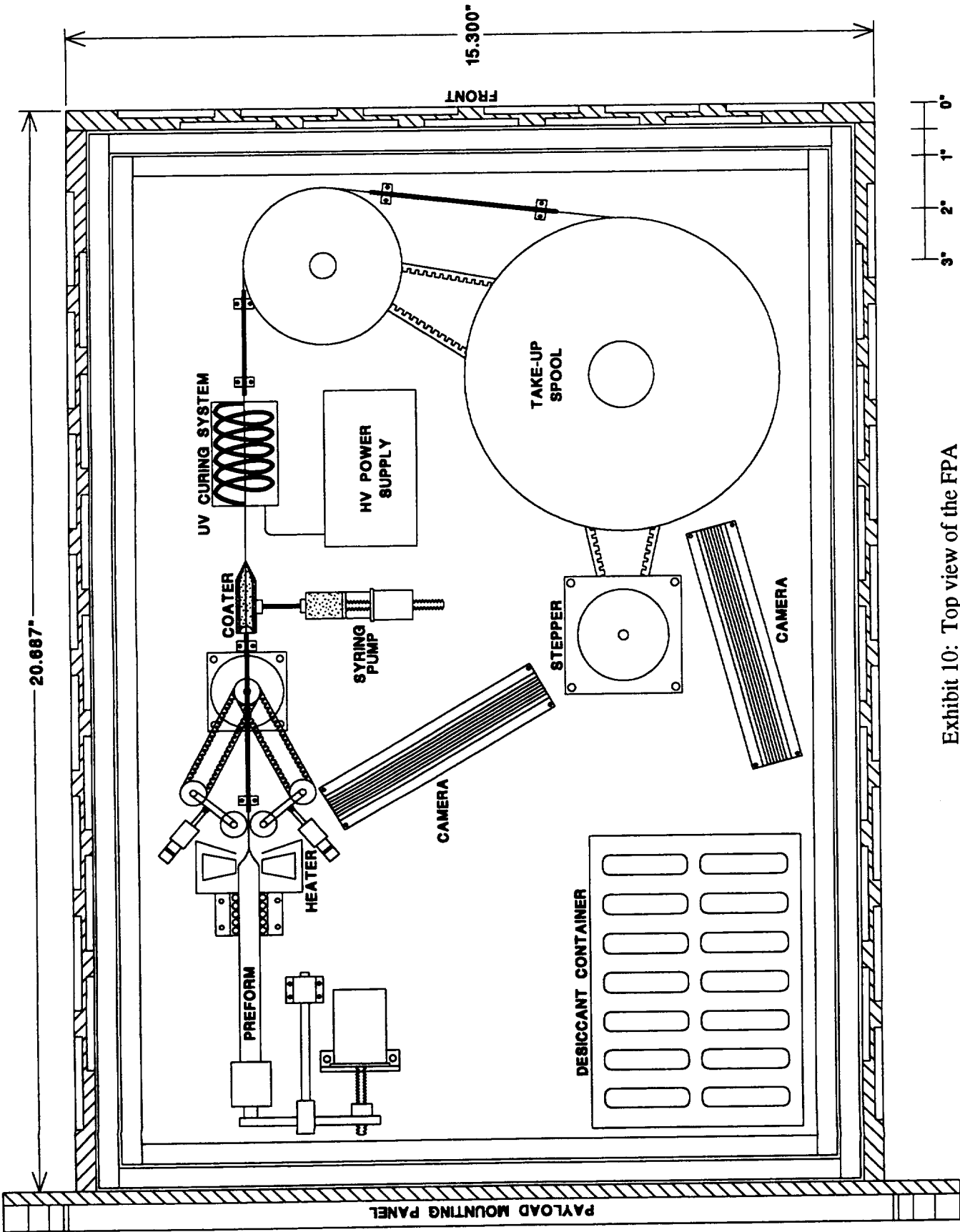
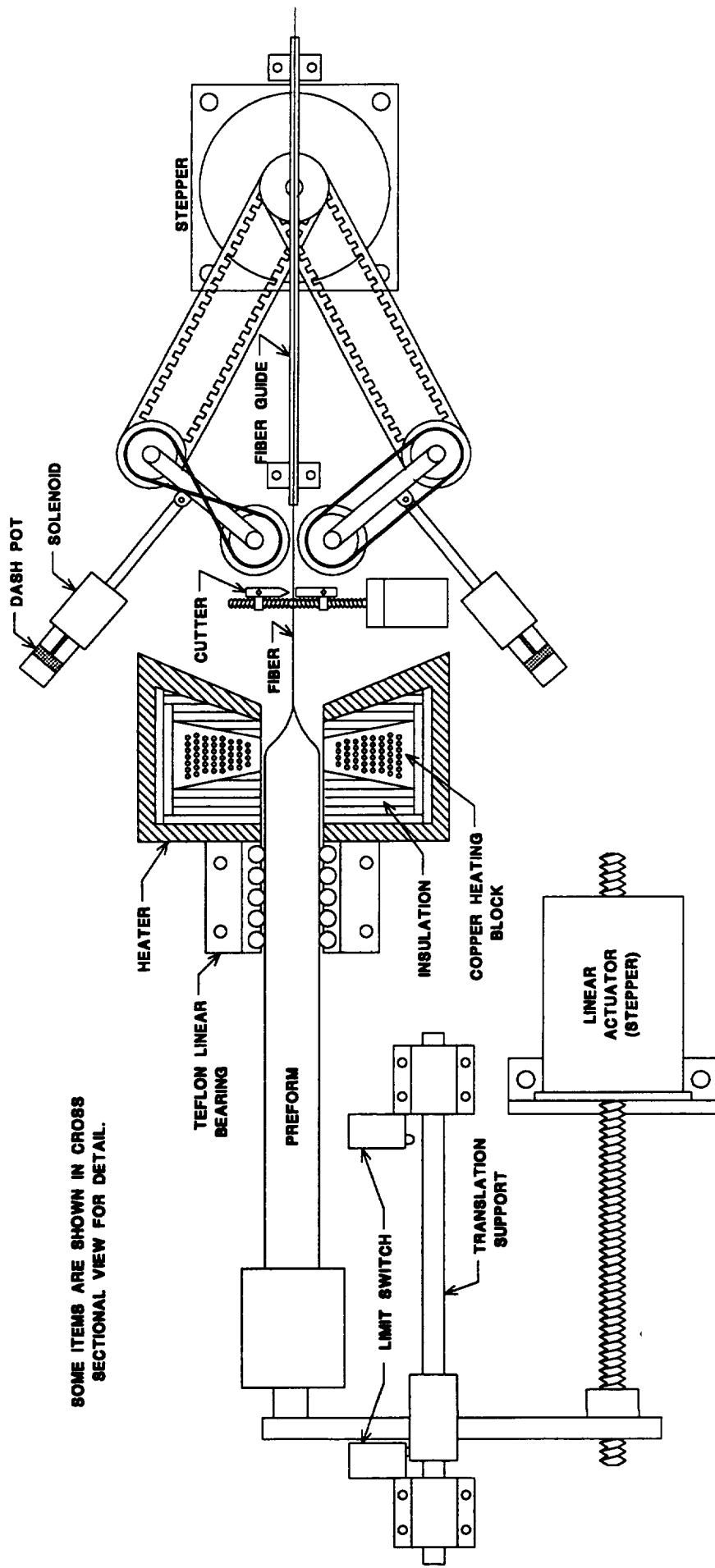

Exhibit 10: Top view of the FPA



SOME ITEMS ARE SHOWN IN CROSS SECTIONAL VIEW FOR DETAIL.

Exhibit 11: FPA heater/fiber initiator subsystem

6.2.2 Fiber Drawing System

The most critical part of this system is the mechanism to initiate the fiber draw from the preform. On Earth, gravity is used to form a fiber by allowing a the softened glass to slowly fall from the preform tip and thus due to the viscosity and surface tension properties, a fiber is formed.

However in space this method for starting a fiber is obviously not possible. During research conducted on the KC-135 we were able to use a platinum wire sting to initiate a glass fiber. It was quickly learned that this process was not easy and required considerable practice.

With this system a pair of mechanical stepper driven rollers will be used to position and drive the sting into the soften glass. The crew members will control the stepper for positioning of the stinger. Sting and fiber guides will maintain the proper alignment for the string during insertion and withdrawal/drawing actions. A small shear type cutter will also be in the line of fiber travel. Its function is to assist in recovering from a failed attempt in inserting the stinger into the preform. Once the glass fiber has been started the feed rollers will be retracted away to prevent contact with the fiber. This will help reduce mechanical abrasion on the fiber which sometimes can induce a fracture in the glass.

At the end of the fiber travel will be a 6 inch diameter take up spool under control of a stepper motor. The motor will control the draw rate of the fiber from the preform. This will also be under the control of the crew member so that adjustments can be made to affect the diameter of the fiber. Holding the preform tip temperature constant, a faster draw speed will result in a small diameter fiber. This will be an important aspect of this project

6.2.3 Fiber Coating System

In order to prevent abrasion and water absorption and therefore failure of the fragile fiber, an ultraviolet curable acrylic material will be applied to the ZBLAN glass fiber. A syringe pump will contain and distribute the coating material. As the syringe pump is activated a small liquid bridge will form within a cup through which the fiber passes. After exiting the coating cup a UV lamp will cure the acrylic coating. The total amount of acrylic stored within the syringe pump will be less than 40 milliliters.

6.2.4 Containment Housing

Since the FPA will contain potentially hazardous materials it is necessary to design the system for up to three levels of containment. Preliminary discussions with the JSC Toxicologist indicate the possibility that only two levels of containment may be necessary to meet safety requirements however at this time a worse case scenario is being assumed which will require three levels. The toxicity of ZBLAN is low to none as long as the vapor pressure is not exceeded. A typical formulation for the ZBLAN fiber manufactured by IFS, Inc., composed of 55.8 mole% ZrF_4 , 14.1 mole% BaF_2 , 5.8 mole% LaF_3 , 3.8 mole% AlF_3 , and 20.2 mole% NaF . In the cladding layer of the preform about 14 mole% of HfF_2 is substituted for the ZrF_4 . The UV curable acrylic is the only other potentially hazardous material used in this system.

Assuming that three levels of containment are necessary then the simplest method to provide this is a "box within a box within a box" arrangement with O-ring seals at each level. The designing and fabrication of a sealed container represents the most expensive item to be built in this project.

Both the PPF and FPA containment housings will be purged with ultrahigh purity argon gas for a period of time sufficient to lower the water concentration to below 1 part per million (ppm). Water contamination is the greatest concern when working with HMFG formulations and must not be allowed to infiltrate the environment around the glass when at working temperatures. Due to this purging action, an additional benefit is the elimination of oxygen (and any other gases) from the containment housing as well. This will as result help the safety aspects and concerns of flammability. Purging will be performed just prior to the integration process at KSC and not during flight. No overboard venting from either facility during flight is deemed necessary at this time.

6.3 Data Acquisition and Control System (DACS)

In the course of this study, numerous suppliers of computer equipment which have application to this project were reviewed. It was determined that the most cost effective, space and power saving system will be of a STD bus architecture. It is the intent of this project to utilize as much off-the-shelf board level hardware as possible and custom built as little electronic hardware as

possible. Of all the vendors of STD products thus far, Ziatech Corporation is the preferred choice. Their hardware has already flown several times on the Orbiter with good results and they can provide all of the necessary products to completely build a data and control system. Since the two facilities are very similar in data and control requirements, the intention is to recycle the DACS from the PPF and use it in the FPA system.

In both facilities the DACS will control all aspects of the hardware. In addition to inputs made the by the crew, the DACS will operate, collect, process and store the analog and digital data, and condition and distribute power to all of the subsystems. There is no critical need to downlink or uplink in real time any data or commands to either facility through the Orbiter's interface system.

6.3.1 Preform Processing Facility DACS

In the operation of the PPF numerous control functions and measurements will be performed. Depending on the total number of heater assemblies to be included within one facility, the total number of actions has yet to be determined but will be a multiple of the following:

Subsystem	Control Functions	Measurement Functions
Heater	heater temperature sample temperature thermal safety switch	2 thermocouples 3 thermocouples 1 voltage sensor
Copper quench block	block temperature cooling pump (if needed)	2 thermocouples 1 flow switch 1 pressure sensor
Linear actuator	stepper controller sample position	1 rotation encoder 1 linear displacement trans. 2 micro switches
Power	power distribution	8 voltage sensors

Exhibit 12. DACS Functional Description for PPF

A custom built card cage assembly will hold the various STD boards. These boards include a single board computer, analog to digital converter board, input/output board, servo controller, and solid state disk. The single board computer includes system DRAM, BIOS, software EEPROM, serial and parallel ports, display driver and port and real time clock. The A/D board will receive conditioned data from the various sensors. Conditioning of the signals will be accomplished using Analog Devices 3B series signal conditioners. Exhibit 13 provides a block

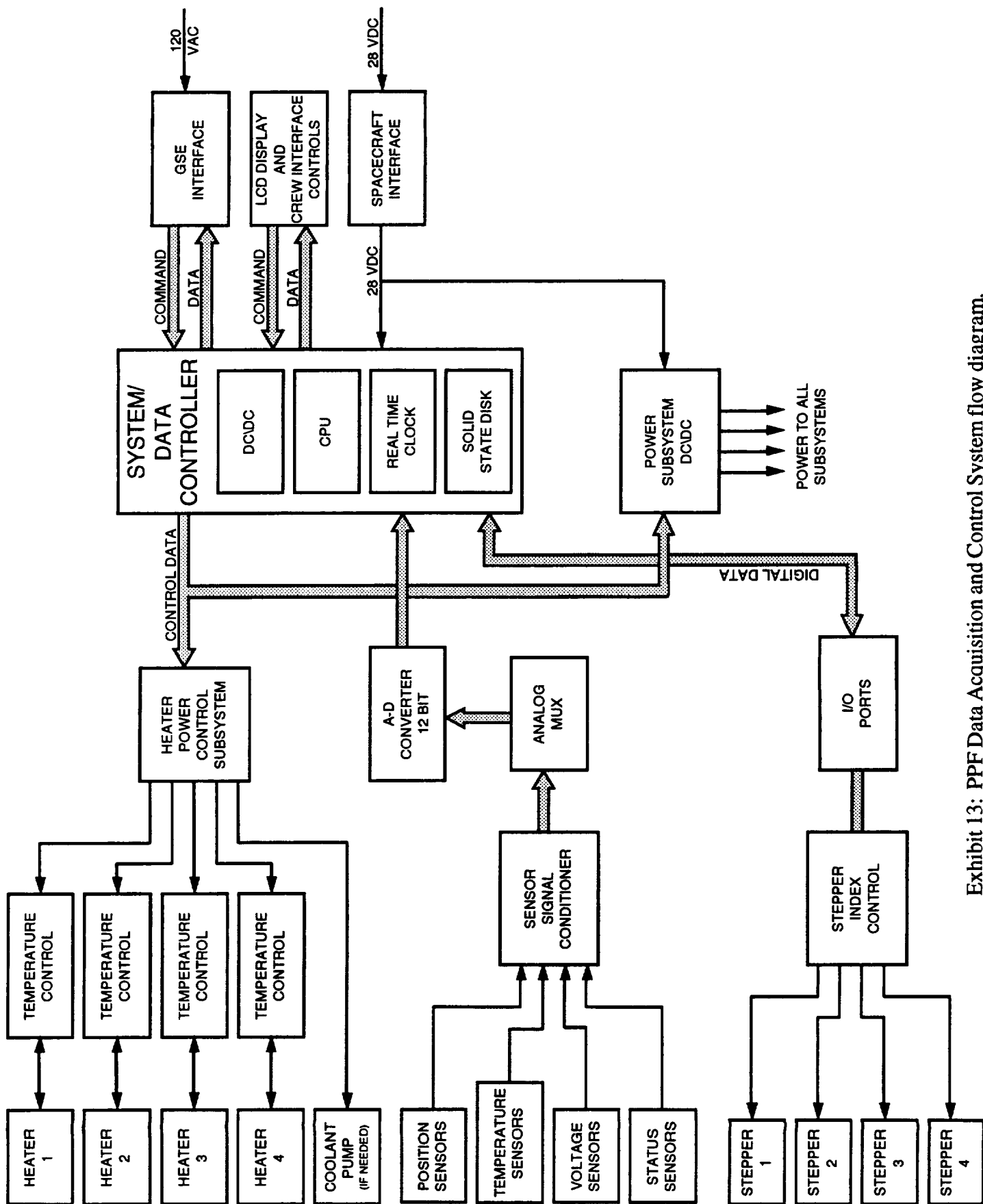

Exhibit 13: PPF Data Acquisition and Control System flow diagram.

flow diagram of how the system is laid out. All of the boards will be vibration hardened, cleaned, and conformal coated to seal them from contamination and also to prevent off gassing. With the exception of the crew initiating the start of the experiment by simply powering up the facility, the operation of the PPF will be totally automatic. Each heater/quench block assembly will be operated by the DACS and sequenced one at a time. The crew shall have the ability to interrupt, pause or terminate the facility at any time as required. Also by interfacing the Orbiter's PGSC to the RS-232 serial port the crew can gain entry to the command and control software and implement trouble shooting procedures, override and initiate various processes within the facility if so desired and approved. A liquid crystal display mounted on the front of the housing will provide the crew with a continuous status indication of how the facility is operating.

6.3.2 Fiber Pulling Apparatus DACS

As mentioned previously the DACS from the PPF could be removed and installed into the FPA for cost efficiency. In some regards the control of this facility is simpler in that there is only one heater and fiber drawing system per facility. This eliminates several stepper motors and the associated hardware and software. The main differences in this system as compared to the PPF include only one heater, temperature controller and two stepper subsystems. One stepper motor will be used in the fiber take up reel and the second one for the fiber initiation subsystem.

Subsystem	Control Functions	Measurement Functions
Heater	heater temperature thermal safety switch	2 thermocouples 1 voltage sensor
Fiber Take Up Reel	stepper controller	1 rotation encoder
Fiber Initiator	stepper controller solenoid actuators	1 rotation encoder 1 linear displacement trans. 4 micro switches
Fiber Coating	UV lamp syringe pump	1 voltage sensor 1 position transducer
Fiber/Heater Cooling	water pump fan	1 flow sensor no sensor for fan
Power	power distribution	6 voltage sensors

Exhibit 14. DACS Functional Description for FPA

Exhibit 15 provides a block diagram of the FPA system. One primary difference of this system when compared to the PPF is that two video camera signals will be incorporated into the data

acquisition system. A color TFT LCD flat panel display will provide the operator with the information to control the process. This display panel can incorporate full motion video overlaid with graphical data. The combined video images can then be ported to any VRC for a permanent copy of the video data. This will also serve as a backup copy of the data being stored on the solid state drive. A LCD display is preferred over the conventional CRT due to lower power requirements, no radiation emissions, small size and the ease of integrating a touch screen with an environmental seal. A touch screen on the display will provide some of the control functions for the FPA. This will include such parameters as heater temperature setpoint, coating application rate, draw rate of the glass fiber, and minor functions such as illumination lighting for the cameras. The two cameras will image the jet zone located at the softened tip of the preform and the spooling of the fiber on the take up reel.

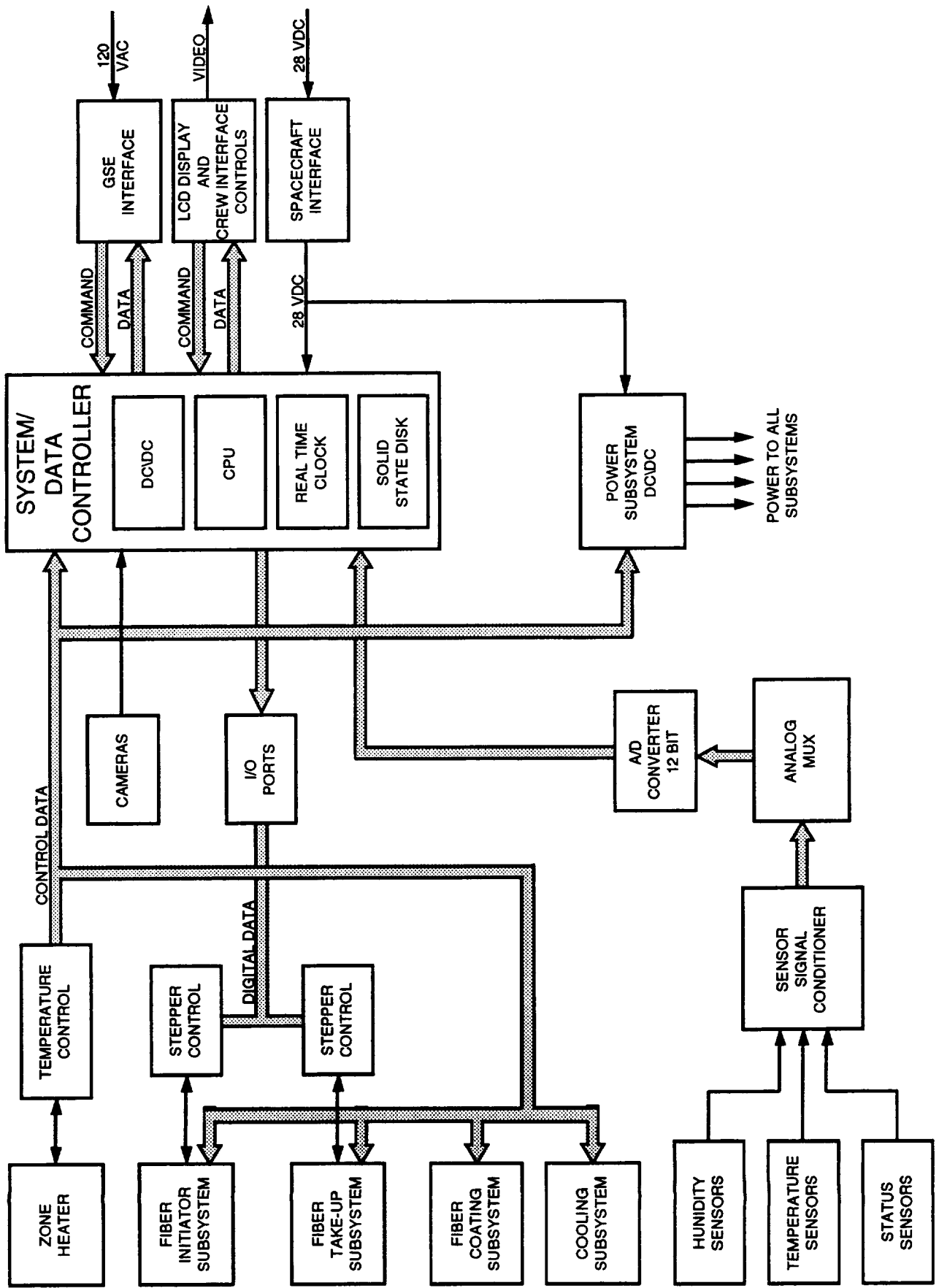

Exhibit 15: FPA Data Acquisition and Control System flow diagram.

In the operation of the FPA one crew member shall be required to monitor and manage the facility through most of its procedure. In the normal course of the run this will be a time period of 3.5 hours. The most critical point of the crew interface will involve the initiation of the fiber drawing process. There is no way to reliably automate this process. Therefore, it is necessary that a crew member actually inserts the stinger into the preform melt and withdraws it thus starting the fiber. To accomplish this a number of controls located on the face of the housing and a view port located in front of the fiber draw area will be provided to control the insertion and withdraw process of the stinger. Once the fiber has begun to draw, the crew member will only monitor the fiber diameter and control the draw rate which determines the diameter of the fiber. Heater temperature and preform feed rate into the heater will also be provided to adjust those parameters if necessary. Up to two cameras may be located within the facility housing to provide a video signal for recording on one of the Orbiter's VCRs. That recording can then be down linked at a later time when convenient. Ideally it will be preferred to down link the video in real time if that was possible on a non-interference basis with the rest of the Orbiter's operations.

6.4 Power and Weight Specifications

In the interests of simplicity both hardware systems are designed for use in the Orbiter Middeck avionics bay areas only. While this may limit the flexibility of the design this does not appear to be a constraint on the performance characteristics of either system.

6.4.1 Power Budget

Both systems will utilize the Orbiter's 28 VDC supply only. The required voltages for the various electronic systems will be provided by the systems own internal DC to DC converters. Exhibits 16 and 17 provides a preliminary power profile for each system. The current anticipation is that both facilities will stay within the 5 amp standard limit for Middeck payloads, although it may become necessary to increase this slightly for the FPA. Wattage requirements may be greater than 115 due to the number of subsystems all operating at the same time. Every attempt will be used to keep the requirement as close to 115 watts as possible.

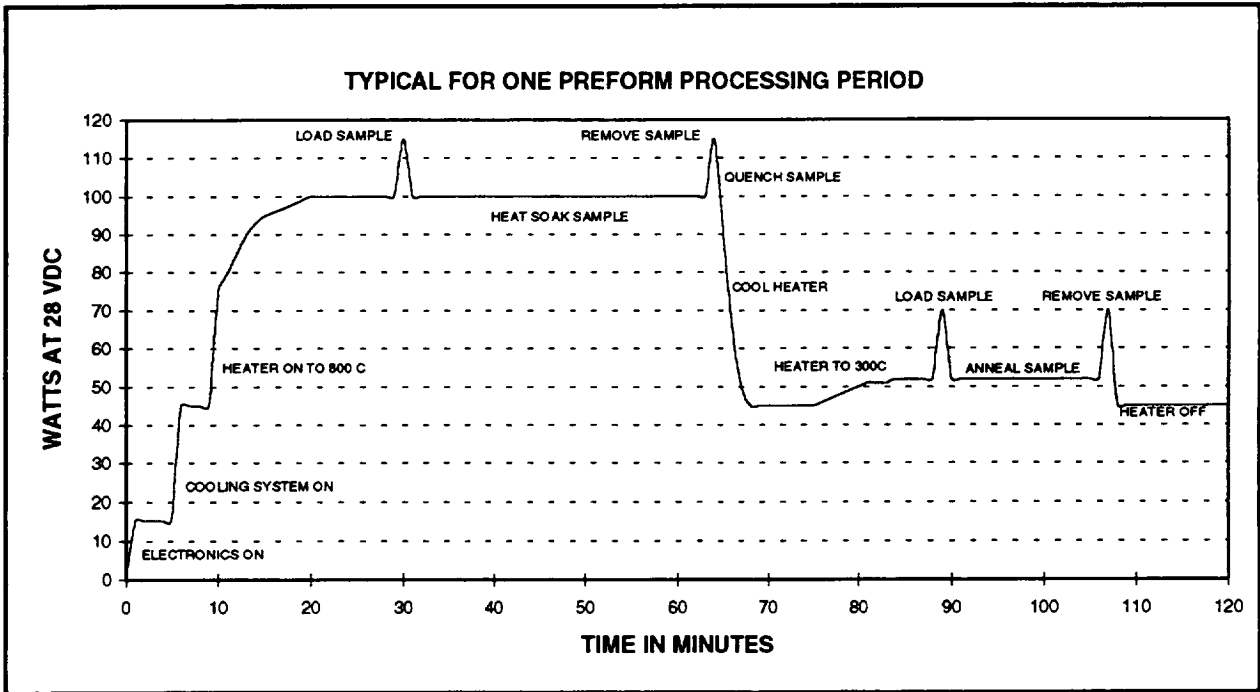

Exhibit 16: Power Profile Concept for the PPF

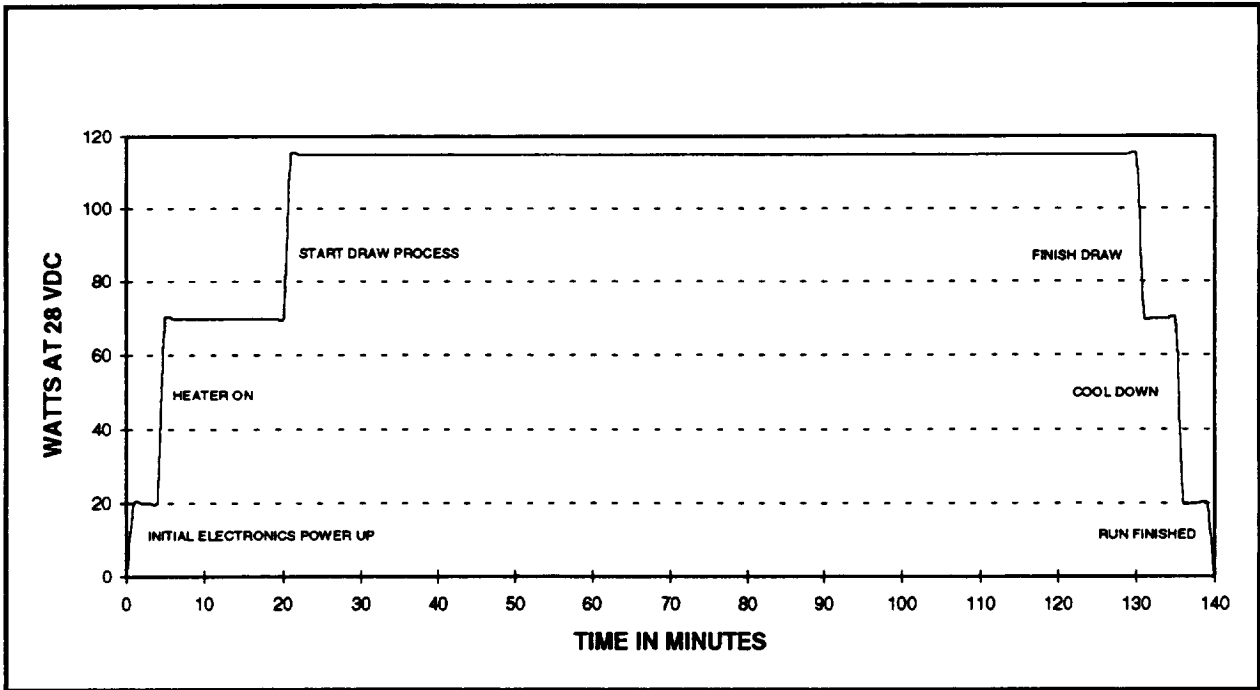

Exhibit 17: Power Profile Concept for the FPA

6.4.2 Weight Budget

According to the Middeck IDD (NSTS-210000), section 4.8.1, the weight limitations for a standard Middeck locker payload is 70 pounds provided that the center of gravity is no more than 14 inches from the locker attached face. According to section 4.8.2.3, a payload using the double Payload Mounting Panels is limited to 120 pounds provided the center of gravity is located no more than 14 inches from the attached face. The PPF and FPA will fall within those weight limitations.

6.5 Ground Support Equipment

GSE for either of the two facilities will be minimal. At this time only a laptop PC, 28 VDC power supply and temperature readout is anticipated for ground checkout of either systems. Should disassembly be required for trouble shooting procedures or inspection at KSC then additional hand tools, ultra high purity and dry Argon purge gas, and expendable replacements such as O-rings will also be needed. A portable glove box for providing a dust free environment during operations on the FPA will also be needed. Dust contamination and water vapor on the glass preform can induce unwanted heterogeneous nucleation on the fiber as it is being drawn. Presently, there are no specialized or custom built GSE items planned.

6.6 Design Guidelines

6.6.1 Documentation

Documentation requirements shall be minimized where possible for lower costs. Required functional, performance, and quality test will include documentation. Each test procedure will attain approval prior to testing. Each instrument will include test data with the shipments. A PC-based Computer Aided Design (CAD) package will be used to construct all drawings.

6.6.1.1 Reference Documents

The following documents are included for reference to the extent specified. If there is a conflict between this document and any other document referenced, the contents of this document shall apply.

- JA-012D Payload Safety Implementation Approach
- JSC-SN-C-0005A Specification, Contamination Control Requirements for the Space Shuttle Program.
- JSC-R-0022A General Specification Vacuum Stability Requirements of Polymeric Material for Spacecraft Applications.
- JSC 20584 Listing of Spacecraft Maximum Allowable Trace Gas Concentrations.
- JSC-20793 Battery Safety Handbook
- MIL-B-5087B Bonding, Electrical, and Lightning Protection for Aerospace Systems.
- (MSFC) 40M38277 Specification, Connectors, Electrical, Circular, Miniature High-Density, Environment Resisting.
- (MSFC) 40M39569 Specification, Connectors, Electrical, Miniature Circular Environment Resisting.
- MSFC-STD-506 Standard, Material and Process Control.
- MSFC-SPEC-521B EMI Test Requirements.
- MSFC-SPEC-522B Design Criteria for Controlling Stress Corrosion Cracking
- MSFC-HDBK-527 Materials Selection List for Space Hardware Systems.
- MSFC-SPEC-250 Protective Finishes for Space Vehicle Structures and Associated Flight Equipment, General Specification.
- MSFC-STD-561 Thread Fasteners, Securing of Safety Critical Flight Hardware Structure Used on Shuttle Payloads and Experiments
- NASA-STD-3000 Man-Systems Integration Standards, Vol. 1.

- NHB 1700, Vol. 1 NASA Basic Safety Manual.
- NHB 8060.1 Flammability, Odor, and Offgassing Requirements and Test Procedures for Materials in Environments that Support Combustion.
- NHB 8071.1 Fracture Control Requirements for Payloads Using the National Space Transportation System (NSTS).
- NSTS 1700.7B Safety Policy and Requirements for Payloads Using the Space Transportation System (STS)
- NSTS 13830B Implementation Procedure for NSTS Payloads Systems Safety Requirements.
- NSTS 14046 Payload Verification Requirements.
- NSTS 18798A Interpretations of NSTS Payload Safety Requirements.
- NSTS-21000-IDD-MDK Shuttle/Payload Interface Definition Document for Middeck Accommodations
- NSTS 22648 Flammability Configuration Analysis for Spacecraft Systems.

6.6.2 Electrical Requirements

The FPA and PPF power systems will run on the 28 volt DC power provided by the Orbiter. These systems will convert the voltage to the necessary power required for each subsystem. In the event of a variation in the supply voltage, caused by the mission environmental conditions, the FPA and PPF shall not behave irregularly. Internal electronic filtering will prevent any failures or discontinuities in the operation of the systems due to fluctuations in the supply voltage.

6.6.2.1 Electromagnetic Interference (EMI)

The electrical EMI created by the FPA and PPF will be investigated and alleviated as required, using appropriate guidelines. The EMI tests will include ripple and transients, conducted, and radiated.

6.6.3 Material Selection and Process Control

In the fabrication of the FPA and PPF systems, material selection will utilize the specification and material requirements in the NSTS 22648 guideline. A list of the materials, parts and processes to be used in fabrication of the two flight hardware systems will be submitted for approval at the Critical Design Review (CDR).

6.6.4 Hardware Life Requirement

The minimum mission lifetime of the experiments will be seven days, in addition to pre-launch use such as ground testing, checkout, and storage. The maximum storage life in warehouse storage conditions, inside the shipping container, will be two months for the facilities, any spares and associated GSE. Any parts determined to be sensitive to age will be identified and reviewed as an item in the CDR. If age deterioration is a factor, a maintenance procedure, with the indicated replacement cycle and/or required retesting, will be submitted for the CDR. The FPA flight hardware will be designed as a reusable, multifunction flight processing facility capable of producing not only ZBLAN fibers but also other material based optical fibers. Likewise, the PPF flight hardware shall be designed as a reusable, multifunction flight processing facility capable of a bulk sample melt and resolidification process. Uses of both the FPA and PPF could include a multisample facility capable of flight on the International Space Station with modifications.

6.6.5 Environmental Design Requirements

Exposure to many environmental conditions from the time the FPA and PPF systems leave the final assembly area until post-flight processing can cause abnormalities to the systems integrity. Due to the systems design, humidity and contamination will not be a factor of degradation on the facility. The system design includes an enclosed double o-ring sealed housing that will be back filled with argon. The performance of various tests to simulate the expected conditions during a space mission will verify the FPA and PPF's capability to withstand other extreme environmental parameters seen by the facility. Documentation of each test conducted and their results will be written for all performance and qualification tests. The performance tests verify each subsystem's capability to measure and/or operate within the correct parameters. The qualification tests verify

the FPA and PPF systems are capable to operate within the correct parameters during the flight and survive the mission. A list of the test conditions include, but are not limited to:

- Acceleration
- Vibration
- Shock
- Temperature
- Off gassing
- Acoustics

6.6.5.1 Ground Handling Environments

During the integration of the FPA and PPF into the Shuttle, naturally occurring exposures to pressure, temperature, humidity, material contamination, and dynamically induced conditions of acceleration, vibration and shock could occur. The planned integration procedures and First Article Test (FAT) will minimize exposures to uncontrolled conditions.

1. Pressure - Atmosphere

a) Pressure

- i) Surface Nominal 12.36 to 15.23 psia
- ii) Air Shipment - 35000 feet 3.28 psia minimum

b) Atmosphere:

- i) Normal Atmospheric Constituents

2. Temperature

a) Uncontrolled areas (loading docks, aircraft cargo areas, etc.)

- i) Surface -23° to +150° F
- ii) 35,000 feet -65° F minimum

b) KSC areas

TBD

c) Orbiter Processing Facility

TBD

3. Humidity

0-95%, non-condensing

4. Contamination Considerations

TBD

5. Acceleration

The acceleration of gravity at 1 g (32.14 ft/sec²), may be considered a constant applied at all times during ground testing. However, ground handling will superimpose short term steady state accelerations of up to 2 g vertical loads, with a cone angle of 20° from the vertical..

6. Vibration (Transportation)

The exposure definition is a minimum of four sinusoidal sweeps at 1/2 octave per minute as follows:

- a) 2 to 5 Hz: 1 inch double amplitude displacement
- b) 5 to 26 Hz: 1.3 g 0 to peak

c) 26 to 50 Hz: 0.036 inch double amplitude displacement

d) 50 to 1000 Hz: 5 g 0 to peak

7. Shock (Bench Handling)

The maximum conditions are defined as exposure to 20 g terminal peak saw-tooth pulses. The pulses are of 11 millisecond duration, in both directions along each of the three mutually perpendicular axes.

7.0 FLIGHT EXPERIMENT

The design and capabilities of the PPF/FPA flight systems were presented in Section 6. In this section the baseline mission and the flight requirements of the total PPF will be presented.

7.1 Baseline Mission Objectives

To successfully demonstrate a benefit for commercial materials processing of fluoride fibers, both preform and fiber pulling processes are required. The nature of the detrimental characteristics in the final optical fiber products is due to undesirable nucleation phenomena, which can occur at either step in the process. Hence for a more precise interpretation of the effects of gravity on the processes involved in optical fiber production, both preforms and optical fibers need to be returned from space for analysis by the industry partners in the flight activities

In the time frame estimated for flight, a Shuttle mission is expected. Since the PPF/FPA benefits are derived from the microgravity environment, all the activities for processing of either preforms for a PPF mission or pulling fibers in a FPA mission can easily be handled within one shuttle mission. The flight hardware for both PPF and FPA does possess some redundancy to reduce overall costs, hence two Shuttle missions are necessary to process both preforms and fibers.

7.2 Baseline Mission Timeline

The timeline for the initial PPF mission can be described in three phases - pre-launch operations, flight operations, and post-flight operations.

7.2.1 Pre-Launch Operations

The completely instrumented flight apparatus containing the samples will be sent to KSC within the required payload integration period to assure easy integration into the Shuttle. No sampling loading or other operations of this nature just prior to launch will be necessary. Upon arrival of the hardware to KSC one day of ground checkout operations will be required to insure the health of the systems prior to loading into the Shuttle.

7.2.2 Flight Operations

Flight operations are concerned only with performing the preform processing or the fiber pulling operations. In the case of the PPF operations, no crew activity is required except to turn the apparatus on, at which time the computer controls will take over, and perform an occasional monitoring of the system status. The fiber pulling operation is more difficult and will require that a crew member or payload specialist assist in beginning the draw and monitoring the progress of the fiber pull. Depending upon real time conditions during the fiber draw, changes in system parameters may and probably will be required in order to obtain the correct size of fiber diameter. It is during these times that real time video down link would be helpful in assisting the operator in making decisions. One must remember that this is the first time an optical glass fiber has been drawn in space. It is therefore prudent to expect the unexpected.

7.2.3 Post-Flight Operations

The industrial partners will be responsible for determining the success of the flight processed material by performing their usual tests for homogeneity and presence of microcrystalites. In the case of the space processed preforms, actual fiber draws can be performed on earth to help isolate the actual occurrence of the microcrystalites and their impact on the transmission characteristics of ZBLAN optical fibers. The optical fiber actually pulled in space will be analyzed for its improved transmission characteristics.

8.0 DEVELOPMENT PHASE IMPLEMENTATION PLAN

The development phase for both the preform annealing and the fiber pulling experiments includes all activities required to develop the flight hardware, perform each experiment on the Shuttle, and perform post-flight activities. A preliminary schedule and cost estimate is provided in this section.

Consistent with the current NASA philosophy of developing experimentation with a reasonable compromise between minimum risk and minimum cost, the flight apparatus has been designed following those guidelines. The flight hardware will be built as discussed in section 6. Three units of each facility will be built with one serving as the ground unit and as back-up. Keep in mind that some components of the PPF can be utilized in the FPA for cost savings. Full qualification testing will be performed at the PPF/FPA level with component and subsystem level environmental testing limited to special items.

Single Failure Points (SFP) will be allowed in the design, but system critical SFP's will be minimized through the use of redundant components where the cost impact is minimal.

8.1 Schedule

A summary schedule of the FPA Development phase is shown in Exhibit 18. The start date, October 1, 1994 is projected for the development phase to begin. This program can then be divided into two overlapping phases due to the plan to utilize some of the apparatus for both the preform processing and fiber pulling flights and a third phase which is used to for mission analysis activities. Phase I begins with the authority to proceed with PPF development, and continues through delivery of qualified flight hardware for the PPF. During flight preparation for the PPF, the fiber pulling subsystems will already be fabricated and tested, so that upon return of the PPF, the fiber pulling subsystems can be assembled into the flight containment apparatus for the FPA mission. Payload integration and mission support for both the PPF and the FPA is included in Phase II. As mentioned above, Phase III is the post-flight phase for both experiments.

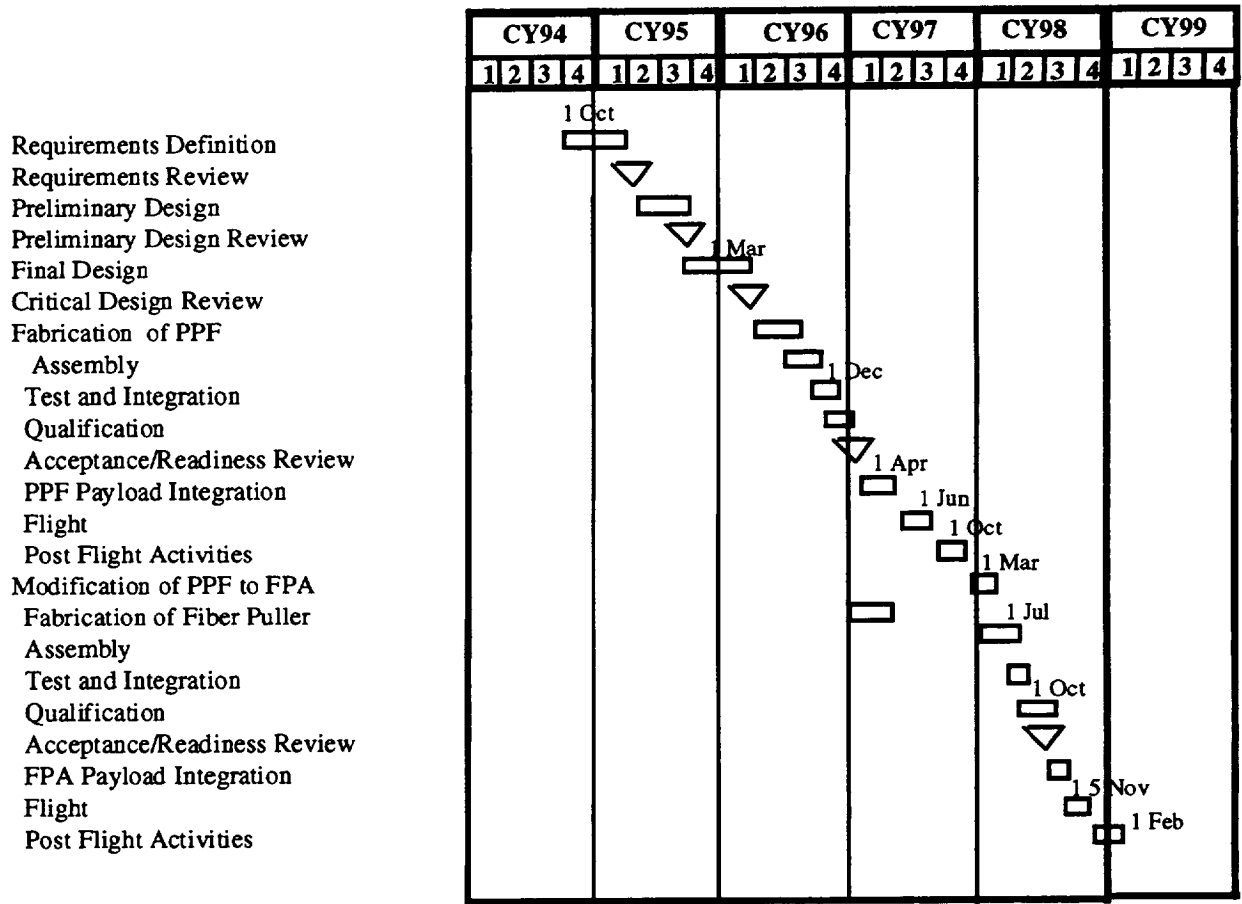

Exhibit 18. PPF/FPA Summary Schedule

8.1.1. Phase I

The initial phase is divided into two areas; hardware development and mission planning support activities. Within these two areas, major milestones define the schedule progress. The milestones for the hardware development include systems requirement review, Preliminary Design Review (PDR), Critical Design Review (CDR), and the Acceptance/Readiness Review (ARR). The milestones for the mission planning support activities include multiple safety reviews, Cargo Integration Review (CIR), Flight Operations Review (FOR), and Payload Readiness Review (PRR). Phase I is expected to take 24 months to complete.

8.1.1.1 Hardware development

The hardware development phase includes all activities to design, fabricate, and test the PPF hardware. The major milestones relate to the stage of mission maturity and hardware development. At the beginning of hardware development, the mission definition, design guidelines and system requirements are reviewed for completeness and adequacy to meet PPF objectives. The SRR is held to ensure that all ground rules for the final design and development are complete and to signify that the preliminary design effort is ready to proceed.

The preliminary design effort begins with updating the definition phase information where necessary. The major details of the design are checked for completeness and to verify component and/or subsystem availability. The interface between all subsystems is verified. Make/buy trade studies are performed. Vendor selection is made for those parts to buy; the remaining parts are identified for fabrication. The specifications required for the final design are identified. Test plans are outlined that identify components for test, the type of tests to be conducted, and variance limits. The software to operate the experiment is functionally defined and documented with flowcharts. The payload accommodations are checked to assess the latest requirements and compatibility for the PPF and the FPA experiments. The PDR is held to ensure that all aspects of the design are covered prior to the beginning of the final design.

The final design proceeds with the development of specifications, documentation, detailed test procedures and detailed drawings. The specification lists will consist of NASA, commercial, and military documents. The documentation provides an audit trail of design changes, revisions, and configuration management. Detailed test procedures are necessary to define the types, conditions, and expected results of each test. The drawings, documentation and specifications become the Technical Data Package (TDP) for procuring and fabricating the experiments. During this phase, software is designed down to the subroutine level as data and control flow for each routine is developed. Long lead items for both the preform process and the fiber pulling subsystems are procured. At the CDR, the detailed design is reviewed for completeness. Action items are resolved prior to completing the CDR.

After the CDR, hardware is procured or fabricated according to the TDP developed in the final design. Piece-part subsystem assembly begins and continues through the final assembly of the flight hardware. Functional tests of specific subsystems are required to verify acceptable operation prior to integration. During this phase the software code is developed, tested, and verified. The GSE is procured, fabricated, and assembled. Functional testing of the GSE is performed to verify proper simulation of the flight hardware and spacecraft interface. The software is also developed, tested and verified through GSE during this phase. Once the PPF integration is complete, the instrument is tested for functional performance verification.

Qualification tests are performed when the functional testing has been completed. Qualification tests will include tests for shock, vibration, thermal, off gassing and EMI.

After completion of all testing, Acceptance Readiness Review (ARR) is performed. During this review the apparatus is approved as passing all requirements, all documentation is acceptable and ready for shipment, the test reports are completed and verified, the software has been demonstrated and validated, and the instrument drawings are certified as complete. A satisfactory review signifies that the hardware development is complete and the PPF flight hardware is ready to ship to KSC. The flight samples are then obtained from the commercial partners, installed into the PPF and the entire ensemble is then shipped to KSC for payload integration.

8.1.1.2. Mission Planning Support Activities

Mission planning support activities include all payload safety and integration related items that must be accomplished to verify the PPF experiment is flight ready. The major milestones relate to the stage of development of the instrument. The Request for Flight Assignment (NASA Form 1628) is submitted once the Development Phase Effort begins. The Phase 0 safety review occurs early in the program to ensure that the basic requirements and processes are understood. A listing of the hazards will be ready at this time. The payload requirements are identified.

The Phase I safety review occurs before the CDR. Items required for this review include a list of hazard controls for the hazards list identified in the Phase 0 safety review, a preliminary flight materials list, the preliminary flight materials list, the preliminary structural and thermal analysis of

the instrument and applicable test reports, the final PIP and ICD and a draft of the flight procedures.

The Phase II safety review precedes the delivery of the PPF to KSC where the payload integration process begins. The hazards analysis is complete and the following items are delivered: as-built drawings, the critical structures final report, and all final test reports.

The CIR is conducted after an assessment is made of the instrument's compatibility with other payloads and the Shuttle. NASA requires detailed design information regarding the development of the payload. This information is contained in the PIP and the ICD documents. The CIR must be completed prior to final preparation for the mission.

Mission training begins with the interface of the PPF investigators with the Shuttle flight crew and flight operations personnel. Periodic reviews occur during flight operations and culminate with the Flight Operations Review (FOR). This review is held to support the final phase of the flight crew and flight operations personnel training. It is noted that the PPF requires minimal crew activity to conduct the in-space experiment.

The Payload Readiness Review (PRR) assesses the readiness of the payload and Shuttle for the integration process. It is conducted at KSC prior to initiation of payload integration.

8.1.2 Phase II

The second phase includes the payload integration and mission support for the PPF and continues through the FRR and the return of the flight hardware samples from KSC. During the payload integration process, the PPF is integrated with other experiments flying on the Middeck. The GSE checks and verifies PPF operation and the spacecraft interface. The FRR is conducted within a month before mission launch. It verifies that all requirements have been made and certifies that all flight elements are ready to perform the mission. A summary of the important events in this sequence is displayed in Exhibit 18 on the next page.

During the flight operations, the PPF/PFA team will provide mission support to assist with any hardware problems, to revise mission objectives if necessary and to review mission status.

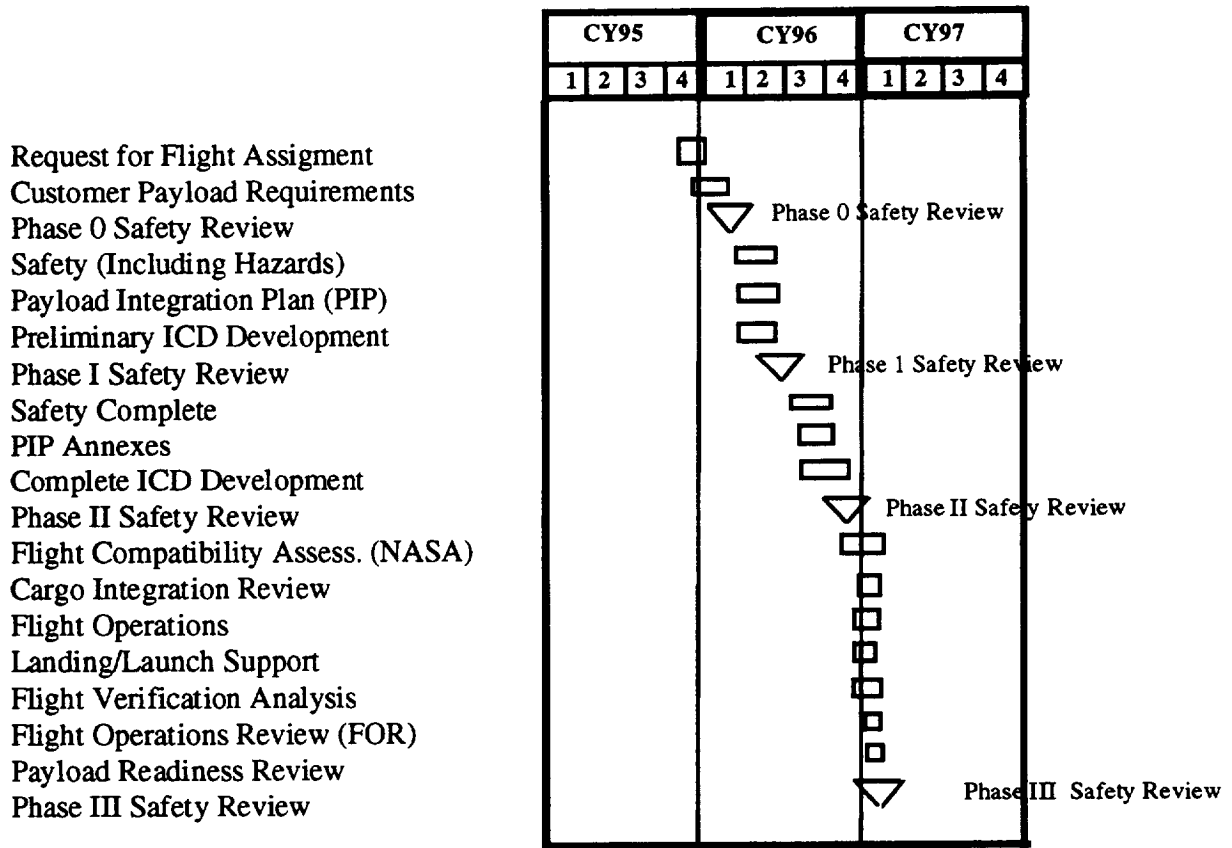

Insert Exhibit 19 - PPF/FPA Mission Planning Support Activities

Phase II is expected to transition the space flight hardware from the PPF to the FPA. Included within these activities are the fabrication and testing of the subsystems necessary to pull fiber in space. The same review sequence are then again necessary to complete the qualification and certification of the modifications which convert the PPF to FPA.

The fiber pulling mission will require more interface with the flight crew, since the initial sting function, which is necessary to begin the fiber draw process, is not easily automated. The flight operations will require a crew member to assist in that process, as detailed in section 6.2.2 and 6.3.2

8.1.3 Phase III

The Phase III effort will include all aspects of distributing samples retrieved from the in-space processed samples to the commercial investigators and documenting the results of their analyses.

In the case of the ZBLAN processed in Phase I using the PPF, one preform will be analyzed optically to determine the level of crystallite formation and then used for the Phase II fiber pulling experiment.

8.2 Cost Analysis

A preliminary cost estimate for the PPF/FPA mission has been developed using a bottoms-up engineering estimate approach. The cost estimate summary is presented in Exhibit 20. The costs are broken down by fiscal year and function. The total hardware cost for both the PPF and the FPA hardware is less than \$1.8M, which reflects the low cost approach to space hardware development.

Function	FY95	FY96	FY97	FY98	Total
Hardware - PPF and FPA	25	1500	200	0	1725
Integration and Mission Support	0	0	30	20	50
NASA Documentation and Review Support	200	100	50	0	350
Data Analysis	0	0	100	150	250
Totals	225	1600	380	170	2375

Exhibit 20: PPF/FPA Cost Estimate

9.0 SUMMARY

The commercial benefits from space processing has an opportunity to be demonstrated in the combined preform processing and fiber pulling facilities as shown in this document. The high probability of success for this mission is shown by previous scientific work on optimizing an acceptable formulation for optical fiber applications (ZBLAN) and continuing evidence of the merits of microgravity processing for decreasing the possibility of crystallite formation. The mission profile as shown here also allows the commercial partners the ability to distinguish between preform processing and/or fiber pulling as an optimizing process to obtain improved commercial products.

The PPF/FPA approach is a compromise between low cost and low risk. Qualification testing will be performed at the system level with minimal component and subassembly environmental testing. To increase reliability, redundant components will be used at critical system failure points and where the cost impact is low. Several cost benefits in performing the mission are also derived from using separate subsystems for the preform processing and the fiber pulling; but reusing the redundant subsystems such as the control and containment items. Not only are the overall fabrication costs reduced, but also the costs associated with test and qualification.

The PPF/FPA can be a very significant processing facility for commercial interests who wish to take advantage of the microgravity environment to improve upon optical fiber capabilities. The facilities are re-usable and will be able to support industry from Shuttle through the Space Station.

REFERENCES

1. Lightwave , May 1993, p. 1
2. Lightwave, June 1993, p. 6
3. Lightwave, Sept., 1993, p. 56
4. Lightwave, Dec. 1993, p. 9
5. Marcy Koff; "Submarine Fiber-Optic Cables Swim to Distant Shores," Lightwave Magazine, May 1994, p. 57
6. Marcy Koff; "Government Report Cites Widespread Increases in Fiber-Network Deployments," Lightwave Magazine, July 1994, pp. 48-51.
7. Drexhage; "Infrared Glass Fibers," SPIE Infrared Fiber Optics II, Vol. 1228, 1990, pp. 2-11.
8. Tran, K.H. Levin, R. Mossadegh, R.F. Bonner, and M. Leon; "Surgical Applications of Heavy Metal Fluoride Glass Fibers," SPIE Infrared Optical Materials VI, Vol. 929, 1988, pp. 115-118.
9. Jacques Lucas; "The History of Fluoride Glasses," Materials Science Forum, vol. 19-20, 1987, pp. 3-10.
10. S.Shibata, et. al., Elect. Ltrs, 17, (1981) 1775
11. Lines; "Theoretical Limits of Low Optic Loss in Multicomponent Halide Glass Materials," Journal of Non-Crystalline Solids 103, pp. 265-278
12. MacFarlane and L.J. Moore; "Nucleation as a Function of Temperature in the $ZrF_4 - BaF_2$ Glass Forming Systems around T_g ," Materials Science Forum, vol. 19-20, 1987, pp. 447-452.
13. Doremus; "Crystallization of Fluoride Glasses," Materials Science Forum Vol. 19-20, 1987, pp. 431-434.
14. Drehman; " Crystallite Formation in Fluoride Glasses," Materials Science Forum, vol. 19-20, 1987, pp. 483-490.
15. Carter, P.W. France, M.W. Moore, and J.R. Williams; "Crystallization in a ZBLANP Core Glass and Optical Fibres," Materials Science Forum, vol. 19-20, 1987, pp. 511-514.
16. Bruce and J. W. Fleming; "Crystallization in Large Volume Samples of Fluoride Glass," Materials Science Forum, vol. 19-20, 1987, pp. 491-510.

17. Tran, C.F. Fisher, and G.H. Sigel; "Fluoride Glass Preforms Prepared By a Rotational Casting Process," *Electronics Letters*, Vol. 18 No. 15, July 22, 1982, pp. 657-658.
18. Ray, and D.E. Day; "Glass Formation in Microgravity," *Material Research Society Symposium Proceeds*, Vol. 87, pp. 239-251.
19. Zarzycki, Frischat and Herlat in *Fluid Sciences and Materials Science in Space A European Perspective*, ed. H.U. Walter, Springer-Verlag, New York, 1987, pp. 599-635
20. Meier and G. H. Frischat; "Comparison Between Micro-G and Macro-G Interdiffusion Experiments in Glass Melts," *Proceedings VIIth European Symposium on Materials and Fluid Sciences in Microgravity*, ESA SP-295, Jan. 1990, pp. 253-256.
21. Varma, S.E. Prasad, I. Murley, and T. A. Wheat; "Use of Microgravity for Investigating Phase Separation and Crystallization in a Heavy Metal Fluoride Glass," *SPIE Infrared Fiber Optics III*, Vol. 1591, 1991, pp. 14-25.
22. Project Report, NASA/MSFC, NAS8-68309, D.O. 15
23. Project Report, NASA/MSFC, NAS8-68309, D.O. 102
24. Project Report, NASA/MSFC, NAS8-68309, D.O. 112
25. D. S. Tucker, "Effect of Microgravity on Crystallization of ZBLAN Fibers," *NASA Technical Memorandum 108461*, June 1994.

Report Document Page

1. Report No.		2. Government Accession No.		3. Recipient's Catalog No.	
4. Title and Subtitle Phase A. Design Study of Microgravity Fiber Puller				5. Report Due	
				6. Performing Organization Code University of Alabama in Huntsville	
7. Author(s) Gary L. Workman, Guy A. Smith Sue Kosten				8. Performing Organization Report No.	
				10. Work Unit No.	
9. Performing Organization Name and Address University of Alabama in Huntsville Huntsville, Alabama 35899				11. Contract or Grant No. NAS8-38609, D.O. 112	
				13. Type of report and Period covered <i>FINAL</i>	
12. Sponsoring Agency Name and Address National Aeronautics and Space Administration Washington, D.C. 20546-001 Marshall Space Flight Center, AL 35812				14. Sponsoring Agency Code NASA/MSFC	
				15. Supplementary Notes	
16. Abstract Improved transmission properties for fluoride fibers due to space processing has great potential for commercial benefits. Phase A design study will determine conceptual feasibility and provide initial definition of the technical requirements and design issues for space.					
17. Key Words (Suggested by Author(s)) Fibers, Materials Processing Solidification			18. Distribution Statement cc. AT01 (1) EM-13/L. Smith (1) ONRR (1) EH-34/D. Tucker (1 + repro) NASA/Sci. & Tech. Inf. Fac. (1 + repro) Vaughan/UAH (1)		
19. Security Class. (of this report) Unclassified		20. Security Class. (of this page) Unclassified		21. No. of pages	22. Price