

1995/08/10 8
350293

BP

N95-14572

Flocculation and Aggregation in a Microgravity Environment (FAME)

Rafat R. Ansari

NASA Lewis Research Center/CWRU
Mail Stop 105-1, 21000 Brookpark Road
Cleveland, OH 44135, USA

Harbans S. Dhadwal and Kwang I. Suh

Department of Electrical Engineering
State University of New York at Stony Brook
Stony Brook, NY 11794, USA

Abstract

An experiment to study flocculation phenomena in the constrained microgravity environment of a space shuttle or space station is described. The small size and light weight experiment easily fits in a Spacelab Glovebox. Using an integrated fiber optic dynamic light scattering (DLS) system we obtain high precision particle size measurements from dispersions of colloidal particles within seconds, needs no onboard optical alignment, no index matching fluid, and offers sample mixing and shear melting capabilities to study aggregation (flocculation and coagulation) phenomena under both quiescent and controlled agitation conditions. The experimental system can easily be adapted for other microgravity experiments requiring the use of DLS. Preliminary results of ground-based study are reported.

Introduction

A functional engineering model of an integrated fiber optic system for conducting in-situ dynamic light scattering (DLS) measurements has been built for microgravity science & applications, in particular, to study flocculation and coagulation of spherical polystyrene particles in aqueous solutions in the presence of long chain polyacrylamide polymer (commonly known as flocculant). The development of the engineering model and its optical, mechanical, and electrical design have been recently presented by Ansari et al¹. A Glovebox (GBX) experiment "Flocculation and Aggregation in a Microgravity Environment (FAME)" was selected by NASA for USML-2 (2nd United States Microgravity Laboratory) space shuttle flight mission scheduled to be flown in Fall 1995. However, due to the extraordinary demand on the GBX resources and a priority for mainstream experiments where GBX was required to support that activity, FAME was dropped out of USML-2 flight program. We plan to propose it for another flight at the next round of Fluids NRA. In addition to flocculation monitoring, we anticipate the use of FAME hardware, after some modification, for monitoring growth of porous materials in another future experiment by Dutta et al².

The Art of Polymer Induced Flocculation

Flocculation is widely used in the recovery of suspended material in coal and ore mining, pulp and paper making, enhanced oil recovery, pharmaceuticals, water and waste-water treatment, and pollution control of lakes and reservoirs. Flocculation is the polymer-induced aggregation of dispersed particles in a fluid based system. Details on this mechanism has been given by Attia³, Finch⁴, and Gregory^{5,6}. Industrial polymeric flocculants are generally long chain polymers. Filtration, floatation, and sedimentation operations become very effective with an increase in the particle size. The particles which are to be flocculated may have a wide size range covering colloidal (nm) to microscopic (μm) to visible (mm) particles. Perikinetic flocculation process (due to Brownian diffusion) can be very slow for dilute colloidal dispersions. It may take several hours to grow large flocs under these conditions. Orthokinetic flocculation (due to some agitation) enhances collision efficiencies and thus promotes flocculation. However, all theoretical calculations for flocculation rate constants generally apply to spherical shapes assuming a laminar flow and hence strictly to the early stages of a flocculation process.

Colloid stability is very complex because several forces can be operational. Most frequently occurring forces are van der Waals forces, electrostatic forces, and forces due to adsorbed polymers. Dispersion stability can be described by DLVO^{7,8} theory as a balance between electrostatic repulsion (ESR) and van der Waals attraction (VWA). In dilute electrolytic solutions ESR exceeds VWA. The ionic strength of the dispersion is modified to enhance particle-particle collision efficiency as high as possible for normal aggregation (coagulation) to occur. However, DLVO theory breaks down for polymer-induced flocculation because the mechanism of bridging or charge neutralization (patchwork model⁹) due to adsorbed polymer depends upon the long-chain nature of the polymer molecule. Furthermore, the polymer molecular weight should be very high ($\cong 1-20 \times 10^6$) to promote effective polymer-particle attachments. Only a small

2nd Microgravity Fluids Physics Conference, June 21-23, 1994, Cleveland, Ohio, Paper # 20

polymer chain segment is required to be adsorbed on the particle surface, while a significant amount of chain segment is extended into the fluid phase to capture other particles of the dispersion. More adsorbed polymer on the particle surface may have adverse effect on the ability to flocculate by giving rise to steric repulsion.

Scientific Objectives

The scientific objectives of the FAME investigation is to obtain data sets for a proof-of-concept study on a model system which can be used to guide the development of quantitative models of the flocculation process. This study involves aggregation (both flocculation and coagulation) of primary particles from colloidal (nm) to large (1-100 μm) aqueous particulate dispersions, thus covering a wide range of size and interaction regimes.

Currently two competing models describe flocculation in terms of either a bridging mechanism and/or an interlocking polymeric network. In the bridging model a polymer chain is considered to be adsorbed simultaneously on two or more particles. In the network model, polymer chains form an entangled network which acts as a particle trap. Because of strong gravitational settling and a lack of non-invasive techniques these theories have not been tested thoroughly. Furthermore which theory plays a dominant role is not clearly understood. Laser light scattering (LLS) experiments in the absence of gravitational effects will be able to answer questions of fundamental importance to the flocculation phenomena and thus provide new quantitative insights into various interactions and microscopic structures present in pre-flocculation, during flocculation and after the flocculation stage. The microgravity environment on-board the space shuttle orbiter or space station will eliminate the problems of sedimentation and convective diffusion. The effects of agitation on the growth of large flocs under controlled shear conditions in the absence of sedimentation in a microgravity environment has been identified as an important area of research to the materials processing in space by Naumann and Herring¹⁰. It has been suggested by Sikora and Stratton¹¹ that the reversibility or otherwise of floc breakage under shear may be an indication of whether polymer bridging or charge neutralization is the predominant flocculation mechanism. Charge neutralization generally gives weaker flocs than bridging, but the flocs readily re-form. One important practical aspect of colloid interaction is its effect on the strength of aggregates. Unfortunately this is not well understood. Varoqui and Pefferkorn¹² describe the time evolution of the size distribution of flocculating particles at large time by scaling formulas. The objective of this investigation is to clearly delineate these predictions.

Our approach is to monitor, in real time, the growth of flocs due to polymer-induced aggregation and the growth of coagulase due to salt-induced aggregation. For primary colloids, we employ the technique of DLS and for large particles, we plan to use microscopy and videography to monitor the changing size and shape of the flocculating/coagulating particles. Strength of aggregates will be measured by applying controlled shear. Flocs are expected to be much stronger than coagulase. The diffusion data from DLS measurements from primary colloids will be compared with a quantitative model for flocculation developed earlier by Ansari and Hallett¹³ to yield important information on the particle-particle, particle-polymer, and polymer-polymer interactions in a flocculating system.

In case of microscopic particles ($>1 \mu\text{m}$), Earth's gravity plays a dominant role in promoting differential settling and hence flocculation. The separation of liquid-solid components in a microgravity environment by destabilizing a suspension would offer great technical challenges because of the absence of differential settling. Particles of different size or density settle at different rates and the resulting relative motion can cause particle collisions and hence aggregation. A better understanding of the flocculation process in a microgravity environment will be useful in obtaining successful separation process technology for space-based processing operations.

FAME Hardware Development

The design criteria of FAME hardware is to acquire a miniaturized DLS system having both launch and collection optics in one entity (probe), modular (satisfy the requirements of several experiments), user friendly, rugged yet flexible, power efficient, eliminate the use of an index matching fluid for flare control, eliminate the need for on-orbit optical alignment, and offer in-situ sample mixing capabilities. In order to gain detailed knowledge in the theory and practice of DLS, the interested reader is referred to general reading in this area¹⁴⁻¹⁶ and the references contained therein.

The experimental setup shown in Figure 1 comprises four major parts; the laser/detector module, a fiber optic backscatter probe, the flocculation module (sample chambers with mixing motor), and a correlator hardware/software. This experiment module with a dimension of 21.2 cm wide x 12.8 cm deep x 19.0 cm high can be easily seated on its

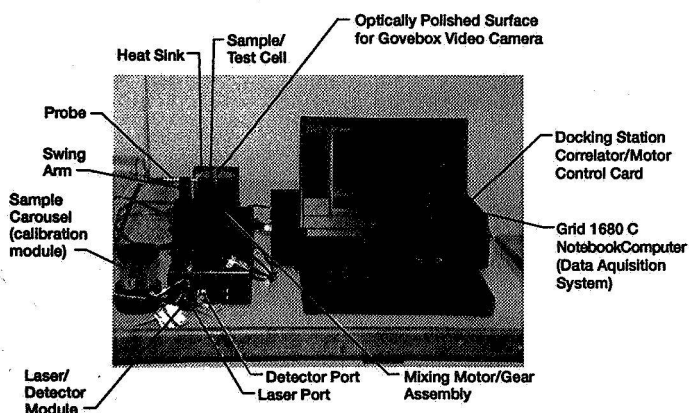

Figure 1. Experimental Setup.

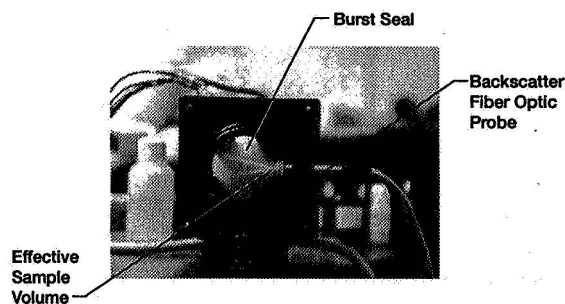

Figure 2. Effective Scattering Volume as Shown by Two Intersecting Laser Beams in the Flocculation Cell.

magnetic legs inside the GBX. The GBX working area is 39.4 cm wide x 27.9 cm deep x 23.5 cm high with one main door opening of 21.4 cm x 18.9 cm and two side door openings 21.4 cm x 13.1 cm.

The laser light out of the laser/detector module is transmitted by a compact backscatter fiber optic probe to the flocculation module, where the flocculation process of a particulate dispersion is observed. A lens-less fiber optic probe comprising two optical fibers, as illustrated in Figure 2, provides a compact and remote means of studying the dynamical characteristics of colloidal/polymer systems, through the use of photon correlation spectroscopy or dynamic light scattering. Detailed descriptions of the backscatter fiber optic probe and its application to study concentrated particulate dispersions¹⁷, microemulsion characterization¹⁸, the early detection of cataracts in bovine and human eye lenses¹⁹⁻²¹, and BSA and lysozyme protein solution characterization have been reported elsewhere²².

Experimental

A simplified cross sectional view of the flocculation module is shown in Figure 3. The flocculation module consists of 3 major units; the base, the sample cell, and the swing arm. The sample cell is divided into 2 sections by a piston to contain the particle solution on the top section and the polymer solution on the bottom. The cell holds about 100 ml of sample volume. The sample cell has a thin sapphire window where the backscatter fiber optic probe is positioned so that the scattering volume is effectively located well inside the sample cell. The base module contains a stepper motor and its driver. The chopper driver's heat dissipation fins are connected to the base module which acts as a heat sink for the motor. The stepper motor is connected to the piston in the sample cell by a gear set. The piston has a hole that is covered by a thin aluminum bursting seal, and 3 stirring wings attached on top. The base of the piston divides the sample cell into two chambers. The upper and lower chambers are filled with the aqueous particle dispersion

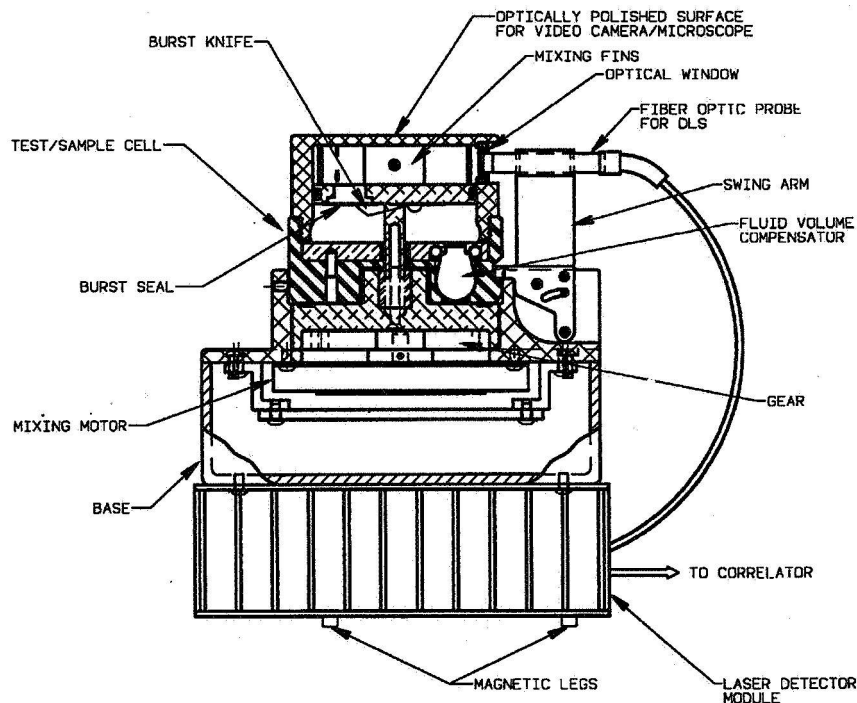

Figure 3. FAME Experiment Module.

and the long chain polymer solution respectively, through the fill holes located on the side of these chambers. The sample loading is done very carefully to ensure dust free and bubble free samples. During the experiment the piston retracts (pulls downward) in the sample cell by the stepper motor gear assembly. The bursting seal punctures upon contact with a knife edge mechanism and the polymer solution comes into contact with the particle solution. After the piston is completely pulled down and locked to the motor, it starts spinning, and the stirring action begins with three wing tips, each measuring 12 mm x 21 mm x 1 mm, on the top of the piston assembly. The spinning or mixing speeds can be varied from 5 rpm to 700 rpm. This spinning action is desired for two purposes. First it enables complete mixing of the two dispersions and secondly to study the effects of agitation and controlled shear on flocculation. The swing arm holds the fiber optic backscatter probe against the sapphire window of the sample cell. It can swing back and forth around a pivot point on the base module so that the sample modules can easily be exchanged without pulling out the probe every time a new measurement is performed. Another purpose of the swing arm is that when in position, the arm locks the sample cell with the base so that the sapphire window stays well aligned with the backscatter probe. This arrangement provides an easy access, safety, and flexibility to the crew member during experimental procedures. The test chambers are made of polycarbonate material with an optically polished flat surface on the top for studying in-situ the dynamics of the suspension (particles $\gg 30 \mu\text{m}$) under investigation using the GBX video camera or the microscope.

Results

The FAME engineering model was tested on aqueous samples of polystyrene latex spherical colloidal particles ranging in size from 18 nm to 551 nm (Bangs Laboratory, Carmel, IN) at a concentration of 0.01%. The upper chamber of the test cell was filled with this dispersion and the lower chamber was filled with doubly distilled deionized water. The fiber optic probe provided measurements of particle size prior to mixing with water in the upper chamber and then after mixing with pure water in the lower chamber. These measurements are reported in Figure 4. The mean average diffusion coefficient, mean average size, and corresponding dimensionless polydispersity factor (PDF) computed from fifty autocorrelation functions for each particle dispersion are tabulated in Table 1. The average translational diffusion coefficient (D_T) and PDF are determined by analyzing the intensity-intensity autocorrelation data using the method of cumulants²³. The D_T values are converted to average size (diameter) using the Stokes-Einstein equation¹⁴⁻¹⁶. PDF is a sensitive measure of the sample's polydispersity i.e. smaller the PDF, narrower the size distribution. Table 1 consistently shows very small values of PDF as expected from monodisperse samples. The fiber optic probe provides high precision particle size measurements within 5-15 seconds. 15, 60, and 300 seconds duration measurements give consistent values of particle sizes within 1-3%.

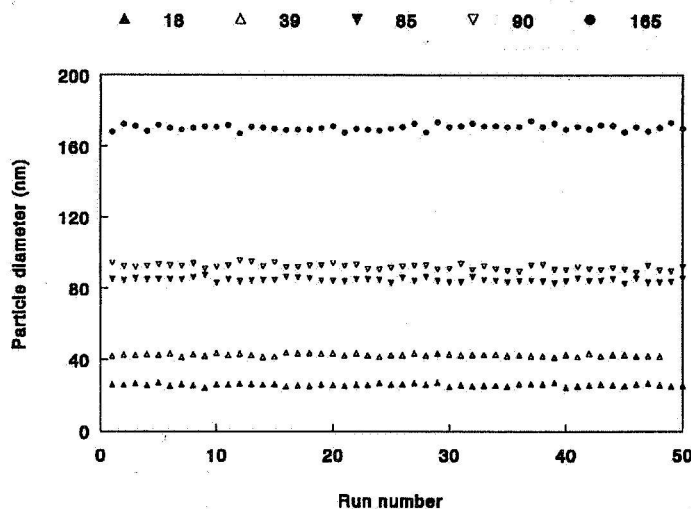

Figure 4. Particle Size Test Results.

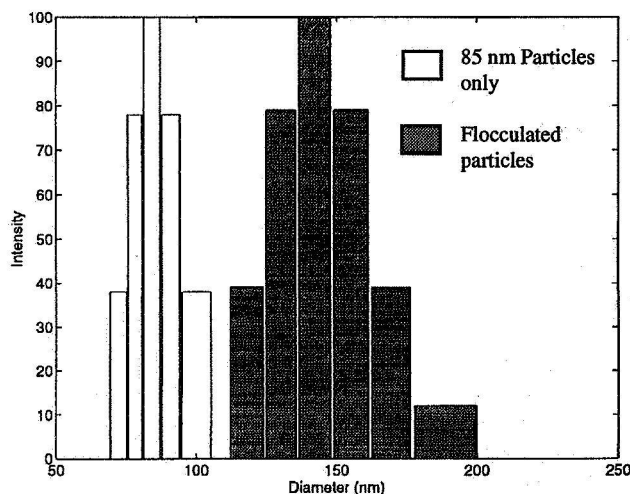

Figure 5. Particle Size Distribution with and without Polymer Aided Flocculation.

TABLE 1. FAME ENGINEERING MODEL PRELIMINARY TEST RESULTS

Sample, Aqueous Dispersions of Polystyrene Standards (nm)	Diffusion Coefficient. m^2sec^{-1} (10^{-13})	Mean Diameter nm	Polydispersity Factor PDF
18	169.12±4.21	25.36±0.64(5 sec. runs)	0.0016
39	104.36±1.73	42.55±0.70 (15 sec. runs)	0.0047
85±4	53.23±0.64	85.87±1.66 (15 sec. runs)	0.00026
85 nm particles mixed with polymer (Flocculated)	92.38±3.90	119.70±4.70 (15 sec. runs)	0.02180
90	47.72±0.78	92.15±1.69 (15 sec. runs)	0.00125
	47.68±1.63	92.33±2.80 (5 sec. runs)	0.00109
165±3	26.95±0.32	171.52±1.99 (5 sec. runs)	0.0005
551±10	9.24±0.39	517.96±21.34 (15 sec. runs)	0.00013

Preliminary flocculation tests were conducted using a long-chain, high molecular weight (≈ 6 million daltons), polyacrylamide polymer and polystyrene spherical particles. The freely diffusing polymer chains in the polymer solution contributes only negligibly ($<5\%$) to the total light scattering intensity at a concentration of about 50 ppm (parts per million). At this low polymer concentration the viscosity of the solution remains very closely to that of pure water. All measurements were conducted at room temperature. As an example, flocculation test results on 85 nm particles of polystyrene are reported here. In these experiments the two chambers were cleaned, and burst seals were replaced. The upper chamber was filled with the 85 nm particle dispersion while the lower chamber was filled with a polymer solution. DLS measurements were repeated. The size distribution of the polystyrene particles in the upper chamber is presented in a histogram (see Figure 5). The burst seals were broken to let particle and polymer molecules combine. After few minutes of mixing the particles grew in size and appeared to form flocs. NNLS²⁴ (non negative least squares) program from the commercially available software (Brookhaven Instrument Corporation, NY) is used to recover particle size distribution. Clearly the narrow size distribution of the 85 nm monodisperse particles is broadened (shaded area in Figure 5) due to polymer aided flocculation. This can also be seen from the changes in PDF values (see Table 1). This factor increases by two orders of magnitude. This indicates clustering of 85 nm monodisperse particles into bigger aggregates (flocs). More data is being gathered at this time using the FAME engineering model involving different particle sizes as a function of polymer molecular weight (chain size), the particle and polymer concentrations and the electric charge on their surfaces. This will be reported at a later date. The detailed studies of flocculation, however, will ultimately require μg conditions in which bigger floc behavior will be monitored without the detrimental effects of sedimentation and convection.

Figure 6 shows flocs or aggregates of 260 nm polystyrene spherical particles at a concentration of $1 \times 10^{-5} gcm^{-3}$ using PAM solution of molecular weight 5×10^6 at a concentration of 100 ppm. These very dilute dispersions were mixed in a cuvette by hand shaking and electron micrographs were taken after few hours. Various shapes of aggregates are evident. The pioneering work by Weitz and Oliveria²⁵ on aggregates of colloidal gold and Auburt and Cannell²⁶ on colloidal silica has established that aggregates can be treated as fractal objects. We plan to extend the fractal analogy to long-chain polymer induced flocculation. For this purpose a simultaneous multiangle light scattering ap-

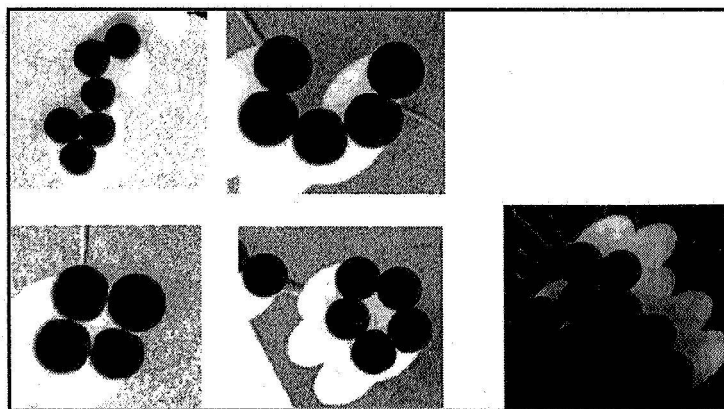

Figure 6. Floc Shapes.

paratus built by one of us (HSD) will soon be used to obtain dynamic and static light scattering data on a flocculating system. We hope to gain detailed information on the floc shape, its structure (open or compact), and the dynamics of floc formation. We are also looking into the polymeric networks, diffusion of particles through them at three regimes ($C < C^*$, $C = C^*$, and $C > C^*$; C^* is the critical concentration at which polymeric entangled networks become appreciable), and their effect on flocculation of these particles. The experiments reported here involve model polystyrene colloids. We plan to extend this work to clays, which are involved in majority of industrial flocculation operation in real world.

Conclusion

A compact functional engineering model built for a Glovebox experiment to study flocculation and aggregation phenomena in a microgravity environment, using the technique of dynamic light scattering, has been tested on the ground employing several colloidal dispersions of polystyrene latex particles ranging in size from 18 nm to 551 nm. One unique feature of the optical design is that both launch and collection optics are integrated into a miniaturized probe. With only 2.6 mW input laser power, this optical design matches or exceeds the efficiency of typical conventional DLS setups²⁰. Conventional DLS systems use at least one to two orders of magnitude more power and physically occupy a large volume (1 m³). The FAME system provides rapid measurements of diffusion coefficient and particle size in the backscatter regime (within 5-15 seconds), needs no optical alignment, and offers insitu sample mixing, controlled shear, and video monitoring capabilities (particles size $\gg 30$ microns). The preliminary data is very encouraging and has opened up new possibilities for gaining new insights into the process of flocculation. The system will be tested shortly on NASA's Lear Jet flights to check and simulate its functionality and ease of operation to actual flight conditions in a microgravity environment.

Acknowledgments

The NASA's Microgravity Sciences & Application Division (MSAD) and code UG's support for hardware development (Task # YOF 0176) is thankfully acknowledged. RRA would like to thank the GBX project team (especially Brian Quigley) at NASA Lewis Research Center and the Alpha Division of ADF (Aerospace Design & Fabrication of Cleveland, Ohio) for their design and fabrication efforts.

References

1. Ansari, R.R., Dhadwal, H.S., and Suh, K.I., "An Integrated Fiber Optic System for Dynamic Light-Scattering Measurements in Microgravity", Proceedings of The International Symposium on Space Optics 18-22 April 1994, Garmisch-Partenkirchen, FRG, EOS/SPIE Paper #2210-22.
2. Dutta, P.K., Jakupca, M., Salvati, L., Reddy, K.S.N., and Ansari, R.R., "Synthesis of Microporous Materials in Reverse Micelles", 32nd Aerospace Sciences Meeting & Exhibit, AIAA 94-0569, January 10-13, 1994, Reno, Nevada.
3. Attia, Y.A., (Editor), "Flocculation in Biotechnology and Separation Systems", Process Technology Proceedings, 4, Elsevier, 1987.
4. Finch, C. A., Editor, "Chemistry and Technology of Water Soluble Polymers," Plenum Press, New York 1983.
5. Gregory, J., "In the Scientific Basis of Flocculation", Ives, K. J., ed., NATO Adv. Study Inst. Series, Sijthoff and Noordhoff Alphen aan den Rijn, The Netherlands 1978.
6. Gregory, J., "Fundamentals of Flocculation", CRC Critical Reviews in Environmental Control, Vol. 19, Issue 3, pages 185-230 (1989).
7. Deryagin, B.V., and Landau, L.D., "Theory of the Stability of strongly lyophobic sols and of adhesion of strongly charged particles in solutions of Electrolytes", Acta Physicochim, URSS, 14, 633, 1941.
8. Verwey, E.J.W., and Overbeek, J. Th. G., Theory of the Stability of Lyophobic Colloids, Elsevier, Amsterdam, 1948.
9. Gregory, J., "Rates of Flocculation of Latex Particles by Cationic Polymers", J. Colloid Interface Sci., 42, 448, 1973.
10. Naumann, R.J., and Herring, H.W., "Materials Processing in Space: Early Experiments", NASA SP-433, p.26, 1980.
11. Sikora, M.D., and Stratton, R.A., "The Shear Stability of Flocculated Colloids", Tappi, J. 64(1981) p. 97-101.

12. Varoqui, R., and Pefferkorn, E., "Experimental and Theoretical Aspects on Cluster Size Distribution of Latex Particles Flocculating in Presence of Electrolytes and Water Soluble Polymers", *Prog. Colloid Polym. Sci.*, 79:194-201 (1989).
13. Ansari, R.R., and Hallett, F.R., "Quasi-Elastic Laser Light Scattering Study of Polymeric Flocculant Suspensions", in *Particulate and Multiphase Processes*, Vol. 3, Colloid and Interfacial Phenomena, T. Ariman and T.N. Veziroglu, Editors, Springer-Verlag, 1985.
14. Chu, B., "Laser Light Scattering: Basic Principles and Practice", Academic Press, New York, 1991.
15. Schmitz, K.S., "An Introduction to Dynamic Light Scattering by Macromolecules", Academic Press, 1990.
16. Pecora, R, Editor, "Dynamic Light Scattering: Applications of Photon Correlation Spectroscopy", Plenum Press, 1985.
17. Dhadwal, H.S., Ansari, R.R., Meyer, W.V., "A fiber Optic Probe for Particle Sizing in Concentrated Suspensions", *Rev. Sci. Instrum.* 62 (12), December 1991.
18. Ansari, R.R., Dhadwal, H.S., Cheung, H.M., and Meyer, W.V., "Microemulsion Characterization by the use of a Noninvasive Backscatter Fiber Optic Probe", *J. App. Optics*, Vol. 32, No. 21, July 1993.
19. Ansari, R.R., Dhadwal, H.S., Campbell, M.C.W., and DellaVecchia, M.A., "A Fiber Optic Sensor for Ophthalmic Refractive Diagnostics", *Proc. of Fiber Optic Medical and Fluorescent Sensors and Applications*, January 23-24, 1992, Los Angeles, CA., SPIE Vol. 1648.
20. Ansari, R.R., and Dhadwal, H.S., "A Fiber Optic Probe for the Detection of Cataracts", *The third National Technology Transfer Conference & Exposition*, December 1-3, 1992, Baltimore, MD., NASA conference Publication 3189, Vol. I.
21. Dhadwal, H.S., Ansari, R.R., DellaVecchia, M.A., "Coherent Fiber Optic Sensor for Early Detection of Cataractogenesis in a Human Eye Lens", *J. Opt. Engineering*, Vol. 32, No. 2, February 1993.
22. Dhadwal, H.S., Wilson, W.W., Ansari, R.R., and Meyer, W.V., "Dynamic Light Scattering Studies of BSA and Lysozyme Using a Backscatter Fiber Optic System", *Proc. of Static and Dynamic Light Scattering in Medicine and Biology*, 21-22 January, 1993, Los Angeles, CA, SPIE Vol. 1884.
23. Koppel, D.E., "Analysis of Macromolecular Dispersity in Intensity Correlation Spectroscopy: The Method of Cumulants", *J. Chem. Phys.*, Vol. 57, 4814-4820, 1972.
24. Lawson, C.L., and Hanson, R.J., "Solving Least Squares Problems", Prentice Hall, 1974.
25. Weitz, D.A., and Olivera, M., "Fractal Structures Formed by Kinetic Aggregation of Aqueous Gold Colloids", *Phys. Rev. Lett.*, 52, 1433, 1984.
26. Aubert, C. and Cannell, D.S., "Restructuring of Colloidal Silica Aggregates", *Phys. Rev. Lett.*, 56, 738, 1986.