

110175

2/745
P. 8

The GRO Remote Terminal System

David J. Zillig (NASA/GSFC/Code 531.2)

Joe Valvano (AlliedSignal Technical Services Corporation)

ABSTRACT

In March 1992, NASA HQ challenged GSFC/Code 531 to propose a fast, low-cost approach to close the Tracking Data Relay Satellite System (TDRSS) Zone-of-Exclusion (ZOE) over the Indian Ocean in order to provide global communications coverage for the Compton Gamma Ray Observatory (GRO) spacecraft. GRO had lost its tape recording capability which limited its valuable science data return to real-time contacts with the TDRS-E and TDRS-W synchronous data relay satellites, yielding only approximately 62% of the possible data obtainable. To achieve global coverage, a TDRS spacecraft would have to be moved over the Indian Ocean out of line-of-sight control of White Sands Ground Terminal (WSGT). To minimize operations life cycle costs, Headquarters also set a goal for remote control, from the WSGT, of the overseas ground station which was required for direct communications with TDRS-1.

On August 27, 1992, Code 531 was given the go-ahead to implement the proposed GRO Relay Terminal System (GRTS). This paper describes the Remote Ground Relay Terminal (RGRT) which went operational at the Canberra Deep Space Communications Complex (CDSCC) in Canberra, Australia in December 1993 and is currently augmenting the TDRSS constellation in returning between 80-100% of GRO science data under the control of a single operator at WSGT.

INTRODUCTION

The GRO Remote Terminal System (GRTS) was implemented in a fast-paced, low-cost effort to close the gap in TDRSS coverage over the Indian Ocean to increase the science data return from the GRO spacecraft. To cover the ZOE, which is caused by earth-blockage of the 2-TDRS constellation, the oldest TDRS spacecraft, TDRS-1, was drifted to 85 degrees east longitude. At that location it could provide the additional coverage for GRO but, as a result, was out of line-of-sight communications with WSGT. To provide control and monitoring of the TDRS and to return the data relayed from GRO to the US, two new nodes (connected by Intelsat links) were required to be

added to the Space Network, one at WSGT in New Mexico and the other at the new overseas relay site in Australia. Figure 1 provides an overview of the GRO Remote Terminal System.

The node at WSGT, named the Extended TDRSS Ground Terminal (ETGT) retains all the command and telemetry processing and unique software for TDRS-1, the spacecraft controller personnel and the interfaces to GSFC for GRO data, the NCC and FDF. As with the other TDRS spacecraft, complete control remains at WSGT/ETGT. In this case, however, control is exercised via redundant NASCOM 64 kb/s Intelsat links to the RGRT at CDSCC in Australia.

The node at CDSCC, RGRT, emulates (at a much reduced scale) the ground terminal equipment at WSGT (the antennas, receivers, transmitters and computer controls). The commands are received by commercial carrier from ETGT and then transmitted from RGRT up to TDRS-1 and the status telemetry is downlinked from TDRS-1 to RTGT and then relayed back to ETGT via Intelsat. Range and Doppler measurements for TDRS orbit determination are made at the RGRT and then communicated through WSGT to the Flight Dynamics Facility at GSFC.

Science data from GRO's onboard instruments is collected and radiated at 32 Kb/s in spread spectrum S-Band mode to TDRS-1 located at 85 degrees east longitude. TDRS-1 receives the signal using either the 30-element phased array Multiple Access (MA) antenna or the 4.9 m S-Band Single Access (SSA) dish antenna. The S-Band return link from GRO is translated to Ku-Band onboard TDRS and transmitted to the ground at RGRT via the TDRS Space to Ground Link (SGL) antenna. The 32 kb/s data is received by either the MA or SSA receiving equipment, despread, demodulated and transmitted in real time via Intelsat to ETGT and then on to the GRO POCC.

Since the GRO POCC has ample opportunity for spacecraft commanding through the TDRS-E and TDRS-W, only return link user services are incorporated in the RGRT design.

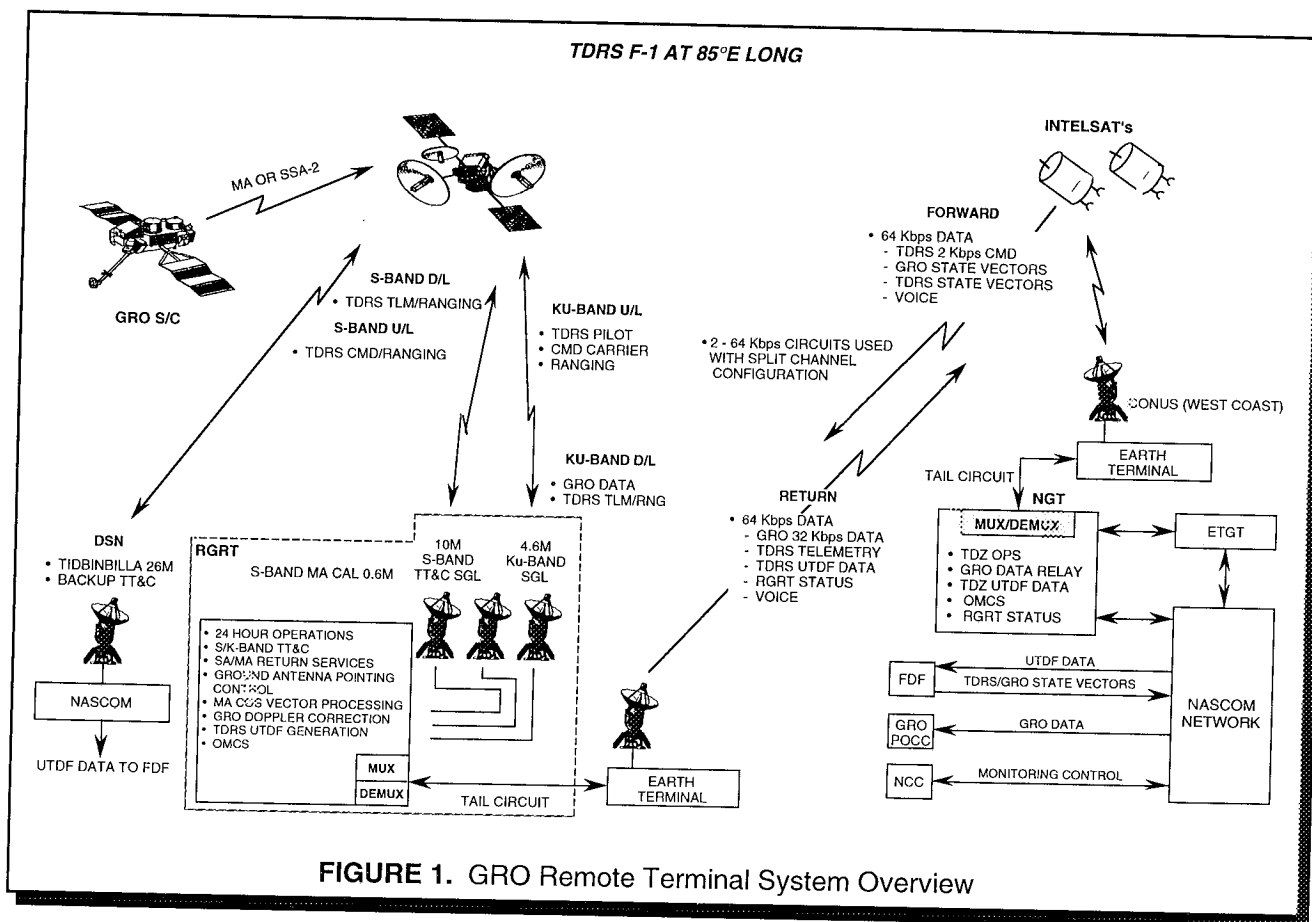

RGRT IMPLEMENTATION - OVERVIEW

Since no equipment from the WSGT or Second TDRSS Ground Terminal (STGT) could be made available for this implementation, the system design relied on a mixture of commercial off-the-shelf (COTS) and GSFC custom designed equipment (both in-house and contractor-designed).

The RGRT design, like WSGT, is essentially two ground terminals in one - the TDRS TT&C system to control and monitor the TDRS and the User Service system to receive the science data from GRO.

The critical TDRS TT&C function was implemented using proven Ground Network (GN) receiver/exciter/ranging (RER) equipment - the same equipment used in the GN and the DSN 26 meter subnet for TDRS launch support and on-orbit TT&C backup. Redundant receivers and exciters and a single ranging equipment, switchable to either the S-Band or Ku-Band systems were used.

The User Service system was a more difficult problem because it required specialized TDRSS

beamformers, spread spectrum receivers and associated equipment. Fortunately, the STGT Project had just successfully developed and tested a new-generation multiple access beamformer. As a result, a subset of that equipment, modified for use at RGRT, was able to be procured from the same manufacturer in a timely fashion. The spread spectrum receiver used in both the SSA and MA systems was adapted from a recent GSFC in-house development - the TDRSS User RF Test Set (TURFTS). TURFTS was designed by Code 530 for use in TDRSS user transponder testing in the laboratory and for spacecraft project integration and test. Its design incorporates recent technology such as custom VLSI PN generator chips, numerically controlled oscillators (NCO's) for frequency generation and a digital signal processor (DSP)-based receiver. For use at RGRT, the TURFTS receiver sensitivity was improved and the controller software was modified to control a redundant set of hardware and to allow remote operation from WSGT. The transmitter portion of TURFTS was also adapted to provide the spread spectrum signal transmitted to TDRS at S-Band for MA beamformer calibration.

AlliedSignal Technical Services Corporation (ATSC), the principal technical support contractor for the GRTS Project, also designed a number of critical items of hardware and software essential to the implementation of the RGRT. These included the TT&C and User Service Processors, the Test Inject and Range Zeroset systems, the OMCS application software and components in the Common Time and Frequency Subsystem.

The third category of equipment, which filled in missing items in both the TT&C and User Service systems, was Commercial-off-the-shelf hardware and software. These were items available as "standard products" from manufacturers and included the 10-meter S-Band and 4.6-meter Ku-Band antennas and high power amplifiers, upconverters, downconverters, bit synchronizers, numerous rack-mounted PC's, monitor & control software, pilot signal generators, test equipment and many other items essential to the success of the project.

The critical procurement process of these items was handled by the Raytheon Service Company (RSC) as procurement agent to the government with GSFC/Code 530, supported by ATSC, providing technical oversight. The entire procurement process including specifications, solicitation and negotiation was completed by January 1993 - five months after project start. A 120-day delivery requirement was imposed on most of the vendors and critical long-lead components were incentivized to ensure on-time delivery. Monthly meetings were held at the plants of the more critical vendors for early detection and correction of technical and schedule problems.

RSC also developed an aggressive transportation strategy with a goal of 168 hours of transit time from the vendor's dock to CDSCC in Australia. Due to the excellent execution of the logistical planning and coordination between GSFC, RSC, ATSC and CDSCC, the transportation goal was achieved for about 95% of the 434 pieces/53 tons of equipment shipped, with essentially no damage enroute.

RGRT DETAILED DESIGN

The RGRT design philosophy was driven by the goal to deploy the station rapidly while keeping the costs reasonable. The need for rapid deployment forced the design to be modular, robust, and

conservative. The requirements were decomposed according to engineering disciplines and tasked to small design teams for execution. Another small group of system engineers was responsible for the overall architecture and insuring coordination between design teams.

All of the senior members of the design teams and many of the design engineers had extensive experience working with the GN, WSGT, or STGT. Many of the design decisions reflect lessons learned working with these programs.

The decision to locate the site at the Canberra Deep Space Communications Complex (CDSCC) saved approximately 6 to 12 months over development of a new site. CDSCC was chosen because it already had 60 Hz power, an available building, in-place NASA logistics, a NASCOM node, and personnel already familiar with some of the NASA equipment used at RGRT, while providing only 2 percent less GRO data when compared to a geometrically optimized site location over the Indian Ocean region.

The following station architecture decisions and system design guidelines were decided early and used throughout the project:

- The RGRT would be a remote front end for the White Sands Ground Terminal (WSGT). No command and telemetry data processing would be done at RGRT.
- Separate S and Ku-band antennas would be used to help make the station more robust.
- The design would minimize maintenance and operational personnel demands.
- Preference would be given to using equipment currently in NASA inventory
- Use of new designs was discouraged.
- Use of commercial-off-the-shelf (COTS) products was encouraged especially for equipment with a proven track record.
- The station design would incorporate redundant strings of equipment for TDRS command, TDRS telemetry, and GRO telemetry.
- The Operations Monitor and Control Subsystem (OMCS) would only do monitor and control. Other computationally intensive functions (such as ephemeris propagation, etc.) would be done by special purpose processors.

- The special purpose processors would use a common rack-mountable PC design.
- All equipment would have front panel or some type of local control for operation independent of the OMCS.
- Special attention would be given to avoiding self inflicted EMI and EMI with the CDSCC deep space communications activities.

Although many components required reconfiguration or minor modifications to support the RGRT mission, there were no new designs. NASA and contractor engineers worked very closely with the COTS vendors to insure that the technical requirements and delivery schedule were met. In many cases, monthly visits to vendors' plants were necessary during the development phase.

It was not possible to do full-up laboratory testing before the system was deployed to the field. All interfaces and specifications, however, were tested either in the lab or at the factory before shipment using specially configured test fixtures where necessary.

Almost all of the lead engineers responsible for the various subsystems and components traveled to the site to insure successful integration. Some surprises were found during integration, but these were primarily software related and mostly in the area of remote monitor and control. The monitor and control problems were mitigated by designing all of the components with front panel or local controls that could operate without the Operations Monitor and Control Subsystem (OMCS). This allowed the station's RF and data circuits to be tested independent of the OMCS. OMCS capabilities then incrementally came on line as the bugs were worked out.

The 16 hour time difference between CDSCC and the east coast of the US essentially forced split shifts between the integrators on-site and the supporting engineers in the GSFC area. This was used to advantage during software testing. The integrators tested software during the day shift in Australia and Emailed discrepancy reports back to the developers. The developers then made software updates during their day shift and put them on a file server. The next day, the integrators would get the updates from the server via Internet and load them on the target machines on site and

repeat the cycle. Good electronic data communications made this cycle very efficient.

Electromagnetic Interference (EMI) was also a major design concern. There was concern with both self inflicted RGRT EMI and the RGRT causing EMI to the sensitive deep space communications station at CDSCC. Because of the schedule, a detailed EMI analysis was not done. Instead, each subsystem was designed to minimize stray emissions and EMI shielding equipment racks were procured. The following steps were taken to minimize EMI:

- The high power amplifiers were located in shelters near the RGRT antennas and away from the main equipment room.
- Fiber optic connections were used for monitor and control and data communications between buildings wherever possible.
- NASA grounding specifications were rigorously applied.
- The TDRS Multiple Access Calibration Source was located approximately 2km away from the main site where there was no direct line-of-site to any of the DSN antennas.
- The MA Cal source is not scheduled to be used during any sensitive DSN S-band support periods.
- Equipment chassis suspected to having mutual interference problems were packaged in different racks.
- Racks with RF gaskets were used.
- Intermediate bars and RF gaskets for use between drawers in racks were procured, but were not used because the individual chassis were found to be sufficiently shielded.
- An extensive RF survey was performed.

Because of these steps, no major EMI problems were encountered during the implementation.

The RGRT has five major subsystems: the Antenna Subsystem, the TT&C Subsystem, the User Service Subsystem, the Common Time and Frequency Subsystem, and the Operations Monitor and Control Subsystem (See Figure 2 - RGRT Block Diagram). The salient features of each subsystem are discussed in the following paragraphs. The Common Carrier/Data Interface System, al-

FIGURE 2. RGRT Block Diagram

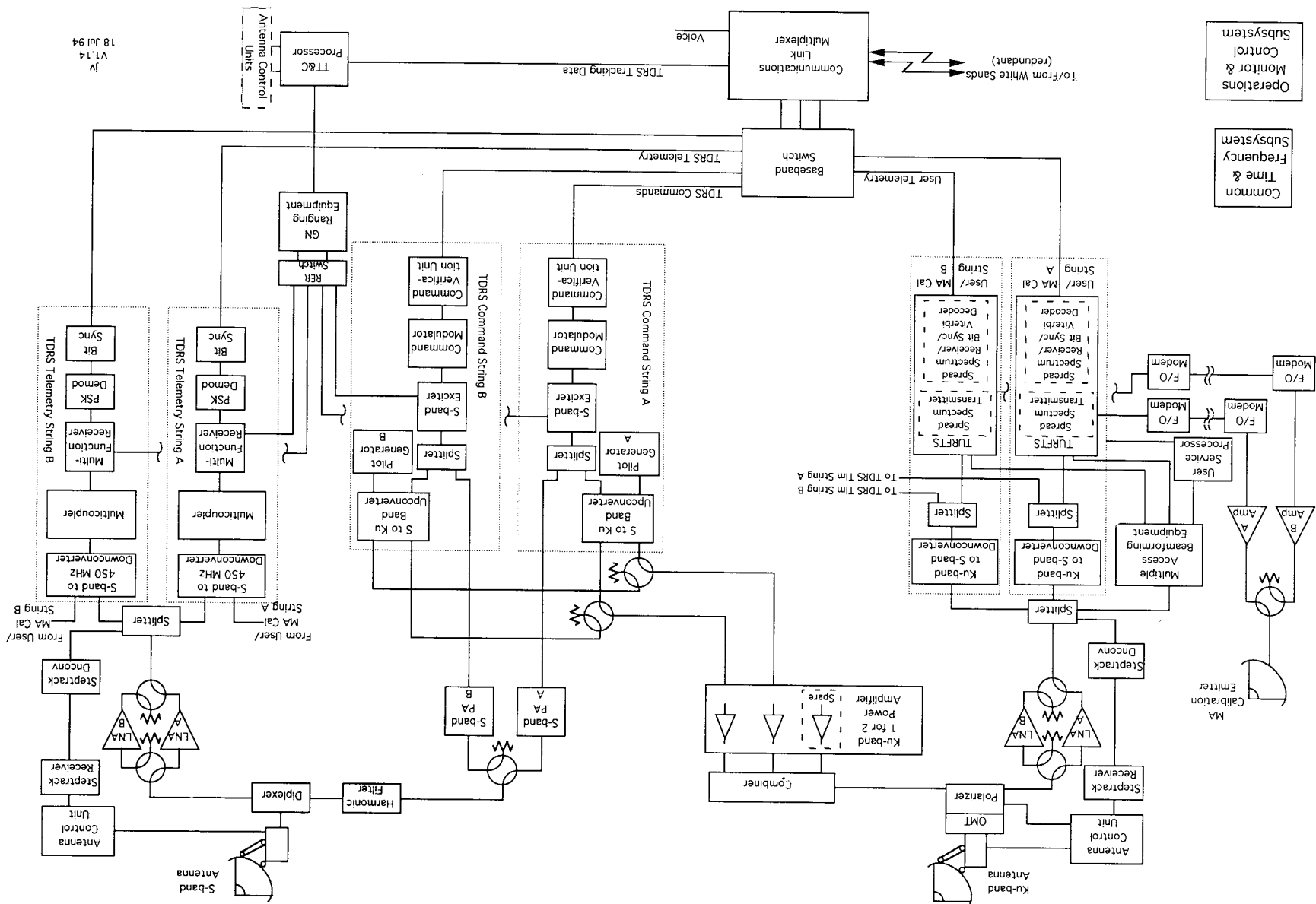

18 Jul 94
JV
V1.14

though not technically part of the RGRT is also discussed below.

ANTENNA SUBSYSTEM

The Antenna Subsystem consists of the antennas, antenna controls, transmitters, and associated microwave circuitry. The RGRT has three antennas: the S-band antenna, the Ku-band antenna, and the Multiple Access Calibration (MA Cal) antenna. The S- and Ku-band antennas are used to support the TDRS space-to-ground links, while the MA Cal antenna is used periodically to calibrate the Multiple Access phased array antenna onboard the TDRS.

The S-band antenna is used to support command, telemetry, and ranging via the omnidirectional antenna on the TDRS. It provides a robust RF link and may be used regardless of the TDRS attitude. The S-band antenna uses a standard communications satellite limited-motion mount equipped with a 10 meter reflector and a single horn prime focus feed. TDRS-1's orbit currently has a 7.7 degree inclination, so the antenna moves substantially to cover the satellite's diurnal motion. Typically the antenna operates in program track mode. The pointing angles are computed by the TT&C processor. The mount, controls, reflector, feed, and microwave components, with the exception of the diplexer, are COTS products procured as a system from a single vendor. In order to meet the schedule, NASA furnished the manufacturer with an excess diplexer for incorporation into the delivered product.

The Ku-band antenna is used to support TDRS command, telemetry, and ranging via the SGL dish antenna on the TDRS. It is also used to uplink the pilot signal and receive the GRO return link data. It also has a limited-motion mount and has a 4.6 meter dish with Gregorian geometry. The mount, controls, reflectors, and microwave components are standard COTS items. The feed is also a COTS item that was re-tuned to operate in the TDRS Ku-band. The entire Ku-band antenna system was procured from a single vendor. It operates in a manner identical to the S-band antenna.

Both the S- and Ku-band antennas have identical azimuth coverage. The limited-motion mounts cover 180 degrees of azimuth in three overlapping sectors. This capability allowed these antennas to support the TDRS drift from 171 degrees west longitude to its present position of 85 degrees east longitude.

The decision to have two antennas rather than a single, dual-band antenna was made because this configuration inherently provides redundancy and two antennas had a faster delivery time. Two different manufacturers were used in order to spread the risk of late deliveries. As it turned out, both vendors were about a week behind the 120 day delivery schedule and either would have had a significant problem producing both antennas simultaneously.

TRACKING, TELEMETRY, AND COMMAND (TT&C) SUBSYSTEM

The TT&C Subsystem is responsible for handling the TDRS command and telemetry data. It also includes the equipment for generating the pilot signal and measuring the TDRS two-way range and Doppler. The TT&C Subsystem was built around a spare Receiver/Exciter/Ranging (RER) System identical to those used at the NASA Ground Network sites. Up- and downconverters are used to operate the S-band RER at Ku-band. New test inject and range-zero-set electronics were developed for RGRT, but incorporated COTS signal generators in the design.

The pilot signal is an unmodulated signal that together with the command uplink carrier is used by the TDRS on-board Master Frequency Generator to derive all of the local oscillator signals used by the TDRS user service RF processors. The pilot generators are COTS signal generators operating at S-band. A two-channel upconverter with a common local oscillator (LO) is used to upconvert the S-band command and pilot signals to Ku-band. The use of a common LO helps the RGRT meet the stringent TDRS phase noise specifications.

The TT&C processor is a special purpose PC that propagates the TDRS ephemeris data, interfaces with the COTS antenna controllers, and keeps the antennas on point. It also interfaces with the Ranging Equipment and generates tracking data that is used for TDRS-1 navigation. The ephemeris data processing and tracking data generation software are repackaged versions that were used on other GSFC projects.

The Command Verification Units (CVUs) are also special purpose PCs that verify that the TDRS command spacecraft address and parity bit are correct. The units insert an idle pattern for commands that

fail the simple verification tests and also keep command statistics. The CVU code was developed specifically for the RGRT application.

USER SERVICE SUBSYSTEM

The User Service Subsystem is responsible for receiving and demodulating the GRO data that is relayed through the TDRS. Only S-band Single Access and Multiple Access return link services are implemented at RGRT at this time.

The User Service Subsystem is built around the TDRS User RF Test Set. The TURFTS was originally developed by GSFC to test user transponders. The dual unit designed for RGRT includes two TDRS compatible spread spectrum receivers and transmitters. TURFTS firmware modifications were needed to meet RGRT mission requirements. Use of the TURFTS was the fastest and easiest way to get RGRT user service on-line. The TURFTS receiver is used to demodulate and decode the GRO data and the TURFTS transmitter is used to generate the test signal for TDRS multiple access phased array calibration.

The Multiple Access Beamforming Equipment (MABE) is used to steer the TDRS multiple access phased array for Multiple Access user support. RGRT uses a scaled-down version of the second generation MABE that was originally developed for the Second TDRS Ground Terminal program. The RGRT MABE only has two user channels while the STGT version has six. Two user channels allow for simultaneous GRO support and MA Calibration.

The User Service Processor (USP) propagates the TDRS and GRO ephemeris data. It provides direction cosines to the MABE for TDRS phased array steering and predicted Doppler data to the TURFTS for signal acquisition. The USP runs the identical ephemeris data propagation algorithm as the TT&C Processor.

OPERATIONS MONITOR AND CONTROL SUBSYSTEM

The RGRT Operations Monitor and Control Subsystem (OMCS) design capitalized on trade studies and market surveys completed by the GSFC Automated Ground Network Systems (AGNS) project some months earlier. The COTS monitor

and control system product selected was originally designed for applications such as chemical processing plant control and electrical power grid management. The choice to use a COTS monitor and control system allowed the designers to concentrate on the RGRT application rather than the OMCS infrastructure.

The COTS system is based on the use of industry standards, for example, POSIX compliant workstations are used for the operator interfaces, TCP/IP is used for interprocessor communications, and dBase IV is used for data base management. System utilities include graphical screen generation tools and device drivers.

The RGRT OMCS architecture consists of I/O Controllers and a workstation located in the RGRT equipment area, a workstation located at the CDSCC Signal Processing Center, two workstations at White Sands, and a workstation at the Network Control Center (NCC) at GSFC. All of the processing elements are connected via ethernet and COTS routers are used to connect the geographically dispersed LAN segments.

During RGRT installation, portions of the OMCS LAN were connected to the Internet for remote troubleshooting by the COTS vendor and engineers in the GSFC area. This proved to be very valuable. Now that RGRT is operational, there is no Internet connectivity because of security concerns. Software upgrade deliveries are done via the workstation at the NCC.

Additional information about the OMCS may be found in the SpaceOps '94 paper "GRTS Operations Monitor/Control System."

COMMON CARRIER/DATA INTERFACE SYSTEM

The Common Carrier/Data Interface System (CC/DIS) connects the RGRT in Australia to the TDRS data processing equipment in White Sands, New Mexico. The CC/DIS consists of COTS communications multiplexers and two 64 kb/s leased commercial communications lines. The 64 kb/s lines are physically diverse. They are leased from different companies and travel through different Intelsats.

The following data channels are multiplexed through the CC/DIS: 2 kb/s TDRS command data,

1 kb/s TDRS telemetry data, 32 kb/s GRO telemetry data, 12 kb/s RGRT monitor and control data, 110 b/s TDRS tracking data, and 6 kb/s digitized voice. The CC/DIS equipment is capable of multiplexing all of these channels onto a single 64 kb/s line, but typically they are divided with some channels on one 64 kb/s line and the remainder on the other. This provides faster failover time should one of the 64 kb/s lines fault.

CONCLUSIONS

The GRTS Project demonstrates NASA/GSFC's ability to quickly meet new spacecraft data acquisition and tracking challenges in a cost effective manner by inserting new technology and adapting exist-

ing space- and ground-based assets augmented with commercial off-the-shelf products.

The Space Network's communications support to GRO also illustrates one of the unique advantages of the synchronous Tracking Data Relay Satellite System. With the addition of GRTS, the now-global TDRS System is able to provide constant communications coverage for contingency support to NASA missions.

REFERENCES

Stocklin, F., (March 1994). The GRO Remote Terminal System - An Experience of a Lifetime. NASA Mission Operations and Data Systems Newsletter, Vol. 10, No.2

Data Management

2. Data Handling

Page 83

DM.2.a	Overview on METEOSAT Geometrical Image Data Processing <i>Frank J. Diekmann</i>	85-93 -10
DM.2.b *	UARS CDHF Conversion to DEC AXP Platform <i>Stuart Frye</i>	95 -11
DM.2.c	Use of a Multimission System for Cost Effective Support of Planetary Science Data Processing <i>William B. Green</i>	97-103 -11
DM.2.d	A Second Generation 50 Mbps VLSI Level Zero Processing System Prototype <i>Jonathan C. Harris, Jeff Shi, Nick Speciale, Toby Bennett</i>	105-115 -12
DM.2.e	A Corporate Memory for the GSFC Mission Operations Division <i>Beryl Hosack</i>	117 -11
DM.2.f *	Fast Computational Scheme of Image Compression for 32-bit Microprocessors <i>Leonid Kasperovich</i>	119-123 -13
DM.2.g	The Development and Operation of the International Solar-Terrestrial Physics Central Data Handling Facility <i>Kenneth Lehtonen</i>	125-132 -14
DM.2.h	Economical Ground Data Delivery <i>Richard W. Markley, Russell H. Byrne, Daniel E. Bromberg</i>	133-138 -15
DM.2.i	NASA Johnson Space Center Life Sciences Data System <i>Hasan Rahman, Jeffery Cardenas</i>	139-147 -16
DM.2.j	A Processing Centre for the CNES CE-GPS Experimentation <i>Norbert Suard, Jean-Claude Durand</i>	149-154 -17
DM.2.k	Single Stage Rocket Technology's Real Time Data System <i>Steven D. Voglewede</i>	155-168 -18
DM.2.l	International Data Transfer for Space Very Long Baseline Interferometry <i>Alexandria B. Wiercigroch</i>	169-175 -19
DM.2.m	ARACHNID: A Prototype Object-Oriented Database Tool for Distributed Systems <i>Herbert Younger, John O'Reilly, Bjorn Frogner</i>	177-183 -20

* Presented in Poster Session