

1102053
3/1975
p. 8

**MAGELLAN PROJECT:
Evolving Enhanced Operations Efficiency
to Maximize Science Value**

Allan R. Chevront
James C. Neuman
J. Franklin McKinney
Martin Marietta Astronautics
Denver, CO

ABSTRACT - Magellan has been one of NASA most successful spacecraft, returning more science data than all planetary spacecraft combined. The Magellan Spacecraft Team (SCT) has maximized the science return with innovative operational techniques to overcome anomalies and to perform activities for which the spacecraft was not designed. Commanding the spacecraft was originally time consuming because the standard development process was envisioned as manual tasks. The Program understood that reducing mission operations costs were essential for an extended mission. Management created an environment which encouraged automation of routine tasks, allowing staff reduction while maximizing the science data returned. Data analysis and trending, command preparation, and command reviews are some of the tasks that were automated. The SCT has accommodated personnel reductions by improving operations efficiency while returning the maximum science data possible.

MISSION OBJECTIVES - The objectives of the Magellan program were to place a spacecraft with a radar sensor in orbit around Venus; obtain, reduce, and analyze the scientific data from the planet and make these results available to the public and the scientific community. The Magellan scientific mission objectives were:

1. To improve the knowledge of the tectonics and geologic history of Venus by analysis of the surface morphology and the processes which control it.
2. To improve the knowledge of the geophysics of Venus, principally its density distribution and dynamics.
3. To improve the knowledge of the small scale surface physics.

The objectives of the science experiments were:

1. Imaging: To produce contiguous images of at least 70 percent (with a goal of 90 percent) of the surface of Venus with no

systematic gaps except for one pole, and with a surface radar resolution of at least 360 meters (surface radar resolution is defined as the distance between the 3dB points of the main lobe of the radar system impulse function).

2. Altimetry: To produce maps of the topographic and radar scattering characteristics of the planet Venus with height resolution commensurate with the Synthetic Aperture Radar (SAR) range resolution and coverage commensurate with the SAR coverage.
3. Gravity: To refine the low degree and order gravity field of Venus and to produce high resolution (several hundred kilometer horizontal scale) gravity maps wherever possible.

HISTORY - A single Magellan (MGN) spacecraft was launched from Kennedy Space Center Launch Complex 39B on May 4, 1989, on board the Shuttle Atlantis. The launch vehicle was a Shuttle Orbiter/Inertial Upper Stage (IUS) combination. Once in the shuttle parking orbit, the IUS and MGN spacecraft combination was deployed from the cargo bay. After the orbit coast period, the IUS injected the MGN spacecraft into an Earth-Venus transfer trajectory.

The MGN spacecraft is powered by two single degree-of-freedom, sun-tracking solar panels and is three-axis stabilized by reaction wheels using gyros and a star scanner for attitude reference. When launched, the spacecraft carried a solid rocket motor for Venus orbit insertion. A small hydrazine system was provided for trajectory correction and certain attitude control functions. Earth communications with the Deep Space Network (DSN) is by means of S- and X-band channels, operating via low- and medium-gain antennas and a 3.7 meter high-gain antenna dish which is rigidly attached to the spacecraft. The high-gain antenna also functioned as the Synthetic Aperture Radar (SAR) mapping antenna during orbital operations.

Magellan followed a Type IV interplanetary trajectory to Venus, which represents a transfer angle around the Sun of slightly greater than 540 degrees. The use of the Type IV trajectory was required by the orbit geometry of Earth and Venus for the May 1989 opportunity. The Type I trajectory opportunity in October 1989 had been allocated to Galileo for its Venus-Earth-Earth Gravity Assist trajectory to Jupiter.

The interplanetary cruise phase lasted approximately 15 months. Cruise activities included calibrations of the gyros, the attitude reference unit and the antennas, daily star calibrations, three trajectory correction maneuvers to insure proper approach geometry, a functional test of the radar subsystem, and a three-day test of the mapping capability.

MGN arrived at Venus on August 10, 1990. By firing the solid rocket motor slightly before Venus closest approach, the desired periapsis latitude near 10 degrees North was attained. The spacecraft was placed in an elliptical orbit around Venus with a period of 3.26 hours. The planned in-orbit checkout (IOC) period was cut short because a timing idiosyncrasy in the on-board Attitude and Articulation Control flight software caused the spacecraft to enter safing during the star calibration of the second test mapping orbit. The imaging data processed from the 1.5 test orbits prior to safing was of such high quality that the project decided to terminate IOC following the safing recovery and enter directly into mapping operations.

The prime mission (Cycle 1) began on September 15, 1990, and lasted 243 days, the time required for Venus to make one rotation under the spacecraft orbit. Cycle 2 started on May 15, 1991, and Cycle 3 started on January 15, 1992, and continued to September 15, 1992. Typical activities during the radar mapping orbits are shown in Figure 1. Mapping operations were halted after the third cycle due to a transmitter failure. The science emphasis shifted to the third science experiment, gravity data. Cycle 4 was devoted to collecting gravity data and planning for aerobraking operations.

Following Cycle 4, Magellan's periapsis was lowered to place the spacecraft in the atmosphere each periapsis pass in order to slow the spacecraft and nearly circularize the orbit. Magellan was the first planetary spacecraft to use aerobraking to change its orbit. Since aerobraking had not been

accomplished before and the spacecraft was not designed to aerobrake, the planning tasks broke new ground. Aerobraking was successfully accomplished in seventy days (planned for eighty) and placed the spacecraft into a 500 km by 200 km orbit. Cycles 5 and 6 have collected high resolution gravity giving scientist their first view of the subsurface at the poles. In Cycle 5 and 6, Magellan has also performed several Radio Science Occultation, Bi-static and Quasi-specular Radar experiments.

Magellan's accomplishments include: mapping over 98% of the planet surface, obtaining high resolution gravity data over 95% of the surface, successfully accomplishing aerobraking to change the orbit, and performing several other experiments (Radio Science Occultation, Bi-static, Quasi-specular and Windmill).

OPERATIONS PROCESS - Prior to launch, the mission operations procedures and plans for the Spacecraft Team (SCT) were developed on the premise that the orbit would be repetitive and day-to-day tasks would thus be simple and low cost. The majority of the tasks (approximately 70%) would involve analyzing and trending the engineering data received from the spacecraft, while the remaining time would be for the command process. The data analysis and trending workload estimate was based on previous planetary spacecraft operations that relied on simple displays and manually analyzing engineering data. For Magellan, the spacecraft data analysis and trending would be performed using the new JPL multi-mission operations process and multi-tasking workstations, but trending was still perceived as a manual process.

The command process was developed using sequences based on repetitive mapping orbital operations, intending to minimize the effort required for commanding. The mission planning and sequence development processes relied on meetings, paper products and manual reviews similar to previous spacecraft's. Rather than the simple process envisioned, the command process resulted in complex operations that were continuously tweaked to improve the science data quality.

The mission progressed as planned and all flight sequence milestones were met. However, the allocation of the work force to accomplish the tasks was radically different. Immediately after

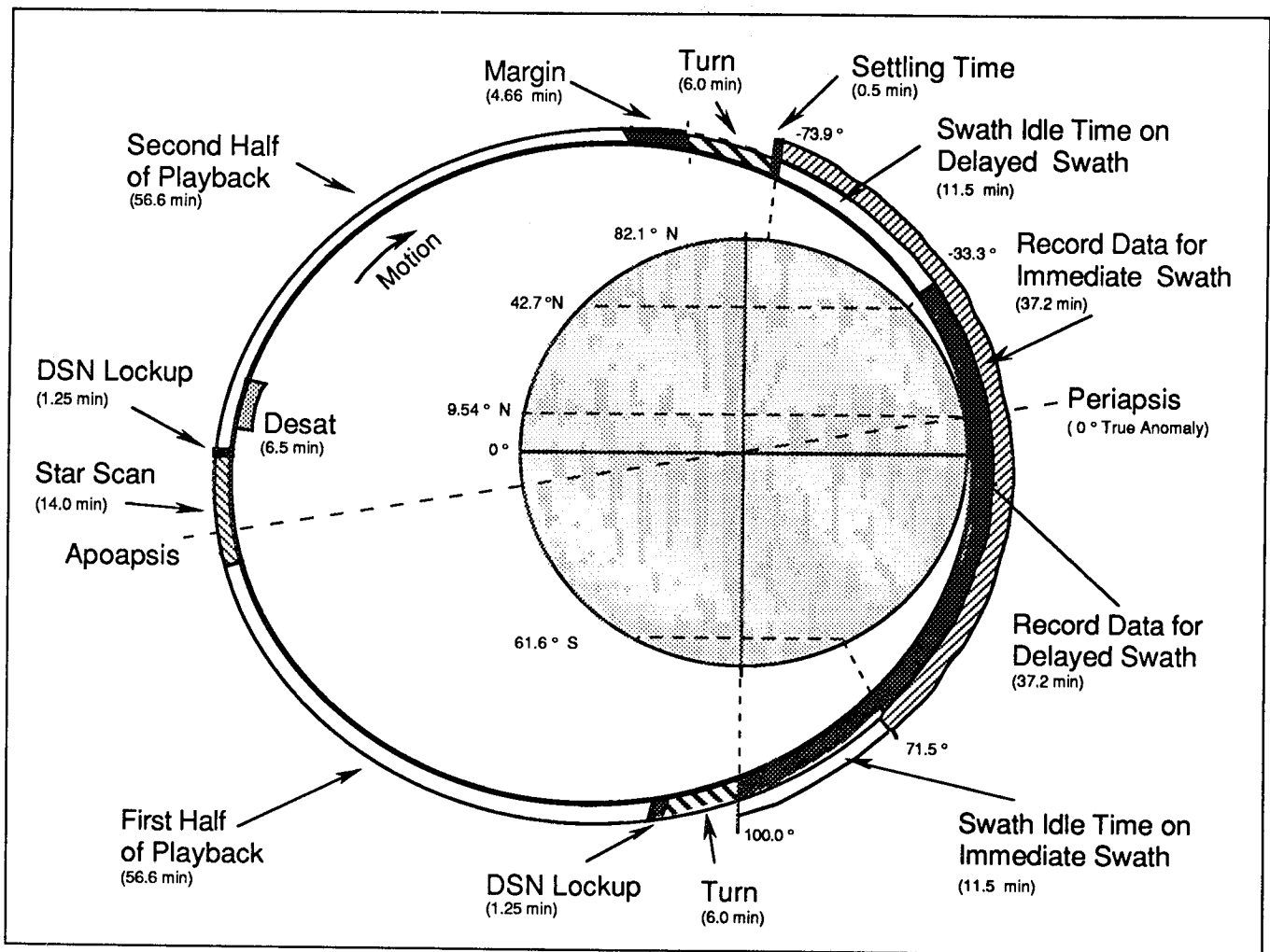

Figure 1 Typical Mapping Activities

launch, anomalies occurred on the spacecraft which required the subsystems engineers to spend an unexpected larger portion of their time performing sequence preparation and validation. The difficulty of operating and maintaining the health of the spacecraft early on (thermal control and star scan problems) combined with a labor intensive command process resulted in a very high percentage of the work effort being placed on commanding. This percentage decreased as the mission operations matured, but the final workload split was approximately seventy percent involving commanding and the remainder for data analysis and trending.

The SCT, faced with a labor intensive command process, a strong desire to obtain higher quantity and quality science data, and budget constraints realized the need to further reduce the time required for the spacecraft data analysis and trending. Using the framework of

the multi-mission operations tools and the processing capability of the workstations, the SCT developed batch scripts and other software routines that allowed the spacecraft data to be collected, analyzed, and displayed automatically. The data analysis and trending were performed during off hours and the results were available for the engineers to examine when they arrived in the morning. If the results were nominal, the engineers could then devote their time to the command process. If an anomaly was present, their time was used to determine the cause and corrective action, which generally involved more commanding.

The automation of the data analysis and trending was achieved because the tools allowed these tedious tasks to be performed by computers. In addition, the SCT was comprised of engineers with the necessary computer skills to automate tasks and encouraged by program management to

perform continuous process improvement. The automation process was further enhanced by the SCT conviction that the mission operations budget must be reduced if an extended mission was to be affordable. The planning for the successful Aerobraking operations accomplished during Cycle 4 was made possible by the mission operations savings during the earlier cycles. These savings were the direct results of the automation and improvement process.

MAGELLAN COMMAND PROCESS -

The Mission Operations Plan was for spacecraft sequences to be developed using a standard process (initially a twelve week duration) which relied on stored commands to perform the tasks necessary to obtain science data. In addition to mapping commands, health and maintenance commands were also to be included with the standard (stored) sequence. The standard command process utilized repetitive commands each orbit with minor periodic parameter updates to minimize operations costs.

However, this simplicity was not realized due to the program's desire to maximize the quality of the science data. To improve the science data, the frequency of parameter updates had to be increased. Additional complexity arose because of the need to manage thermal control and star scan issues. Prior to Venus Orbit Insertion, the SCT realized that the plan to send a new mapping sequence every week would be difficult to achieve at the current staffing level despite the time savings from automation of the data analysis and trending. The creativeness of the engineers was allowed to manifest itself, resulting in an extended sequence (two weeks) and manageable parameter updates the staff could accommodate while still obtaining the highest quality science data.

As spacecraft anomalies developed and operating idiosyncrasies became apparent, non-stored (called non-standard) commands were required to meet maintenance issues, investigate anomalies and conduct characterization tests. These non-standard commands were developed using the standard command process but could not be placed in the stored sequence due to their near real time nature.

Standard Command Process - As shown in the orbit profile (Figure 1), the mapping data collection and playback required the spacecraft to perform six maneuvers each orbit. In addition to developing the commands to maneuver the spacecraft, commands (Figure 2) were required to

control the radar mapping parameters, manage the tape recorders, perform desaturations of the reaction wheels, and manage the telecommunications system. A typical orbit had over a hundred separate commands to perform.

In addition, the SCT had over a thousand variables in flight software to track and maintain. In order to perform the mapping mission, mapping and flight software parameters were stored on-board. Mapping parameters included the orbit's periapsis time, radar parameters tailored for the upcoming terrain and a mapping quaternion polynomial coefficient file required to constantly change the mapping attitude. Flight software parameters were the star scan parameters and gyro bias and scale factors. Also updated each sequence load were safing parameters for possible use by the fault protection system. This complexity was underestimated prior to launch and combined with non-standard commanding contributed to the increase in effort required for the standard process.

The original plan, once on orbit, called for a new sequence of commands to be uplinked to the spacecraft every week. Before Venus Orbit Insertion (VOI), the plan was changed to uplinking a sequence every two weeks because it was realized the program could not support the workload involved to develop and review a sequence each week. Each standard two week sequence took approximately 12 weeks to develop which meant that the SCT was working on up to six sequences at a time. This workload was labor intensive due to the amount of time required to: generate parameters; develop and review three cycles (preliminary, intermediate and final) of Sequence Events Files (SEF); review other uplink products; and perform a test in the System Verification Laboratory. The standard sequence cycle was marked by meetings, reviews, and reams of paper. The amount of time spent in meetings was also underestimated. Meeting time included presentation preparation, future sequence planning, reviewing developed sequences, and presenting subsystem performance. In Cycle 1, it was estimated that a typical subsystem engineer could spend twenty to twenty-five hours per week in meetings. Adding to the complexity was tracking six sequences at once, ensuring the right parameters were developed and coordinating activities between sequences.

After the successful completion of Cycle 1, the number of people on the SCT slowly

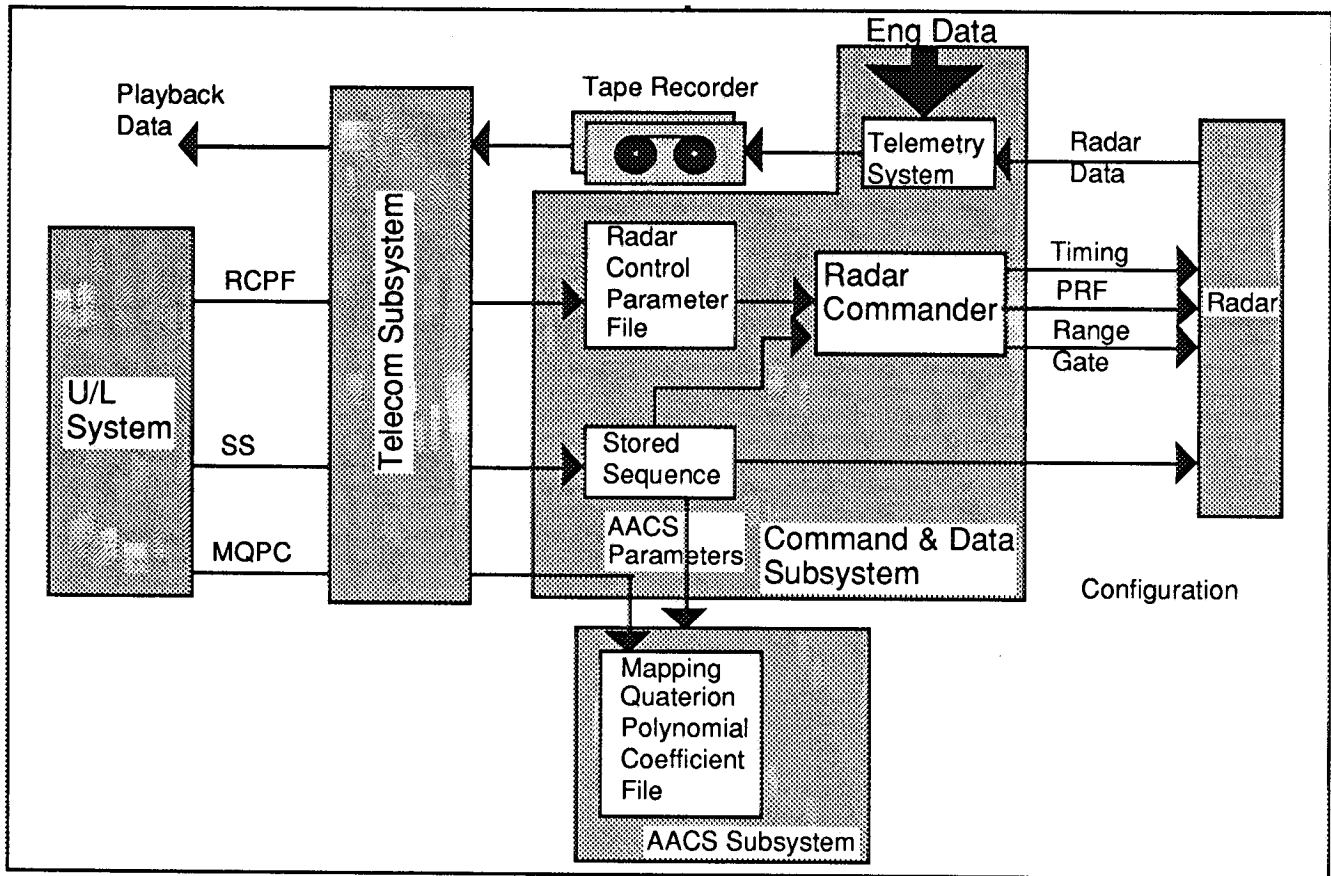

Figure 2 Typical Mapping Commands and Flow

decreased as personnel left the program. It was apparent that the existing standard process could not be supported with the smaller staff. A revised standard process was developed which eliminated the intermediate SEF products and took advantage of further automation to reduce time for command development, generation, and reviews. The new process took six weeks to produce the uplink commands thus reducing the number of sequences in work to three. The new process also reduced the amount of time required to prepare products by eliminating non-value added traditions such as management approval of technical parameters. To help achieve the reduced schedule, standard spacecraft maneuver times were developed which would reduce the analysis required for each sequence. The standardized maneuvers were never fully realized since spacecraft anomalies required each sequence to be as unique as in the first cycle. The new standard sequence process reduced the number of meetings, automated reviews and consumed less paper since electronic versions of uplink products were used. This six week process continued

through the third mapping cycle when mapping operations were halted due to failed transmitters.

The fourth cycle was a gravity only cycle and saw a reduction in the amount of work required because the mapping associated parameter development and reviews were not necessary. The program moved to three week sequences which meant only two sequences were in work at any one time since the standard process duration remained at six weeks. This allowed a smaller work force (thirty people) to continue to develop standard sequences and non-standard commands and prepare for aerobraking operations at the completion of the fourth cycle.

The program was presented with an opportunity to obtain high resolution global gravity data by nearly circularizing the orbit through aerobraking. Aerobraking the spacecraft was a high risk endeavor since it had never been attempted before with a planetary spacecraft. In addition, aerobraking was to be performed with a spacecraft that was not designed for it. The program engineers had to develop the aerobraking profile (attitude and duration) and commands for

performing aerobraking. The existing mapping block did not meet the requirements, therefore a new aerobraking block had to be developed and tested. This full time effort consumed approximately half of the SCT which meant the remaining half performed the nominal tasks to obtain the important gravity data. Aerobraking operations were developed to ensure that the necessary timing updates (to account for the shrinking orbit) were sent to the spacecraft in a timely manner. At the start of aerobraking, timing commands were sent to the spacecraft three times per week. As the orbit period shrunk, the timing commands were sent every day. At the end of aerobraking, timing commands were sent up to three times per day. Aerobraking was accomplished in seventy days, ten days ahead of schedule.

Following aerobraking, process improvements continued with a change in the way sequences were implemented to take advantage of the near circular orbit. The length of the sequences was increased to three weeks which meant the SCT was working on one sequence at a time. It was these types of improvements that allowed the SCT to collect high resolution gravity data and perform special experiments (Radio Science Occultation, Bi-static, Quasi-specular and Windmill) with a significantly smaller staff.

Non-Standard Command Process - Initially there was no set process to send a non-standard command to the spacecraft. Each subsystem would determine the need, develop the commands, and then present the results to the Mission Director for approval. This resulted in significant re-work as an alternative solution would surface during the presentation to the Mission Director. The alternative solutions led to confusion which resulted in a high number of command related incidents. The non-standard workload was a significant portion of the commanding process because solutions to problems were often re-worked several times.

Several months prior to Venus Orbit Insertion, the Proposed Engineering Change (PEC) process was developed. The PEC process brought discipline to the non-standard commanding effort and reduced the number of command incidents to near zero. The PEC process is started when a subsystem engineer completes a PEC form which describes the reason for the proposed change, the impacts if not implemented, the need date, and alternative

solutions. The PEC is then reviewed by the members of the SCT, updated and then presented to the Mission Director at the Engineering Review Board (ERB) for approval. If approved, the SCT is then authorized to implement the proposed solution and send the non-standard command(s) to the spacecraft. By holding a peer review, impacts to other subsystems are identified as well as better solutions not considered by the originator. This process forced a disciplined thought process which proved invaluable during anomaly recoveries. Over 270 PECs have been written. Of these, only sixteen have been disapproved; the majority were early in the mission as a result of conflicting requests. The small number of disapproval's indicates the PECs brought forth viable solutions in which all members of the SCT and program management concurred. Management developed confidence in the SCT and the solutions to anomalies due to the discipline created by the PEC process.

An example of process improvement is the Express Command. Express Commands are commands that have minimal impact to the spacecraft and were being presented as a PEC on a regular basis. Examples of express commands are memory read out, star scan parameter changes, and turning transmitter sub-carriers on or off. Express Command eliminated the repetitive workload of regularly presenting PECs to the ERB. One PEC was created that defined who could send a command, the conditions in which the command could be sent and the follow up action. Prior to Express Command every command had to be approved by the Mission Director. Now these commands required only approval by the appropriate subsystem, thus empowering the engineers.

REMOTE OPERATIONS - Magellan was the first JPL spacecraft to be flown from a remote location. This posed the problem of how to effectively communicate without face-to-face contact with the other person. The remote arrangement also required that JPL management give up much of its "routine control" over the SCT. By remotely locating the SCT, engineers with more Magellan spacecraft experience were enticed to support mission operations. All subsystem had team members who had been part of all phases of the program. If these engineers had been required to relocate to JPL, many of these experienced individuals would not have been part of the SCT.

The voice communication problem between the remotely located project teams was difficult to solve. Initially the teleconferencing capability was minimal (one speaker phone in a small conference room). Prior to VOI, a large conference room with multiple microphones was made available which improved the technical portion of the voice communication problem. Although both the Denver and the JPL sides worked very hard to effectively communicate, problems still existed. One of the main difficulties was understanding the other side's everyday workload problems. To maximize this understanding, representatives from both sides would travel to the other's facilities on a regular basis. These representatives were usually the Leads of various subsystems/teams. By spending one week every three months at the other person's location these leads developed an appreciation for each other's constraints and abilities. This rotating representative eliminated the belief that the other side "had it easier".

STAFFING - The success of the Magellan Venus Radar Mapping mission has been largely the result of the outstanding performance of the flight system, however, some credit must be given to the mission operations team and the staffing plan. The staffing plan included the

selection of the right people, the organizational structure at the beginning of the program, and systematic downsizing as the program matured. Much of the extended mission operations, including aerobraking, would not have been possible without significant reduction in the size of the SCT. The original plan provided for thirteen engineers monitoring the health of the spacecraft. As the program developed, it became apparent that the simple flight system developed as a low cost solution for the original VOIR program would involve a very complex mission operation if the Magellan science return was to be realized. In addition, the flight software and the fault protection system proved to be extremely complex and their verification and characterization continued during the Cruise Phase to ensure its readiness to support VOI and Mapping Operations.

At launch the SCT had sixty people organized as shown in Figure 3. This number grew to seventy as VOI approached. As mapping operation settled into a routine, the staff level was reduced to fifty by the end of the Cycle 1 and remained steady until the end of Cycle 2. At the end of Cycle 2, spacecraft telecommunication transmitter A's failure caused a major re-planning effort. The resulting potential funding cutoff

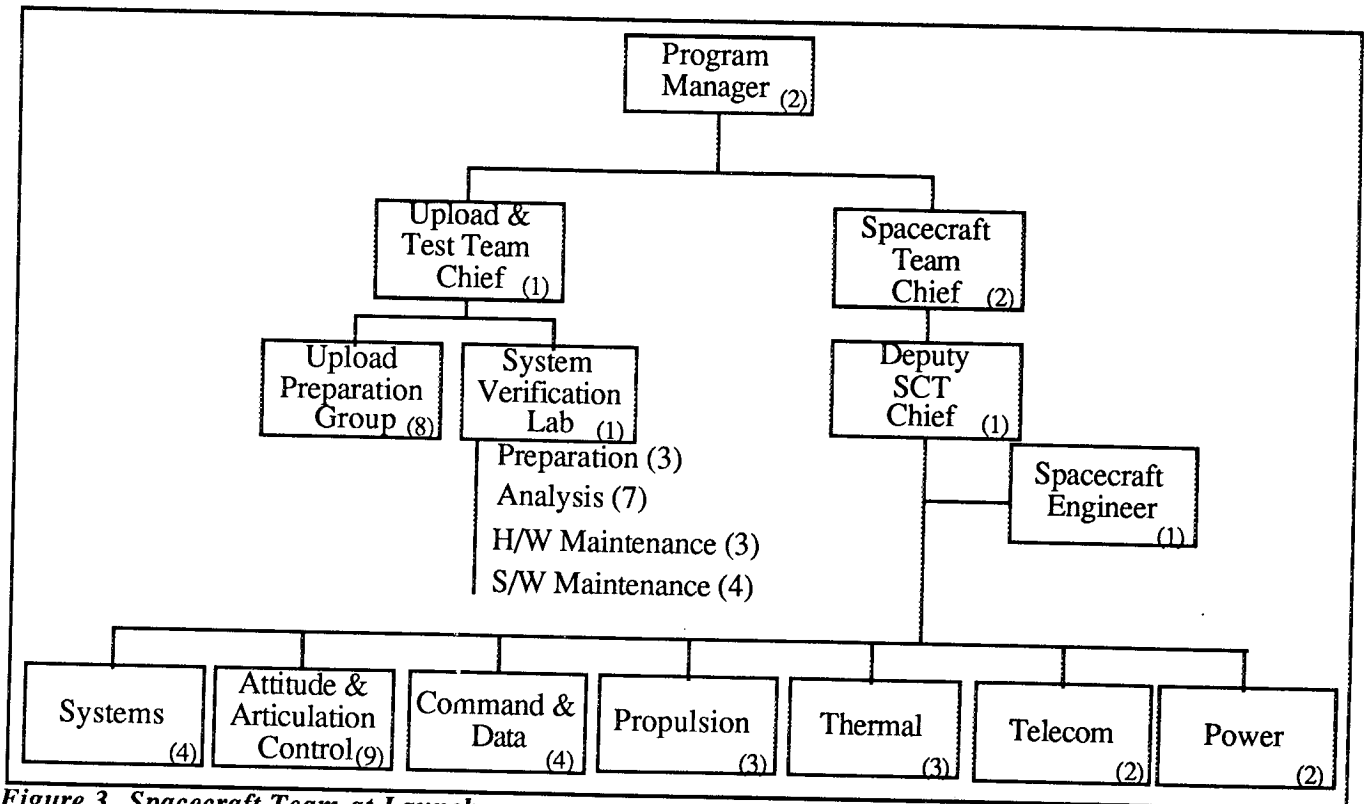

Figure 3 Spacecraft Team at Launch

encouraged the program to look for cost reductions to keep the mission alive. The process of staff reduction while maintaining team morale and productivity and continuing the science mission was a major challenge. This challenge was accepted by the team because of a fundamental belief that a continuation of the mapping mission would yield outstanding science results, but would only be possible if the size of the team and the resulting cost could be significantly reduced. The team size reduction was a product of recommendations and brainstorming sessions by the whole team. Any reduction in staffing was, therefore embraced by the team regardless of its impact on an individual.

The staff reduction effort continued until thirty people remained at the start of Cycle 4. The staffing leveled out at thirty people as the team continued mission operations and planned and conducted aerobraking. After the successful completion of aerobraking, the staff was reduced to fifteen people. At the end of the mission, the SCT was comprised of nine people some of whom were part time.

The staff reduction was accomplished in a positive manner since career growth opportunities on other contracts were available to nearly all of the team members with special skills gained from the Magellan experience. As these engineers left the program, the organization was restructured and/or the roles and responsibilities were distributed among the remaining team members. This process of "belt tightening" gave more responsibility and growth opportunities to the remaining staffing and had a positive impact on the overall team morale despite the ongoing staff reduction. The loss of senior staff did not significantly impact operations because remaining engineers were ready to assume their responsibilities. The automation process that was occurring simultaneously with the staff reduction enabled the available resources to return the maximum science data possible.

Management played an important role by identifying and keeping those individuals who could perform multiple tasks and/or encouraging individuals to become proficient in multiple tasks. This identification process was achieved by providing opportunities for engineers to excel. Throughout the program, management was not satisfied with the status quo. Instead, management encouraged the Leads to do more with less, so when funding faced reduction the

SCT was able to respond quickly with proposed staff reductions.

CONCLUSIONS - Software automation, process improvement, the management environment and a cooperative flight system are the main reasons Magellan has enjoyed such great success. The management philosophy created an environment of continuous process improvement that allowed the SCT to perform a wide variety of tasks with a steadily decreasing staff.

The areas that realized time saving due to automation were sequence preparation, sequence validation, and data analysis and trending. Sequence preparation saw significant savings through the electronic transfer of parameters and automating command generation procedures.

Sequence validation automation was achieved by the creation of software tools designed to replace the manual checks of the command products. Each subsystem had its own checklist that contained the steps necessary to manually validate the command products. As the engineers gained confidence in the checklists, software tools were written to perform the manual checks. This reduced the time to review a typical sequence from eight hours to two hours.

Data analysis and trending were also automated through the use of software and workstation tools. The primary source of automation was the generation of programs and scripts to carry out repetitive tasks that the engineers were required to perform each day. Many of these tasks were not completely characterized prior to launch, so the creation of software tools during spacecraft development was limited. After launch, when the spacecraft performance and ground data systems capabilities were better understood, each subsystem engineer produced a tool set that allowed them to perform their jobs more efficiently. It is important to note that the software coding and script writing was performed by the subsystem engineers and not a software development staff. This created the scenario where the end user was also the programmer, so the tools developed meet the needs without significant interaction.

ACKNOWLEDGMENTS - This work was performed by Martin Marietta Astronautics in Denver, Colorado while under contract to the NASA Jet Propulsion Laboratory for Magellan spacecraft operations.