

NLS Base Heating CFD Analysis

Edward, P. Ascoli, Adel H. Heiba, Yann-Fu Hsu,
Ronald R. Lagnado, and Edward D. Lynch

Rockwell International, Rocketdyne Division

Workshop for Computational Fluid Dynamic
Applications in Rocket Propulsion

April 20-22, 1993
NASA Marshall Space Flight Center

1995-117012

520-34
437-95
P. 35

Abstract

Concerns raised over possible base heating effects on the NLS 1.5 stage reference vehicle resulted in the use of CFD as a predictive analysis tool. The objective established was to obtain good engineering solutions to describe the base region flowfields at 10,000 ft. and 50,000 ft. altitudes. The Rockwell USA CFD code was employed with a zero-equation turbulence model and a four species, 1 step chemical kinetics package. Three solutions were generated for the specified altitudes on coarse and fine grids. CFD results show the base region flowfields to be highly three-dimensional in character. At the 10,000 ft. altitude, plumes contract soon after exiting the nozzles and do not interact with each other. No mechanism was identified for driving hot gas back into the base region and no significant amounts of hydrogen or water were found in the base region. Consequently, surface temperatures were all near the ambient level. At 50,000 ft., the nozzle exhaust plumes begin to interact, particularly those of the two inboard engines which are closer together. A small amount of hot gas is recirculated between the inboard nozzles near the nozzle exit plane. As a result, base region surface temperatures are slightly elevated, but still remain well within the design guideline of 1000°R.

NLS BASE HEATING CFD ANALYSIS

**Edward P. Ascoli
Adel H. Heiba
Yann-Fu Hsu
Ronald R. Lagnado
Edward D. Lynch**

Rockwell International, Rocketdyne Division

**Workshop for Computational Fluid Dynamic
Applications in Rocket Propulsion**

**April 20-22, 1993
NASA Marshall Space Flight Center**



ROCKETDYNE BASE HEATING CFD ANALYSIS TEAM

CFD Technology Center Management

M. Sindir, Manager S. Barson, Project Engineer

Base Heating Analysis (Rocketdyne)

E. Ascoli* E. Lynch
A. Heiba* R. Ungewitter
Y. Hsu M. Williams
R. Lagnado* (L) R. Yang

Data Visualization and Computing (Rocketdyne)

S. Barson
M. DeCroix (L)
D. Fashena

USA Code Consulting (Rockwell Science Center)

S. Chakravarthy

Graphical Animation Consulting (NASA Ames/Sterling Software)

K. McCabe

*Full Time (L) Technical Lead

INTRODUCTION

- **CONCERNS RAISED OVER POSSIBLE BASE HEATING/BURNING EFFECTS ON NLS 1.5 STAGE REFERENCE VEHICLE**
- **UNIQUE CONFIGURATION**
 - SIX ENGINE CLUSTER
 - HYDROGEN FILM COOLANT INTERNAL TO NOZZLE WALL
 - HYDROGEN-RICH TURBINE EXHAUST USED AS COOLANT
 - DUMPED FROM NOZZLE WALL IN EXIT PLANE
- **CONCERN OVER APPLICABILITY OF EXISTING BASE HEATING DATABASE**

CFD IDENTIFIED AS ALTERNATE PREDICTIVE TOOL

APPROACH

- **OBTAIN ENGINEERING SOLUTION FOR THE 1.5 STAGE REFERENCE GEOMETRY AT 10,000 AND 50,000 FT ALTITUDES**
 - 3-D CALCULATIONS USING TWO GRIDS (638K, 212K POINTS)
 - FINE GRID JUDGED ADEQUATE FOR FLOW ENVIRONMENT DEFINITION PURPOSES (BASED ON EXPERIENCE & AXISYMMETRIC RESULTS)
 - 0-EQUATION TURBULENCE MODEL AND COMPLETE COMBUSTION CHEMISTRY MODEL
 - CONVERGENCE MONITORED THROUGH CONVENTIONAL CRITERIA (RESIDUALS) AND CHANGES IN LOCAL VALUES
 - ASSESSMENT OF KEY PARAMETERS CARRIED OUT VIA SINGLE ENGINE AXISYMMETRIC FLOW CALCULATIONS
 - GRID RESOLUTION
 - TURBULENCE MODELS
 - CHEMISTRY MODELS
 - VALIDATION DONE WITH AVAILABLE DATA ON RELEVANT 2-D & 3-D GEOMETRIES
-
- **ALL CALCULATIONS DONE WITH USA CODE**

NLS 1.5 STAGE GEOMETRY

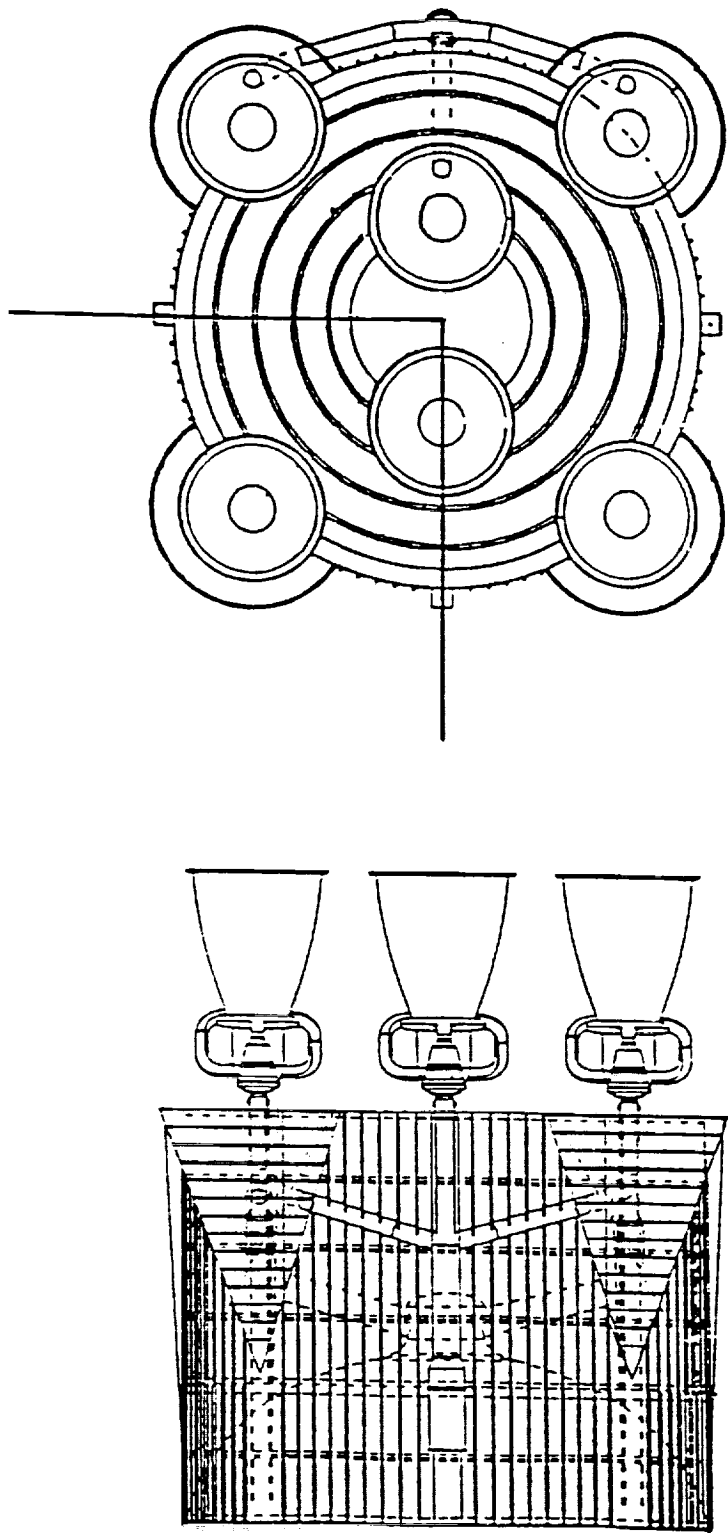

- 1.5 STAGE REFERENCE VEHICLE
- GRID MODELS ONE QUADRANT (TWO SYMMETRY PLANES)
- CYCLE 0 HEAT SHIELD, BASE, FARFIELD, AND DOWNSTREAM REGIONS INCLUDED

CFD MODEL OF NLS 1.5 STAGE VEHICLE BASE AND ENGINE CLUSTER (CONT'D)

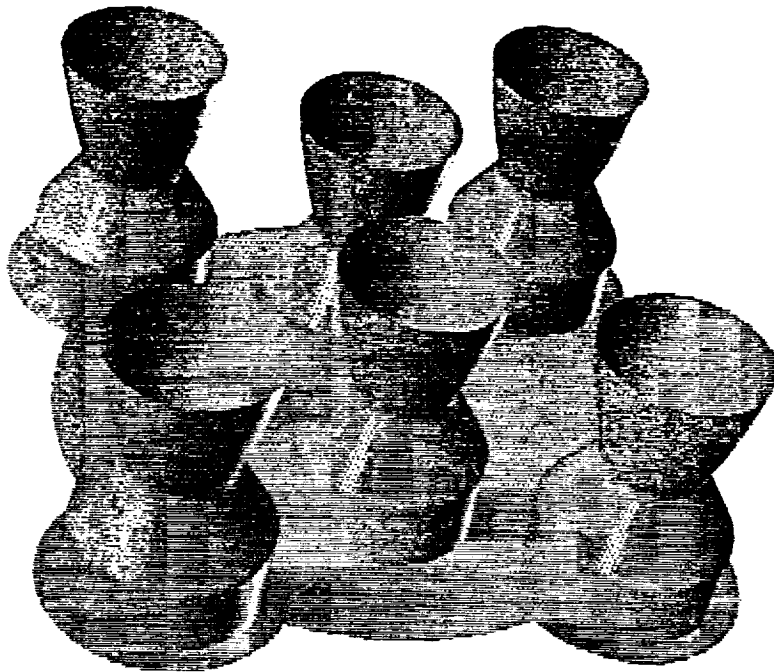
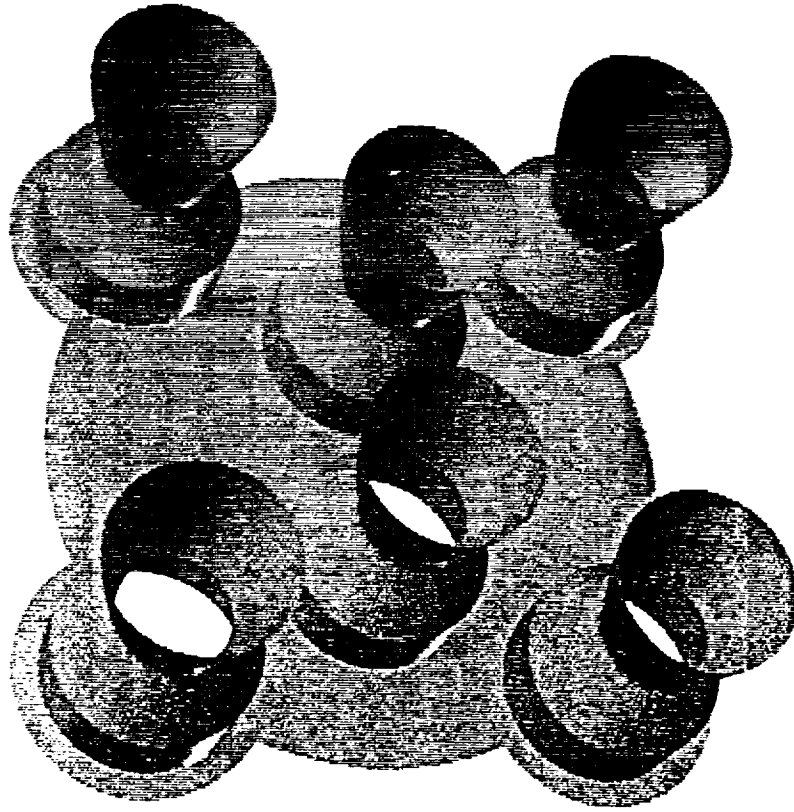

CFD 92-042-061/03/SLB

NLS 1.5 STAGE VEHICLE BASE AND ENGINE CLUSTER MODELED THROUGH SYMMETRY

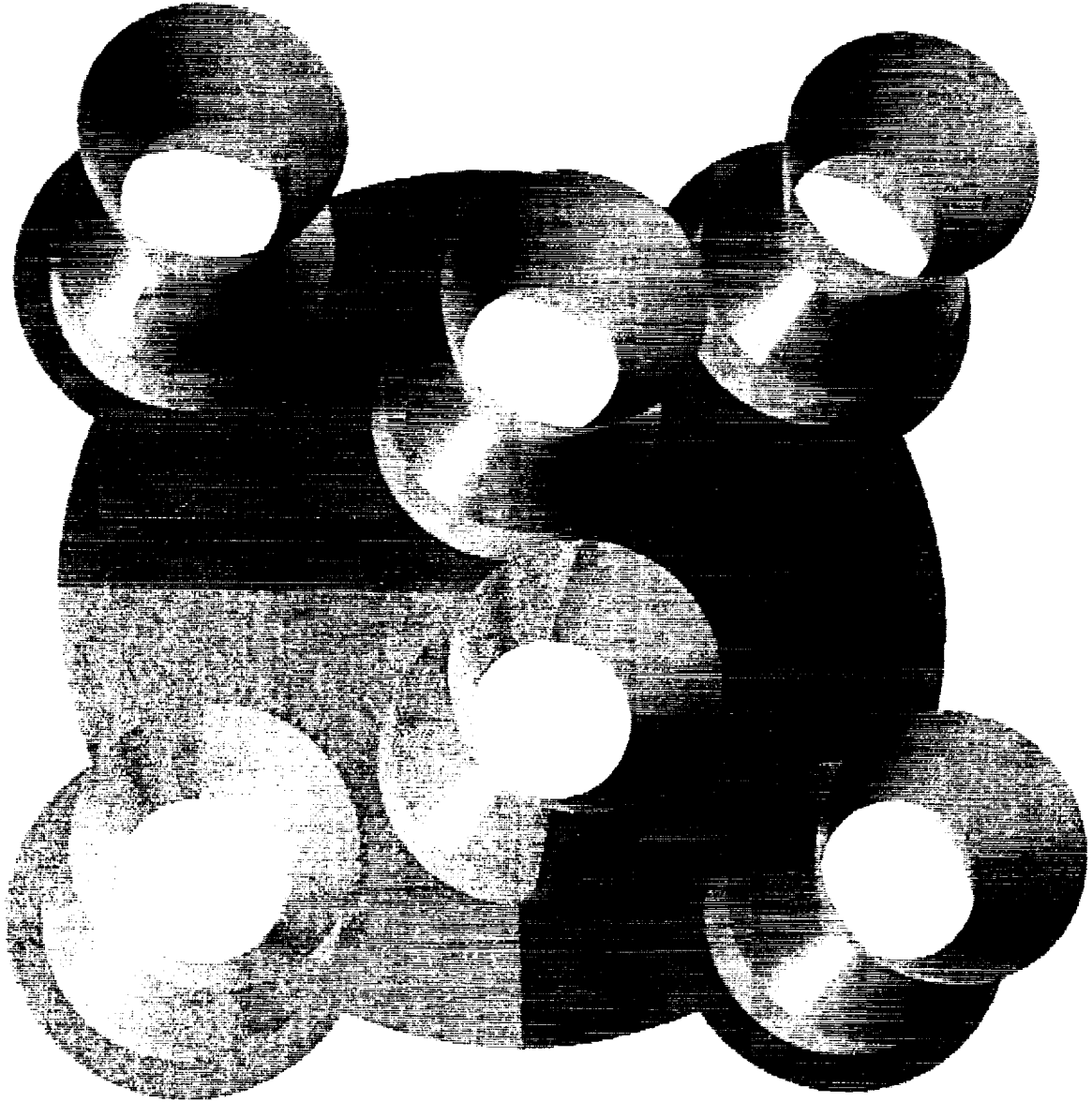

1.5 STAGE REFERENCE VEHICLE GRID STRUCTURE

ZONE	COLOR	I _{MAX}	J _{MAX}	K _{MAX}	NODES = (I _{MAX}) x (J _{MAX}) x (K _{MAX})		X _{MIN}	X _{MAX}	COMMENTS
1	RED	100	30	56	168,000		0	147	J = 1 IS FULL ENGINE SURFACE I = 1 IS BASE OF VEHICLE
2	BLUE	100	12	53	63,600		0	147	J = 1 IS HALF ENGINE SURFACE I = 1 IS BASE OF VEHICLE
3	YELLOW	100	13	10	13,000		0	147	I = 1 IS BASE OF VEHICLE J = 1 COMPLETES FULL ENGINE SURFACE
4	GREEN	80	30	56	134,400		147	550	EXTENDS ZONE 1
5	LAVENDER	80	12	53	50,880		147	550	EXTENDS ZONE 2
6	BLACK	80	13	10	10,400		147	550	EXTENDS ZONE 3
7	LT. BLUE	80	21	65	109,200		147	550	J = 1 IS CENTERLINE OF FULL ENGINE J = 21 IS CYLINDER MATCHING FULL ENGINE OUTFLOW CIRCLE
8	GRAY	80	21	53	89,040		147	550	AS WITH ZONE 7 BUT EXTENDS HALF ENGINE
					TOTAL = 638,520				

1.5 STAGE REFERENCE VEHICLE GRID TOPOLOGY

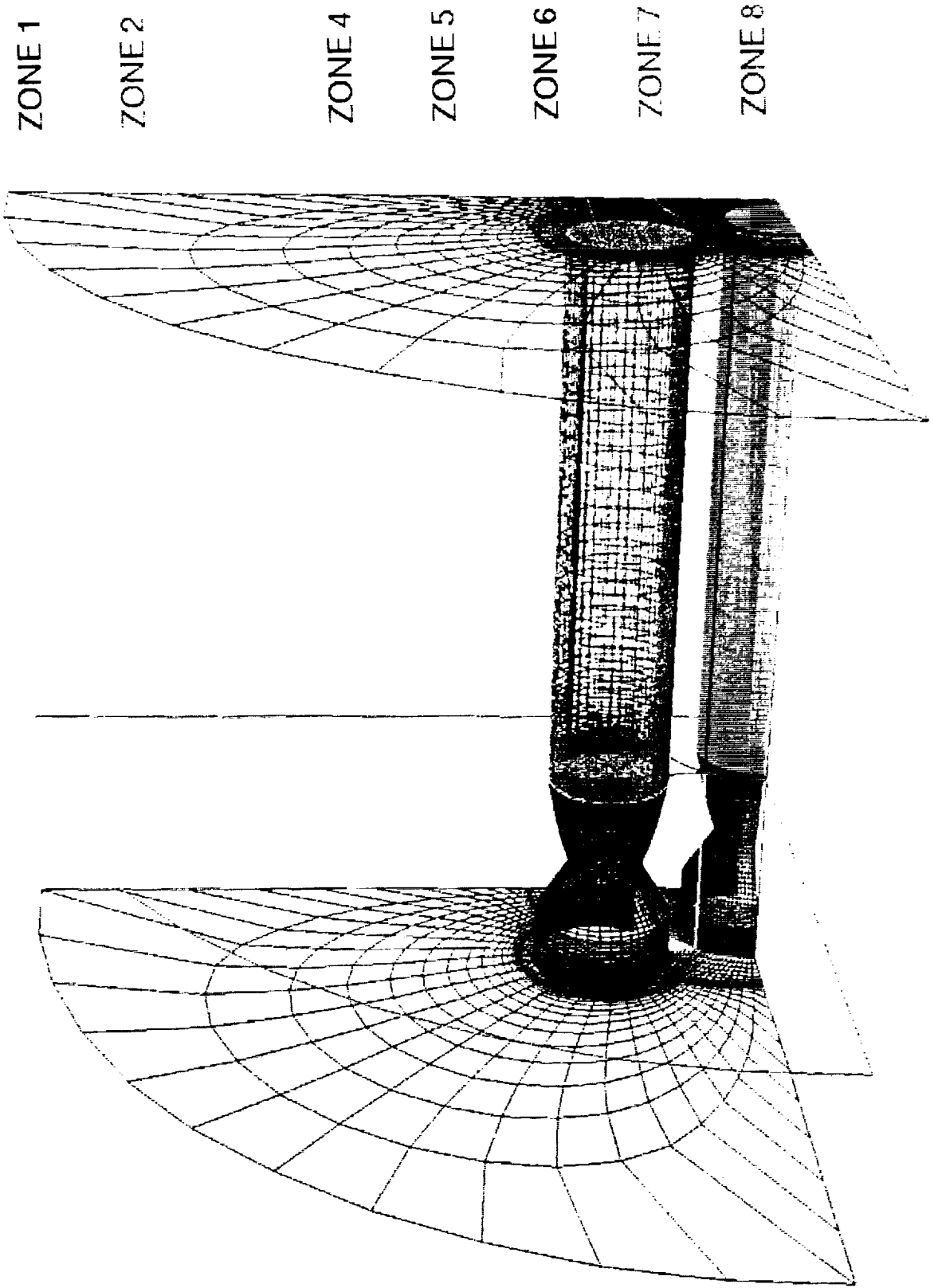

1.5 STAGE REFERENCE VEHICLE GRID TOPOLOGY (CONT'D)

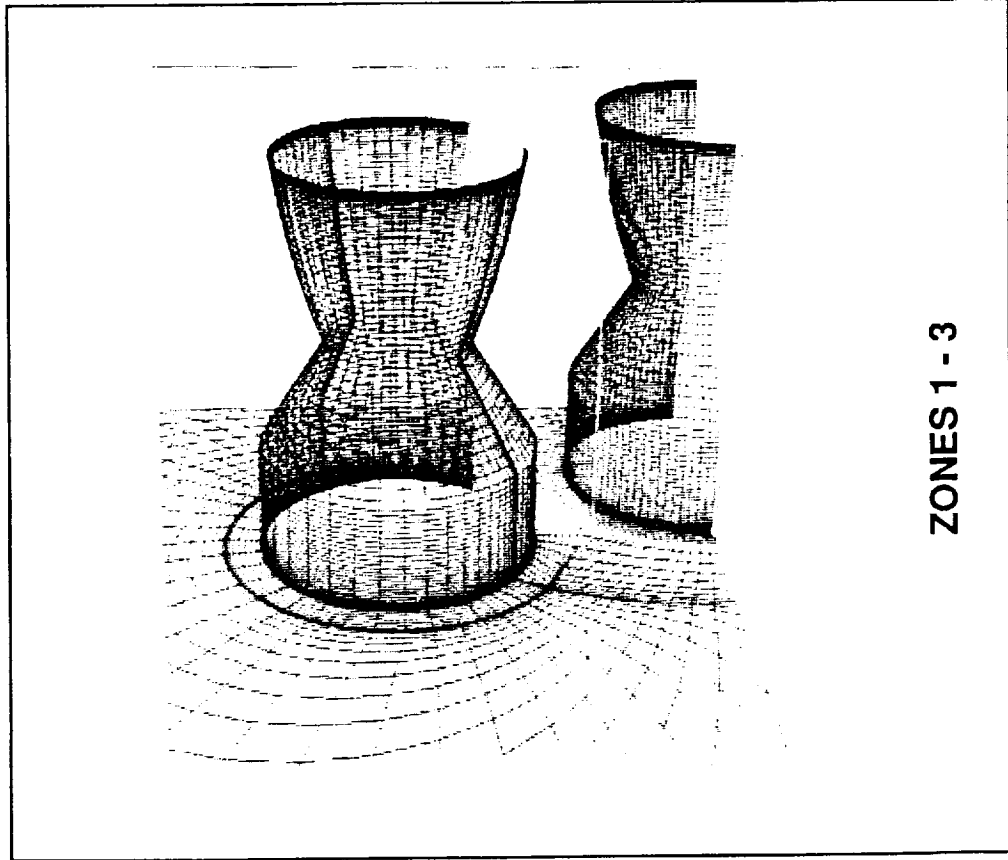

ZONES 1 - 3

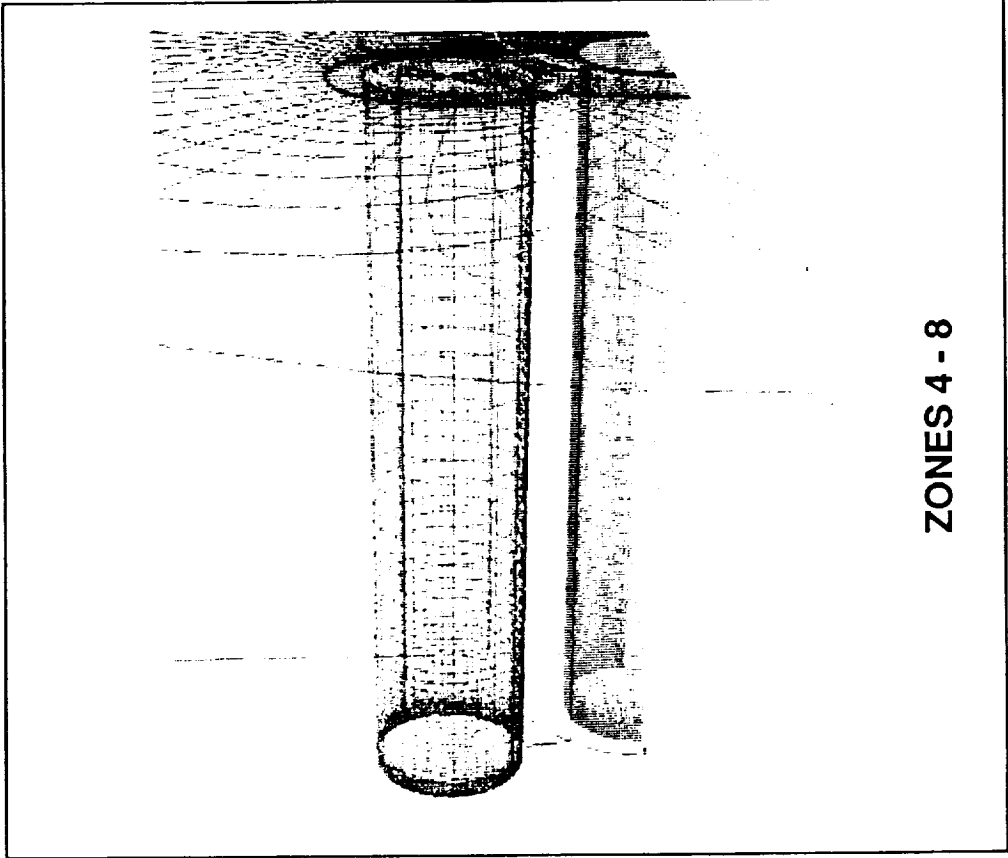

ZONES 4 - 8

BOUNDARY CONDITIONS APPLIED

BOUNDARY CONDITION	COLOR	DESCRIPTION
1	LT. BLUE	SPECIFIED VELOCITY PROFILE (FREESTREAM + B.L. PROFILE)
2	BLUE	NO-SLIP, ADIABATIC WALL
3	RED	CFD COMPUTED NOZZLE EXIT FLOW
4	YELLOW	SYMMETRY
5	GREEN	ZERO GRAIDENT/SPECIFIED BACK PRESSURE
6	TRANSPARENT	FREESTREAM



BOUNDARY CONDITIONS APPLIED (CONT'D)

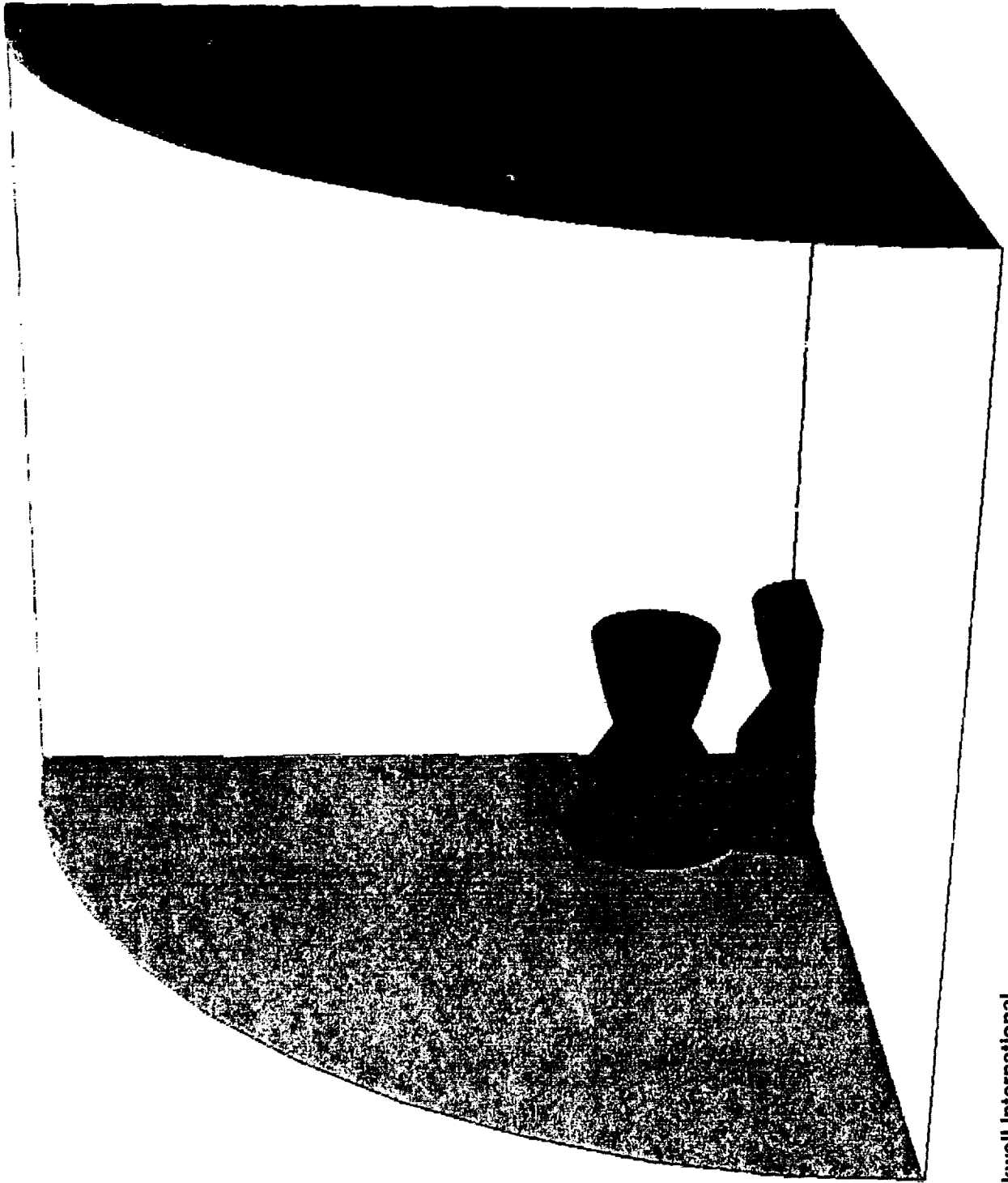

BOUNDARY CONDITIONS APPLIED (CONT'D)

THERMAL BOUNDARY CONDITION OPTIONS

- **ADIABATIC WALL CONDITION**
 - CONSERVATIVE - PROVIDES HIGHEST TEMPERATURES
 - MORE ACCURATE FOR COARSE GRID CALCUALTIONS
 - ASSUMES ZERO HEAT FLUX BY DEFINITION
- **SPECIFIED WALL TEMPERATURE**
 - ISOTHERMAL OR SPECIFIED PROFILE
 - REQUIRES FINE GRID NEAR SURFACE
 - ALLOWS DIRECT HEAT FLUX CALCULATION

PARTICLE TRACES IN BASE REGION

10,000 FOOT ALTITUDE

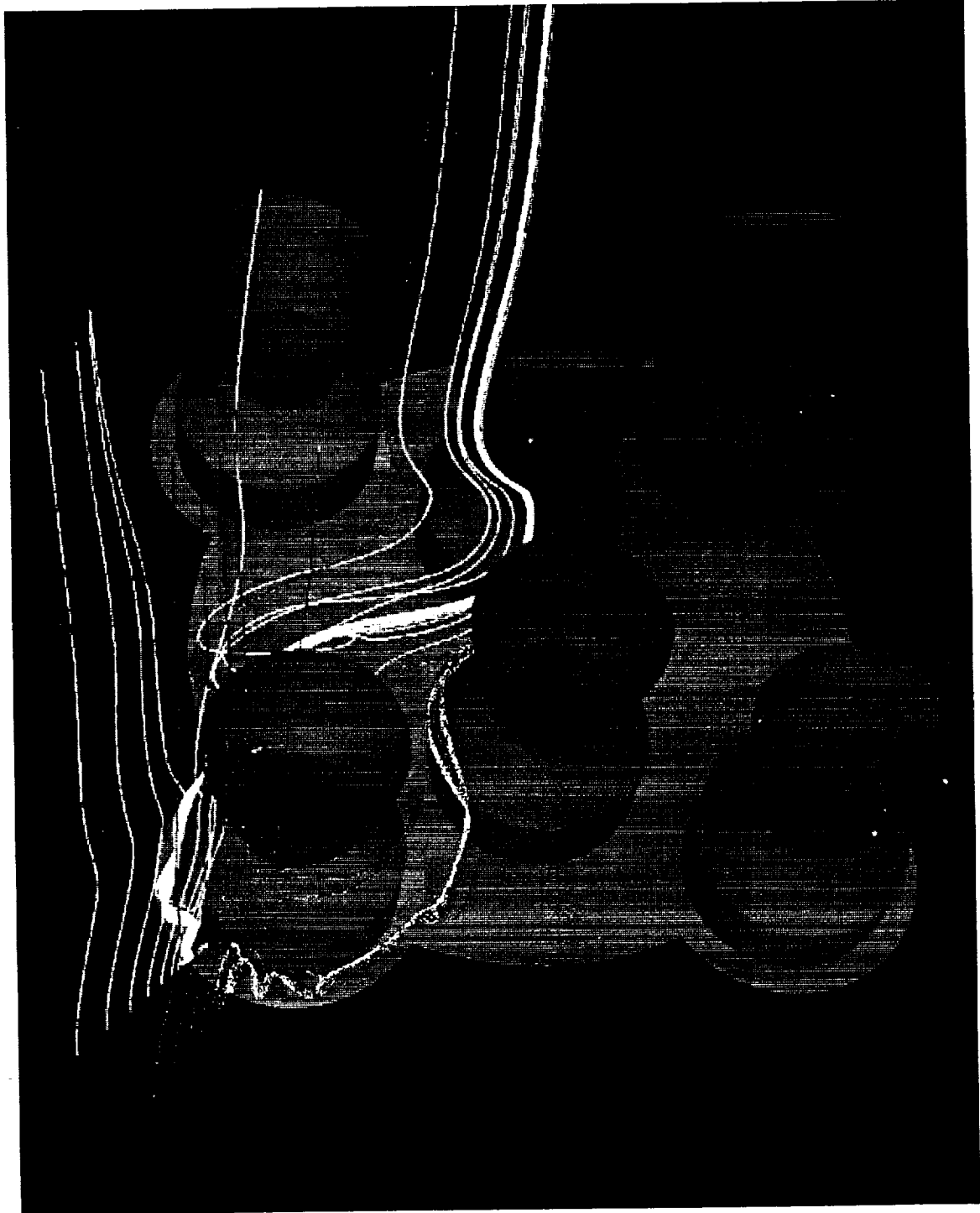

PARTICLE TRACES IN BASE REGION (CONT'D)

10,000 FOOT ALTITUDE



BASE REGION MACH CONTOURS (CONT'D)

10,000 FOOT ALTITUDE

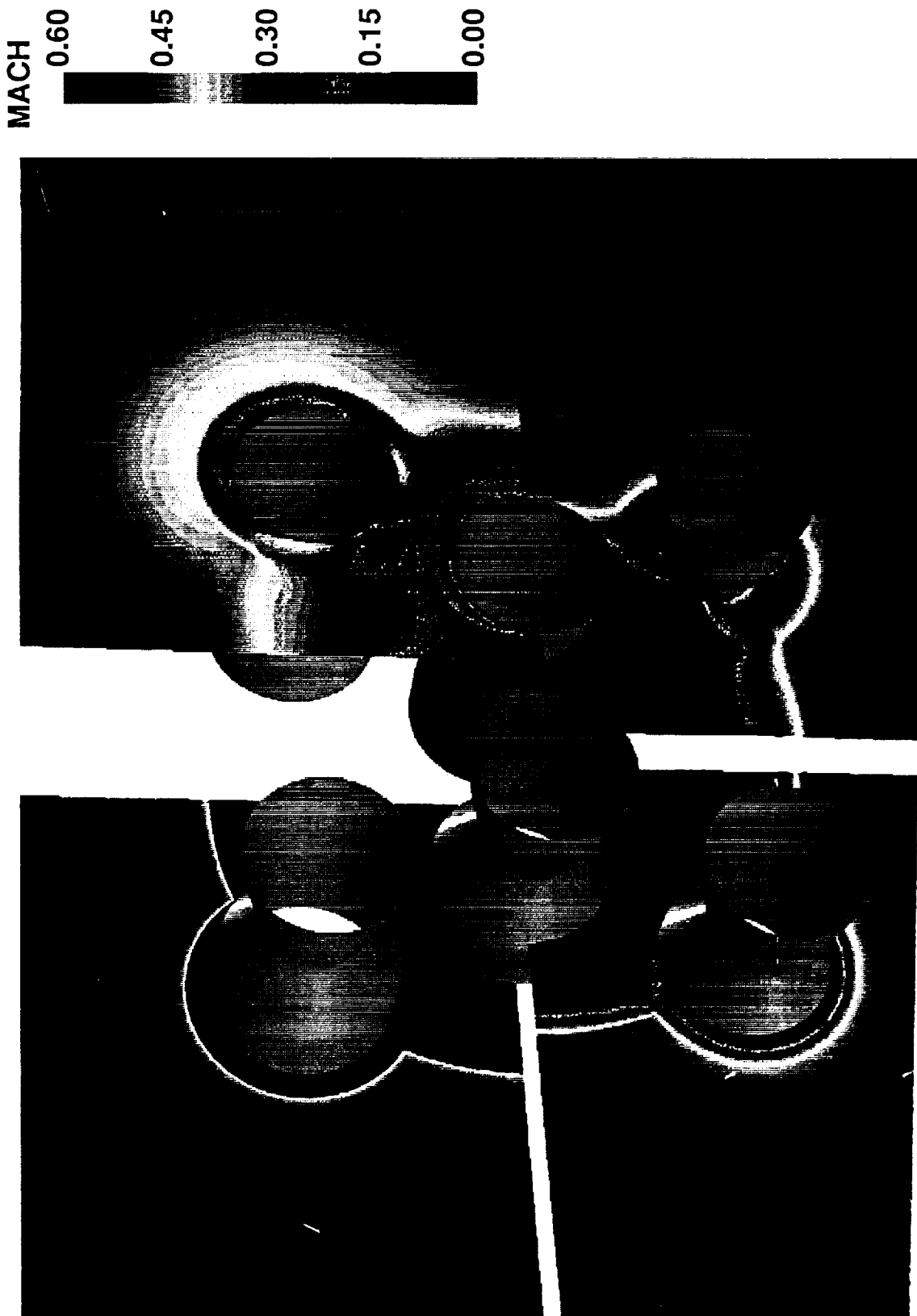

PLUME REGION MACH CONTOURS 10,000 FOOT ALTITUDE

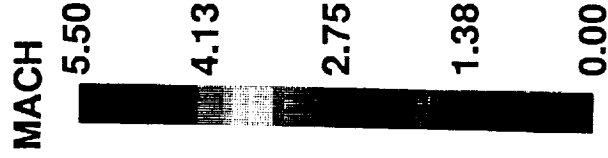

PARTICLE TRACES FROM NOZZLE EDGE

10,000 FOOT ALTITUDE

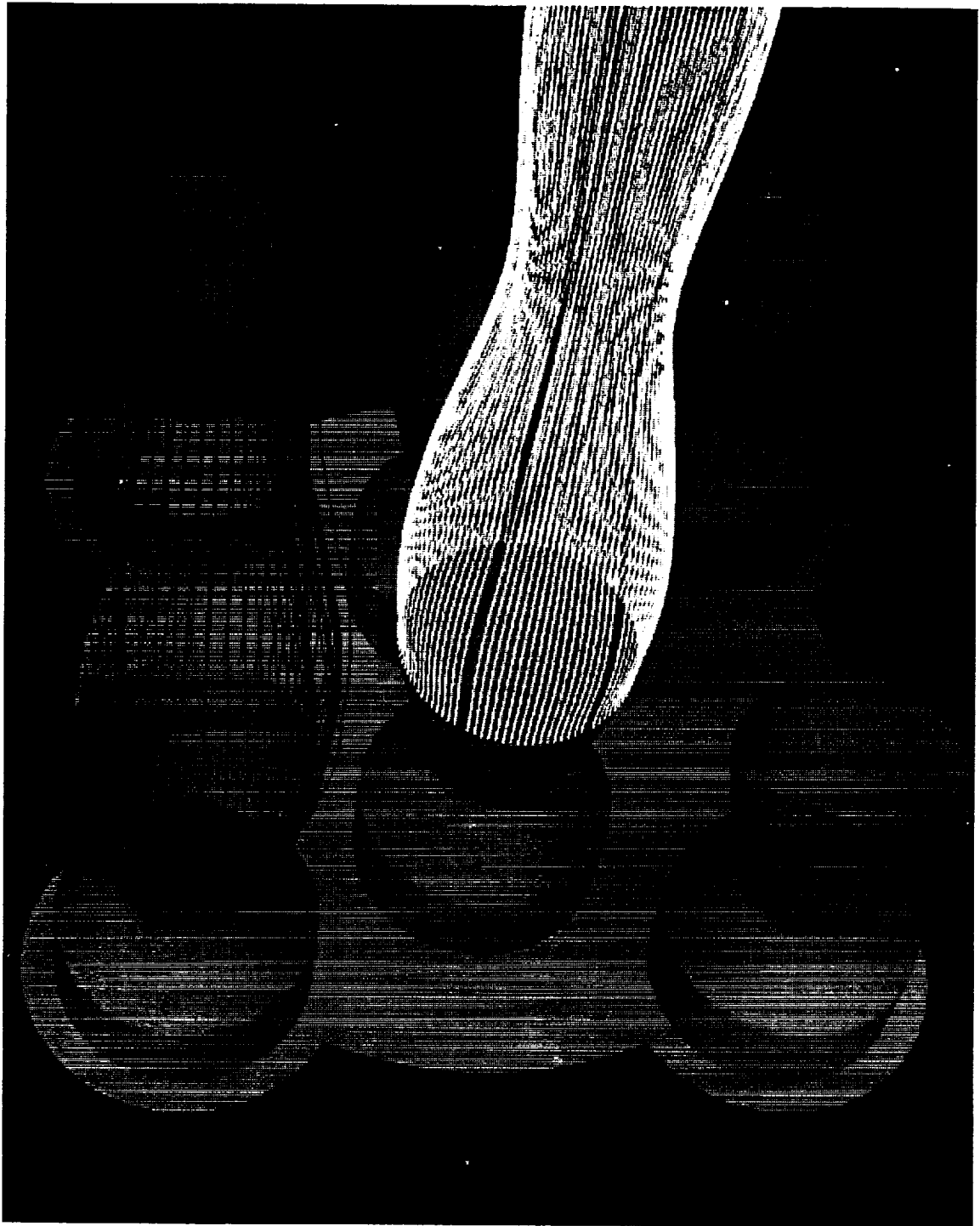

BASE REGION H2 CONTOURS (CONT'D)

10,000 FOOT ALTITUDE

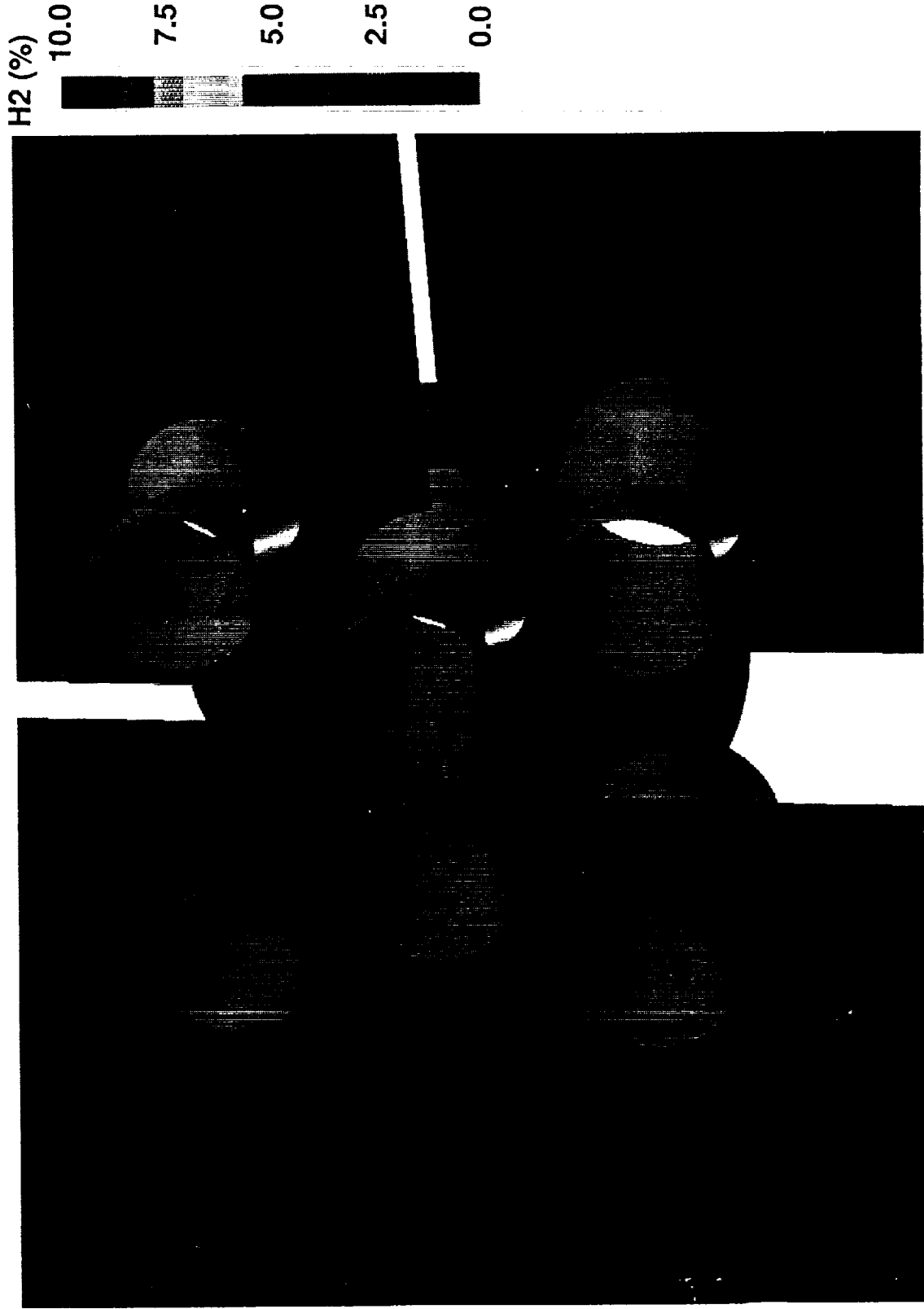

BASE REGION TEMPERATURE CONTOURS (CONT'D)

10,000 FOOT ALTITUDE

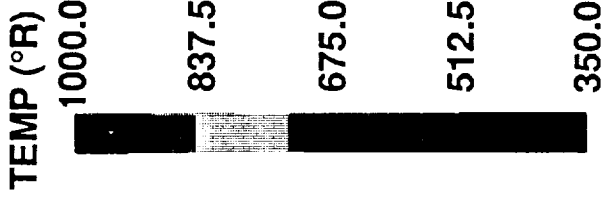
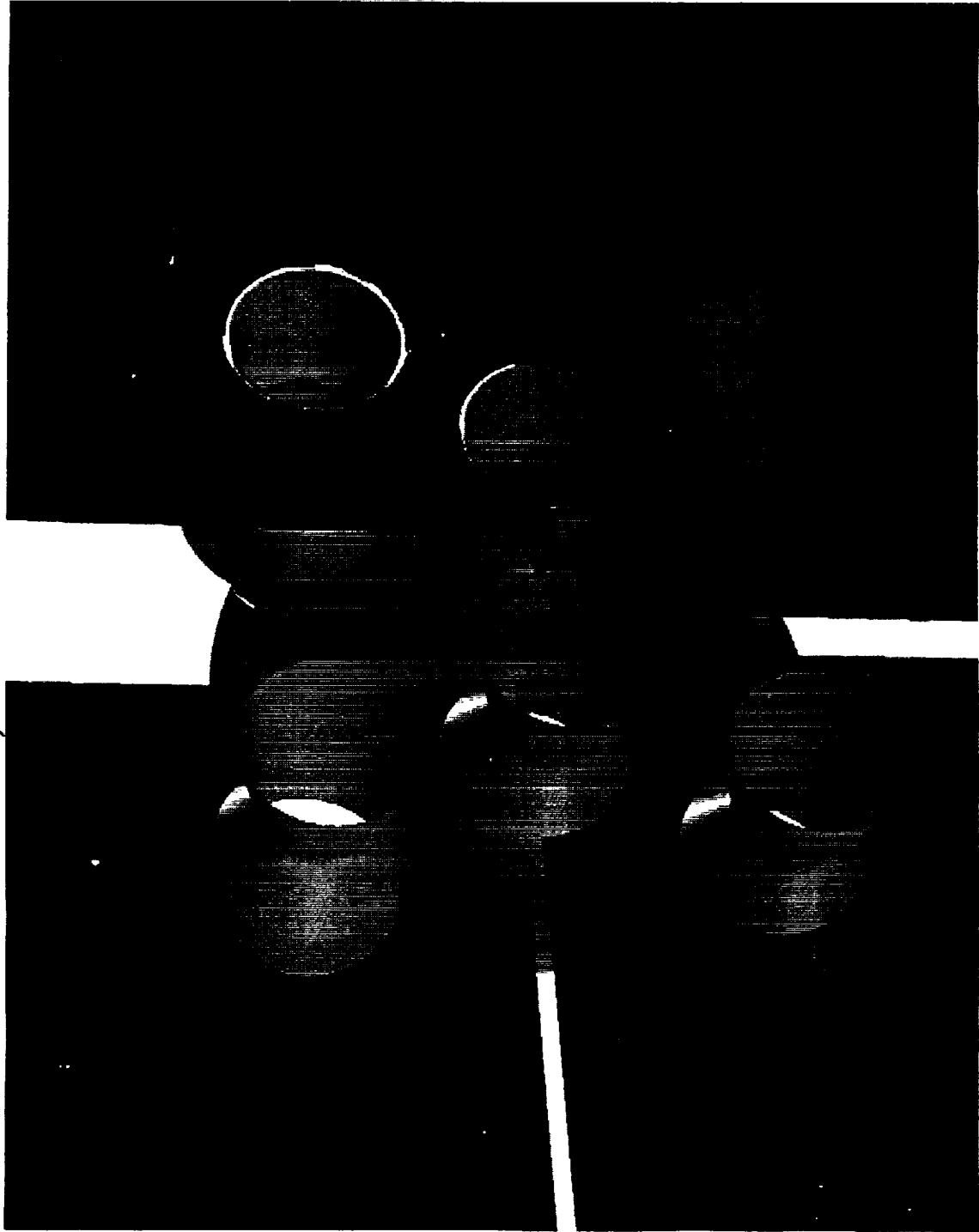

BASE REGION SURFACE TEMPERATURE CONTOURS

10,000 FOOT ALTITUDE

TEMP (°R)

1000.0

837.5

675.0

512.5

350.0

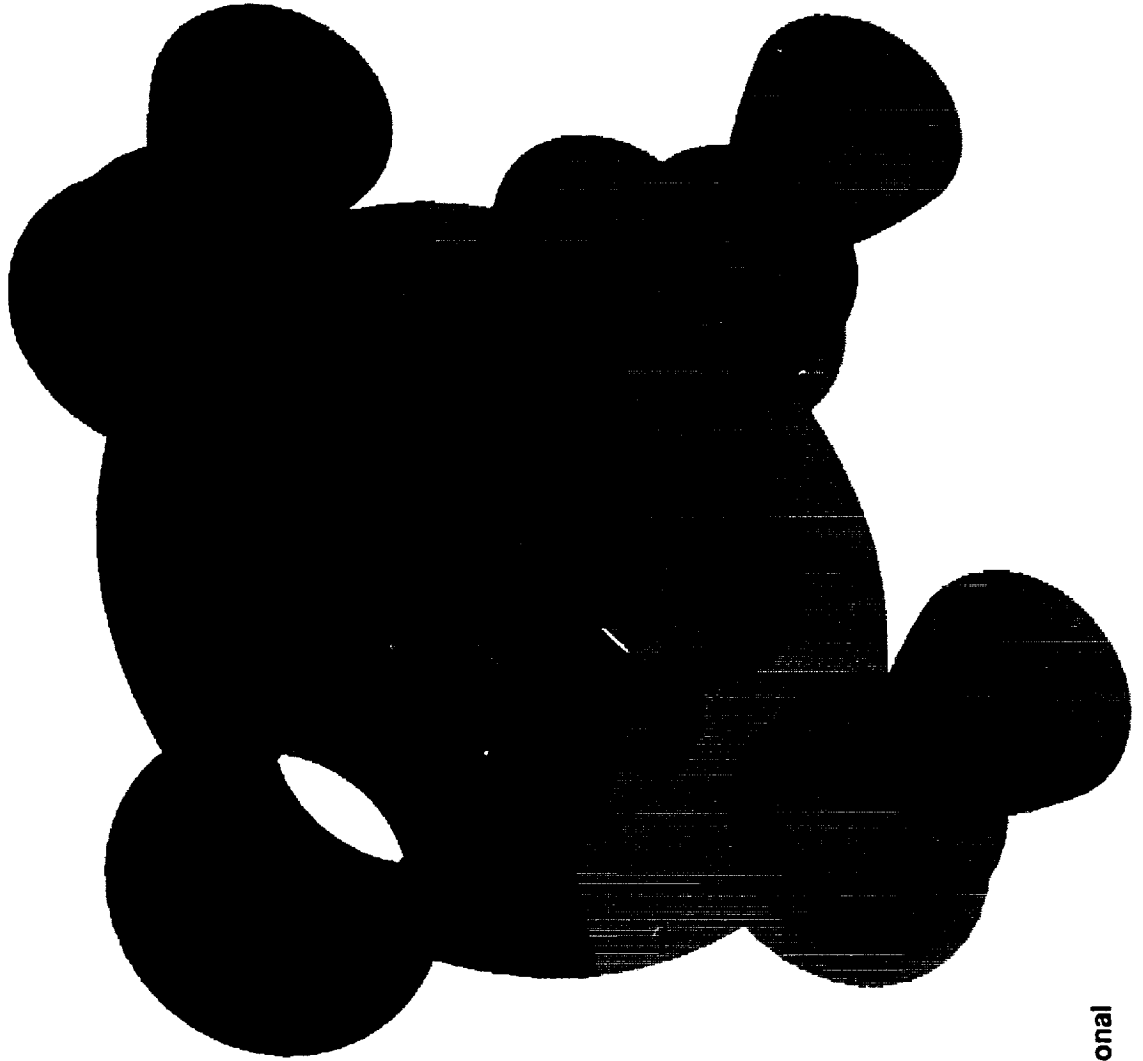

NOZZLE SURFACES TEMPERATURES

10,000 FOOT ALTITUDE

OUTER NOZZLE

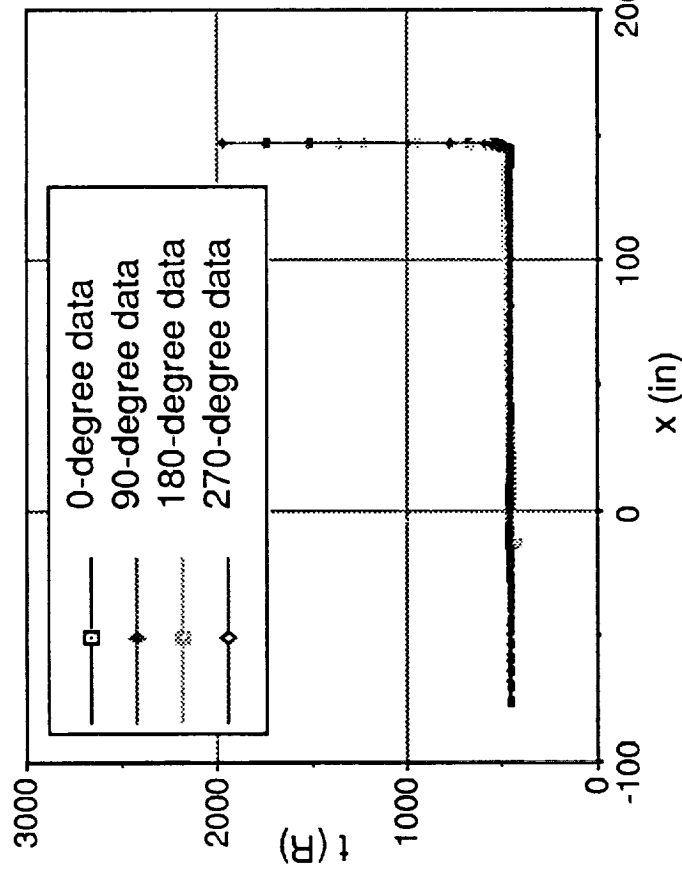

CENTER NOZZLE

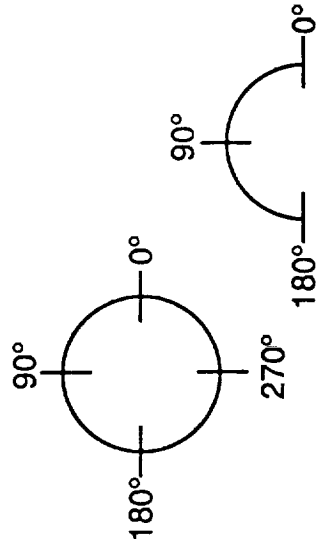
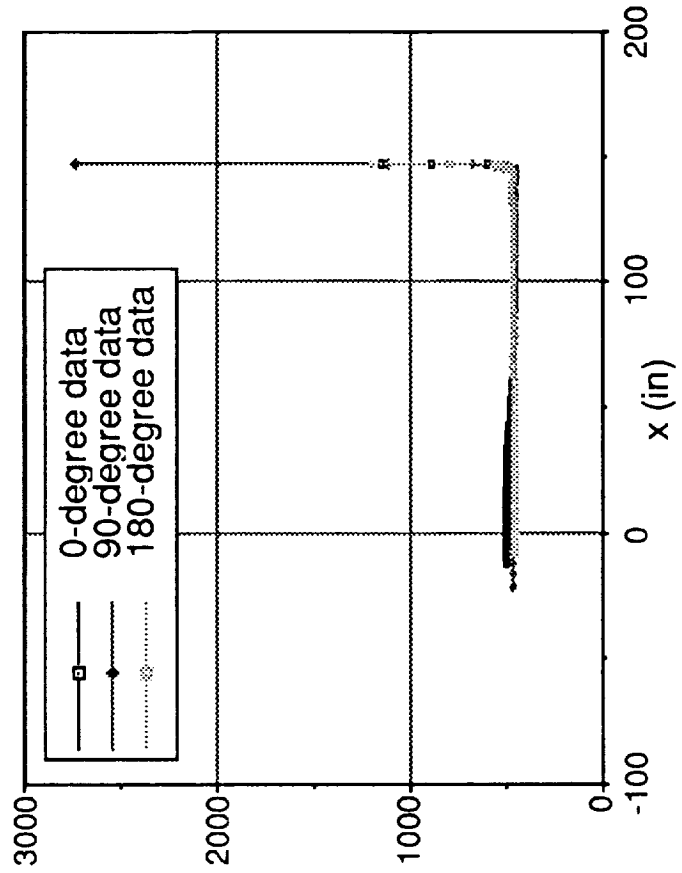

10,000 FOOT ALTITUDE RESULT SUMMARY

KEY FLOW FEATURES CAPTURED

- **PLUME STRUCTURE DEFINED**
- **PLUMES DO NOT SIGNIFICANTLY INTERACT**
- **NO MECHANISM APPARENT TO DRIVE HOT GAS INTO BASE REGION**
- **NO SIGNIFICANT AMOUNT OF H₂ OR H₂O FOUND IN BASE REGION**
- **SURFACE TEMPERATURES WELL BELOW 1000°R**
- **COARSE AND FINE GRID SOLUTIONS PREDICT ESSENTIALLY SAME FLOWS**

BASE REGION MACH CONTOURS (CONT'D)

50,000 FOOT ALTITUDE

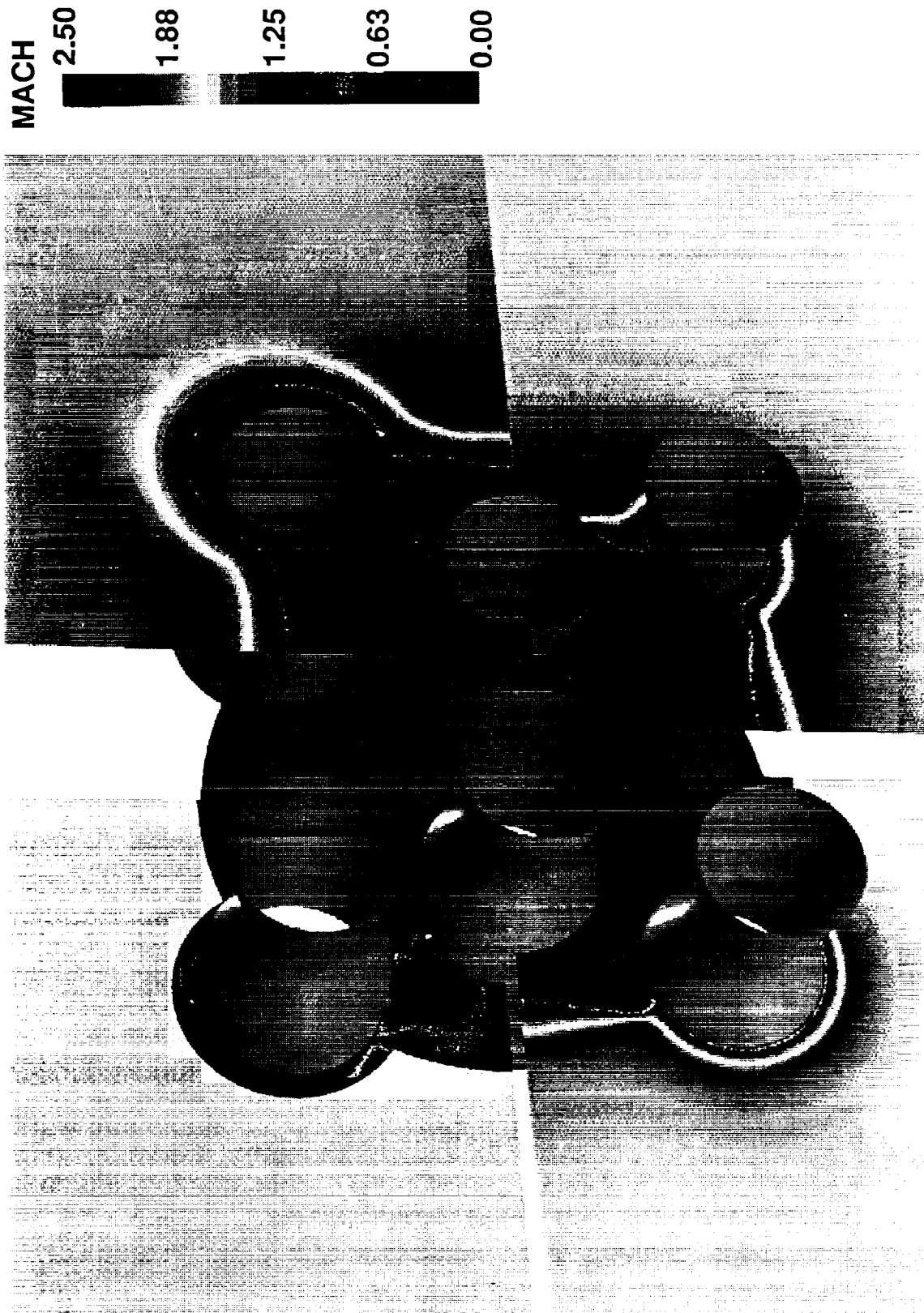

PARTICLE TRACES FROM NOZZLE EDGE 50,000 FOOT ALTITUDE

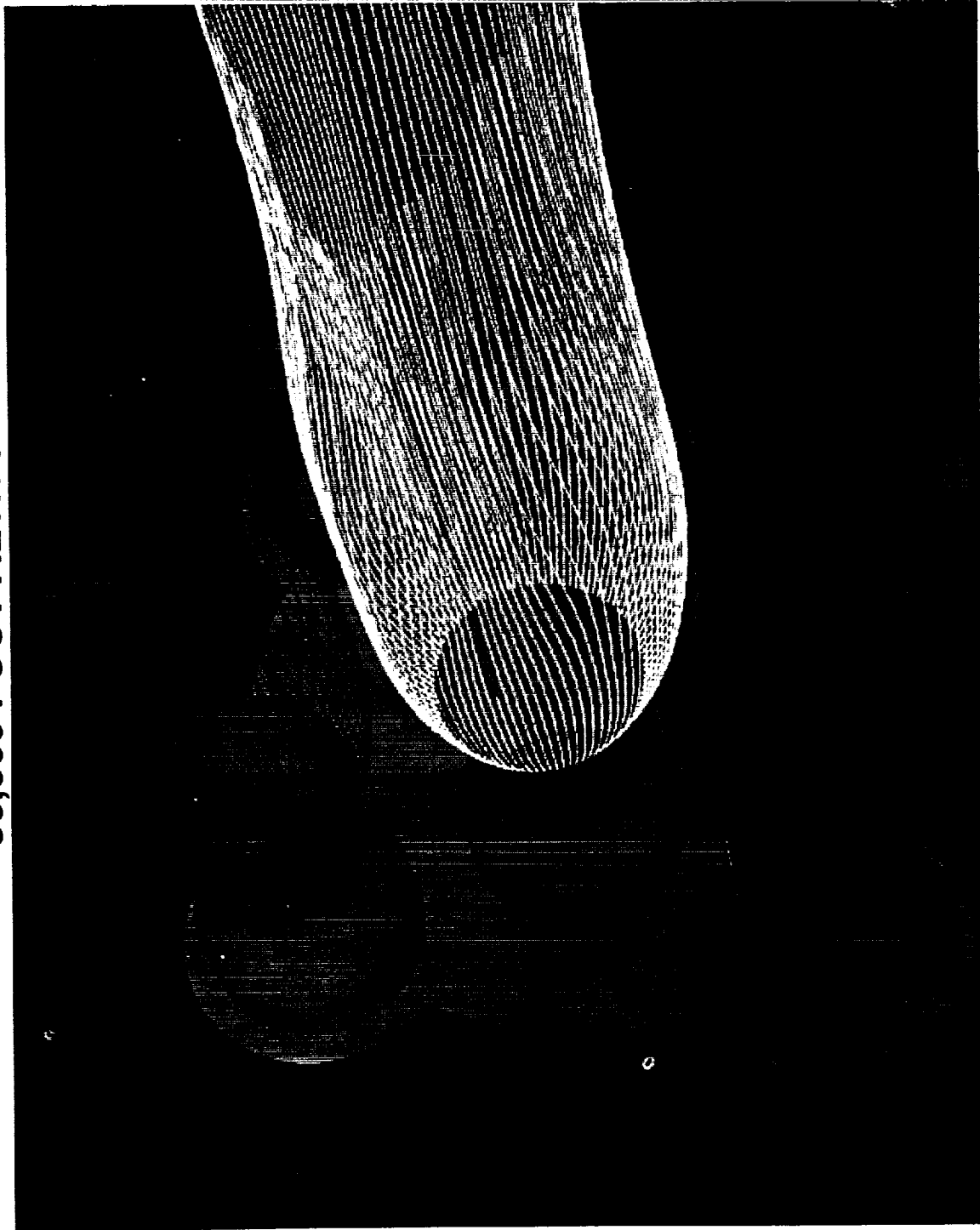

PARTICLE TRACES FROM NOZZLE EDGE (CONT'D)

50,000 FOOT ALTITUDE

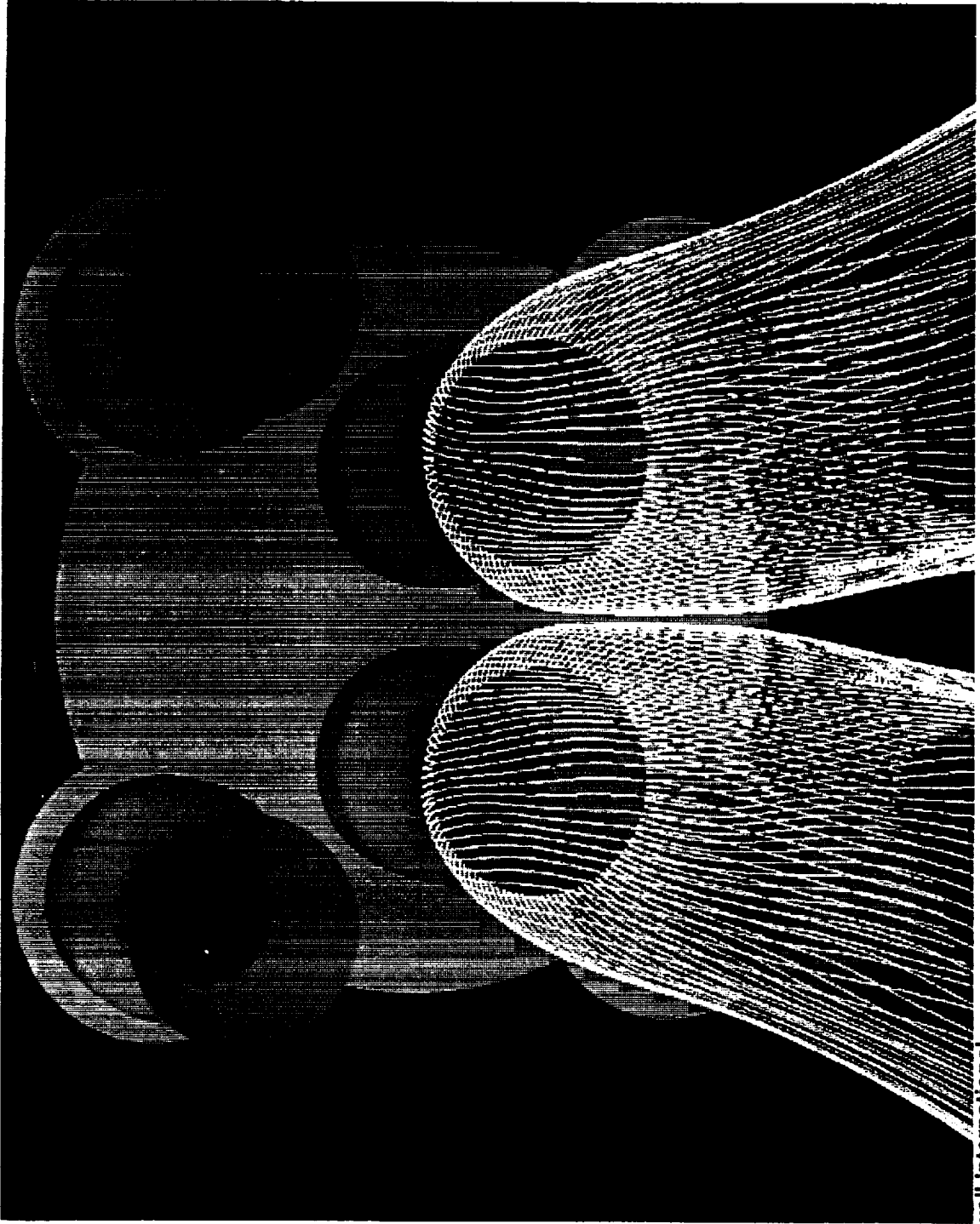

PARTICLE TRACES IN BASE REGION

50,000 FOOT ALTITUDE

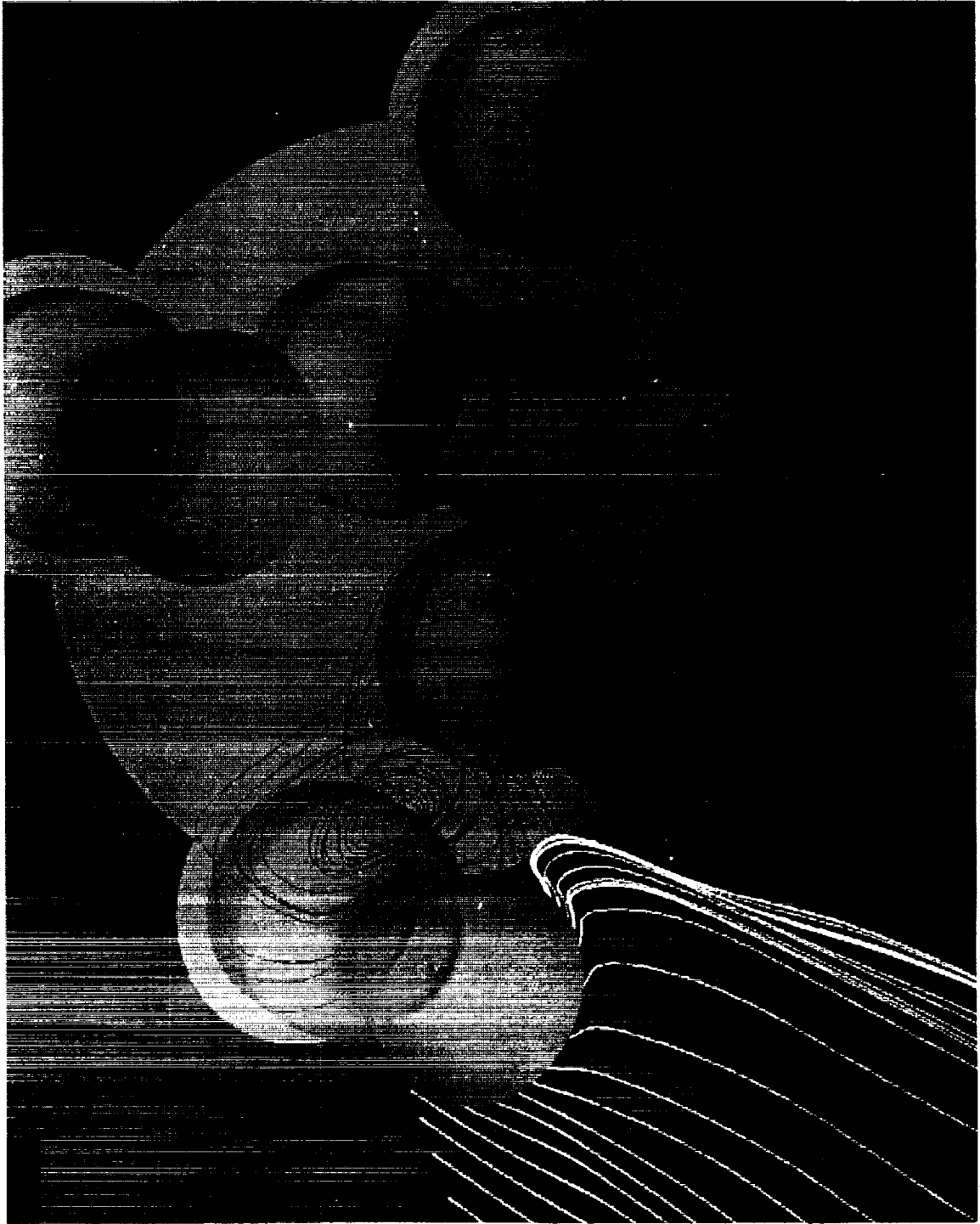

Rockwell International
Rocketdyne Division



CFD 92-042-131/03/SLB

PARTICLE TRACES IN BASE REGION (CONT'D)

50,000 FOOT ALTITUDE

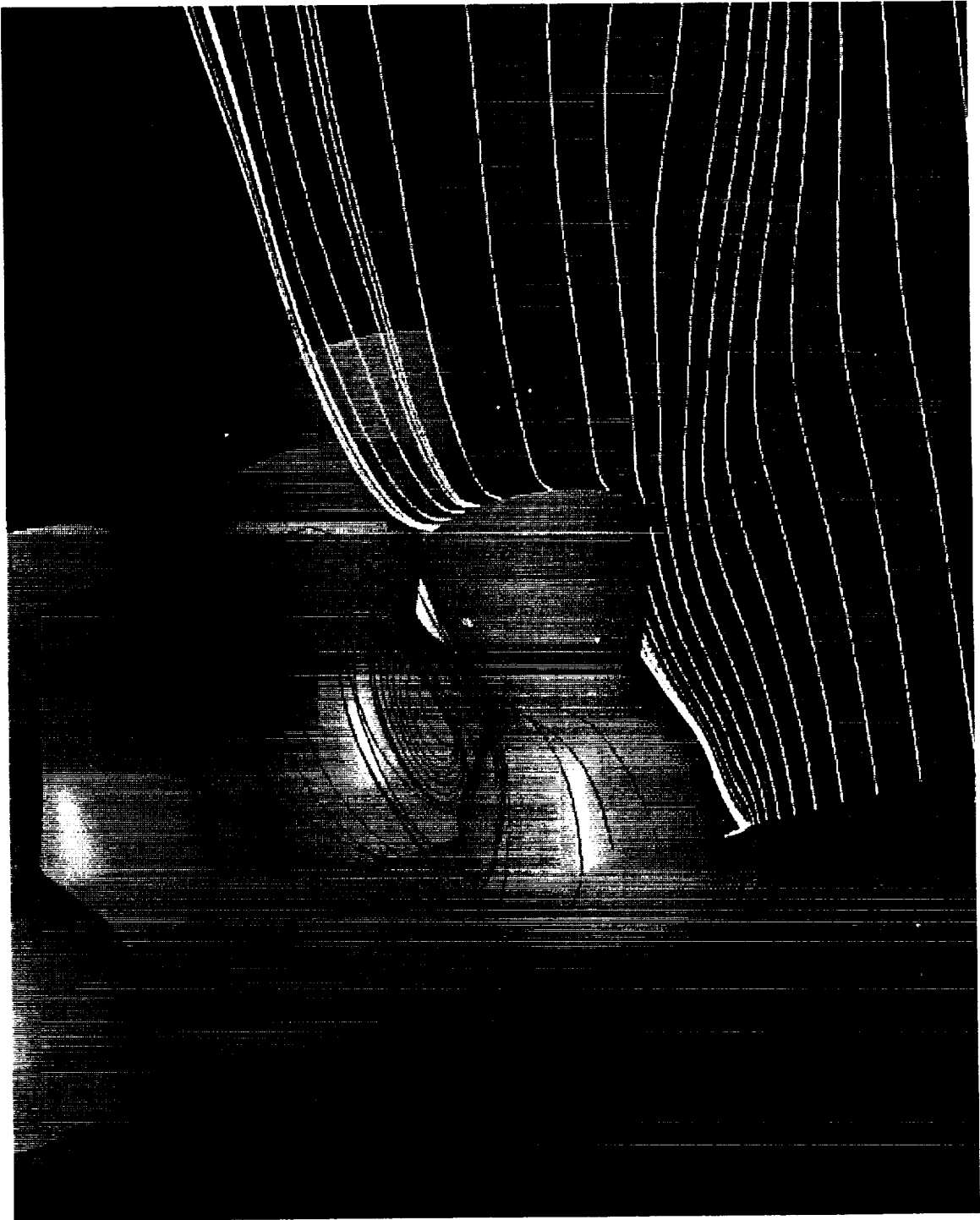

BASE REGION H2O CONTOURS (CONT'D)

50,000 FOOT ALTITUDE



BASE REGION TEMPERATURE CONTOURS (CONT'D)

50,000 FOOT ALTITUDE

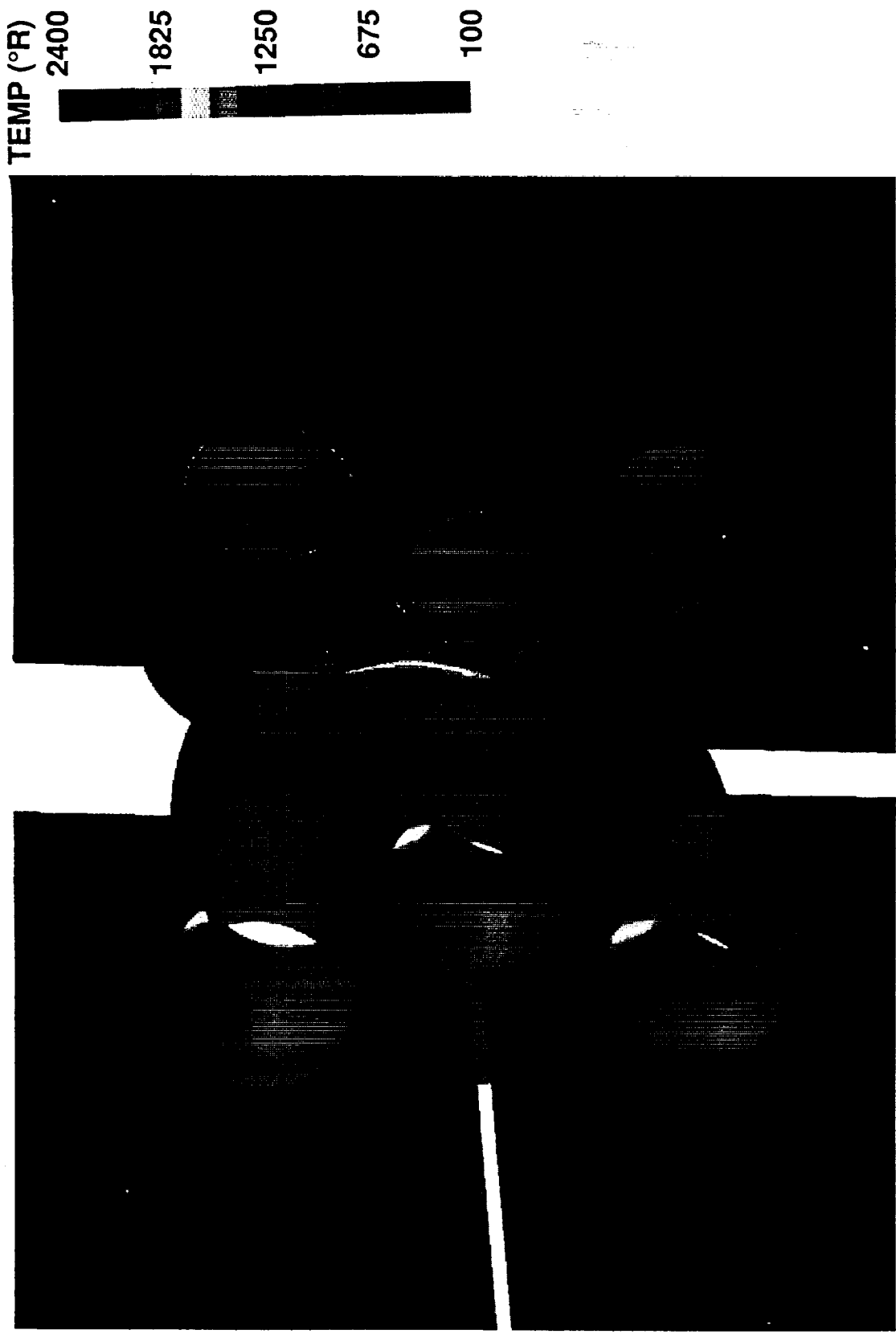

BASE REGION SURFACE TEMPERATURE CONTOURS

50,000 FOOT ALTITUDE

TEMP (°R)

1000.0

837.5

675.0

512.5

350

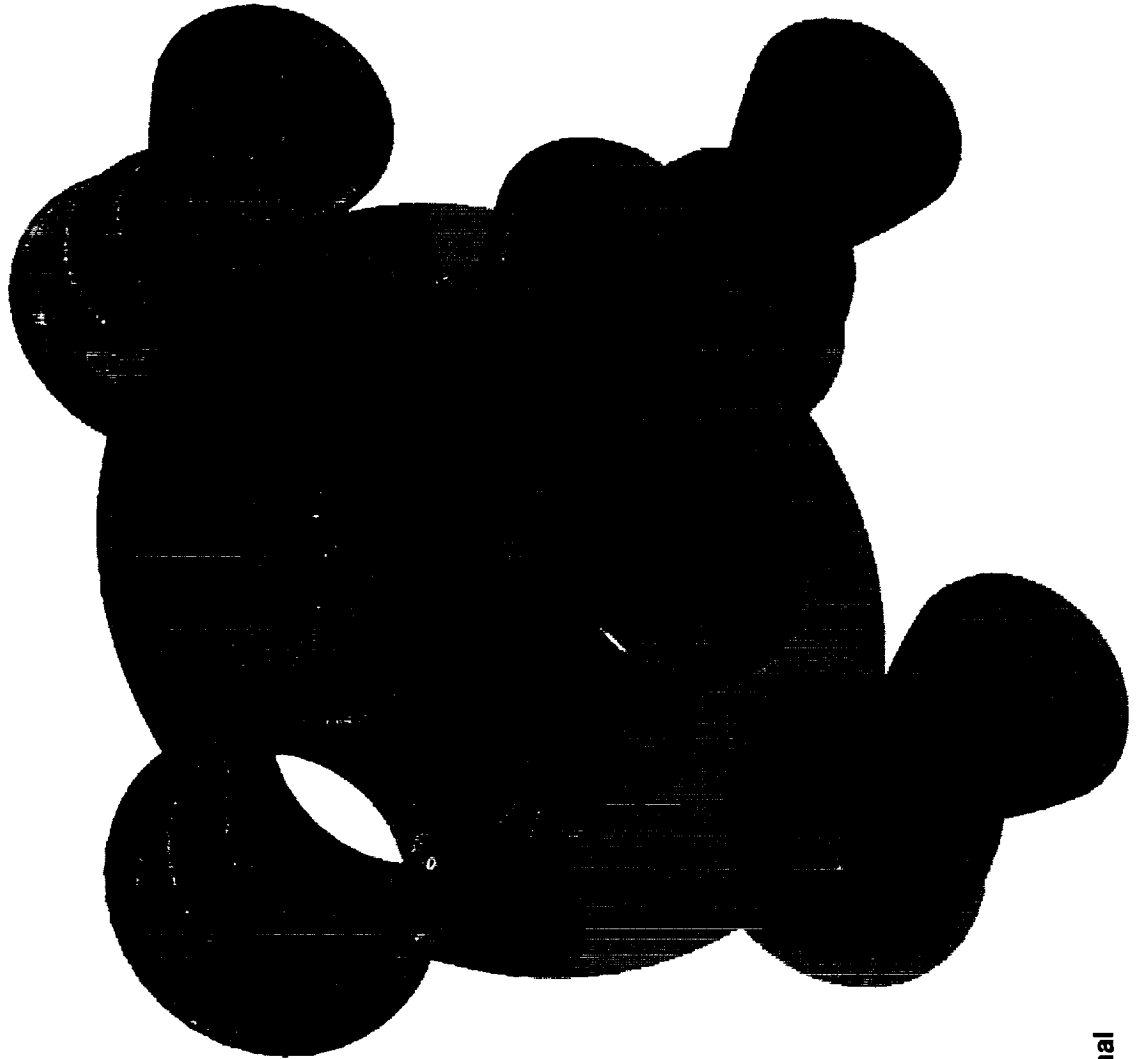

NOZZLE SURFACES TEMPERATURES

50,000 FOOT ALTITUDE

OUTER NOZZLE

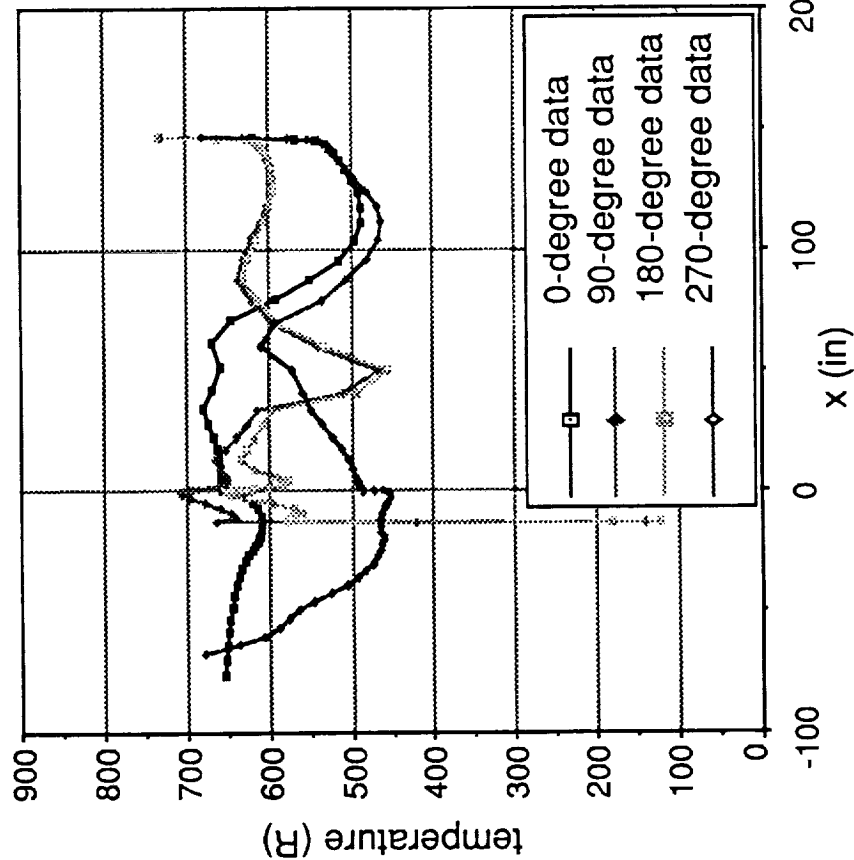

CENTER NOZZLE

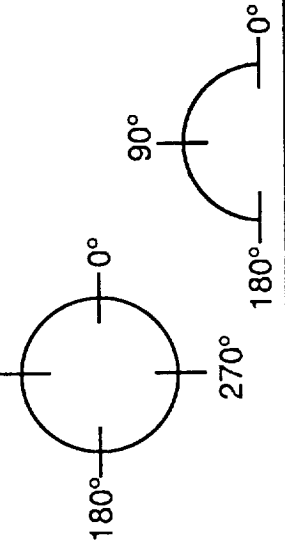
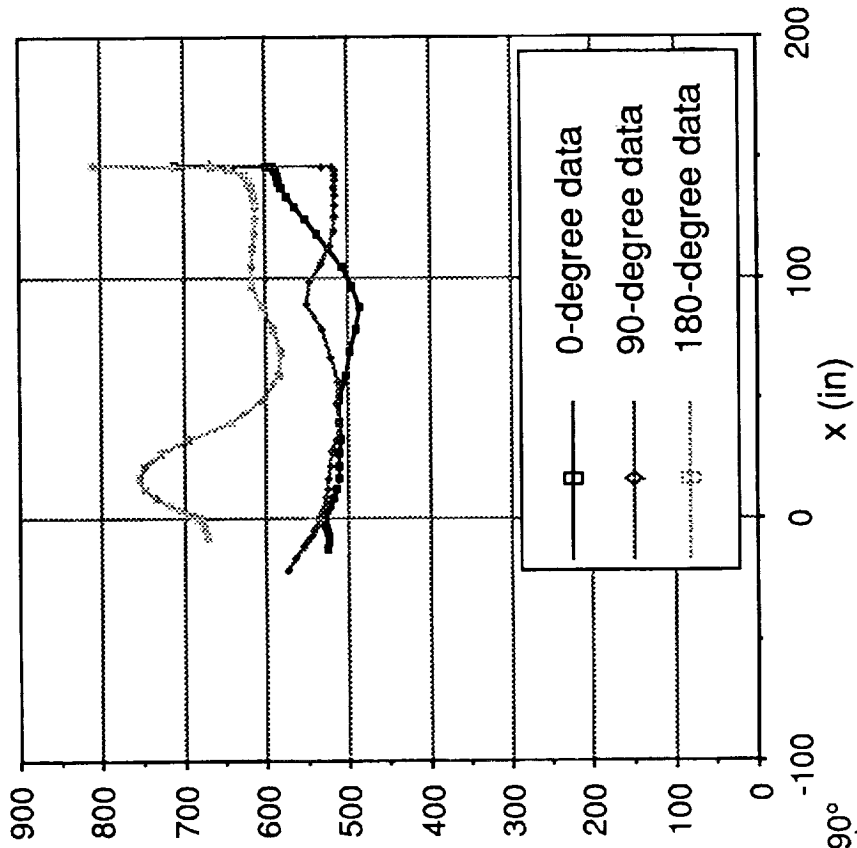

50,000 FOOT ALTITUDE RESULT SUMMARY

- **PLUME STRUCTURES DEFINED**
- **PLUME INTERACTION BECOMES SIGNIFICANT AT THIS ALTITUDE**
- **BASE GAS TEMPERATURES HIGHER THAN THOSE FOR 10,000 FOOT CASE**
- **NO SIGNIFICANT AMOUNT OF H2 OR H2O FOUND IN BASE REGION**
- **SURFACE TEMPERATURES WELL BELOW 1000°R, THOUGH WARMER THAN 10,000 FOOT CASE**

SUMMARY

- **BASE FLOW ENVIRONMENT DEFINED FOR NLS 1.5 STAGE REFERENCE GEOMETRY AT 10,000 AND 50,000 FT ALTITUDES**
- **COMPLETE PICTURE OF FLOWFIELD AVAILABLE INCLUDING VELOCITIES, PRESSURES, TEMPERATURES AND SPECIES CONCENTRATION**
- **SENSITIVITY OF RESULTS TO GRID RESOLUTION, TURBULENCE AND CHEMISTRY MODELS ASSESSED THROUGH SINGLE ENGINE PARAMETERS**
- **VALIDATION WITH AVAILABLE TEST DATA SHOWS GOOD AGREEMENT**
- **RESULTS INDICATE NO BASE HEATING PROBLEM AT 10,000 FT AND 50,000 FT ALTITUDES**
- **STUDY DEMONSTRATES ABILITY OF CFD AS A TIME EFFECTIVE ENGINEERING TOOL TO UNDERSTAND AND ASSESS BASE HEATING PROBLEMS**

