

WORKSHOP FOR CFD APPLICATIONS IN ROCKET PROPULSION**APRIL 20-22, 1993**

1995 117018

PHASE II HGM AIR FLOW TESTS IN SUPPORT OF HEX VANE INVESTIGATION

G. B. Cox, Jr.

L. L. Steele

D. W. Eisenhart

Pratt & Whitney/Government Engines & Space Propulsion
West Palm Beach, Fla.526-34
4380-1
p. 12

Following the start of SSME certification testing for the Pratt & Whitney Alternate Turbopump Development (ATD) High Pressure Oxidizer Turbopump (HPOTP), cracking of the leading edge of the inner HEX vane was experienced. The HEX vane, at the inlet of the oxidizer bowl in the Hot Gas Manifold (HGM), accepts the HPOTP turbine discharge flow and turns it toward the Gaseous Oxidizer Heat Exchanger (GOX HEX) coil. The cracking consistently initiated over a specific circumferential region of the hex vane, with other circumferential locations appearing with increased run time. Since cracking had not to date been seen with the baseline HPOTP, a fluid-structural interaction involving the ATD HPOTP turbine exit flowfield and the HEX inner vane was suspected.

As part of NASA contract NAS8-36801, Pratt & Whitney conducted air flow tests of the ATD HPOTP turbine turnaround duct flowpath in the MSFC Phase II HGM air flow model. These tests included HEX vane strain gages and additional fluctuating pressure gages in the turnaround duct and HEX vane flowpath area. Three-dimensional flow probe measurements at two stations downstream of the turbine simulator exit plane were also made. Modifications to the HPOTP turbine simulator investigated the effects on turbine exit flow profile and velocity components, with the objective of reproducing flow conditions calculated for the actual ATD HPOTP hardware. Testing was done at the MSFC SSME Dynamic Fluid Air Flow (Dual-Leg) Facility, at air supply pressures between 50 and 250 psia. Combinations of turbine exit Mach number and pressure level were run to investigate the effect of flow regime.

Information presented includes

- 1) Descriptions of turbine simulator modifications to produce the desired flow environment.
- 2) Types and locations for instrumentation added to the flow model for improved diagnostic capability.
- 3) Evaluation of the effect of changes to the turbine simulator flowpath on the turbine exit flow environment.
- 4) Comparison of the experimental turbine exit flow environment to the environment calculated for the ATD HPOTP.

**SSME ALTERNATE TURBOPUMP
DEVELOPMENT PROGRAM**

**PHASE II HGM AIR FLOW TESTS IN
SUPPORT OF HEX VANE INVESTIGATION**

**WORKSHOP FOR CFD APPLICATIONS
IN ROCKET PROPULSION**

**Marshall Space Flight Center
April 20-22, 1993**

**G. B. Cox, Jr.
L. L. Steele
D. W. Eisenhart
Pratt & Whitney/GESP
West Palm Beach, Florida**

**HPOTP TURBINE
SIMULATOR**

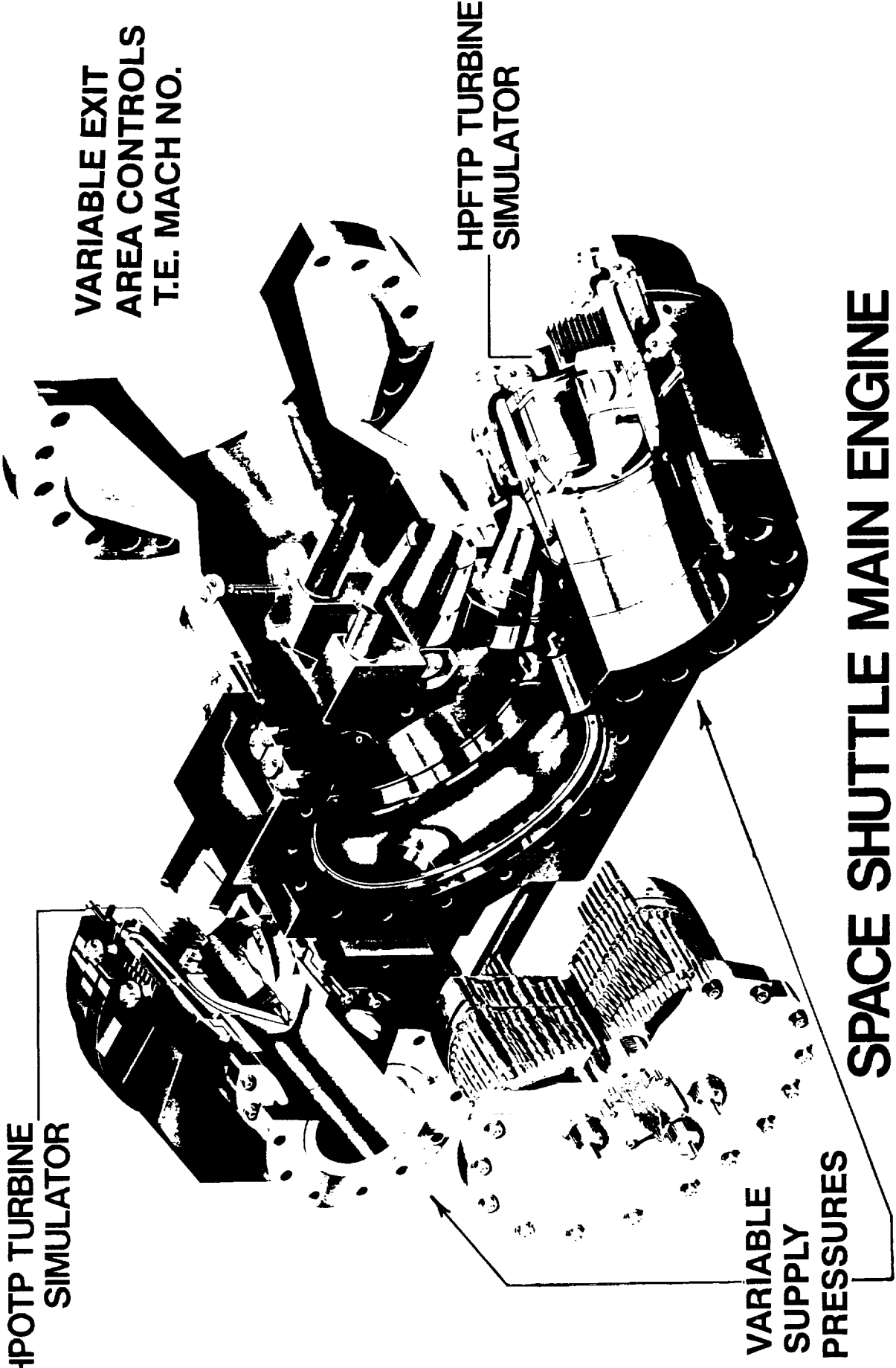

**VARIABLE EXIT
AREA CONTROLS
T.E. MACH NO.**

**HPFTP TURBINE
SIMULATOR**

**VARIABLE
SUPPLY
PRESSURES**

**SPACE SHUTTLE MAIN ENGINE
EXPERIMENTAL AIR FLOW MODEL**

TURBINE SIMULATOR/ORIFICE COMPARISON

BASELINE

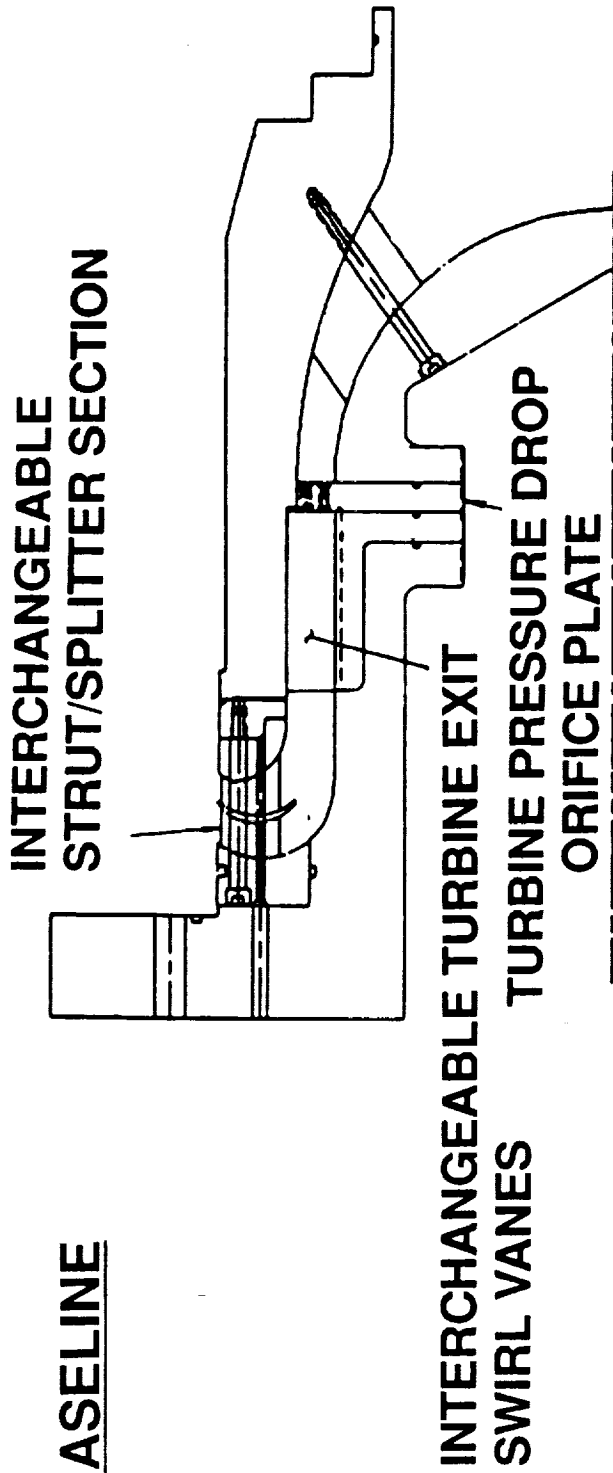

MODIFIED

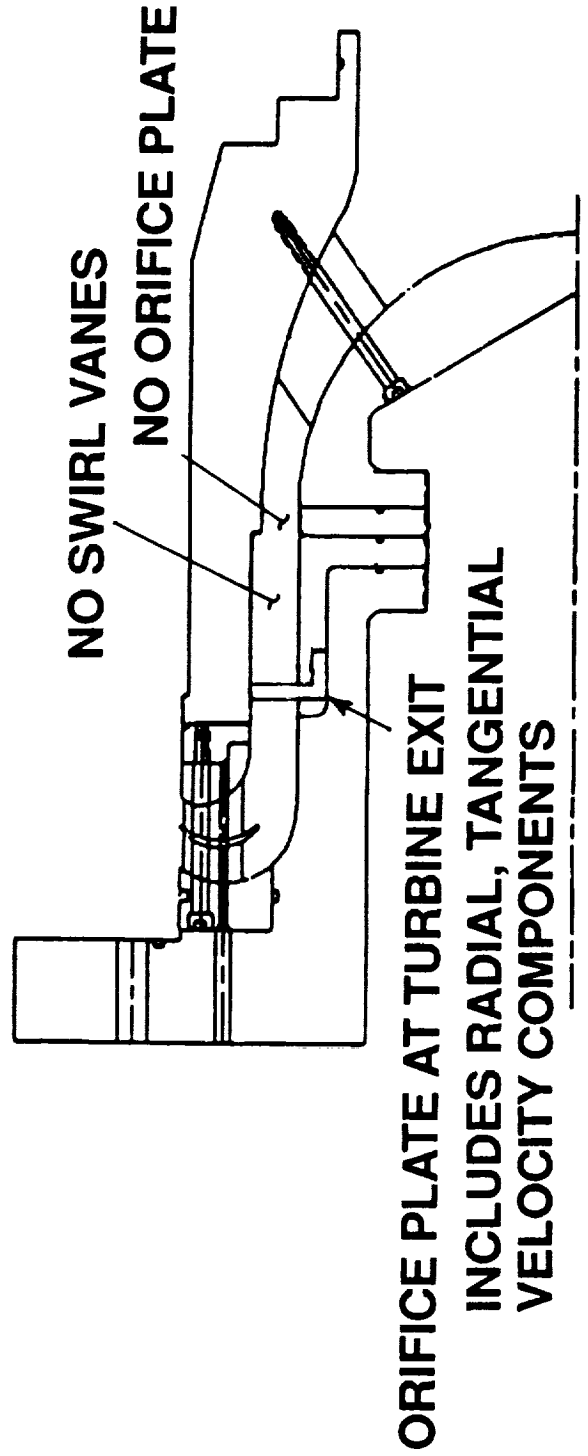

FLOW MODEL/ENGINE FLOW CONDITION DIFFERENCES

Model Tests Did Not Simulate Flow Of Final Turbine Design

ENGINE

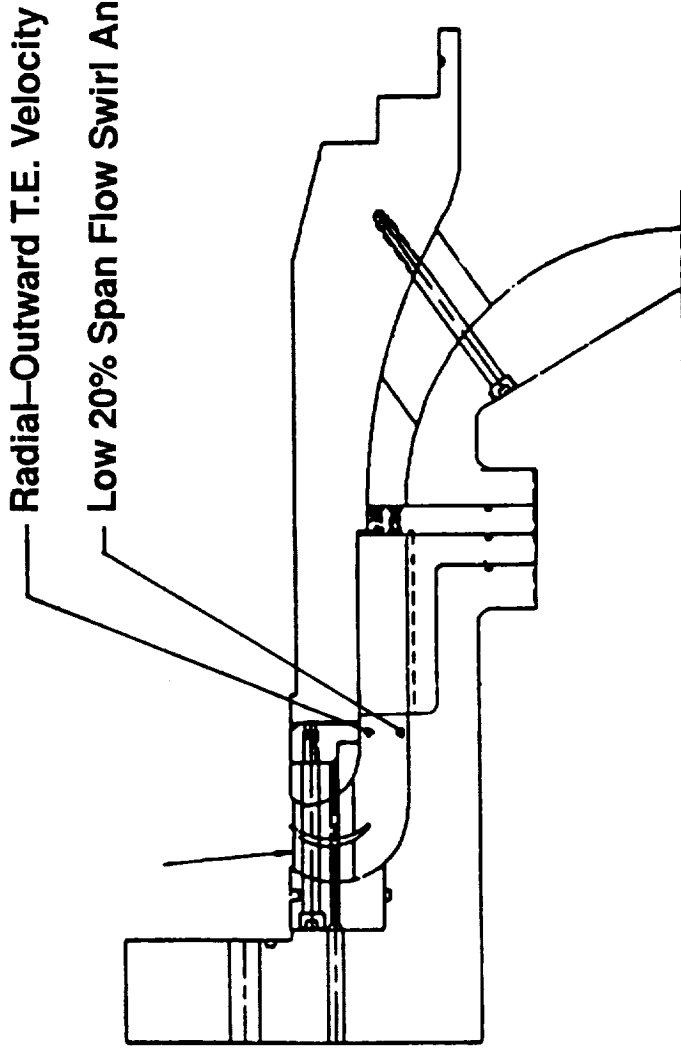

FLOW MODEL

Radial Velocity Not Matched
High 20% Span Flow Swirl Angle

ADDITIONAL HPOTP/HGM INSTRUMENTATION

Improve Definition Of Flow Environment, HEX Vane Response

HEX VANE STRAIN GAGES
FLUCTUATING PRESSURE TRANSDUCERS

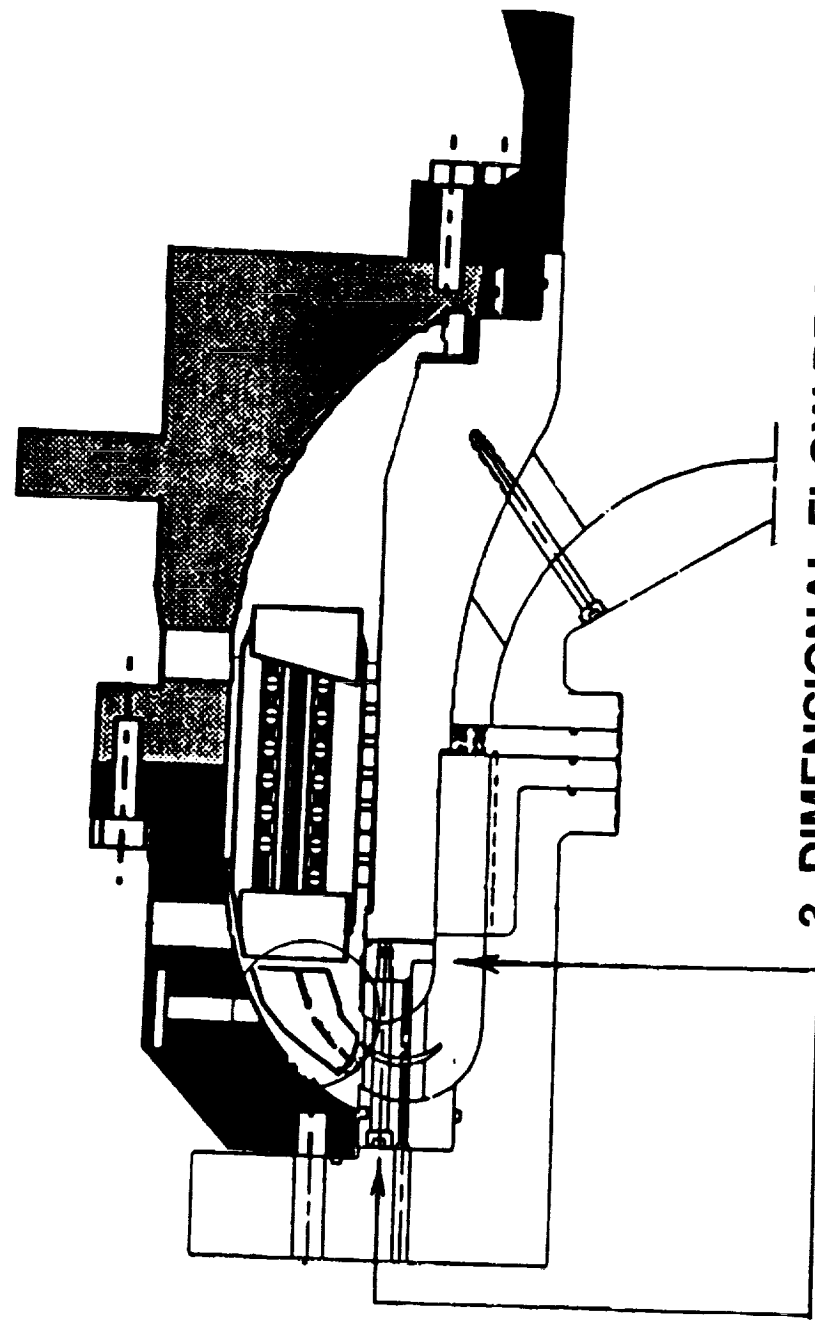

3-DIMENSIONAL FLOW PROBES

VARIATIONS OF ORIGINAL ORIFICE PLATE

Objective Was To Match ATD HPOTP Turbine Exit Flow Profile

ORIGINAL

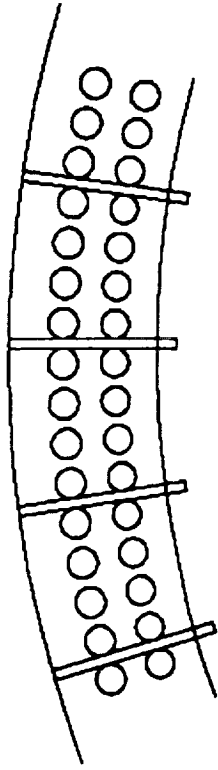

17.7% POROSITY

AXIAL FLOW

75% ORIGINAL

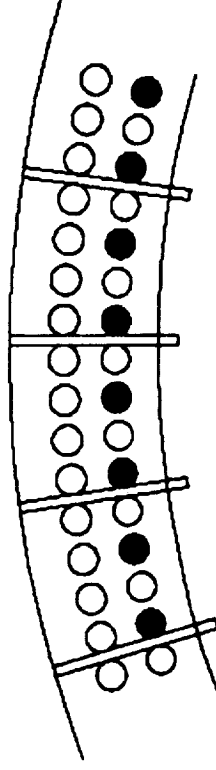

13.6% POROSITY

50% OF ID HOLES PLUGGED

LARGE AREA

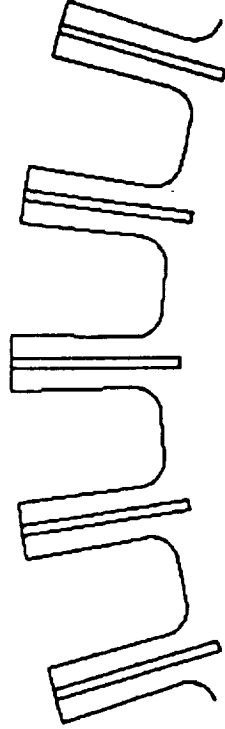

51.2% POROSITY

MATERIAL BETWEEN SWIRL
VANES REMOVED

AIR FLOW MODEL TEST CONDITION MATRIX

| | Approx. Turbine Exit Mach Number | | | | | | | | | |
|-----|----------------------------------|-----|-----|-----|-----|-----|-----|-----|-----|-----|
| | .04 | .07 | .10 | .11 | .13 | .14 | .15 | .16 | | |
| 50 | | | O,L | | | L | | | | O,L |
| 100 | | | O,L | | | L | | | | O,L |
| 150 | | | O | | | L | | | | O |
| 200 | | | O | | | | | | | |
| 250 | O | O | O,7 | O | O | O,7 | O | O | O,7 | O |

O = Original Plate

7 = 75% Plate

L = Large-Area Plate

INITIAL ORIFICE PLATE REVISIONS RADIAL PROFILES

Significant Variation in Mass Flow Profiles Obtained

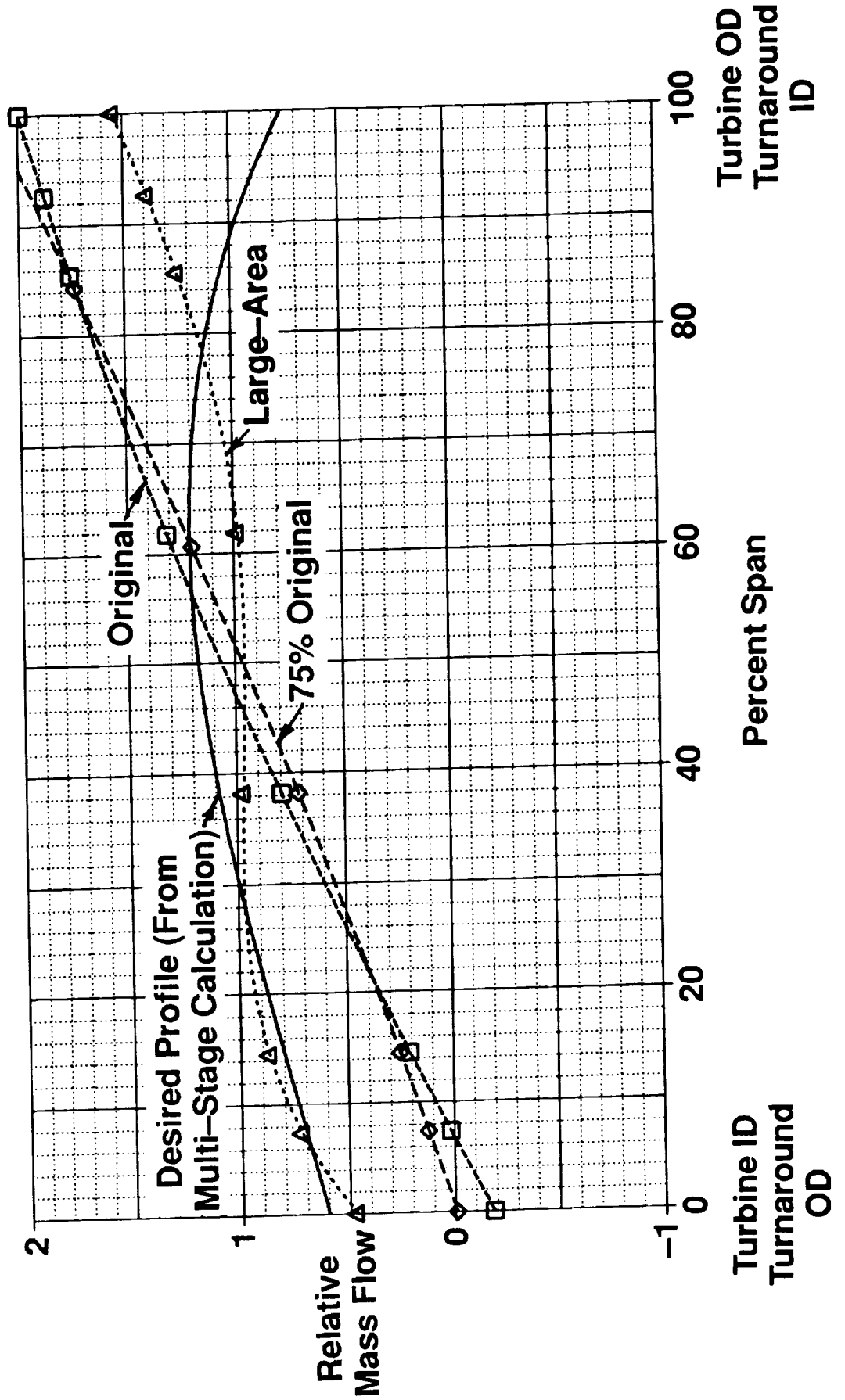

NEW ORIFICE PLATE CONFIGURATION

To Match Turbine Exit Velocity Components And Mass Profile

VIEW LOOKING UPSTREAM

Decreasing Tangential
Velocity Component
Toward OD

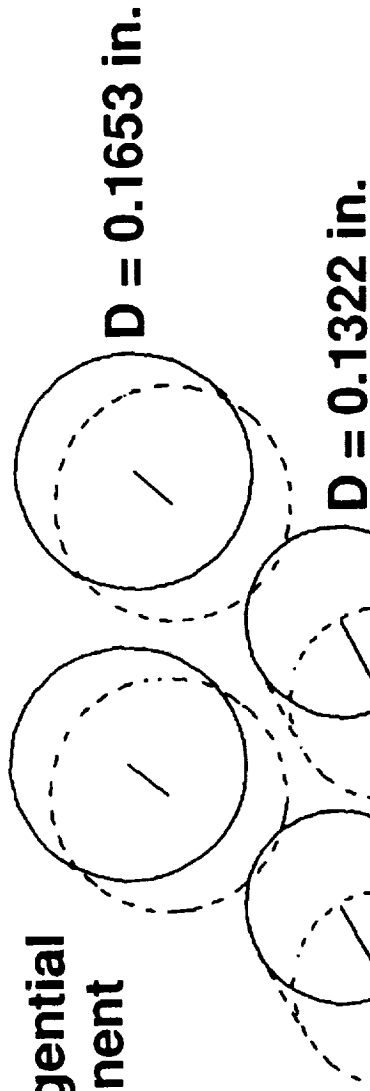

Increasing Radial
Velocity Component
Toward OD

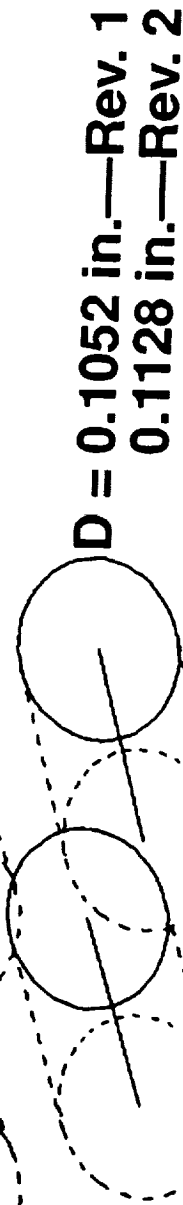

Porosity = 38.0%, Rev. 1
40.0%, Rev. 2

REVISED HPOTP TURBINE SIMULATOR FLOW PROFILES

Further Modification In Progress

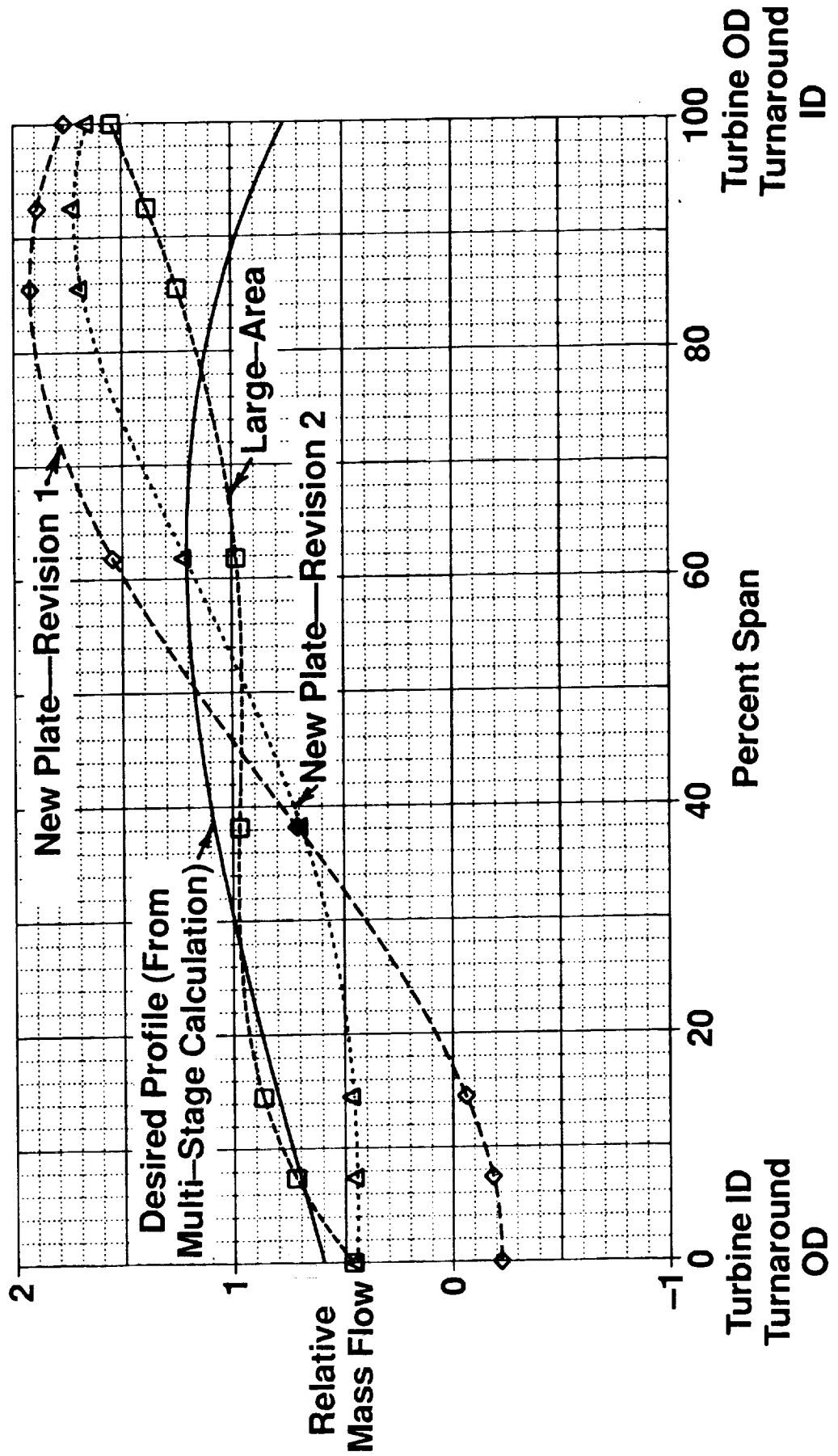

AIR FLOW TEST STATUS TO DATE

- **Test Model Shows Ability To Study Complex Flow–Related Phenomena**
- **Contractor/Government Collaboration Vital In Rapid Response**
- **Accurate Evaluation Of Configuration Changes Requires Flow Conditions Closely Matching Actual Hardware**
- **Matching Of Flow Conditions Requires Careful Attention To Flowpath Details**
- **Continued Effort With Best Match Of Engine Environment**
- **HEX Vane Stress Level And Unsteady Pressure Analyses In Progress**