

# Small Image Laser Range Finder for Planetary Rover N95-23712

Yasufumi WAKABAYASHI, Masahisa HONDA  
Tsukuba Space Center, National Space Development Agency of Japan  
2-1-1, Sengen, Tsukuba-shi, Ibaraki-ken 305, Japan  
Tel 0298-52-2241 Fax 0298-52-2247  
Tadashi ADACHI, Takahiko IJIMA  
Aerospace Division, Nissan Motor Co., Ltd.  
21-1, Matoba-Shinmachi, Kawagoe-shi, Saitama-ken 350-11, Japan  
Tel 0492-31-1113 Fax 0492-31-1116

## Abstract

Quite a few tasks remain to solve a variety of technical subjects for planetary rover navigation in the future missions. The sensors to perceive the terrain environment around the rover will require critical development efforts. The image laser range finder (ILRF) discussed here is one of candidate sensors because of many advantages to directly provide range data to be required for its navigation.

The authors developed a new compact-sized ILRF which has a quarter in volume size of those conventional ones. Instead of current two directional scanning system comprised of nodding and polygon mirrors, the new ILRF is equipped with a new concept of direct polygon mirror driving system, which successfully made its size compact to accommodate to the design requirements. The paper reports design concept and preliminary technical specifications established in the current development phase.

## 1. Introduction

The onboard sensors for Lunar or Mars rovers which will be planned in the future missions are one of the most critical elements to sense the terrain environment around the rovers. A stereo type three dimensional sensor and ILRF are most possible for the navigation system. The stereo-type three dimensional sensor system generates three dimensional terrain data from the image of onboard CCD cameras. The CCD cameras provide many advantages in various design aspects to build up the onboard sensor system. But this system needs to manage many data of the image to percept three dimensional terrain feature, so high performance computer should be required. While, the ILRF is with excellent capability to obtain three dimensional terrain geometric data within a short period of one second, which will not be influenced by the surface condition. The currently developed ILRF is equipped with a mechanical scanner for laser

beam in two dimensional directions, therefore, further development efforts must be devoted to improve its design features such as reliability, weight, size, power consumption to be onboard space hardware. In practical missions, the ILRF may be utilized in cooperation with the stereo system.

## 2 System Outline

The ILRF sensor onboard the rover will be utilized to collect the terrain information in front of the rover, which will require high accuracy and high frame rate performance. This requirements lead us to the conclusion to a methodology of phase-comparison system utilizing intensity-modulated CW laser. The concept of this methodology is shown in Figure 1.

The laser beams are radiated to the objects, which will reflect the beams with some phase shift proportional to distance up to a radiated point. And then the resultant amount of phase

shift shall be obtained to compare with the reference to determine the distance between the rover and targeting points.

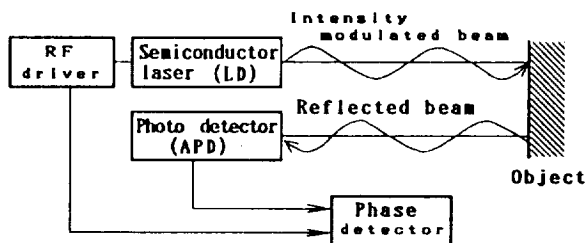

Figure 1 Concept of range measurement

Thus optical scanning in two dimensional directions helps to obtain three dimensional terrain geometric data. The optical system consists of a polygon mirror and two collecting mirrors. The object of our efforts is to realize the compactness without degrading measuring performance. The resultant concept of the optical system is shown in Figure 2.

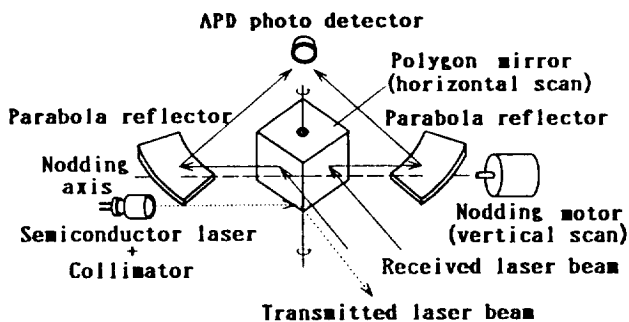

Figure 2 Concept of the optical system

Downsizing effort on polygon mirror was made by means of receiving the beam at the two facets of the polygon mirror (with four facets) for horizontal scanning instead of one facet and the nodding mirror which was eliminated by directly driving the polygon mirror in vertical direction. An incident laser beam is split into two directions by the two facets of polygon mirror, and each beam is directly focused on a detector by parabola reflectors set up symmetrically. Thus, the collecting lenses can be eliminated, which enable to minimize the optical system as a design feature. The standard sensing circuit is used in our ILRF as shown in Figure 3. The intensity of the semiconductor laser is modulated in a 10.7MHz frequency, the reflected beam from the object received by an APD detector. The output signal received by the detector passes into the detection circuit of range and reflectance. The range is determined by the phase difference of measuring signal and referential signal. In order to obtain sufficient sensitivity and accuracy, nearly 100 waves are respectively integrated for each range data. The data of range and reflectance are converted into digital data by an A/D converter. All of these data are sent to a signal processor for the terrain perception.

### 3. Performance improvement

The conventional laser range finders are still with problems with respect to its performance. The efforts in improving its performance were devoted to sensor as follows.

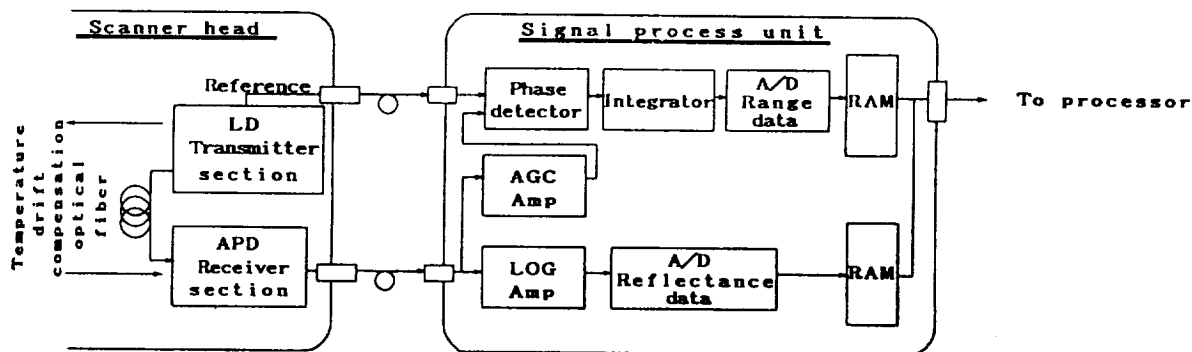

Figure 3 Block diagram of sensing circuit

(1) Protection of internal reflection of laser beam

The transmitted laser beams in some directions are reflected at the window as shown in Figure 4(a) and these make the ghost in the range and reflectance images. Essentially, it is difficult to eliminate this reflection since the reflected laser beam at the window is larger than return signal from the object. We set the cylindrical window with the same surface curvature center with the pitch gimbal pivot for vertical scanning, and a complete screening plate as shown in Figure 4(b) can be set to split the laser beam transmitting part from the receiving optics for eliminating the ghost image.

(2) Compensation of range drift caused by temperature changes

The measured ranges might be mostly unstable due to changes of environment

temperature with respect to a conventional laser range finder. The newly developed ILRF was no exceptional for this drift phenomena. In order to compensate the possible drift, the laser beam is led to the APD detector through a optical fiber cable with a reference length in no outside sensing period. This enables to measure drift rate in reference to the predetermined length and then, the compensation for correcting the data is executed with respect to all measurement range data. The schematic diagram of processing is illustrated in Figure 5.

#### 4. Characteristics of ILRF

The current ILRF configuration is given in Figure 6, and the characteristics in Table 1. Figure 7 shows ranging and reflectance image to be obtained through the ILRF sensor.

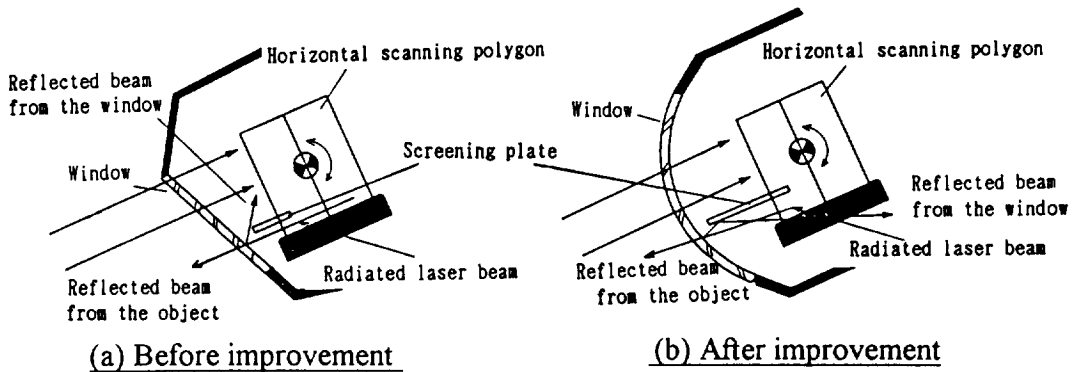

Figure 4 Protection concept for laser beam inner reflection

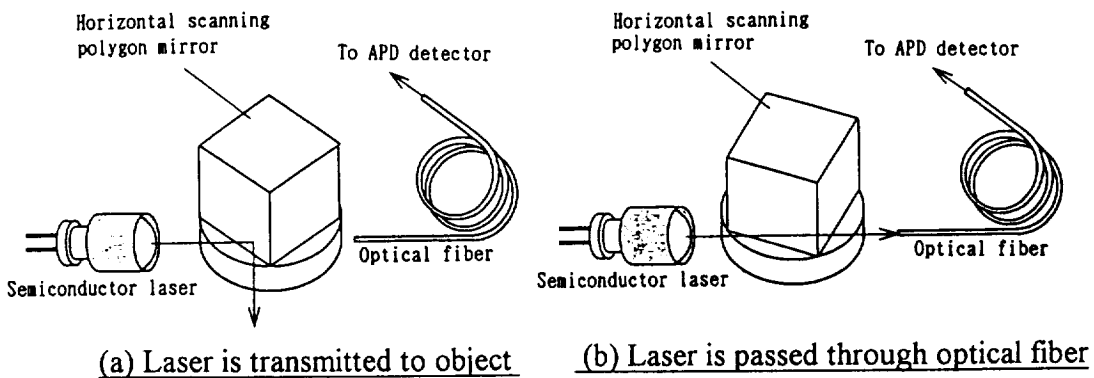

Figure 5 Compensation method of the range drift by temperature change

## 5. Conclusion

The image laser range finder reported in this paper still require improvement in order to secure more sufficient reliability especially for a mechanism of the scanner. However, the authors have successfully achieved to develop a more compact-sized laser range finder with satisfactory function and performance in the current development phase. The state-of-the-art proven in the report is believed to enhance the design-in and design-out efforts for more practical terrain sensor in the very near future. Our ILRF has been developed in cooperation with Corporate Research Division Olympus Optical Co.,LTD.

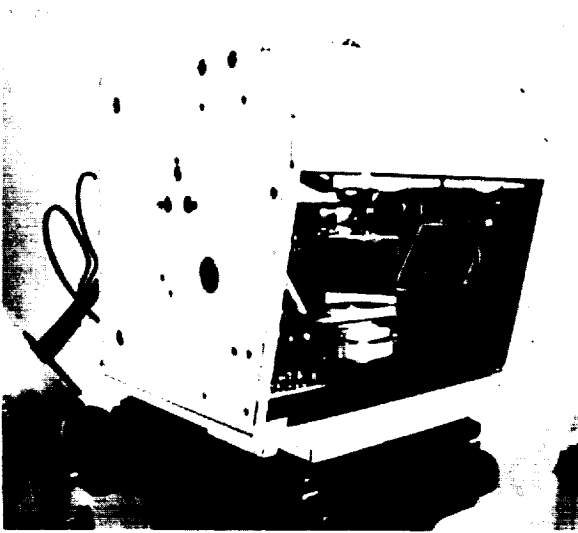

Figure 6 Configuration of the ILRF

Table 1 Characteristics of ILRF

Data details	2D Reflectance Image 2D Range Image
Field of view	80° (horizontal) × 40° (vertical)
Space resolution	256(horizontal) × 64(vertical)
Range	1.5m~14m
Modulation frequency	10.7MHz
Frame interval	1 sec
Size of scanning head	150 × 150 × 150 mm <sup>3</sup>
Weight of scanner head	about 3kg
Range resolution	12Bit
Intensity resolution	12Bit
Laser power	60mW
Consumption power	80W (24V input)

## Reference

[1] Max E.Bair et al., "Three-dimensional image and applications" SPIE Vol. 726 Intelligent Robot and Computer Vision: Fifth in a Series PP264-274, 1986.

[2] In So Kweon et al., "Experimental Characterization of the Perception Laser Rangefinder" Technical Report CMU-RI-TR-91-1 Robotics Institute, Carnegie Mellon University January 1991.

[3] Lu Zukong et al., "Range Imaging for Auto-Vehicle Guidance Applying an optical Radar" SPIE Vol. 1831 Mobile Robots VU PP456-456, 1992.

[4] J.Richard Kerr et al., "Real time imaging rangefinder for autonomous land vehicle" SPIE Vol. 1007 Mobile Robots III PP349-356 1988.

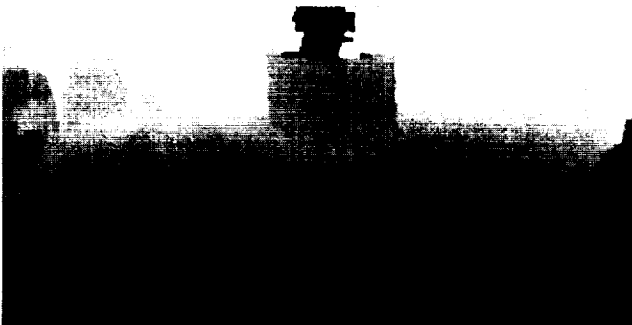

Ranging image



Reflectance image

Figure 7 Range and reflectance image pair of ILRF