

44582  
18P

NASA Contractor Report 190787

# Predicted Performance of an Integrated Modular Engine System

Michael Binder and James L. Felder  
*Sverdrup Technology, Inc.*  
*Lewis Research Center Group*  
*Brook Park, Ohio*

N95-23791

Unclass

G3/20 0044582

July 1993

Prepared for  
Lewis Research Center  
Under Contract NAS3-25266

(NASA-CR-190787) PREDICTED  
PERFORMANCE OF AN INTEGRATED  
MODULAR ENGINE SYSTEM Final Report  
(Sverdrup Technology) 18 p



National Aeronautics and  
Space Administration



# Predicted Performance of an Integrated Modular Engine System

Michael Binder  
and  
James L. Felder  
Sverdrup Technology, Inc.  
Lewis Research Center Group  
2001 Aerospace Parkway  
Brook Park, Ohio 44142

*This work was performed under contract NAS3-25266, NASA Lewis Research Center.*

## Abstract

Space vehicle propulsion systems are traditionally comprised of a cluster of discrete engines, each with its own set of turbopumps, valves, and a thrust chamber. The Integrated Modular Engine (IME) concept proposes a vehicle propulsion system comprised of multiple turbopumps, valves, and thrust chambers which are all interconnected. The IME concept has potential advantages in fault-tolerance, weight, and operational efficiency compared with the traditional clustered engine configuration. The purpose of this study is to examine the steady-state performance of an IME system with various components removed to simulate fault conditions. An IME configuration for a hydrogen/oxygen expander cycle propulsion system with four sets of turbopumps and eight thrust chambers has been modeled using the ROCKET Engine Transient Simulator (ROCETS) program. The nominal steady-state performance is simulated, as well as turbopump, thrust chamber and duct failures. The impact of component failures on system performance is discussed in the context of the system's fault tolerant capabilities.

## Glossary of Terms

AETB	Advanced Expander Test Bed Engine
FTP	Fuel Turbopump
FPDM	Fuel Pump Discharge Manifold
FTBV	Fuel Turbine Bypass Valve
FTDM	Fuel Turbine Discharge Manifold
HXDM	Cooling Jacket Discharge Manifold
LOX	Liquid Oxygen
MTBV	Main Turbine Bypass Valve
OTP	Oxidizer Turbopump
OPDM	Oxygen Pump Discharge Manifold
OTDM	Oxidizer Turbine Discharge Manifold
TC	Thrust Chamber Assembly
$\phi$	Pump Flow Coefficient
$\phi_{stall}$	Pump Flow Coefficient at onset of Stall ( $\phi$ at maximum Head Coefficient)

## Introduction

Historically, most American rocket propulsion systems have been comprised of one or more discrete engines, each with its own set of pumps, turbines, valves, and a thrust chamber. The engines in such a configuration are not tightly interconnected but work separately. Recently, a different propulsion concept has been suggested wherein the system is composed of a common set of turbopumps, valves and thrust chambers, all interconnected by manifolds. This configuration is referred to as an Integrated Modular Engine (IME). The IME concept offers potential advantages in reliability, cost and weight. Each of these advantages must be verified carefully before resources are committed to developing such a system.

The potential reliability advantage of the IME stems primarily from its fault tolerant capability. In the traditional cluster of discrete engines, when a major component of an engine fails, the entire engine must be shut down, including those components which have not failed. In an IME system, it may be possible to shut-off a failed

component without requiring the shutdown of other system components. To be considered truly fault tolerant, the IME system should be capable of maintaining full thrust despite a component failure. This would require that operation of the other components in the system be adjustable to compensate for the loss of the failed component. The feasibility of fault tolerant operation has not previously been explored in detail. Although propulsion systems in which multiple thrust chambers operate from common turbopumps have been flown before (the Atlas boost stage and a number of Russian vehicles), these systems use integrated system designs for reasons other than fault tolerance. The fault tolerance of such integrated designs has never been demonstrated. The purpose of the modeling effort discussed in this paper is to provide quantitative information about the operation of an IME system when various components are lost. A statistical analysis of IME reliability is presented in a separate paper.<sup>1</sup>

A steady-state system model of an IME has been created using the Rocket Engine Transient Simulator (ROCETS) program. ROCETS is a general purpose system modeling code capable of both steady-state and transient simulation.<sup>2</sup> The IME configuration modeled here is a cryogenic hydrogen/oxygen expander cycle made up of four fuel turbopumps, four oxygen turbopumps, and eight regeneratively cooled thrust chambers (Figure 1). The system is designed to provide a nominal thrust of 80,000 lbf (35586 N). The basic configuration of the system is similar to those proposed in previous studies<sup>3</sup> to provide a basis for comparison. The thrust level was selected to meet anticipated upper stage application requirements. The number of combustion chambers (eight) was selected to provide adequate thrust balance in the event of component failure. The number of turbopump sets (four) was selected to take advantage of the existing component designs generated in the Advanced Expander Test Bed (AETB) program.<sup>4</sup> Component redesign and analysis were performed, when necessary, at NASA Lewis using steady-state component computer codes.<sup>5, 6</sup>

Using this model of the IME, the effects of component failure on system operation are calculated. The failures considered include loss of fuel and/or oxidizer turbopumps, loss of thrust chambers, and leaks in the various distribution manifolds. The computer model is used to predict the changes in system operation that are required to maintain desired thrust despite component failure. The resultant changes in pump stall-margins and throttling capacity observed in the model will help assess the fault-tolerance of this IME system. The results of this study also provide important

information for further component design iterations to improve system fault-tolerance. Descriptions of the component and system models are presented below, followed by a discussion of the analysis results.

### Description of IME Model

The IME system design depicted in Figure 1 is based on a study being conducted at NASA Lewis Research Center to determine methods for physically assembling an IME.<sup>7</sup> This design is a full-expander cycle, which means that the total hydrogen fuel flow passes through the nozzle and chamber cooling jackets. The warmed hydrogen is used to drive the turbopumps, and is then injected into the combustion chamber. The IME design in Figure 1 implements full-expander operation as follows. Liquid hydrogen from the tanks is supplied to the four fuel pumps in parallel. The fuel pumps discharge into a manifold (FPDM), which feeds the eight parallel cooling jackets. The cooling jacket flows are collected in the next manifold (HXDM) and distributed to the four parallel fuel turbines, which drive the fuel pumps. The fuel turbine discharge flows are then collected in a third manifold (FTDM) and distributed to the four parallel oxidizer turbines, which drive the LOX pumps. Finally, the fuel is collected once more (in the OTDM) and distributed to the eight thrust chambers. The oxidizer follows a much less circuitous route, flowing from the tank(s) through the four parallel LOX pumps and into the OPDM. The oxidizer is then distributed to the eight thrust chambers. Each turbopump and thrust chamber assembly in the system has associated inlet and exit shut-off valves, which isolate that component from the rest of the system in the event of a failure. In addition to the shut-off valves, there are two system control valves. The main turbine bypass valve (MTBV) is used to control system thrust level. The fuel turbine bypass valve (FTBV) is used to maintain LOX pump discharge pressures at low thrust levels. In its present configuration, the system is not designed to control thrusts in the eight chambers independently. This *differential throttling* capability could be accomplished, if desired, by replacing the fuel and oxidizer injector shut-off valves with control valves instead. This would, however, increase the complexity of the controller logic and the valve actuator system.

Each fuel turbopump (Figure 2) has three pump stages and two turbine stages. The first-stage

fuel turbine drives the first-stage fuel pump (shaft 1), while the second-stage turbine drives the second and third stage pumps (shaft 2). Each oxidizer turbopump (Figure 3) consists of a single turbine driving a single LOX pump. The nozzle cooling circuit is made up of tubular channels while the chamber employs milled channels closed off by a metal skin. The LOX injector uses a dual orifice design similar to that used in the AETB.<sup>4</sup>

All valves and ducts in the system, with the exception of the fuel shut-off valves and fuel injectors, are modeled with non-inertial incompressible flow correlations. The distribution manifolds are represented as simple non-resistive volumes. Pump performances are represented as tables, or *maps*, of head coefficient and efficiency versus flow coefficient.<sup>8</sup> Turbine performances are represented as bivariate maps of flow parameter (related to resistance) versus pressure ratio and reduced speed<sup>8</sup>, and by maps of efficiency versus velocity ratio.<sup>8</sup> The maps for the first stage fuel pump and the LOX pump are the same as those used for the AETB system, while the second and third stage fuel pump maps and all turbine maps have been redesigned.<sup>5,6</sup> The design changes were necessary because the IME is a full-expander cycle while the AETB is a split-expander (where a large fraction of the fuel flow from the first stage pump is bypassed around the cooling jackets and turbines). Chamber and nozzle performances are based on empirical tables and equations relating chamber pressure, propellant flow, mixture ratio, and thrust. Cooling jacket performance is calculated using Bartz correlations for the hot-side heat transfer<sup>9</sup> and using Colburn correlations for the cool-side transfer.<sup>10</sup> Although the sizes and shapes of the IME chambers and nozzles have been changed from those in the AETB, that model's nozzle performance and heat-transfer correlations can still be applied.

The model is solved under the ROCETS system using an iterative Newton-Raphson matrix solver.<sup>2</sup>

### Results of Analysis

In this study, the effects of various component failures on system performance are examined. Ten scenarios were considered in all:

Test Case 1: Nominal case - all components operating normally

Test Case 2: Single fuel turbopump out (when a fuel pump fails, the associated turbine is also shut down, and vice versa).

Test Case 3: Single oxidizer turbopump out (when a LOX pump fails, the associated turbine is also shut down, and vice versa).

Test Case 4: One fuel turbopump AND one oxidizer turbopump out.

Test Case 5: Two thrust chambers (with cooling jackets) out. It is assumed that if a single thrust chamber fails, the opposing chamber must be shut off to balance vehicle thrust. The same will be true in a cluster of discrete engines.

Test Case 6: A 5% flow leak in Fuel Pump Discharge Manifold (FPDM).

Test Case 7: A 5% flow leak in Heat Exchanger (cooling jacket) Discharge Manifold (HXDM).

Test Case 8: A 5% flow leak in Fuel Turbine Discharge Manifold (FTDM).

Test Case 9: A 5% flow leak in Oxidizer Turbine Discharge Manifold (OTDM).

Test Case 10: A 5% flow leak in Oxygen Pump Discharge Manifold (OPDM).

Each of the above scenarios was investigated at *High* and *Low* thrust levels. The High thrust level of 80000 lbf (10000 lbf per chamber) was selected to provide approximately 9% turbine bypass while operating as close as possible to the turbomachinery design conditions. The Low thrust level of 29600 lbf (3700 lbf per chamber) was determined as the nominal minimum thrust before the potential onset of stall in the second stage fuel pump (the first to stall). The stall point is defined here by the zero slope point on head vs. flow map for each pump. In this study, the turbine bypass valves are varied to maintain desired system thrust in spite of the component failures (*closed-loop control*). Failed components are isolated from the rest of the system using shut-off valves, located upstream and downstream of each component.

For each of the above listed failure cases, two indicators of system response are considered. The first indicator is the amount of bypass flow around each turbine cluster required to maintain the High thrust level. Decreased turbine bypass margins limit the ability of the system to provide higher-than-rated thrust excursions for emergency throttling and mission aborts. The

second indicator of system response is the pump stall margin, defined here as

$$\text{Stall Margin} = (\phi - \phi_{\text{stall}}) / \phi_{\text{stall}}$$

where  $\phi$  is the pump flow coefficient<sup>8</sup> for each scenario at the Low thrust level, and  $\phi_{\text{stall}}$  is the flow coefficient at which stall may occur in each pump. When the  $\phi$  is below  $\phi_{\text{stall}}$ , the operation of the pump may become unstable.

Tables 1a and 1b summarize key system performance parameters for the Nominal test case at High and Low thrusts respectively. Table 2 shows the changes from nominal in several parameters for the system's closed-loop response to the failure cases described above. These changes are expressed as percentages of the nominal values.

Figure 4 shows the main turbine bypass and fuel turbine bypass flows for each scenario at High thrust, depicted in a histogram format. Turbine bypass margin is not a limiting factor at Low thrust for these failure cases.

Figure 5 shows the second-stage fuel pump stall margins at Low thrust for each scenario. The second stage fuel pump is highlighted here because it stalls first in each case, and will therefore be the limiting factor. Pump stall is not a problem at High thrust for these failure cases.

Figures 6a, b, and c show the system operating points, plotted on the performance maps for the first stage fuel pump, the combined second and third stage fuel pumps, and the LOX pump respectively. The operating points for both High and Low thrust levels are shown, numbered according to test case. These figures graphically depict the changes in pump operation from nominal (Case 1) for the various failure scenarios.

## Discussion of Results

The first observation made during this study was that an FTBV is required as well as the MTBV, even for a healthy system, in order to maintain desired LOX injector pressure drops at lower thrusts. Adequate injector delta-P is necessary to ensure that thrust chamber pressure oscillations do not propagate back into the system. The injector delta-P also helps atomize the LOX for better mixing of propellants in the thrust chamber. In the nominal High thrust condition for the system, the FTBV is closed, but must be opened in order to throttle the system to points below 68000 lbf thrust. Both MTBV and

FTBV are required to accommodate component failures at all thrust levels. Even so, the combination of MTBV and FTBV used here is not always adequate to accommodate component failures, as is discussed below.

Consider the effects of component failures on system performance at the High thrust level (80000 lbf total system thrust). As shown in Figure 4, the failure of a single LOX turbopump will prevent the system from operating at full thrust, despite attempts to compensate using the turbine bypass control valves. With one LOX turbopump shut-off, the maximum system thrust will decrease to 62000 lbf. Note also that while the system cannot maintain 100% thrust with a single LOX turbopump out, it can accommodate the loss of a LOX turbopump in combination with the shut-down of a fuel turbopump. It may be advantageous, therefore, to pair the fuel and LOX turbopumps and remove the intervening FTDM ring manifold. This would, however, require separate fuel turbine bypass valves for each turbopump pair. Removing both turbopumps in this case also drives the remaining LOX turbopumps to dangerously high shaft speeds, as illustrated in Figure 6c (Case 4). Rotor-dynamic stability limitations may preclude the option of shutting down a turbopump pair and maintaining full-thrust in this configuration. An alternative solution to accommodate this type of fault is to redesign the system control strategy, using independent fuel turbine and LOX turbine bypass valves (instead of the MTBV and FTBV). Additional simulations have shown that independent turbine bypasses allow the system to maintain full thrust in the event of a LOX turbopump failure, without shutting down other components.

The shut-down of two thrust chambers is another case where the desired High thrust cannot be maintained by altering turbine bypass flows. Furthermore, when two thrust chambers are shut-off, it is not possible to attain even 75% of the desired system thrust (maintaining healthy chambers at their nominal high thrusts). In fact, the system cannot maintain the desired LOX injector delta-P for thrusts above 42000 lbf, and the pumps will be in danger of stalling for thrusts only slightly lower than 42000 lbf. Thus there is only a narrow range of thrusts around 53% where the system will maintain stable operation. The loss of two thrust chambers can be accommodated (at 75% system thrust) if a fuel and a LOX turbopump are also shut-off, but this negates the fault tolerance of the IME.

Figure 4 indicates that relatively small leaks in the distribution manifolds (5% of the inlet flow) can be accommodated at High thrust levels. Leaks in the FPDM or HXDM do, however, cause significant decreases in the turbine bypass margin. Furthermore, it has been found that a 10 % flow leak in either of these two manifolds cannot be accommodated at High thrust. In addition to performance degradation, leaks in the manifolds will produce serious safety concerns. The manifolds in the IME configuration are not redundant and therefore represent a potential single-point failure mode for the system.<sup>1</sup>

As mentioned previously, the potential onset of pump stall has been used to define the Low thrust level (29600 lbf total system thrust). This study therefore assumes a nominal stall margin of only about 1 % to begin with. As seen in Figure 5, most of the component failure cases actually drive the fuel pumps away from stall. This is true because these failures increase the flow rates through the operating fuel pumps without a proportionate rise in required discharge pressures. The failure of a single LOX turbopump or a leak in the OPDM will cause a small decrease in the fuel pump stall margin, since these failures increase the load on the fuel pumps without increasing the fuel pump flows. By far the most severe problem with stall comes from the shut-down of two thrust chambers, which decreases the flows in all pumps while requiring them to keep the same discharge pressures. This condition drives all pumps into the stall region at Low thrust. For thrust chamber failure, the nominal stall margin can be maintained at the Low thrust level if a pair of fuel and LOX turbopumps are shut-off as well.

These results suggest that an IME propulsion system based on a full-expander cycle may have limited fault-tolerant capabilities. It may not be possible to accommodate the loss of a turbopump or thrust chamber by altering the operation of the remaining components. This study has indicated that the magnitude of change required to accommodate component failures may well be beyond the capacity of the remaining components, or may lead to stall or rotor-dynamic instabilities. Although system designs based on an expander cycle are simple and involve temperatures and pressures which place less strain on components, a more powerful cycle, using gas generators for example, may be more fault tolerant. It may also be possible to improve the system fault tolerance by using a larger number of redundant components; the loss of a given component will place less of a load on the surviving components (see also Ref.1). Alternative configurations such as these should be examined using system models as well.

## Summary and Concluding Remarks

A computer model has been created using the ROCETS code in order to study the steady-state performance of an IME rocket propulsion system. The IME configuration chosen for this study is a full-expander cycle comprised of eight thrust chambers, four fuel turbopumps and four LOX turbopumps. Using the model, the effects of several failure scenarios on system performance have been examined. Given the present designs of the turbomachinery and other components, several limitations have been noted regarding the IME system fault tolerance. In the IME system modeled here, failure of a LOX turbopump or thrust chamber cannot be accommodated at full-thrust. The impacts of these failures on system performance can be mitigated by shutting down other, unfailed system components. Removing healthy components to accommodate failures, however, negates the potential advantages in fault-tolerance for the IME over discrete engines. The model indicates that this IME system can accommodate small leaks (5% of flow) in the distribution manifolds. With the exception of a thrust chamber failure, the scenarios simulated here do not appear to significantly increase the threat of stall at low thrust levels; in most cases, the failures actually reduce the likelihood of stall. No attempt has been made here to assess the threat of pump cavitation.

This simulation study has provided some important information regarding the failure response of one IME configuration. Although this study has indicated that the IME may not be as fault-tolerant as previously believed, it would be premature to suggest that the IME concept is unworkable based on these results alone. It may yet be possible to redesign the components or system to improve fault tolerance; these simulation results can, in fact, be used to guide such design efforts. This study also highlights the utility of system modeling for conceptual design of space propulsion systems.

## Acknowledgements

The authors would like to thank Dean Scheer (Sverdrup Technology) and Joseph P. Veres (NASA) for their assistance in this paper. Mr. Scheer designed the IME thrust chamber geometry, and Mr. Veres designed several of the IME pumps and turbines. Other component models were provided by the Pratt & Whitney Government Engines and Space Propulsion division for use in the AETB program under contract NAS3-25960.

## References

1. Hardy, T. and Rapp, D., *Reliability Studies of Integrated Modular Engine System Designs*, AIAA Paper 93-1886, June 1993.
2. Pratt & Whitney Government Engines Business, *System Design Specification for the ROCETS System - Final Report*, NASA CR-184099, July 1990.
3. Parsley, R.C. and Ward, T.B., *Integrated Modular Engine: Reliability Assessment*, AIAA Paper 92-3695, July 1992.
4. Pratt & Whitney Government Engines & Space Propulsion, *Advanced Expander Test Bed Program - Preliminary Design Review Report*, NASA CR-187081, May 1991.
5. Veres, J.P. , *PUMPA - Pump Meanline Flow Code*, no formal report, contact author at NASA Lewis Research Center, Cleveland Ohio.
6. Veres, J.P. , *TURBA - Turbine Meanline Flow Code*, no formal report, contact author at NASA Lewis Research Center, Cleveland Ohio.
7. Frankenfield, B. and Carek, J., *Fluid System Design Studies of an Integrated Modular Engine System* , AIAA Paper 93-1887, June 1993.
8. Shepperd, D.G., *Principles of Turbomachinery*, Macmillan Company 1956.
9. Bartz, D.R., *A Simplified Equation for Rapid Estimation of Rocket Nozzle Convective Heat Transfer Coefficients*, Jet Propulsion Vol.27, pp.29-51, 1957.
10. Holman, J.P., *Heat Transfer - Fourth Edition* McGraw Hill, 1976.







Table 2 : IME Closed-loop Failure Response at Hight Thrust

HIGH THRUST OPERATION (90000 lbf total for system)												
	Nominal Value of Param	Changes from Nominal Values due to Fault										
		1 Fuel TP out	1 LOX TP out	1 FTP and 1 OTP out	2 Thrust Chambers out	5% Fuel Pump Disch Manif leak	5% Cooling Disch Manif leak	5% Fuel Disch Manif leak	5% LOX Turb Disch Manif leak	5% LOX Turb Disch Manif leak	5% LOX Pump Disch Manif leak	
Fuel Pump Discharge Pressure	3118	16.10%	-	32.04%	-	3.81%	5.43%	2.92%	5.16%	0.64%		
LOX Pump Discharge Pressure	1621	0.00%	-	86.27%	-	14.77%	18.24%	0.00%	17.21%	0.00%		
Fuel Pump Shaft 1 Speed	82024	14.74%	-	20.53%	-	2.84%	3.54%	2.41%	3.35%	0.24%		
Fuel Pump Shaft 2 Speed	81975	16.29%	-	20.57%	-	2.58%	3.17%	2.13%	3.02%	0.28%		
LOX Pump Shaft Speed	40059	0.01%	-	36.37%	-	5.17%	6.34%	0.01%	6.00%	1.75%		
Cooling Jacket Discharge Temperature	629.4	1.84%	-	2.83%	-	0.33%	-3.29%	-3.19%	-3.10%	0.05%		
MTBV Flow Rate	1.939	0.21%	-	-48.27%	-	-56.93%	-97.25%	-22.02%	-31.87%	-19.65%		
FTBV Flow Rate * Note 1	0.00%	79.99%	*Note 2	0.00%	*Note 2	0.00%	0.00%	13.55%	0.00%	12.89%		
LOW THRUST OPERATION (29600 lbf total for system)												
	Nominal Value of Param	Changes from Nominal Values due to Fault										
		1 Fuel TP out	1 LOX TP out	1 FTP and 1 OTP out	2 Thrust Chambers out	5% Fuel Pump Disch Manif leak	5% Cooling Disch Manif leak	5% Fuel Disch Manif leak	5% LOX Turb Disch Manif leak	5% LOX Turb Disch Manif leak	5% LOX Pump Disch Manif leak	
Fuel Pump Discharge Pressure	892.20	6.74%	2.28%	8.89%	29.23%	1.00%	1.63%	0.96%	1.21%	0.29%		
LOX Pump Discharge Pressure	543.90	0.00%	0.00%	0.00%	27.91%	0.00%	0.00%	0.00%	0.00%	0.00%		
Fuel Pump Shaft 1 Speed	40804.00	7.86%	1.38%	8.78%	13.22%	0.99%	1.61%	0.88%	1.13%	0.18%		
Fuel Pump Shaft 2 Speed	40213.00	5.36%	0.99%	6.35%	16.19%	0.78%	0.84%	0.52%	0.65%	0.12%		
LOX Pump Shaft Speed	20211.00	0.00%	6.33%	6.33%	12.62%	0.00%	0.00%	0.00%	0.00%	0.00%		
Cooling Jacket Discharge Temperature	698.30	0.01%	0.01%	0.10%	-3.71%	0.01%	-3.98%	-2.23%	-2.84%	-0.03%		
MTBV Flow Rate	2.40	-0.08%	51.19%	51.15%	-69.12%	-0.21%	-7.09%	-4.29%	8.21%	-2.75%		
FTBV Flow Rate	1.50	40.01%	-88.84%	-46.88%	10.79%	-8.19%	-5.39%	14.18%	-3.46%	3.46%		
			*Note 3		*Note 3							

Note 1 - Because FTBV is closed in Nominal Case, a direct comparison cannot be made for the fault cases where FTBV is open. Instead, FTBV flow is compared to the MTBV flow of the Nominal Case to obtain a percent value.

Note 2 - The system cannot achieve the desired thrust per chamber because there is insufficient turbine flow to provide power.



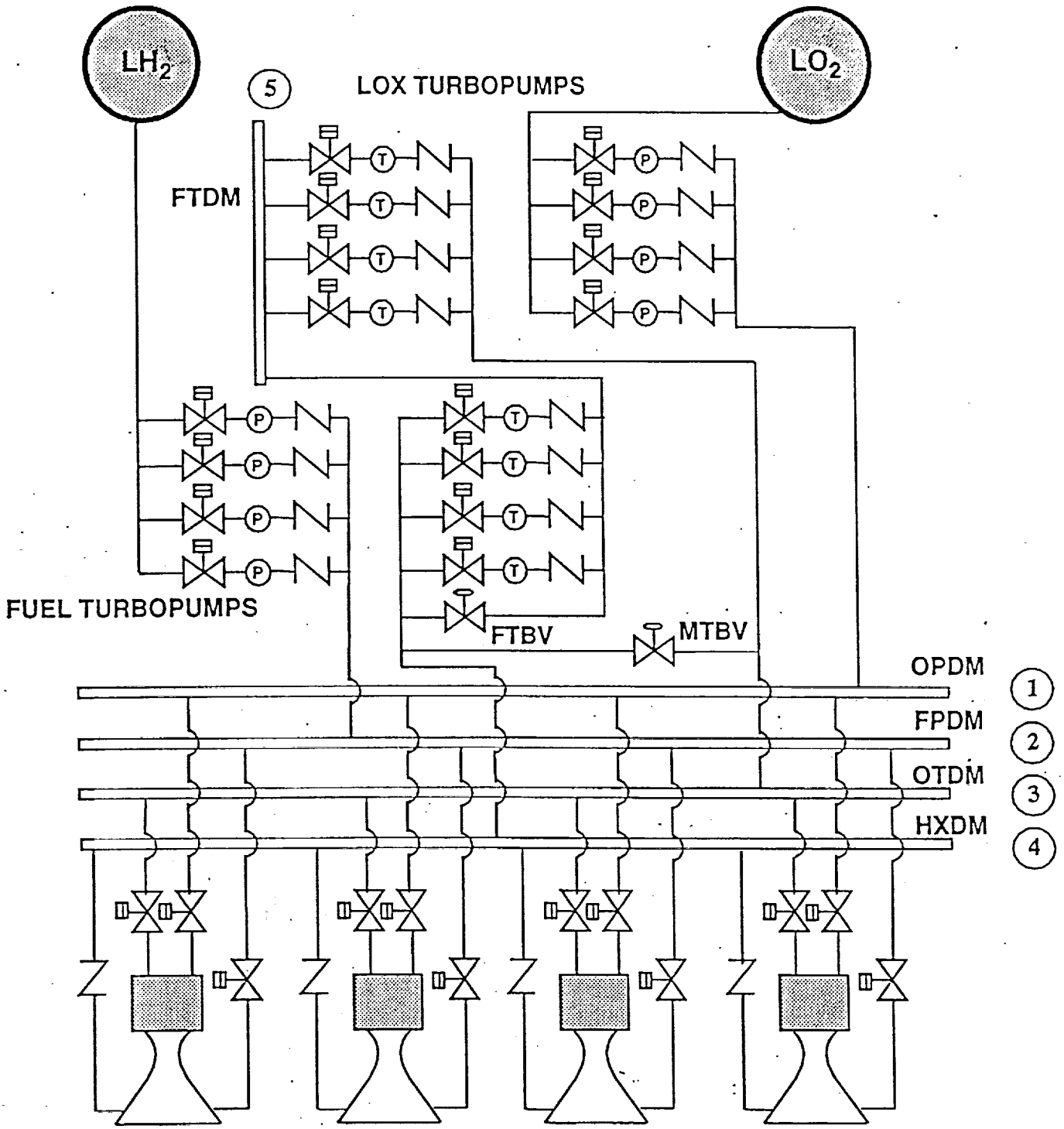

Note 3 - The second stage fuel pump is operating at a point where stall is likely to occur.

FIGURE 1: INTEGRATED MODULAR ENGINE (IME) SCHEMATIC DIAGRAM

EXPANDER CYCLE CONFIGURATION



8 THRUST CHAMBER ASSEMBLIES TOTAL

-  CONTROL VALVE
-  SHUT-OFF VALVE
-  CHECK VALVE
-  PUMP
-  TURBINE

MANIFOLDS

- ① OX PUMP DISCHARGE (OPDM)
- ② FUEL PUMP DISCHARGE (FPDM)
- ③ OX TURBINE DISCHARGE (OTDM)
- ④ COOLING DISCHARGE (HXDM)
- ⑤ FUEL TURBINE DISCHARGE (FTDM)

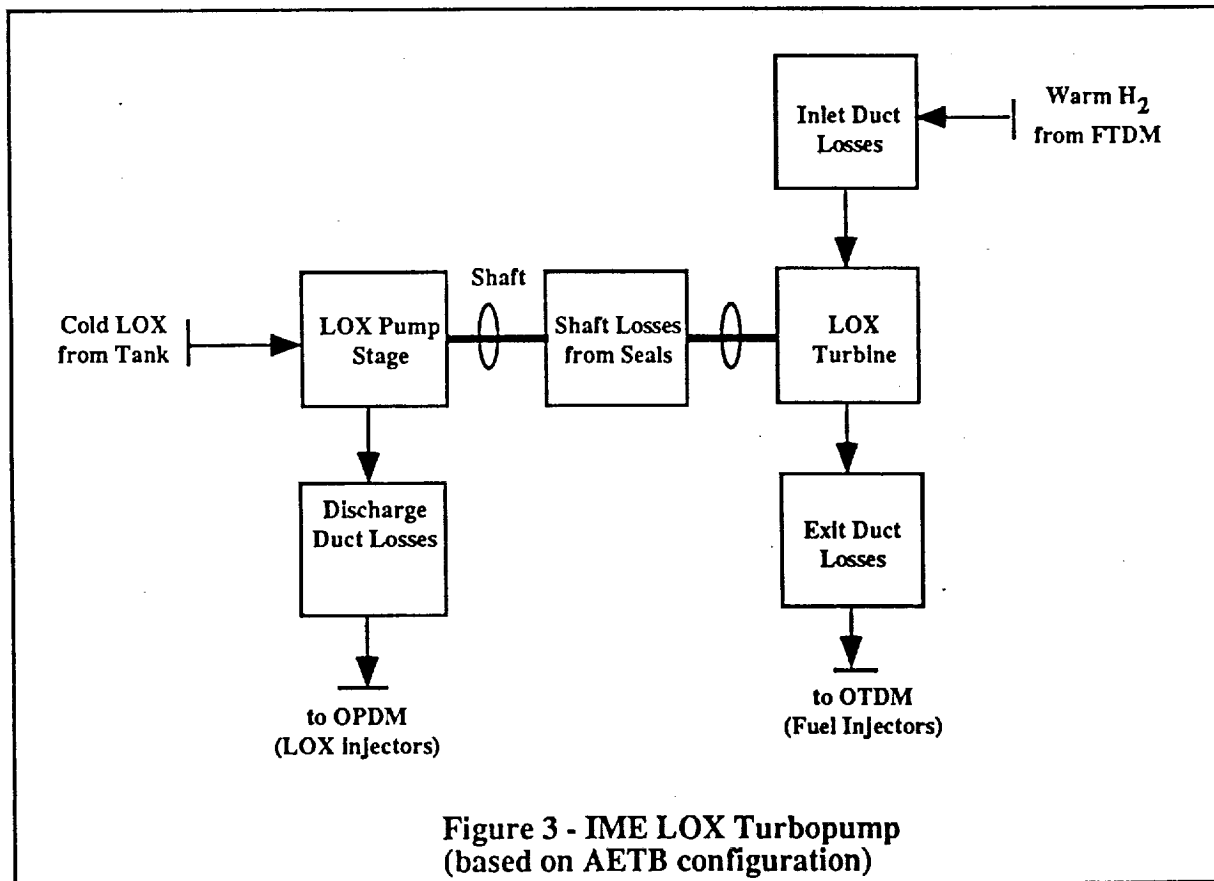
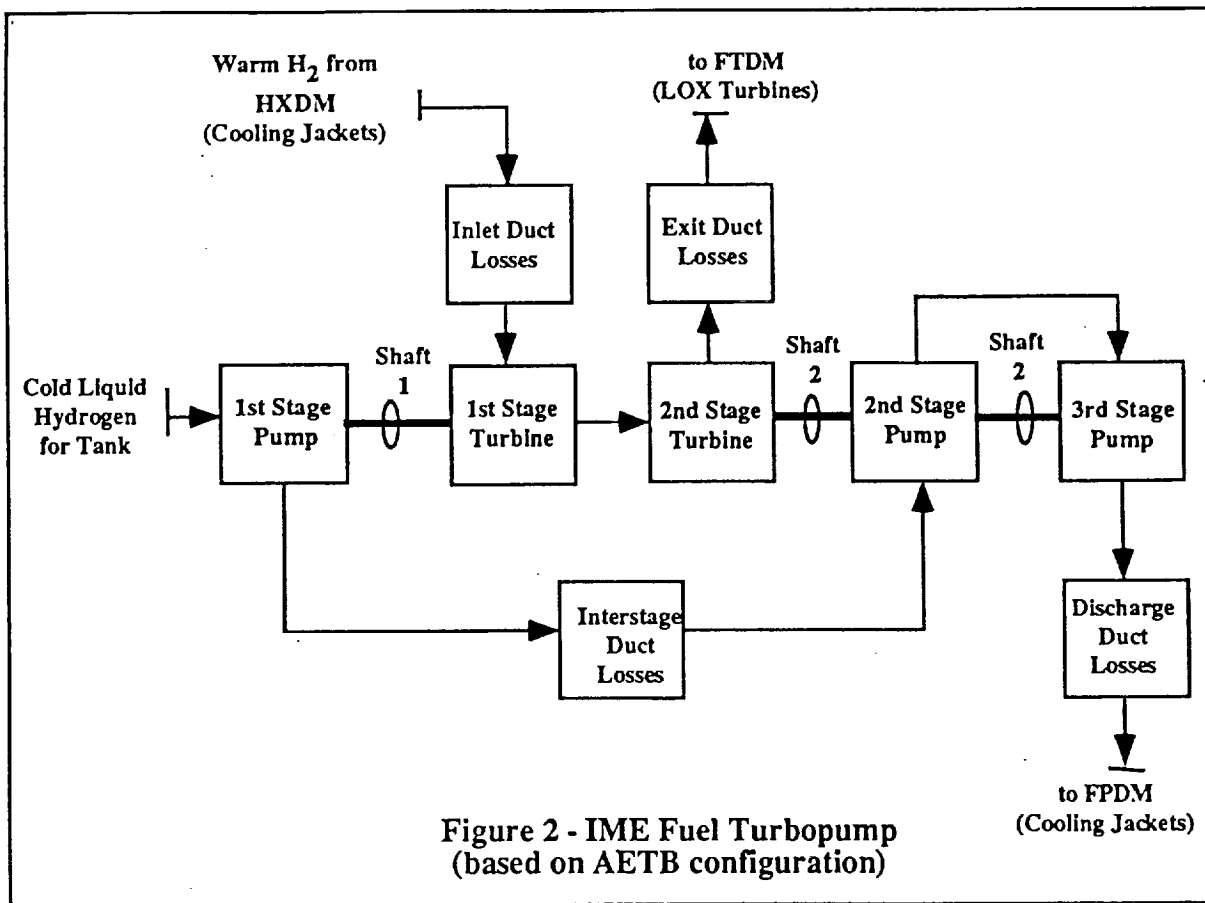

Figure 4: Closed-loop Turbine Bypass Flow Response to Faults at High Thrust

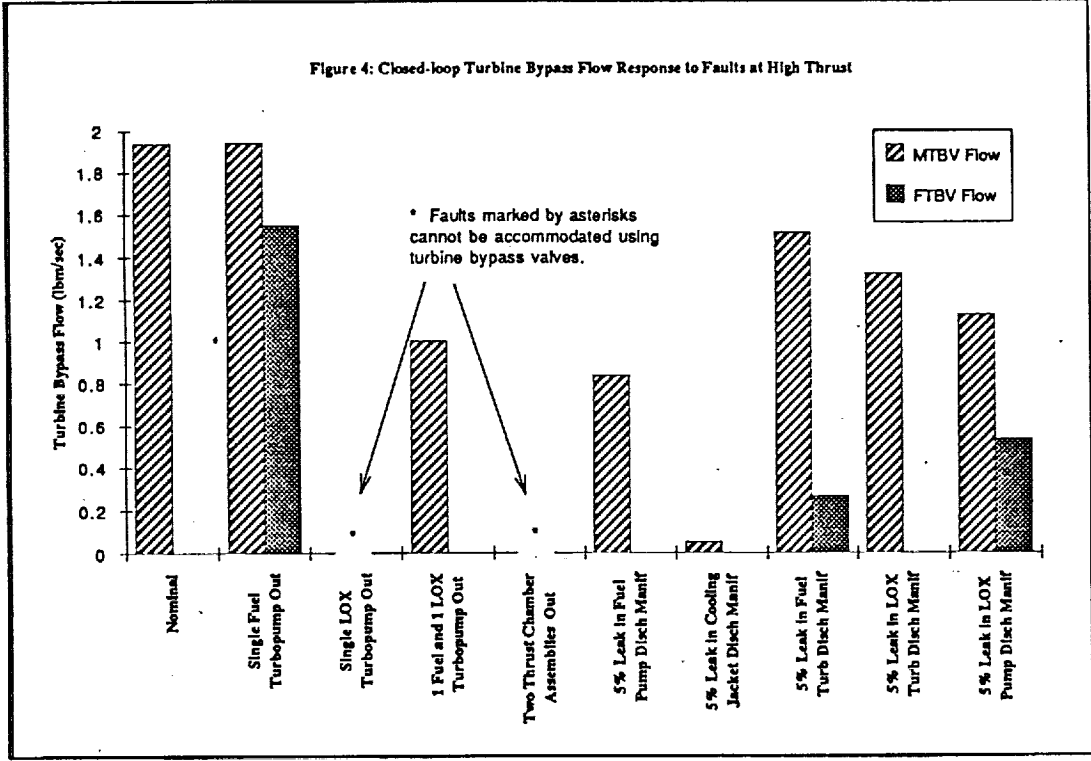

Figure 5: FUEL PUMP 2nd STAGE STALL MARGIN at LOW THRUST (Closed Loop)

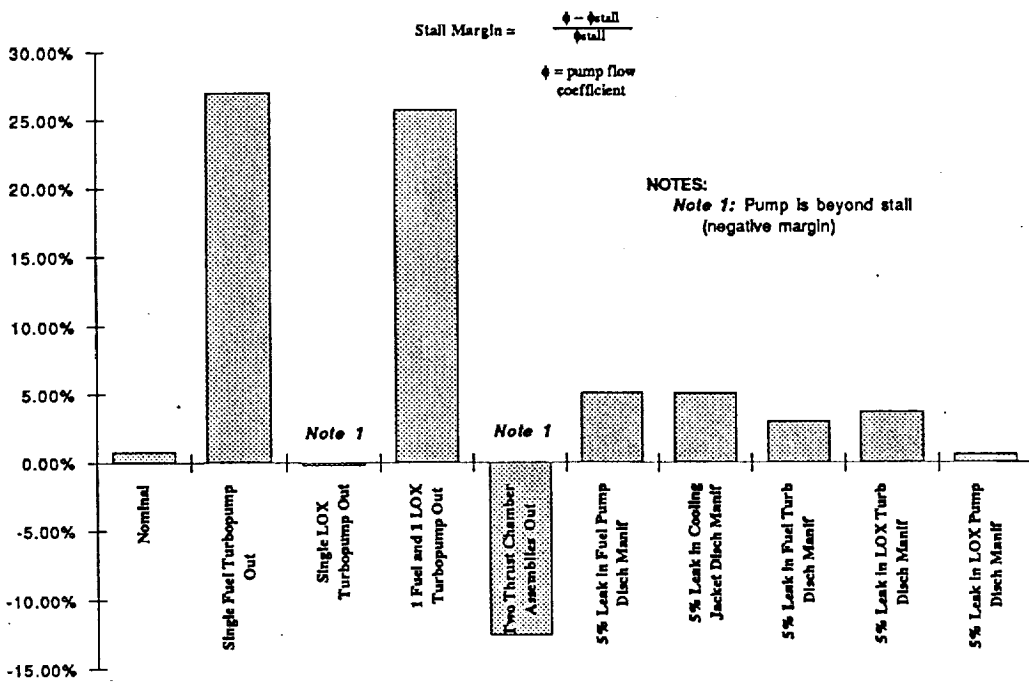
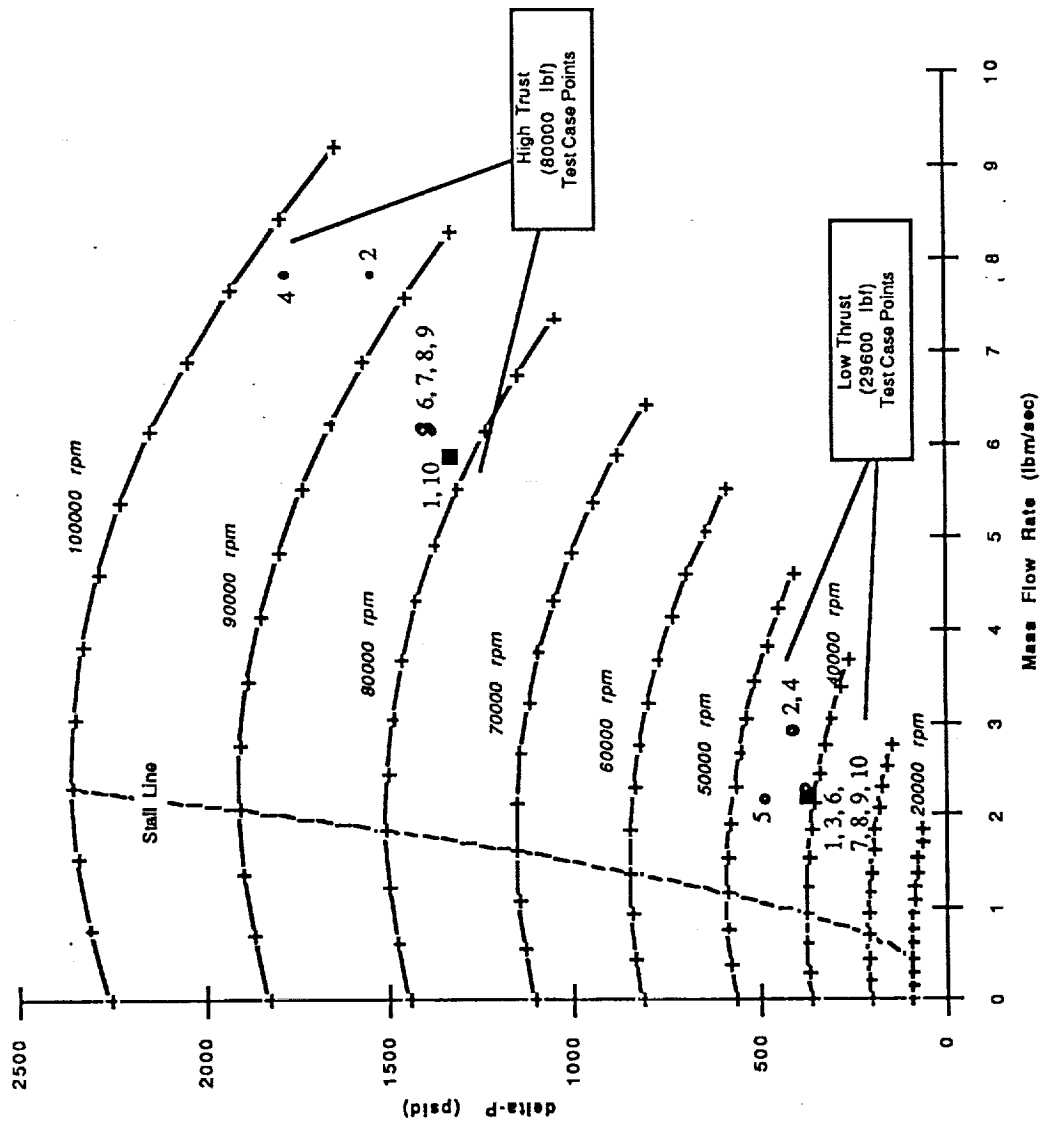

Figure 6a - 1st Stage Fuel Pump Map



Key to Symbol Labels

- Case 1 ■ Nominal Case (no failures)
- Case 2 ● Single Fuel TP out
- Case 3 ○ Single LOX TP out
- Case 4 ○ One Fuel and One LOX TP out
- Case 5 ○ Two Thrust Chambers out
- Case 6 ○ 5% Leak in FPDM
- Case 7 ○ 5% Leak in HXDM
- Case 8 ○ 5% Leak in FTDM
- Case 9 ○ 5% Leak in OTDM
- Case 10 ○ 5% Leak in OPDM



Figure 6b - Combined 2nd / 3rd Fuel Pump Map

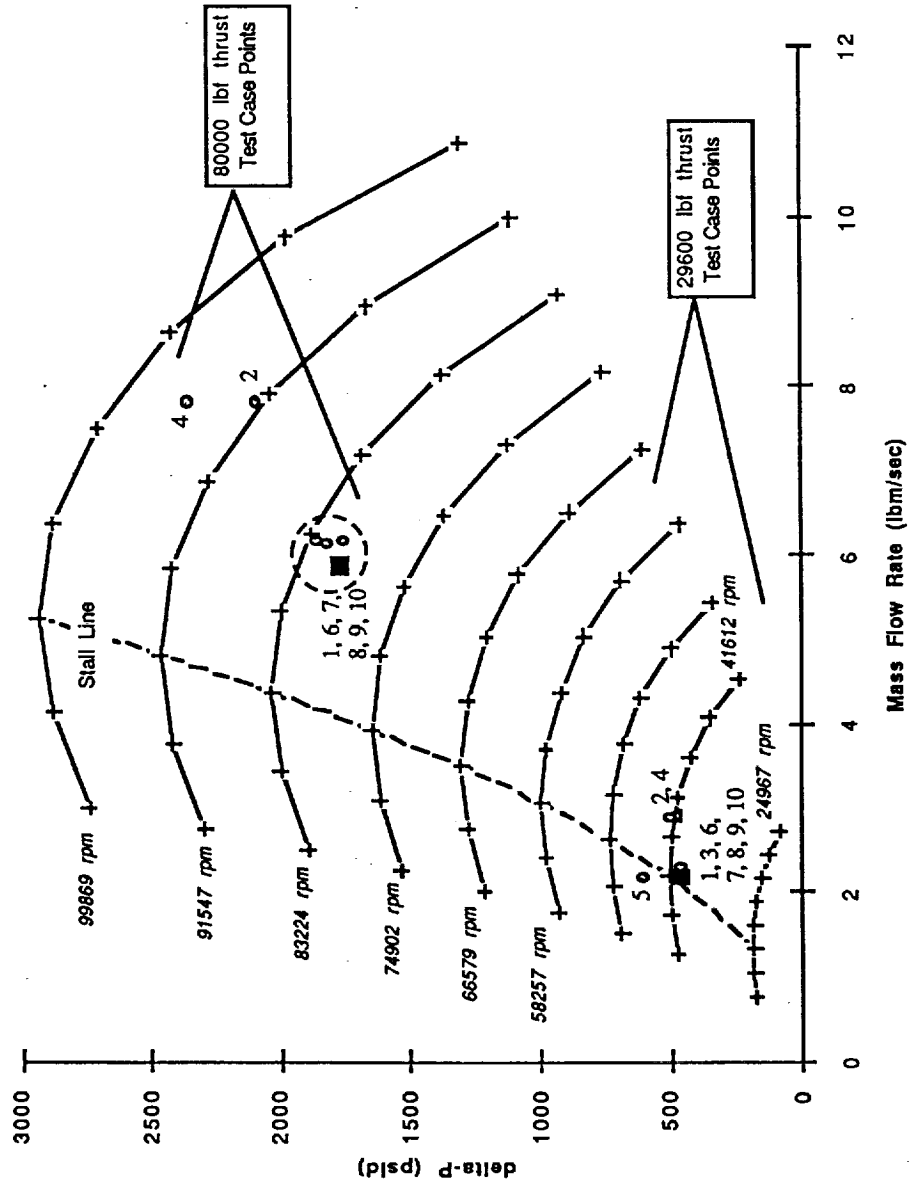

Key to Symbol Labels

Case 1	Nominal Case (no failures)
Case 2	Single Fuel TP out
Case 3	Single LOX TP out
Case 4	One Fuel and One LOX TP out
Case 5	Two Thrust Chambers out
Case 6	5% Leak in FPDM
Case 7	5% Leak in HXDM
Case 8	5% Leak in FTDM
Case 9	5% Leak in OTDM
Case 10	5% Leak in OPDM

Figure 6c - LOX Pump Map

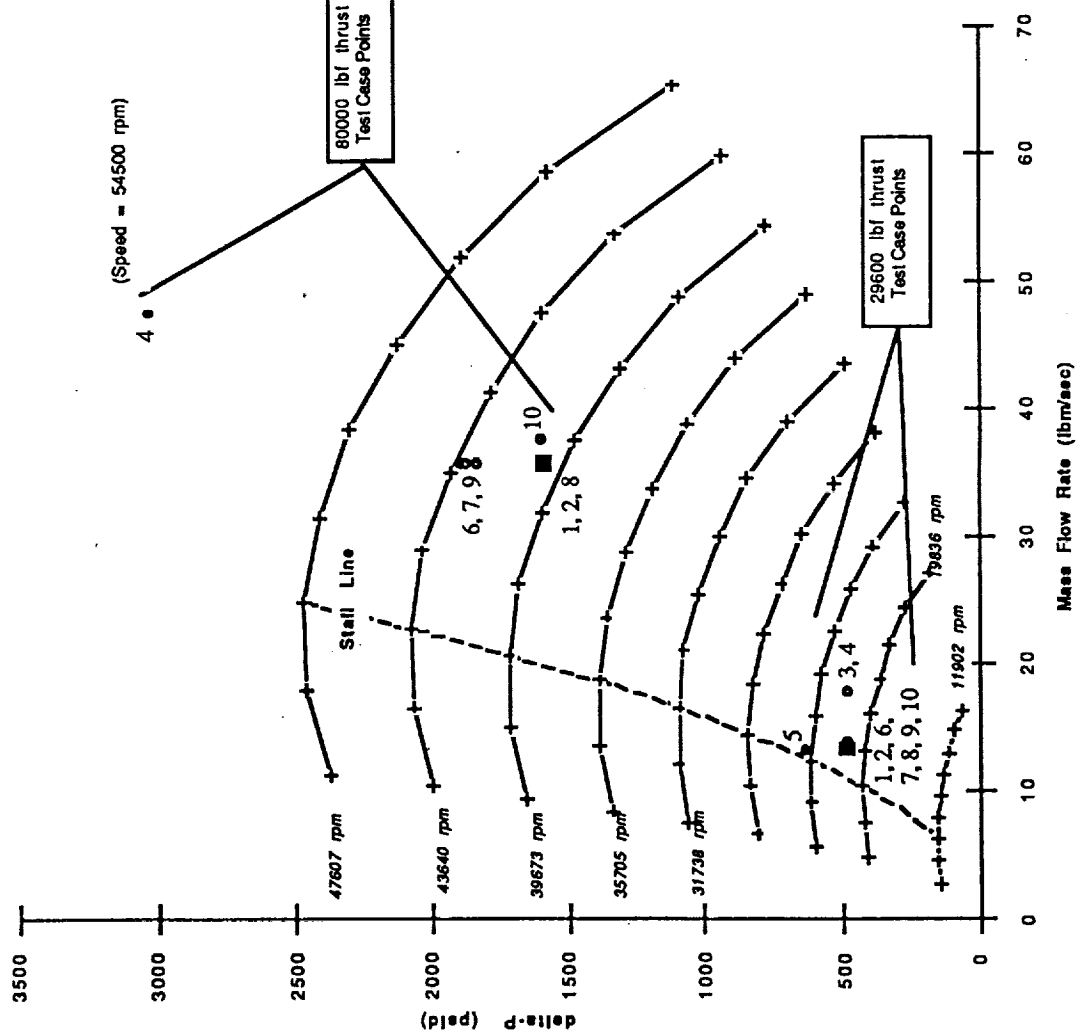

**Key to Symbol Labels**

- Case 1 Nominal Case (no failures)
- Case 2 Single Fuel TP out
- Case 3 Single LOX TP out
- Case 4 One Fuel and One LOX TP out
- Case 5 Two Thrust Chambers out
- Case 6 5% Leak in FPDM
- Case 7 5% Leak in HXDM
- Case 8 5% Leak in FTDM
- Case 9 5% Leak in OTDM
- Case 10 5% Leak in OPDM



# REPORT DOCUMENTATION PAGE

Form Approved  
OMB No. 0704-0188

Public reporting burden for this collection of information is estimated to average 1 hour per response, including the time for reviewing instructions, searching existing data sources, gathering and maintaining the data needed, and completing and reviewing the collection of information. Send comments regarding this burden estimate or any other aspect of this collection of information, including suggestions for reducing this burden, to Washington Headquarters Services, Directorate for Information Operations and Reports, 1215 Jefferson Davis Highway, Suite 1204, Arlington, VA 22202-4302, and to the Office of Management and Budget, Paperwork Reduction Project (0704-0188), Washington, DC 20503.

1. AGENCY USE ONLY (Leave blank)	2. REPORT DATE July 1993	3. REPORT TYPE AND DATES COVERED Final Contractor Report	
4. TITLE AND SUBTITLE  Predicted Performance of an Integrated Modular Engine System		5. FUNDING NUMBERS  WU-584-04-11 C-NAS3-25266	
6. AUTHOR(S)  Michael Binder and James L. Felder		8. PERFORMING ORGANIZATION REPORT NUMBER  E-9586	
7. PERFORMING ORGANIZATION NAME(S) AND ADDRESS(ES)  Sverdrup Technology, Inc. Lewis Research Center Group 2001 Aerospace Parkway Brook Park, Ohio 44142		10. SPONSORING/MONITORING AGENCY REPORT NUMBER  NASA CR-190787	
9. SPONSORING/MONITORING AGENCY NAME(S) AND ADDRESS(ES)  National Aeronautics and Space Administration Lewis Research Center Cleveland, Ohio 44135-3191		11. SUPPLEMENTARY NOTES  Project Manager, Frank D. Berkopec, Propulsion Technology Division, NASA Lewis Research Center, organization code 5300, (216) 977-7562.	
12a. DISTRIBUTION/AVAILABILITY STATEMENT  Unclassified - Unlimited Subject Category 20  This publication is available from the NASA Center for Aerospace Information, (301) 621-0390.		12b. DISTRIBUTION CODE	
13. ABSTRACT (Maximum 200 words)  Space vehicle propulsion systems are traditionally comprised of a cluster of discrete engines, each with its own set of turbopumps, valves, and a thrust chamber. The Integrated Modular Engine (IME) concept proposes a vehicle propulsion system comprised of multiple turbopumps, valves, and thrust chambers which are all interconnected. The IME concept has potential advantages in fault-tolerance, weight, and operational efficiency compared with the traditional clustered engine configuration. The purpose of this study is to examine the steady-state performance of an IME system with various components removed to simulate fault conditions. An IME configuration for a hydrogen/oxygen expander cycle propulsion system with four sets of turbopumps and eight thrust chambers has been modeled using the ROCKET Engine Transient Simulator (ROCETS) program. The nominal steady-state performance is simulated, as well as turbopump, thrust chamber and duct failures. The impact of component failures on system performance is discussed in the context of the system's fault tolerant capabilities.			
14. SUBJECT TERMS  Spacecraft power; Spacecraft propulsion		15. NUMBER OF PAGES 18	
		16. PRICE CODE A03	
17. SECURITY CLASSIFICATION OF REPORT Unclassified	18. SECURITY CLASSIFICATION OF THIS PAGE Unclassified	19. SECURITY CLASSIFICATION OF ABSTRACT Unclassified	20. LIMITATION OF ABSTRACT

**National Aeronautics and  
Space Administration**

**Lewis Research Center  
21000 Brookpark Rd.  
Cleveland, OH 44135-3191**

**Official Business  
Penalty for Private Use \$300**

**POSTMASTER: If Undeliverable — Do Not Return**

