



**Vaccum Gas Tungsten Arc Welding  
Phase I Report**

**Contract Number NAS8-39932**

**Period of Performance  
October 1993 to March 1995**

**Prepared for:**

**C.S Jones III, Program Monitor (EH25)**

**National Aeronautics and Space Administration  
George C. Marshall Space Flight Center  
Marshall Space Flight Center, Alabama 35812**

**Prepared By:**

**J.L. Weeks, P. D. Krotz, D. T. Todd & Y. K. Liaw**

**Rocketdyne Division  
Rockwell International  
6633 Canoga Ave  
Canoga Park, CA 91304**

# TABLE OF CONTENTS

	<u>Page</u>
TABLE OF CONTENTS	2
LIST OF ILLUSTRATIONS	3-4
EXECUTIVE SUMMARY	5
INTRODUCTION	6
PHASE 1 - TECHNOLOGY VALIDATION	7
• Facility Modification - Task 1100	7
• Materials Selection - Task 12000	9
• VGTA Weld Experiments & Downselection - Task 1300	9
• Experimental Procedure	9
• NARloy-Z	10
• Inconel 903 Overlays	11
• Inconel 718	12
• High-Frequency, Pulsed-Current & Air-Coupled Acoustic GTAW - Task 13100	12
• Material Downselection	15
CONCLUSIONS & RECOMMENDATIONS	15

# LIST OF ILLUSTRATIONS

<b>Figure</b>	<b>Title</b>
1	Overall Program Schedule
2	Conventional and Vacuum GTAW Torches
3	Improved Vacuum Gas Tungsten Arc Welding Torch
4	Schematic of Original VGTAW System Used for Process Demonstration at NASA-MSFC
5	Schematic of Modified VGTAW System
6	Knoop Hardness Measurements on Shallow and Full Penetration Conventional and Vacuum GTA Welds on NARloy-Z
7	Photomicrographs of Shallow and Full Penetration Conventional GTA Welds on NARloy-Z
8	Photomicrographs of Shallow and Full Penetration Vacuum GTA Welds on NARloy-Z
9	Photomicrographs of Incoloy 903 VGTAW Overlays on Inconel 718 at 25x and 100x
10	Microstructure of Vacuum Gas Tungsten Arc Welding for Cast Inconel 718 Weldability Test
11	Microstructure of Gas Tungsten Arc Welding for Cast Inconel 718 Weldability Test
12	Macro & Microstructure of Gas Tungsten Arc Welding for Aluminum Lithium Weldability Test
13	Schematic of Air Coupled Acoustic Experimental Weld Set-up
14	Microstructure of Gas Tungsten Arc Welding for Aluminum Lithium Weldability Test - Air Coupled Acoustic, 100 Hz
15	Microstructure of Gas Tungsten Arc Welding for Aluminum Lithium Weldability Test - Air Coupled Acoustic, 203 Hz

## LIST OF ILLUSTRATIONS, cont'd

<u>Figure</u>	<u>Title</u>
16	Microstructure of Vacuum Gas Tungsten Arc Welding for Aluminum Lithium Weldability Test
17	Microstructure of Vacuum Gas Tungsten Arc Welding for Aluminum Lithium Weldability Test
18	Comparison of Knoop Hardness for Conventional GTAW, VGTAW and Acoustic GTAW

# Vacuum Gas Tungsten Arc Welding Phase I Report

## Executive Summary

The Rocketdyne Division of Rockwell International is conducting a program for the National Aeronautics and Space Administration - Marshall Space Flight Center entitled "Vacuum Gas Tungsten Arc Welding". This two phase program is being performed under NASA Contract NAS8-39932 as part of the NASA Research Announcement, NRA-92-MSFC-1 and all technical work is being conducted at the MSFC. The work performed during Phase I of this program is presented herein.

This two year program will investigate Vacuum Gas Tungsten Arc Welding (VGTAW) as a method to modify or improve the weldability of normally difficult-to-weld materials. VGTAW appears to offer a significant improvement in weldability because of the clean environment and lower heat input needed. The overall objective of the program is to develop the VGTAW technology and implement it into a manufacturing environment that will result in lower cost, better quality and higher reliability aerospace components for the space shuttle and other NASA space systems.

Phase I of this program was aimed at demonstrating the process's ability to weld normally difficult-to-weld materials. Phase II will focus on further evaluation, a hardware demonstration and a plan to implement VGTAW technology into a manufacturing environment.

During Phase I, the following tasks were performed:

- Task 11000 Facility Modification. An existing vacuum chamber was modified and adapted to a GTAW power supply.
- Task 12000 Materials Selection. Four difficult-to-weld materials typically used in the construction of aerospace hardware were chosen for study.
- Task 13000 VGATW Experiments. Welding experiments were conducted under vacuum using the hollow tungsten electrode and evaluated. As a result of this effort, two materials, NARloy Z and Incoloy 903, were downselected for further characterization in Phase II.
- Task 13100 Aluminum-Lithium Weld Studies. This task was added to the original work statement to investigate the effects of vacuum welding and weld pool vibration on aluminum-lithium alloys. It was completed as part of Phase I.

During Phase II, the following tasks are planned:

- Task 21000 Materials Characterization. The materials downselected in Phase I will be characterized.
- Task 22000 Hardware Demonstration. A representative hardware specimen will be fabricated and evaluated.
- Task 23000 Technology Implementation Plan. A plan will be prepared for implementing this technology.

An overall schedule showing the time phasing for this program is presented in Figure 1.

The work performed in Phase I is presented below.

## Introduction

The design of aerospace hardware for propulsion systems and launch vehicles has been driven by performance and life, as illustrated by the Space Shuttle Main Engine (SSME). Typically, welded construction is utilized to join metallic components to minimize weight and produce leak-free joints; however, the materials of construction for such components have tended to be selected primarily based on their physical or mechanical properties or their chemical compatibility, e.g., hydrogen embrittlement resistance, and to a lesser degree on their fabricability. As a result, these materials frequently may not be robust to welding. For example, Incoloy 903, which is used extensively on SSME, is weldable but may develop undesirable microfissures. This class of material can be categorized as difficult-to-weld.

Rocketdyne is well aware of the difficulties involved in welding these types of materials and has been working for several years to improve the weldability of such materials. One of the potential solutions to solving some of these welding problems is to produce gas tungsten arc (GTA) welds in a vacuum environment. The vacuum environment provides an extremely clean atmosphere which minimizes contamination that may be present in conventional GTA welding. It has also been demonstrated that lower power is required when GTA welds are produced in a vacuum as opposed to under an inert environment. The ability to produce GTA welds in a vacuum had not been possible until the development of the hollow tungsten electrode. The principal difference between this and the normal solid tungsten electrode is that the gas flows down the center of the electrode instead of around the outside. This enables a stable arc to be maintained under vacuum. Schematics of conventional and hollow electrode vacuum GTA welding torches are shown in Figure 2.

Rocketdyne has been developing the modified GTAW process since 1986 for use in space as a repair or assembly tool. Based on extensive experience with conventional GTAW in the fabrication of the SSME, it was felt that modifications

could be made to stabilize the arc in vacuum. This was achieved by introducing a hole into the center of the nonconsumable tungsten electrode, and then, supplying inert gas through this hole. This modification proved successful in providing a stable arc under vacuum and led to the first GTA welds produced in a vacuum. Further, it was found that for a given welding current and electrode-to-work distance, the weld produced is both deeper and wider than that produced by conventional GTAW, indicating that process efficiency is increased. Continued development work demonstrated improved weld bead contour, increased penetration, and reduced energy input and inert gas consumption.

Complementary efforts by Rocketdyne and the NASA-MSFC produced system modifications that led to improvements in the torch design. The improvement was in the method of delivering gas onto the the weld pool which resulted in better arc stability and reduced electrode erosion. A schematic of the improved VGTAW torch, which was patented (NASA Case# MSF-29766-1), is shown in Figure 3.

## **Phase I. Technology Validation**

The objective of this study is to evaluate the VGTAW process on a variety of difficult-to-weld materials. The study is investigating the effects of welding under a vacuum compared to welding under an inert environment. This information will be used to determine if the VGTAW process is a practical choice for implementation to solve existing welding problems. All welding experiments and evaluations are being conducted at the NASA-MSFC Productivity Enhancement Center.

### **Task II000. Facility Modification**

The objective of this task was to set-up a facility for conducting the VGTAW experiments. The vacuum system (See Figure 4) used for process demonstration at the MSFC required modifications since it had been set-up originally to study vapor deposited coatings. The following modifications were performed prior to initiating the VGTAW experiments:

- Designed and fabricated a new gas management system which consisted of a digital mass flow meter, precision low flow rotometer and a precision needle valve. The gas management system allows the introduction of gas into the vacuum environment through the hollow electrode. Precise control of the gas flow is critical to sustained operation and repeatability of the process. The VGTAW process uses a variety of gases (i.e., He, Ar, H<sub>2</sub>) to sustain the ionizing arc in different applications. For this reason, precision needle valves were placed in the feed lines from each of the gas supplies. These valves serve to minimize the effect of the course adjustment of the standard gas flow regulator. A digital mass flow meter was incorporated as a method of improving the repeatability of the gas flow rates. This system can measure and display gas flows from 1 to 350 ccm. In addition, the

precision, low-flow rotometer allows the gas to be regulated downstream of the mass flow meter and further reduces the effects of the course adjustment of a standard welding gas regulator. The precision needle valve located downstream of the rotometer is the last component of this design. It is located just above the port that feeds the gas through the hollow electrode. This mechanical device with regulated pressure and flow, provides a set orifice and does not react to the vacuum pressure. The system allows a specific gas flow and pressure to be fed through the port in the hollow electrode into the vacuum chamber. The gas management system is shown in relation to the modified VGTAW system in Figure 5.

- Modified and integrated a programmable three axes positioning device to manipulate the parts during welding. The requirement to operate the part manipulation device from outside the vacuum chamber without affecting the vacuum level prompted the following modifications:
  - Designed and fabricated a vacuum port that would allow the 64 pin low voltage connectors to pass through the vacuum chamber wall
  - Modified the software and hardware package supplied with the motion device system
  - Designed and fabricated an electrical and thermal isolation system for the motion device

The part handling system has three axes (X, Y & Z) of motion and is programmable from a remote console. This system allows the operator to change motion control programs and reprogram part paths in process without effecting the vacuum level.

- Designed and fabricated a new welding torch and chamber feedthrough. The welding torch used for the initial demonstration of VGTAW had several inherent problems. The inability to electrically insulate the torch body and leads inside the vacuum chamber due to the lack of a high temperature, vacuum compatible material proved to be a significant problem. During arc initiation, random arcing would occur due to the high frequency arc starting system. This was a consequence of the electrically insulated components becoming conductive due to metal vapor deposits on their surfaces.

The new welding torch feedthrough design isolated the welding torch body and all associated hardware into a one atmosphere environment. The design permits the hollow electrode to protrude into the work area of the vacuum environment and eliminates all random arcing potential from the welding torch body and leads. The new feedthrough also eliminated problems associated with coolant lines rupturing inside the vacuum chamber and contaminating the chamber and pumping system.

A schematic of the entire, modified VGTAW system is shown in Figure 5.



The system modifications allowed for the evaluation of the VGTAW process. The system pumping capacity, gas flow regulation into the chamber and electrode geometry are critical to the process. The full extent of their influence will be studied during Phase II of this program.

The hardware and software modifications have been tested during Phase I of this program. However, additional system modifications were identified during Phase I, (i.e., improvements to the gas regulation system) and will be addressed in Phase II of this program. This effort has defined the guidelines that allow an ionizing arc to be initiated and maintained in a vacuum environment.

#### **Task 12000. Materials Selection**

The objective of this task was to select "difficult-to-weld" materials for VGTAW experiments. Material candidates for weld studies were based on their difficulty-to-weld using conventional gas tungsten arc processes along with their applicability to NASA's mission, for example, the Space Shuttle Main Engine (SSME) and Space Shuttle Super Light Weight External Tank. The selection process considered welding problems that could be attributed to atmospheric influence and joining process characteristics. On the basis of these criteria the following materials were selected for evaluation:

- NARloy-Z
- Incoloy 903 Overlays
- Inconel 718 Casting
- Aluminum-Lithium

#### **Task 13000. VGTAW Experiments and Downselection**

The objective of this task was to conduct the VGTAW parameter development for the selected materials and select the most promising candidates. Critical parameters, such as, power, vacuum levels, gun-to-work distance, etc. were studied. Initial weld parameter selection was based on Rocketdyne's experience with conventional GTAW.

Evaluation of the welded specimens included metallography and microhardness measurements. Metallographic specimens were prepared from each weld sample at several locations and analyzed for defects and other anomalies.

#### **Experimental Procedure**

The VGTAW process requires a system that allows precise regulation of gas flow through the hollow electrode. The optimum gas flow rate is 1-100 ccm. The VGTAW process is made possible by controlling the environment in the arc region, between the tip of the hollow electrode and the workpiece. The introduction of the gas or mixture of gases into this region during arc initiation

and arc run is critical to the process. The vacuum level prior to introduction of the gas is  $3 \times 10^{-3}$  torr. This requirement is system specific due to the pumping capacity and chamber size. The gas flow required during arc initiation is 75 - 100 ccm. During this period, the pumping system must maintain a vacuum level of  $9 \times 10^{-2}$  torr. Once the arc is initiated, the gas flow is reduced to 10 - 20 ccm. These gas flow rates vary per type of material and desired weld bead geometry.

### NARloy-Z

NARloy-Z was selected because it is considered extremely difficult to weld repair using the standard GTAW and Variable Polarity Plasma Arc Welding processes. The ability to weld repair NARloy-Z material may allow extended use of the SSME Main Combustion Chambers (MCC).

Inert gas and vacuum GTA welds were made on 0.100 in. NARloy-Z plate in the as-rolled condition. The NARloy-Z inert gas- and vacuum-produced weld samples were fabricated and metallurgically evaluated. After the first sample set was evaluated, two more inert gas GTA welds were fabricated to duplicate the shallow and full penetration welds produced using VGTAW. Table 1 shows the weld parameters used for each condition.

Table 1. NARloy-Z Vacuum and Conventional GTA Weld Parameters

Condition	Vacuum Level	Ar Gas Flow	Amps	Travel Speed	Penetration
Vacuum	2 millitorr	10 ccm	45	8 in./min.	Shallow
Vacuum	2 millitorr	10 ccm	75	8 in./min.	Full
Atmosphere	1 atm	35 cfh	150	3 in./min.	Shallow
Atmosphere	1 atm	40 cfh	150	1 in./min.	Full

These welds were cross sectioned and Knoop hardness measurements were taken as a function of position across the welds. The measurements are plotted in Figure 6. In both cases, shallow and full penetration, the hardness of both types of welds are very similar. As would be expected, the hardness drops, from that found in the fine grained base metal, across the heat affected zone and then increases in the weld due to the fast cooling rates.

Using 75 amps, a weld was produced under a vacuum environment which had a bead width of 0.096 in., a bead depth of 0.028 in., and a weld bead area of 0.0027 in<sup>2</sup>. The weld bead geometry resembled a conventional, inert gas tungsten arc weld. The conventional GTA (150 amps, 35 cfh) weld produced had a bead width of 0.0415 in., a bead depth of 0.0066 in., and a weld bead area of approximately 0.00027 in<sup>2</sup>. The vacuum weld bead size is ten times that of the inert gas weld. This increase in melt area of the vacuum weld occurred using lower power input (75 amps) and faster travel speed (8 in./min), as compared to 150 amps, and 3 in./min. in the non-vacuum, inert gas weld.

It is believed that the increase in energy efficiency at the work piece is due to the constricted arc geometry, lack of contaminants present and lack of convective cooling of the material. This arc geometry change and its effects on the weld bead geometry will be studied further during this program.

The conventional GTAW was found to have a larger heat affected zone, indicated by recrystallization of the fine-grained, rolled NARloy-Z. This was likely due to the higher heat input of the conventional GTAW. The affect of heat input is very evident by comparing the shallow penetration conventional GTA and vacuum GTA welds in Figures 7 and 8, respectively. The material below the conventional GTA weld is recrystallized, while that below the vacuum GTA weld exhibits very little recrystallization.

Based on visual observations, the VGTAW process has better wetting of the weld pool material to the parent material. This could be attributed to the absence of the atmospheric contaminants present in a conventional GTAW. The apparent increase in fluidity using the VGTAW process can be affected by weldment surface cleaning prior to placement in the vacuum chamber, filler wire surface preparation and vacuum level during processing. Based on these results and the benefit to the SSME, this material will be further studied in Phase II.

#### Incoloy 903 Overlays

Incoloy 903 weld overlay was selected based on SSME fabrication usage. It is used throughtout the SSME as a protective barrier to prevent hydrogen embrittlement in Inconel 718. Incoloy 903 is overlaid on Inconel 718 using GTAW which typically requires several weld passes to achieve a sufficient thickness for a hydrogen barrier. After the Incoloy 903 has been deposited, it is machined to the desired geometry and dye penetrant inspected. The inspection may reveal the presence of microfissures.

The initial Incoloy 903 weld overlay samples were processed using as-received Inconel 718 plate prior to completing all of the vacuum chamber modifications. The welding parameters used to apply the Incoloy 903 are listed in Table 2.

Table 2. Incoloy 903 Weld Overlay Parameters

Gas Flow	Current	Wire Feed	Travel Speed
30 ccm	60 amps	25 ipm, 0.045" dia.	10 ipm

In spite of the less than optimum conditions, no microfissures were observed in the Incoloy 903 weld overlays after penetrant inspection (See Figure 9). On this

basis, Incoloy 903 overlay material will be investigated in Phase II, Task 21000, Materials Characterization.

The weld samples processed during Task 21000 will use solution annealed Inconel 718 base plates so the data will be compatible with work being performed currently under the SSME contract.

### Cast Inconel 718

Conventional inert gas tungsten arc welding is the standard process used to weld Inconel 718 cast material. The problems associated with GTAW on this material are microcracks and porosity in the parent material. These problems are caused by thermal induced stresses and distortion due to the welding process.

Pieces of a coarse grain (grain size of approx. 1/16 - 1/8 in.) Inconel 718 casting were obtained to evaluate the performance of VGTAW to weld and repair these castings. This type of material was chosen, as previously stated, because it is considered to be hard to weld or unweldable and is a material used throughout the SSME and other aerospace systems.

Weld samples were prepared with VGTAW and conventional, inert-gas welding. The parameter variables for both processes were duplicated with the exception of the atmospheric pressure and gas flows. VGTAW welds were processed at a vacuum level of 3 microns and an argon gas flow rate of 7 ccm, while the conventional GTA welds were processed at 1 atmosphere with an argon gas flow rate of 40 cubic feet per hour (67,240 ccm). The VGTAW sample (Figure 10) as compared to the standard GTAW (Figure 11) shows an increase in weld bead width and reduced penetration. This geometry can be modified by increasing or decreasing the gas flow rate. The samples did not show a significant improvement with the limited number of samples. Therefore, this material was not selected for Phase II evaluation.

### **Task 13100. High-Frequency, Pulsed-Current and Air-Coupled Acoustic GTAW**

The objective of this task was to investigate the effects of welding Al-Li both under vacuum and in an inert environment. In addition, the effect of high-frequency, pulsed-current and air-coupled acoustic GTAW was to be studied.

The Al-Li material was selected for evaluation based on weldability problems experienced during the Space Shuttle's Super Light Weight External Tank Program. In this program the Variable Polarity Plasma Arc Welding (VPPAW) is employed to produce the initial weld. Then, weld repair is performed using the GTAW process. During the weld repair evaluation, the material properties of the weld material and adjacent parent material were reduced to an unacceptable level. This condition is attributed to a concentration of small, equiaxed grains

present along the fusion zone of the weld, and the repeated thermal cycling of the heat affected zone causes most of the reduction in properties. (This is part of an on-going investigation by the NASA-MSFC to learn more about the weld reparability of Al-Li).

The equiaxed grain structure concentrated at the edge of the weld pool (Figure 12) has more surface area than the larger columnar grain structure that comprises the rest of the weld cross section. This allows a higher concentration of the lower melting temperature materials (i.e., lithium) to accumulate at the grain boundaries. The increased presence of lithium material reduces the tensile strength in this region. The focus of this effort was to reduce or eliminate the equiaxed grain structure in this region.

The approach to minimize the presence of the equiaxed grain used an in-process agitation of the weld pool. It was speculated that this in-process weld pool agitation would reduce or eliminate the formation of the equiaxed grain along the fusion zone and cause a more columnar grain structure across the entire weld and improve material properties. The proposed methods for in-process agitation of the weld pool were air coupled acoustic and high frequency pulsed current. Metallographic examination was used to study differences between welds produced conventionally and those produced on this program.

The set-up used for the out-of-vacuum Al-Li welds, (Figure 13) was designed and fabricated. Samples were prepared using the standard autogenous GTAW process. The samples consisted of flat plates approximately 4 in. x 12 in. x 0.250 in..

The initial linear welds on Al-Li were processed using the pulsed current method. The parameters used are listed in Table 3.

Table 3. Al-Li GTA Weld Parameters Using the Pulsed Current Method

<u>Pulse frequency</u>	<u>High Current</u>	<u>Low Current</u>	<u>Speed</u>
0 pps	80	80	8 ipm
10 pps	80	20	8 ipm
25 pps	80	20	8 ipm
50 pps	80	20	8 ipm
75 pps	80	20	8 ipm
99 pps	80	20	8 ipm

The evaluation of the pulsed current welds showed that the fine grains were reduced in the fusion zone at frequencies of 10, 50 and 99 Hz, but not eliminated. In addition, several resolidification zones were found in the fusion line of these samples. These were attributed to the "footprint" of the high current pulse of the weld cycle, which resulted in a series of transition zones along the weld. The pulsed current effect is not found in a continuous current conventional GTAW. This caused several very fine layers of equiaxed grains at each of these zones, which would likely be detrimental to the tensile strength.

The evaluation of the air coupled acoustic vibration weld samples were performed next. This series of weld samples required the design of a system that was able to transmit an acoustic signal capable of vibrating the weld sample and holding device, (Figure 13), through a large range of frequencies, 10 Hz - 1 MHz. The experimental parameters are listed in Table 4. DC straight polarity was employed using helium as an arc gas.

Table 4. Al-Li GTA Weld Parameters Using Air Coupled Acoustics

<u>Acoustic Frequency. Hz</u>	<u>Current. amps</u>	<u>Travel Speed. in/min.</u>
10	76	7.5
30	100	7.5
40	100	7.5
100	100	7.5
203	75	7.5
500	75	7.5
1000	75	7.5

The metallographic analysis of the air coupled acoustic GTA weld samples showed differences at the 100 and 203 Hz frequencies. Very few equiaxed grains were detected at the fusion zone of these two samples indicating that there could be certain frequency ranges where equiaxed grains may be eliminated. Photomicrographs of the 100 and 203 Hz frequencies are shown in Figures 14 and 15, respectively.

The in-process weld pool agitation of the Al-Li material did reduce the presence of the equiaxed grain structure, but it did not eliminate the equiaxed grains at the fusion zone. These samples did demonstrate the ability to modify the post-weld condition of the material. When comparing these weld samples to the conventional GTAW, the differences are apparent. The potential benefits of these differences have not been established by mechanical testing of the weld samples.

When comparing the in-process weld pool agitation samples, discussed above, to the VGTAW samples, the VGTAW samples have a higher population of equiaxed grains at the fusion line of the weld. This zone of equiaxed grain is distributed along the entire perimeter of the weld. Photomicrographs of the VGTAW Al-Li are shown in Figures 16 and 17. It can be seen that the fusion zone is perpendicular to the plate surface. A minimal heat affected zone was also observed. The Al-Li samples processed using the VGTAW process did not reduce the presence of equiaxed grain structure.

The VGTAW bead geometry has an increase in penetration depth relative to the weld bead width. These welds were produced using 20 inches per minute of travel speed, 75 amperes, 16 volts and 0.2 inch thick sample. The weld bead width is 0.2 inch on the surface and the depth is 0.21 inch; this includes the weld bead drop through.

Knoop microhardness tests were performed on the samples produced using the three GTAW process variations. Hardness measurements, shown in Figure 18, were made across the weld bead to determine hardness from the parent material through the heat affected zone, fusion zone and weld. The hardness of the standard GTAW and the standard GTAW with acoustics are similar in that they seem to drop in the heat affected zone and reaches a minimum at the weld centerline. The VGTAW sample, however, exhibits fairly consistent hardness across the weld bead.

The differences between the VGTAW and conventional GTAW have been evaluated based on available data from the current repair investigation at MSFC. Because of the increase in the equiaxed grain population in the VGTAW samples, Al-Li was not chosen for Phase II evaluation.

### **Materials Downselection**

The evaluation of the welded materials verified the ability of VGTAW to produce improvements over conventional GTA welds. The evolution of the VGTAW process is ongoing and the downselection was based on weld samples processed using the current configuration. The downselection to two of these materials, Incoloy 903 overlay and NARloy-Z, was based on the results of the initial weld samples.

## **Conclusions And Recommendations**

The system modifications completed during Phase I have improved the VGTAW system and processing capability. The level of control over the vacuum, motion control and gas flow system in this unit allows sample repeatability and process evaluation. This system has demonstrated the ability to incorporate an electro-mechanical, multiple-axes positioning device into a vacuum/welding environment and operate for extended periods of time.

The initial material weld sample evaluation demonstrated the ability to process a variety of materials using the VGTAW process. This system demonstrated that the VGTAW process can change the post-weld condition of the materials tested. These changes will be the subject of Task 22000 in Phase II.

During the Phase I system modification, it became apparent that the gas flow and gas volume can cause dramatic changes in the welding arc geometry. Changes in arc geometry affect the welding power supply output and the weld bead geometry. During Phase II of this program, the gas management system will require further modifications. These modifications will improve control over the gas flow rate and mixing of gases used in this process.

Based on experience gained during Phase I, it is recommended that the system incorporate three more precision rotometers. The addition of these rotometers

will allow several types of gases to be regulated and ported to the hollow electrode. These rotometers need to be located at the manifold upstream from the digital mass flow meter. This improvement would also allow multiple gases to be introduced to the inlet port with a high level of repeatability.

One of the apparent differences between VGTAW and conventional GTAW is a more efficient energy transfer when using the VGTAW process. This was characterized best during the NARloy-Z weld comparison. The VGTAW weld cross section area was ten times that of the standard GTAW weld using the same welding parameters indicating that, to produce the same size weld bead, the heat input and associated thermal effects could be reduced.

The VGTAW process has a variety of potential advantages over conventional metal joining processes. These include elimination of atmospheric contaminants present during processing and increased weld bead depth of penetration with reduced heat input. These process characteristics are desirable in many metal joining applications and could improve the weldability of currently hard to weld materials.

The VGTAW process has changed the post weld condition of the materials evaluated as compared to conventional GTAW. Post weld changes consisted of improved wetting of the weld pool, reduction of heat induced defects, reduction of environmentally induced defects and increased the depth of penetration of the weld as compared to conventional GTAW.

The initial list of candidate VGTAW samples was screened down to two materials; Incoloy 903 overlays and NARloy-Z. The development of the VGTAW process is ongoing and the downselection was based on weld samples processed using the current configuration. The downselection to two of these materials was based on the results of the initial weld samples. VGTAW of these materials will be more fully characterized in Phase 2 of this program. Further, VGTAW of these materials on a representative piece of hardware will be performed and a manufacturing implementation plan will be developed.



# Vacuum Gas Tungsten Arc Welding Program Schedule

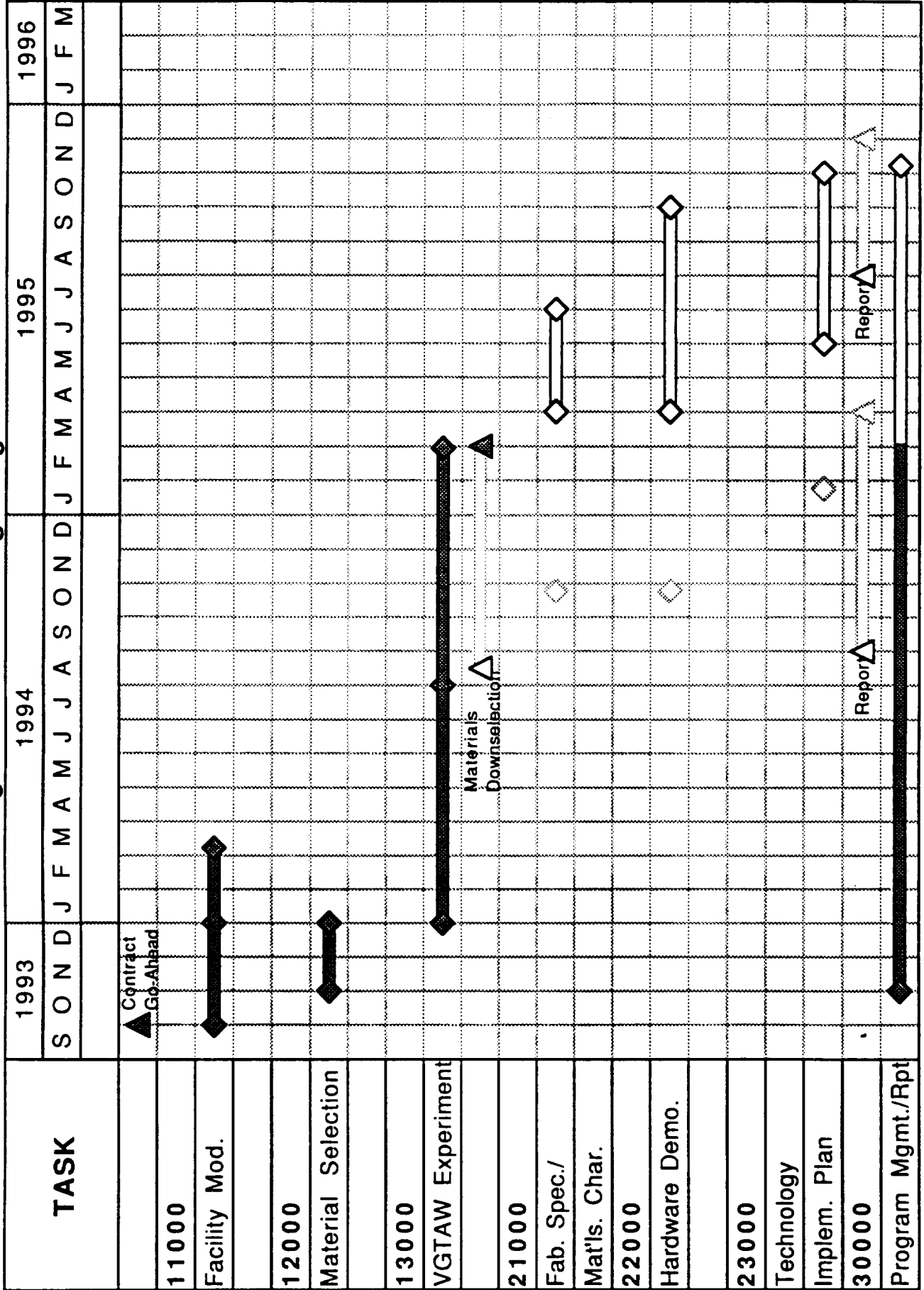

Figure 1

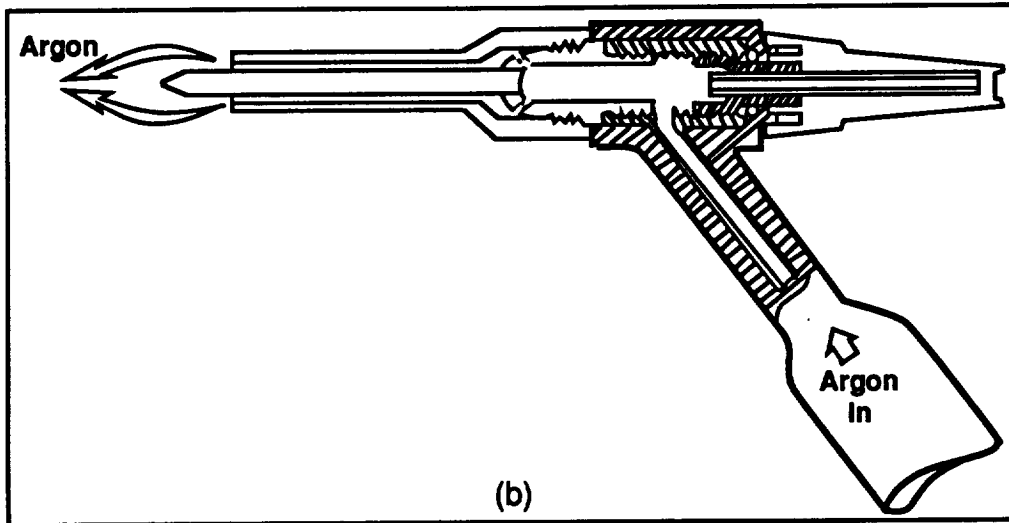
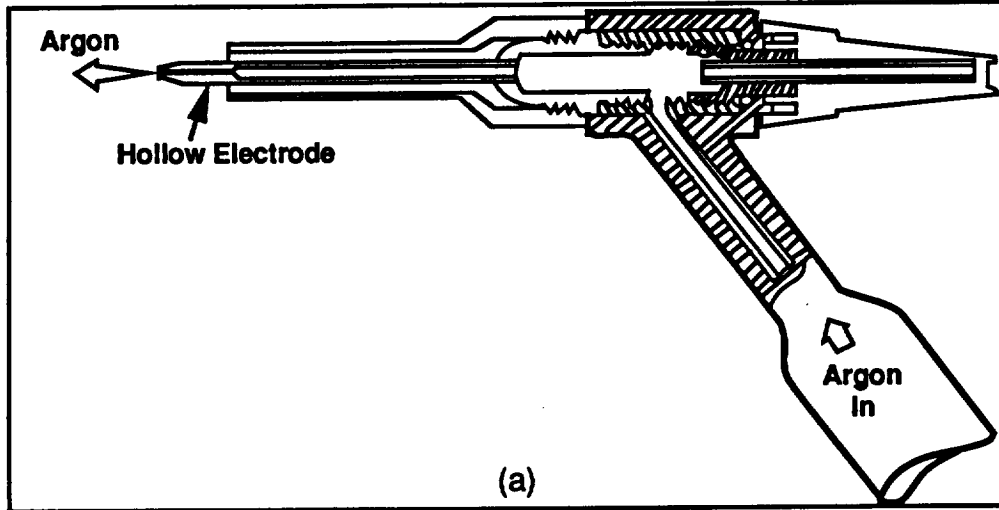

Figure 2. Conventional (a) and Vacuum (b) GTAW Torches

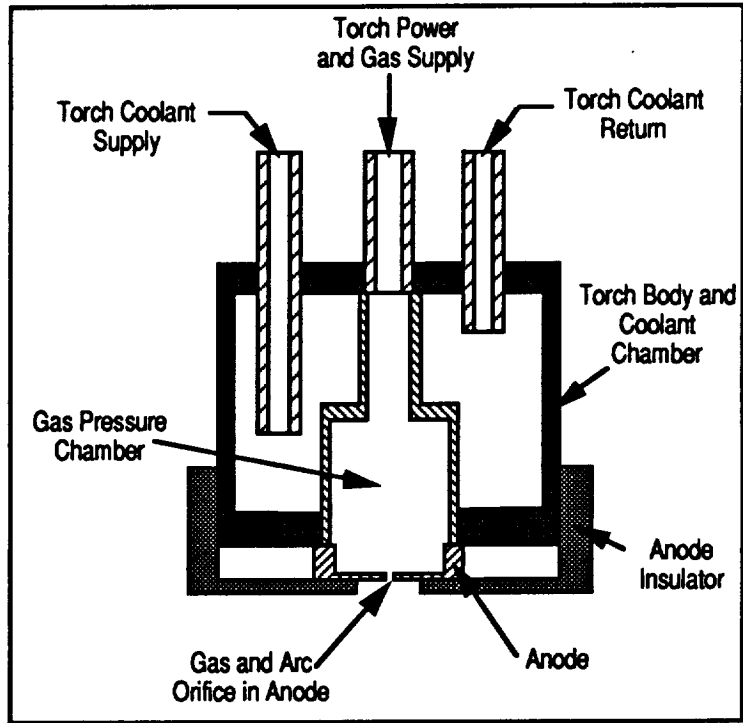

Figure 3. Improved Vacuum Gas Tungsten Arc Welding Torch

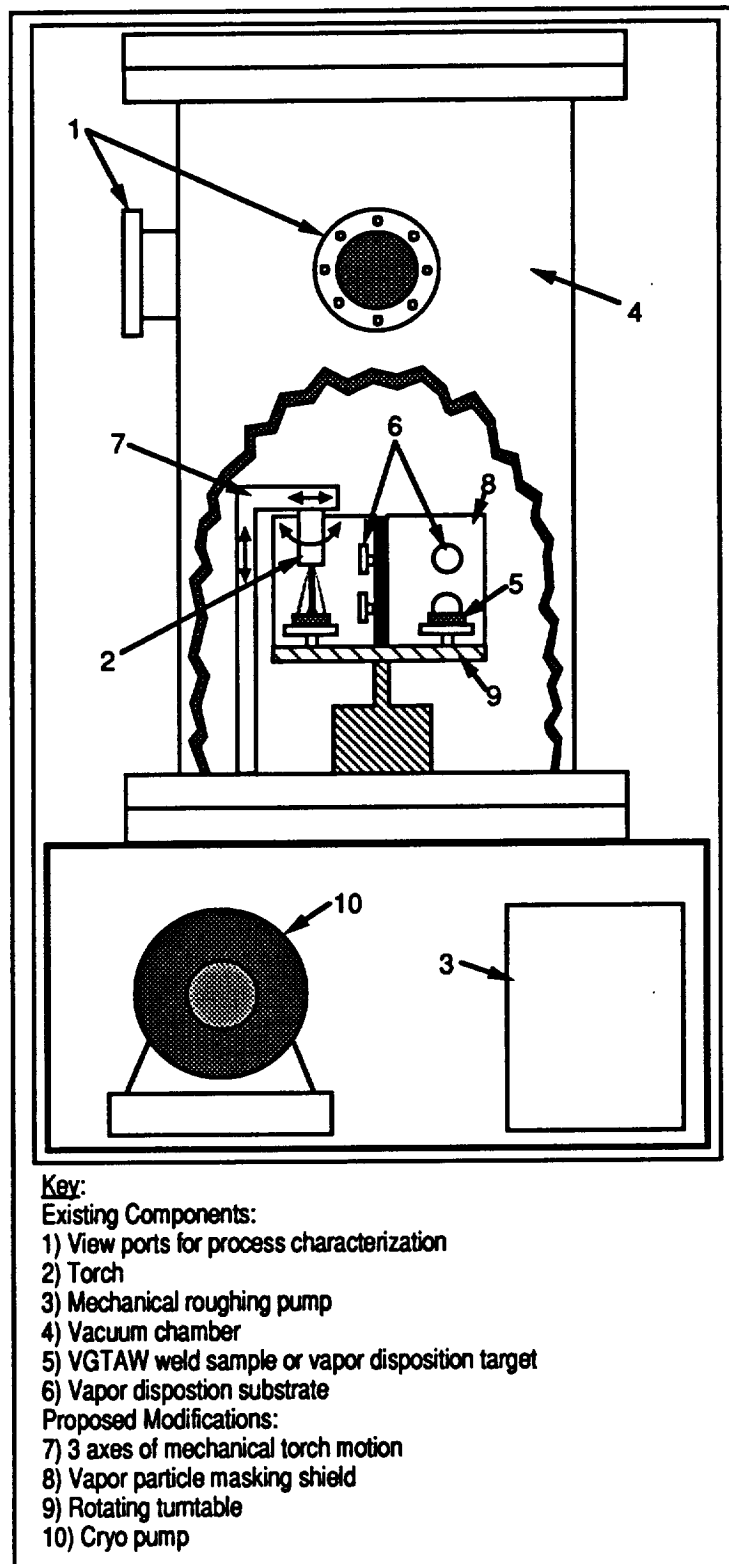

Figure 4. Schematic of Original VGTAW Used for Process Demonstration at NASA-MSFC

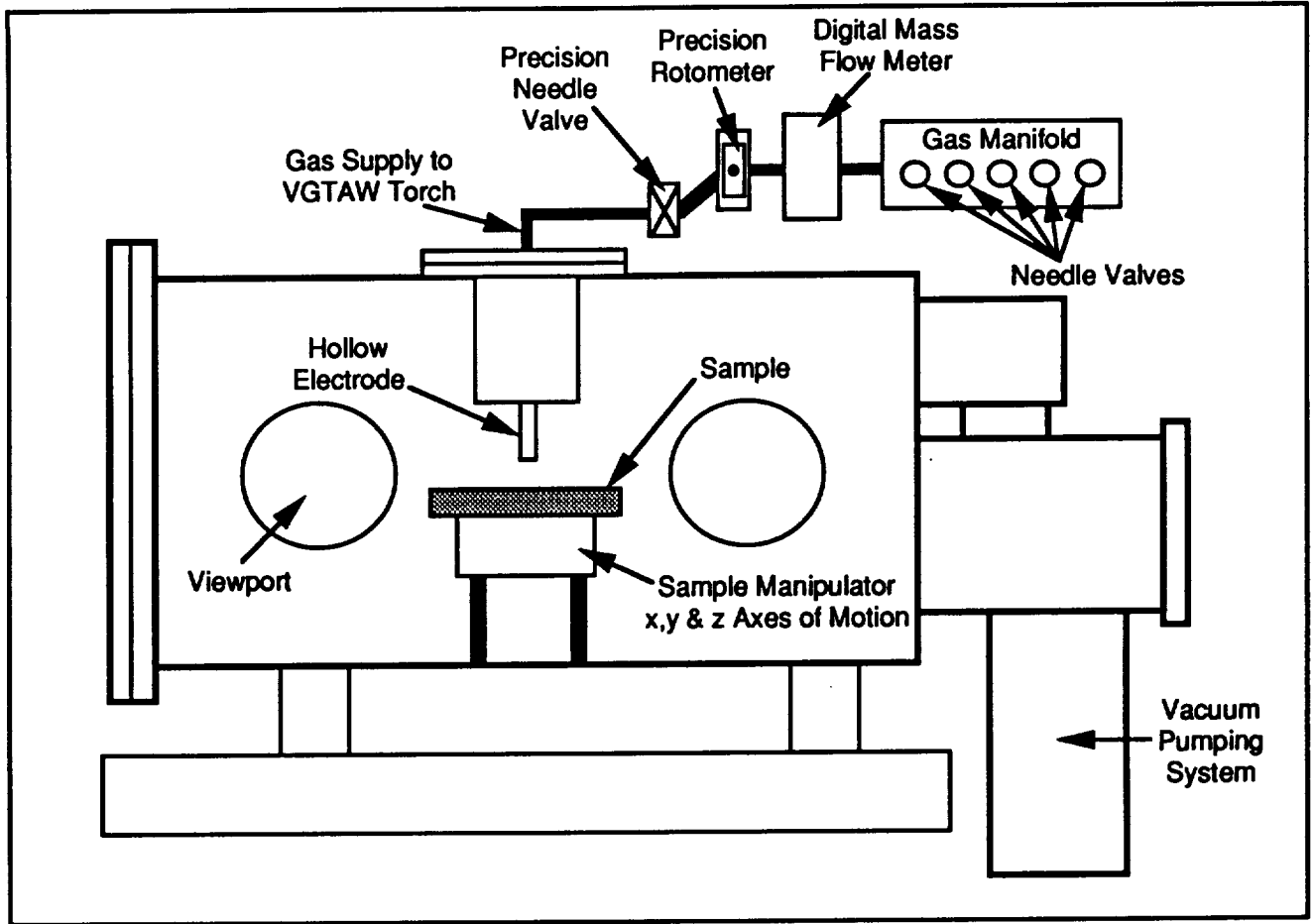

Figure 5. Schematic of the Modified VGTAW System

# Conventional GTA & Vacuum GTA Welds on NARloy-Z

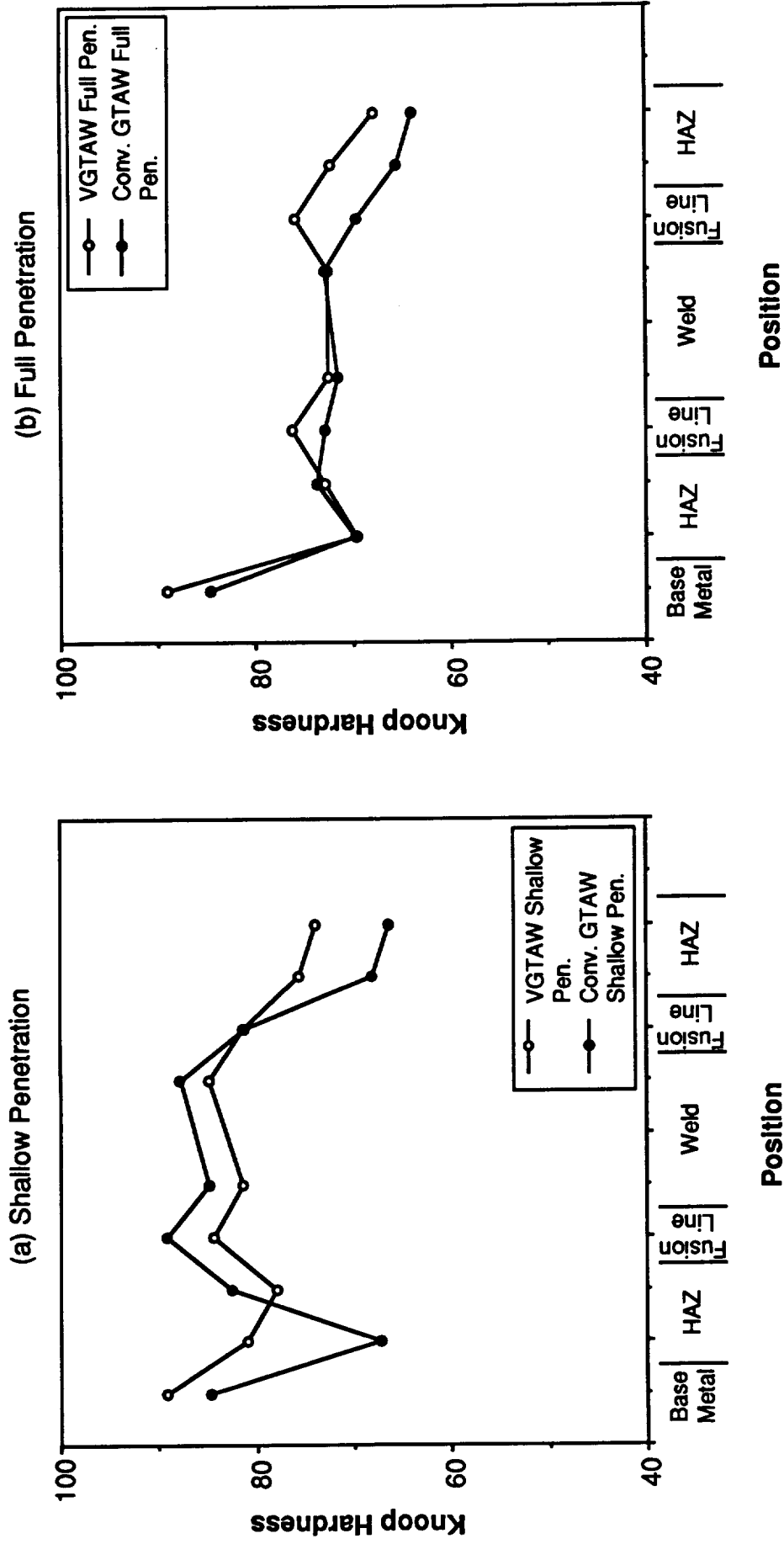
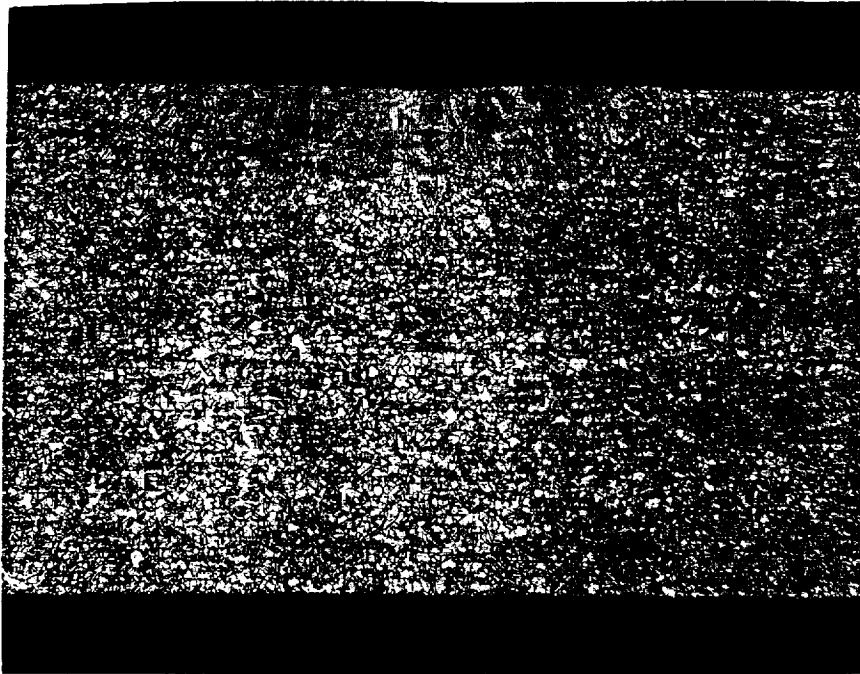
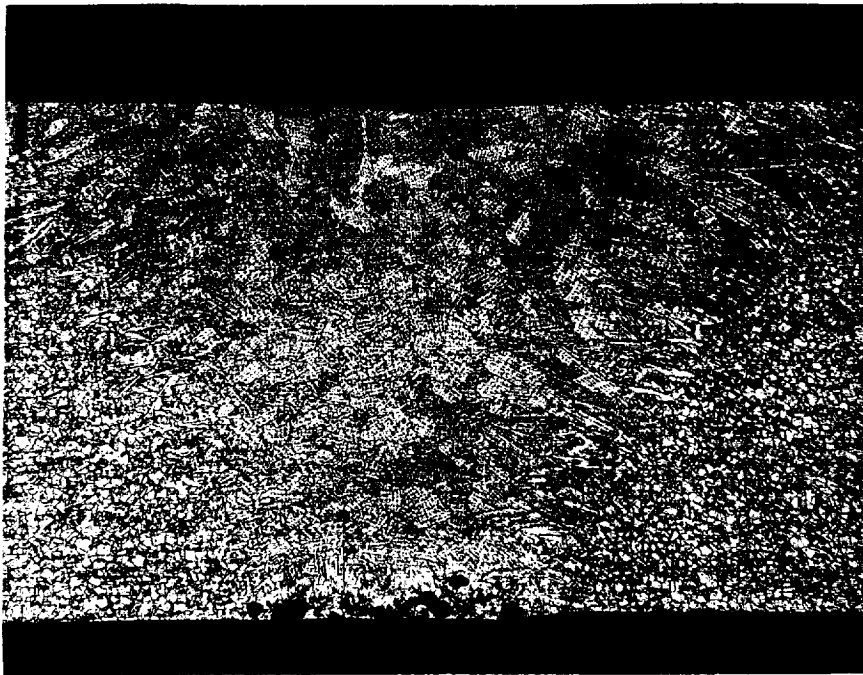

Figure 6. Knoop hardness measurements on (a) shallow and (b) full penetration conventional and vacuum GTA welds on NARloy-Z.



(a)



(b)

Figure 7. Photomicrographs of (a) shallow and (b) full penetration conventional GTA welds on NARloy-Z.

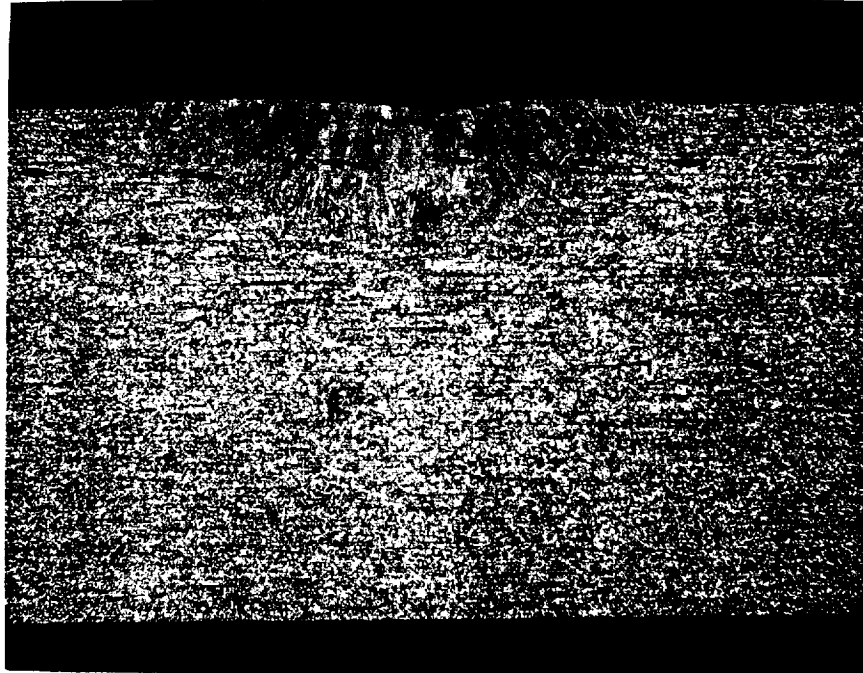

(a)

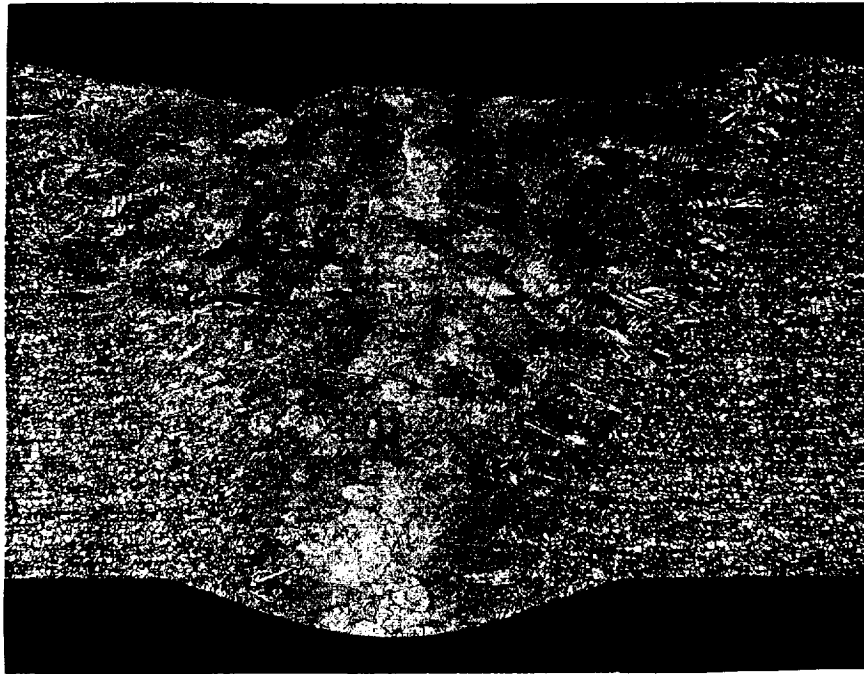

(b)

Figure 8. Photomicrographs of (a) shallow and (b) full penetration vacuum GTA welds on NARloy-Z.



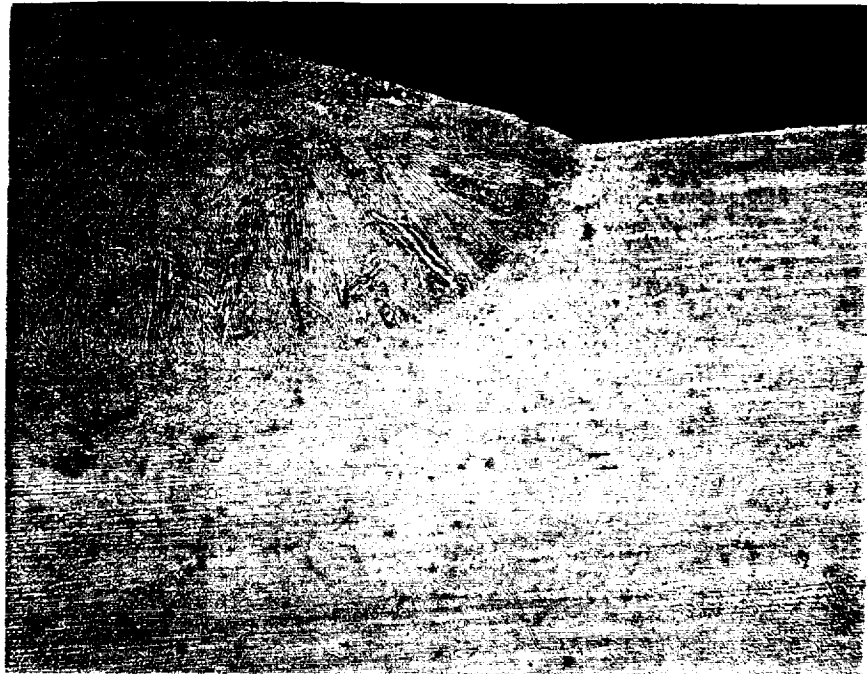

(a)

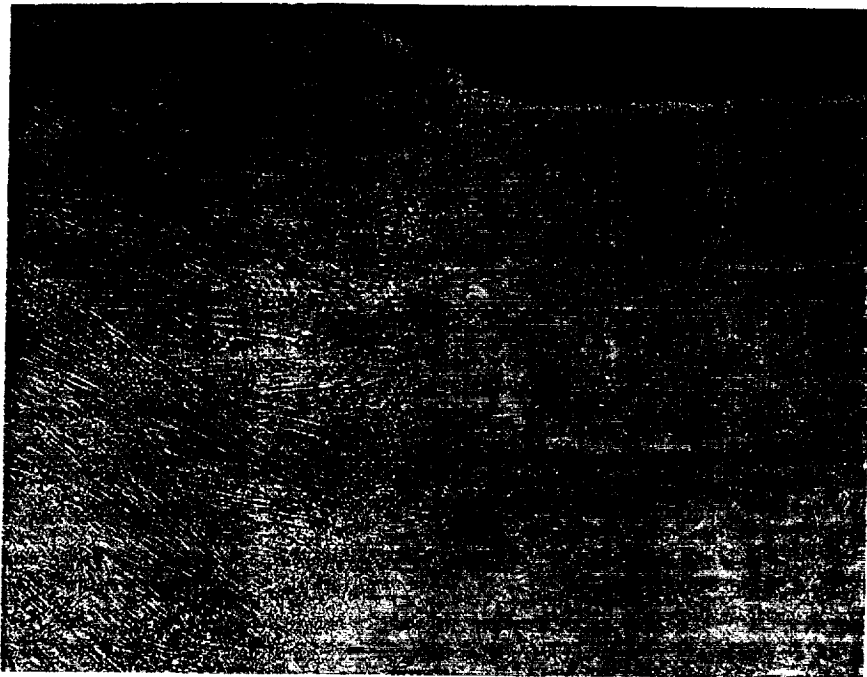

(b)

Figure 9. Photomicrographs of Incoloy 903 VGTAW Overlays on Inconel 718 at (a) 25x and (b) 100x.

## Microstructure of Vacuum Gas Tungsten Arc Welding for Cast Inconel 718 Weldability Test

Run # V-94-8-A

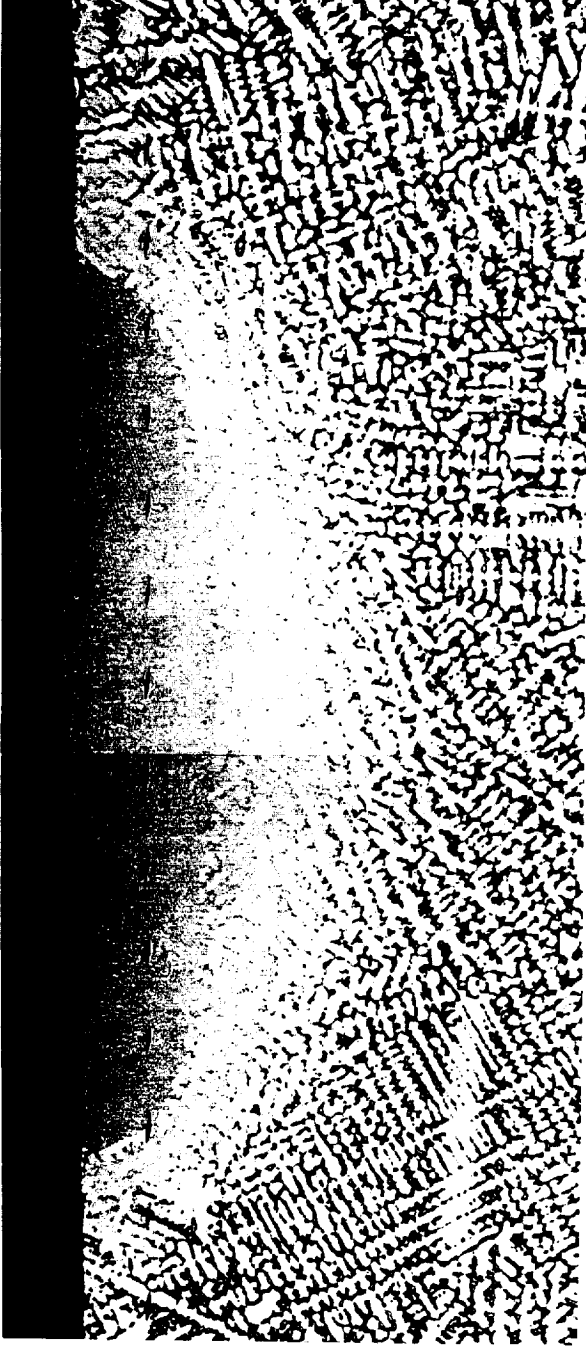

Etched 25X

- Fine Laves particle in the interdendritic regions at the weld
- Coarse Laves particle in the interdendritic regions at the base metal
- Large heat affected zone
- No distinct fusion zone
- Increased weld pool area as compared to conventional GTAW with same parameter
- The Laves phase became partially dissolved in the HAZ

# Macro & Microstructure of Gas Tungsten Arc Welding for Aluminum Lithium Weldability Test

Figure 12

Run # 94-9-Alli



No Acoustic Vibration with 5 start  
(No Wire)  
Etched (overall shot)

- DC Straight Polarity

Edge of the  
Fusion Zone

Heat-affected  
Zone

Base Metal  
Alli

Etched 50X

- Finer Columnar Grains
- Columnar Grains at the Edge of the Fusion Zone

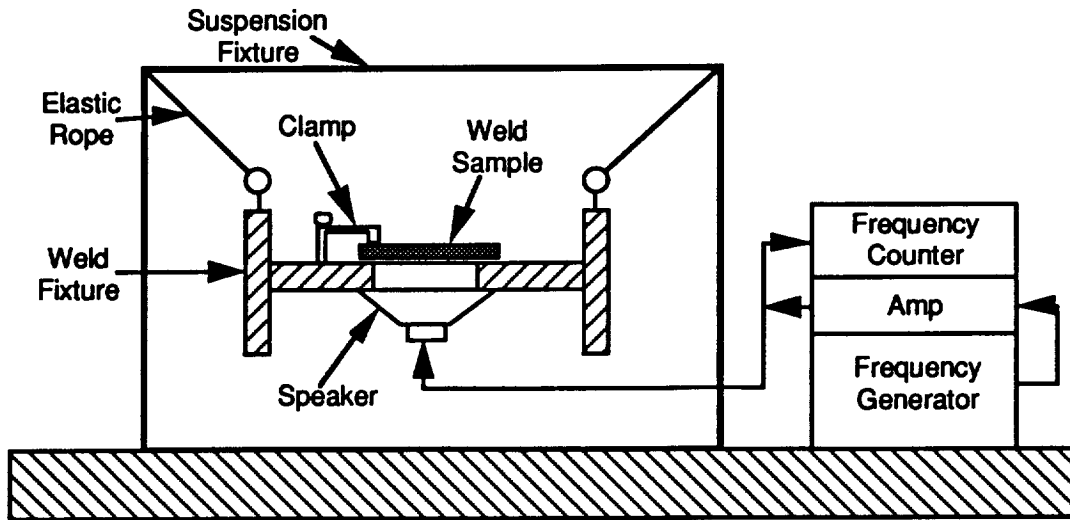

Figure 13. Schematic of Air Coupled Acoustic Experimental Weld Set-up

# Microstructure of Gas Tungsten Arc Welding for Aluminum Lithium Weldability Test

Run # A-94-25-A



Etched 25X

- Air Coupled Acoustic
- DC Straight Polarity
- Travel Speed - 7.5
- He Arc Gas



Etched 200X

- 100 HZ Frequency
- Current - 100
- Voltage - 12

# Microstructure of Gas Tungsten Arc Welding for Aluminum Lithium Weldability Test

Run # A-94-26-A

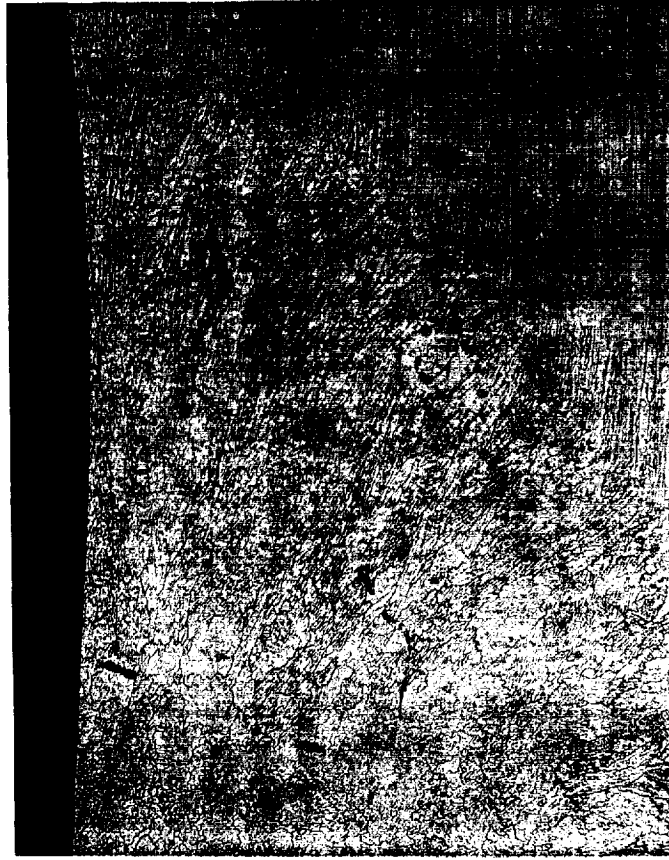

Etched 25X

- Air Coupled Acoustic
- DC Straight Polarity
- Travel Speed - 7.5
- He Arc Gas

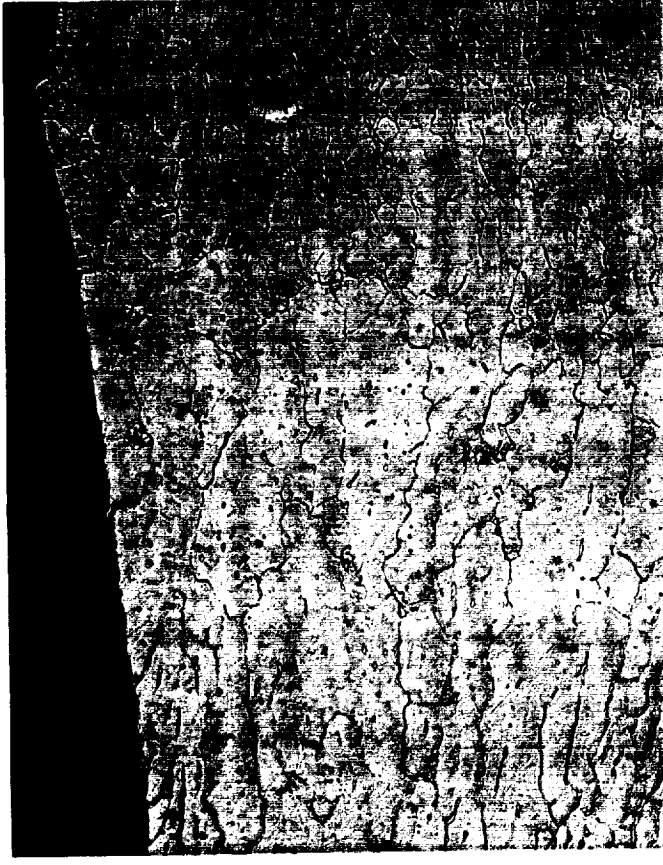

Etched 200X

- 203 HZ Frequency
- Current - 75
- Voltage - 12

# Microstructure of Vacuum Gas Tungsten Arc Welding for Aluminum Lithium Weldability Test

Figure 16

Run # 94-V-ALLi-1

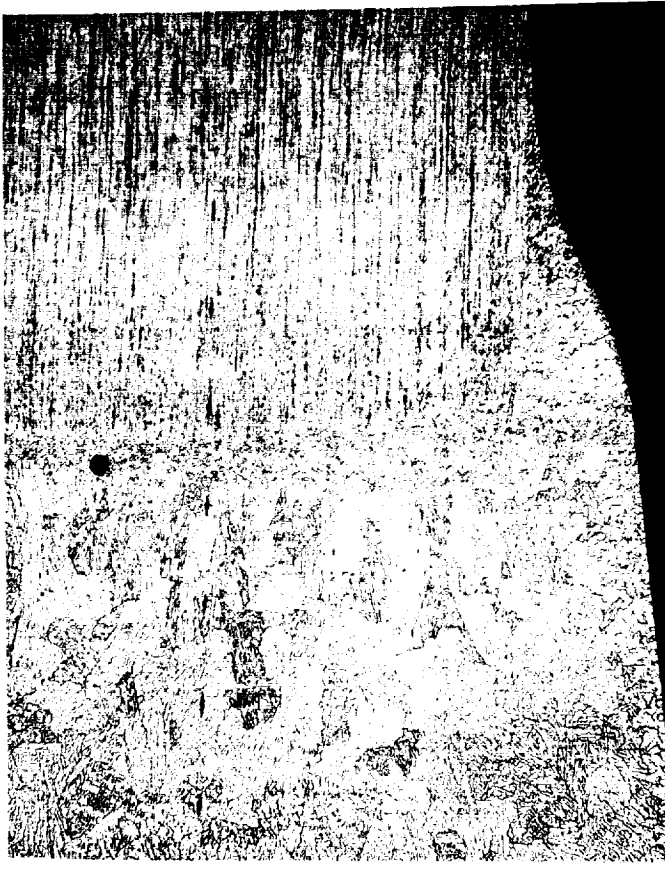

Vacuum GTA Weld (No Wire)  
Etched (overall shot)

- Full Penetration Weld
- DC Straight Polarity

↑ Edge of the Fusion Zone      ↑ Heat-affected Zone      ↑ Base Metal  
Etched      Etched      ALLi      25X

- Equiaxed Grains & Dendritic Structure
- Narrow HAZ
- Abrupt Change of Base Metal to Weld Bead

# Microstructure of Vacuum Gas Tungsten Arc Welding for Aluminum Lithium Weldability Test

Run # 94-V-ALLi-1

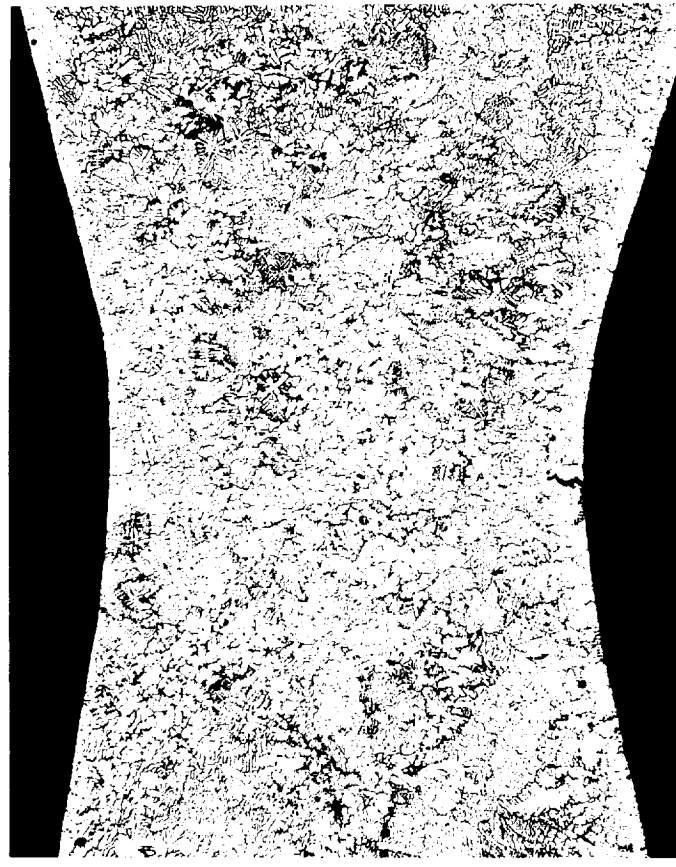

Etched 25X



Etched 50X

Vacuum GTA Weld (No Wire)

- Full Penetration Weld
- DC Straight Polarity
- Equiaxed Grains & Dendritic Structure
- Narrow HAZ



Figure 18

